



Università degli Studi di Trieste

Dipartimento di Ingegneria e Architettura

Laurea Magistrale: Ingegneria Civile

Corso di INFRASTRUTTURE AEROPORTUALI

Lezione 05: Geometria del lato aria

Roberto Roberti

Tel.: 040/558.3588

E-mail: roberto.roberti@dia.units.it

Anno accademico 2016/2017



Argomenti

Dati di riferimento di un aerodromo

Manovre di decollo e atterraggio e Lunghezza pista

Caratteristiche geometriche delle runway (planimetriche e altimetriche)

Distanze di separazione nella circolazione a terra

Caratteristiche geometriche delle uscite dalle runway e delle holding bay

Caratteristiche geometriche delle taxiway e manovre di taxing

Esercizio sulle piste di volo

Dati di riferimento di un aerodromo

Punto di riferimento

Altitudine aerodromo e piste

Temperatura di riferimento

Dimensioni e informazioni aerodromo

Distanze dichiarate

Le manovre di decollo (1)

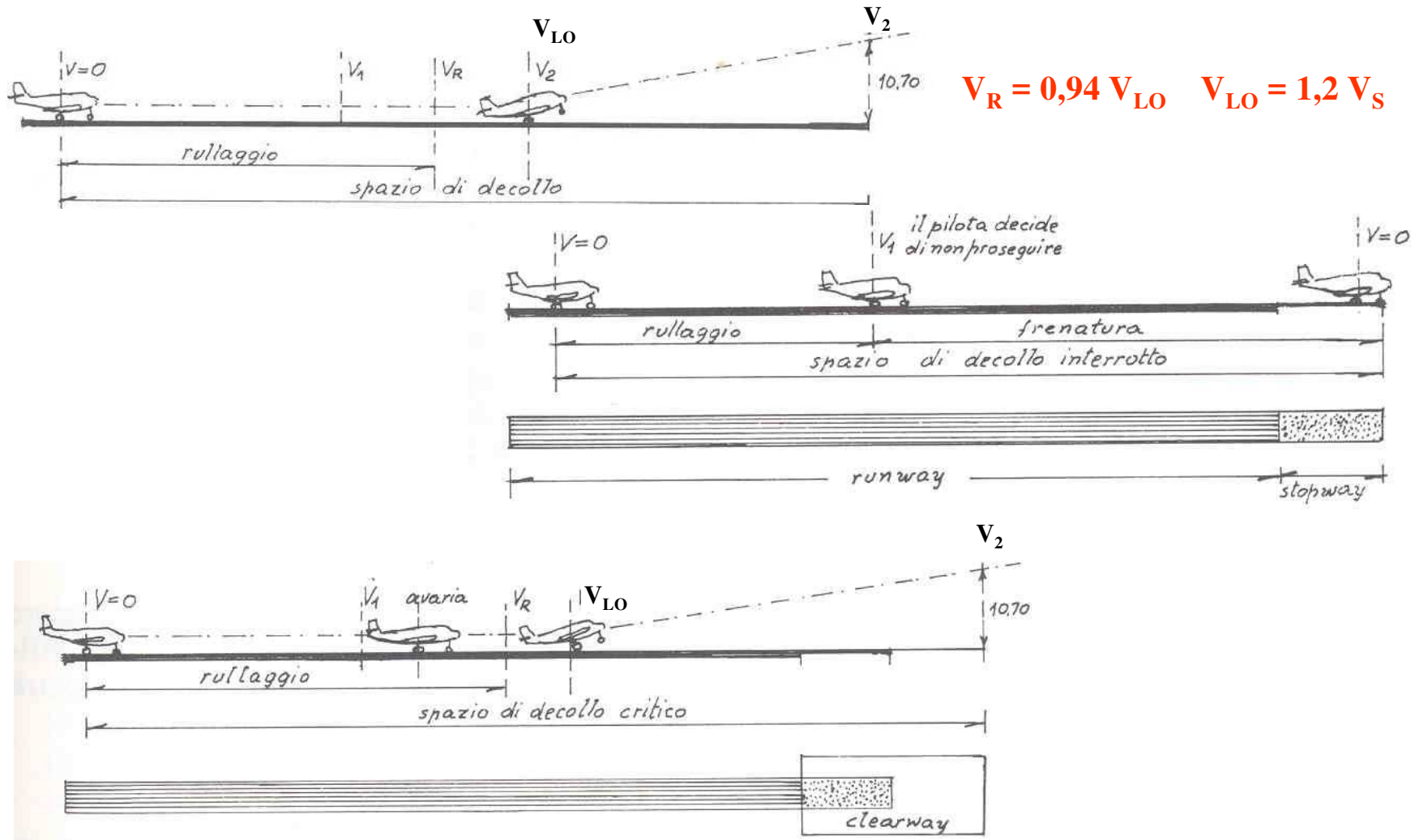

Le manovre di decollo (2)



Figura 10. 6: Legge del moto dell'aeromobile in fase di decollo in condizioni normali (a) ed in caso di avaria ad un motore (b).

La salita di decollo



Le manovre di avvicinamento (1)

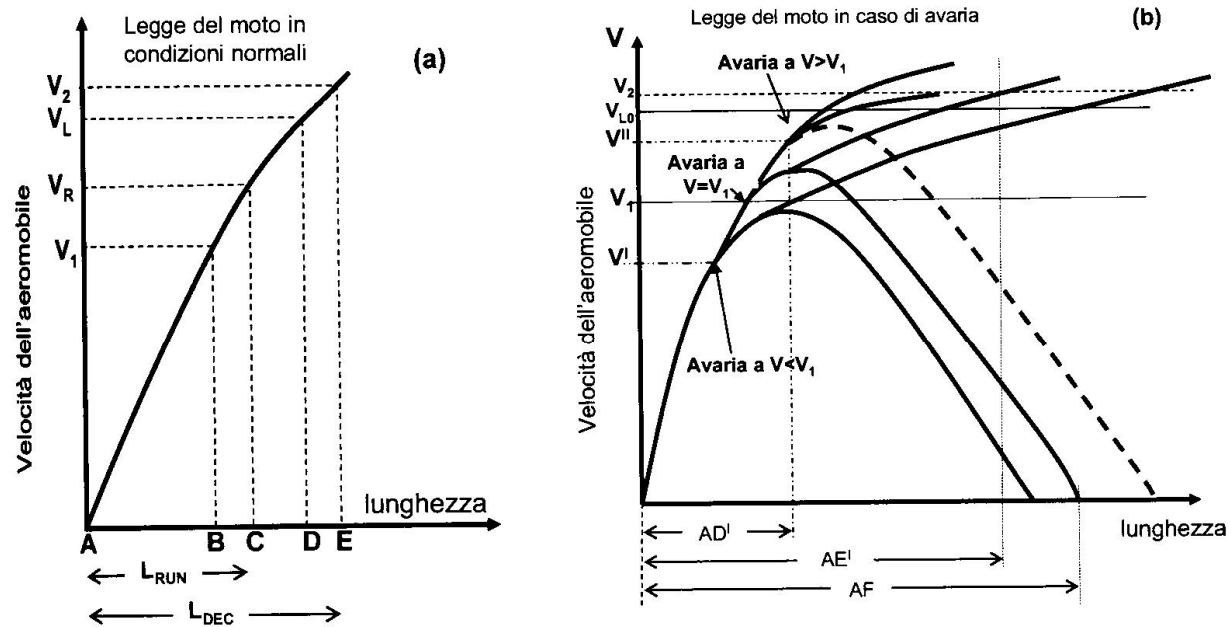
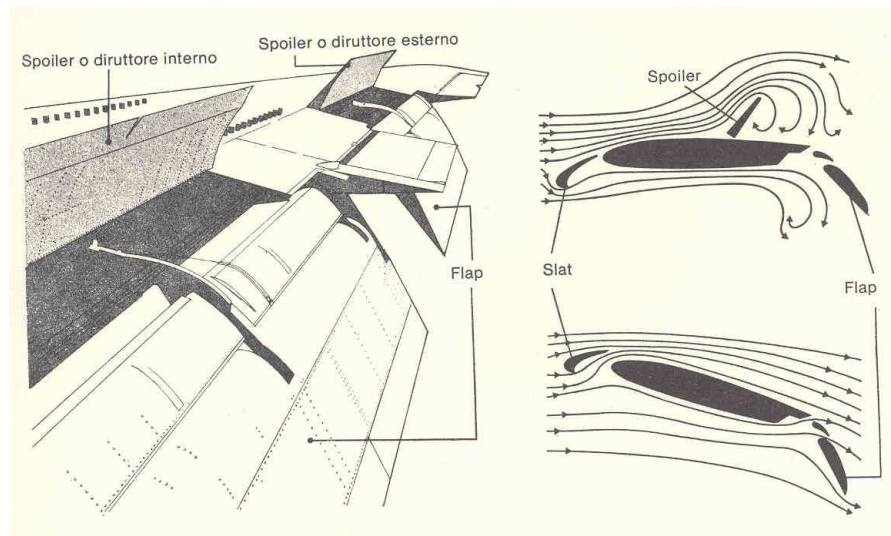
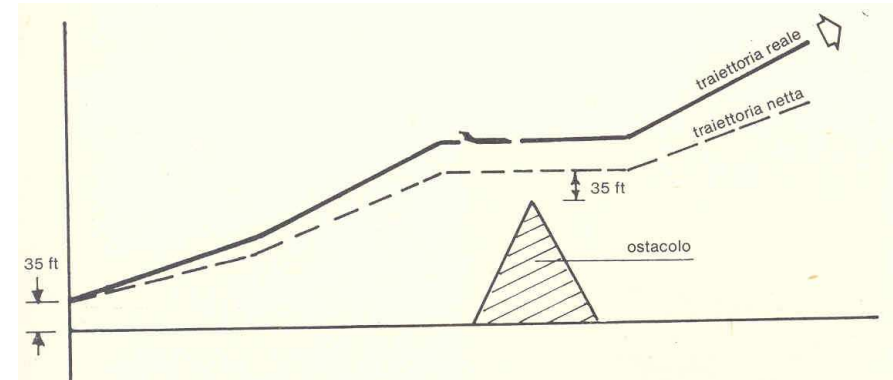
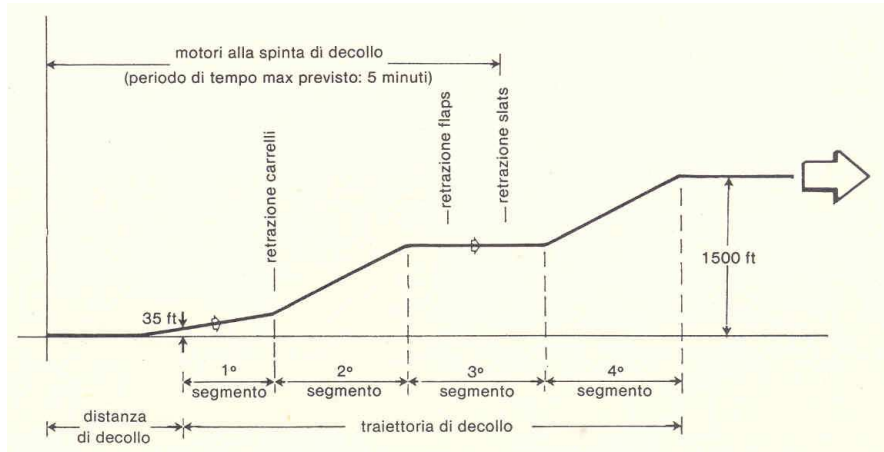
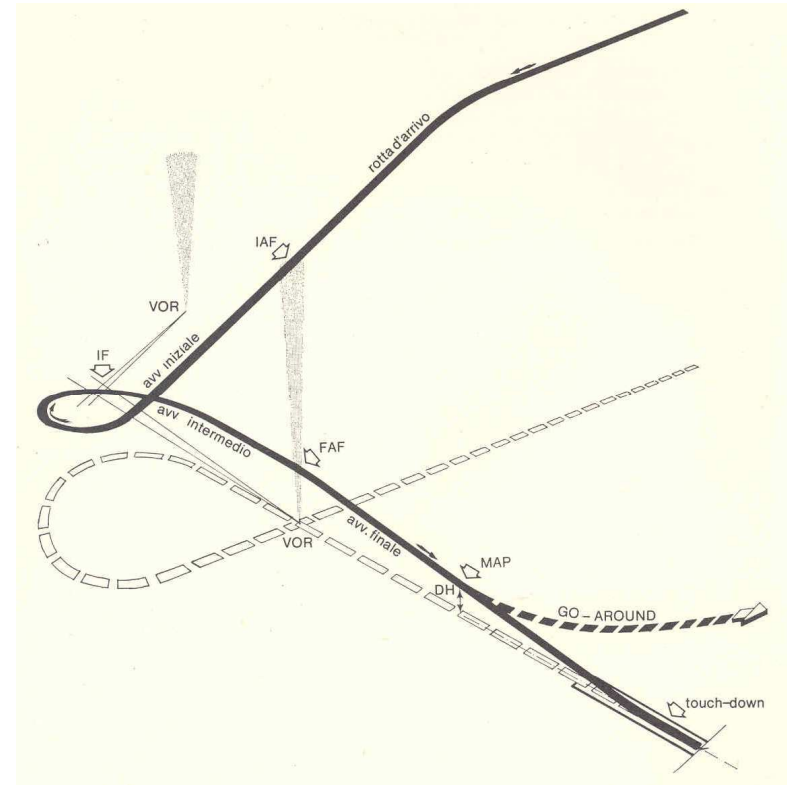
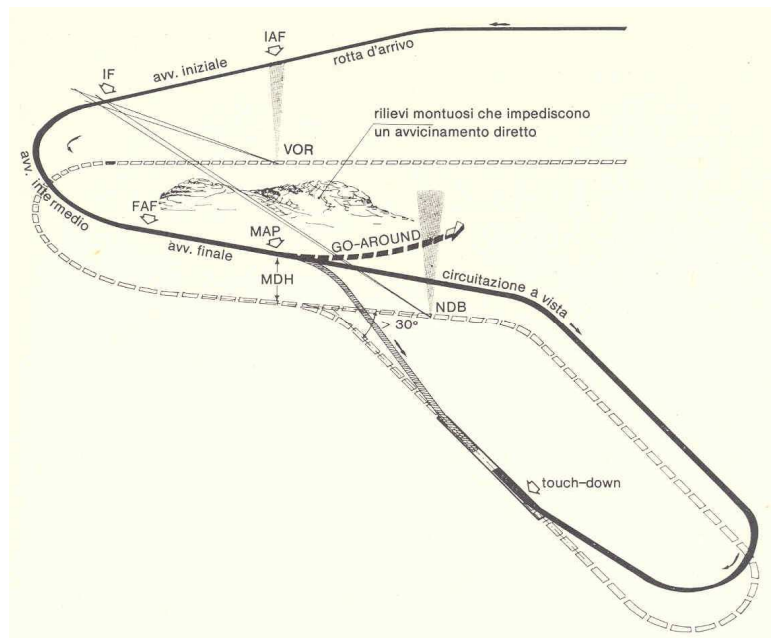
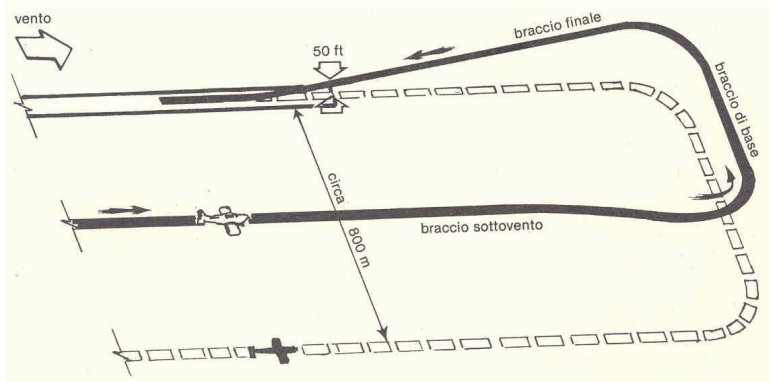

Le manovre di avvicinamento (2)

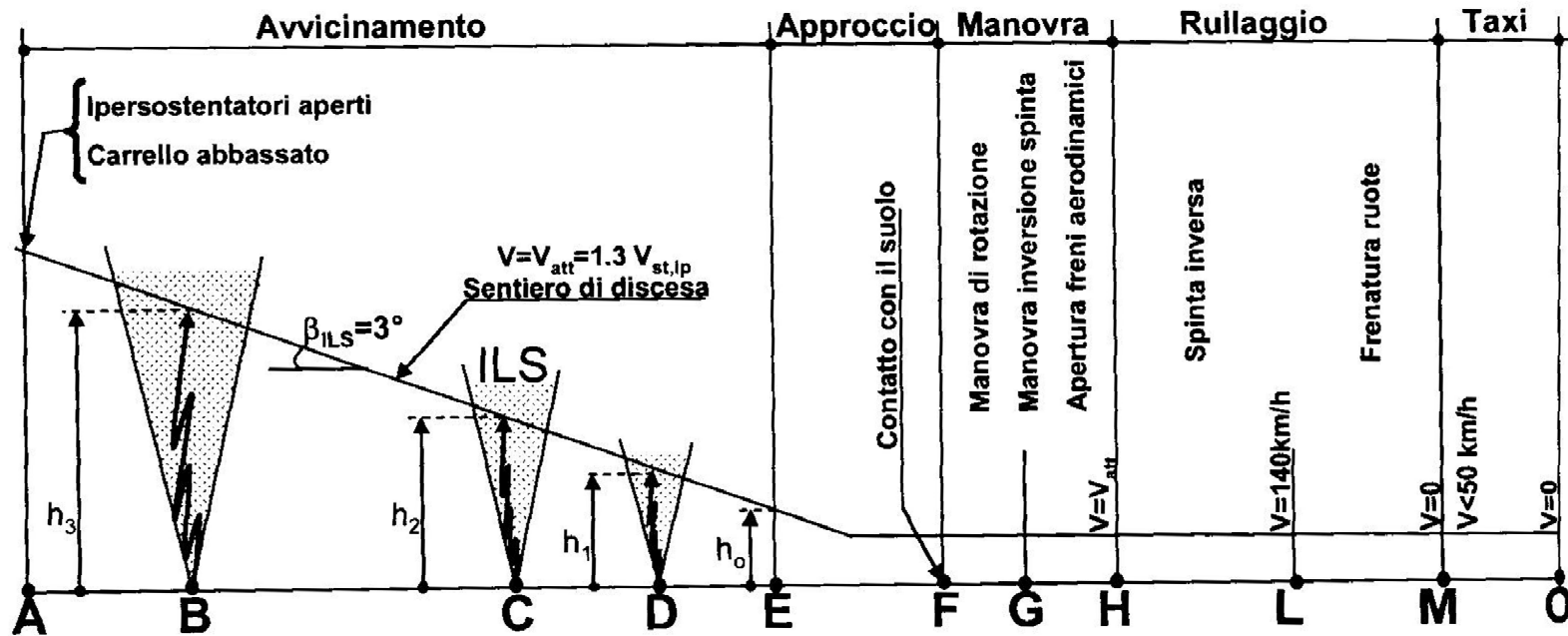

Le manovre di atterraggio

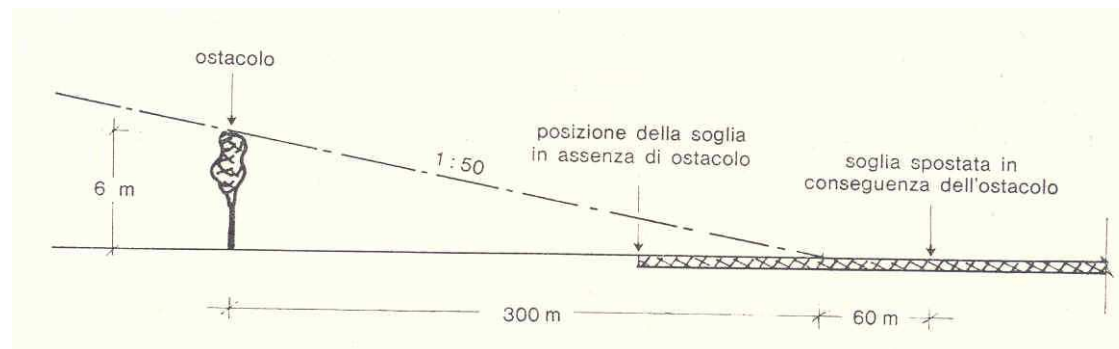
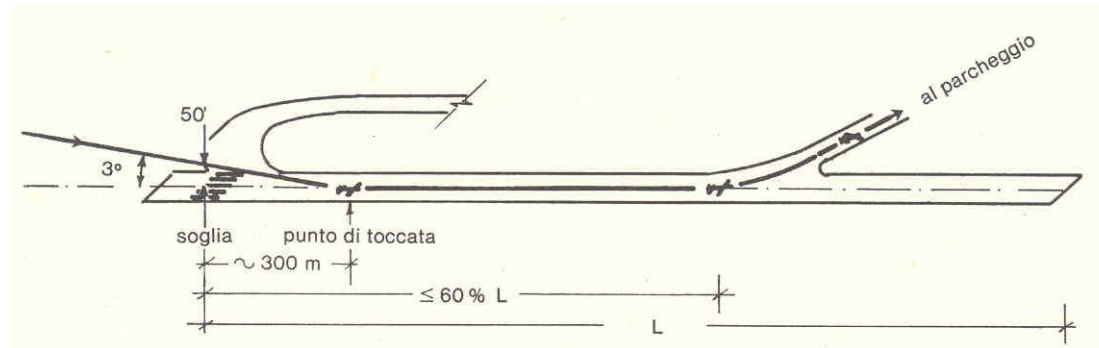

Le distanze dichiarate

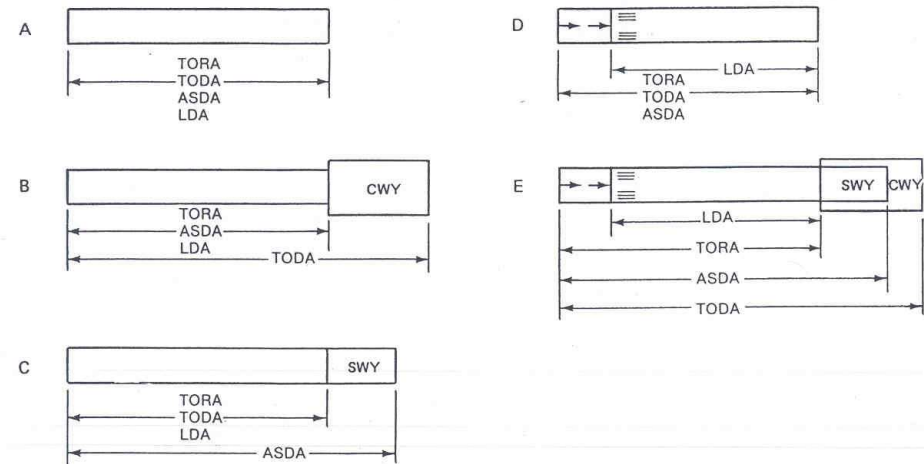
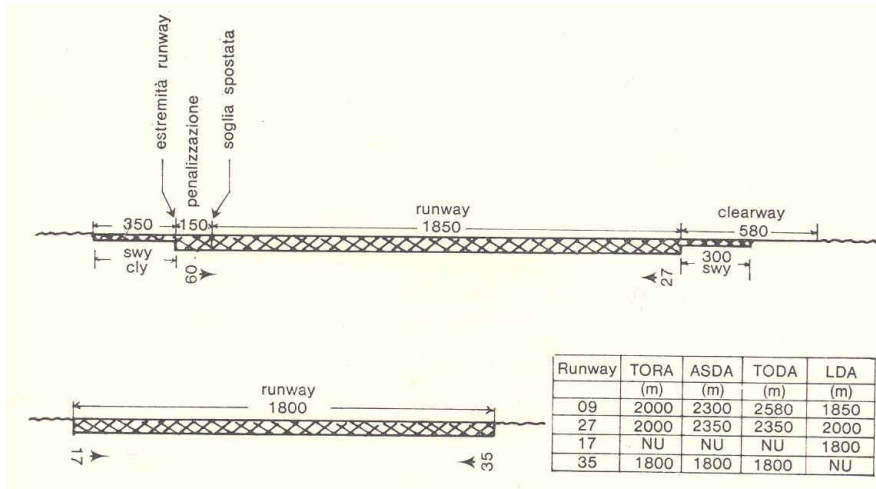

TORA (Take-Off Run Available, corsa di decollo disponibile) lunghezza di pista dichiarata disponibile e adatta alla corsa a terra di un aereo che decolla;

TODA (Take-Off Distance Available, distanza di decollo disponibile) TORA + clearway se esistente;

ASDA (Accelerate Stop Distance Available, distanza di accelerazione ed arresto disponibile) TORA + stopway se esistente;

LDA (Landing Distance Available, distanza di atterraggio disponibile) lunghezza di pista dichiarata disponibile e adatta per un aereo in fase di atterraggio;

Le distanze richieste (1)

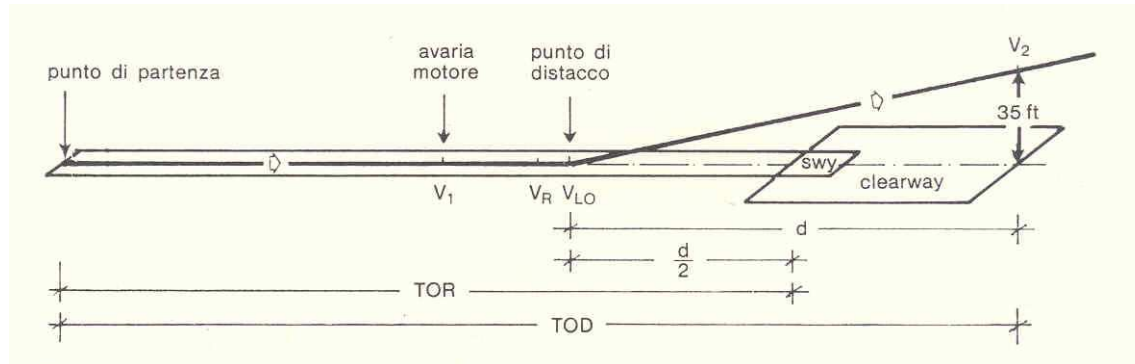

TOD (Take-Off Distance) è la maggiore delle seguenti distanze:

- Distanza orizzontale compresa fra il punto di partenza per il decollo ed il punto in cui un aeromobile con il motore critico inoperativo alla V_1 raggiunge con la sua parte più bassa la quota di 35 piedi (10,7 m);**
- La stessa distanza del punto "a", con tutti i motori operativi, incrementata del 15 %.**

TOR (Take-Off Run) è la maggiore delle seguenti distanze:

- Distanza orizzontale compresa fra il punto di partenza ed il punto intermedio fra il punto di distacco (V_{LO} Velocità di Lift-Off) ed il punto finale di decollo (quota di 35 piedi), nel caso di avaria al motore critico in corrispondenza di V_1 ;**
- La stessa distanza del punto "a" con tutti i motori operativi, incrementata del 15%.**

Le distanze richieste (2)

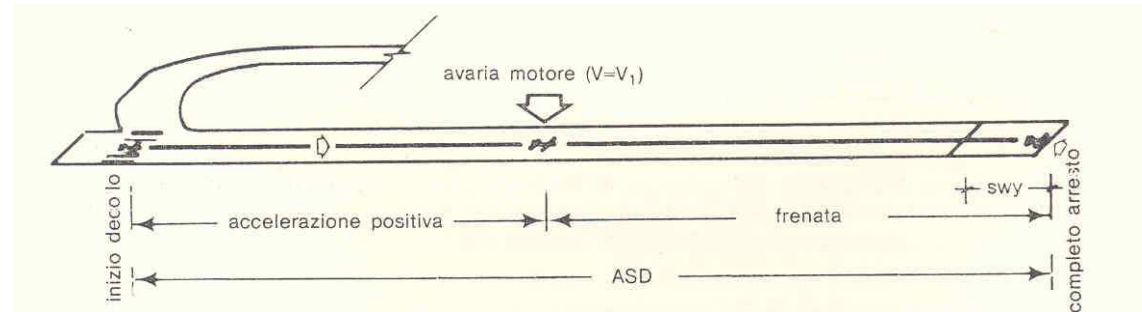

ASD (Accelerate-Stop Distance) è la distanza compresa tra il punto di inizio decollo ed il punto di completo arresto del veivolo, nel caso di avaria al raggiungimento della velocità V_1 .

Le distanze richieste (3)

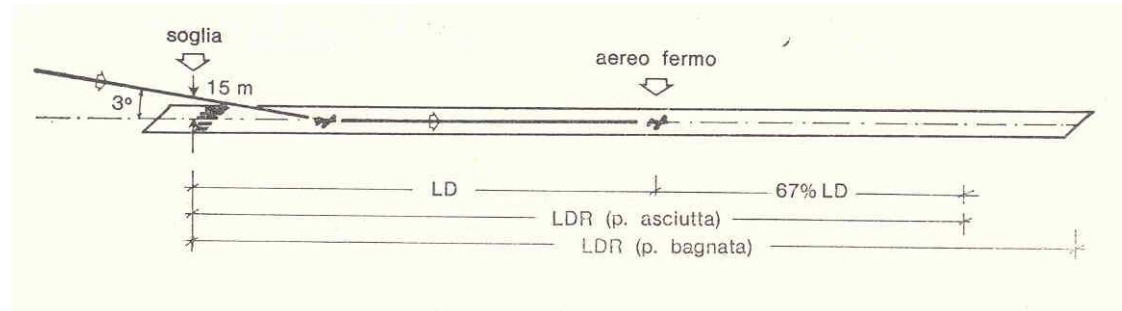

LDR (Landing Distance Required) Metodo A: è la maggiore delle seguenti distanze:

- distanza orizzontale necessaria in configurazione di atterraggio, con angolo di discesa 3° e con tutti i motori operativi per fermarsi su pista bagnata a partire da un punto alto $10,7\text{ m}$ sulla superficie di atterraggio, incrementata del 15% ;**
- La stessa distanza del punto “a” ipotizzando il motore critico inoperativo, incrementata del 10% .**

LDR (Landing Distance Required) Metodo B:

- Su pista asciutta è costituita dalla distanza orizzontale necessaria per atterrare e fermarsi a partire da 15 metri in corrispondenza della soglia, incrementata del 67% .**
- Su pista bagnata si ottiene la LDR incrementando del 15% il valore su pista asciutta precedente**

Compatibilità tra distanze richieste e dichiarate (1)

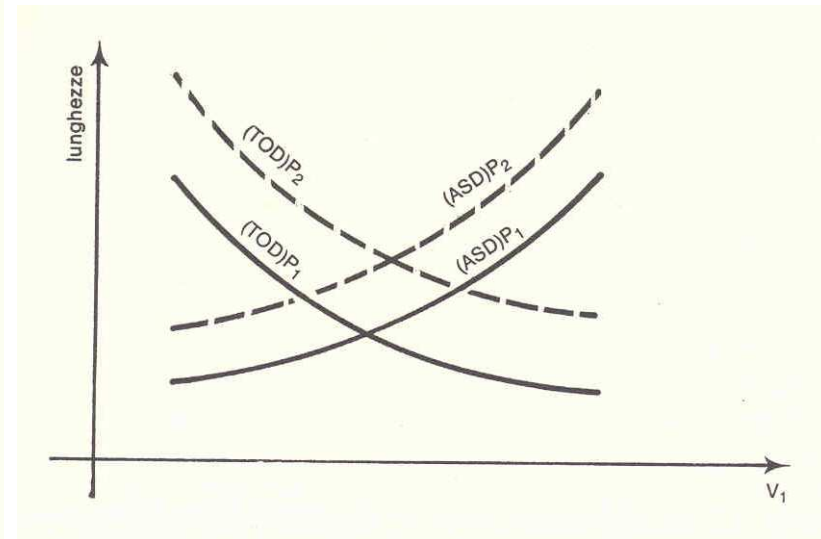
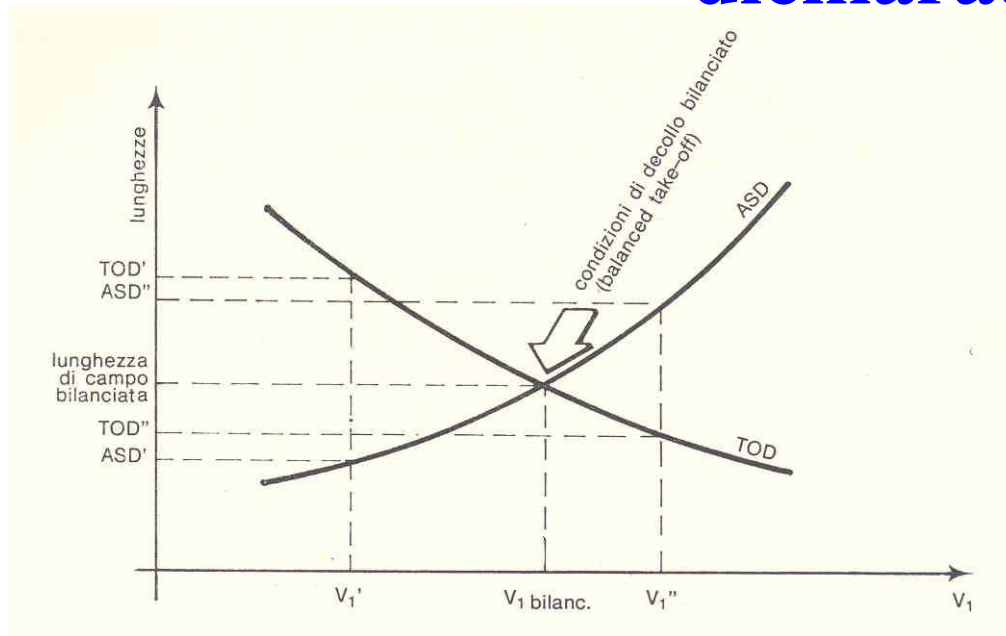

TOR < TORA

TOD < TODA

ASD < ASDA

LDR < LDA

Compatibilità tra distanze richieste e dichiarate (2)

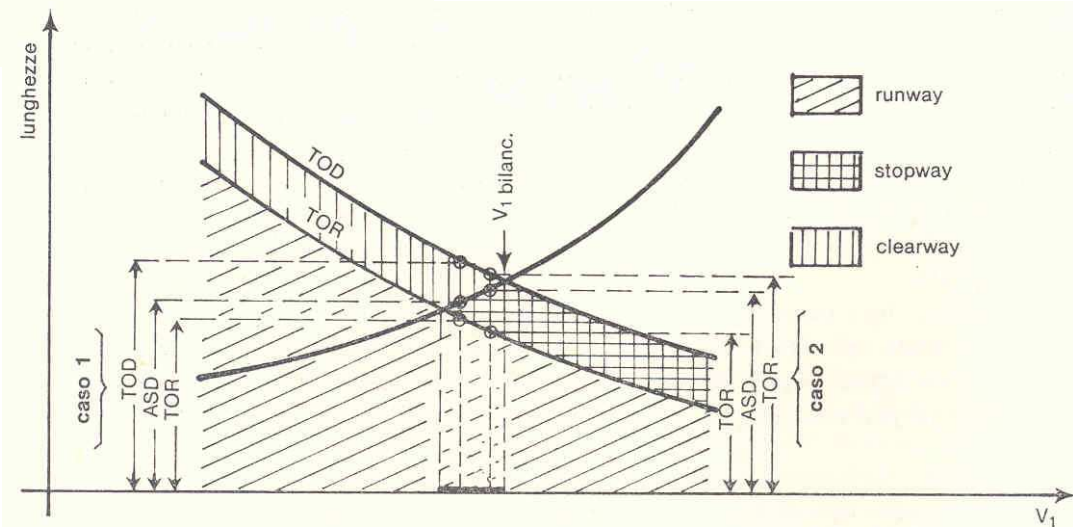
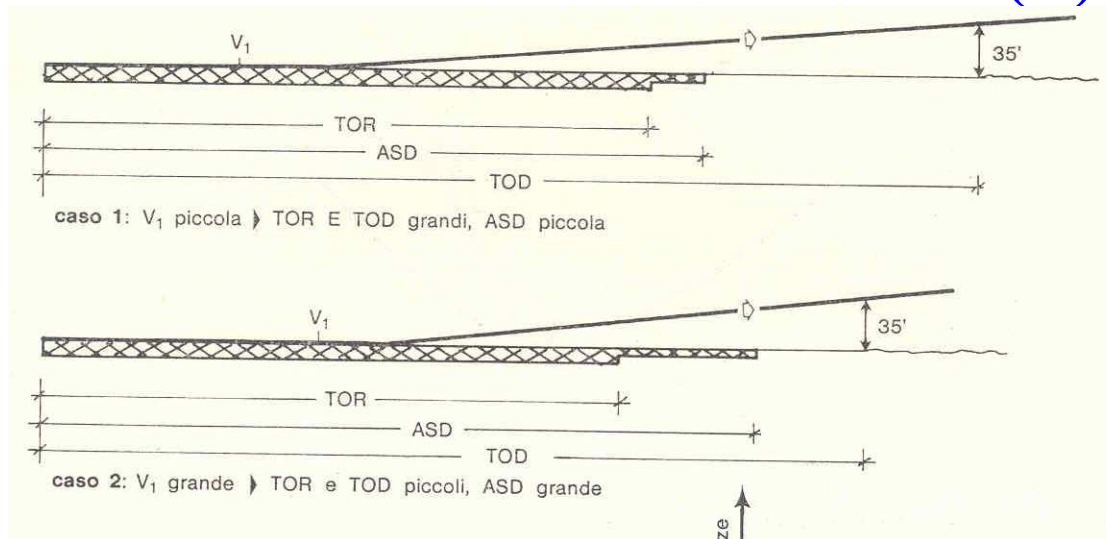

La dinamica del volo

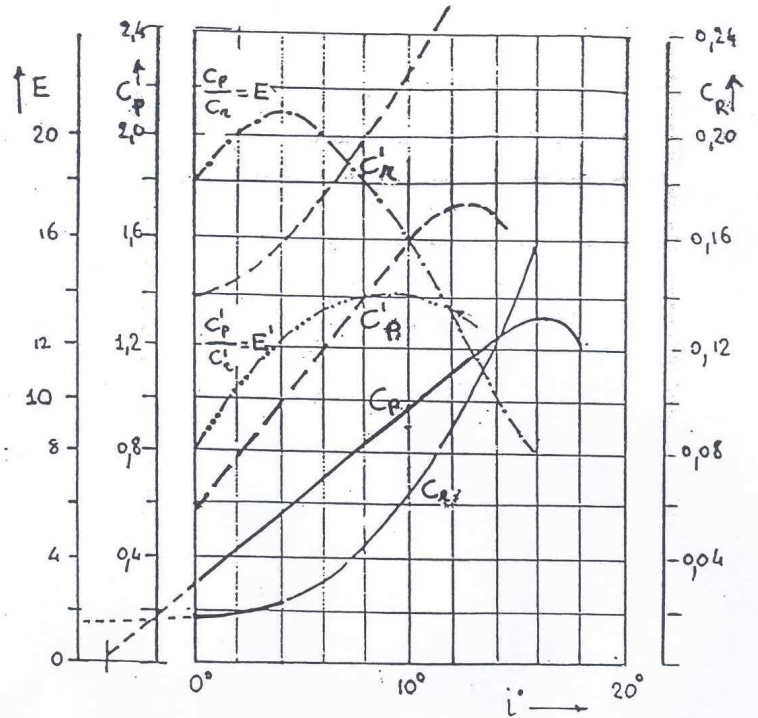
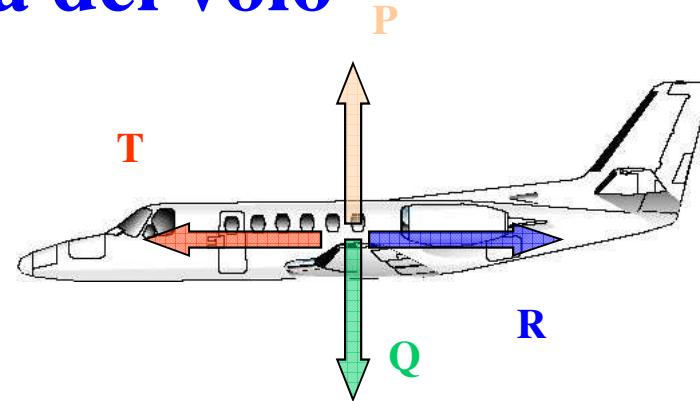
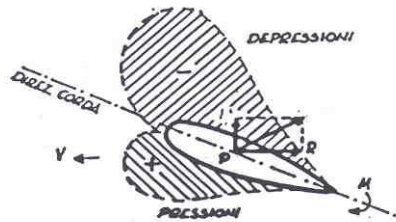

$$P = \frac{1}{2} \cdot C_p \cdot \rho \cdot S_a \cdot v^2 \quad R = \frac{1}{2} \cdot C_r \cdot \rho \cdot S_m \cdot v^2$$

$$Q = P = \frac{1}{2} \cdot C_{p,d} \cdot \rho \cdot S_a \cdot v_d^2 = \frac{1}{2} \cdot C_{p,c} \cdot \rho \cdot S_a \cdot v_c^2$$

$$C_{p,d} \cdot v_d^2 = C_{p,c} \cdot (3,5 \cdot v_d)^2$$

$$\frac{C_{p,d}}{C_{p,c}} = (3,5)^2 = 12,25$$

Lo spazio di decollo (1)

$$R_{\text{aer.}} = \frac{1}{2} \cdot C_r \cdot \rho \cdot S_m \cdot v^2$$

$$R_{\text{rot.}} = f_{\text{rot.}} \cdot \left(Q - \frac{1}{2} \cdot C_p \cdot \rho \cdot S_a \cdot v^2 \right)$$

$$R = R_{\text{aer.}} + R_{\text{rot.}}$$

$$T - R = \frac{Q}{g} \cdot a$$

$$ds = v \cdot dt = v \cdot \frac{dv}{a}$$

$$S_1 = \int_{v=0}^{v_R} \frac{v}{a} \cdot dv$$

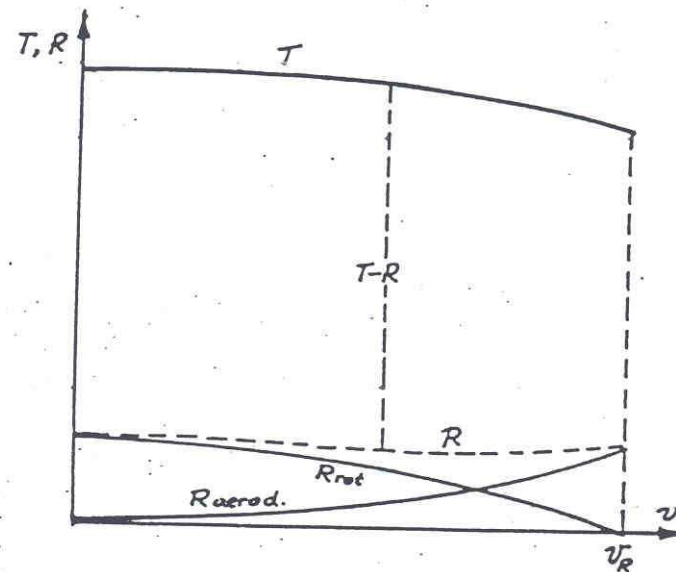
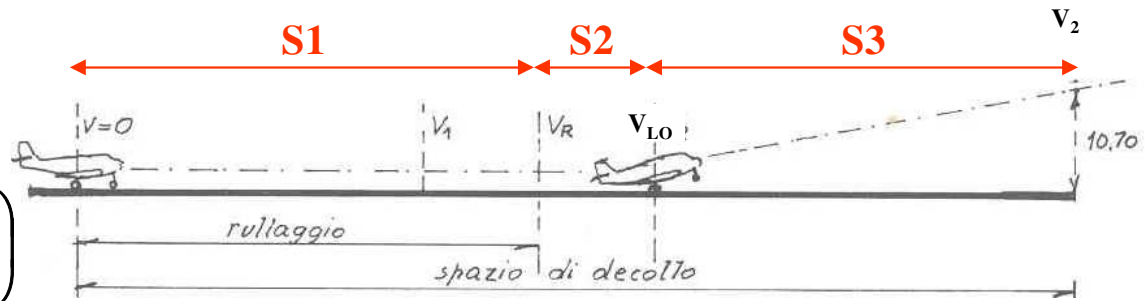

Lo spazio di decollo (2)

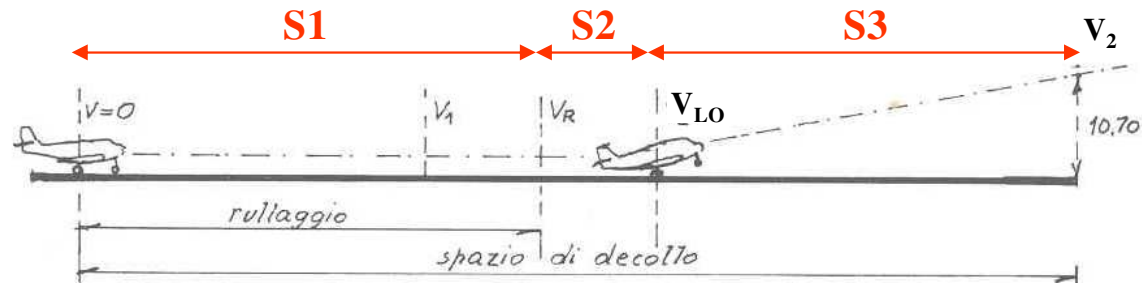

$$S_1 = \int_{v=0}^{v_R} \frac{v}{a} \cdot dv$$

$$S_2 = v_m \cdot t_m$$

$$S_3 = 10,7 \cdot \text{tg}(3^\circ)$$

$$v_m = \frac{v_R + v_2}{2}$$

$$t_m \cong 3 \text{ [s]}$$

Fattori che influenzano lo spazio di decollo

$$Q = P = \frac{1}{2} \cdot C_p \cdot \rho_0 \cdot S_a \cdot v_0^2 = \frac{1}{2} \cdot C_p \cdot \rho_h \cdot S_a \cdot v_h^2$$

$$v_h = \frac{v_0}{\sqrt{\frac{\rho_h}{\rho_0}}} = \frac{v_0}{\sqrt{\delta}}$$

TABELLA V.1 - Aria: tipo internazionale (unità tecniche)

Quota campo m	Temperatura media °C	Pressione mm (Hg)	Peso specifico γ kg _p /m ³	Densità ρ kg _p /m ³	Densità relativa $\delta = \rho/\rho_0$
0	15	760	1,2250	0,1249	1
500	11,75	715,9	1,1673	0,1190	0,9528
1000	8,50	674,1	1,1117	0,1133	0,9075
1500	5,25	634,2	1,0581	0,1079	0,8638
2000	2,00	596,2	1,0064	0,1026	0,8216
2500	-1,25	560,1	0,9569	0,0975	0,7810
3000	-4,50	525,8	0,9091	0,0927	0,7421

$$L_{\text{real.}} = L_{\text{base}} K1 * K2 * K3$$

$$K1 = 1 + 0,07 * (H/300)$$

$$K2 = 1 + 0,01 * (T_R - T_S)$$

$$K3 = 1 + 0,1 * (i)$$

$$T_S = 15 - 0,0065 * H$$

Esempio di calcolo

$L_{\text{base}} = 1700 \text{ m};$ **Quota aeroporto: $H = 150 \text{ m};$**

Temperatura di riferimento $T_R = 24 \text{ }^\circ$ **Pendenza media pista $i = 0,5 \text{ } \%$**

$T_S = 15 - 0,0065 * H = 14,025 \text{ }^\circ$

$L_{\text{real.}} = L_{\text{base}} * K1 * K2 * K3 = 1700 * 1,035 * 1,100 * 1,050 \cong 2033$

$K1 = 1 + 0,07 * (H/300) = 1 + 0,07 * (150/300) = 1,035$

$K2 = 1 + 0,01 * (T_R - T_S) = 1 + 0,01 * (24 - 14,025) = 1,100$

$K3 = 1 + 0,1 * (i) = 1 + 0,1 (0,5) = 1,050$

Lo spazio di atterraggio

$$S_1 = 15 \cdot \operatorname{tg}(3^\circ)$$

$$S_2 = v_m \cdot t_m$$

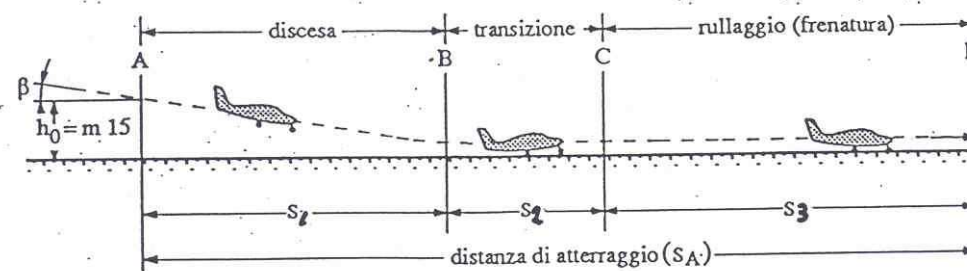

$$Q = m \cdot g = \frac{1}{2} \cdot C_p \cdot \rho \cdot S_a \cdot v_a^2$$

$$\frac{Q}{g} \cdot \frac{dv}{dt} = - \left[f \cdot Q + \frac{1}{2} (C_r - f \cdot C_p) \cdot \rho \cdot S_a \cdot v^2 \right]$$

$$ds = v \cdot dt = v \cdot \frac{dv}{a}$$

$$\frac{v}{g} \cdot \frac{dv}{ds} = - \left[f + \left(\frac{C_r}{C_p} - f \right) \cdot \frac{v^2}{v_a^2} \right]$$

$$\mu = \frac{C_r}{C_p}$$

$$S_3 = \frac{\ln \frac{f}{\mu}}{2 \cdot (f - \mu) \cdot g} \cdot v_a^2$$

I diagrammi di prestazione (1)

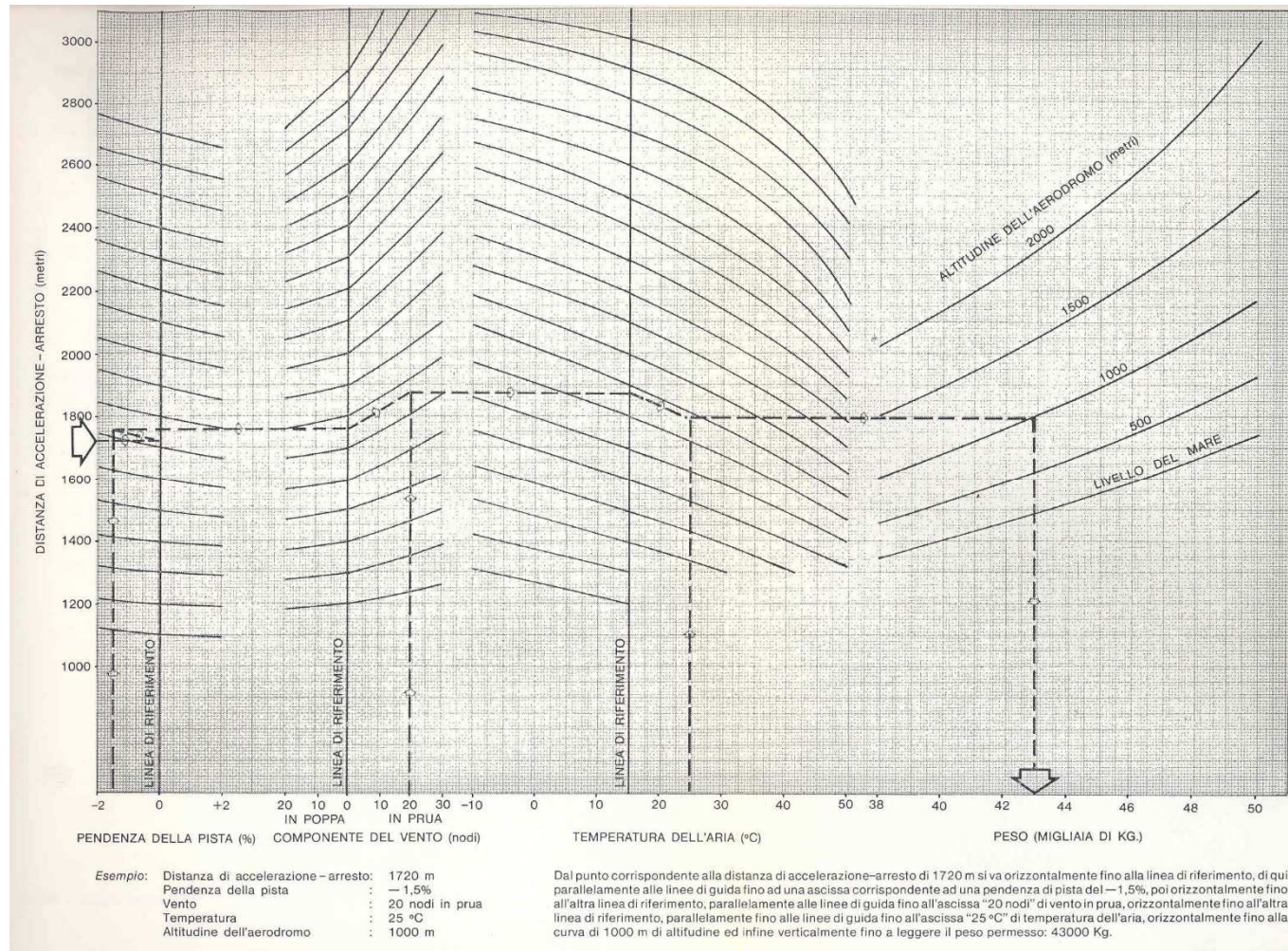

I diagrammi di prestazione (2)

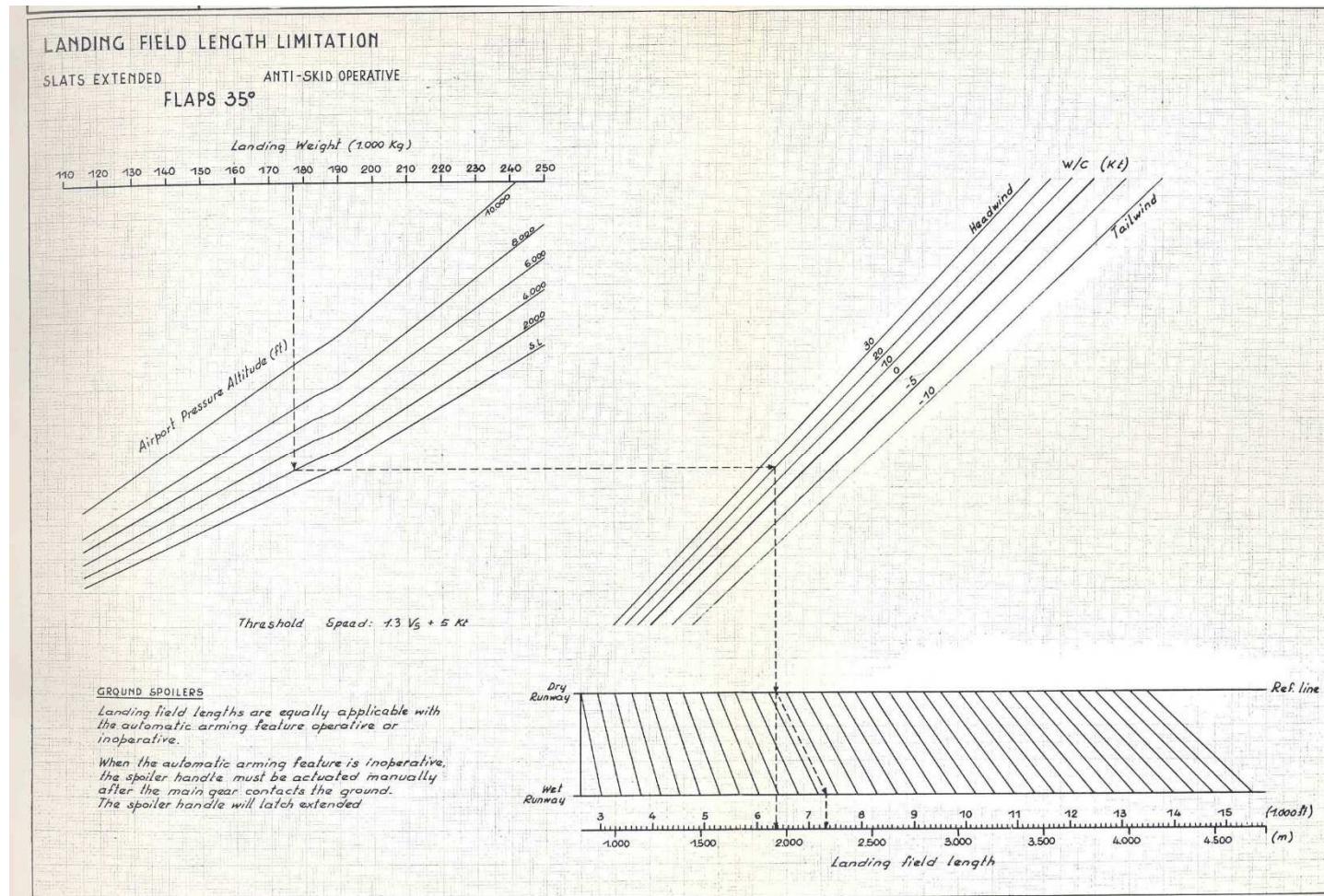

Larghezza della runway (1)

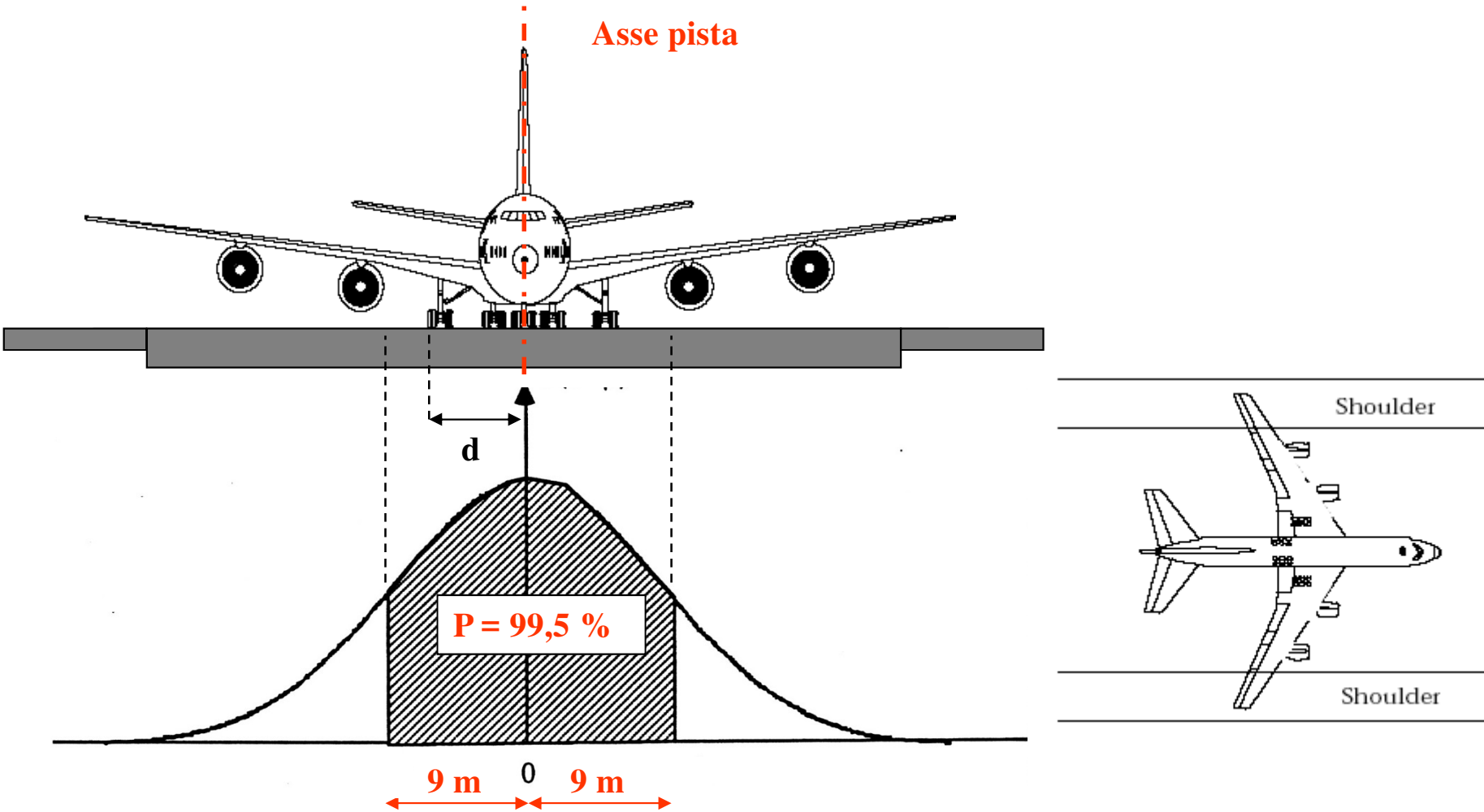

Larghezza della runway (2)

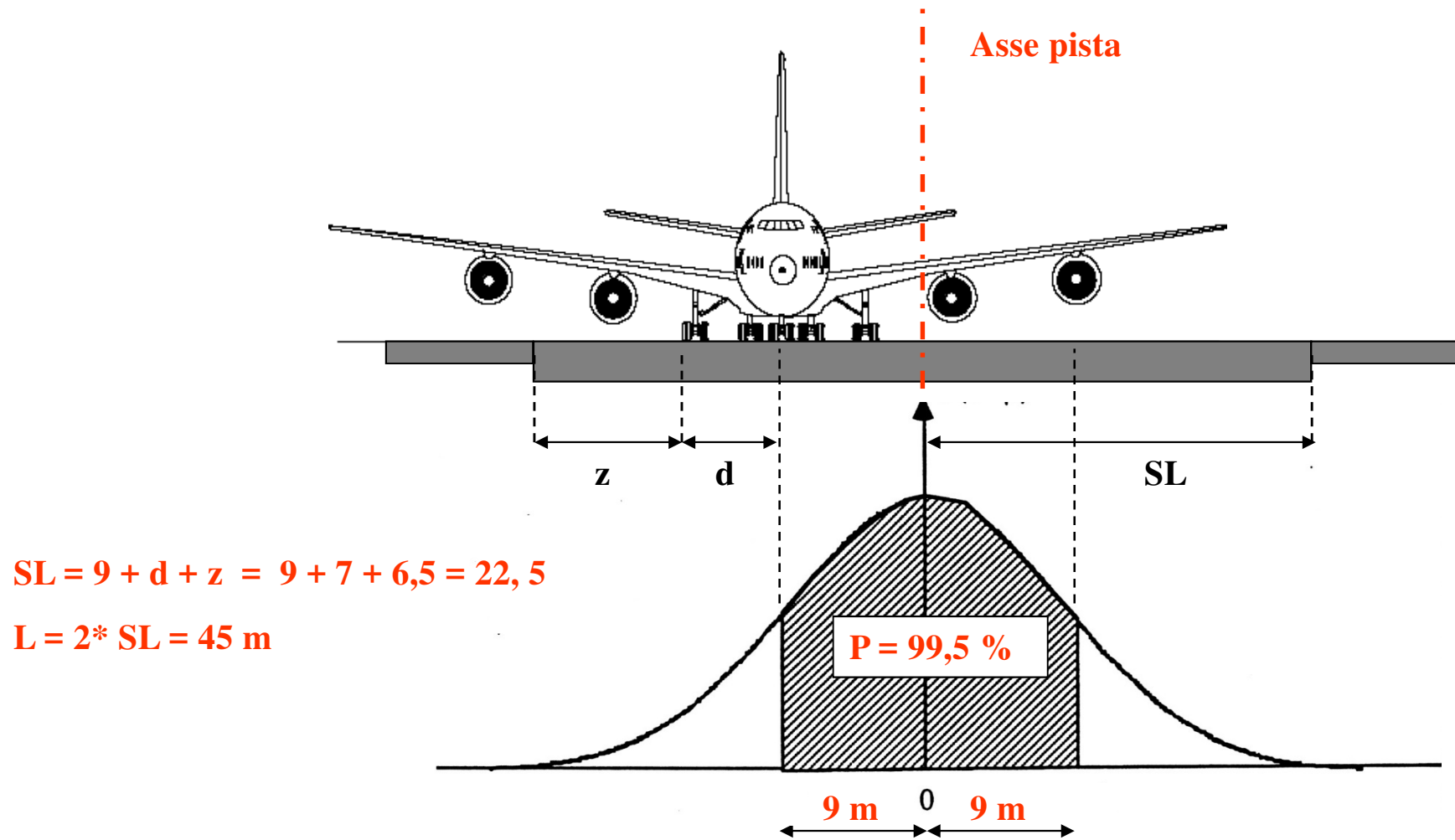

Larghezza della runway (3)

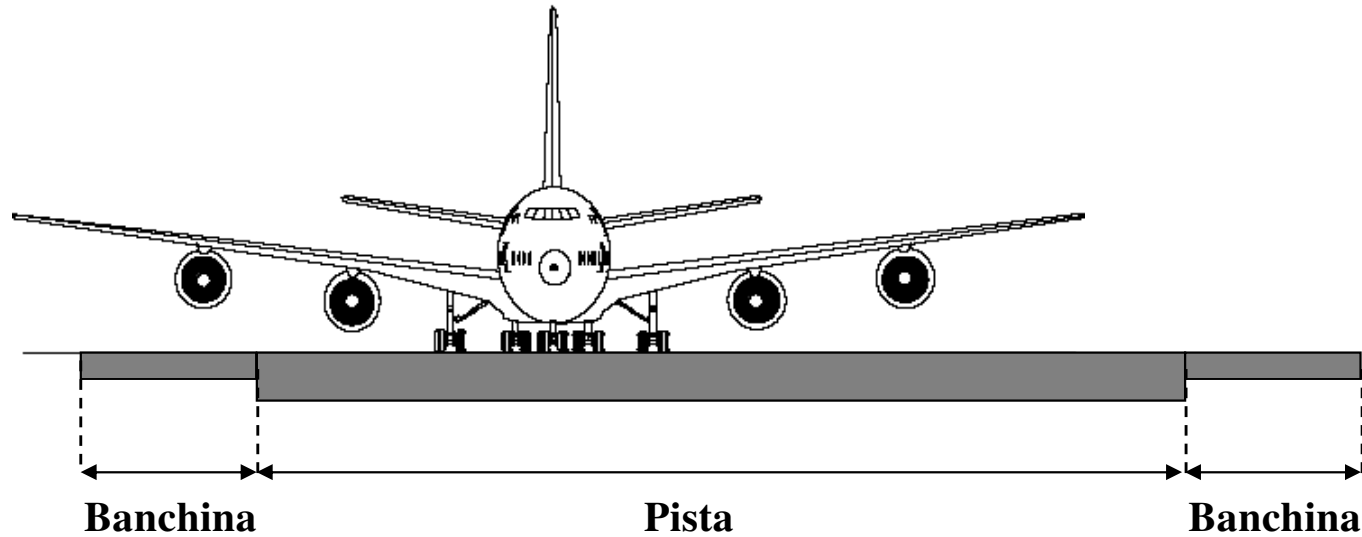

Cod. alfabetico	A	B	C	D	E	F
Cod. numerico	[m]	[m]	[m]	[m]	[m]	[m]
1	18	18	23			
2	23	23	30			
3	30	30	30	45		
4			45	45	45	60

Pendenze longitudinali della runway (1)

Cod. numerico	1	2	3	4
Pendenza longitudinale media (Hmax – Hmin)/L	≤ 2 %	≤ 2 %	≤ 1 %	≤ 1 %
Pendenza massima	≤ 2 %	≤ 2 %	≤ 1,5 %	≤ 1,25 %
Pendenza massima I e IV quarto	-	-	≤ 0,8 % *	≤ 0,8 %
Variazione di pendenza	≤ 2 %	≤ 2 %	≤ 1,5 %	≤ 1,5 %
Raggio raccordi verticali	≥ 7.500 m	≥ 7.500 m	≥ 15.000 m	≥ 30.000 m

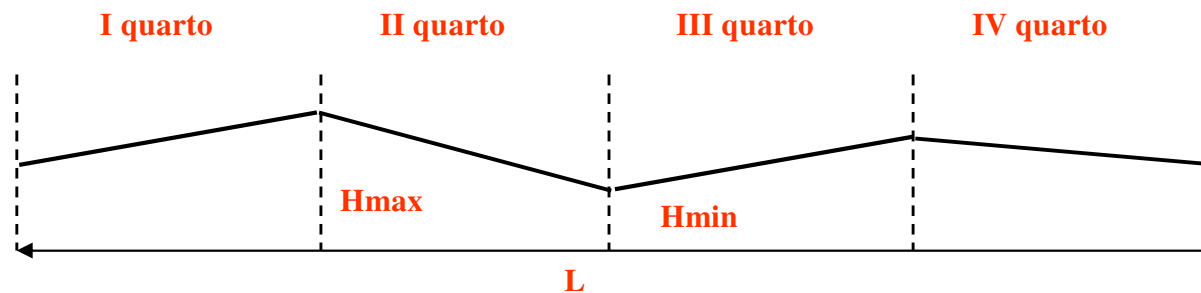

Pendenze longitudinali della runway (2)

Cod. numerico	1	2	3	4
A	5.000 m	5.000 m	15.000 m	30.000 m
R	7.500 m	7.500 m	15.000 m	30.000 m

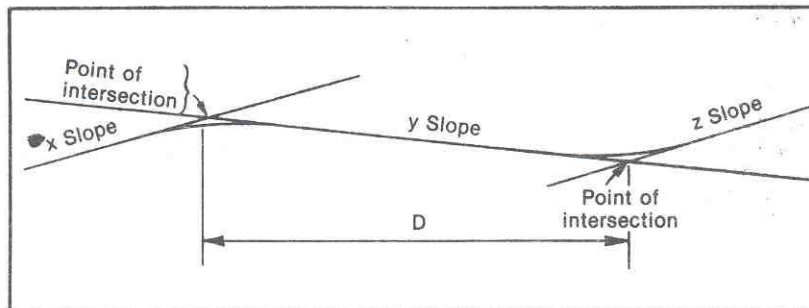

$$D \geq A * (|x - y| + |y - z|)$$

$$D \geq 45 \text{ m}$$

Distanze visibilità

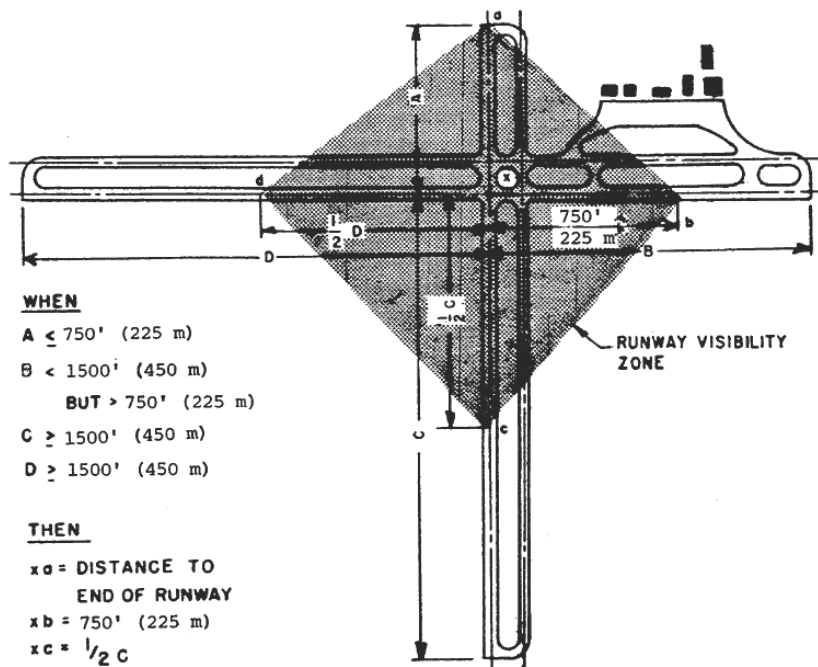

WHEN

- A \leq 750' (225 m)
- B $<$ 1500' (450 m)
BUT $>$ 750' (225 m)
- C \geq 1500' (450 m)
- D \geq 1500' (450 m)

THEN

- x_a = DISTANCE TO
END OF RUNWAY
- x_b = 750' (225 m)
- x_c = $\frac{1}{2}$ C
- x_d = $\frac{1}{2}$ D

Cod. alfabetico	A	B	C	D	E	F
	[m]	[m]	[m]	[m]	[m]	[m]
h1	1,5	2	3	3	3	3
h2	1,5	2	3	3	3	3
Distanza di vis.	L/2	L/2	L/2	L/2	L/2	L/2

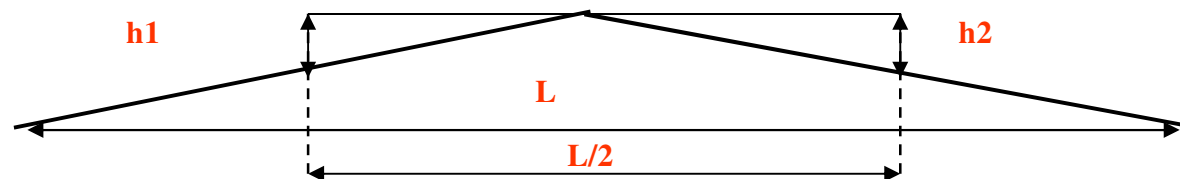

Sezione trasversale

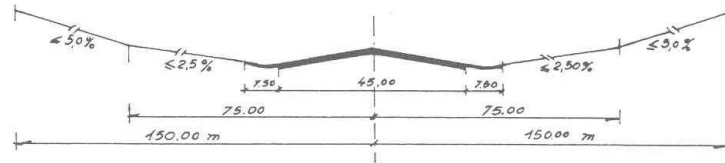

A) SEZIONE TRASVERSALE

Runway End Safety Area

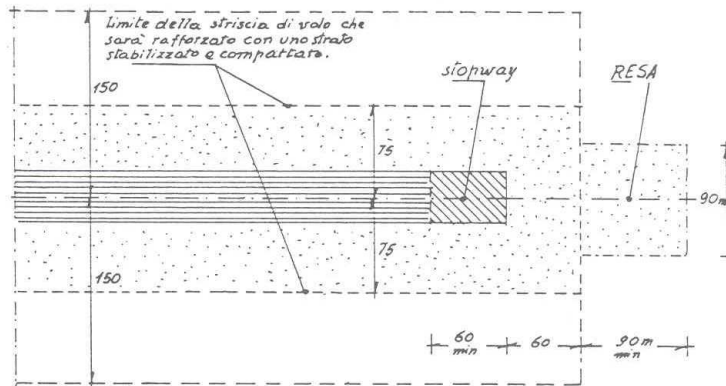

B) PIANTA

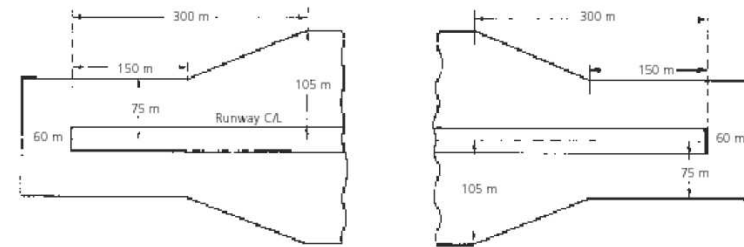

Code number

1 2 3 4

Runway

maximum transverse slope

2% where the code letter is A or B; and 1.5% where the code letter is C, D, or E

Width of runway strip

precision and non-precision runway
non-instrument runway

	1	2	3	4
precision and non-precision runway	150 m	150 m	300 m	300 m
non-instrument runway	60 m	80 m	150 m	150 m

Strip

maximum longitudinal slope
maximum transverse slope

	1	2	3	4
maximum longitudinal slope	2%	2%	1.75%	1.5%
maximum transverse slope	3%	3%	2.5%	2.5%

Larghezza piste di circolazione

Physical characteristics	Code letter				
	A	B	C	D	E
Minimum width of:					
taxiway pavement	7.5 m	10.5 m	18 m ^a 15 m ^b	23 m ^c 18 m ^d	23 m
taxiway pavement and shoulder	—	—	25 m	38 m	44 m
taxiway strip	27 m	39 m	57 m	85 m	93 m
graded portion of taxiway strip	22 m	25 m	25 m	38 m	44 m
Minimum clearance distance of outer main wheel to taxiway edge	1.5 m	2.25 m	4.5 m ^a 3 m ^b	4.5 m	4.5 m
Maximum longitudinal slope of taxiway:					
pavement	3%	3%	1.5%	1.5%	1.5%
change in slope	1% per 25 m	1% per 25 m	1% per 30 m	1% per 30 m	1% per 30 m
Maximum transverse slope of:					
taxiway pavement	2%	2%	1.5%	1.5%	1.5%
graded portion of taxiway strip upwards	3%	3%	2.5%	2.5%	2.5%
graded portion of taxiway strip downwards	5%	5%	5%	5%	5%
ungraded portion of strip upwards	5%	5%	5%	5%	5%
Minimum radius of longitudinal vertical curve	2 500 m	2 500 m	3 000 m	3 000 m	3 000 m
Minimum taxiway sight distance	150 m from 1.5 m above	200 m from 2 m above	300 m from 3 m above	300 m from 3 m above	300 m from 3 m above

C

F

30.5 m
55 m
115 m
60 m
6 m

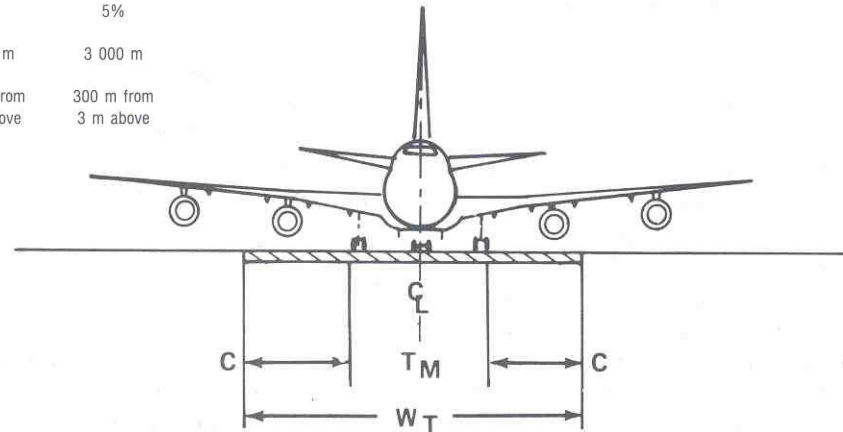
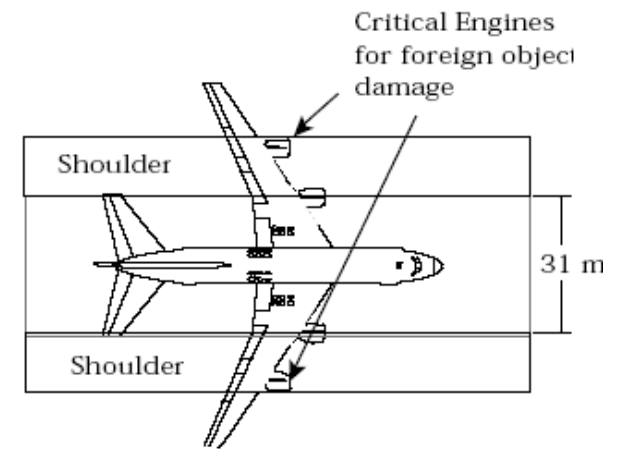

Le distanze di separazione (1)

Physical characteristics	Code letter					F
	A	B	C	D	E	
Minimum separation distance between taxiway centre line and:						
centre line of instrument runway code number 1	82.5 m	87 m	—	—	—	
2	82.5 m	87 m	—	—	—	
3	—	—	168 m	176 m	—	
4	—	—	—	176 m	182.5 m	190 m
centre line of non-instrument runway code number 1	37.5 m	42 m	—	—	—	
2	47.5 m	52 m	—	—	—	
3	—	—	93 m	101 m	—	115 m
4	—	—	—	101 m	107.5 m	97.5 m
taxiway centre line	23.75 m	33.5 m	44 m	66.5 m	80 m	57.5 m
object						
taxiway ^e	16.25 m	21.5 m	26 m	40.5 m	47.5 m	50.5 m
aircraft stand taxilane	12 m	16.5 m	24.5 m	36 m	42.5 m	

Tabella 3.4 - Distanze di separazione delle taxiway

Lettera di codice	Distanze tra asse pista e asse delle taxiway								Distanza interasse taxiway	Distanza tra asse taxiway e manufatti, escluse vie d'accesso alle piazzole	Distanza tra manufatti e asse vie di accesso alle piazzole
	Piste strumentali				Piste non strumentali						
	Numero di codice				Numero di codice						
	1	2	3	4	1	2	3	4			
(1)	(2)	(3)	(4)	(5)	(6)	(7)	(8)	(9)	(10)	(11)	(12)
A	82,5	82,5			37,5	47,5			23,75	16,25	12
B	87	87			42	52			33,5	21,5	16,5
C			168				93		44	26	24,5
D			176	176			101	101	66,5	40,5	36
E				182,5					107,5	80	47,5
F				190					115	97,5	50,5

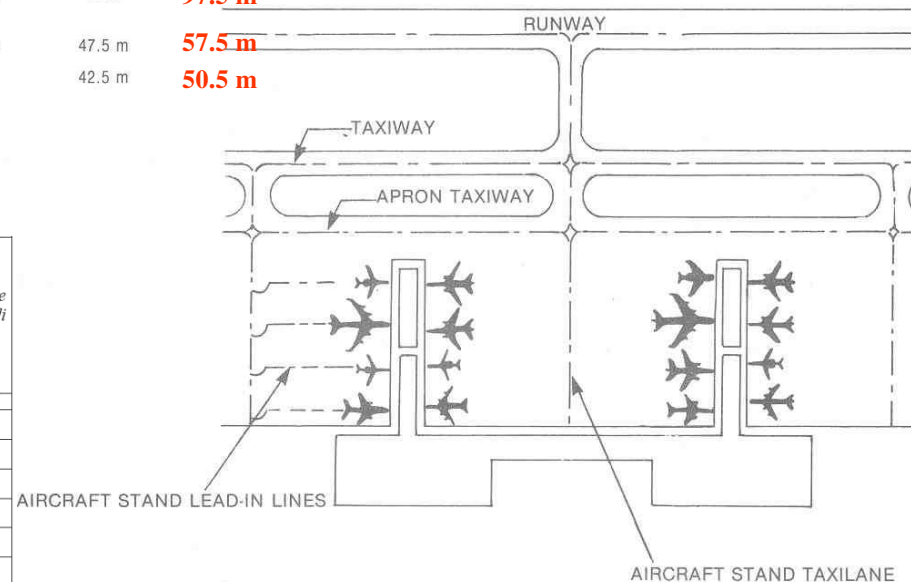

Le distanze di separazione (2)

Code number	1		2		3				4			
Code letter	A	B	A	B	A	B	C	D	C	D	E	F
1/2 wing span (Y) + 1/2 strip width (non-instrument approach runway)	7.5	12	7.5	12	7.5	12	18	26	18	26	32.5	
Total	30.0	30	40.0	40	75.0	75	75	75	75	75	75.0	
	37.5	42	47.5	52	82.5	87	93	101	93	101	107.5	115
or												
1/2 wing span (Y) + 1/2 strip width (instrument approach runway)	7.5	12	7.5	12	7.5	12	18	26	18	26	32.5	
Total	75.0	75	75.0	75	150.0	150	150	150	150	150	150.0	
	82.5	87	82.5	87	157.5	162	168	176	168	176	182.5	190

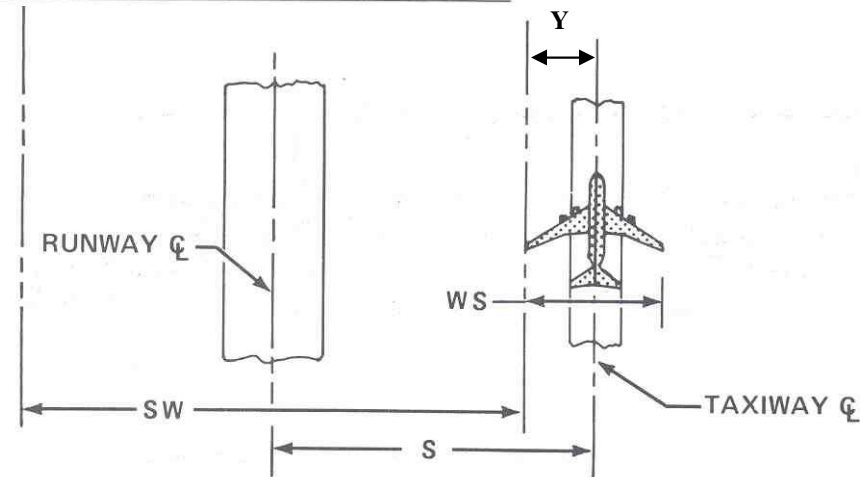

Le distanze di separazione (3)

Separation distances	Code letter					
	A	B	C	D	E	F
Between apron taxiway/taxiway centre line and taxiway centre line:						
wing span (WS)	15.00	24.00	36	52.0	65.0	
+ maximum lateral deviation (C)	1.50	2.25	3	4.5	4.5	
+ increment (Z)	7.25	7.25	5	10.0	10.5	
Total separation distance (S)	23.75	33.50	44	66.5	80.0	97,5

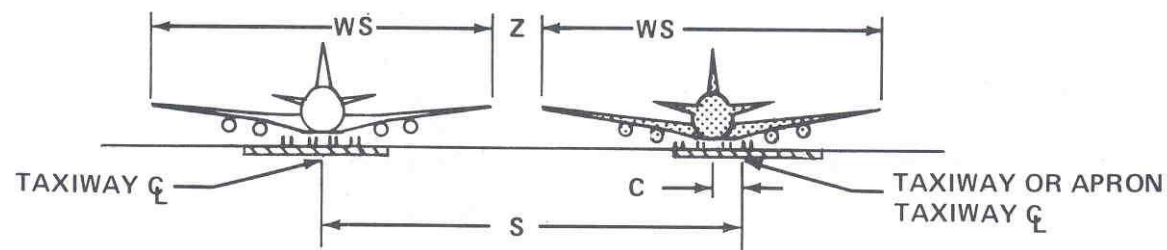

Le distanze di separazione (4)

Separation distances	Code letter					F
	A	B	C	D	E	
Between taxiway centre line and object:						
½ wing span (Y)	7.50	12.00	18	26.0	32.5	
+ maximum lateral deviation (C)	1.50	2.25	3	4.5	4.5	
+ increment (Z)	7.25	7.25	5	10.0	10.5	
Total separation distance (S)	16.25	21.50	26	40.5	47.5	57,5
Between apron taxiway centre line and object:						
½ wing span (Y)	7.50	12.00	18	26.0	32.5	
+ maximum lateral deviation (C)	1.50	2.25	3	4.5	4.5	
+ increment (Z)	7.25	7.25	5	10.0	10.5	
Total separation distance (S)	16.25	21.50	26	40.5	47.5	57,5

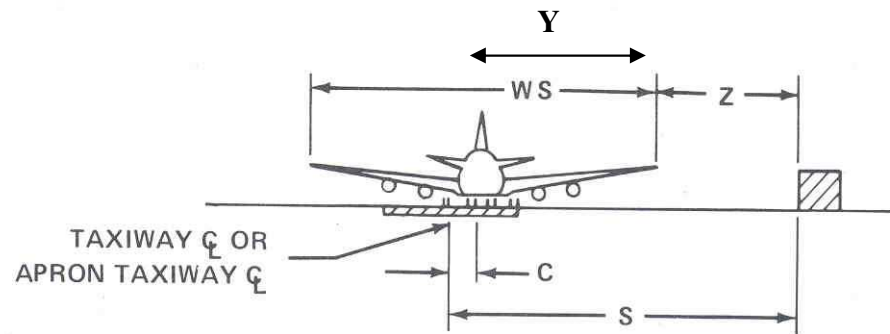

Le distanze di separazione (5)

Separation distances	Code letter					F
	A	B	C	D	E	
Between aircraft stand taxilane centre line and object:						
1/2 wing span (Y)	7.5	12.00	18.0	26.0	32.5	
+ gear deviation	1.5	1.50	2.0	2.5	2.5	
+ increment (Z)	3.0	3.00	4.5	7.5	7.5	
Total separation distance (V)	12.0	16.50	24.5	36.0	42.5	50,5

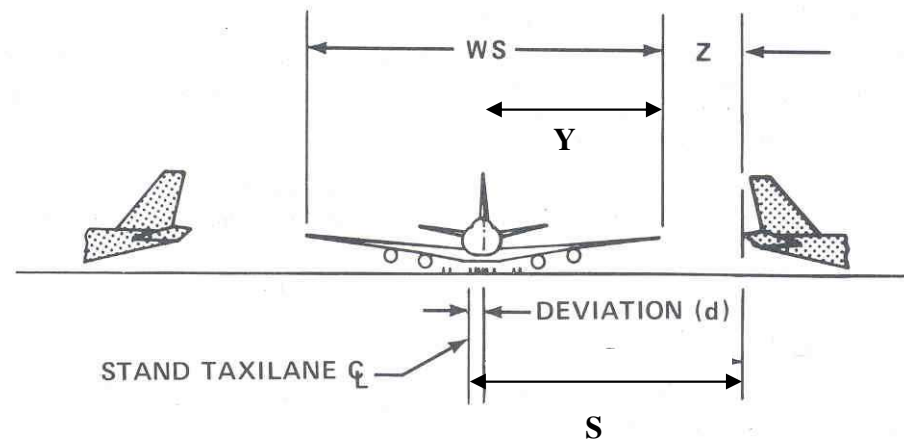

Le curve delle taxiway (1)

$$\frac{V^2}{R} = 127,133 \cdot [\cancel{\text{tg}(\alpha)} + f_T]$$

↑
0,133

Speed (km/h)	Radius of curve (m)
16	15
32	60
48	135
64	240
80	375
96	540

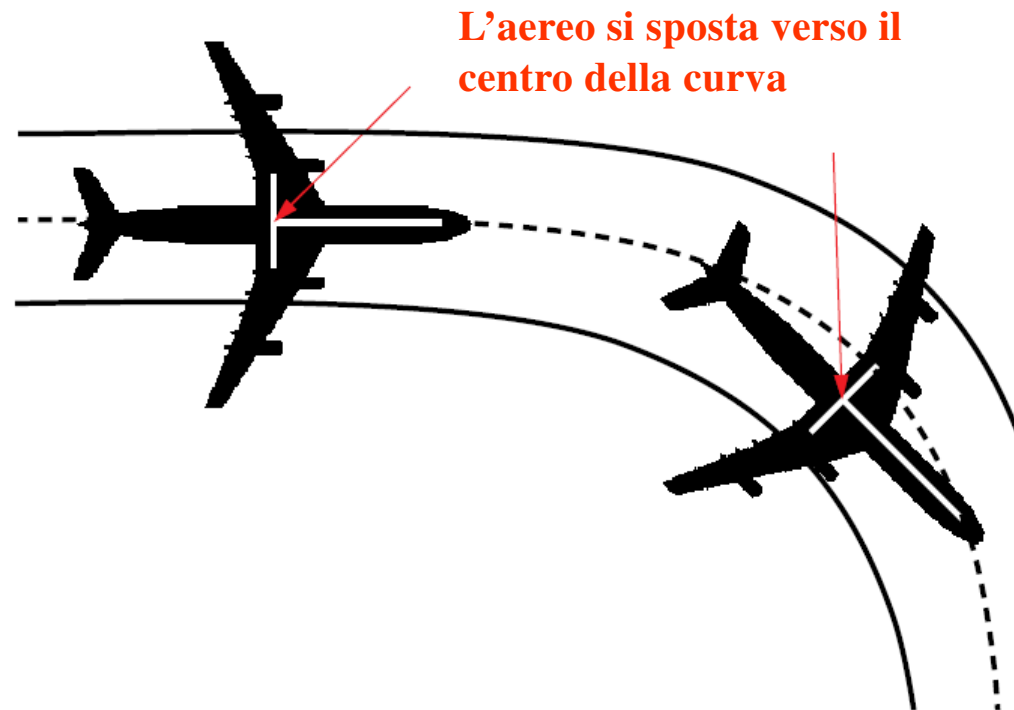

Le curve delle taxiway (2)

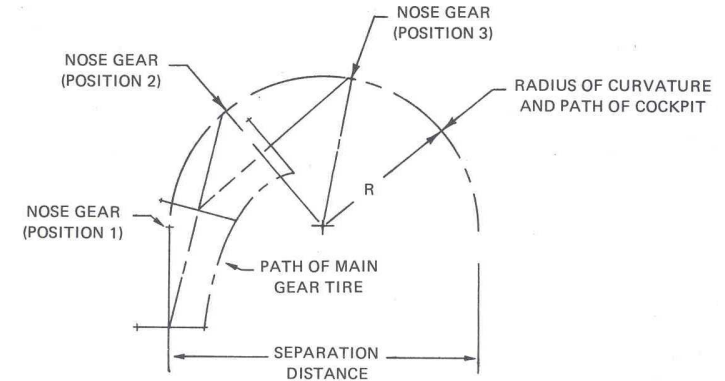
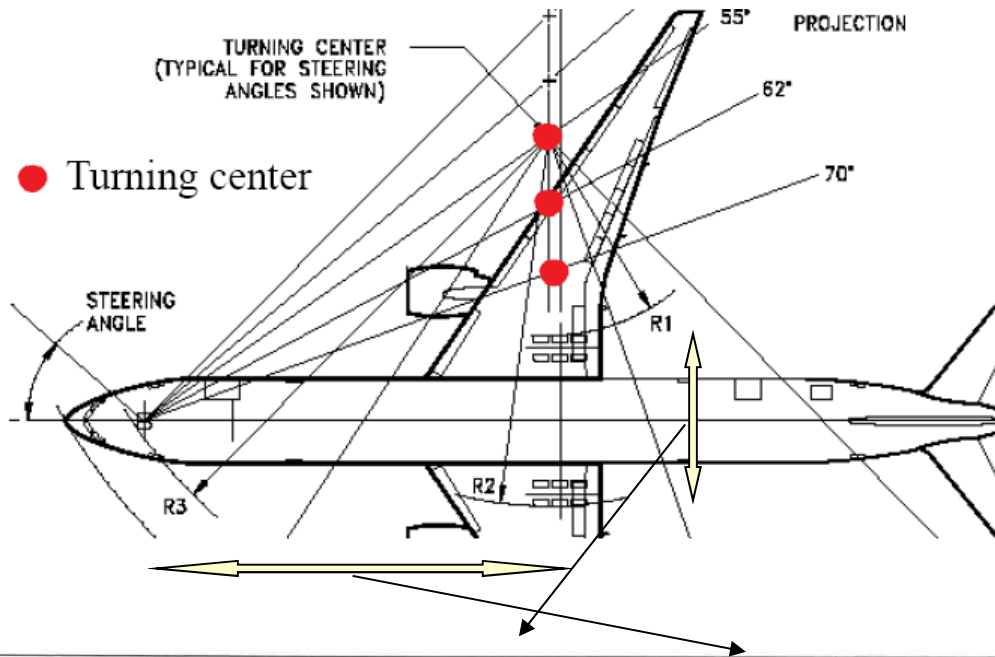

Aircraft model	Maximum steering angle	Approx. maximum steering angle during 180° turn
Lear 55	55°	40°
F28-2000	76°	45°
MD80	82°	65°
Concorde	60°	85°
MD11	70°	60°
B747	70°	50°

Code letter	Aircraft model	Outer main gear wheel span (m)	Main gear to cockpit (m)	Radius of curvature (m)
A	Lear 55	4.5	5.7	11.875
B	F28-2000	6.0	11.9	16.75
C	MD80	9.0	20.3	22.0
C	Concorde	9.0	29.6	22.0
D	MD11	14.0	31.0	33.25
E	B747	14.0	28.0	40.0

Code letter	Radius (m)	Velocity $V = 4.1120 (R^{1/2})$ (km/h)
A	11.875	14.17
B	16.75	16.83
C	22.0	19.29
D	33.25	23.71
E	40.0	26.01

I raccordi planimetrici nelle taxiway (1)

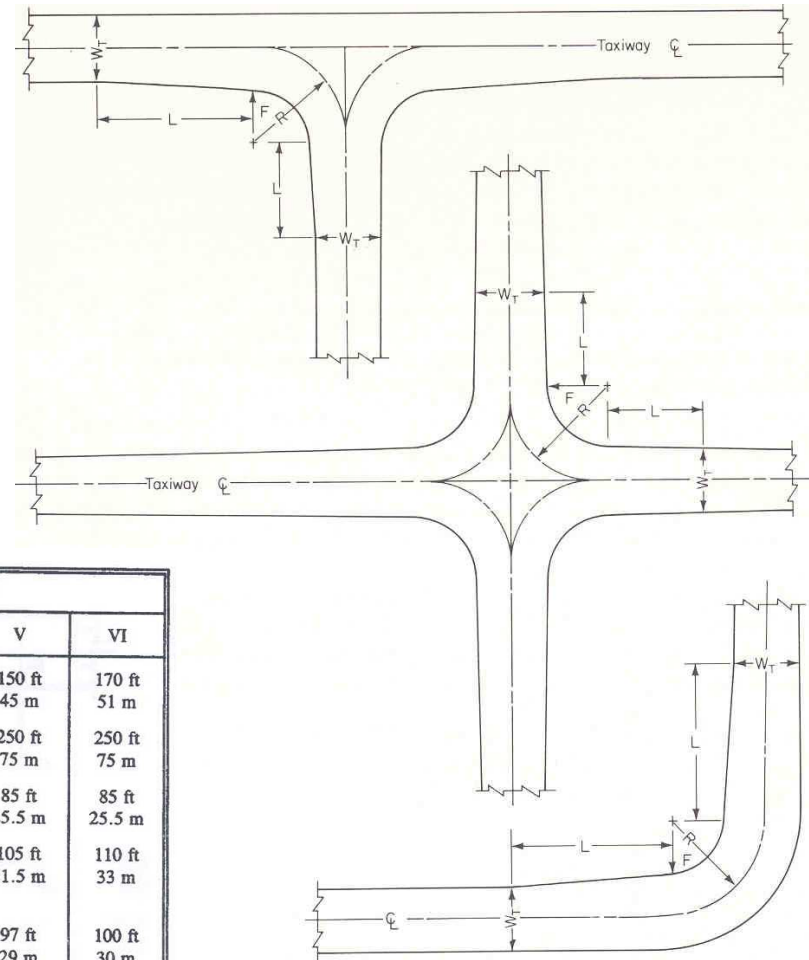
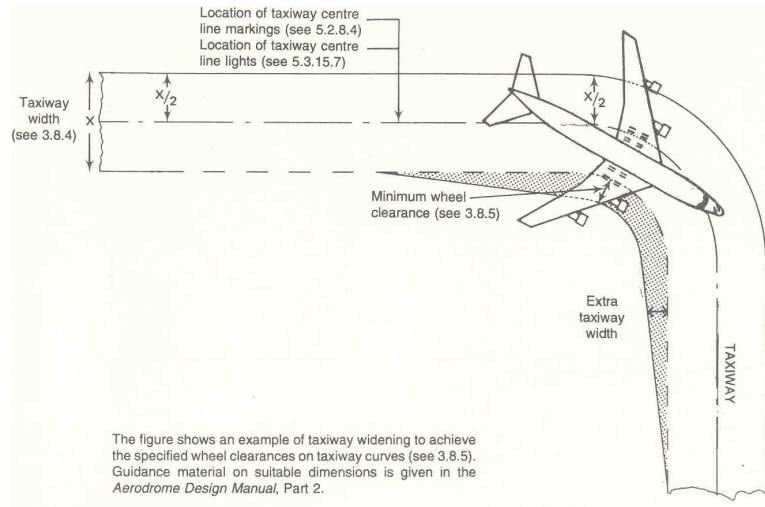

ITEM	DIM 1/	AIRPLANE DESIGN GROUP					
		I	II	III 2/	IV	V	VI
Radius of Taxiway Turn 3/	R	75 ft 22.5 m	75 ft 22.5 m	100 ft 30 m	150 ft 45 m	150 ft 45 m	170 ft 51 m
Length of Lead-in to Fillet	L	50 ft 15 m	50 ft 15 m	150 ft 45 m	250 ft 75 m	250 ft 75 m	250 ft 75 m
Fillet Radius for Tracking Centerline	F	60 ft 18 m	55 ft 16.5 m	55 ft 16.5 m	85 ft 25.5 m	85 ft 25.5 m	85 ft 25.5 m
Fillet Radius for Judgmental Oversteering Symmetrical Widening 4/	F	62.5 ft 18.75 m	57.5 ft 17.25 m	68 ft 20.4 m	105 ft 31.5 m	105 ft 31.5 m	110 ft 33 m
Fillet Radius for Judgmental Oversteering One Side Widening 5/	F	62.5 ft 18.75 m	57.5 ft 17.25 m	60 ft 18 m	97 ft 29 m	97 ft 29 m	100 ft 30 m

I raccordi planimetrici nelle taxiway (2)

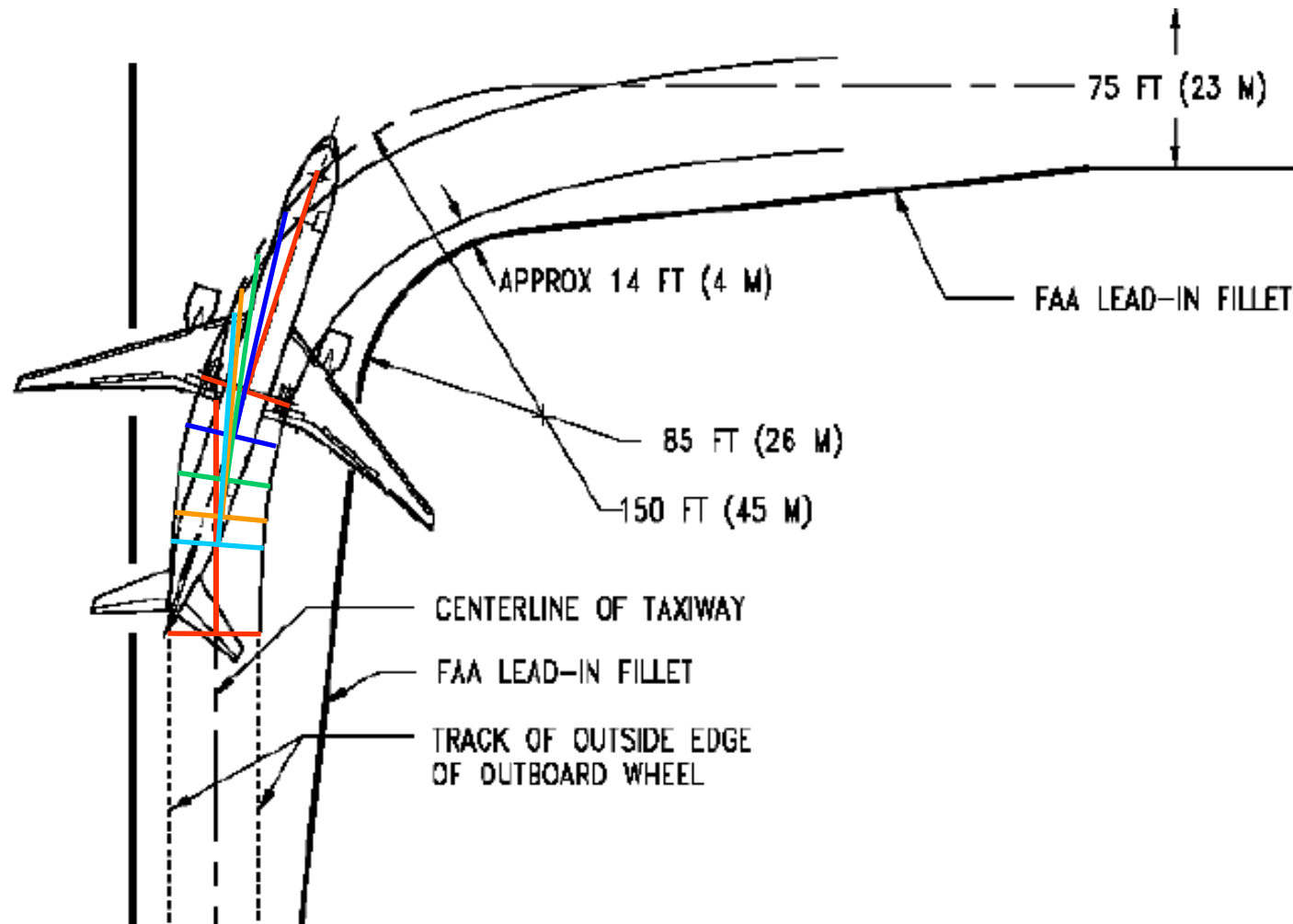

Le bretelle di uscita rapida (1)

Codice numerico	R [m]	V [km/h]
3, 4	550	93
1,2	275	65

$$\frac{V^2}{R} = 127,133 \cdot f_T$$

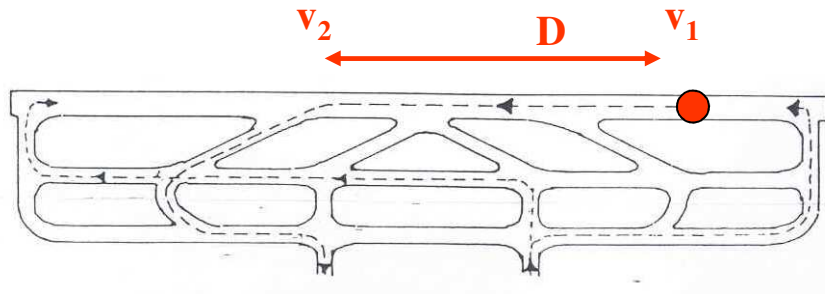
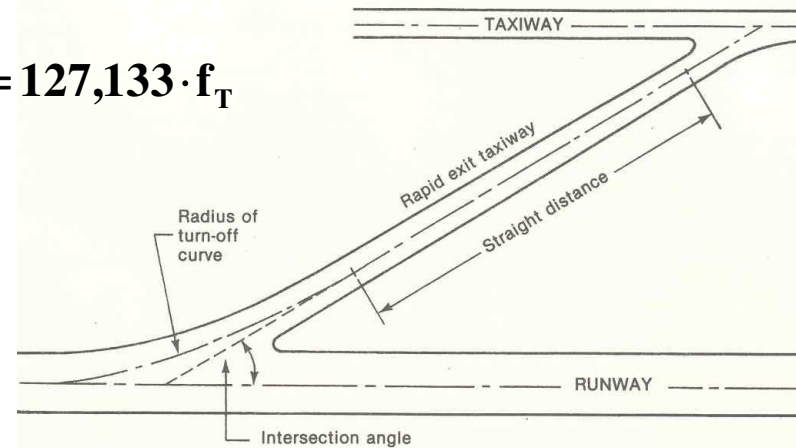

Table 1-11. Accumulated rapid exit usage by distance from threshold (metres)

Aircraft category	50%	60%	70%	80%	90%	95%	100%
A	1 170	1 320	1 440	1 600	1 950	2 200	2 900
B	1 370	1 480	1 590	1 770	2 070	2 300	3 000
C	1 740	1 850	1 970	2 150	2 340	2 670	3 100
D	2 040	2 190	2 290	2 480	2 750	2 950	4 000

$$D = \frac{v_1^2 - v_2^2}{2 \cdot d}$$

$$d = 1,52 \text{ m/s}^2$$

nei rettilinei

$$d = 0,76 \text{ m/s}^2$$

nelle curve

Le bretelle di uscita rapida (2)

Programma REDIM al sito www.atsl.cce.vt.edu/index.htm

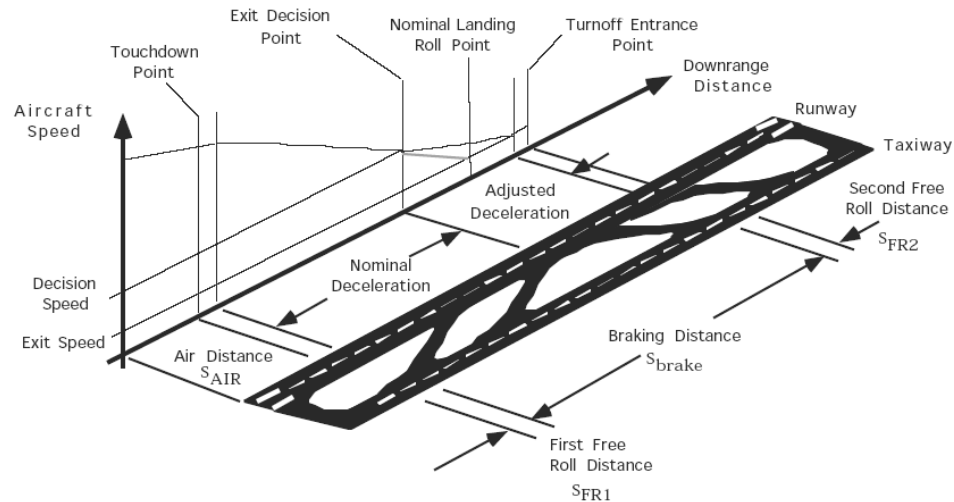
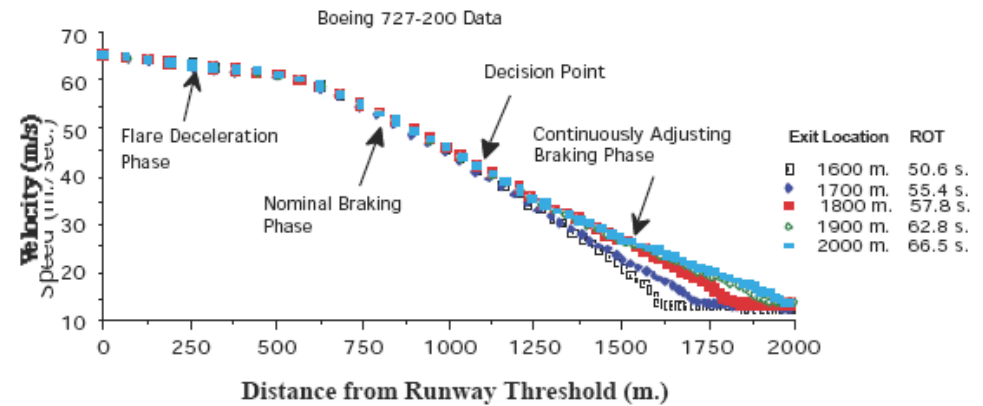

Figure 1.1 Aircraft Landing Segmentation.



Le bretelle di uscita rapida (3)

Codice numerico	R [m]	V [km/h]
3, 4	550	93
1,2	275	65

$$\frac{V^2}{R} = 127,133 \cdot f_T$$

$$D = \frac{v_1^2 - v_2^2}{2 \cdot d} \quad d = 1,52 \text{ m/s}^2$$

$$d = 0,76 \text{ m/s}^2$$

nei rettilinei
nelle curve

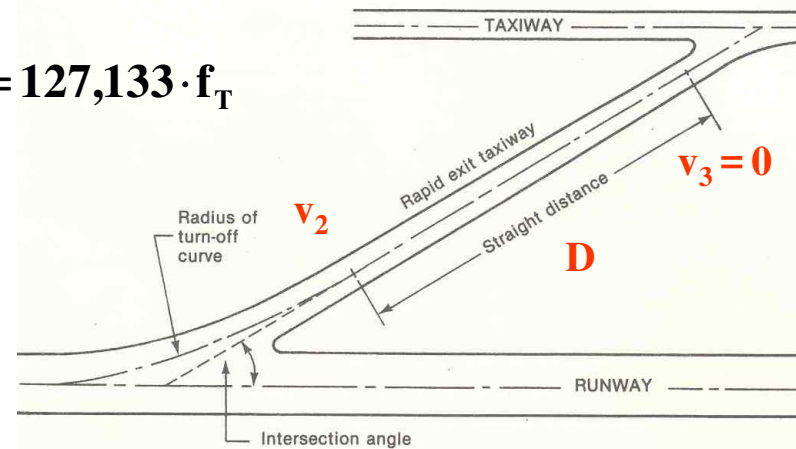

Dmin = 35 m per codici 1,2

Dmin = 75 m per codici 3,4

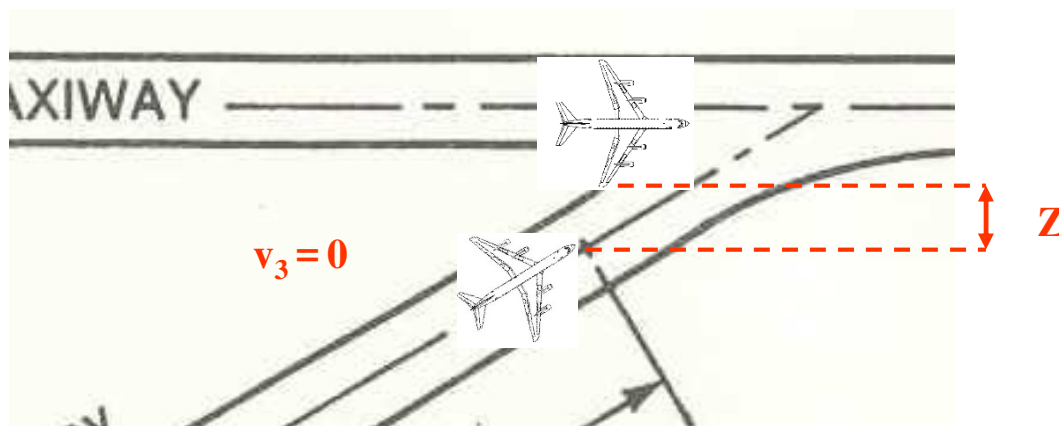

Le bretelle di uscita rapida (4)

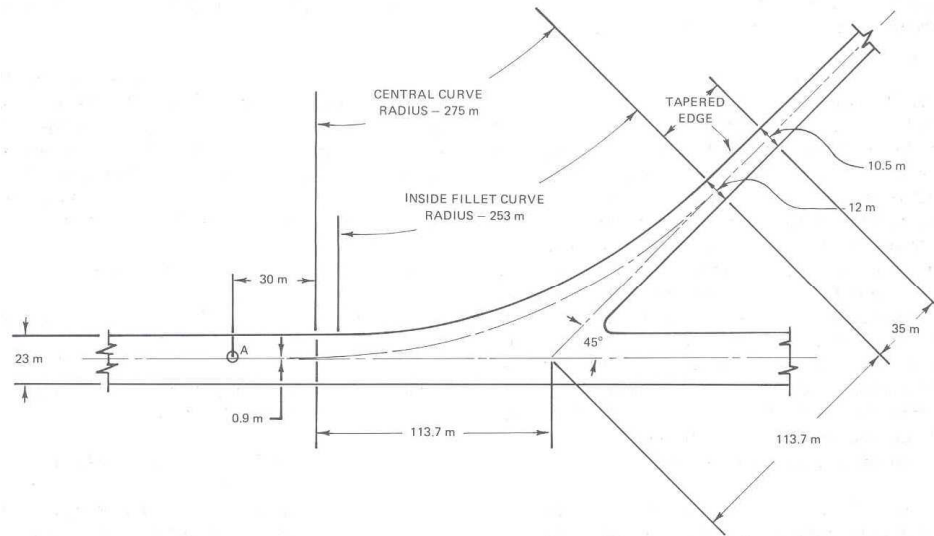

Figure 1-8. Design for rapid exit taxiways (code number 1 or 2)

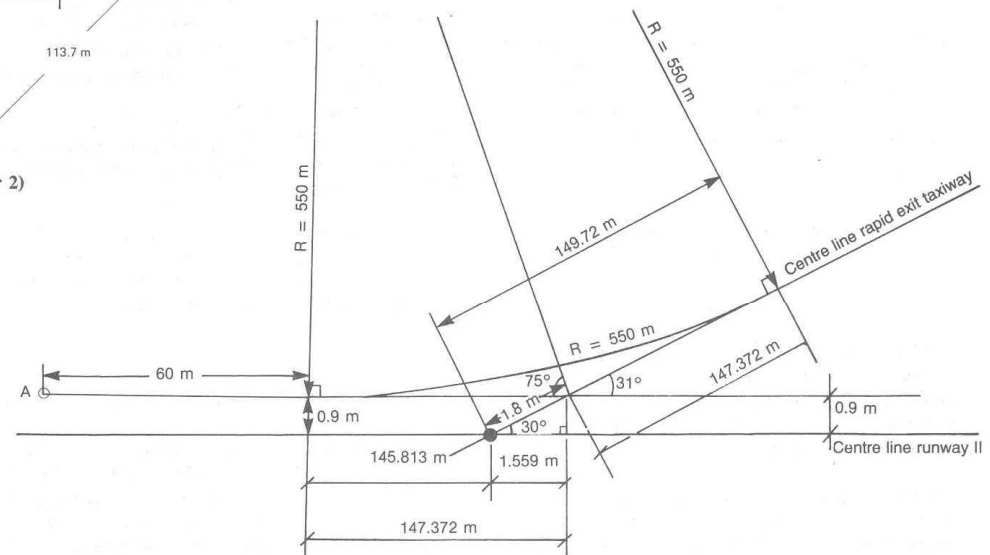
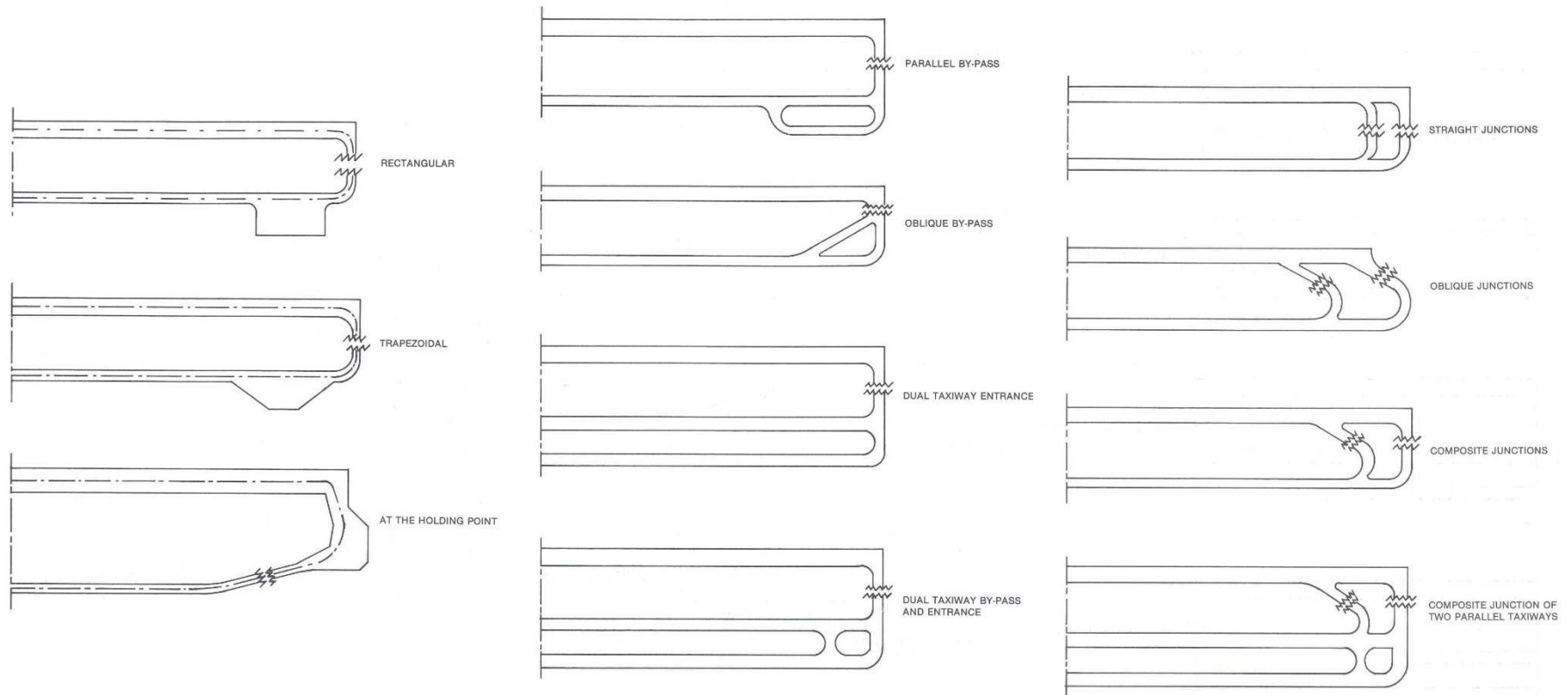

Figure 1-7. Design for rapid exit taxiways (code number 3 or 4)

Le aeree di attesa (1)



Le aeree di attesa (2)

Type of runway	Code number			
	1	2	3	4
Non-instrument	30 m	40 m	75 m	75 m
Non-precision approach	40 m	40 m	75 m	75 m
Precision approach category I	60 m ^b	60 m ^b	90 m ^{a,b}	90 m ^{a,b}
Precision approach categories II and III	–	–	90 m ^{a,b}	90 m ^{a,b}
Take-off runway	30 m	40 m	75 m	75 m

a. If a holding bay, taxi-holding position or road-holding position is at a lower elevation compared to the threshold, the distance may be decreased 5 m for every metre the bay or holding position is lower than the threshold, contingent upon not infringing the inner transitional surface.

b. This distance may need to be increased to avoid interference with radio navigation aids, particularly the glide path and localizer facilities. Information on critical and sensitive areas of ILS and MLS is contained in Annex 10, Volume I, Attachments C and G to Part I, respectively (see also 3.11.5).

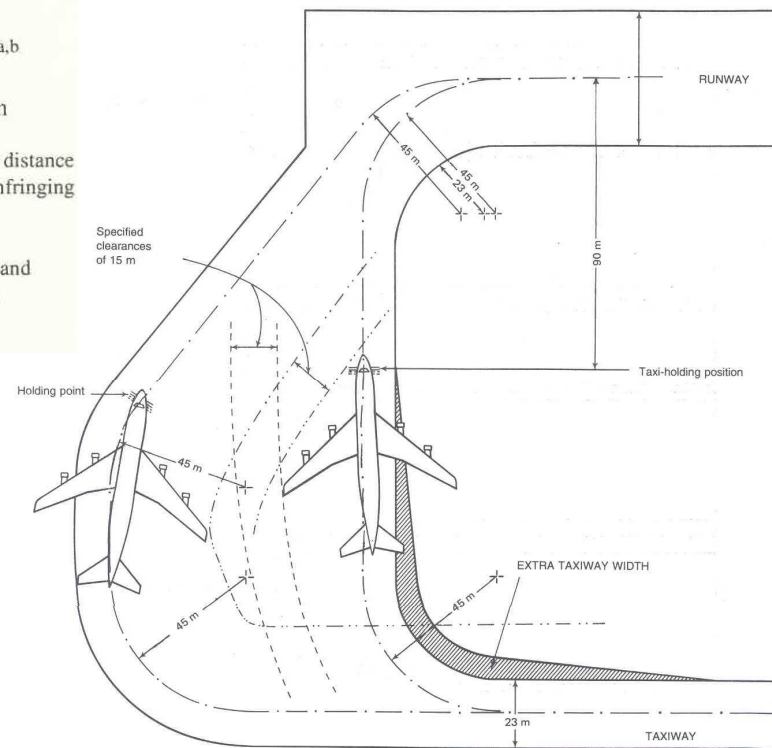

Esercitazione (1)

USO DEI DIAGRAMMI DI PRESTAZIONE PER IL CALCOLO DELLA LUNGHEZZA DI PISTA AL DECOLLO E ALL'ATTERRAGGIO

DATI:

Lunghezza pista: 3000 m

Quota di riferimento dell'aeroporto: 12,5 m s.l.m

Temperatura di riferimento dell'aeroporto: 28,6 ° C

Pendenza longitudinale della pista. Vedi profilo allegato

AEREI	Peso al decollo [kg]	Peso all'atterraggio [kg]	Velocità in soglia [km/h]
MD80	67.000	55.000	250
ATR42	14.500	-	200
BAE 146/300	44.000	38.000	200

DETERMINARE: Lunghezza base sella pista; Classe ICAO dell'aeroporto; verificare il profilo in funzione della classe ICAO; Distanze dichiarate; distanze richieste per ogni aereo; verifica delle uscite per i vari aerei;

Esercitazione (2)

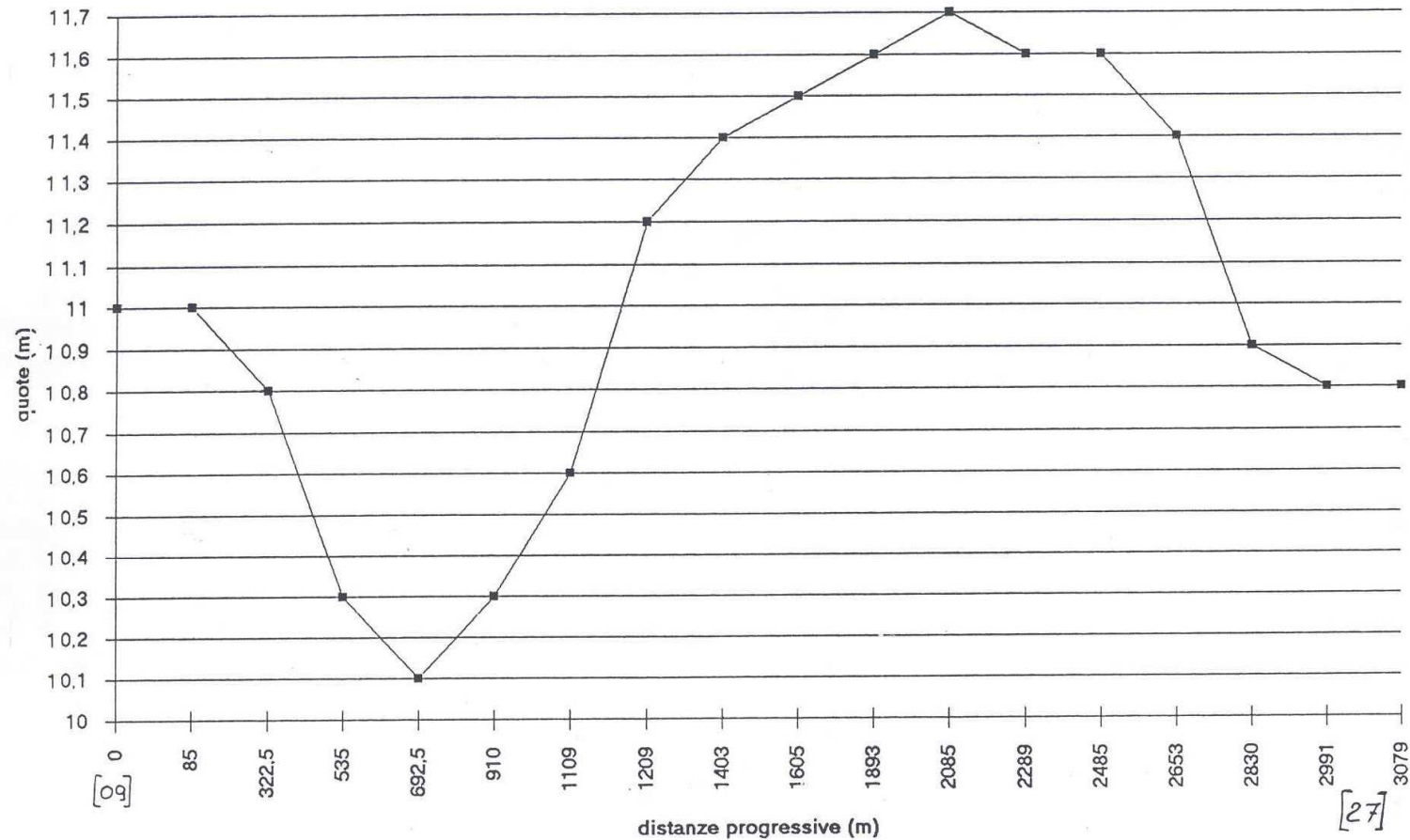

Esercitazione (3)

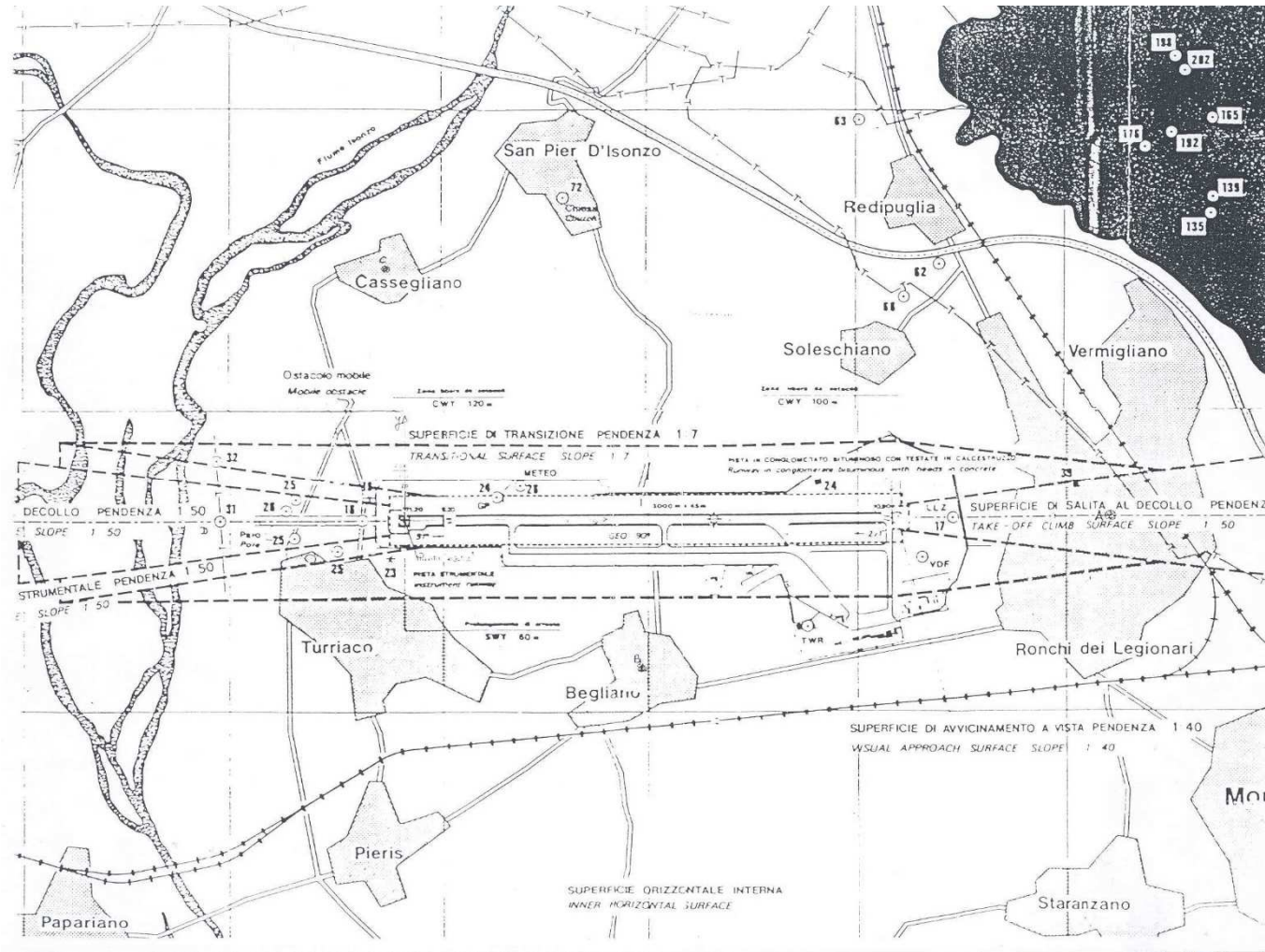

Esercitazione (4)

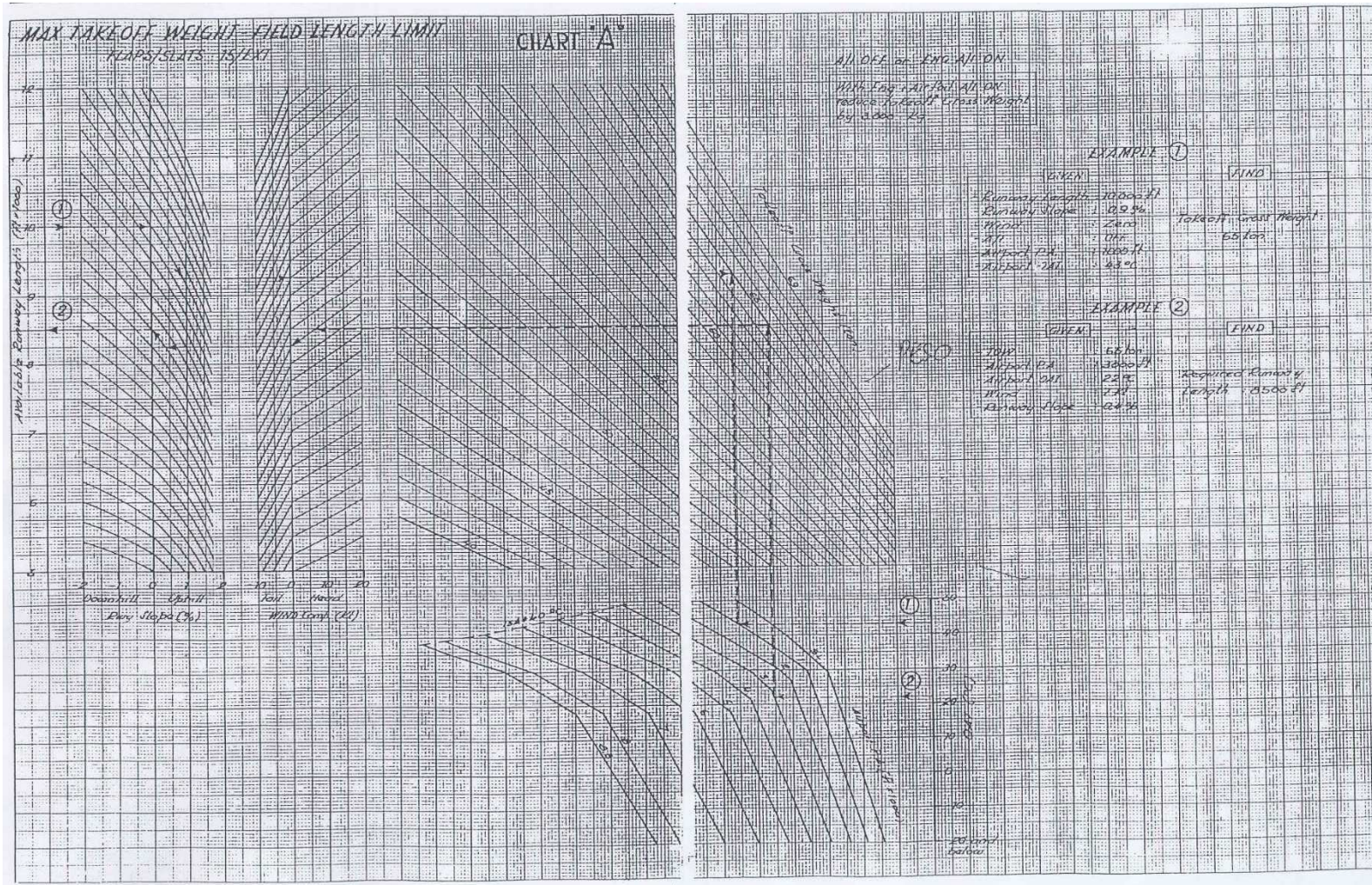

Esercitazione (5)

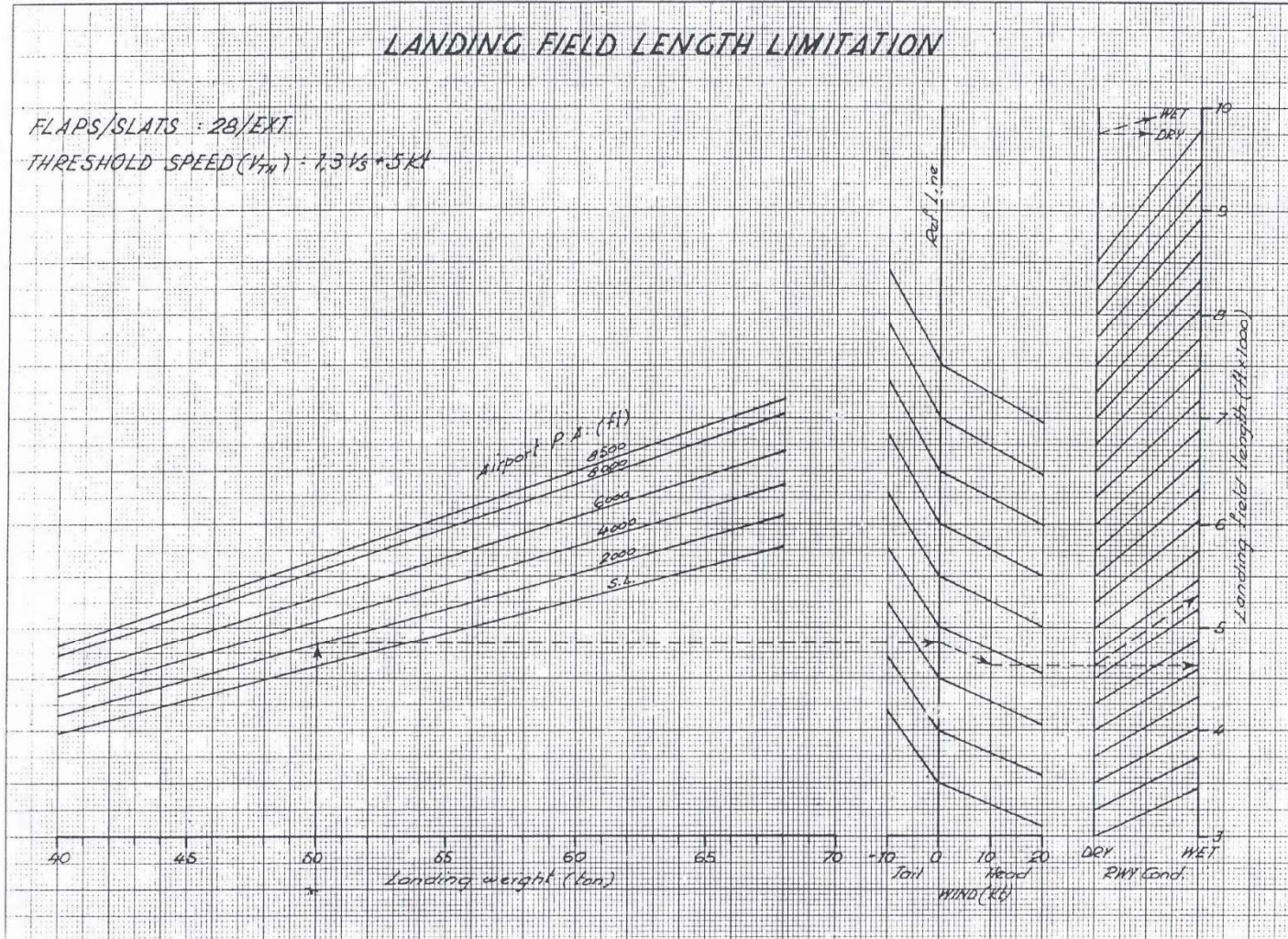

 OPERATIONS MANUAL	DC9/80
Certified Performance LANDING FIELD LENGTH LIMITATION FLAP 28	
II	09-40-03
OCT 83	

Esercitazione (6)

TAKE-OFF PERFORMANCE (SHORT RUNWAY)

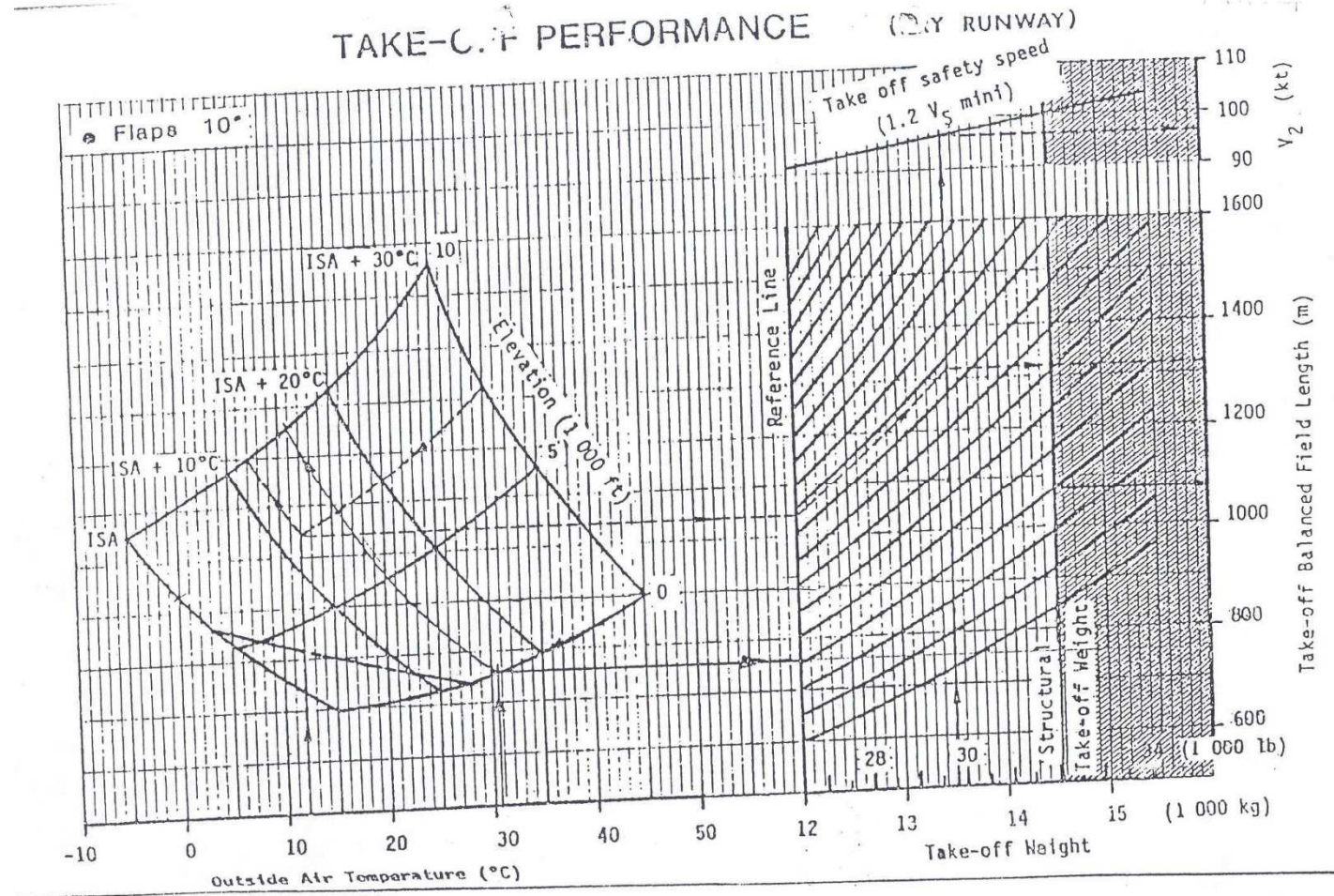

ATR 42

Esercitazione (7)

Design weights, dimensions

Weights, speeds

	146-100		146-200		146-300	
	lb (kg)		lb (kg)		lb (kg)	
Maximum ramp weight	84500 (38329)		93500 (42411)		98000 (44452)	
Maximum take-off weight	84000 (38102)		93000 (42184)		97500 (44225)	
Maximum landing weight	77500 (35153)		81000 (36741)		84500 (38329)	
Maximum zero-fuel weight	66500 (31071)		75000 (34019)		78500 (35607)	
Typical operating weight empty*	51342 (23290)		52651 (23884)		54848 (24891)	
Passenger aircraft						
OT freighter			49185 (22310)		50985 (23126)	
OT convertible (passengers)			57137 (25917)		59343 (26918)	
OT convertible (freight)			52868 (23981)		54498 (24720)	
Design speeds Vmo/Mmo	300 kt IAS/0.73M†		295 kt/0.73M†		305 kt/0.73M†	
Typical cruise speed	425 kt TAS		As -100		As -100	

* Including normal operating items, basic emergency equipment plus crew and their baggage, plus basic galley structure, basic seats and catering when applicable.

† FAR, JAR 0.72M

Payload-range BAe 146 passenger aircraft

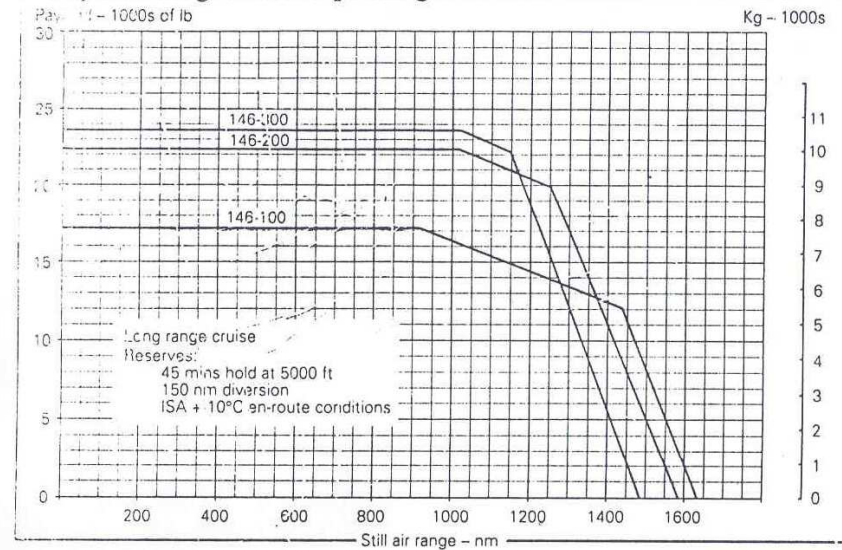

Block fuel

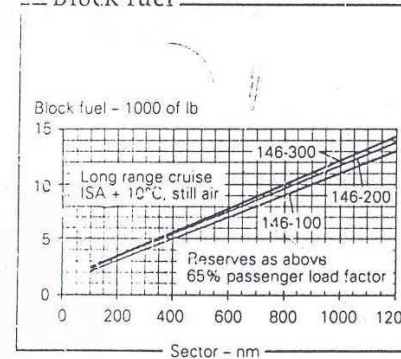

Block time

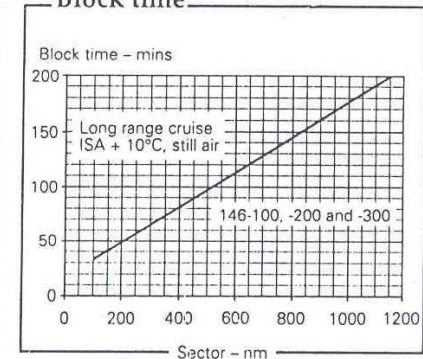

Esercitazione (8)

Design weights, dimensions

	146-100	146-200	146-300
	lb (kg)		
Maximum ramp weight	84500 (38329)	93500 (42411)	99000 (44452)
Maximum take-off weight	84000 (38102)	93000 (42184)	97500 (44225)
Maximum landing weight	77500 (35153)	81000 (36741)	84500 (38329)
Maximum zero-fuel weight	68500 (31071)	75000 (34019)	78500 (35607)
Typical operating weight empty:			79000 (35834) QT
Passenger aircraft	51342 (23290)	52651 (23884)	54848 (24881)
QT freighter		49185 (22310)	50985 (23126)
QT convertible (passengers)		57137 (25917)	59343 (26918)
QT convertible (freight)		52869 (23961)	54498 (24720)
Design speeds V _{mo} /M _{mo}	300 kt IAS/0.73M†	295 kt/0.73M†	305 kt/0.73M†
Typical cruise speed	425 kt TAS	As -100	As -100

* Including normal operating items, basic emergency equipment plus crew and their baggage, plus basic galley structure, basic seats and catering when applicable.

† FAR, JAR 0.72M

Dimensions, capacities

	146-100	146-200	146-300
Wing span	86 ft 5 in (26.34 m)	As -100	As -100
Length	85 ft 11 in (26.19 m)	93 ft 10 in (28.60 m)	101 ft 8 in (30.99 m)
Height	28 ft 3 in (8.61 m)	28 ft 2 in (8.59 m)	As -200
Cabin length	50 ft 7 in (15.42 m)	58 ft 5 in (17.81 m)	66 ft 3 in (20.20 m)
max width	134.5 in (341.6 cm)	As -100	As -100
headroom	80.0 in (203.2 cm)	As -100	As -100
floor width	127.6 in (324.1 cm)	As -100	As -100
Seating	70-94	85-112	90-128
Baggage holds:			
total volume (front and rear)	479 cu ft (13.56 cu m)	645 cu ft (18.26 cu m)	812 cu ft (22.99 cu m)
QT freighter capacity:			
LD3 containers		9	10
108 x 88 pallets/gloos		6 plus half pallet	7 plus half pallet
125 x 96 pallets/gloos		4	5
Fuel capacity:			
Standard	2580 Imp gal (3096 US gal, 11729 litres)		
Optional (inc fillet tanks)	2638 Imp gal (3406 US gal, 12901 litres)		

Engines

Type	Textron Lycoming ALF 502R-5
Take-off thrust (static, sea level, ISA)	6970 lb (31.00 kN)
Overall pressure ratio	12:1
Bypass ratio	5.6:1
Overall length	56.8 in (1.44 m)
Fin case diameter	41.7 in (1.06 m)
Weight, complete engine, dry	1270 lb (577 kg)

Airfield performance

Take-off field length

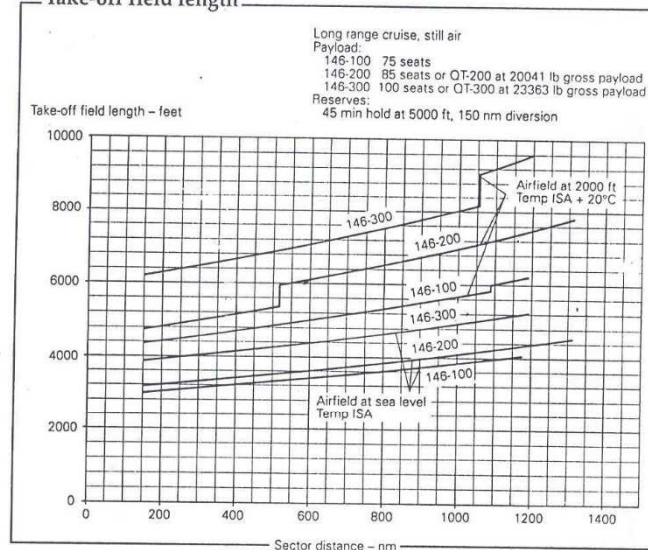

Landing field length

	146-100		146-200		146-300	
	Airfield elevation					
	MSL	2000 ft	MSL	2000 ft	MSL	2000 ft
Dry runway	3380 ft (1030 m)	3535 ft (1077 m)	3510 ft (1070 m)	3660 ft (1116 m)	3740 ft (1140 m)	3880 ft (1183 m)
Wet runway	3887 ft (1185 m)	4065 ft (1239 m)	4037 ft (1230 m)	4209 ft (1283 m)	4301 ft (1311 m)	4462 ft (1360 m)

ISA temperatures, still air, level paved runway
 Landing weight:
 146-100 75 passengers
 146-200 85 passengers or (QT) 20041 lb gross payload
 146-300 100 passengers or (QT) 23363 lb gross payload
 Fuel for 45 min hold at 5000 ft and 150 nm diversion

Performance to JAR (Method A) and FAR certification requirements