



Università degli Studi di Trieste

Dipartimento di Ingegneria e Architettura

Laurea Magistrale: Ingegneria Civile

Corso di INFRASTRUTTURE AEROPORTUALI

Lezione 06: L'aerea terminale

Roberto Roberti

Tel.: 040/558.3588

E-mail: roberto.roberti@dia.units.it

Anno accademico 2016/2017



Argomenti

Tipologie di terminal

Determinazione numero stalli

Configurazioni e dimensioni degli stalli

Funzioni terminal

Determinazione dei fabbisogni del terminal

Le problematiche dell'area terminale

- Capacità, adeguata alla domanda **TERMINAL**
- Distanze pedonali limitate
- Ambiente piacevole e comodo
- Servizi disponibili e vicini
- Sicurezza

**PIAZZALI
(APRON)**



ACCESSI

Tipologie dei terminal

DISTRIBUZIONE ORIZZONTALE:

- **Lineare**
- **Moli**
- **Satellite**
- **Piazzale aperto (Transporter)**

DISTRIBUZIONE VERTICALE

- **Piano singolo**
- **Un piano e mezzo**
- **Due piani**

Terminal lineare centralizzato

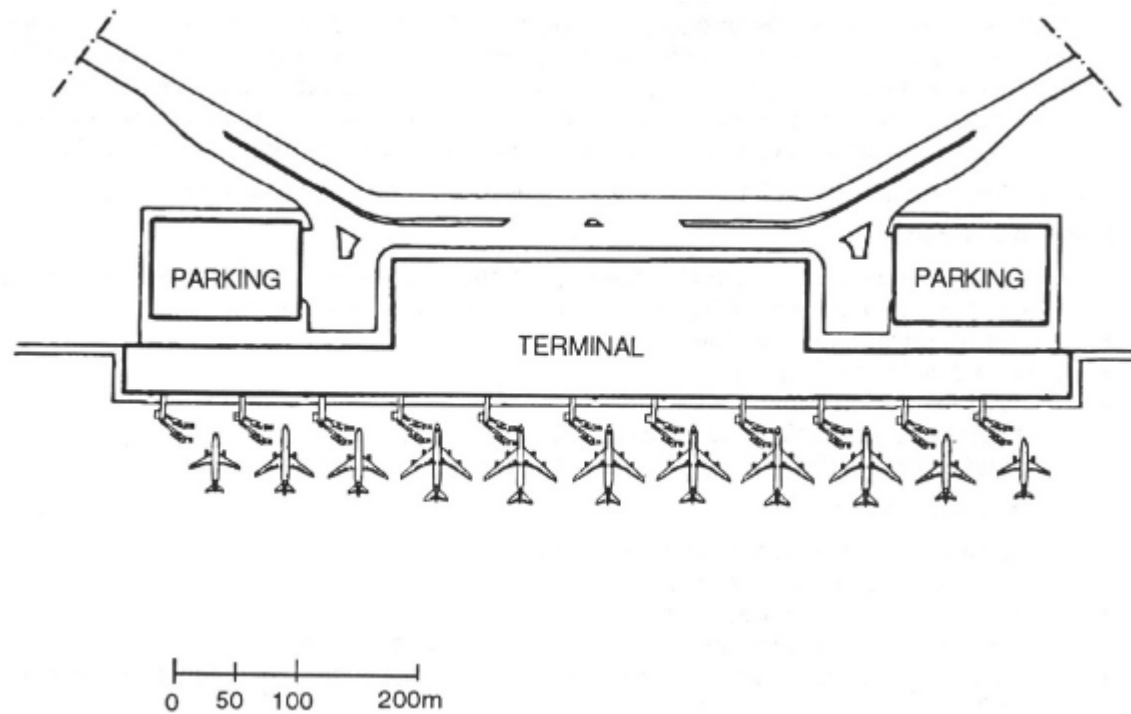

Terminal lineare centralizzato

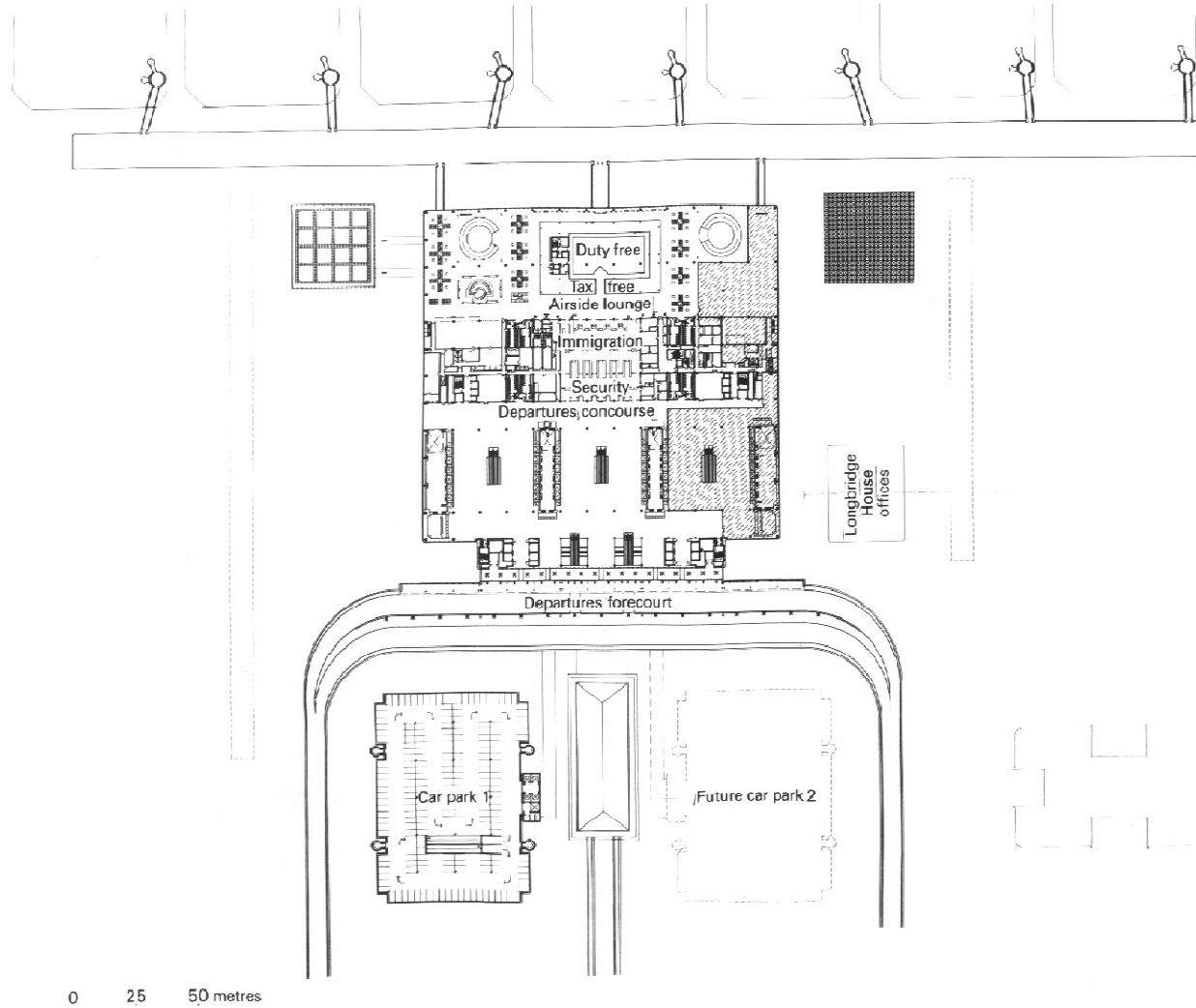

Terminal lineare semi-centralizzato

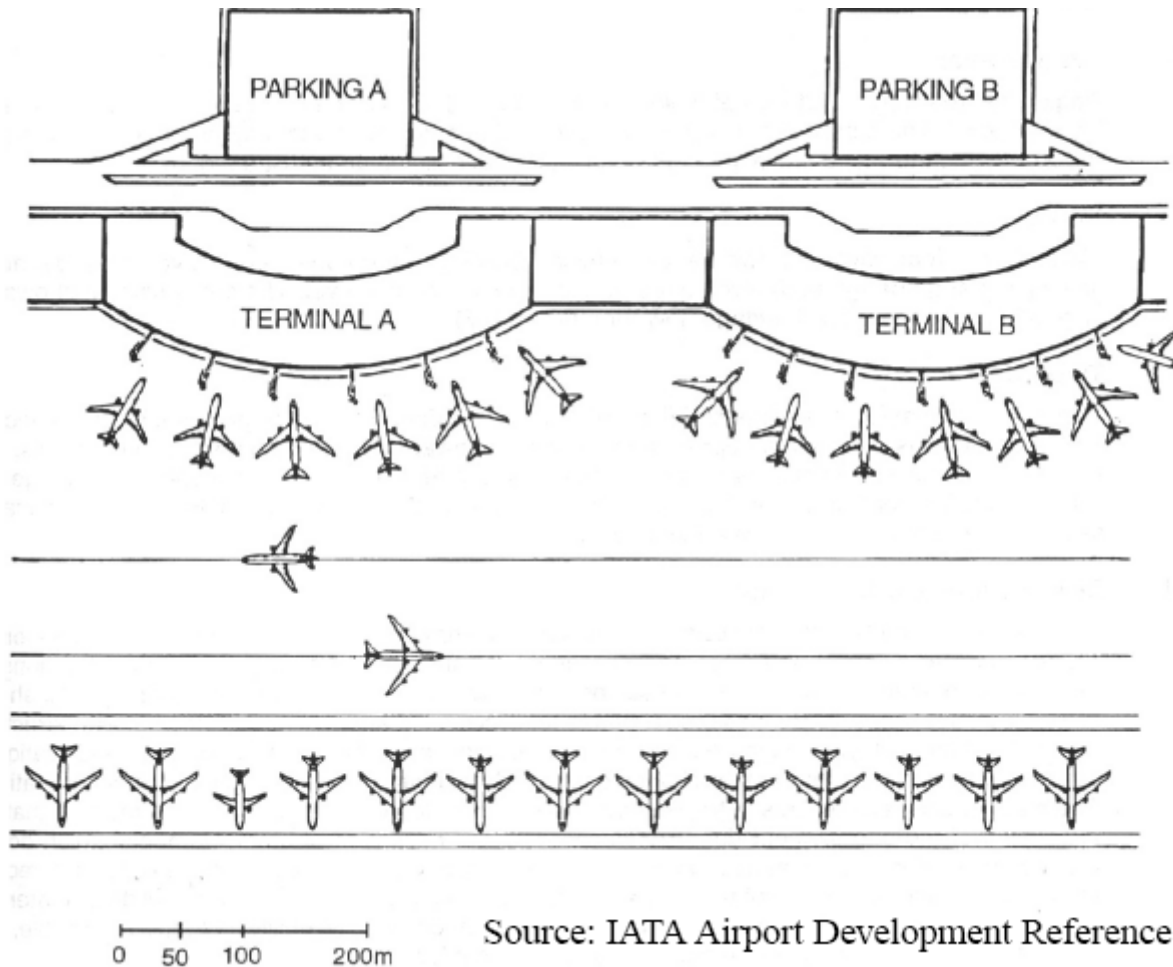

Terminal centralizzato con moli (1)

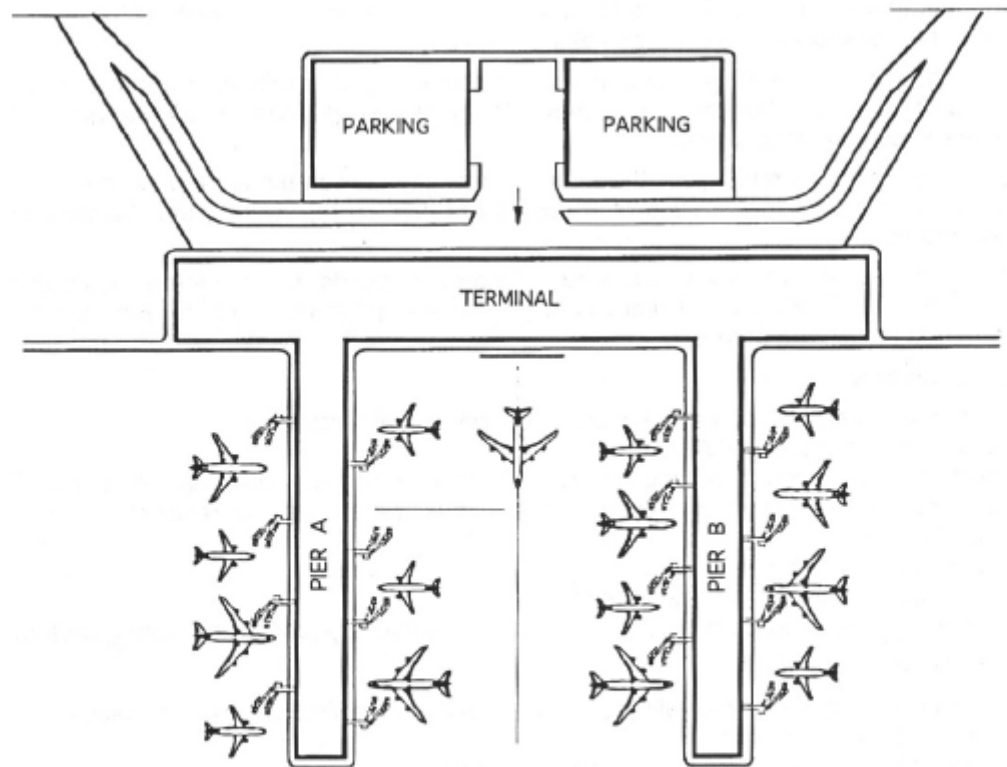

0 50 100 200m

Source: IATA Airport Development Reference Manual

Terminal centralizzato con moli (2)

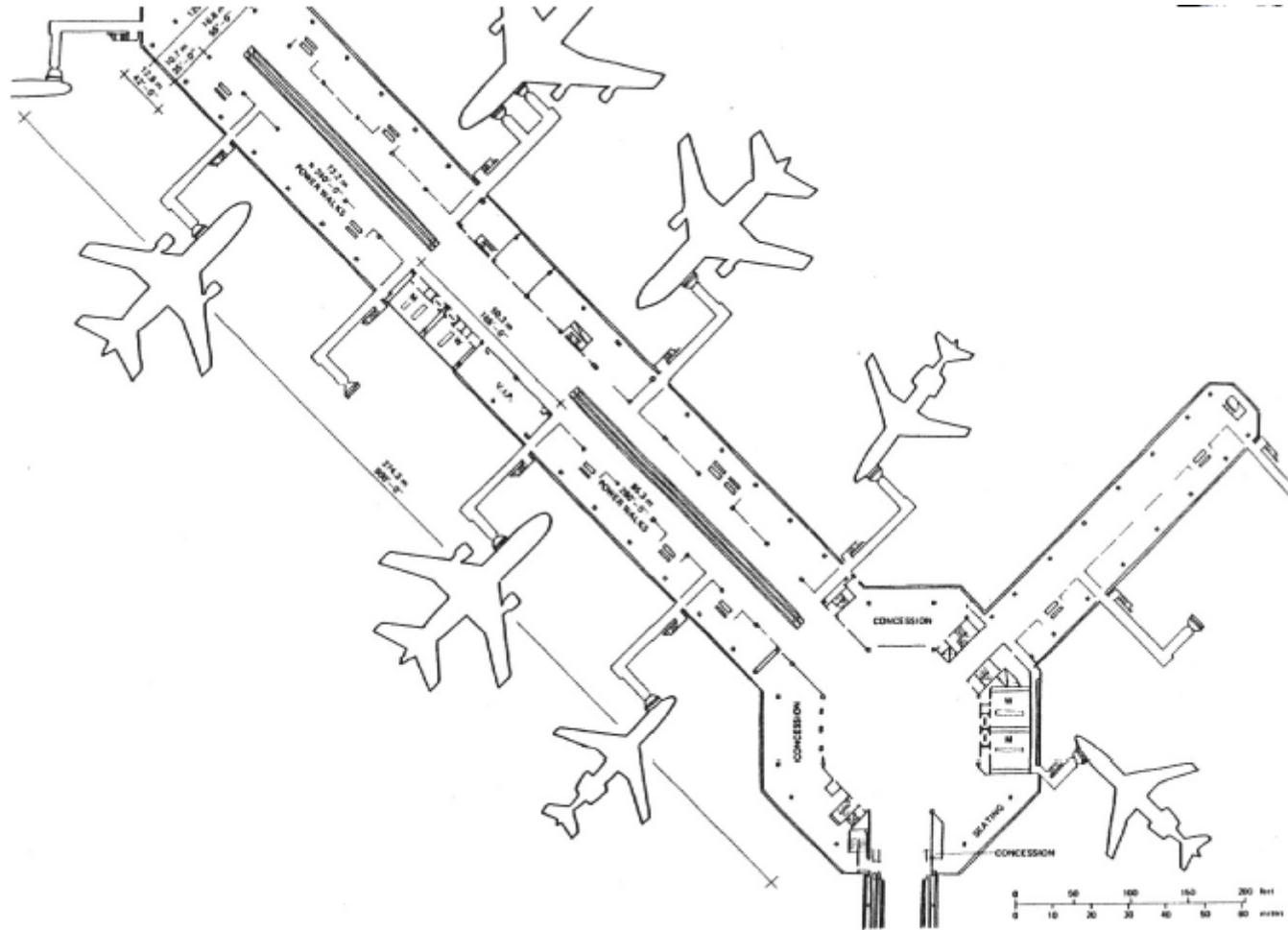

Terminal a satellite (1)

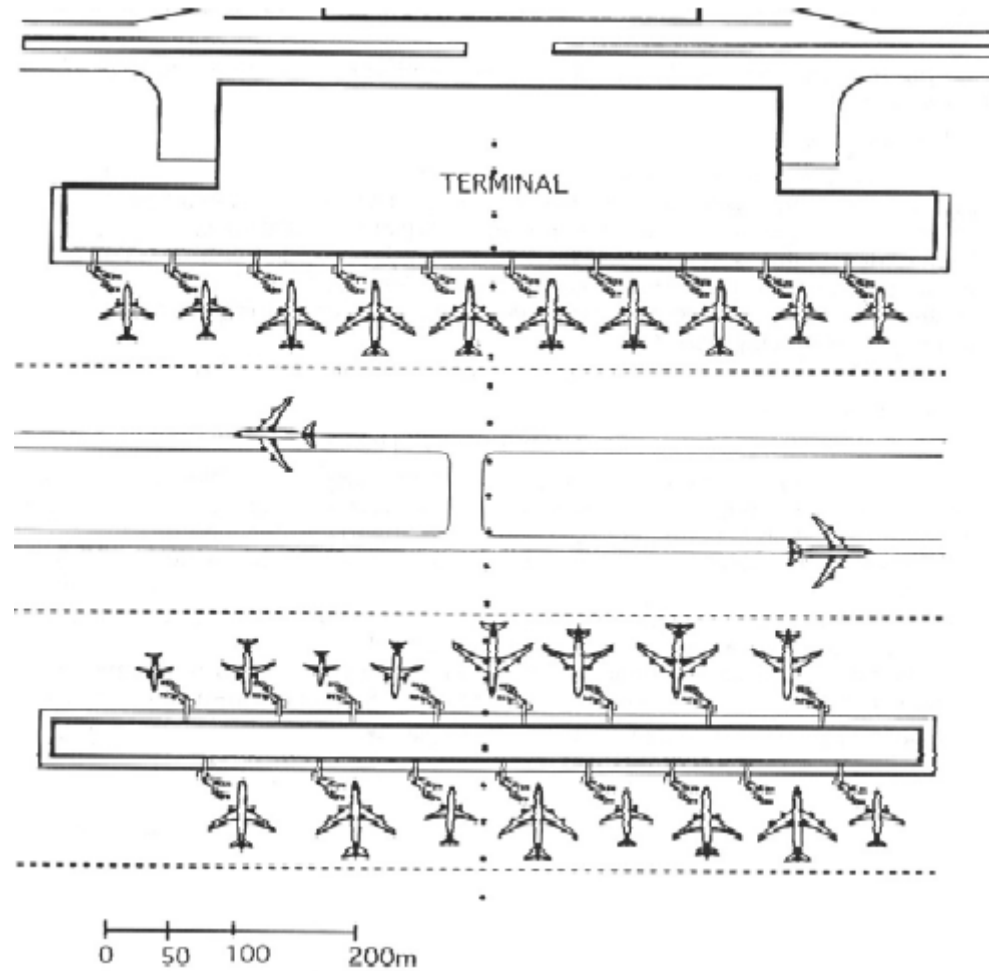

Terminal a satellite (2)

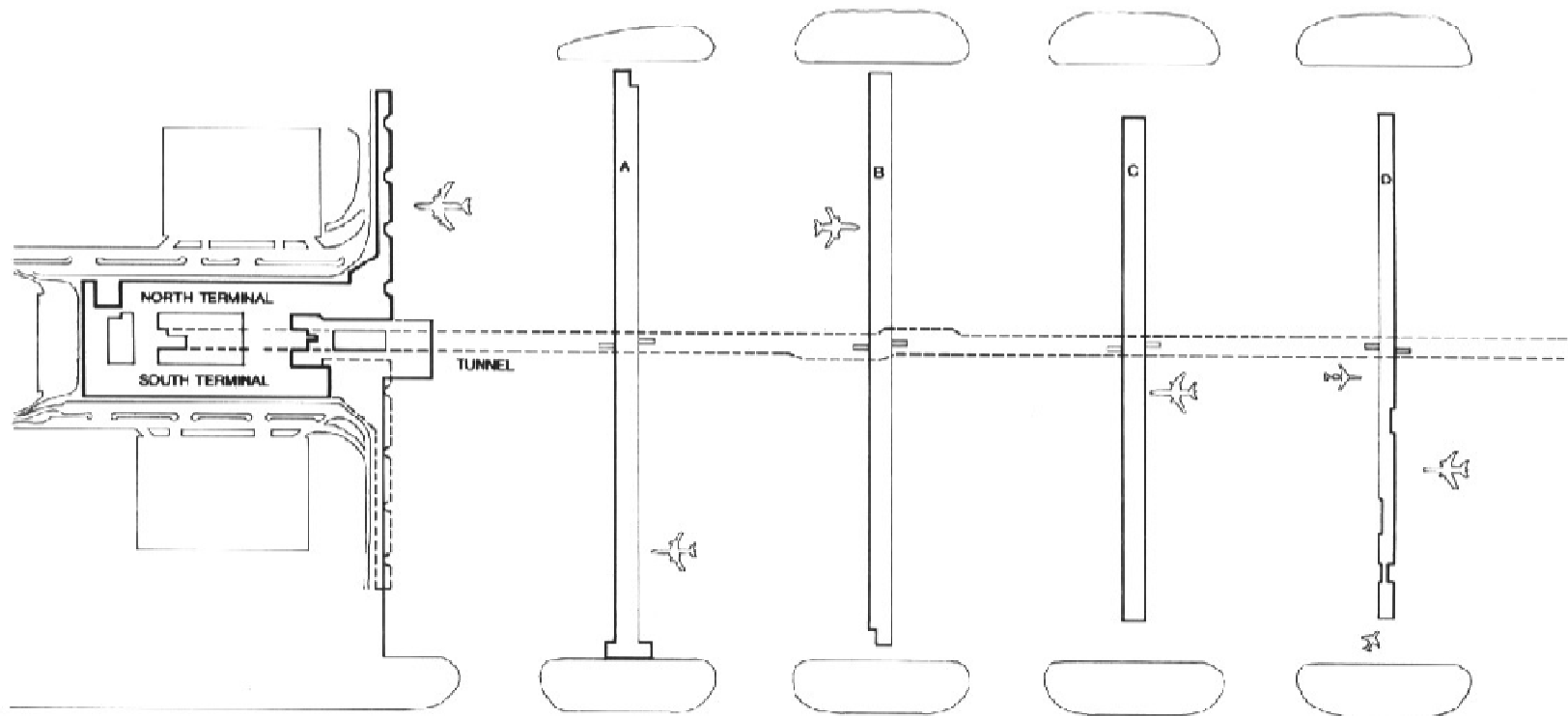

Transporter con terminal centrale

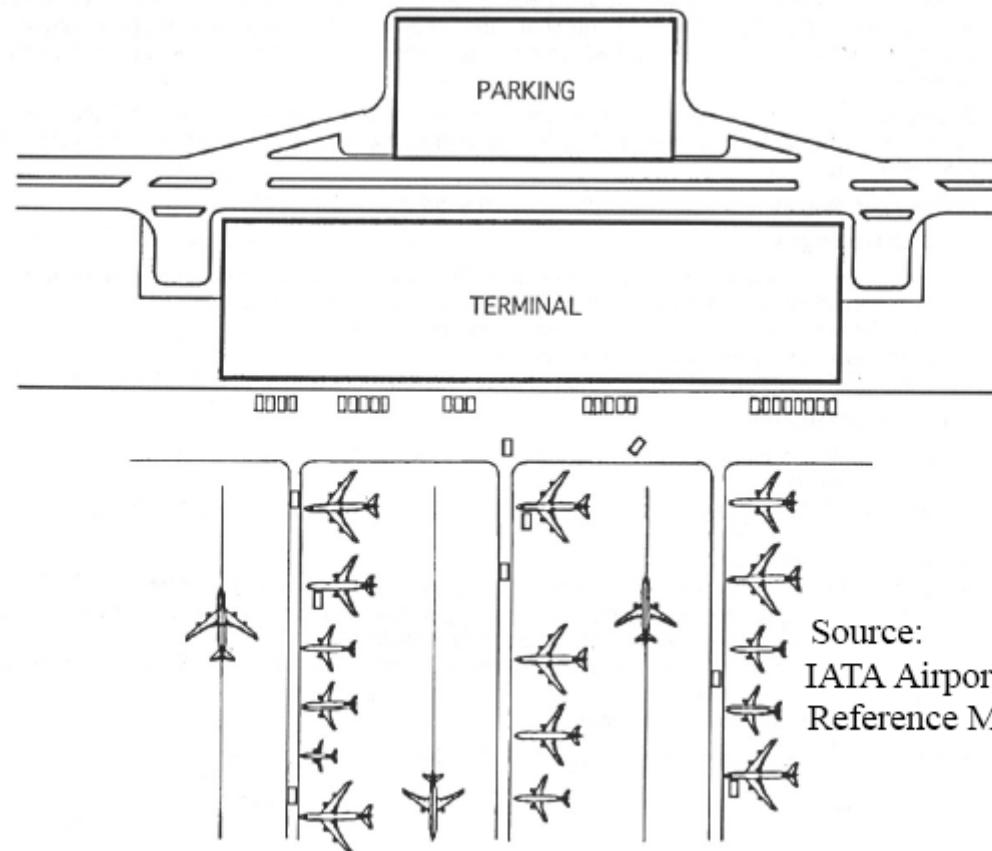

Source:
IATA Airport Development
Reference Manual

Terminal ad un piano

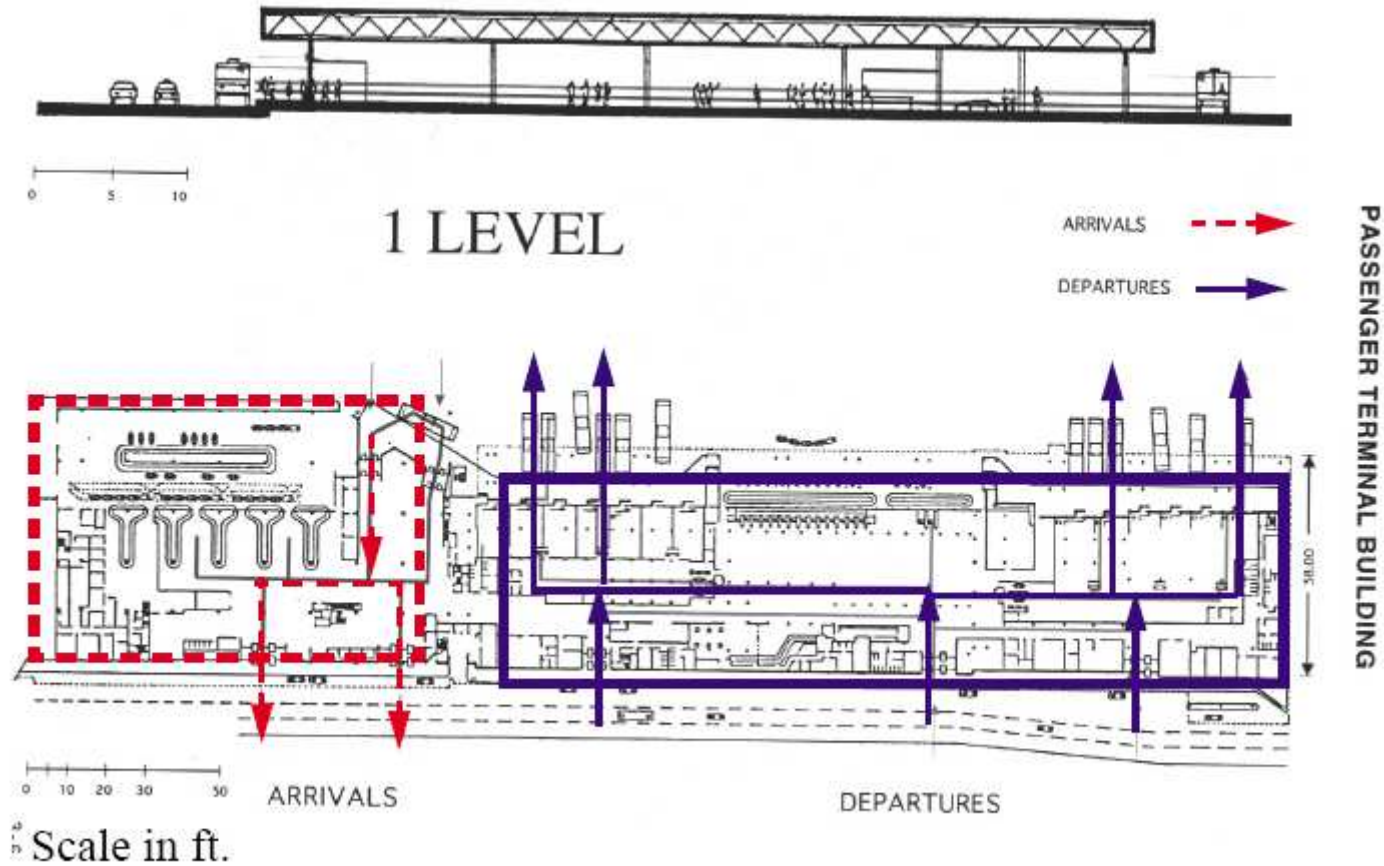

Source: IATA Airport Development Reference Manual

Terminal ad un piano e mezzo

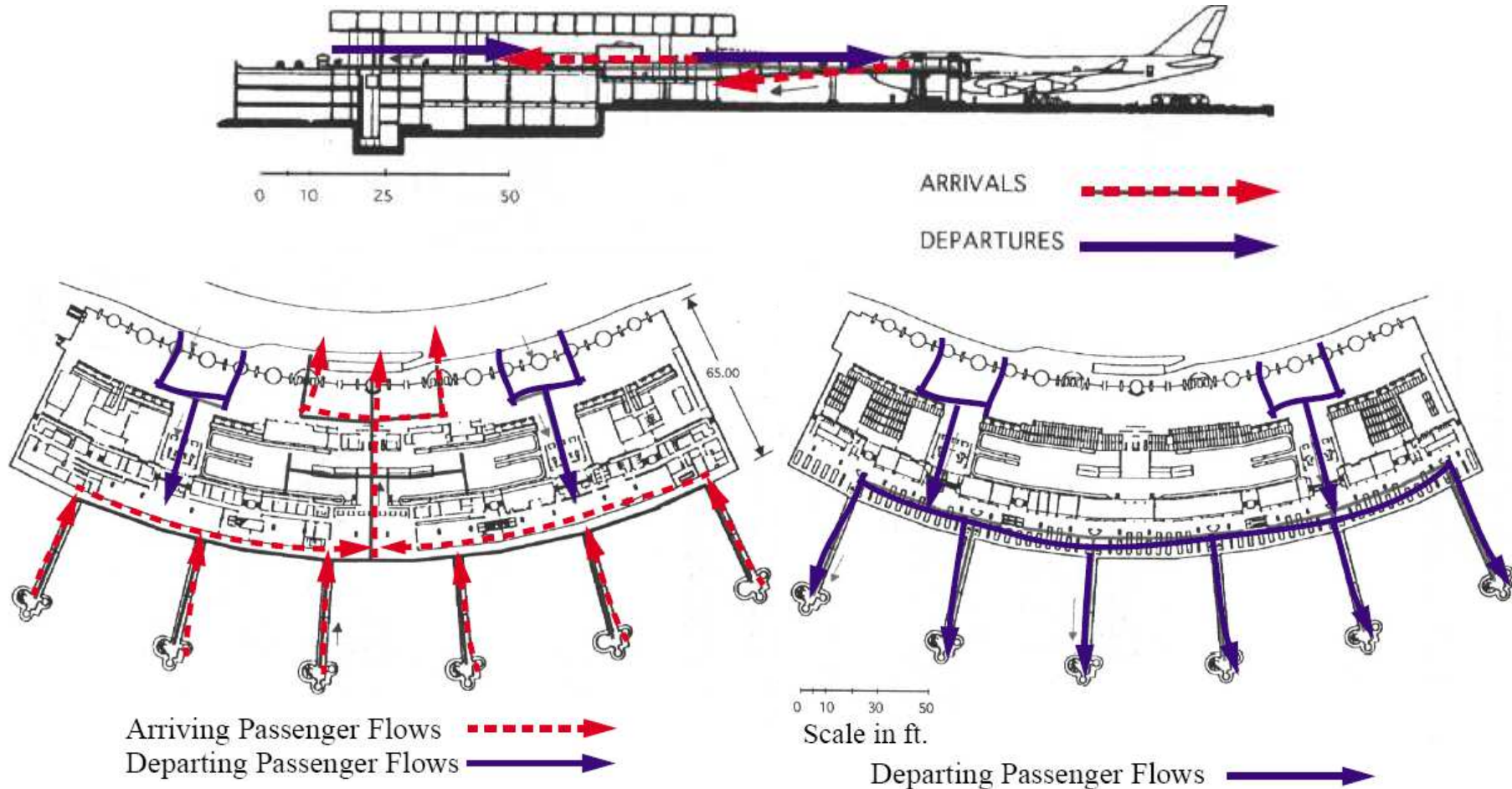

Terminal a due piani



0 10 25 50

Scale in ft.

ARRIVALS ———
DEPARTURES ———

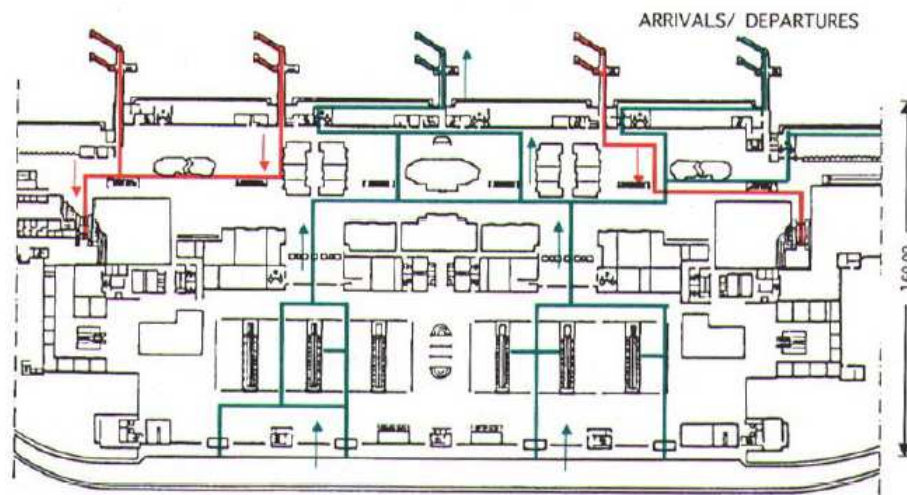

0 20 50

Departing Passenger Flows ———→
Arriving Passenger Flows ———→

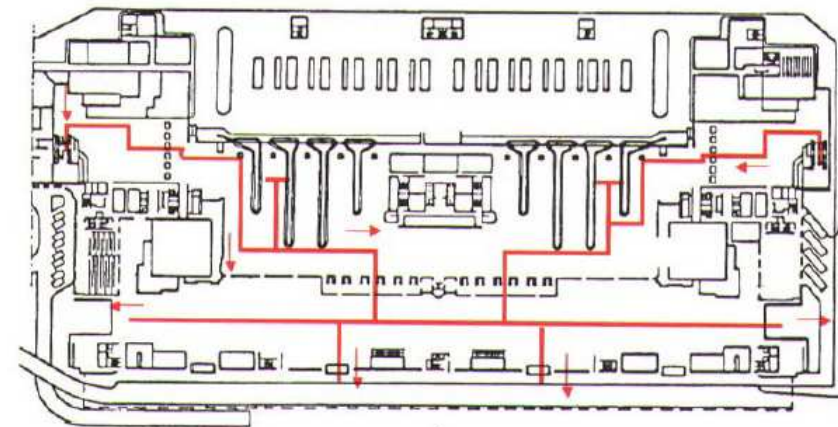

0 20 50

ARRIVALS
Arriving Passenger Flows ———→

Numero di Stalli

$$N = \left(\sum_i m_i \cdot \frac{T_i}{60 \cdot u} \right) \cdot C + \alpha$$

u = fattore di utilizzazione (0 – 1)

N = numero stalli necessari

m_i = % di aerei del gruppo i che opera sull'aeroporto

T_i = tempo di servizio del gate per l'aereo di tipo i

C = domanda richiesta all'aeroporto (Aerei/ora)

α = riserva

Aircraft	Domestic		International Turnaround flight	Group	Aircraft
	Through flight	Turnaround flight			
B-737, DC-9, F-28	25	45	—	S	F-28, B-737
B-707, B-757	45	50	60	M	B-707-320, A-300, L-1011, DC-10
A300, DC-10, L-1011	45-60	60	120	L	B-747 SP, B-747
B-747	—	60	120-180	LL	B-747 II (future aircraft)

Handling

Servizi di handling:

- Le prestazioni rese ai passeggeri (biglietteria, accettazione, informazioni, etc.),
- Le prestazioni inerenti i velivoli (carico e scarico, pulizie, rifornimenti, guida al parcheggio, etc.),
- Le prestazioni inerenti le merci (carico e scarico, stoccaggio, documentazione, etc.).

Servizi di Rampa (1)

- guida dell'aereo all'arrivo o alla partenza negli spostamenti sull'apron;
- assistenza al parcheggio del velivolo;
- assistenza passeggeri in partenza, in arrivo o in transito;
- assistenza bagagli, merci, posta, carico e scarico aereo;
- trasporto dell'equipaggio;
- pulizie di bordo;
- climatizzazione della cabina;
- rimozione neve o ghiaccio e sbrinamento del velivolo;
- assistenza all'avviamento del velivolo;
- rifornimento del velivolo di carburante e acqua potabile;
- servizi di catering;
- eventuale manutenzione del velivolo.

Servizi di Rampa (2)



Servizi di Rampa (3)



Servizi di Rampa (3)

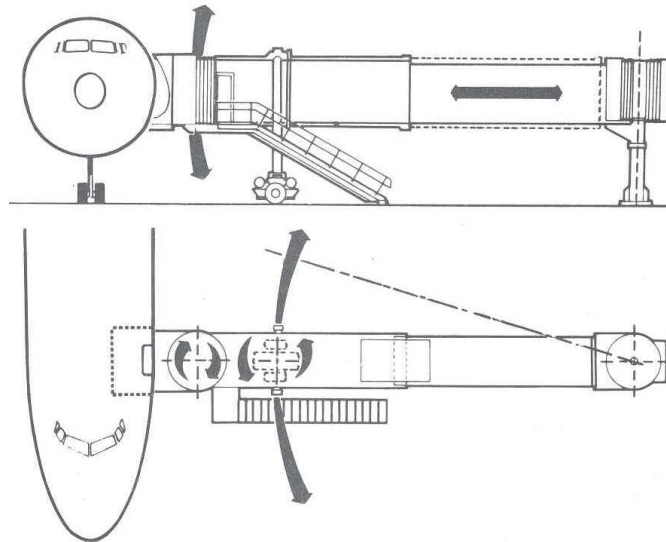
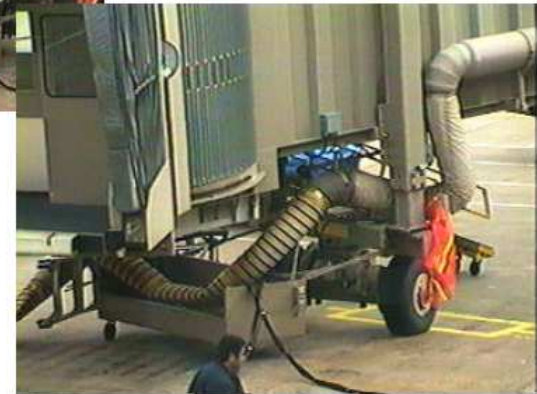

Servizi di Rampa (4)



Servizi di Rampa (5)

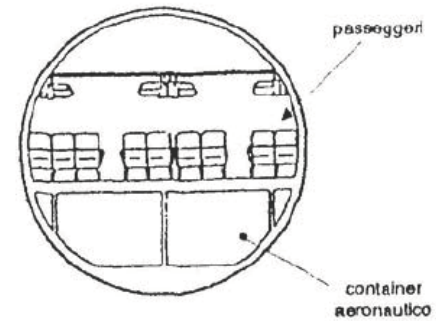

a) PASSEGGERI E MERCI

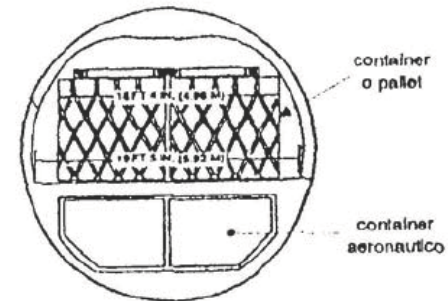

b) SOLO MERCI

Servizi di Rampa (6)



Servizi di Rampa (7)



Servizi di Rampa (8)

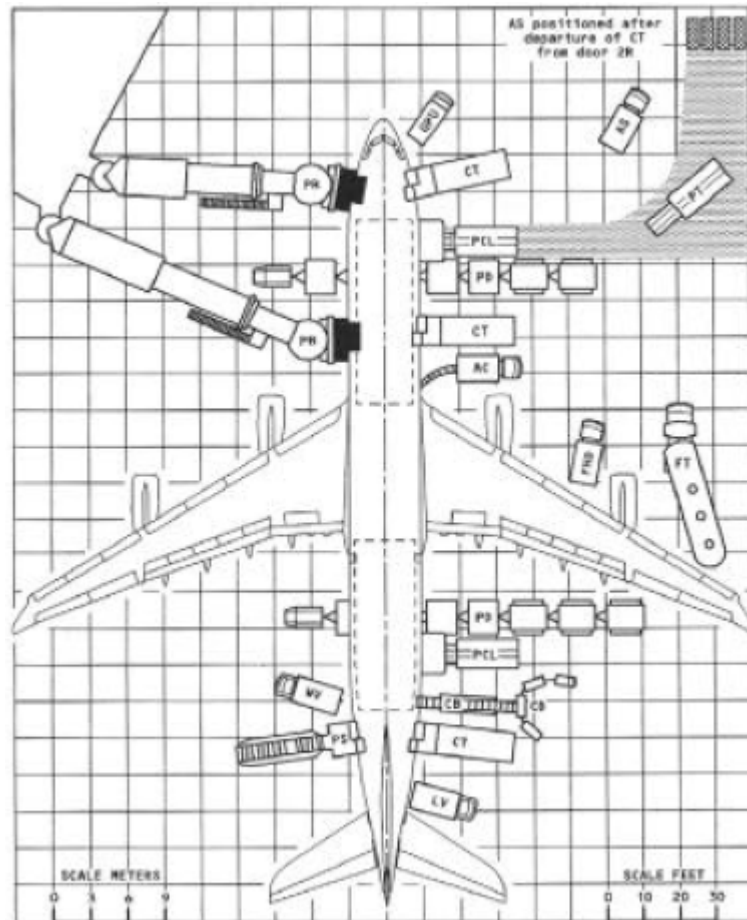

- A Air Conditioning
- B Bulk Cargo Door
- C Cargo Container Door
- E(2) Electrical (2 Connections)
- F(2) Fuel (2 Connections)
- H Hydraulic Connection
- H₂O Potable Water
- L Lavatory
- MLG Main Landing Gear
- NG Nose Gear
- O Oxygen
- P(2) Pneumatic Air Start (2 Connections)
- U Upper Deck Exit Door
- X Main Deck Passenger Door
- V Fuel Vent

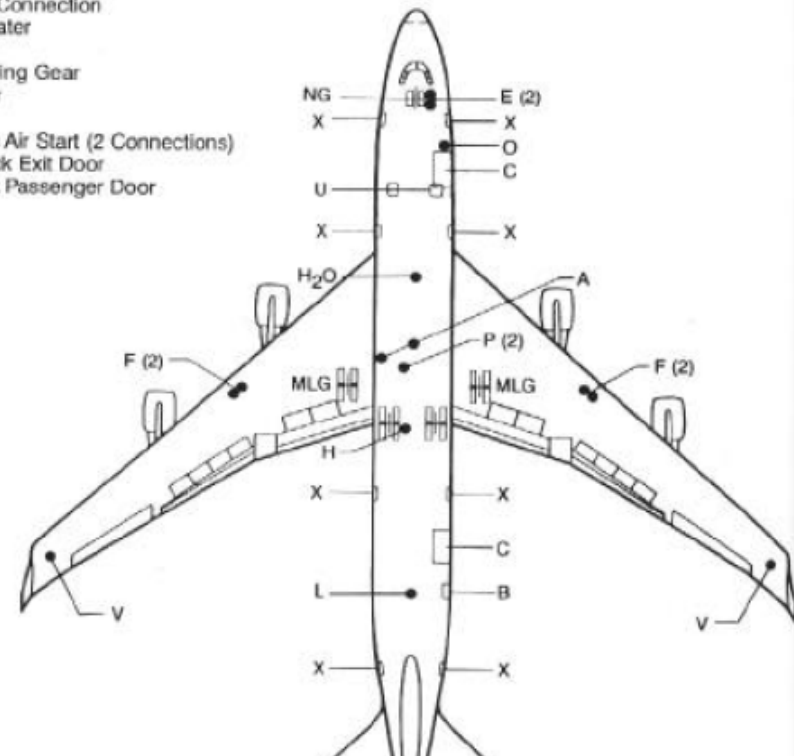

Servizi di Rampa (9)

TABLE OF AIRCRAFT GROUND HANDLING EQUIPMENT

TYPE OF EQUIPMENT	IATA AHM NUMBER	LENGTH (m)	WIDTH (m)	AREA (m)	HEIGHT (m)	TURNING RADIUS (m)
MAIN DECK LOADER	932	12.0	4.5	54.0	3.0	20.0
LOWER DECK LOADER	931	8.5	3.5	29.7	2.9	12.0
TRANSPORTER	969	6.5	3.5	22.8	1.5	5.5
AIRCRAFT TOW TRACTOR (WIDE BODY)		9.0	2.8	25.2	2.0	7.5
AIRCRAFT TOW TRACTOR (NARROW BODY)		5.5	2.5	13.7	2.3	5.5
PALLET DOLLEY - SIDE LOADING (END TOWING)	966	4.5	2.6	11.7	3.0	5.5
PALLET DOLLEY - END LOADING (SIDE TOWING)	966	3.8	3.4	14.4	3.0	5.5
6m ULD DOLLY	967	8.0	2.6	20.8	3.5	8.0
CONTAINER DOLLY	965	4.0	1.8	7.2	2.2	4.5
BAGGAGE CART	963	3.5	1.5	5.3	2.0	6.0
BELT CONVEYOR	925	7.5	2.0	15.0	1.0	7.6
PASSENGER STAIRS (WIDE BODY)	920	10.0	2.5	25.0	4.0	12.2
CATERING TRUCK (WIDE BODY)	927	9.0	2.5	22.5	4.0	12.2
AIR CONDITIONING UNIT		6.5	2.5	16.3	2.5	6.5
LAVATORY VEHICLE	971	6.5	2.5	16.3	2.2	6.5
POTABLE WATER VEHICLE	970	6.5	2.5	16.3	2.2	8.0
ULD TRANSPORT SEMI-TRAILER (4 PALLET)	960	16.0	2.5	40.0	4.0	9.0
TUGS (RAMP TRACTORS)	968	2.5	1.3	6.5	1.7	2.5

The IATA Ramp Services and Equipment Group has developed the above table of dimensions for typical aircraft ground handling equipment for use in producing the layout of airport terminal aprons. Numerous models of each type of ground handling equipment are produced by many manufacturers in at least a dozen countries. The dimensions provided should be considered as typical of each type of equipment and should be used as a "rule of thumb" for general airport planning purposes.

Ingombri statici e dinamici (1)

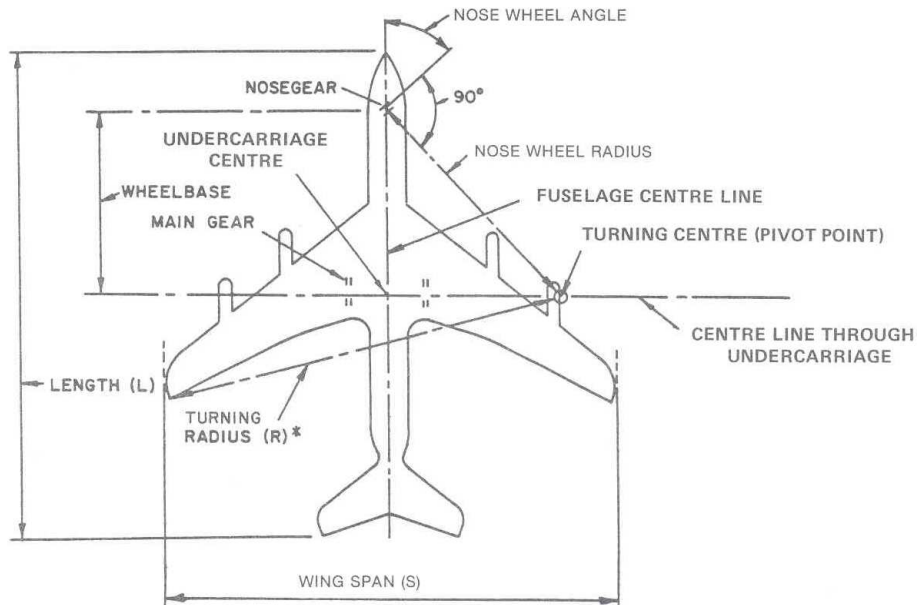

Aircraft type	Length (m)	Wing span (m)	Nose wheel angle	Turning radius (m)
A300B-B2	46.70	44.80	50°	38.80 ^a
B727-100	40.59	32.92	75°	21.90 ^c
B727-200	46.68	32.92	75°	25.00 ^c
B737-100	28.65	28.35	70°	18.40 ^a
B737-200	30.58	28.35	70°	18.70 ^a
B747	70.40	59.64	60°	60.20 ^a
B747-400	70.67	64.90		
B757	47.32	37.95	60°	27.90 ^a
B767	48.51	47.63	60°	36.00 ^a
BAC 111-400	28.50	27.00	65°	21.30 ^a
Caravelle	36.70	34.30	45°	29.00 ^a
Concorde	62.10	25.50	50°	30.10 ^c
DC8-40/50	45.95	43.41	70°	29.20 ^a
DC8-61/63	57.12	43.41/45.2	70°	32.70 ^c
DC9-10/20	31.82	27.25/28.5	75°	17.80 ^c
DC9-30	36.36	28.44	75°	20.40 ^c
DC9-40	38.28	28.44	75°	21.40 ^c
DC9-50	40.72	28.45	75°	22.50 ^c
DC9-80	45.02	32.85	75°	25.10 ^b
DC10-10	55.55	47.35	65°	35.60 ^a
DC10-30	55.35	50.39	65°	37.30 ^a
DC10-40	55.54	50.39	65°	36.00 ^a
L1011	54.15	47.34	60°	35.59 ^a
Vickers Viscount 800	26.10	28.60	50°	21.60 ^a

a To wing tip
b To nose
c To tail

Ingombri statici e dinamici (2)

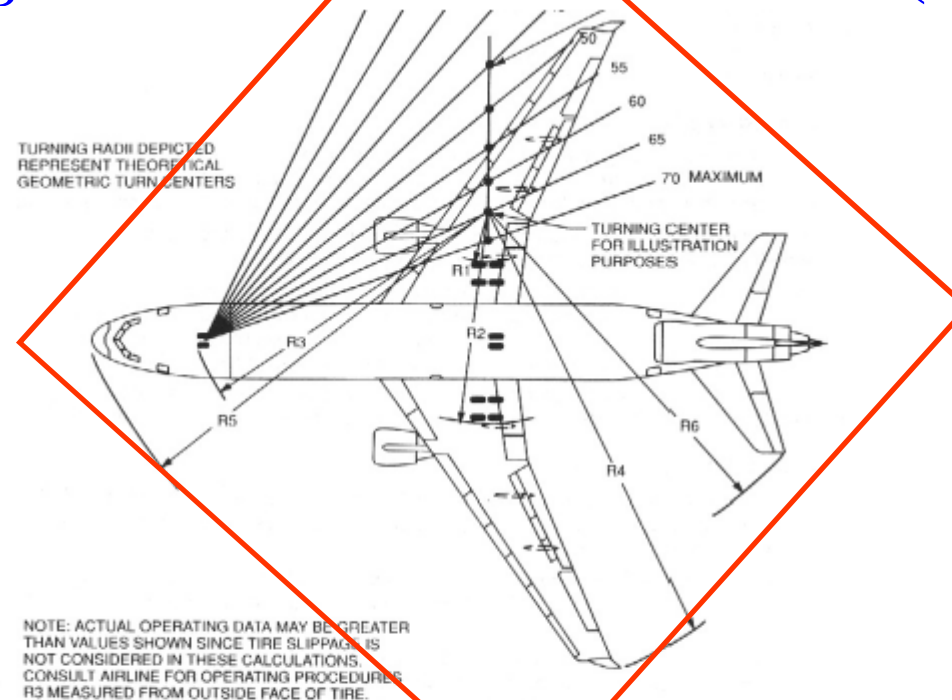

STEERING ANGLE (DEG)	R-1		R-2		R-3		R-4		R-5		R-6	
	FT	m	FT	m	FT	m	FT	m	FT	m	FT	m
25	153.7	48.8	194.9	59.4	194.0	59.1	202.8	60.0	205.7	62.7	220.2	67.1
30	120.2	36.6	161.4	49.2	164.3	50.1	229.5	69.9	178.2	54.3	189.5	57.8
35	95.5	29.1	136.7	41.7	143.5	43.7	205.2	62.5	159.4	48.6	167.7	51.2
40	76.3	23.2	117.5	35.8	120.2	39.1	186.4	56.8	145.9	44.5	151.3	46.1
45	60.7	18.5	101.9	31.1	116.6	35.6	171.2	52.2	136.1	41.5	138.5	42.2
50	47.6	14.5	88.8	27.1	107.8	32.9	158.5	48.3	128.7	39.2	128.9	39.1
55	36.3	11.1	77.5	23.6	100.9	30.8	147.6	45.0	123.1	37.5	119.9	36.6
60	26.3	8.0	67.6	20.6	95.6	29.1	138.0	42.0	118.8	36.2	112.9	34.4
65	17.3	5.3	58.5	17.8	91.4	27.9	129.4	39.4	115.6	35.2	107.0	32.6

Configurazione dei parcheggi (1)

a) Taxi-in/taxi-out
(angled nose-in parking)

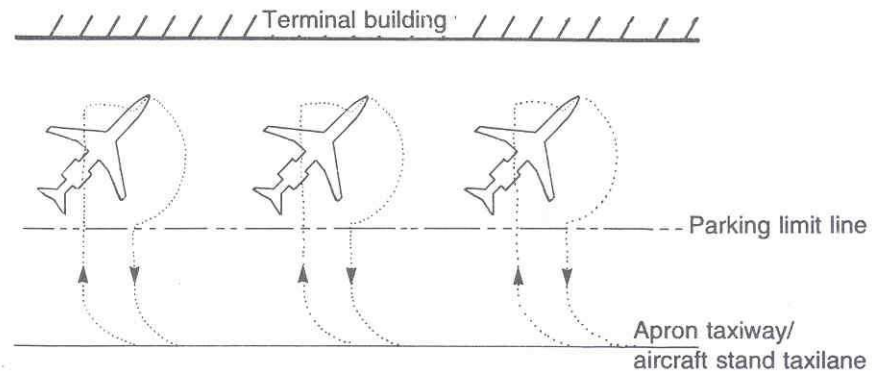

b) Taxi-in/taxi-out
(angled nose-out parking)

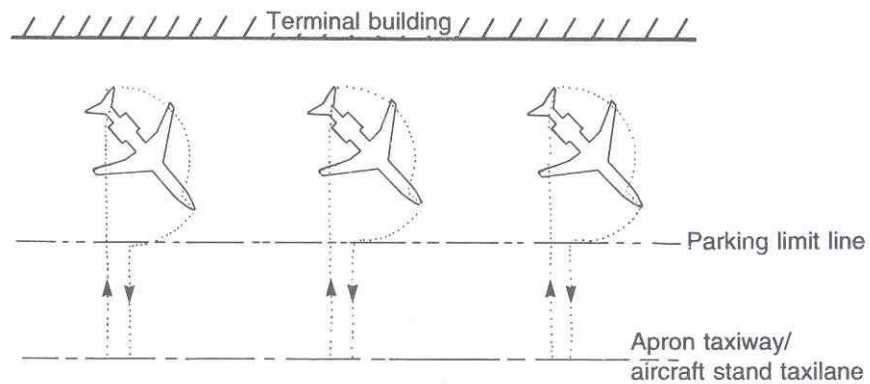

Configurazione dei parcheggi (2)

c) Taxi-in/taxi-out
(parallel parking)

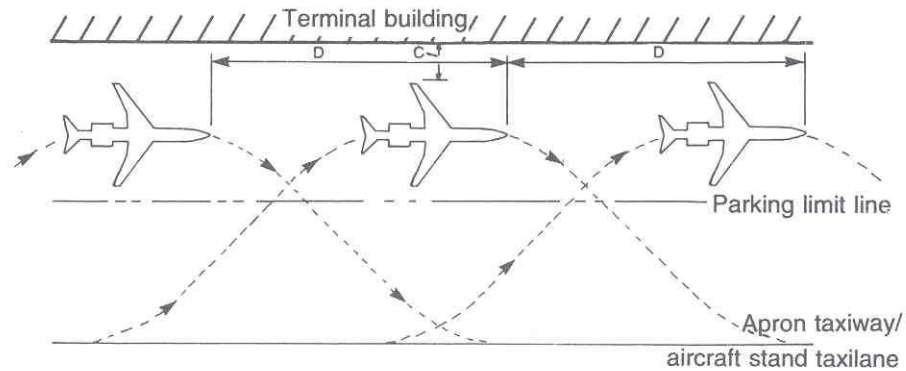

d) Taxi-in/push-out

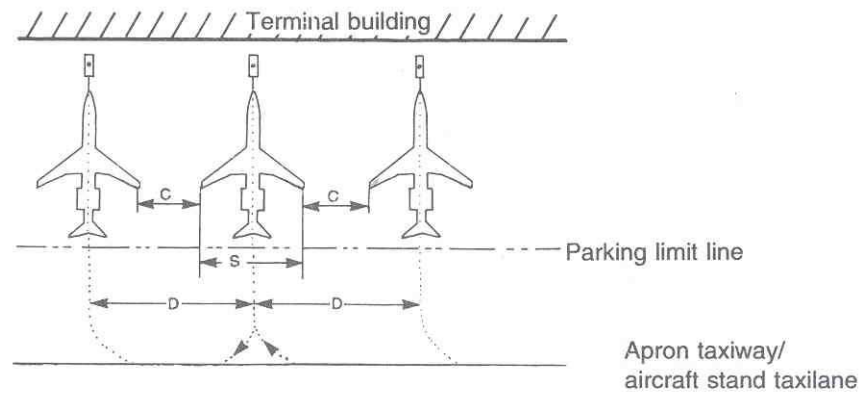

Dimensioni degli stalli e manovre (1)



EFFECTIVE TURN ANGLE	X	Y	A	R3	R4	R5	R6
63° 64	1.35	33.11	122.26	69.71	109.27	89.29	111.15
	18.70	10.09	37.26	21.25	33.31	27.21	33.68

ed i diagrammi dei minimi spazi richiesti:
(ad es. per il AB 300)-

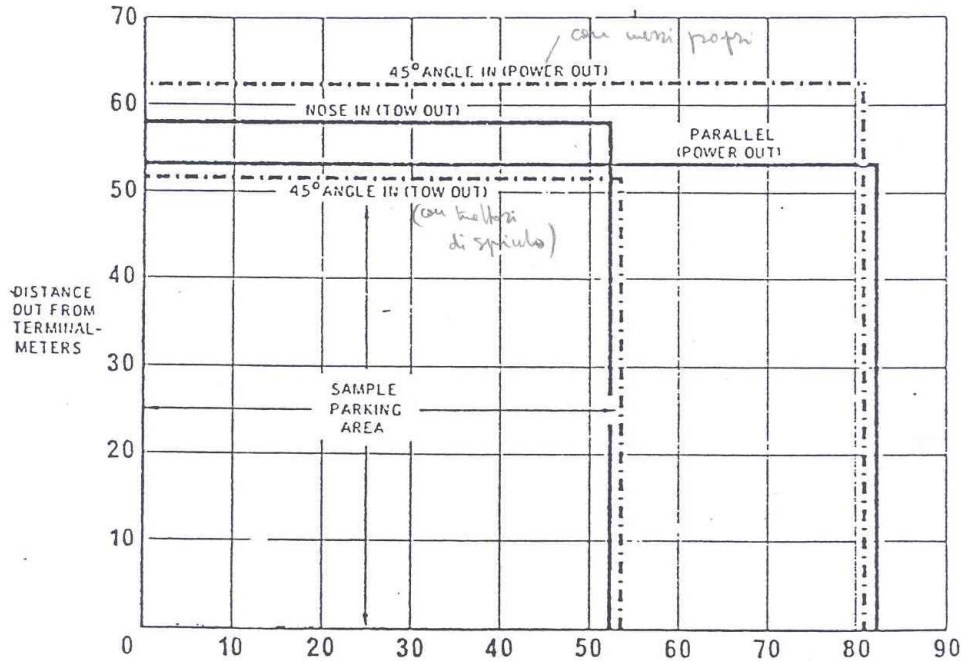

Aircraft Group	Push-out (ft., in.) ^f		Area (mq)	Taxi-out (ft., in.)		Area (mq)
	L ^d	W ^d		L ^d	W ^d	
A						
FH-227	103,1	115,2	1206	148,10	140,2	2119
YS-11B	106,3	124,11	1347	171,0	149,11	2606
BAC-111	123,6	113,6	1423	130,0	138,6	1829
DC-9-10	134,5	109,5	1494	149,2	134,5	2037
B						
DC-9-21,30	149,4	113,4	1719	149,0	138,4	2093
727 (all)	173,2	128,0	2252	194,0	153,0	3015
737 (all)	120,0	113,0	1378	145,4	138,0	2037
C						
B-707 (all)	172,11	165,9	2915	258,0	190,9	4999
B-720	156,9	150,10	2402	228,0	175,10	4072
DC-8-43,51	170,9	162,5	2817	211,10	187,5	4033
D						
DC-8-61,63	207,5	168,5	3549	252,4	193,5	4958
E						
L-1011	188,8	175,4	3361	263,6	200,4	5362
DC-10	192,3	185,4	3620	291,0	210,4	6218
F						
B-747	241,10	215,8	5298	328,0	240,8	8020

^fIncluding clearances of 20 ft wing tip to wing tip; nose to building: 30 ft, groups A and B; 20 ft, groups C and D; 10 ft, groups E and F.

^dIncluding clearances of 20 ft to other aircraft and GSE, 45 ft.

¹1 ft = 0.3048 m.

^dLength and width are based on the largest dimension in the group of aircraft.

Source: *The Apron and Terminal Building Planning Report*, prepared for the FAA by Ralph M. Parsons Company, Report FAA-RD-75-191, July 1975 (rev. March 1976); and *Planning and Design Guidelines For Airport Terminal Facilities*, FAA Advisory Circular AC 150/5360-13, April 22, 1988.

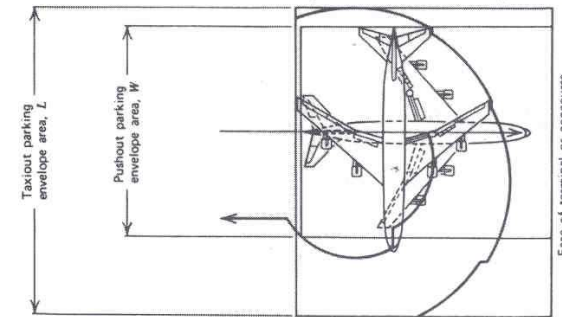

Dimensioni degli stalli e manovre (2)

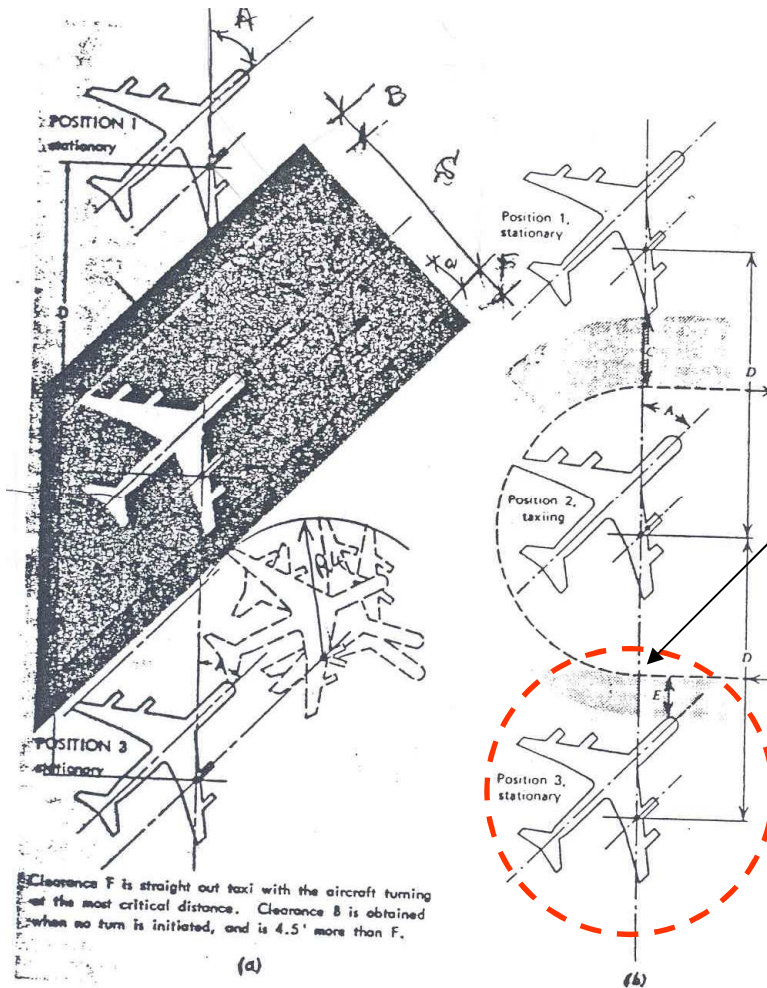

$$B = D * \text{sen}(A) - S$$

$$F = D * \text{sen}(A) - (a + R)$$

$$m = 2 * R - D$$

Dimensioni degli stalli e manovre (3)

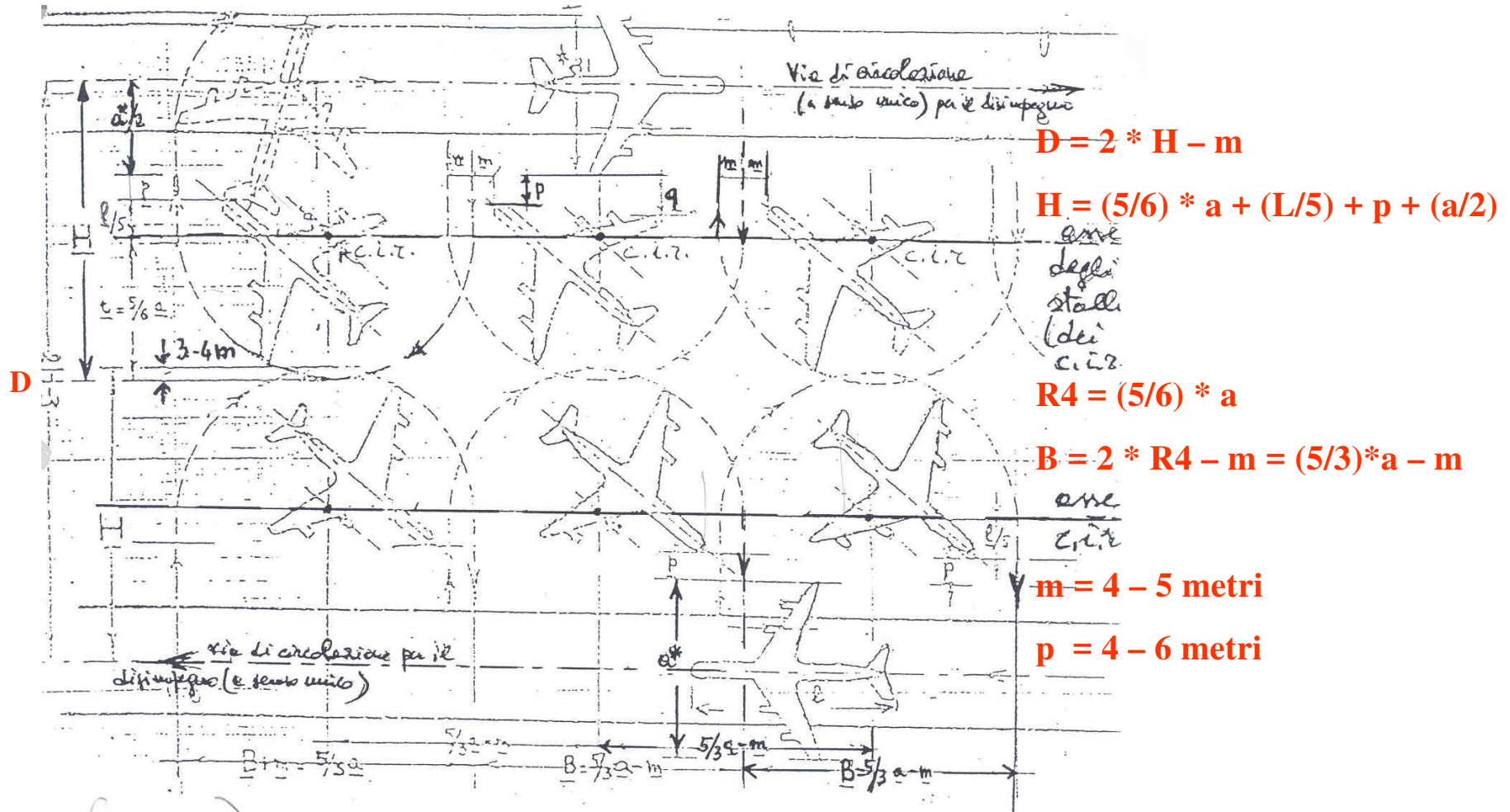

Analisi dinamica negli apron

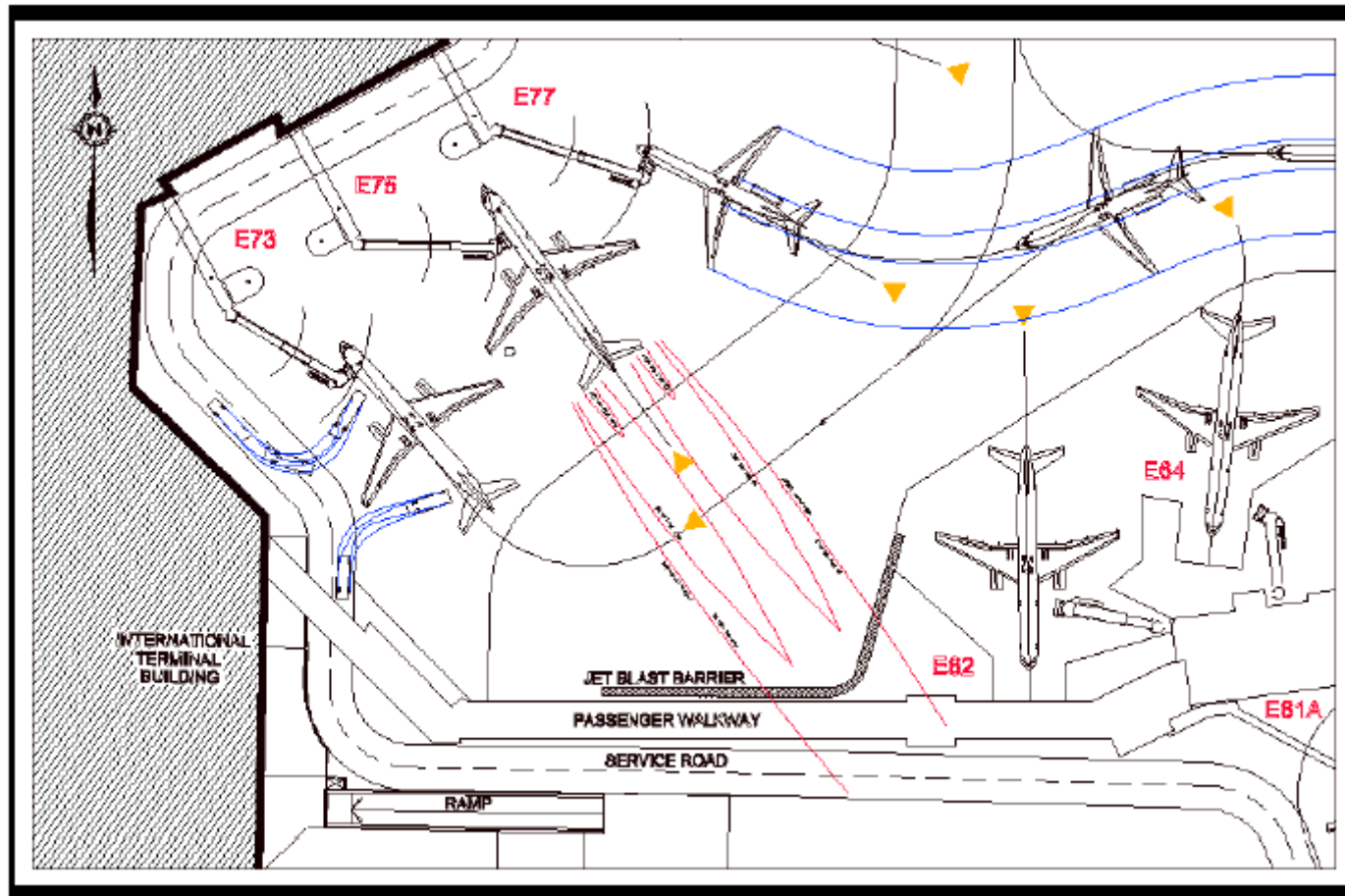

Funzione del terminal

CIRCOLAZIONE DEI PASSEGGERI

PROCESSING

SELEZIONE E ORGANIZZAZIONE DEI PASSEGGERI

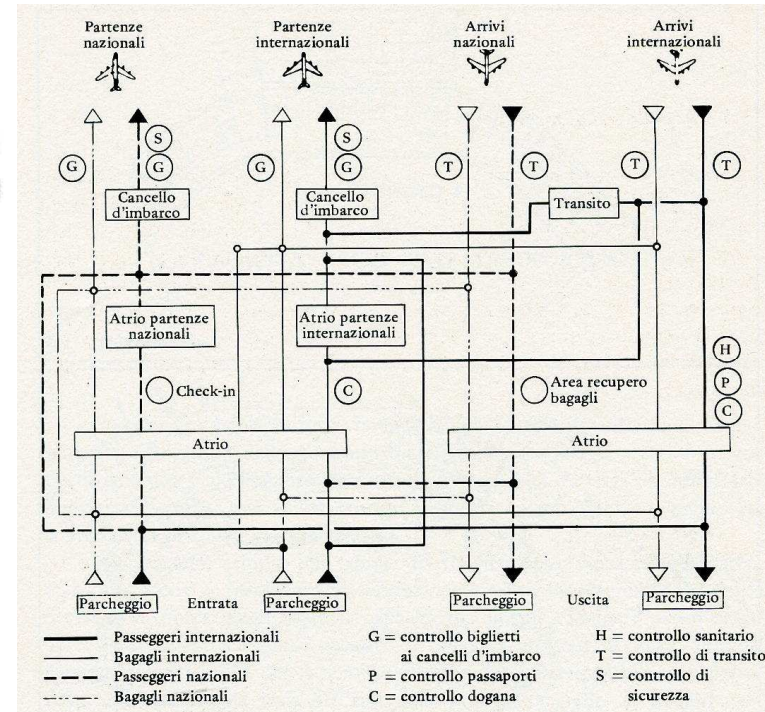
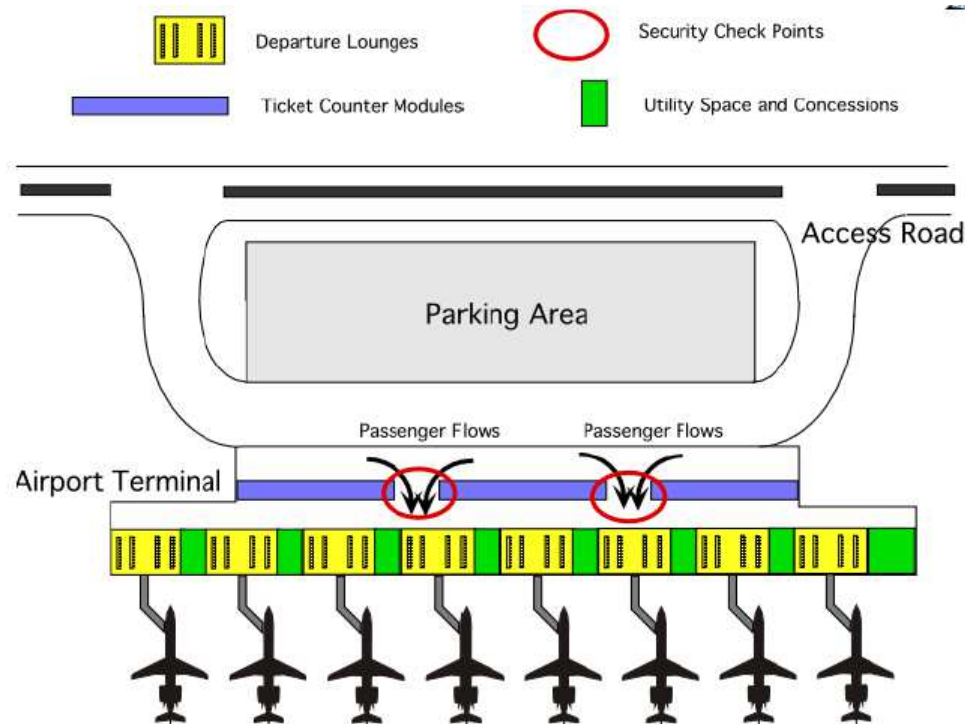

Spazi richiesti nei terminal

Domestic Terminal Space Facility	Space Required per 100 TPHP,	
	(1000 ft ²)	(100 m ²)
Ticket lobby	1.0	0.95
Airline operational	4.8	4.57
Baggage claim	1.0	0.95
Waiting rooms	1.8	1.70
Eating facilities	1.6	1.52
Kitchen and storage	1.6	1.52
Other concessions	0.5	0.48
Toilets	0.3	0.28
Circulation, mechanical, and maintenance, walls	11.6	11.05
Total	24.2	23.02

International Terminal Space Facility	Additional Space Required per 100 TPHP	
	(1000 ft ²)	(100 m ²)
Public health	1.5	1.42
Immigration	1.0	0.95
Customs	3.3	3.14
Agriculture	0.2	0.19
Visitor waiting rooms	1.5	1.42
Total	7.5	7.12
Circulation, baggage assembly, utilities, walls partitions	7.5	7.12
Total	15.0	14.24

$$TPHP = \left[\frac{(T_{annuale} / 365)}{12} \cdot 1,2 \right] \cdot 1,3$$

$$TPHP = 1000 \cdot T_{annuale} \cdot 0,731$$

↑
milioni passeggeri /anno

Livelli di servizio (LOS)

	Level of Service Standards (m ² per occupant)					
	A	B	C	D	E	F
Check-in queue area	1.8	1.6	1.4	1.2	1.0	
Wait/circulate	2.7	2.3	1.9	1.5	1.0	
Hold room	1.4	1.2	1.0	0.8	0.6	
Bag claim area (excluding claim device)	2.0	1.8	1.6	1.4	1.2	
Government inspection	1.4	1.2	1.0	0.8	0.6	

Table 2. Interpretation of Level of Service (IATA).

Legend	Remarks
A	Excellent service; free flow conditions; excellent level of comfort
B	High level of service; condition of stable flow; very few delays
C	Good level of service; stable flow; few delays
D	Adequate level of service; condition of unstable flow; acceptable delays
E	Inadequate level of service; condition of unstable flow; unacceptable delays
F	Unacceptable level of service; condition of cross flows; system breakdown

Circolazione dei passeggeri (1)

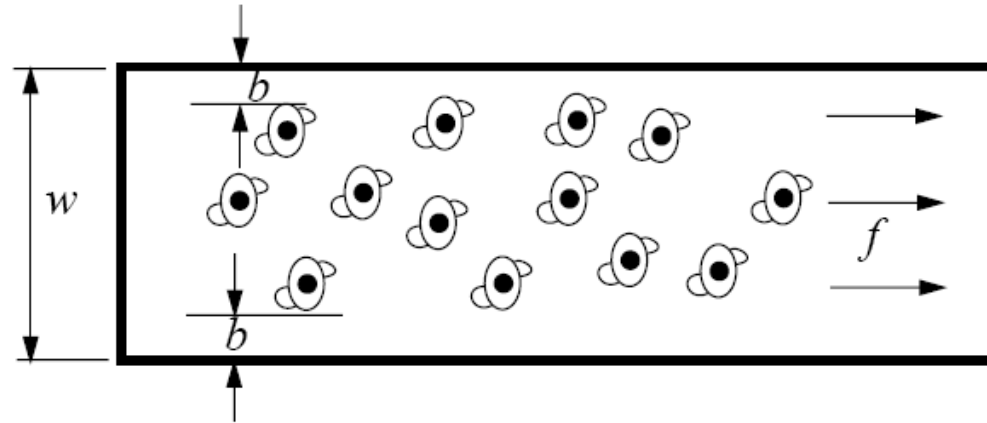

TERMINOLOGIA

VELOCITÀ PEDONALE [m/s]: è la velocità media con cui i pedoni camminano;

FLUSSO PEDONALE [ped/min]: numero di pedoni che transita in una sezione nell'unità di tempo;

FLUSSO PEDONALE PER UNITÀ DI LARGHEZZA [ped/min/m]: flusso pedonale per unità di larghezza.

DENSITÀ PEDONALE [ped/m²]: numero medio di pedoni per unità di area;

SPAZIO PEDONALE [m²/ped]: area media occupata da ciascun pedone;

PLOTONE DI PEDONI: gruppo di pedoni che viaggiano in gruppo in maniera involontaria a causa per esempio di un controllo semaforico.

Circolazione dei passeggeri (2)

Relazioni flusso – densità – velocità: $v_{ped} = S_{ped} * D_{ped} = S_{ped} / M_{ped}$

v = flusso pedonale (ped/min/m); S velocità pedonale (m/min) ; D densità pedonale (ped/m²); M spazio pedonale (m²/ped).

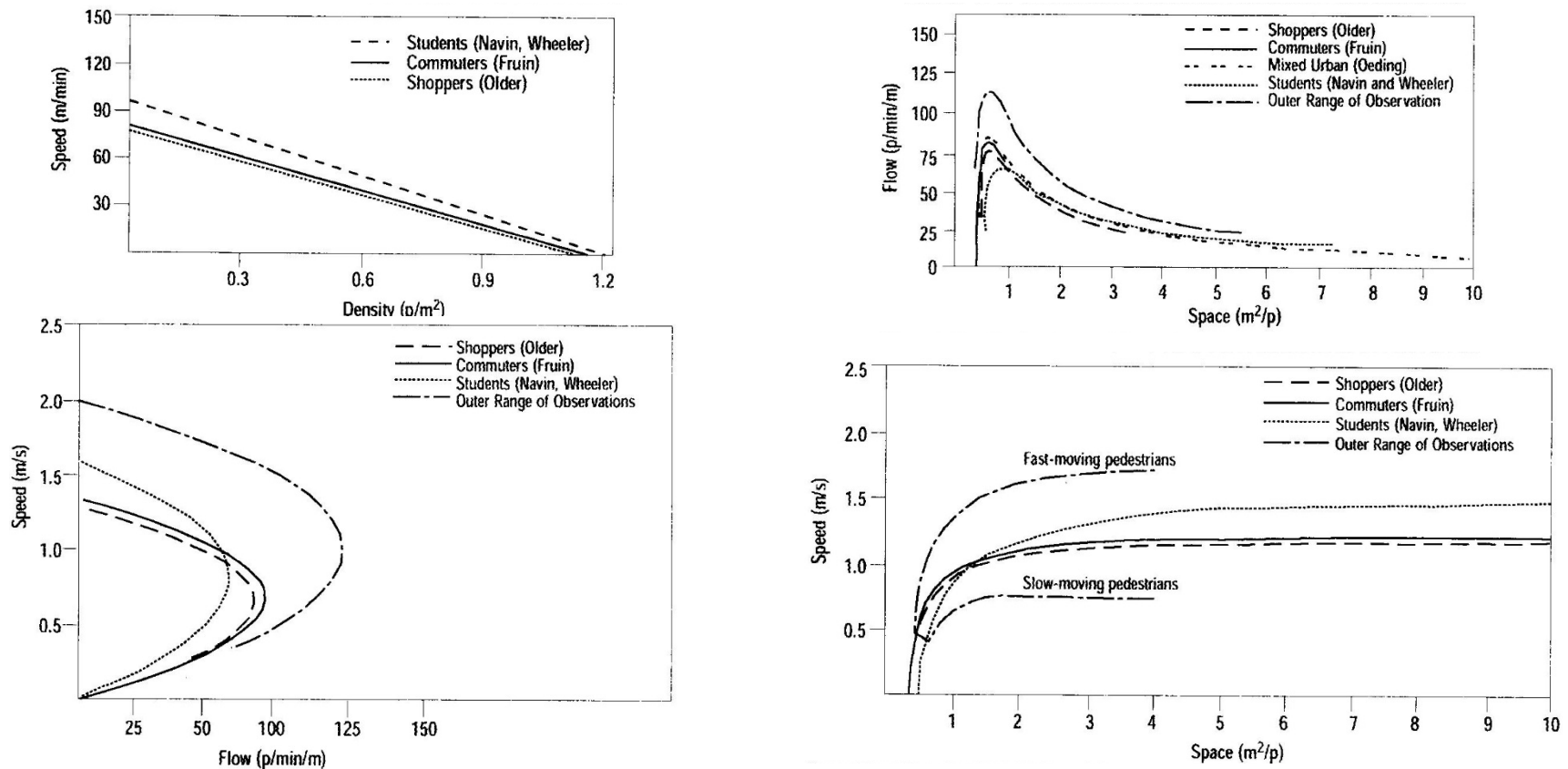

Circolazione dei passeggeri (3)

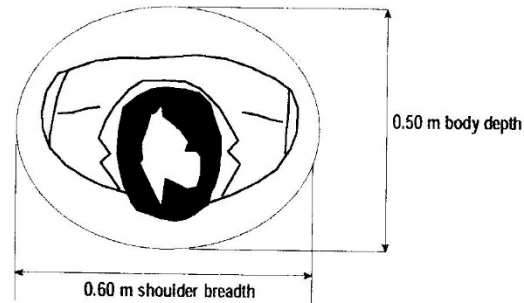

(a) Pedestrian body ellipse

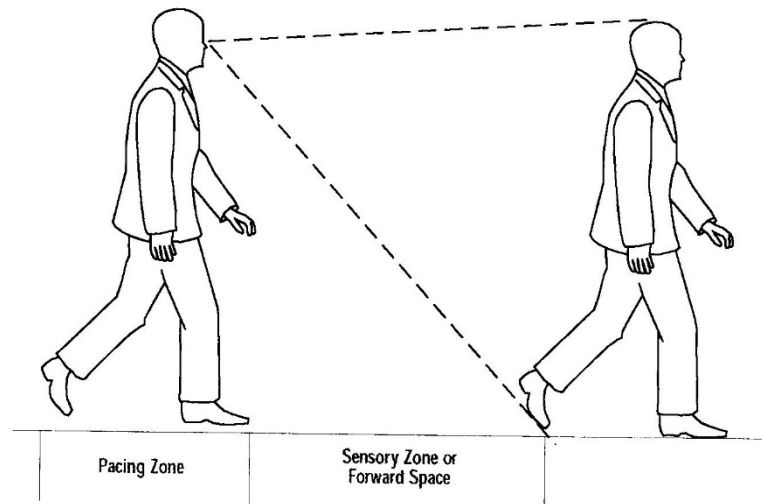

Circolazione dei passeggeri (4)

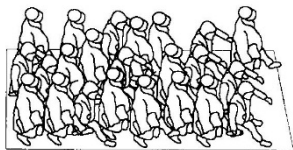
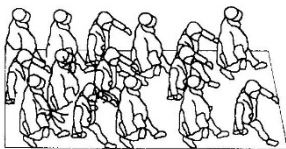
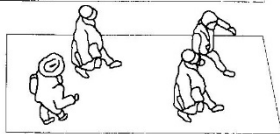
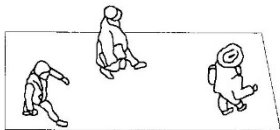
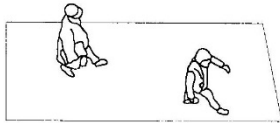
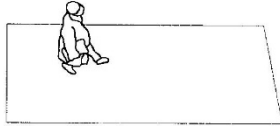

$$Q = n * v$$

$$V = \frac{WS}{WO \cdot HD}$$

EXHIBIT 18-3. AVERAGE FLOW LOS CRITERIA FOR WALKWAYS AND SIDEWALKS

LOS	Space (m ² /p)	Flow Rate (p/min/m)	Speed (m/s)	v/c Ratio
A	> 5.6	≤ 16	> 1.30	≤ 0.21
B	> 3.7–5.6	> 16–23	> 1.27–1.30	> 0.21–0.31
C	> 2.2–3.7	> 23–33	> 1.22–1.27	> 0.31–0.44
D	> 1.4–2.2	> 33–49	> 1.14–1.22	> 0.44–0.65
E	> 0.75–1.4	> 49–75	> 0.75–1.14	> 0.65–1.0
F	≤ 0.75	variable	≤ 0.75	variable

EXHIBIT 18-4. PLATOON-ADJUSTED LOS CRITERIA FOR WALKWAYS AND SIDEWALKS

LOS	Space (m ² /p)	Flow Rate ^a (p/min/m)
A	> 49	≤ 1.6
B	> 8–49	> 1.6–10
C	> 4–8	> 10–20
D	> 2–4	> 20–36
E	> 1–2	> 36–59
F	≤ 1	> 59

Note:

a. Rates in the table represent average flow rates over a 5- to 6-min period.

EXHIBIT 18-5. LOS CRITERIA FOR STAIRWAYS

LOS	Space (m ² /p)	Flow Rate (p/min/m)	Average Horizontal Speed (m/s)	v/c Ratio
A	> 1.9	≤ 16	> 0.53	≤ 0.33
B	> 1.6–1.9	> 16–20	> 0.53	> 0.33–0.41
C	> 1.1–1.6	> 20–26	> 0.48–0.53	> 0.41–0.53
D	> 0.7–1.1	> 26–36	> 0.42–0.48	> 0.53–0.73
E	> 0.5–0.7	> 36–49	> 0.40–0.42	> 0.73–1.00
F	≤ 0.5	variable	≤ 0.40	variable

Circolazione dei passeggeri (5)

Table 4. Queueing LOS Standards (Source: Fruin)

LOS	^a Average Area m ² /pr (ft ² /pr)	Interpersonal Spacing m (ft)	Description of Flow Conditions
A	>1.2 (>13)	>1.2 (>4)	Standing, circulation within queueing
B	0.9-1.2 (10-13)	1.1-1.2 (3.5-4)	Standing, partially restricted circulation
C	0.7-0.9 (7-10)	0.9-1.1 (3-3.5)	Standing, restricted circulation
D	0.3-0.7 (3-7)	0.6-0.9 (2-3)	Standing without contact; long term waiting discomfort
E	0.2-0.3 (2-3)	0.3-0.6 (1-2)	Standing without contact, crowd pressure
F	<0.2 (<2)	<0.3 (<1)	Close contact, Uncomfortable

Circolazione dei passeggeri (6)



Table 7. Typical Characteristics of Electrical Escalators (Fruin).

Width at Hip mm (in)	Width at Tread mm (in)	Theoretical Capacity (pr/hr)	Practical Capacity (pr/hr)
813 (32)	610 (24)	5,000	2,040 ^a
		6,700	2,700 ^b
1219 (48)	1016 (40)	8,000	4,080
		10,700	5,400

a. 90 ft/min linear speed

b. 120 ft/min linear speed



Processing (Biglietteria)

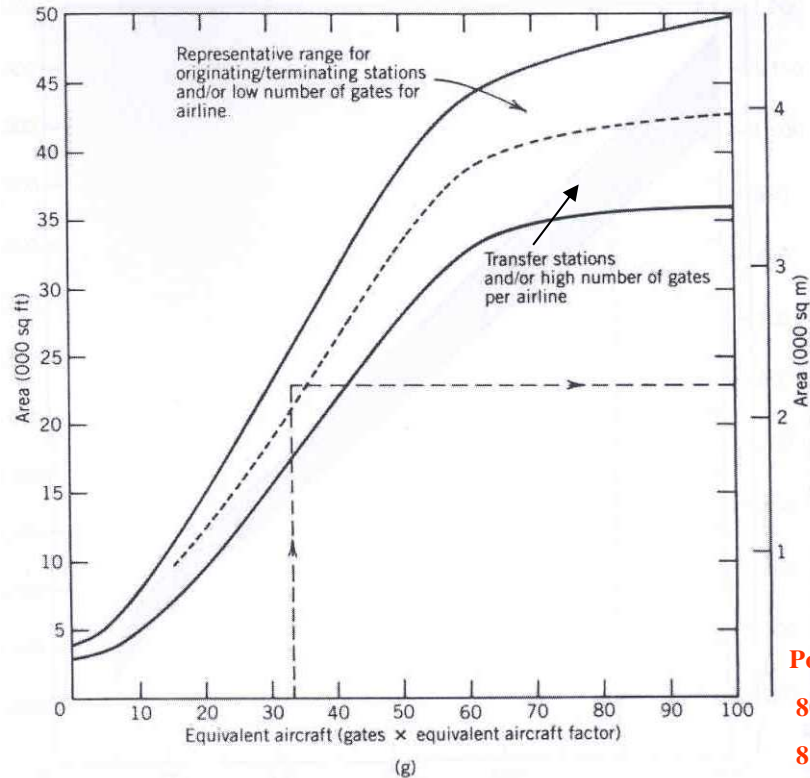

2.3g Area biglietteria

Posti	fattore eq.
80	0,6
81-110	1,0
111-160	1,4
161-210	1,9
211-280	2,4
281-420	3,5
421-500	4,6

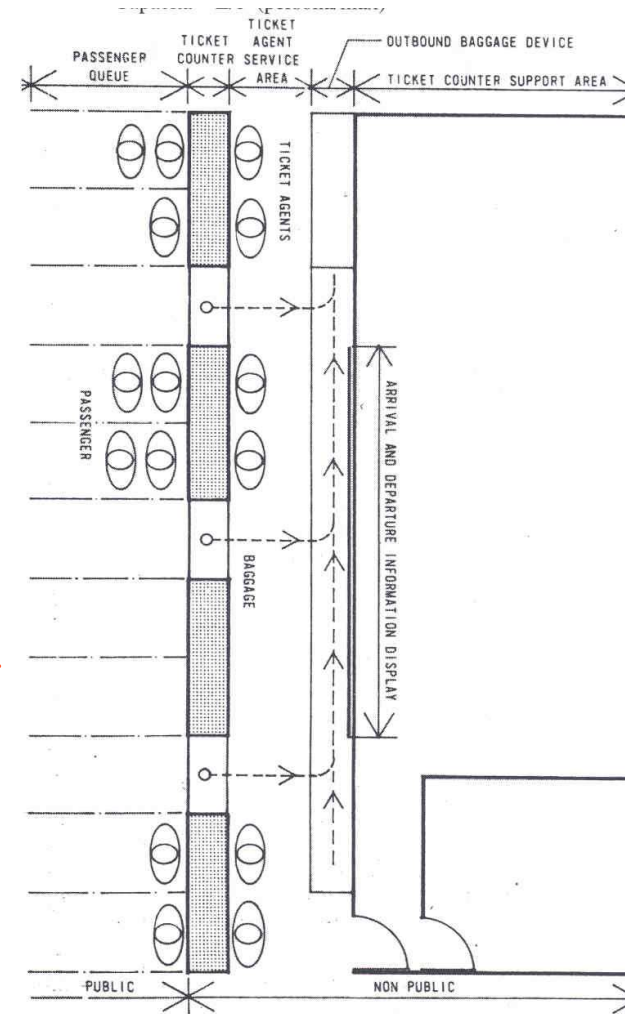

Processing (Bagagli- partenza)

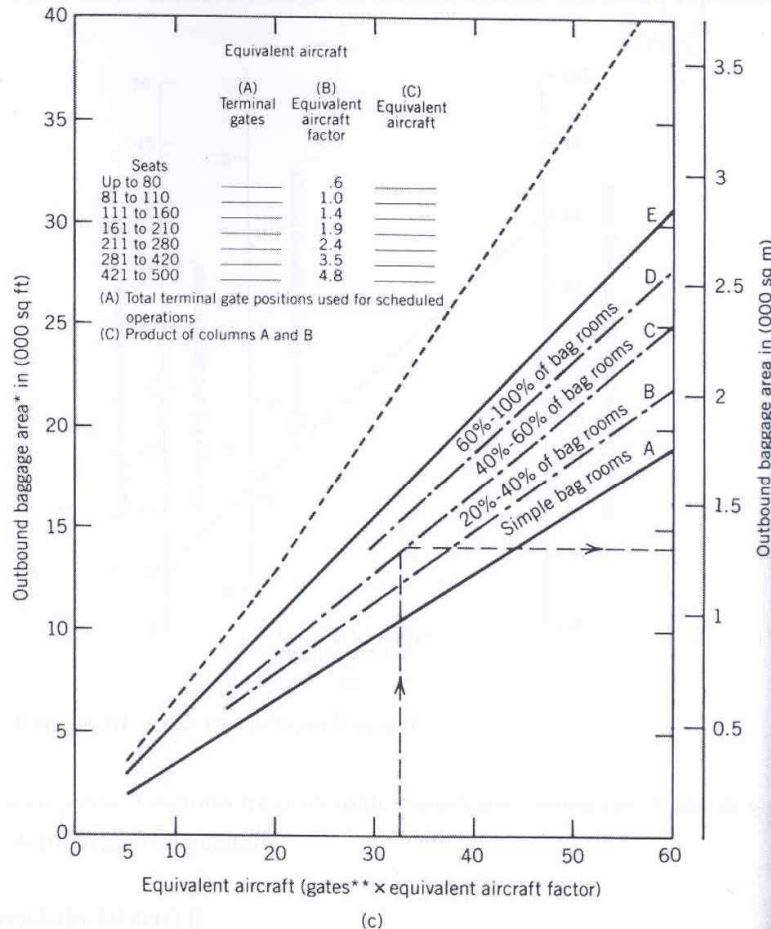
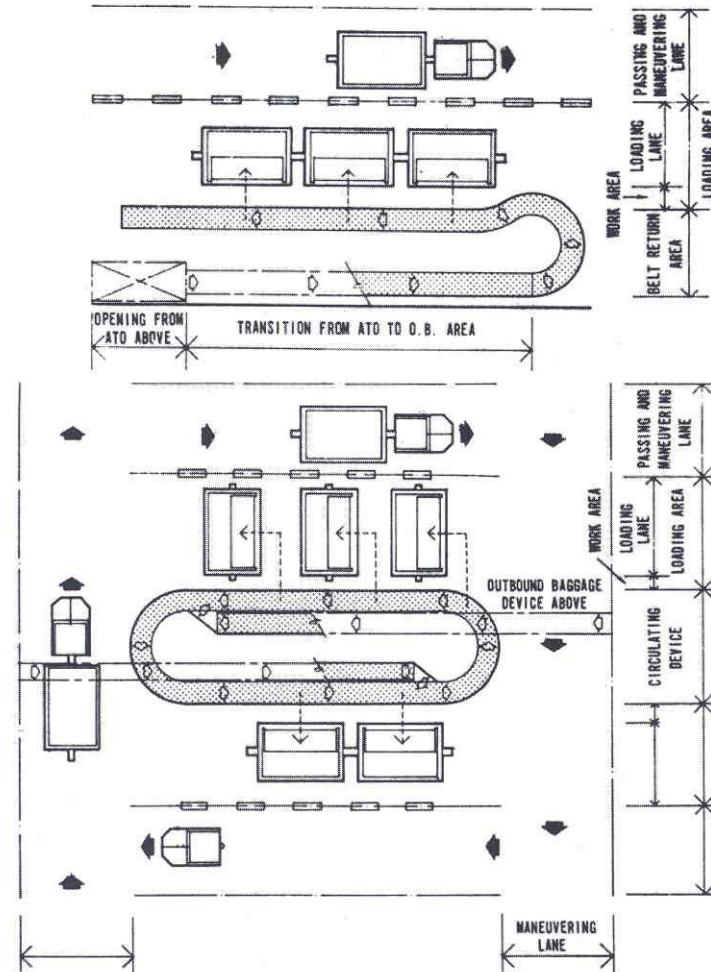

FIG. 2.3c Area bagagli in partenza



Processing (Bagagli – arrivo; 1)

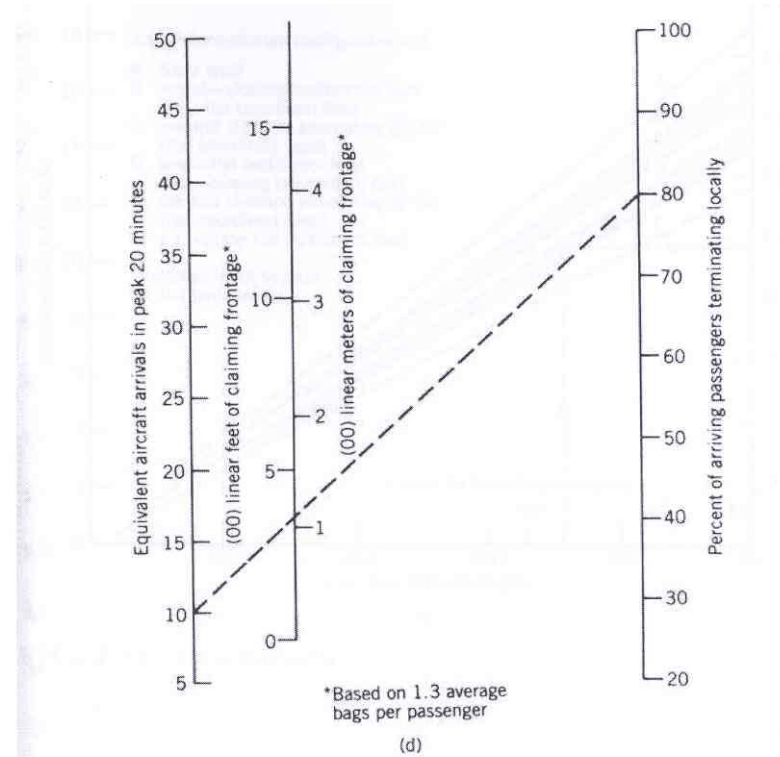
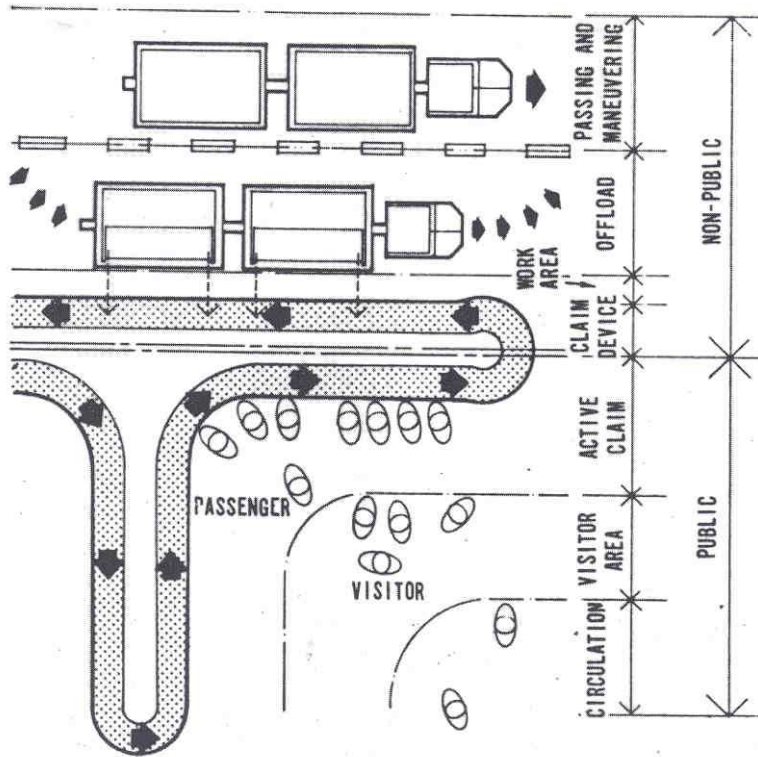
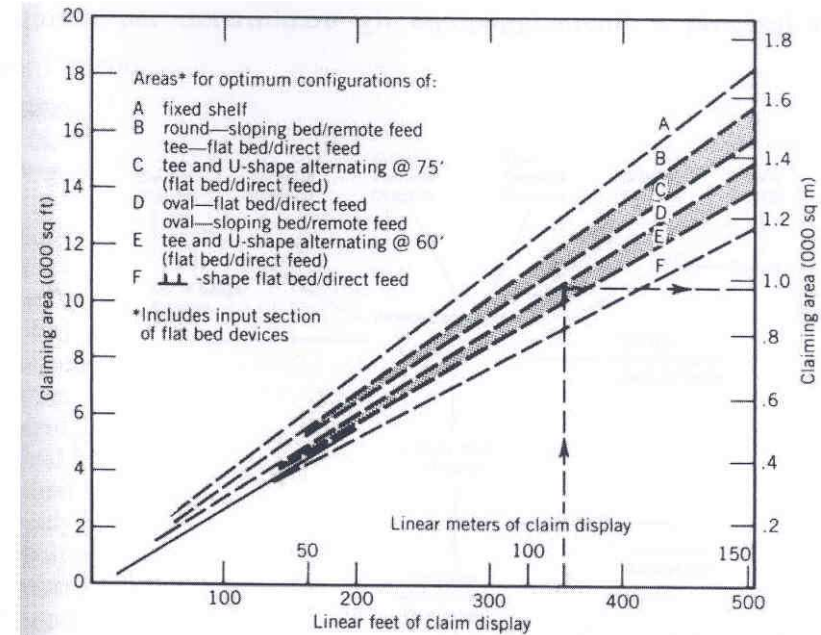
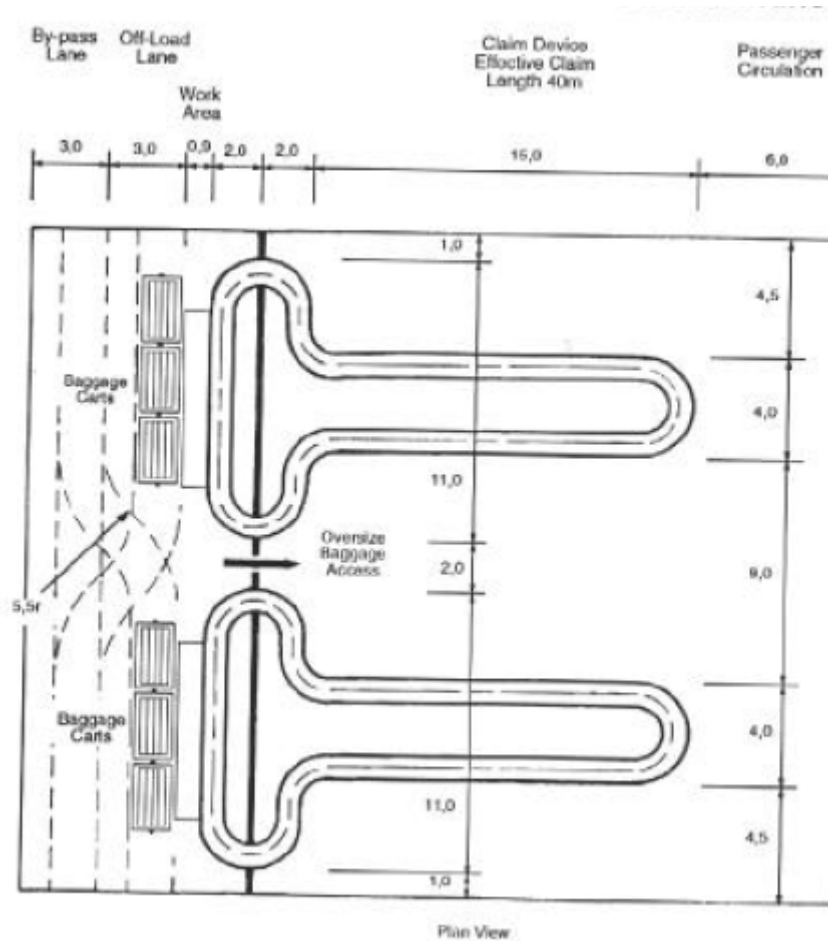
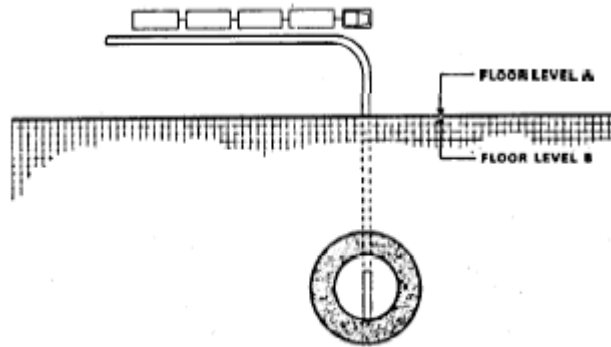

FIG. 2.3d Area riconsegna bagagli

Processing (Bagagli – arrivo; 2)



Processing (Bagagli – arrivo; 3)



CIRCULAR
REMOTE FEED SLOPING BED

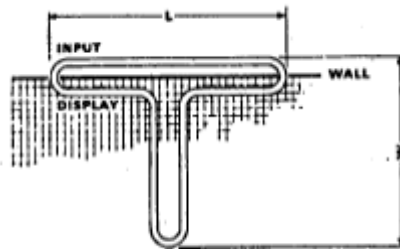

FLATBED — DIRECT FEED

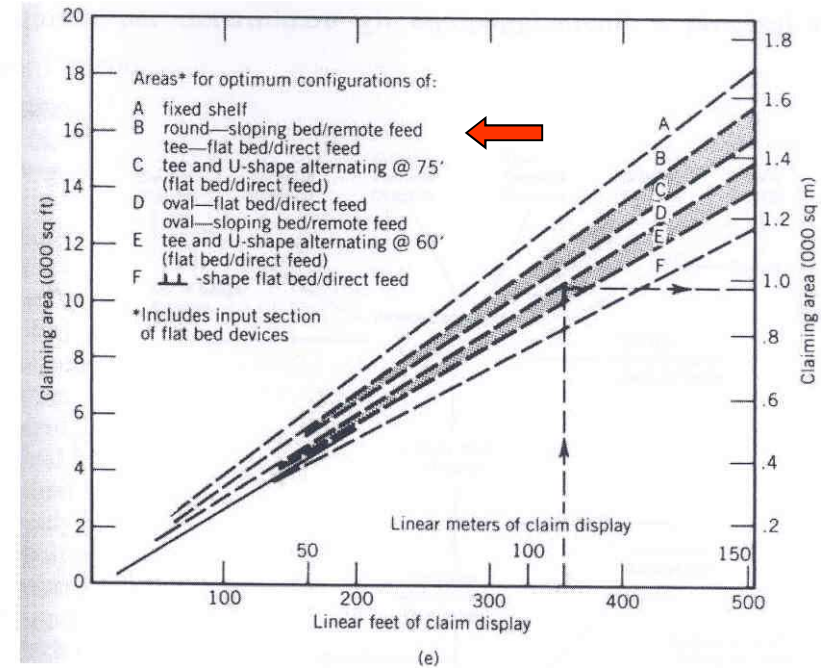

Processing (Bagagli – arrivo; 4)

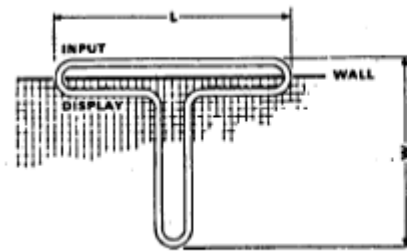

FLATBED — DIRECT FEED

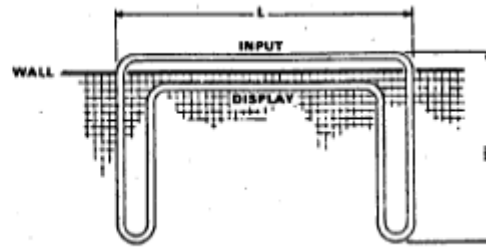

FLATBED — DIRECT FEED

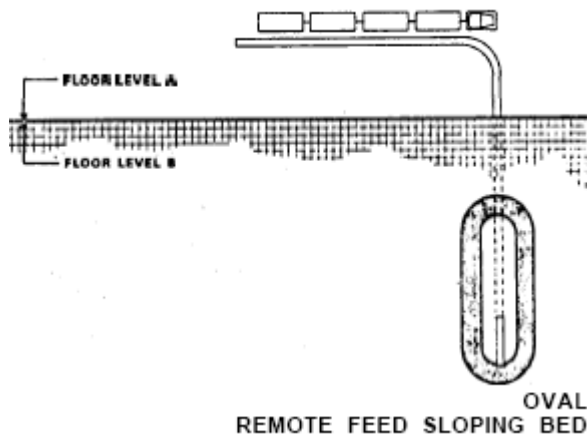

OVAL
REMOTE FEED SLOPING BED

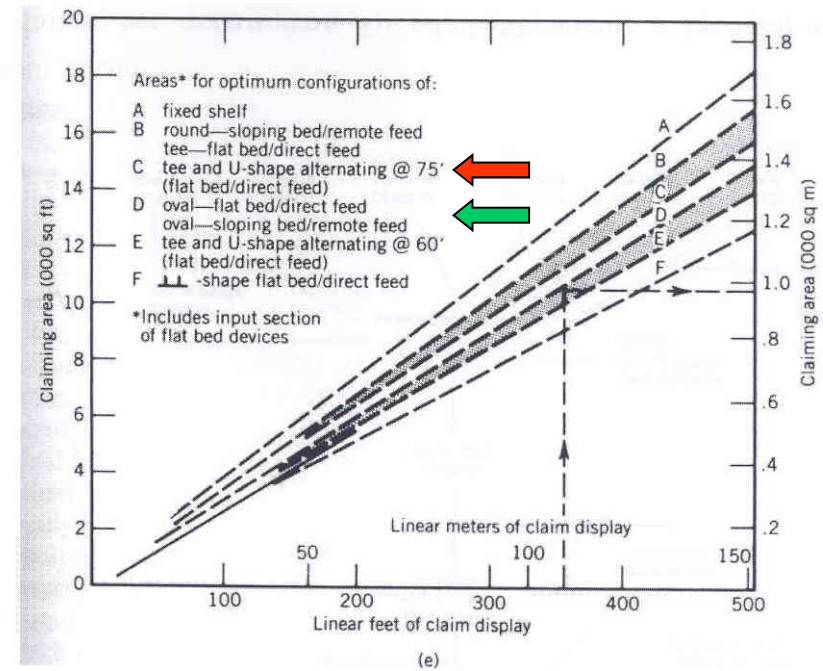

Processing - Controlli di sicurezza (1)

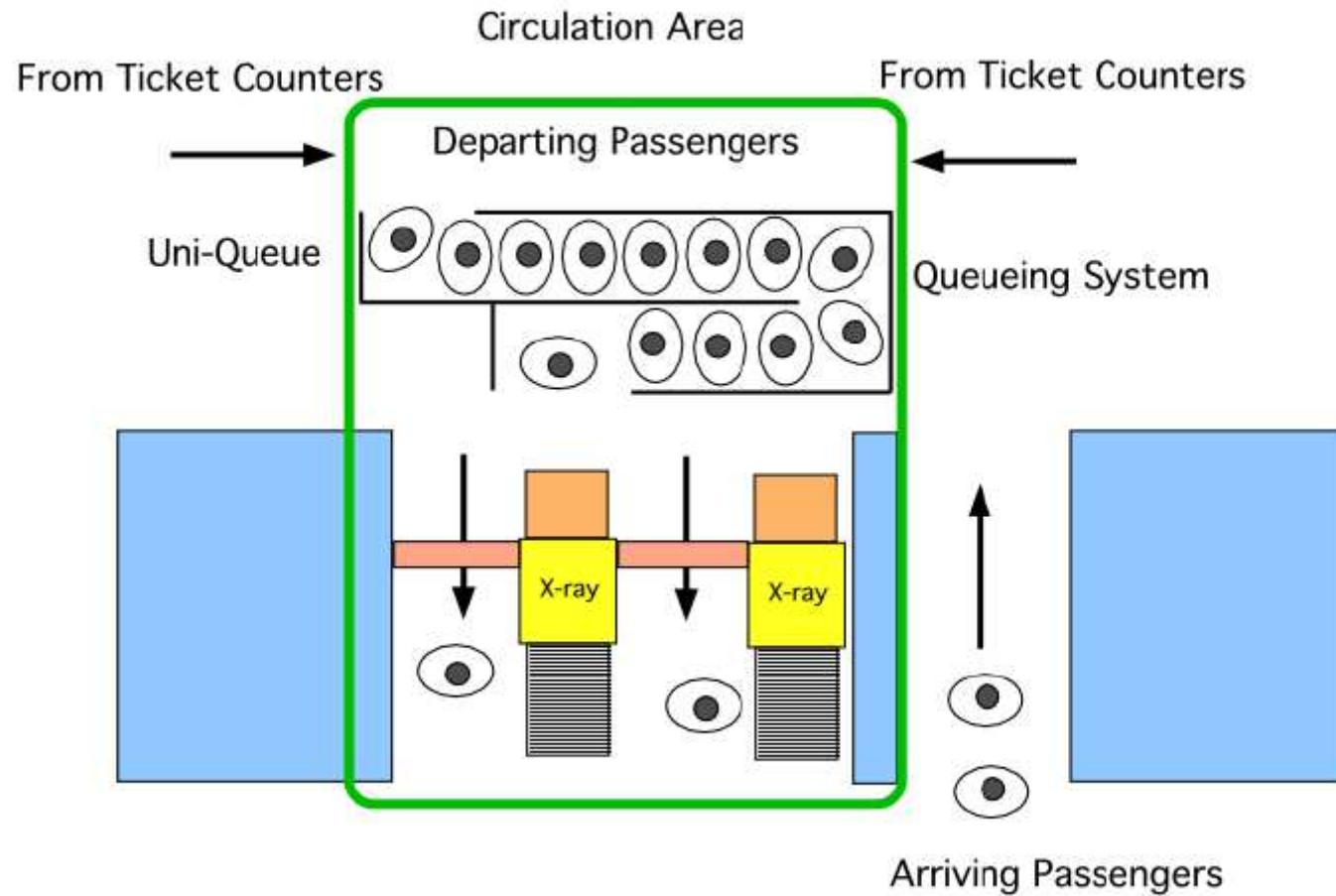

Processing - Controlli di sicurezza (2)

EXAMPLE OF PASSENGER SEARCH BY WALK-THROUGH
MAGNETOMETER WITH HAND BAGGAGE SEARCH BY X-RAY SCANNER

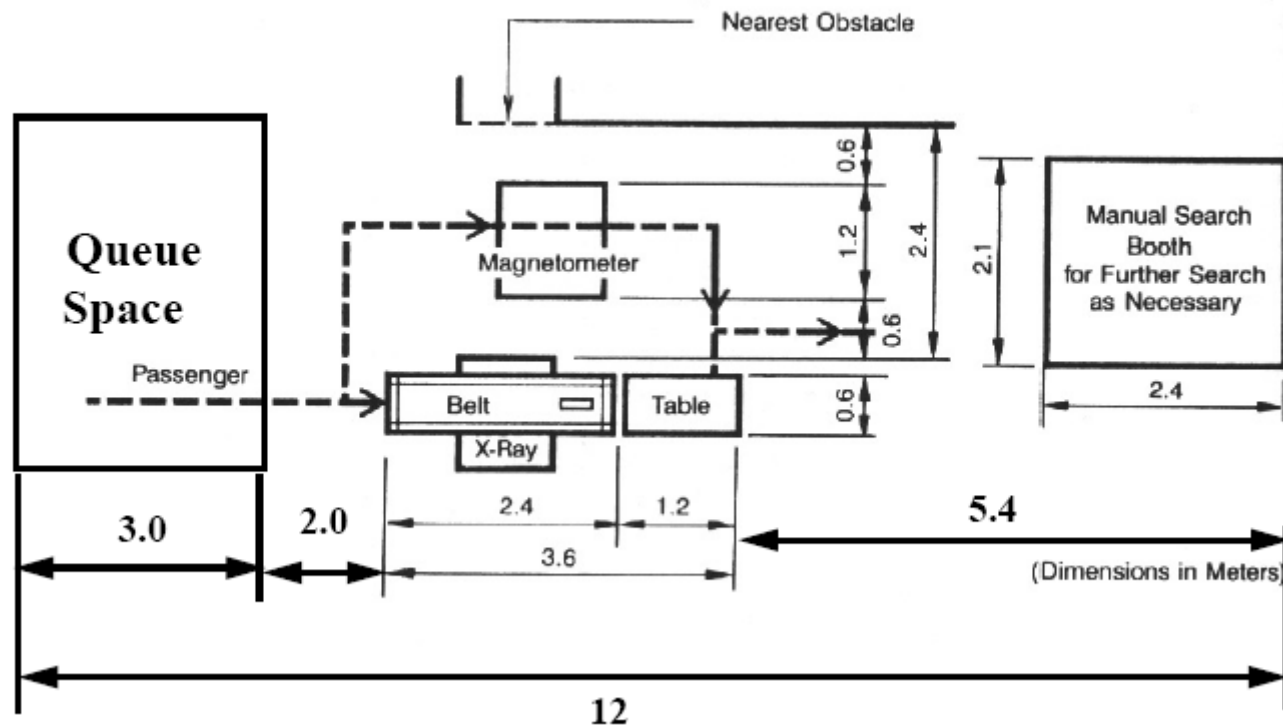

Processing - Controlli di sicurezza (3)

Controllo di 1° livello – Raggi X

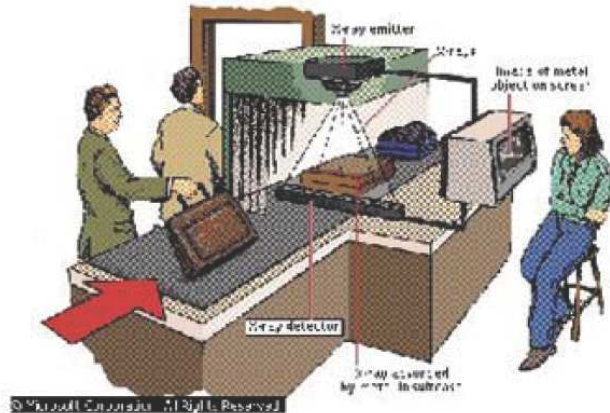

Controllo di 1° livello – Raggi X



Controllo di 1° livello – Raggi X

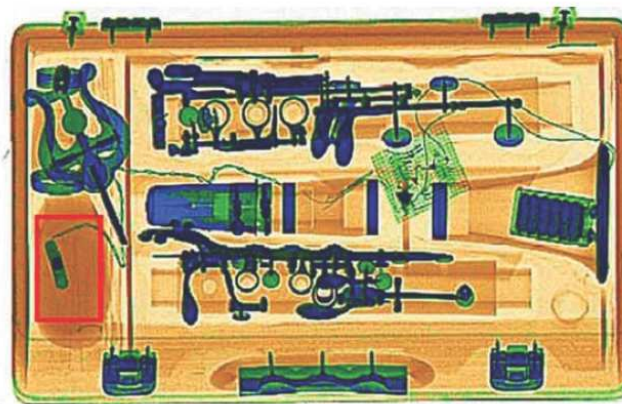

Processing - Controlli di sicurezza (4)

Controllo di 2° livello – TAC



Nuove Tecnologie - Sniffers



Nuove Tecnologie - Controllo Visivo

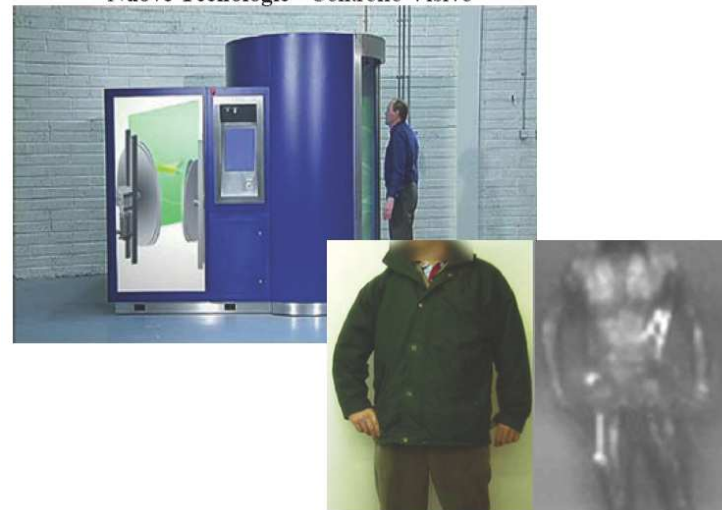

Holding space - Lounges (1)

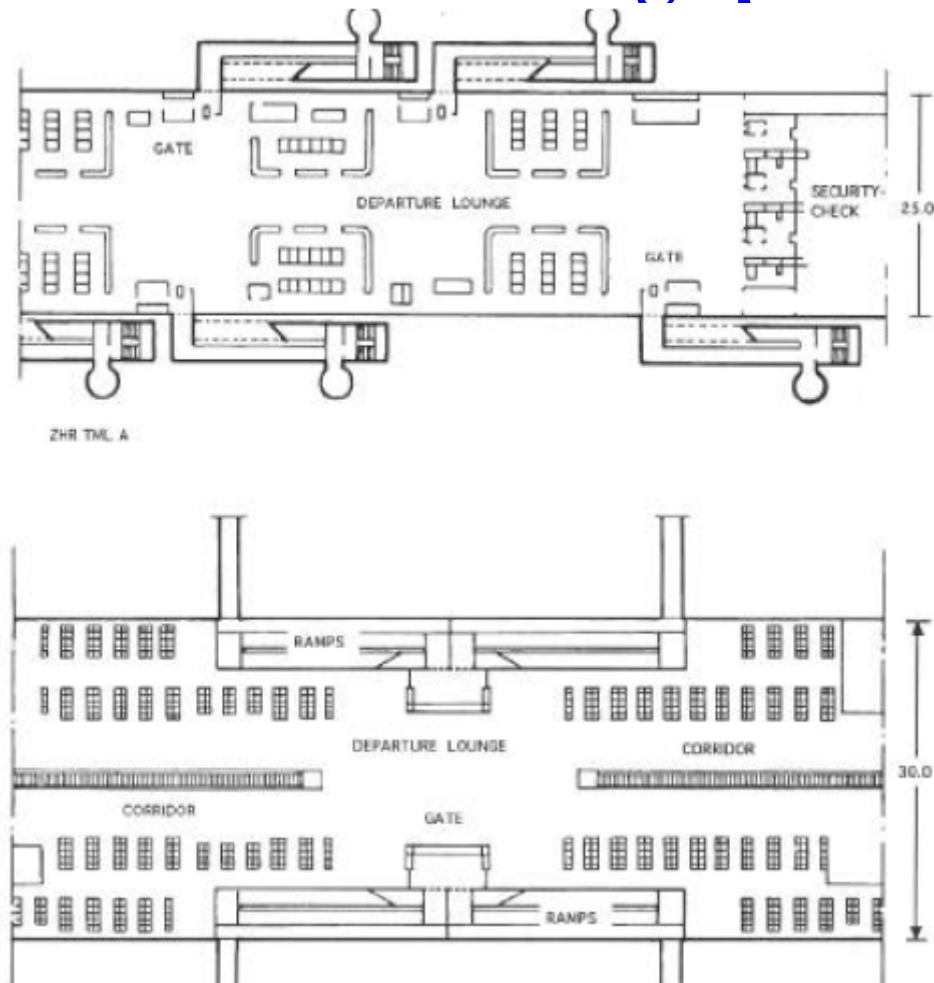

Holding space - Lounges (2)

Aircraft Type Model	Seat Capacity Range	Average Departure Lounge Size
CV-580; DC-9 -10; BAC-111; YS-11-B; M-404; F-227B	40-80 Av. 60	640 sq ft 60 sq m
B-737; B-727 -100; DC-9 -30; CV-880	90-110 Av. 100	1080 sq ft 100 sq m
DC-8 -50; DC-8 -62; B-727 -200; B-727 -300; B-707 (all); B-720	120-160 Av. 140	1500 sq ft 140 sq m
DC-8 -61, B-757	170-210 Av. 190	2050 sq ft 190 sq m
DC-10, L-1011, A300, B-767, MD11	220-280 Av. 250	2690 sq ft 250 sq m
B-747	300-420 Av. 360	3870 sq ft 360 sq m
High capacity Wide body	420-500 Av. 460	4950 sq ft 460 sq m

2.3f Dimensione area partenze per tipo di aeroplano

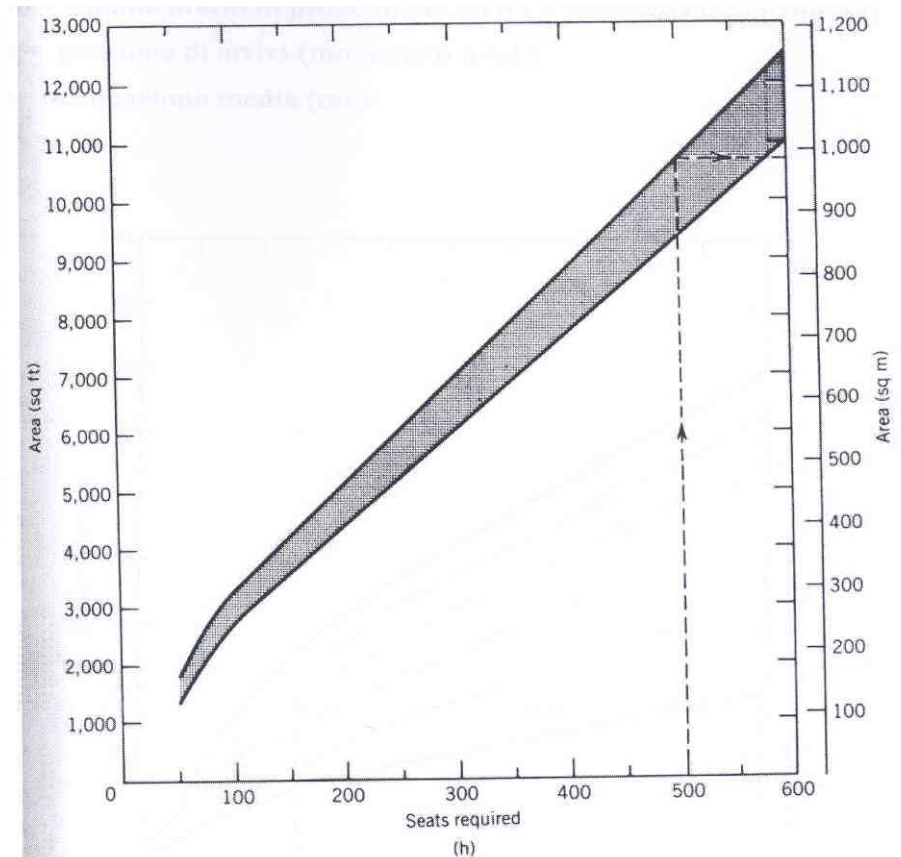

FIG. 2.3h Zone d'attesa

Holding space - ricreativi

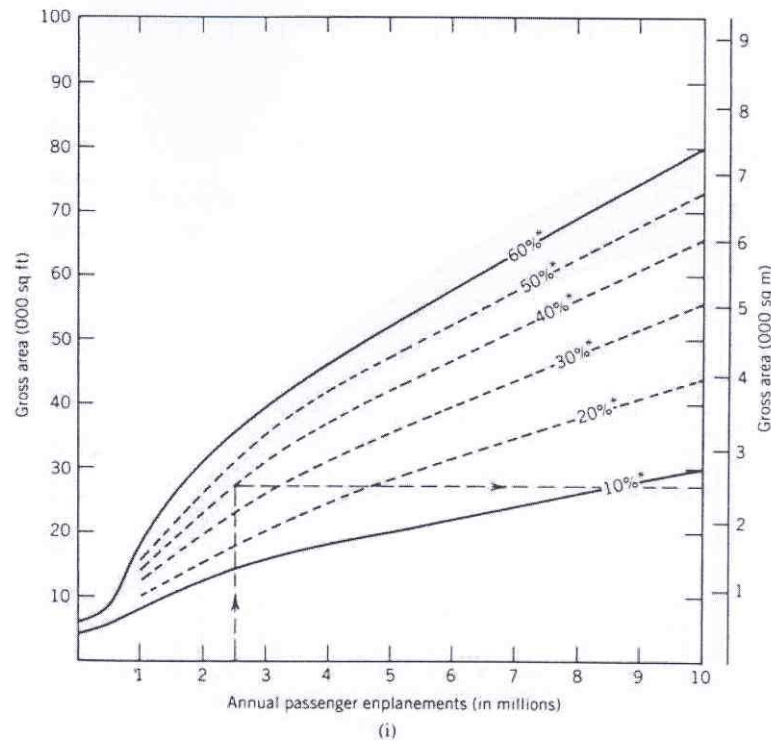

FIG. 2.3i Aree bar-ristorante

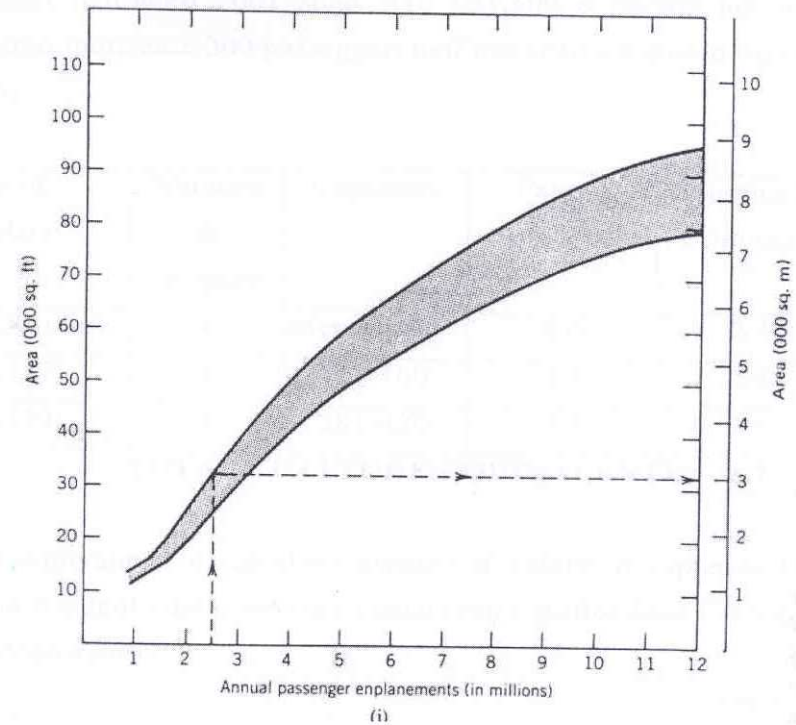

FIG.2.3j Concessioni ed altri servizi