

Prof. Ing. Dario Pozzetto

Department of Engineering and Architecture – University of Trieste

Via Valerio, 10 – 34127 Trieste – Tel: 040.558.3805 / 7982 Fax: 040.558.3812

E-mail: pozzetto@units.it

INDUSTRIAL PLANTS II

Chapter four (part 1):

Air conditioning plants in industrial environments

DOUBLE DEGREE MASTER IN

“PRODUCTION ENGINEERING AND MANAGEMENT”

CAMPUS OF PORDENONE

UNIVERSITY OF TRIESTE

Air conditioning plants in industrial environments

Introduction and definitions

The air conditioning of an industrial environment confined consist in the set of processes carried out in order to form or maintain certain temperature and humidity conditions appropriate to the use of that environment by part of man, in all weather conditions outside, all year round (microclimate).

The air conditioning of an environment includes, in relation to the characteristics of the internal and the external climate, with relative production of endogenous heat, the following functions: cooling or heating, ventilation with or without filtering, air humidification or dehumidification.

Air conditioning plants in industrial environments

Introduction and definitions

The factors that determine the microclimate of an industrial environment are:

- temperature;
- relative humidity;
- movement of air;
- purity of the air.



The relative humidity is a quantity used to measure the moisture present in the air. It is defined as the ratio of the partial pressure of water vapor contained in a gaseous mixture of air and water vapor with respect to the saturated vapor pressure, expressed in percentage. A relative humidity of 100% indicates that the gaseous mixture contains the maximum amount of moisture as possible to the given conditions of temperature and pressure.

Air conditioning plants in industrial environments

Introduction and definitions

The values of these factors that determine the microclimate depend on the specific use of the premises to be air-conditioned in consideration of:

- well-being of people;
- machining process from raw materials or semi-finished products to finished products.



The **wellness** is a state that involves all aspects of the human being. The concept has undergone numerous changes and expansions over the years, which led to a vision of broader and more comprehensive term, no longer centered on the idea of the absence of disease, but as an overall state of good physical health, mental and physical.

Air conditioning plants in industrial environments

Introduction and definitions

The plants that will produce the required microclimate are sized according to thermal loads, both summer and winter.

The buildings used for industrial, craft and similar represents the category E.8 of the general classification of buildings by categories according to Presidential Decree 412/93 and subsequent amendments and additions.

Where a building consists of its individual parts as belonging to different categories, they must be treated separately, and that is in each category that competes.

Air conditioning plants in industrial environments

Introduction and definitions

In particular:

- If the part allocated to other assets (buildings of category by E.1 to E.7) is not extract from the complex and is predominant, at whole building you apply the categories E.1-E.7;
- If the portion of the building used for industrial or handicraft item is extract, you apply the category E.8.

General classification of buildings by category according to the DPR August 26, 1993, n. 412

E.1 – Buildings used as residences and assimilated

E.2 – Buildings used as offices and assimilated

E.3 – Buildings used as hospitals, clinics or nursing homes and assimilated

E.4 – Buildings used as recreational activities, or membership of worship and assimilated

E.5 – Buildings used as activity business and assimilated

E.6 – Buildings used as sports activities

E.7 – Buildings used as school activities at all levels and assimilated

Air conditioning plants in industrial environments

Calculation of thermal loads winter

The entry into force of Law 10/91 and its implementing regulations (DPR 412/93, D.M. 13.12.1993 and Presidential Decree 551/1999), even before the introduction of the Legislative Decree 192/2005, requires designers, planning supervisors and testers to the calculation procedure of the conventional and normalized energy needs for space heating and, in particular, the determination of thermal insulation and its thermal losses.

Air conditioning plants in industrial environments

Calculation of thermal loads winter

The energy requirement for the conventional air conditioning in winter is the amount of global primary energy demand, in the course of a year, to maintain the temperature in heated to the constant value of 20°C, with an adequate air during a heating season whose period is conventionally set in different climatic zones.

The **climatic zones** are:

- **Zone A**: municipalities that have a number of degree-day not exceeding 600
- **Zone B**: municipalities that have a number of degree-days greater than 600 and not more than 900
- **Zone C**: municipalities that have a number of degree-days greater than 900 and not more than 1,400
- **Zone D**: municipalities that have a number of degree-days greater than 1,400 and not more than 2,100
- **Zone E**: municipalities that have a number of degree-days greater than 2,100 and not more than 3,000
- **Zone F**: municipalities that have a number of degree-days greater than 3,000

Air conditioning plants in industrial environments

Calculation of thermal loads winter

The normalized energy demand for space heating (FEN) is the conventional energy demand divided by the heated volume and the degrees day of the locality ($\text{kJ}/\text{m}^3 \text{ GG}$).

It is indicated with **degrees day** the heating requirements of a given geographical area relative to current regulations on the heating/cooling of the housing. The numerical value represents the sum, extended to all days of a conventional twelve-month period, of only differences of positive (or negative) between the daily temperature conventional, fixed in Italy at 20°C , and the average outside temperature daily.

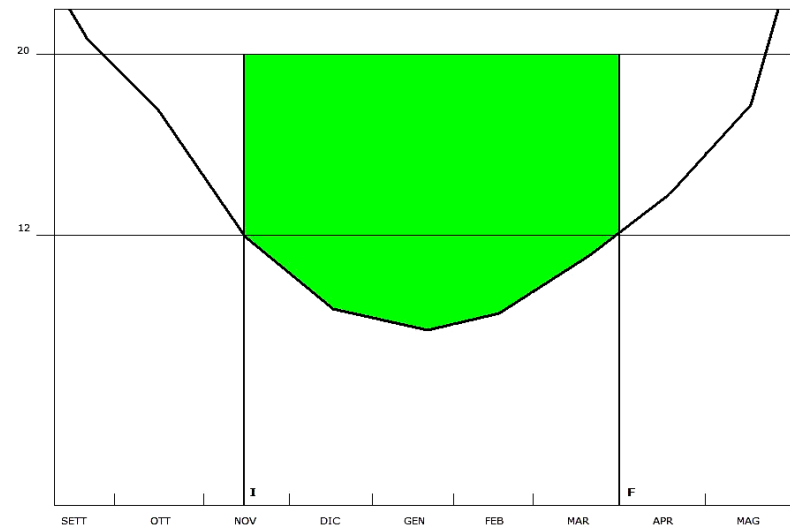

Air conditioning plants in industrial environments

Calculation of thermal loads winter

The thermal insulation of buildings is mandatory for:

- new buildings;
- buildings to be restored, resulting in the change of at least 50% of the pre-existing works, such as curtain walls, ceiling or attic of open spaces etc., which result in an increase of the glass surface greater than 5%;
- buildings in which the heating system is added or changed with an increase of the thermal power greater than the original 10%



Air conditioning plants in industrial environments

Calculation of thermal loads winter

The procedure for the calculation of the heat demand for heating of industrial buildings is as set out by UNI EN 12831: 2006. In the same norm shall consider the heat losses related to:

- transmission of heat through the structures to the outside;
- heat transfer through the structure to unheated spaces or temperatures different from those of the environment examined;
- thermal bridges;
- air changes or ventilation of locals.

Air conditioning plants in industrial environments

Calculation of thermal loads winter

The calculation of heat loss of the building industry is executed to regime, to constant temperatures, a continuous heating and neglecting any endogenous sources of heat, such as artificial lighting, presence of people, machines and operators drive and so on. These contributions are instead considered when estimating the annual energy requirements of the building (FEN) according to the UNI EN ISO 13790: 2008.

The heat loss in the conditions of the project must be compensated by the contribution provided by the thermal heat generator with its potentiality helpful.

The calculation of the dispersions for each environment allows dimensioning the heating elements both at irradiation (radiators, radiant panels etc.), both at convection (convectors, fan coils etc.).

Air conditioning plants in industrial environments

Calculation of thermal loads winter

a) *transmission of heat through the structures to the outside*

We can consider two types of structures:

a1) opaque structures (walls, floors, ceilings)

In steady state, in a building the heat flow outward through an opaque structure Q (W) is given by the relation:

$$Q_{dso} = K \cdot S \cdot (T_i - T_e)$$

where:

T_i = internal temperature (°C);

T_e = external temperature (°C);

S = surface of the structure considered (wall, ceiling etc.) that faces the outside (m²);

Air conditioning plants in industrial environments

Calculation of thermal loads winter

a) *transmission of heat through the structures to the outside*

We can consider two types of structures:

a1) opaque structures (walls, floors, ceilings)

K = coefficient of global transmission or transmittance of the unitary structure ($\text{W/m}^2 \cdot ^\circ\text{C}$), that for a generic structure is expressed by the relation:

$$K = \frac{1}{\frac{1}{h_i} + \sum_{j=1}^n \frac{s_j}{\lambda_j} + \frac{1}{C} + \frac{1}{C_a} + \frac{1}{h_e}}$$

$1/h_i$ = thermal resistance of admission in which h_i is the resistance liminar on the inner surface of the structure relative to the thermal exchange between the inner surface and the air that laps. Its value depends on the position and the wall surface temperature and that of the air and is:

- internal surface with vertical heat flux horizontal: $8 \text{ W/m}^2 \text{ } ^\circ\text{C}$;
- internal surfaces with horizontal heat flow upward (ceilings): $9 \text{ W/m}^2 \text{ } ^\circ\text{C}$;
- internal surfaces with horizontal heat flow downwards (floors): $6 \text{ W/m}^2 \text{ } ^\circ\text{C}$;

Air conditioning plants in industrial environments

Calculation of thermal loads winter

a) *trasmission of heat through the structures to the outside*

We can consider two types of structures:

a1) opaque structures (walls, floors, ceilings)

s_i/λ_i = thermal resistance of the i -th homogeneous material in which the layer thickness is measured (m) and λ_i is the thermal conductivity of the material (W/m °C), which is the ability of a material to transmit heat to conduction. By virtue of Law 10/91, the degree of isolation of the structures is high and involves the interposition of at least one layer of material with low conductivity;

$1/C = R$ = thermal resistance of non homogeneous material of which C is the conductance of the layer (W/m² °C);

Air conditioning plants in industrial environments

Calculation of thermal loads winter

a) *transmission of heat through the structures to the outside*

We can consider two types of structures:

a1) opaque structures (walls, floors, ceilings)

$1/C_a = R_a$ = thermal resistance of non homogeneous material of which C_a is the conductance of the layer ($W/m^2 \cdot ^\circ C$). The transmission of heat by convection (the recommended values of the thickness of interspaces 2-3 cm). The values of thermal resistance used are:

- vertical cavity with horizontal flow: $0,17 \text{ m}^2 \cdot ^\circ C/W$;
- horizontal air interspace with heat flow down (flooring etc. horizontal air interspace with heat flow down (flooring etc.): $0,21 \text{ m}^2 \cdot ^\circ C/W$;
- air interspace with horizontal heat flow upward (floors etc.): $0,17 \text{ m}^2 \cdot ^\circ C/W$;

Air conditioning plants in industrial environments

Calculation of thermal loads winter

a) *transmission of heat through the structures to the outside*

We can consider two types of structures:

a1) opaque structures (walls, floors, ceilings)

$1/h_e$ = thermal resistance of emission in which h_e is the “resistance liminar” or coefficient of thermal adduction surface on the outer face of the wall measured ($W/m^2 \text{ } ^\circ C$), which is the amount of heat that in steady state passes through a unit surface area in contact of the air to a temperature jump unit. Its value depends on the characteristics of weather locations considered, in particular of the wind speed, and the position of the surface under examination. The values to be used are of the “resistance liminar”:

Velocity of air (m/s)	< 1,5	2	2,5	3	4	6
Resistance liminar ($W/m^2 \text{ } ^\circ C$)	23	26	28	30	35	42

Air conditioning plants in industrial environments

Calculation of thermal loads winter

a) *transmission of heat through the structures to the outside*

We can consider two types of structures:

a1) opaque structures (walls, floors, ceilings)

In the case of external walls that can be invested frequently from wind speeds greater than 4 m/s, the value of h_e and is detectable by the relations:

- surface horizontal and vertical (upward flow):

$$h_e = (2,3 + 10,5 \cdot \sqrt{w})$$

- horizontal surface (downward flow):

$$h_e = 0,7 \cdot (2,3 + 10,5 \cdot \sqrt{w})$$

where w is the velocity of wind (m/s)

Air conditioning plants in industrial environments

Calculation of thermal loads winter

a) *transmission of heat through the structures to the outside*

We can consider two types of structures:

a1) **opaque structures (walls, floors, ceilings)**

Example of multilayer wall

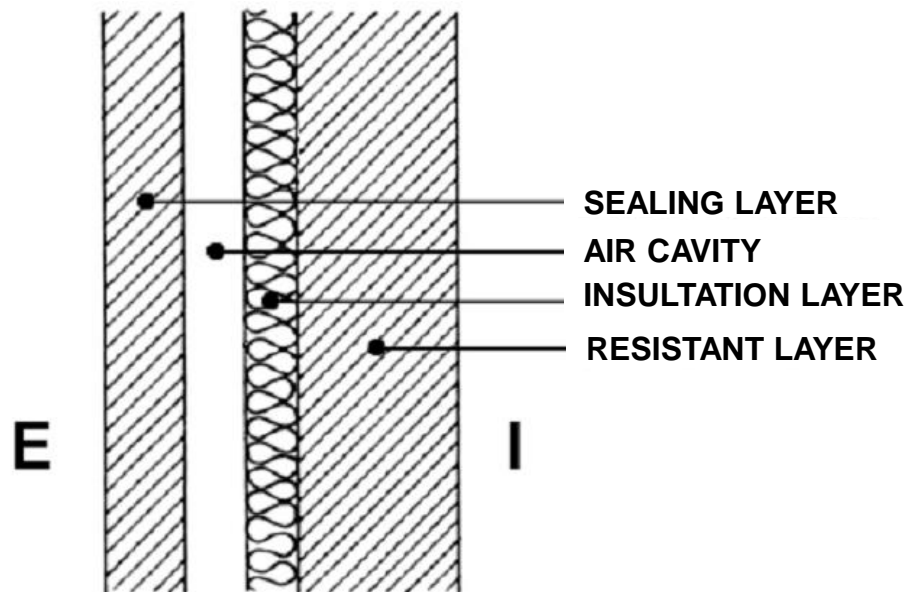

Air conditioning plants in industrial environments

Calculation of thermal loads winter

a) *trasmission of heat through the structures to the outside*

We can consider two types of structures:

a1) opaque structures (walls, floors, ceilings)

The physical parameters for the materials used in construction are (UNI 10351: 1994):

- density of the dry material ρ (kg/m³);
- permeability of the steam δ_a determined in the range of 0-50% relative humidity and δ_u determined in the time interval 50-95% (kg/m s Pa · 1012);
- conductivity of reference of the material λ_m (W/m °C);
- percentage increase m to take account of average working conditions;
- conductivity of calculation λ (W/m °C).

The values of the thermal resistance of the walls and floors are recognized by the norm UNI 10355: 1994

Air conditioning plants in industrial environments

Calculation of thermal loads winter

a) *trasmission of heat through the structures to the outside*

We can consider two types of structures:

a2) transparent structures

The procedure for unitary transmittance of transparent building components can be deduced from the norm UNI EN ISO 10077-1: 2007 and EN ISO 10077-2, which takes into account different types of glass (simple, stratified, with surface films, with cavity etc.) and the related frames. Also provided are the values of added thermal resistance in the presence of shutters closed.

Air conditioning plants in industrial environments

Calculation of thermal loads winter

a) *transmission of heat through the structures to the outside*

We can consider two types of structures:

a2) **transparent structures**

The thermal transmittance of a windowed building component, consisting of the window frame and glass, is given by the relation:

$$K_s = \frac{S_v \cdot K_v + S_f \cdot K_f}{S_v + S_f}$$

where:

S_v = area of the glass element (m²);

K_v = thermal transmittance of the glass element (W/m² °C);

S_f = area of the frame (m²);

K_f = thermal transmittance of the frame (W/m² °C).

Air conditioning plants in industrial environments

Calculation of thermal loads winter

a) *transmission of heat through the structures to the outside*

We can consider two types of structures:

a2) transparent structures

The thermal transmittance of a transparent component, be it a single glass or a glass multiple, is given by the relation:

$$K_v = \frac{1}{\frac{1}{h_i} + \sum_{j=1}^n r_j \cdot s_j + \sum_{i=1}^{n-1} R_{si} + \frac{1}{h_e}}$$

where:

$1/h_e = R_e$ = external superficial thermal resistance ($m^2 \text{ }^\circ\text{C/W}$);

r = resistivity of the glass sheet ($m \text{ }^\circ\text{C/W}$);

s = thickness of the glass (m);

R_s = thermal resistance of the layer enclosed between the two sheets ($m^2 \text{ }^\circ\text{C/W}$);

$1/h_i = R_i$ = internal superficial thermal resistance ($m^2 \text{ }^\circ\text{C/W}$);

n = number of sheets constituting the transparent component

Air conditioning plants in industrial environments

Calculation of thermal loads winter

a) *transmission of heat through the structures to the outside*

We can consider two types of structures:

a2) transparent structures

According to UNI EN ISO 10077-1: 2007 and 10077-2: 2004 is suggested to adopt the following values of the resistance liminar h_e and h_i :

$$h_e = 25 \text{ W/m}^2 \text{ } ^\circ\text{C};$$
$$h_i = 3,6 + 4,4 \cdot \frac{\varepsilon}{0,837} \text{ W/m}^2 \text{ } ^\circ\text{C}.$$

Air conditioning plants in industrial environments

Calculation of thermal loads winter

a) *transmission of heat through the structures to the outside*

We can consider two types of structures:

a2) transparent structures

The following table shows the values of the thermal resistance of air gaps R_s in function of the emissivity of the surface ε and thicknesses.

Thickness gap (mm)	ε			
	0,2	0,4	0,8	Untreated surface
6	0,19	0,16	0,13	0,13
9	0,26	0,21	0,16	0,15
12	0,32	0,25	0,18	0,17
15	0,36	0,28	0,20	0,19
50	0,34	0,26	0,19	0,18
100	0,31	0,25	0,18	0,17

Air conditioning plants in industrial environments

Calculation of thermal loads winter

a) *transmission of heat through the structures to the outside*

We can consider two types of structures:

a2) transparent structures

The calculation of the transmittance unitary of the frame K_t is laborious for the complexity of the configuration and the number of types of windows. The table shows some values of transmittance unitary

Frame material	Characteristics of the frame	Trasmittance unitary (W/m ² °C)
Wood	Average width if the frame 30 mm 50 mm 100 mm	2,20 1,90 1,42
Metal	Without cutting thermal With cutting thermal	7,0 3,1 – 3,7
Polyurethane	With metal core With an air chamber	2,6 2,4
PVC – empty profile	With two chambers With three chambers	2,0 1,8

Air conditioning plants in industrial environments

Calculation of thermal loads winter

a) *transmission of heat through the structures to the outside*

We can consider two types of structures:

a2) **transparent structures**

The presence of external shutters or blinds lowered reduces the thermal transmittance of the window which can be calculated by the following equation:

$$K_{fs} = \frac{1}{\frac{1}{K_s} + \Delta R}$$

where:

K_{fs} = thermal transmittance of the window with shutter down ($\text{W}/\text{m}^2 \text{ } ^\circ\text{C}$);

K_s = thermal transmittance of the frame base ($\text{W}/\text{m}^2 \text{ } ^\circ\text{C}$);

ΔR = thermal resistance additional ($\text{m}^2 \text{ } ^\circ\text{C}/\text{W}$).

Air conditioning plants in industrial environments

Calculation of thermal loads winter

a) *transmission of heat through the structures to the outside*

We can consider two types of structures:

a2) transparent structures

ΔR = thermal resistance additional ($\text{m}^2 \text{ }^\circ\text{C/W}$), that for some types of shutter is detectable from the table.

Type of shutter	ΔR ($\text{m}^2 \text{ }^\circ\text{C/W}$)		
	Low permeability to air	Average permeability to air	High permeability to air
Aluminum	0,15	0,12	0,09
Wood and plastic without foam	0,22	0,16	0,12
Wood and plastic with foam	0,26	0,19	0,13
Wood (from 25 to 30 mm)	0,30	0,22	0,14

Air conditioning plants in industrial environments

Calculation of thermal loads winter

b) calculation of the temperature in the unheated premises

To calculate the heat flux from a heated room adjacent to an unheated it is necessary to determine the temperature of the latter; UNI EN 12831: 2006 proposed a series of reference situations that allow you to solve the problem without resorting to complex computations and often unreliable. The table shows some cases.

Description of premises	Temperature (°C)	Correction to be made	
		if $T_i \neq 20^\circ\text{C}$	if $T_i \neq -5^\circ\text{C}$
Wineries with doors and windows closed	5	$(T_i - 20) \cdot 0,4$	$(T_e + 5) \cdot 0,6$
Attics with tiles well sealed	-2	$(T_i - 20) \cdot 0,1$	$(T_e + 5) \cdot 0,9$
Premises with 2 exterior walls without windows	12	$(T_i - 20) \cdot 0,6$	$(T_e + 5) \cdot 0,4$
.....

Air conditioning plants in industrial environments

Calculation of thermal loads winter

c) *thermal bridges*

The thermal bridges are discontinuities construction or joints in structural elements of the building, where higher concentrations occur and changes to the one-dimensional heat flow.

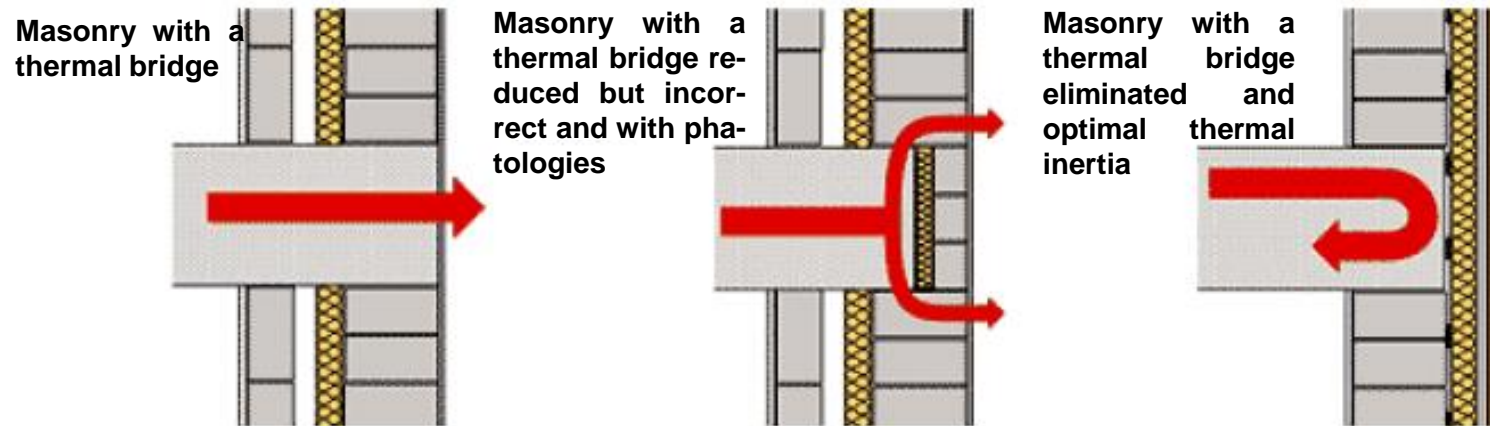

Air conditioning plants in industrial environments

Calculation of thermal loads winter

c) *thermal bridges*

The thermal bridges are discontinuities construction or joints in structural elements of the building, where higher concentrations occur and changes to the one-dimensional heat flow.

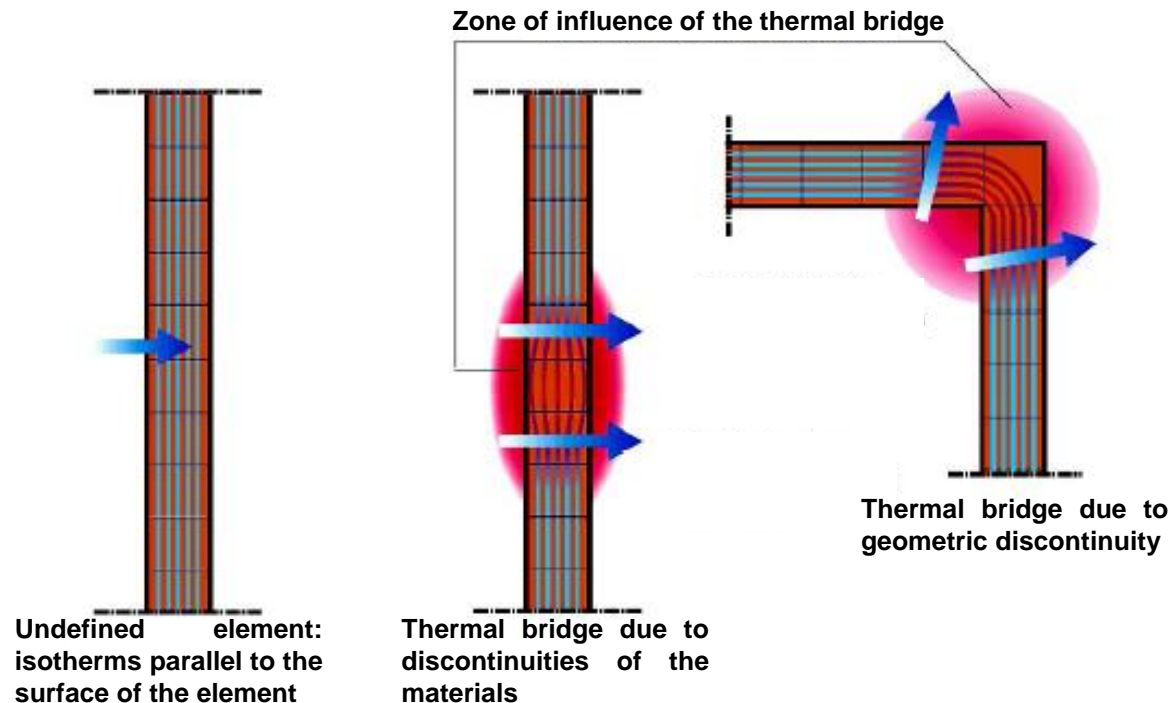

Air conditioning plants in industrial environments

Calculation of thermal loads winter

c) *thermal bridges*

It has a thermal bridge in correspondence of a node between the elements having different coefficients of transmission and in particular:

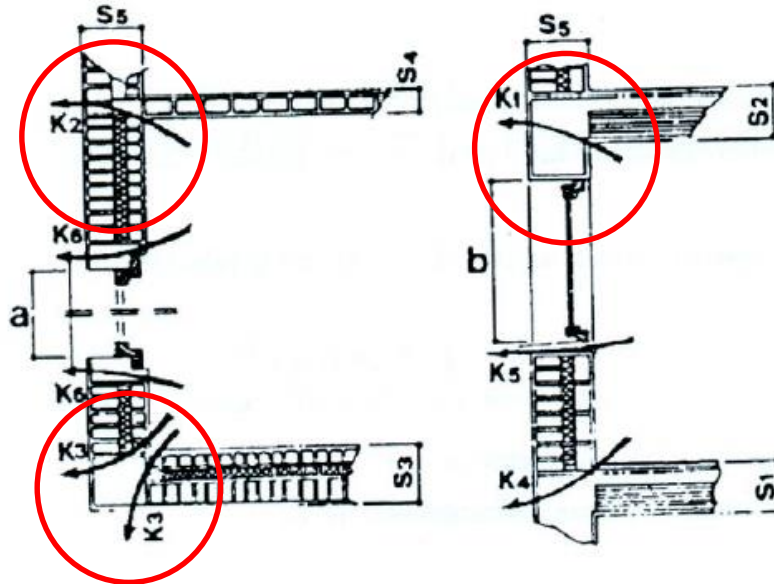

- horizontal joint between the ceiling and the wall infill (K1);
- vertical joint between the infill wall and the internal partition (K2);
- vertical joint of the two vertical infill walls with corner pillar (K3);

Air conditioning plants in industrial environments

Calculation of thermal loads winter

c) *thermal bridges*

It has a thermal bridge in correspondence of a node between the elements having different coefficients of transmission and in particular:

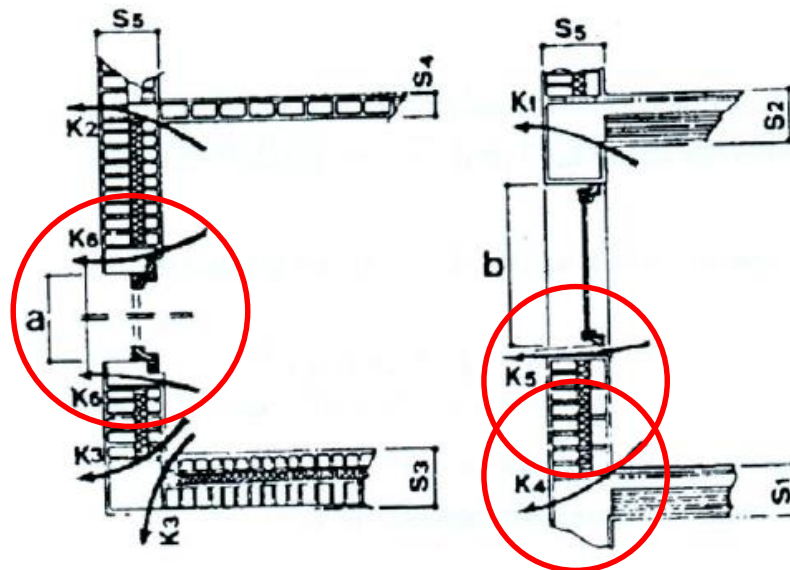

- horizontal joint between the floor and wall infill external (K4);
- sill of windows (K5);
- vertical kickbacks of the windows (K6).

Air conditioning plants in industrial environments

Calculation of thermal loads winter

c) *thermal bridges*

In the vicinity of a thermal bridge the isotherms have a trend of the type shown in the figure determined through a thermographic survey

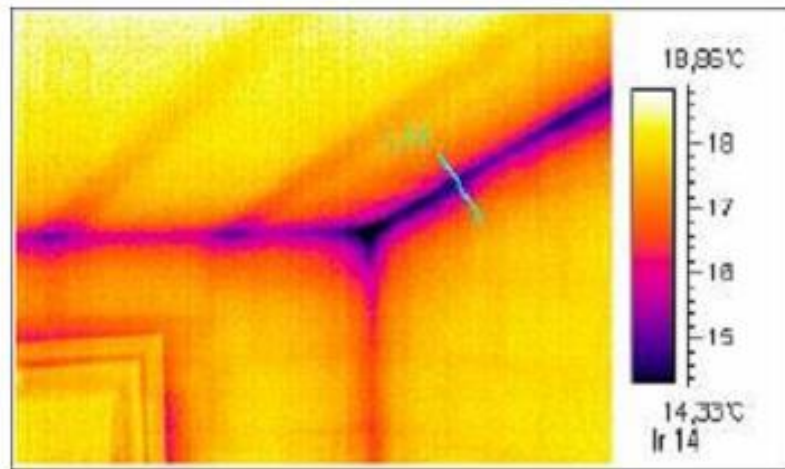

Internal thermal bridge to room (energy dispersion); visible also warping of the floor

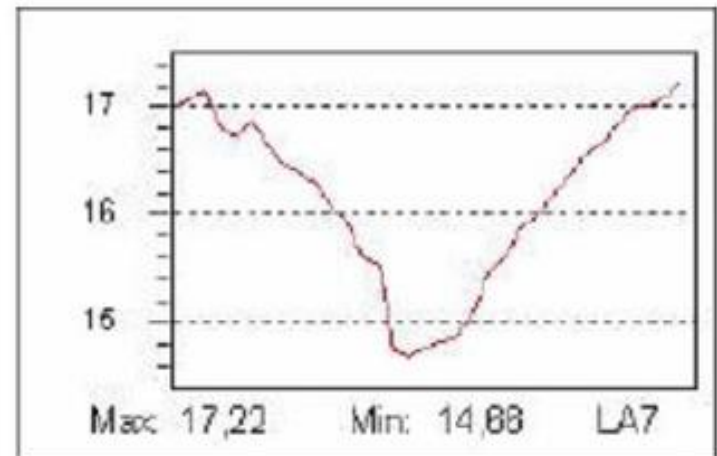

Diagram of the temperature through the blue line of the thermal bridge in the photo in the left

Air conditioning plants in industrial environments

Calculation of thermal loads winter

c) *thermal bridges*

The negative effects of thermal bridges are attributable to:

- reduction of the internal surface temperature of the discontinuity;
- increase in heat flow and heat loss. The thermal bridges can also triple the transmission of heat in a section of the building, although they represent only a small part of the surface itself;
- surface condensation. It occurs when the normal levels of relative humidity in indoor thermal comfort conditions combine with a surface temperature of the building which has a value lower than the dew point;
- formation of mold. It happens when you have a particular combination of temperature, vapor and substrate favorable. The most common types of fungi (molds) will mature in the presence of high humidity and low temperatures (0-15°C). A thermal bridge, due to the simultaneous presence of high relative humidity and low temperature, creates ideal conditions for the formation of mold;

Air conditioning plants in industrial environments

Calculation of thermal loads winter

c) *thermal bridges*

The negative effects of thermal bridges are attributable to:

- damage to the surface. The cyclical variations in surface temperature causes a sputter material of the structure. It was observed in 44% of cases like these surface damages are due to the presence of thermal bridges;
- decrease of thermal comfort. When the internal surface temperature of a part of the structure (wall, floor etc.) is lower by at least 2-3°C compared to the temperature of the environment, there is a feeling of discomfort in the vicinity of that surface. This effect is especially noticeable when the large areas are involved. A typical example is the junction area between a floor not isolated and the outer wall. To limit such discomfort generally raises the temperature of the environment thereby causing further loss of energy

Air conditioning plants in industrial environments

Calculation of thermal loads winter

c) *thermal bridges*

In the building structures the thermal bridges can be of two types:

- thermal bridges of form, which occur when the two outer walls forming an angle;
- thermal bridges of structure, which are located in correspondence at discontinuities caused by the insertion of elements having different thermal characteristics in the structure perimeter.

The overlap of the two types of thermal bridge enhances the negative effect (such as a pillar in the corner position).

Air conditioning plants in industrial environments

Calculation of thermal loads winter

c) *thermal bridges*

The figures show an example of correction of the thermal bridges

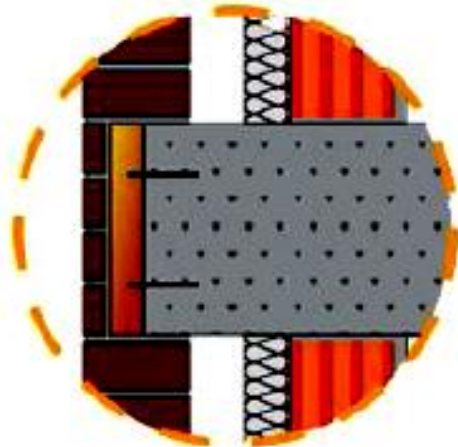

Application to mortar/with glue of strips of brick on multilayer boards of wool wood cement and anchored to the frame with metal brackets embedded in the jet

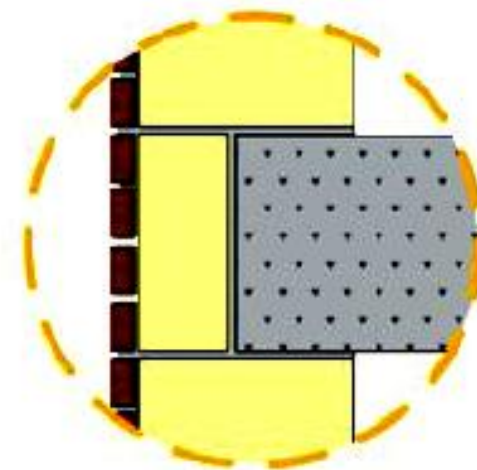

Application of strips of brick with adhesive on linear aered of concrete

Air conditioning plants in industrial environments

Calculation of thermal loads winter

c) *thermal bridges*

The figures show an example of correction of the thermal bridges

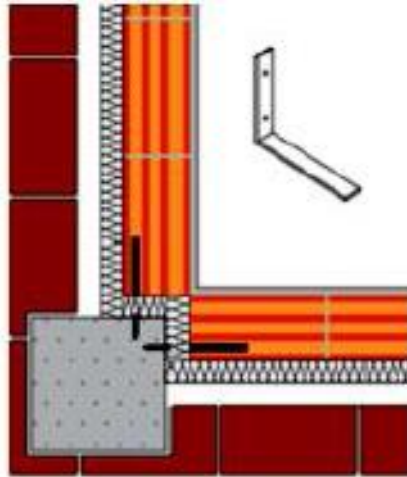

In the case of frame structures, the elimination of the thermal bridge on correspondence of the pillars can be obtained by isolation of the same on the inner side

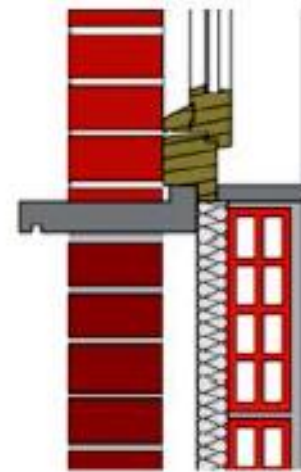

The thermal bridge in correspondence of the window sills can be effectively eliminated by interrupting the outer sill in correspondence of the insulating layer and placing a sill separated on the inner side

Air conditioning plants in industrial environments

Calculation of thermal loads winter

c) *thermal bridges*

The calculation of the heat flow of the thermal bridge can be done by following the procedure of UNI EN 12831: 2006, which introduces the transmission coefficient linear ψ (W/m K). This coefficient is:

- corner of two walls (insulation restarted in the walls)

$$\psi = 0,2 \cdot K \cdot s$$

where:

K = unitary transmittance of the wall (W/m² °C);

s = thickness of wall (m).

If the two walls are equal, K and s is treated as arithmetical mean values

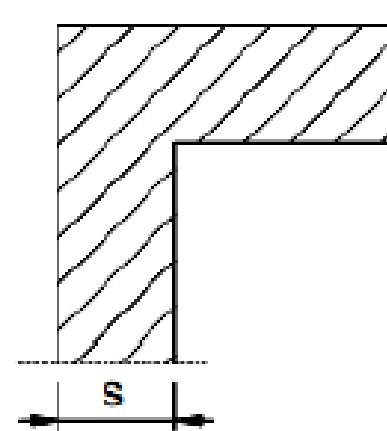

Air conditioning plants in industrial environments

Calculation of thermal loads winter

c) *thermal bridges*

The calculation of the heat flow of the thermal bridge can be done by following the procedure of UNI EN 12831: 2006, which introduces the transmission coefficient linear ψ (W/m K). This coefficient is:

- corner of two walls (pillar of angle in concrete)

$$\psi = 0,45 \cdot s$$

where:

s = thickness of the wall without insulation (m)

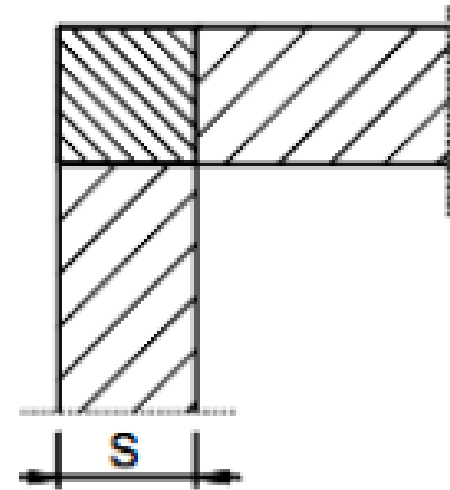

Air conditioning plants in industrial environments

Calculation of thermal loads winter

c) *thermal bridges*

The calculation of the heat flow of the thermal bridge can be done by following the procedure of UNI EN 12831: 2006, which introduces the transmission coefficient linear ψ (W/m K). This coefficient is:

- angle between two walls (insulation on the inside)

$$\psi = 0$$

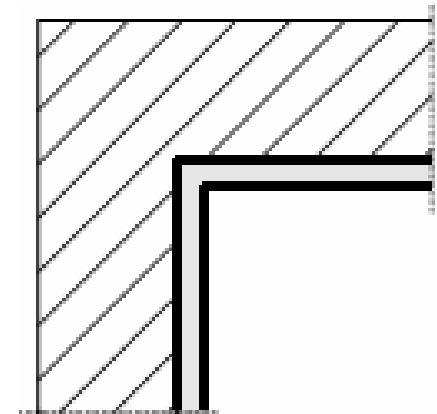

Air conditioning plants in industrial environments

Calculation of thermal loads winter

c) *thermal bridges*

The calculation of the heat flow of the thermal bridge can be done by following the procedure of UNI EN 12831: 2006, which introduces the transmission coefficient linear ψ (W/m K). This coefficient is:

- angle between two walls (insulation on the outer side)

$$\psi = 0,6 \cdot K \cdot s$$

where:

K = unitary transmittance of the wall (W/m² °C)

s = thickness of the wall without insulation (m)

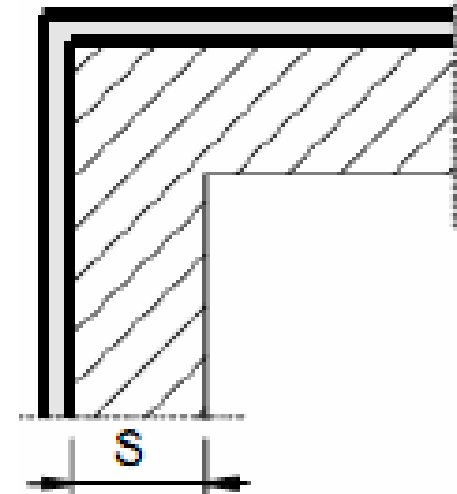

Air conditioning plants in industrial environments

Calculation of thermal loads winter

c) *thermal bridges*

The calculation of the heat flow of the thermal bridge can be done by following the procedure of UNI EN 12831: 2006, which introduces the transmission coefficient linear ψ (W/m K). This coefficient is:

- insulated wall with pillar (interruption of insulation inside at the wall)

where:
$$\psi = K \cdot L + (K - K_o) \cdot f(y)$$

K = unitary transmittance of uninsulated wall (W/m² °C);

K_o = unitary transmittance of insulated wall (W/m² °C);

L = stroke of width is not isolated (corresponding to the pillar) (m);

$f(y) = 0,26 \cdot y^2 + 0,31 \cdot y + 0,02$ with:

$$y = \frac{s_i}{(s_i + s_e)}$$

with s_i and s_e the thickness of the inner and outer wall at intermediate isolation

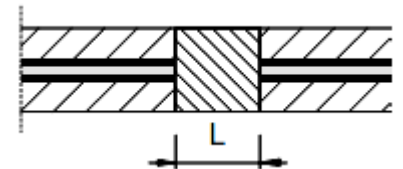

Air conditioning plants in industrial environments

Calculation of thermal loads winter

c) *thermal bridges*

The calculation of the heat flow of the thermal bridge can be done by following the procedure of UNI EN 12831: 2006, which introduces the transmission coefficient linear ψ (W/m K). This coefficient is:

- insulated wall with pillar (without interruption of insulation put outside)

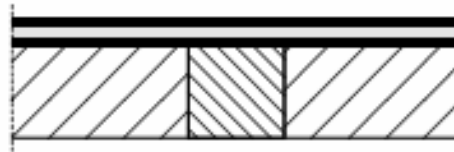

$$\psi = 0$$

Air conditioning plants in industrial environments

Calculation of thermal loads winter

c) thermal bridges

The calculation of the heat flow of the thermal bridge can be done by following the procedure of UNI EN 12831: 2006, which introduces the transmission coefficient linear ψ (W/m K). This coefficient is:

- joint of external wall with the inner wall (external wall insulation to be restarted)

$$\psi = 0,4 \cdot K \cdot s$$

where:

K = unitary transmittance of wall fictitious placed in correspondence of the inner wall and bounded by traits dashed (W/m² °C);

s = thickness of the inner wall;

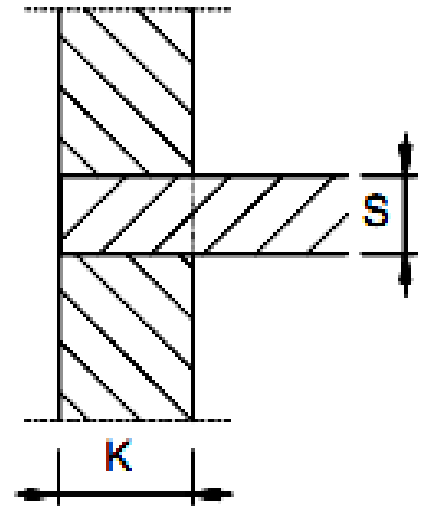

Air conditioning plants in industrial environments

Calculation of thermal loads winter

c) *thermal bridges*

The calculation of the heat flow of the thermal bridge can be done by following the procedure of UNI EN 12831: 2006, which introduces the transmission coefficient linear ψ (W/m K). This coefficient is:

- joint external wall with the inner wall (wall insulated externally)

$$\psi = 0$$

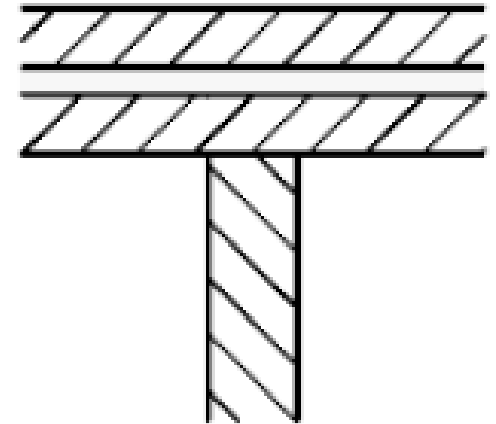

Air conditioning plants in industrial environments

Calculation of thermal loads winter

c) *thermal bridges*

The calculation of the heat flow of the thermal bridge can be done by following the procedure of UNI EN 12831: 2006, which introduces the transmission coefficient linear ψ (W/m K). This coefficient is:

- joint of external wall with the inner wall (external wall insulation to be restarted)

$$\psi = 0,4 \cdot K \cdot L + 0,4 \cdot (K - K_o) \cdot f(y)$$

where:

K = unitary transmittance of uninsulated wall (W/m² °C)

K_o = unitary transmittance of insulated wall (W/m² °C);

L = stroke of width is not isolated (corresponding to the pillar) (m);

$f(y) = 0,26 \cdot y^2 + 0,31 \cdot y + 0,02$ with: $y = \frac{s_i}{(s_i + s_e)}$

with s_i and s_e the thickness of the inner and outer wall at intermediate isolation

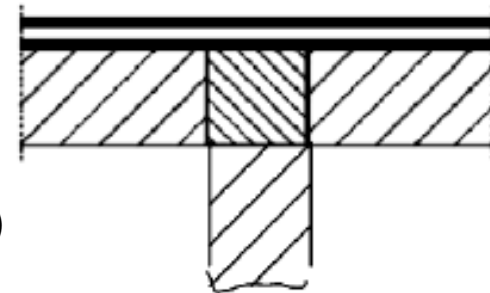

Air conditioning plants in industrial environments

Calculation of thermal loads winter

c) *thermal bridge*

The calculation of the heat flow of the thermal bridge can be done by following the procedure of UNI EN 12831: 2006, which introduces the transmission coefficient linear ψ (W/m K). This coefficient is:

- joint external wall of window (the insulation is linear and continues with the joint)

$$\psi = 0$$

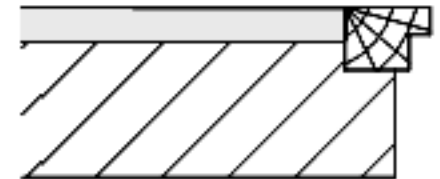

Air conditioning plants in industrial environments

Calculation of thermal loads winter

c) thermal bridge

The calculation of the heat flow of the thermal bridge can be done by following the procedure of UNI EN 12831: 2006, which introduces the transmission coefficient linear ψ (W/m K). This coefficient is:

- joint external wall of window (insulation forms an L with the joint)

$$\psi = 0,6 \cdot K \cdot s$$

where:

K = unitary transmittance of insulated wall (W/m² °C)

s = thickness of the inner wall (m)



Air conditioning plants in industrial environments

Calculation of thermal loads winter

c) *thermal bridges*

The calculation of the heat flow of the thermal bridge can be done by following the procedure of UNI EN 12831: 2006, which introduces the transmission coefficient linear ψ (W/m K). This coefficient is:

- joint external wall of window (the insulation is linear, but from the opposite side of the joint)

$$\psi = \frac{0,6 \cdot s}{0,06 + R_m}$$

where:

R_m = thermal resistance specific of the wall of wall uninsulated ($\text{m}^2 \text{ } ^\circ\text{C/W}$)

s = thickness of the wall without insulation (m)

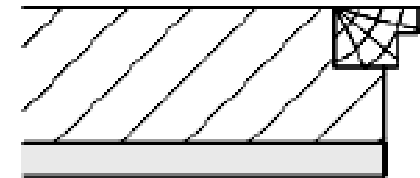

Air conditioning plants in industrial environments

Calculation of thermal loads winter

c) *thermal bridges*

Determined the value of the transmission coefficient linear, the heat flow through the thermal bridge is calculated by multiplying this coefficient for the length of the thermal bridge.

The flow of heat through a wall $Q_{d,parete}$ with temperature difference of 1°C , it is provided by the relationship :

$$Q_{d,parete} = \sum_{j=1}^n (K \cdot S)_j + \sum_{j=1}^n (\psi \cdot L)_j$$

where:

K = thermal transmittance of the wall ($\text{W}/\text{m}^2 \text{ }^\circ\text{C}$);

S = area of the wall (m^2);

ψ = transmittance linear ($\text{W}/\text{m } ^\circ\text{C}$);

L = length of each joint (m).

The second term takes into account the presence of thermal bridges.

Air conditioning plants in industrial environments

Calculation of thermal loads winter

c) thermal bridge

In the case of a corner between two walls (figure), the thermal power dispersed Q_{totale} is the following:

$$Q_{\text{totale}} = K_1 \cdot S_1 \cdot \Delta t + K_2 \cdot S_2 \cdot \Delta T + 2 \cdot \psi \cdot \Delta t$$

where:

K_1, K_2 = thermal transmittance of the two walls
($\text{W}/\text{m}^2 \text{ } ^\circ\text{C}$);

S_1, S_2 = surfaces of the two walls (m^2);

$\Delta t, \Delta T$ = difference between the indoor and
outdoor temperature ($^\circ\text{C}$);

ψ = transmittance linear ($\text{W}/\text{m } ^\circ\text{C}$).

In the calculations, the transmission of heat through the thermal bridges is calculated separately from the transmission of heat through the plain structures

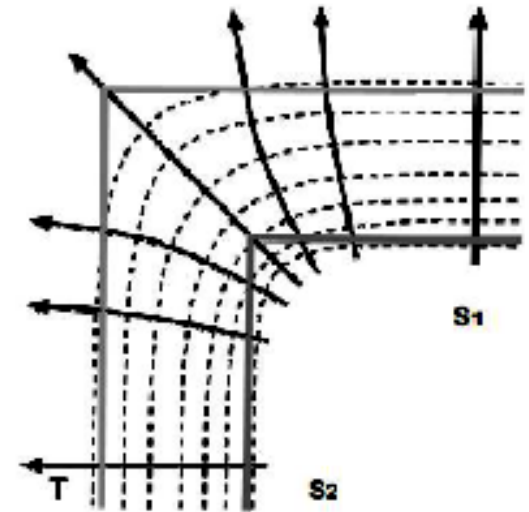

Air conditioning plants in industrial environments

Calculation of thermal loads winter

c) *thermal bridges*

Very often it is too costly and unwieldy a calculation of the value of the coefficient lineico as presented above (be noted that the contribution due to thermal bridges is much lower than that of opaque elements such as walls, ceilings or floors).

For this reason, the ISO / DIS 14683 has summarized in the tables, the most common situations encountered in practical cases. The following is a diagram of a possible building and tables encoded with the different types of thermal bridges.

Air conditioning plants in industrial environments

Calculation of thermal loads winter

c) *thermal bridges*

It should be noted that only ψ_i must be used in the case of internal net length of the room, ψ_{oi} in the case of gross internal dimension (considering the interior rear-end collisions) and ψ_e in the case of size measured to outside

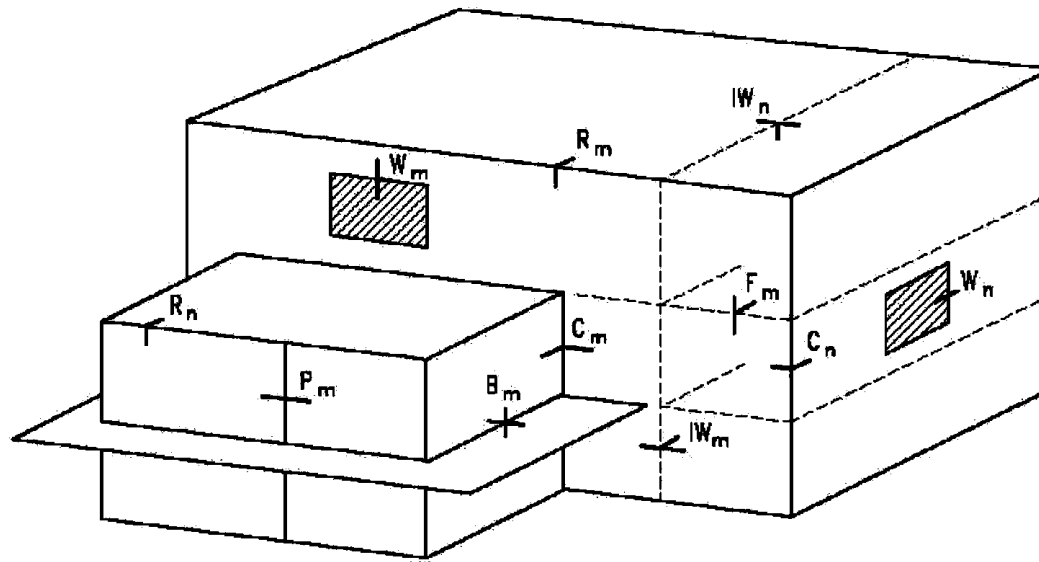

Air conditioning plants in industrial environments

Calculation of thermal loads winter

c) *thermal bridges*

In case it is required to obtain the precise value of dispersion of special thermal bridges do not exist among those described above, it is necessary to solve the differential equation (which may present more dimensions), which describes the heat flow between the two sources at different temperatures.

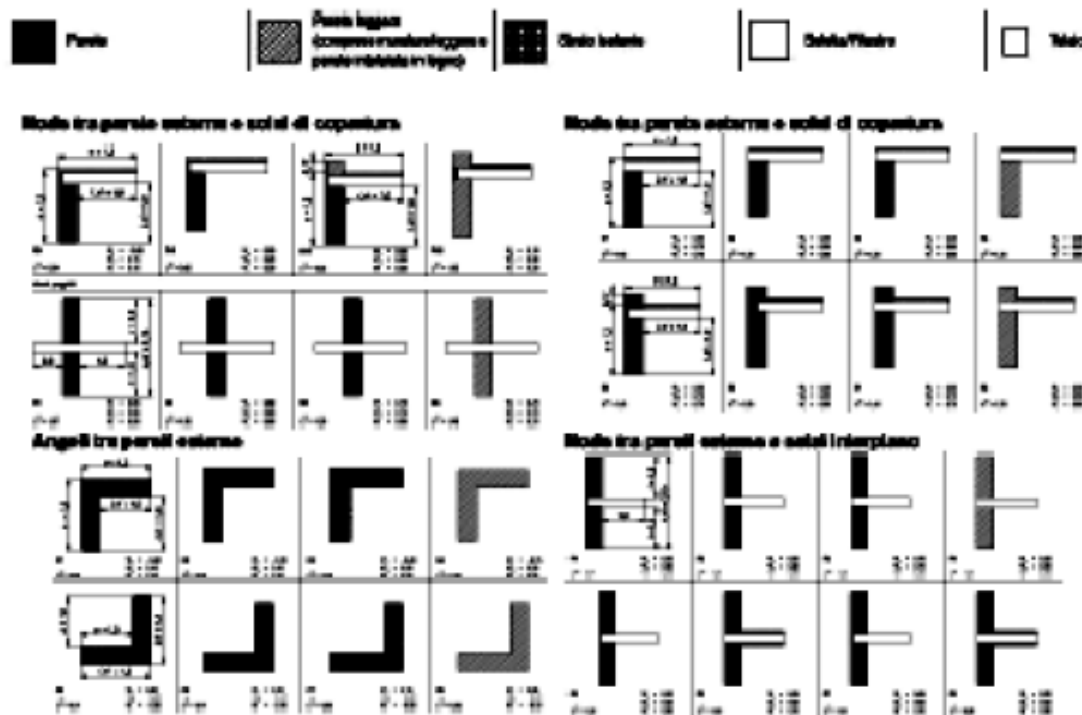

Air conditioning plants in industrial environments

Calculation of thermal loads winter

c) *thermal bridges*



There are many different software that solve the problem using the finite element method

Air conditioning plants in industrial environments

Calculation of thermal loads winter

d) calculation of the thermal power dispersed for transmission

The calculation of the thermal power Q_d dispersed by individual rooms or the entire building is performed by adding the dispersion of individual structural components involved:

$$Q_d = Q_{ds} + Q_{dl} \quad [\text{W}]$$

where:

Q_{ds} = total dispersion of all components of the unit building surface structures considered (environment, building)

Q_{dl} = the total heat loss of all thermal bridges in the unit building considered

Air conditioning plants in industrial environments

Calculation of thermal loads winter

e) *checking the insulation characteristics of the building as a whole*

The Law n. 10/91 and Presidential Decree n. 412/93 divides the Italian territory into six climatic zones as a function of degree-days (DD - °C day/year), regardless of geographic location

The six areas are:

- zone A: Municipalities with GG number of not more than 600;
- zone B: Municipalities with the number of GG > 600 and not more than 900;
- zone C: Common with the number of GG > 900 and not exceeding 1400;
- zone D: Municipalities with the number of GG > 1400 and not exceeding 2100;
- zone E: Municipalities with the number of GG > 2100 and not exceeding 3000;
- zona F: Comuni con numero di GG > 3000.

Air conditioning plants in industrial environments

Calculation of thermal loads winter

e) *checking the insulation characteristics of the building as a whole*

The GG is the sum, extended to all days of an annual period of conventional heating N, the only differences positive between daily temperature conventional internal reference T_i , set in Italy at 20°C, and the average outside temperature daily T_{em} (figure)

$$GG = \sum_{j=1}^N (T_i - T_{em,j}) \quad \text{con } T_{em,j} \leq T_i$$

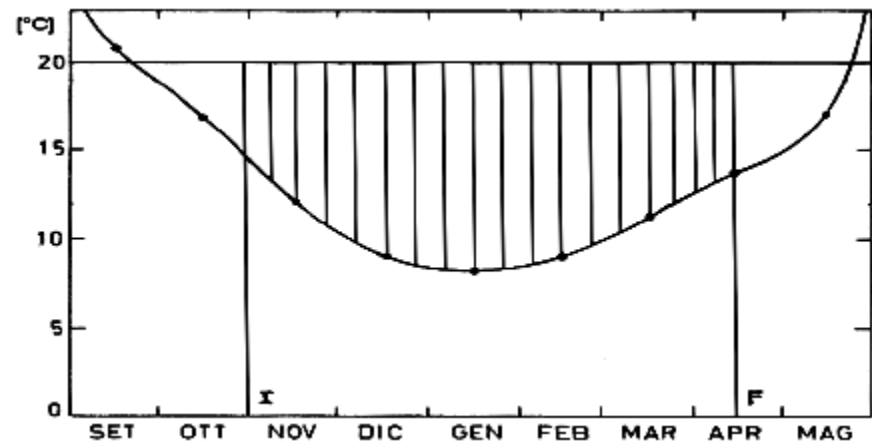

Air conditioning plants in industrial environments

Calculation of thermal loads winter

e) *checking the insulation characteristics of the building as a whole*

A low value of GG indicates a short warm-up period and average daily temperatures next to the temperature set for the environment. In contrast, high values of heating degree days, indicating prolonged periods of heating and average daily temperatures much lower than the conventional temperature of reference.

Air conditioning plants in industrial environments

Calculation of thermal loads winter

e) checking the insulation characteristics of the building as a whole

GG and the conventional duration of the heating period for Municipalities

Municipality	Province	Altitude (m)	Degree days (°C giorno/anno)	Duration of the heating period
Casarsa della Delizia	Pordenone	44	2495	15 october – 15 april for 14 hours/day (zone E)
Gorizia	Gorizia	84	2333	15 october – 15 april for 14 hours/day (zone E)
Monfalcone	Gorizia	7	2213	15 october – 15 april for 14 hours/day (zone E)
Muggia	Trieste	3	1929	1 november – 15 april for 12 hours/day (zone D)
Palmanova	Udine	27	2438	15 october – 15 april for 14 hours/day (zone E)
Pordenone	Pordenone	27	2438	15 october – 15 april for 14 hours/day (zone E)
Trieste	Trieste	2	1929	1 november – 15 april for 12 hours/day (zone D)
Tolmezzo	Udine	323	3036	no restriction (between 5 am and 23 pm each day (zone F)
Udine	Udine	113	2323	15 october – 15 april for 14 hours/day (zone E)

Air conditioning plants in industrial environments

Calculation of thermal loads winter

e) *checking the insulation characteristics of the building as a whole*

La legge n. 10/91 si è posta l'obiettivo di risparmio energetico negli edifici non solo attraverso l'isolamento, ma anche aumentando l'efficienza dei sistemi e l'uso di fonti energetiche alternative, e di introdurre la certificazione energetica

Air conditioning plants in industrial environments

Calculation of thermal loads winter

e) *checking the insulation characteristics of the building as a whole*

Energy certification is not mandatory for:

- industrial buildings, craft and non-residential agricultural environments when they are kept at a controlled temperature or air-conditioned for the needs of the production process, are also excluded agricultural and industrial buildings craft and related appurtenances if the rooms are kept at a controlled temperature or air-conditioned using waste energy manufacturing process not otherwise usable;
- isolated buildings with a total useful floor area of less than 50 m²;
- systems installed for the purpose of manufacturing process carried out in the building, even when used, in part non dominant, for typical uses of the civil sector.

Air conditioning plants in industrial environments

Calculation of thermal loads winter

e) *checking the insulation characteristics of the building as a whole*

The figure shows an example of energy certification of buildings and the results achieved from the comparison that allow you to say that the second apartment save € 1,900.00 per year.

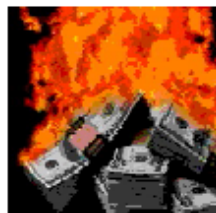
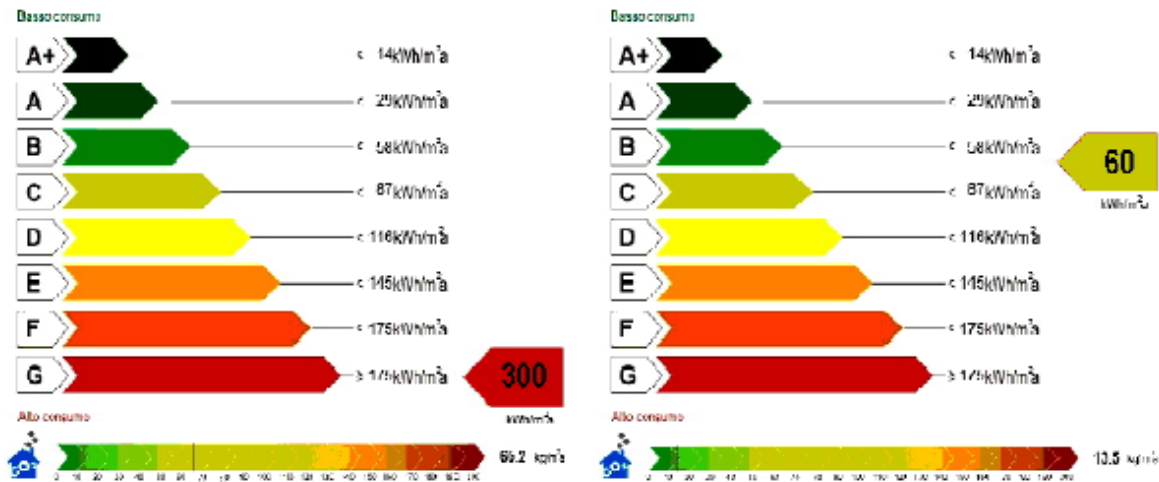

Natural gas fuel
apartment 120 m²
Spend 2.380 €/year



Natural gas fuel
apartment 120 m²
Spend 475 €/year

Air conditioning plants in industrial environments

Calculation of thermal loads winter

e) *checking the insulation characteristics of the building as a whole*

The decree law n. 10/91 (DPR 412/93, which is coordinated by the Ministerial Decree 08/06/94, by Presidential Decree 551/99, Law 01/03/2002 n. 39, with the DM 17.03.2003 and with the Legislative Decree 192/05) sets the verification of the volume coefficient of dispersion C_d , which must be less than the limit $C_d \text{ limite}$ and must refer specifically to the UNI EN 12831: 2006. It also sets out to verify the energy consumption normalized FEM and the overall performance of the average seasonal η_g .

Air conditioning plants in industrial environments

Calculation of thermal loads winter

e) *checking the insulation characteristics of the building as a whole*

The volume coefficient of dispersion C_d is expressed by the relation:

$$C_d = \frac{Q_d}{V \cdot (T_i - T_e)} \quad (\text{W/m}^3 \text{ } ^\circ\text{C})$$

where:

Q_d = thermal power dispersed through the walls, without counting the ventilation (W);

V = gross heated volume of the building (m^3);

T_i = internal air temperature ($^\circ\text{C}$);

T_e = external air temperature ($^\circ\text{C}$).

Air conditioning plants in industrial environments

Calculation of thermal loads winter

e) *checking the insulation characteristics of the building as a whole*

The coefficient C_d depends directly on the degree of insulation of the building and is a function of the climate zone where the building is made and of the form factor defined by the relation:

$$\text{Form factor} = S_d/V \text{ (1/m)}$$

where:

S_d = outer surface dispersant total for the entire building (m^2);

V = gross volume for the entire building (m^3).

Air conditioning plants in industrial environments

Calculation of thermal loads winter

e) *checking the insulation characteristics of the building as a whole*

The design value of C_d should always be less than a $C_{d,limite}$, that the D.I. 30/07/1986 imposes a function of the site (climate zone and degree day - GG) and the geometric ratio S/V between the surface and dispersing the heated volume, as shown in Table

S/V	Climatic zone									
	A	B		C		D		E		F
	GG	GG		GG		GG		GG		GG
	< 600	601	900	901	1400	1401	2100	2101	3000	>3000
<0,2	0,49	0,49	0,46	0,46	0,42	0,42	0,34	0,34	0,30	0,30
>0,9	1,16	1,16	1,08	1,08	0,95	0,95	0,78	0,78	0,73	0,73

Air conditioning plants in industrial environments

Calculation of thermal loads winter

e) *checking the insulation characteristics of the building as a whole*

Therefore determined the value of degree days relative to the City will be built where the industrial activity and identified the climatic zone, it is possible to determine the two limit values of the thermal power dispersed $C_{d,limite}$ bound for the two values of S/V of 0.2 and 0.9 ($C_{d,limite,1}$ and $C_{d,limite,2}$). From these two values, it is possible to identify the threshold value for the building for that value of S/V , which is equal to ($W/m^3 \text{ } ^\circ C$):

$$C_{d,limite} = C_{d,limite,1} + \frac{\frac{S}{V} - 0,2}{0,7} \cdot (C_{d,limite,2} - C_{d,limite,1})$$

The building as a whole will be isolated if it is checked in accordance with the report:

$$C_d < C_{d,limite}$$

Air conditioning plants in industrial environments

Calculation of thermal loads winter

f) checking the insulation characteristics of the individual environments

To avoid that the thermal insulation is performed in a non-uniform and to ensure the well-being in the most exposed, the D.I. 30.07.1986 has set the maximum limits allowed the $C_{d,a}$ for environments ($C_{d,limite,a}$) with the same quality standards set out for the building as a whole, notwithstanding the positive verification of the latter.

Because there is no way bound by a rule, the methodology used for testing is as follows:

- calculate the ratio of the shape of the S_L/V_L where S_L is the surface of the sun dispersing walls, that is facing towards the outside or in unheated rooms (m^2) and V_L is the net volume of the environment measured within the surface that delimits (m^3);

Air conditioning plants in industrial environments

Calculation of thermal loads winter

f) checking the insulation characteristics of the individual environments

Because there is no way bound by a rule, the methodology used for testing is as follows:

- one determines the $C_{d,limite,a}$ maximum allowable for the environments through the form factor and the climate zone (table). For the values of S/V of less than 0.4 and greater than 1 will adopt the values of the extreme, respectively, upper and lower

Form factor S/V	Degree days				
	Up to 900	901-1400	1401-2100	2101-3000	Over 3000
0,4	0,93	0,83	0,71	0,59	0,50
0,5	1,16	1,03	0,88	0,74	0,62
0,6	1,40	1,23	1,06	0,89	0,74
0,7	1,63	1,44	1,23	1,05	0,87
0,8	1,86	1,65	1,41	1,19	0,99
0,9	2,09	1,86	1,59	1,34	1,12
1,0	2,33	2,07	1,77	1,49	1,24

Air conditioning plants in industrial environments

Calculation of thermal loads winter

f) checking the insulation characteristics of the individual environments

Because there is no way bound by a rule, the methodology used for testing is as follows:

- we calculate the real value of the thermal power scattered by single structures under consideration per unit volume and of temperature:

$$C_{d,a} = \frac{Q_{d,a}}{V_a \cdot (T_i - T_e)} \quad (\text{W/m}^3 \text{ } ^\circ\text{C})$$

with:

$Q_{d,a}$ = heat loss of the structures of the environment;

V_a = volume of the environment;

- the environment is in accordance if it is verifies the report:

$$C_{d,a} < C_{d,\text{limite},a}$$

Air conditioning plants in industrial environments

Calculation of thermal loads winter

g) heat losses due to ventilation and calculation of the thermal power for air exchange and relative verification of law

To ensure the quality of air in an industrial environment is necessary to ensure that there is adequate air exchange in relation to the intended use of the local analyzed, taking into account that the shell of the building is not impervious to air, but it is crossed by a non-negligible air flow that give significant contributions to the energy balance.

The **human sense of well-being thermohygrometric** in civil environments and work depends mainly on temperature, relative humidity, air velocity, radiant heat energy, physical activity, clothing and related thermal insulation of the same. There are other factors that affect the well-being such as: noise, light, air quality (gas content is different in quality and in quantity to those of pure air) and so on.

Air conditioning plants in industrial environments

Calculation of thermal loads winter

g) heat losses due to ventilation and calculation of the thermal power for air exchange and relative verification of law

It is for this reason that in the design imposes to adopt a flow of air coming from outside, which is expressed as "number of renewal per hour of the volume of the environment".

This does not correlate to the phenomenon of air infiltration through the envelope and natural ventilation to the microclimate inside and outside, but it is useful if you want to impose a limit on the exchange of air to save energy and to ensure interior comfort.

Air conditioning plants in industrial environments

Calculation of thermal loads winter

g) heat losses due to ventilation and calculation of the thermal power for air exchange and relative verification of law

During the winter the fresh air into the room from a ventilation system or for infiltration and natural ventilation must be heated from the outside temperature to the internal temperature of the room t_i . The amount of heat required to heat the fresh air is given by the relation:

$$Q_v = C_{sv} \cdot n \cdot V \cdot (T_i - T_e)$$

where:

C_{sv} = specific heat of air (0,35 W h/m³ °C);

n = number of times in which the volume V of the air is renewed in an hour or number of parts per hour or ventilation rate (1/h);

V = the gross volume of the heated parts of the building, defined by the outer surfaces of the elements that surround it (m³);

$(T_i - T_e)$ = difference between temperature inner and outer (°C).

Air conditioning plants in industrial environments

Calculation of thermal loads winter

g) heat losses due to ventilation and calculation of the thermal power for air exchange and relative verification of law

The value of the number of air changes per hour varies depending on the activities carried out within the building/premises and in any case proportional to crowding. The following table shows the values for the air changes per hour for some intended uses and the minimum flow required

Destination of use of premises	Renewal of air per hour n (volume of environment/h)	Minimum flows (dm ³ /s person)
Offices	1,5 – 2,5	10
Commercial buildings	1 – 2	8
.....

Air conditioning plants in industrial environments

Calculation of thermal loads winter

h) increases be made to the thermal dispersions

For the definition of the heat demand of a building, the UNI EN 12831: 2006 provides for increases to be taken into account in the calculation of losses due to exposure and intermittency of operation

Air conditioning plants in industrial environments

Calculation of thermal loads winter

h) increases be made to the thermal dispersions

- corrections for exposure

These corrections take account of direct solar radiation, different degree of humidity of walls and different speed and temperature of the winds. The values of the increase coefficient, which takes into account the orientation of the surface are shown in the table and are applied to the dispersions to run through the structures and to the dispersions due to thermal bridges

S	S-O	O	N-O	N	N-E	E	S-E
1,00	1,05	1,10	1,15	1,20	1,20	1,15	1,10

Air conditioning plants in industrial environments

Calculation of thermal loads winter

h) increases be made to the thermal dispersions

- increases due to intermittency of operation

In the calculation of the overall heat loss of the building should take into account a correction factor due to attenuation of the nocturnal heating or intermittent operation of the heating system. The values of the increases are reported in the table and apply to the sum total of the dispersions, including those for ventilation or air exchange (values in %)

Operation	Plants at hot air	Plants of radiators	Plants at pannels
Continuous with attenuation nightttime	12	8	5
With daily use of 16-18 hours	15	10	8
With daily use of 12-16 hours	20	12	10
With daily use of 8-12 hours	25	15	12
With daily use of 6-8 hours	30	20	15
With daily use of 4-6 hours	35	25	20

Air conditioning plants in industrial environments

Evaluation the normalized energy needs

The UNI allows you to calculate the energy needs in a simplified form, which is therefore conventional, although it is fairly close to reality with deviations of the order of 20%. The deviation will be higher the more different are the conditions of use the building with respect the procedure.

Air conditioning plants in industrial environments

Evaluation the normalized energy needs

The normalized energy needs for heating winter FEN, introduced in the DPR 412/93, is defined in the UNI/TS 11300: 2008 from:

$$FEN = \frac{Q}{V \cdot N \cdot (\theta_i - \theta_{em})} \quad (\text{J/m}^3 \text{ GG})$$

where:

Q = demand for primary energy needed for heating throughout the season (J);

V = gross volume of the building of the structures in the position of the building and heated space bounded by a single plant (m³);

N = number of days per year of heating fixed by decree (days);

θ_i = internal temperature of project of individual building premises (°C);

θ_{em} = seasonal average outside air temperature (°C), defined by the ratio between the degrees day and the duration of heating

Air conditioning plants in industrial environments

Evaluation the normalized energy needs

The FEN is thus a parameter that allows you to compare the buildings from the point of view of consumption for heating, regardless of their volume and climate from which they are subject.

If the building has only one heating system, you have to calculate a single FEN.

Air conditioning plants in industrial environments

Evaluation the normalized energy needs

The primary energy for heating Q is the energy relative to all the consumption of fuel required for heating in a year (average from the climate point of view)

$$Q = Q_c + \frac{Q_{aux}}{\eta_{sen}}$$

where:

Q_c = energy associated with the fuel burned in the heat generator (primary energy) in the period considered;

Q_{aux} = electrical power for auxiliaries (pumps, fans, etc.) during the period. It is smaller than Q_c for radiator systems and underfloor heating (1-2%), while it may be significant for fan coil systems for heating and air);

η_{sen} = efficiency of the national electricity service, the fixed norm of 0.36. It takes into account the conversion of fuel energy to electrical energy.

Air conditioning plants in industrial environments

Evaluation the normalized energy needs

The ratio Q_{aux}/η_{sen} is the primary energy corresponding to the electric energy consumption of the auxiliaries.

Q_c is the energy consumed in the heat generator (boiler) in the period under review and may be defined by performing an energy balance on the same heat generator:

$$Q_c + Q_p + Q_b = Q_d + Q_f + Q_u$$

where:

Q_c = energy associated with the fuel burned in the heat generator (primary energy);

Q_p = electrical energy supplied to the circulation pump of the heat transfer fluid;

Q_b = electrical energy supplied to the burner;

Q_d = dispersed energy through the mantle of the heat generator;

Q_f = energy due to losses in the smokes or at chimney;

Q_u = useful thermal energy supplied by the generator to the user.

Air conditioning plants in industrial environments

Evaluation the normalized energy needs

It 's reported a diagram that shows the amount sun heat into play in the equation just presented

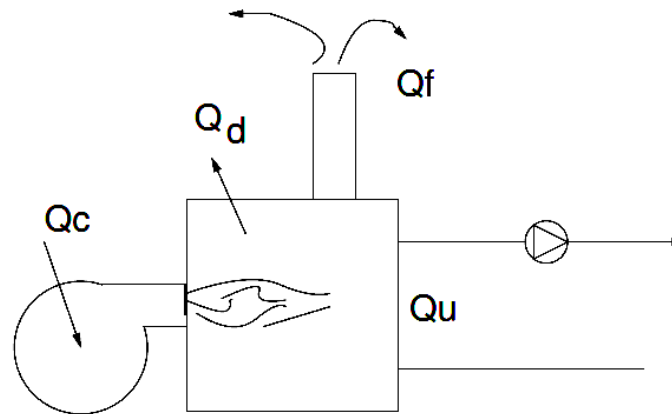

Air conditioning plants in industrial environments

Evaluation the normalized energy needs

The useful energy produced Q_u , if is reduced by the contribution of energy supplied to the pump $Q_{p,.}$ provides the energy that actually serves the user to heat the building Q_e . To solve the budget you need to know the useful energy produced by the generator heat Q_u , term that is calculated from the energy demands of the users, who qualifies with the building, under conditions of ideal system Q_h taking into account the inefficiencies of the system in transferring the energy from the heat generator to the environments to be heated.

Air conditioning plants in industrial environments

Evaluation the normalized energy needs

The norm UNI/TS 11300-1: 2008 provides three different ways to perform this calculation:

- a) semi-stationary method, where the energy required is the sum of the monthly contributions on the assumption of stationarity of the conditions within individual months. In this case it is assumed that the steady state in the month and variable from month to month during the heating season. This method can be used for any type of building;
- b) stationary method A, where the useful energy produced by the generator heat Q_u is a seasonal average. The method is applicable with volume less than 10,000 m³;

Air conditioning plants in industrial environments

Evaluation the normalized energy needs

The norm UNI/TS 11300-1: 2008 provides three different ways to perform this calculation:

- c) stationary method B, where the useful energy produced by the generator heat Q_u is a seasonal average, but the demand calculation is done considering only losses without taking into account the free contributions which are instead considered in the first two methods. This method applies with volume less than $10,000 \text{ m}^3$ and with reduced intake of energy from the sun.

Air conditioning plants in industrial environments

Evaluation the normalized energy needs

To calculate the ideal requirements of energy Q_h , the environments are grouped according to how they are heated and therefore we define:

- thermal zone, date by the part of the building in which there is uniformity of the temperature, free contributions and all the parameters that are part of the calculation of the ideal requirement of energy for heating;
- building, which is a set of all thermal zones to be heated with a unique heating system. Very often the building does not correspond to the building, as in the case of most buildings served by a same thermal power as in the case of district heating.

Air conditioning plants in industrial environments

Evaluation the normalized energy needs

The ideal energy requirements for heating Q_h is calculated for each thermal zone served by the plant. The requirement of the building is calculated as the sum of the contributions of the individual zones, as it is not possible to have uniformity of presentation climate, intended use and distribution of the various building premises.

To changing external conditions (for only a few days a year to reach the design temperature), the heating system has to maintain cost internal conditions (temperature). For the calculation of consumption, are estimated the exchanges with the outside equaling the contribution of the heating system to the difference between the energies dispersed and those available from other sources or free heating purposes.

Air conditioning plants in industrial environments

Evaluation the normalized energy needs

Knowing the value of energy use in ideal conditions Q_h (will be explained later how to define this value) for a thermal zone, to maintain the internal conditions you want to have to go back to the energy that must be supplied by the heat generator to meet the needs of the user Q_u then determine the primary energy consumed by the generator Q_c .

Air conditioning plants in industrial environments

Evaluation the normalized energy needs

To do this you must take into account the inefficiencies in the system of transfer of energy from the generator to the environment and then determine the energy to be supplied to the thermal zone in real conditions Q_r , defined by the relation:

$$Q_r = \frac{Q_h}{\eta_e \cdot \eta_c}$$

where: Q_h = ideal requirement of energy for heating;

η_e = emission efficiency, which takes into account the inefficiencies in energy transfer from the terminal end of the environment (eg increased losses due to the rising of the temperature of the back of the radiator). The typical value is 0.95;

η_c = regulating or control efficiency, which takes into account the characteristics of the adjustment system that can bring the internal temperature to higher values than those of the reference in the design calculations and entail further dispersions (for example non-uniformity of temperature between the room thermo stated and those not thermo stated). The typical value is around 0.9.

Air conditioning plants in industrial environments

Evaluation the normalized energy needs

It must also take into account the losses along the distribution network from the heating to the thermal zones, we can calculate the thermal energy from the outgoing unit itself Q_u during the reporting period as the sum of the contributions to the different thermal zones served $Q_{r,i}$ divided by the the distribution efficiency η_d , which is a function of the dispersions due to distribution (value around 0.9):

$$Q_u = \frac{\sum_{i=1}^m Q_{r,i}}{\eta_d}$$

Air conditioning plants in industrial environments

Evaluation the normalized energy needs

The calculation methods and the recommended values of efficiency are reported in the UNI/TS 11300-2: 2008, EN 15316-1: 2008 and EN 15316-2-1: 2008.

The thermal energy produced necessary Q_n for the user to transfer his request Q_u during the period must take account of the electricity consumed by the circulation pump Q_p and efficiency of this operator machine η_p :

$$Q_n = Q_u + Q_p \cdot \eta_p$$

The contribution of the term $Q_p \cdot \eta_p$ is very small order of 1%.

Air conditioning plants in industrial environments

Evaluation the normalized energy needs

From the thermal energy produced Q_n during the period considered is possible to obtain the primary energy consumed Q_c that is equal to:

$$Q_c = \frac{Q_u}{\eta_{tu}} = \frac{Q_h}{\eta_{tu} \cdot \eta_e \cdot \eta_c \cdot \eta_d}$$

where: η_{tu} = thermal efficiency of the heat generator, which represents its average efficiency in the time period (month or semi-stationary method for the season in the stationary method) and that depends on the type of generator and how it is being used.

Air conditioning plants in industrial environments

Evaluation the normalized energy needs

η_{tu} = thermal efficiency of the heat generator depends on:

- load factor useful C_p that is < 1 (increases η_{tu} with increasing C_p which has as its maximum value 1 and which is expressed by the relation:

$$C_p = \frac{Q_n}{Q_{nN}} = \frac{Q_n}{Q_N \cdot t_a \cdot N}$$

where: Q_n = thermal energy produced needed to transfer at the user its request; Q_N = nominal power of heat generator; t_a = time to ignition of the thermal generator in a day; N = number of days in the period when the ignition assessing the ideal needs of energy Q_h .

- loss in the flue gas;
- loss along the mantle of the heat generator;
- losses in the flue gas to the burner closed.

Air conditioning plants in industrial environments

Evaluation the normalized energy needs

Knowing the value of the primary energy consumed Q_c , one can determine the demand for primary energy needed for heating throughout the season Q through the relation above view:

$$Q = Q_c + \frac{Q_{aux}}{\eta_{sen}} = Q_c + \frac{Q_p + Q_b}{\eta_{sen}}$$

where: Q_c = energia associata al combustibile bruciato nel generatore di calore (energia primaria);

Q_{aux} = electrical power for auxiliaries (pumps, fans, etc.). Is smaller than Q_c for radiator systems and underfloor heating (1-2%), while it may be significant for fan coil systems for heating and air);

η_{sen} = efficiency of the National Electricity Service, the fixed norm of 0.36. It takes into account the conversion of fuel energy to electrical energy.

Q_p = electrical energy supplied to the circulation pump of the heat transfer fluid;

Q_b = electricity supplied to the burner.

Air conditioning plants in industrial environments

Evaluation the normalized energy needs

The formula of ideal requirement of energy Q_h for installations in continuous operation 24 hours a day during the period is as follows:

$$Q_h = (Q_L - Q_{ai}) - \eta_u \cdot (Q_{ae} + Q_a)$$

where: Q_L = heat losses of the building to the outside, both related to the dispersion that to the ventilation;

Q_{ai} = input free heat due to solar energy available inside the room through the glass surfaces;

Q_{ae} = input free heat due to solar energy through the outer surfaces opaque (walls, doors, etc.);

Q_a = input free heat from internal for the presence of people, lighting, etc.;

η_u = utilization factor of the free contributions, taking into account the possible situations in which the contributions exceed the losses, leading to an overheating of the premises. It is therefore penalize the free contributions with a value of this factor <1

Air conditioning plants in industrial environments

Evaluation the normalized energy needs

For plants intermittently, which provides for switching off of the actual heat generator for a certain period of time, or attenuation, with reduction of the heat produced with the consequent decrease of the temperature inside the room of at least 4°C, the ideal requirement of energy Q_h during the reporting period is as follows:

$$Q_h = k \cdot [F_d \cdot (Q_L - Q_{ai}) - \eta_u \cdot F_a \cdot (Q_{ae} + Q_a)]$$

where, in addition to the terms above, one has:

k = coefficient relative to the mode of operation: $k=1$ intermittent (power off without mitigation), $k > 1$ with dependent attenuation of heat storage capacity of the building. According to UNI EN ISO 13790: 2008 is noted that:

$$k = f(t_c, n_{og}, n_{od})$$

Air conditioning plants in industrial environments

Evaluation the normalized energy needs

with:
$$k = f(t_c, n_{og}, n_{od})$$

t_c = time constant of the building, which serves to determine the utilization factor of the free contributions η_u , as dependent on dynamic characteristics of the building;

n_{og} = number of hours of shutdown or attenuation nighttime (from 16 to 8) in a day;

n_{od} = number of hours shutdown or attenuation daytime (from 8 to 16).

Alternatively you can use the coefficients in the table

Operation	Plants at hot air	Plants of radiators	Plants at pannels
Continuous with attenuation nighttime	12	8	5
With daily use of 16-18 hours	15	10	8
With daily use of 12-16 hours	20	12	10
With daily use of 8-12 hours	25	15	12
With daily use of 6-8 hours	30	20	15
With daily use of 4-6 hours	35	25	20

Air conditioning plants in industrial environments

Evaluation the normalized energy needs

For plants intermittently, which provides for switching off of the actual heat generator for a certain period of time, or attenuation, with reduction of the heat produced with the consequent decrease of the temperature inside the room of at least 4°C, the ideal requirement of energy Q_h during the reporting period is as follows:

$$Q_h = k \cdot [F_d \cdot (Q_L - Q_{ai}) - \eta_u \cdot F_a \cdot (Q_{ae} + Q_a)]$$

where, in addition to the terms above, one has:

F_d = reduction factor of the dispersions (< 1);

F_a = reduction factor of the free contributions (< 1).

Except in special cases F_a e F_d can be set equal to 0.98.

Air conditioning plants in industrial environments

Evaluation the normalized energy needs

In the event that the requirement of an ideal energy Q_h during the reporting period is determined by reference to the winter season and therefore relative to the stationary method A, the demand for primary energy required to heat Q is expressed throughout the season.

With the semi-stationary method, the requirement for primary energy required to heat Q is the sum of all the monthly contributions of the heating period.

Air conditioning plants in industrial environments

Evaluation the normalized energy needs

The calculation of the energy exchanged by transmission and ventilation provides to determine:

- heat loss of the building to the outside Q_L , which is related to the dispersion ventilation, defined by the relation:

$$Q_L = (Q_t + Q_g + Q_{tv} + Q_{ta}) + Q_v$$

Are outlined below for completeness the formulas for the calculation of the individual elements, but these are the same contributions in kW used in the calculation of Cd, multiplied by the number of seconds of system operation, that is $3600 * 24 * N$ (number of days established by the common reference).

Air conditioning plants in industrial environments

Evaluation the normalized energy needs

The calculation of the energy exchanged by transmission and ventilation provides to determine:

- heat loss of the building to the outside Q_L , which is related to the dispersion ventilation, defined by the relation:

$$Q_L = (Q_t + Q_g + Q_{tv} + Q_{ta}) + Q_v$$

Q_t = thermal energy transmitted directly to the outside walls, doors etc. and which is defined by the relation:

$$Q_t = k_t \cdot (T_i - T_{em}) \cdot \Delta t$$

with: k_t = coefficiente di dispersione termica (W/°C) definita dalla relazione:

$$k_t = \sum_{i=1}^z (K_i \cdot S_i) + \sum_{j=1}^w (\psi_j \cdot L_j)$$

con: K_i = transmittance of the i-th wall (W/m² °C); S_i = area of the i-th wall (m²); ψ_j = coefficient of thermal dispersion of the j-th thermal bridge (W/m °C); L_j = length of the j-th thermal bridge (m);

Air conditioning plants in industrial environments

Evaluation the normalized energy needs

The calculation of the energy exchanged by transmission and ventilation provides to determine:

- heat loss of the building to the outside Q_L , which is related to the dispersion ventilation, defined by the relation:

$$Q_L = (Q_t + Q_g + Q_{tv} + Q_{ta}) + Q_v$$

Q_t = thermal energy transmitted directly to the outside walls, doors etc. and which is defined by the relation:

$$Q_t = k_t \cdot (T_i - T_{em}) \cdot \Delta t$$

with: T_i = internal temperature of the compartment ($^{\circ}\text{C}$); T_{em} = average outdoor temperature during the period considered ($^{\circ}\text{C}$); Δt = time interval in which it evaluates the thermal energy transmitted directly to the outside walls, doors etc.. (s), which is defined by the relation: $\Delta t = 3600 \cdot 24 \cdot N$

with: N = number of heating days of the period considered;

Air conditioning plants in industrial environments

Evaluation the normalized energy needs

The calculation of the energy exchanged by transmission and ventilation provides to determine:

- heat loss of the building to the outside Q_L , which is related to the dispersion ventilation, defined by the relation:

$$Q_L = (Q_t + Q_g + Q_{tv} + Q_{ta}) + Q_v$$

where:

Q_g = thermal energy transmitted by passing through the soil and which is given by the relation:

$$Q_g = k_g \cdot (T_i - T_{ems}) \cdot \Delta t$$

where:

k_g = coefficient of heat loss through the ground (W/°C), detectable by the UNI EN ISO 13370: 2008;

T_i = internal temperature of the compartment (°C);

T_{ems} = seasonal average outdoor temperature (°C);

Air conditioning plants in industrial environments

Evaluation the normalized energy needs

The calculation of the energy exchanged by transmission and ventilation provides to determine:

- heat loss of the building to the outside Q_L , which is related to the dispersion ventilation, defined by the relation:

$$Q_L = (Q_t + Q_g + Q_{tv} + Q_{ta}) + Q_v$$

where:

Q_{tv} = thermal energy transmitted toward the unheated rooms:

$$Q_{tv} = k_{tv} \cdot (T_i - T_{em}) \cdot \Delta t$$

where: k_{tv} = coefficient of thermal dispersion between the interior and the exterior ($W/^\circ C$) both of transmission both of ventilation, which for a situation shown in the figure and applying the electrical analogy implies a value of:

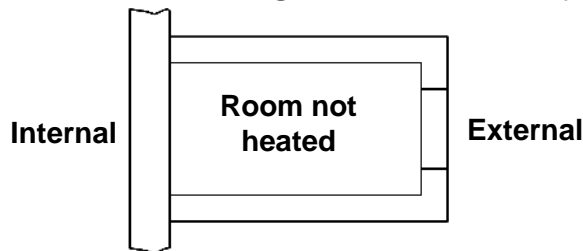

$$k_{tv} = \frac{k_{tv,i} \cdot k_{tv,e}}{k_{tv,i} + k_{tv,e}}$$

Air conditioning plants in industrial environments

Evaluation the normalized energy needs

The calculation of the energy exchanged by transmission and ventilation provides to determine:

- heat loss of the building to the outside Q_L , which is related to the dispersion ventilation, defined by the relation:

$$Q_L = (Q_t + Q_g + Q_{tv} + Q_{ta}) + Q_v$$

where: k_{tv} = coefficient of thermal dispersion between the interior and the exterior ($W/^\circ C$) both of transmission both of ventilation, which for a situation shown in the figure and applying the electrical analogy implies a value of:

$$k_{tv} = \frac{k_{tv,i} \cdot k_{tv,e}}{k_{tv,i} + k_{tv,e}}$$

where: $k_{tv,i}$ = coefficient of thermal dispersion between the internal and room not heated both of transmission both of ventilation ($W/^\circ C$); $k_{tv,e}$ = coefficient of thermal dispersion between room not heated and the outside both of transmission both of ventilation ($W/^\circ C$); T_{em} = average outdoor temperature during the period considered ($^\circ C$);

Air conditioning plants in industrial environments

Evaluation the normalized energy needs

The calculation of the energy exchanged by transmission and ventilation provides to determine:

- heat loss of the building to the outside Q_L , which is related to the dispersion ventilation, defined by the relation:

$$Q_L = (Q_t + Q_g + Q_{tv} + Q_{ta}) + Q_v$$

where:

Q_{ta} = thermal energy transmitted through the compartments to different temperature than the internal project (for example the presence of a refrigerating cell), which is expressed by the relation:

$$Q_{ta} = k_{ta} \cdot (T_i - T_a) \cdot \Delta t$$

where: k_{ta} = coefficient of thermal dispersion through the compartments with different temperature ($W/^\circ C$), detectable in the same way as was done for the thermal energy transmitted to the rooms not heated; T_a = room temperature at a fixed temperature;

Air conditioning plants in industrial environments

Evaluation the normalized energy needs

The calculation of the energy exchanged by transmission and ventilation provides to determine:

- heat loss of the building to the outside Q_L , which is related to the dispersion ventilation, defined by the relation:

$$Q_L = (Q_t + Q_g + Q_{tv} + Q_{ta}) + Q_v$$

where:

Q_v = thermal energy exchanged for ventilation, which is expressed by:

$$Q_v = k_v \cdot (T_i - T_{em}) \cdot \Delta t$$

where: k_{ta} = coefficient of thermal dispersion for ventilation (W/°C), represented as a flow of enthalpy per unit of temperature jump and that can be expressed by:

$$k_v = \rho \cdot c_p \cdot n \cdot V$$

where: ρ = air density = 1,2 kg/m³; c_p = specific heat at constant pressure of the air = 1,006 kJ/kg °C; n = number of renewal of air at hour; V = volume of the building (m³);

Air conditioning plants in industrial environments

Evaluation the normalized energy needs

The calculation of the energy exchanged by transmission and ventilation provides to determine:

- heat loss of the building to the outside Q_L , which is related to the dispersion ventilation, defined by the relation:

$$Q_L = (Q_t + Q_g + Q_{tv} + Q_{ta}) + Q_v$$

where:

Q_{ai} , Q_{ae} = the heat input is free of the individual elements, whether due to transparent surfaces or matte surfaces, can be calculated using the following simplified formula:

$$Q = F * A_{Eff} * I$$

where I is the seasonal average irradiance expressed in kJ/m^2 , F is the reduction factor due to shading (given by the product of the reduction factor to partial shade and external obstructions vertical or horizontal in Figure) and A_{eff} is the effective area of solar collection

Air conditioning plants in industrial environments

Evaluation the normalized energy needs

The calculation of the energy exchanged by transmission and ventilation provides to determine:

- heat loss of the building to the outside Q_L , which is related to the dispersion ventilation, defined by the relation:

$$Q_L = (Q_t + Q_g + Q_{tv} + Q_{ta}) + Q_v$$

where: F is the reduction factor due to shading (given by the product of the reduction factor to partial shade and external obstructions vertical or horizontal in the figure)

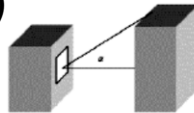

Contesto nel quale è collocato l'edificio	45° N latitudine		
	S	E/O	N
Centro storico	0,46	0,61	0,90
Centro città	0,62	0,70	0,94
Periferia	0,85	0,82	0,98
Campagna	1,00	1,00	1,00

Prospetto XI – Fattore di riduzione dovuto all'ombreggiatura parziale, F_b



Angolo formato dall'oggetto verticale (α)	45° N latitudine		
	S	E/O	N
0°	1,00	1,00	1,00
30°	0,90	0,89	0,91
45°	0,74	0,76	0,80
60°	0,50	0,58	0,66

Prospetto XII – Fattore di riduzione parziale dovuto ad aggetti verticali, F_v (Fonte: UNI 13790).



Angolo formato dall'oggetto orizzontale (β)	45° N latitudine		
	S	E/O	N
0°	1,00	1,00	1,00
30°	0,94	0,92	1,00
45°	0,84	0,84	1,00
60°	0,72	0,75	1,00

Prospetto XIII – Fattore di riduzione parziale dovuto ad aggetti orizzontali, F_f (Fonte: UNI 13790).

Air conditioning plants in industrial environments

Evaluation the normalized energy needs

The calculation of the energy exchanged by transmission and ventilation provides to determine:

- heat loss of the building to the outside Q_L , which is related to the dispersion ventilation, defined by the relation:

$$Q_L = (Q_t + Q_g + Q_{tv} + Q_{ta}) + Q_v$$

where:

Q_{ai} , Q_{ae} = the heat input is free of the individual elements, whether due to transparent surfaces or matte surfaces, can be calculated using the following simplified formula:

$$Q = F * A_{Eff} * I$$

where the effective area is calculated for opaque surfaces from: $A_{Eff} = A * R * K * \alpha$

where A is the net area, R is the thermal resistance of the surface to be determined according the EN ISO 6949, K is the thermal transmittance of the outer surface and α is the absorption factor (0.3 for light-colored surface, 0, 9 dark color gradations and intermediate values for medium).

Air conditioning plants in industrial environments

Evaluation the normalized energy needs

The calculation of the energy exchanged by transmission and ventilation provides to determine:

- heat loss of the building to the outside Q_L , which is related to the dispersion ventilation, defined by the relation:

$$Q_L = (Q_t + Q_g + Q_{tv} + Q_{ta}) + Q_v$$

The effective area is calculated for transparent surfaces and is:

$$A_{Eff} = A * g * F$$

where A is the net area, F is the reduction factor for curtains (table) and g is the total solar energy absorbed by the glass (table). In northern climates $Q_{ae} < 10\%$ of Q_{ai} , although the latter is important as most isolated are the walls of the building

TIPI DI TENDA	PROPRIETA' OTTICHE		FATTORI RIDUZIONE TENDE	
	ASSORBIMENTO	TRASMISSIONE	INTERNE	ESTERNE
Veneziane bianche	0,1	0,05	0,25	0,10
		0,1	0,30	0,15
		0,3	0,45	0,35
Tende bianche	0,1	0,5	0,65	0,55
		0,7	0,80	0,75
		0,9	0,95	0,95
Tessuti colorati	0,3	0,1	0,42	0,17
		0,3	0,52	0,37
		0,5	0,77	0,57
Tessuti rivestiti in alluminio	0,2	0,05	0,20	0,08

TIPI DI VETRO	g
Singolo	0,85
Doppio vetro normale	0,75
Doppio vetro con rivestimento basso-emissivo	0,67
Doppio vetro normale	0,70
Doppio vetro con doppio rivestimento basso-emissivo	0,50
Doppia finestra	0,75

Air conditioning plants in industrial environments

Evaluation the normalized energy needs

The calculation of the energy exchanged by transmission and ventilation provides to determine:

- heat loss of the building to the outside Q_L , which is related to the dispersion ventilation, defined by the relation:

$$Q_L = (Q_t + Q_g + Q_{tv} + Q_{ta}) + Q_v$$

where:

Q_a = free heat input from the presence of people, lighting, etc., which produce heat inside the building.

May be close to the rated power of each unit for the time of use and that can be expressed by the relation:

$$Q_a = \sum_{i=1}^n \sum_{j=1}^m Q_{aij}$$

with:

n = types of equipment considered;

m = number of equipment for each i -th type;

Q_{aij} = nameplate power of the equipment.

Air conditioning plants in industrial environments

Evaluation the normalized energy needs

The calculation of the energy exchanged by transmission and ventilation provides to determine:

- heat loss of the building to the outside Q_L , which is related to the dispersion ventilation, defined by the relation:

$$Q_L = (Q_t + Q_g + Q_{tv} + Q_{ta}) + Q_v$$

If the calculation is too complex because of the lack of data on nameplate power of the equipment you can use the following table which shows the free internal contributions in W/m^2 for different types of buildings:

DESTINAZIONE D'USO	APPORTI MEDI GLOBALI W/m^2
Abitazione con superficie utile di pavimento A minore o uguale a 170.	$5,294*A - 0,01557*A^2$
Abitazione con superficie utile di pavimento A maggiore o uguale a 170.	450 (W)
Edifici adibiti ad albergo o pensioni	6
Edifici adibiti ad uffici e assimilabili	6
Edifici adibiti ospedali cliniche case di cura	8
Cinema teatri sale riunione per congressi	8
Mostre biblioteche musei	8
Bar ristoranti sale da ballo	10
Piscine saune e assimilabili	8
Edifici adibiti ad attività commerciali	10
Palestre e assimilabili	5
Servizio supporto alle attività sportive	4
Edifici adibiti ad attività scolastiche	4
Edifici adibiti ad attività industriali e artigianali	6

Air conditioning plants in industrial environments

Evaluation the normalized energy needs

The ideal energy requirements can be estimated from the relationship:

$$Q_h = k \cdot [F_d \cdot (Q_L - Q_{ai}) - \eta_u \cdot F_a \cdot (Q_{ae} + Q_a)]$$

where:

η_u = utilization factor of the free contributions, taking into account the possible situations in which the contributions exceed the losses, leading to an overheating of the premises. It is therefore penalize the free contributions with a value of this factor < 1

This factor can be calculated with the following relationship: $\eta_u = \frac{1 - \gamma^r}{1 - \gamma^{r+1}}$

with:

γ = defined by the ratio between the gains and the heat losses through the relation:

$$\gamma = \frac{Q_{ai} + Q_a}{Q_a + Q_{ae}}$$

Air conditioning plants in industrial environments

Evaluation the normalized energy needs

The ideal energy requirements can be estimated from the relationship:

$$Q_h = k \cdot [F_d \cdot (Q_L - Q_{ai}) - \eta_u \cdot F_a \cdot (Q_{ae} + Q_a)]$$

where:

τ which is defined by the relation: $\tau = 1 + \frac{t_c}{16}$

where:

t_c = time constant of the building for a day, which can be expressed by the relation:

$$t_c = \frac{C}{K_b \cdot 3600}$$

with:

C = thermal capacity of the building, expressed by the relation: $C = \sum_{j=1}^r (S_j \cdot m_j \cdot c_j)$

where:

S_j = wall surface j-th (m²);

m_j = effective mass or part of the mass of the wall which accumulates energy during the day and is calculated as the product of the density for the depth of penetration of the thermal wave (kg/m²);

c_j = specific heat of the wall (J/kg °C);

Air conditioning plants in industrial environments

Evaluation the normalized energy needs

The ideal energy requirements can be estimated from the relationship:

where:

$$Q_h = k \cdot [F_d \cdot (Q_L - Q_{ai}) - \eta_u \cdot F_a \cdot (Q_{ae} + Q_a)]$$

where:

$$K_k = \frac{Q_L}{(T_i - T_{em}) \cdot \Delta t}$$

K_k = global dispersion coefficient of the building, obtained from the relation:

with:

Q_L = thermal energy exchanged for transmission and ventilation of the building (J);

T_i = internal temperature of the building (°C);

T_{em} = average outdoor temperature during the period (°C);

Δt = time period considered (s);

Air conditioning plants in industrial environments

Evaluation the normalized energy needs

Once you have calculated the FEN, it must be compared with the value set by the Presidential Decree 412/93 supplemented by Presidential Decree 551/1999 (FEN_{limite}) in such $FEN < FEN_{limite}$

$$FEN_{limite} = \left[(C_{d,limite} + 0,34 \cdot N) - \eta_u \cdot \left(\frac{0,01 \cdot I_m + a}{t_i - t_{em}} \right) \right] \cdot \frac{86,4}{\eta_{g,minimo}} \quad (\text{kJ/m}^3 \text{ GG})$$

$C_{d,limite}$ = volume coefficient of dispersion limit ($\text{W/m}^3 \text{ }^\circ\text{C}$);

N = number of days of heating;

η_u = utilization factor of the free contributions;

I_m = average daily irradiance seasonal on the horizontal plane of the months entirely included in the warm-up period (W/m^2);

a = internal contributions of free energy per unit volume (J/m^3);

T_i = internal temperature of the project of the building ($^\circ\text{C}$);

T_{em} = average outdoor temperature during the period considered ($^\circ\text{C}$);

$\eta_{g,minimo}$ = minimum overall average seasonal efficiency.

Air conditioning plants in industrial environments

Evaluation the normalized energy needs

To complete you have to calculate the overall performance of the seasonal mean, in order to ensure that the heating system works with good performance not only at the design load, but even at partial loads during the entire winter season.

The overall efficiency of the seasonal mean is expressed by the relation:

$$\eta_g = \frac{Q_h}{Q}$$

where:

Q_h = heating requirements of the building required to be heated;

Q = demand for primary energy needed for heating.

This is to verify that:

$$\eta_g > \eta_{g, \min imo}$$

being:

$$\eta_{g, \min imo} = 65 + 3 \cdot \log(P_n) \quad (\%)$$

with:

P_n = power of the thermal plant (kW).

Air conditioning plants in industrial environments

Evaluation the normalized energy needs

It is observed that the increase of the thermal power also increases the minimum overall efficiency .

In the case of replacement of the heat generator, you can omit the verification of C_d and FEN, if the rated power of the new generator is equal to or less than the old one. It should however check the combustion efficiency in operation. If the new installed capacity is higher, you have to perform the same tests of a new project, excluding only the C_d .