

Prof. Ing. Dario Pozzetto

Department of Engineering and Architecture – University of Trieste

Via Valerio, 10 – 34127 Trieste – Tel: 040.558.3805 / 7982 Fax: 040.558.3812

E-mail: pozzetto@units.it

INDUSTRIAL PLANTS II

**Chapter five (part 1):
Thermal plants**

**DOUBLE DEGREE MASTER IN
“PRODUCTION ENGINEERING AND MANAGEMENT”**

**CAMPUS OF PORDENONE
UNIVERSITY OF TRIESTE**

Thermal plants

Introduction and definitions

For **heating system** means the integrated components through which regulate the internal temperature of industrial environments.

For **heating system** includes both the elements dedicated to produce and provide heat during the winter (heating system in the strict sense), and the component dedicated to subtract produce heat or cooling during the summer (air conditioning).

The heating system consists of a set of components:

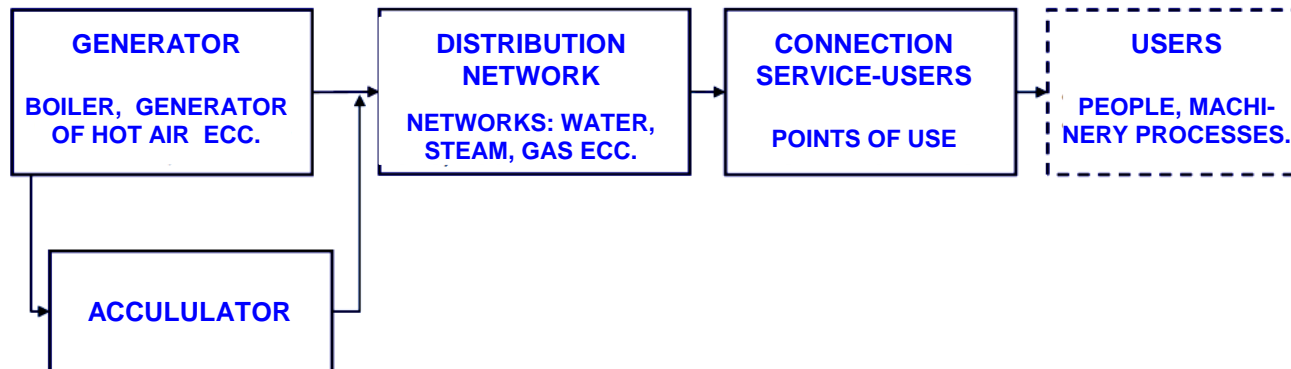

Thermal plants

Introduction and definitions

The heating system consists of a set of components:

a) the generator

The heat generation using boilers firing gas, oil or biomass, electric heaters or heat pumps. For the generation of refrigeration or heat dissipation, however, may be used in refrigeration units, heat pumps or geothermal wells



Thermal plants

Introduction and definitions

The heating system consists of a set of components:

b) the ducts

They enable the carriage of the fluid, when the generator is designed to serve multiple environments through a distribution circuit. The ducts may be tubes, for conveying liquids, vapors and gases at high pressures and temperatures or ducts of different shape, which transport gas at pressures from 2 to 50 kPa and temperatures contained



Thermal plants

Introduction and definitions

The heating system consists of a set of components:

b) the ducts

The constructive characteristics of the ducts depend on the type of fluid (transfer) between the distance between the generator and the user, from their plano-altimetric and from the pressures and temperatures involved.

The design of the distribution network (or piping) in the case of Thermal plants is strongly conditioned by the characteristics of the heat transfer fluid (or transfer), or the fluid which, through changes of its enthalpy, obtained by changes in temperature and/or status, allows you to transfer thermal energy from the producer to the consumer.

Thermal plants

Introduction and definitions

The heating system consists of a set of components:

b) the ducts

The transfer most used in the industrial field are:

- hot water or superheated;
- saturated steam or superheated;
- heat transfer of fluids;
- transfer gaseous (air, CO₂, helium etc.).

Thermal plants

Introduction and definitions

The heating system consists of a set of components:

b) the ducts

The parameters of choice of the transfer are the following:

- chemical-physical characteristics: easy to handle, non-toxic, readily available, chemically stable, transportable at high speed and with good thermal capacity and good ability to convective exchange;
- economic characteristics: low cost of installation and operation.

The fluid used in most applications is the steam as it allows a thermal exchange greater than the water and the air. Alternatively you can use the heat transfer fluids

Thermal plants

Introduction and definitions

The heating system consists of a set of components:

c) the user

He is the customer who benefits from the sale of the calories/refrigeration produced in environments served or technological processes. The transfer can operate in:

- at open circuit, where delivery is direct to the environment or to the process through the use of radiant systems (radiators, radiant panels, radiant plates) and convection (convectors, fan coils);
- at closed circuit, in which the terminal equipment is a heat exchanger, which allows you to give in to the process heat energy conveyed by the transfer and prevent the same from scattering in the process, allowing you to retrieve it for the next cycle

Thermal plants

Introduction and definitions

The heating system consists of a set of components:

d) the heat exchanger

The heat exchanger is a component in which there is an exchange of thermal energy between two fluids at different temperatures.

Thermal plants

Introduction and definitions

The heating system consists of a set of components:

d) the heat exchanger

The heat exchangers can be divided into:

- exchangers mixture (or contact)

In this heat exchanger the two streams exchange heat and matter since they are not separated by walls (for example evaporative tower of cooling or degasser in the cycles of steam. The mixture exchangers operate a simple mixing of the fluids, bringing them to the same temperature

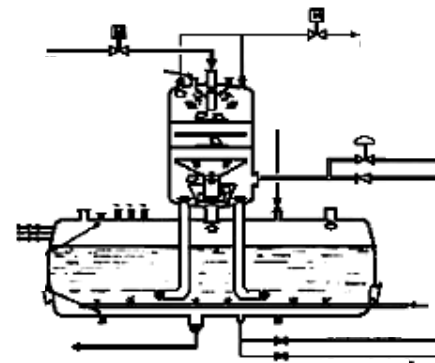
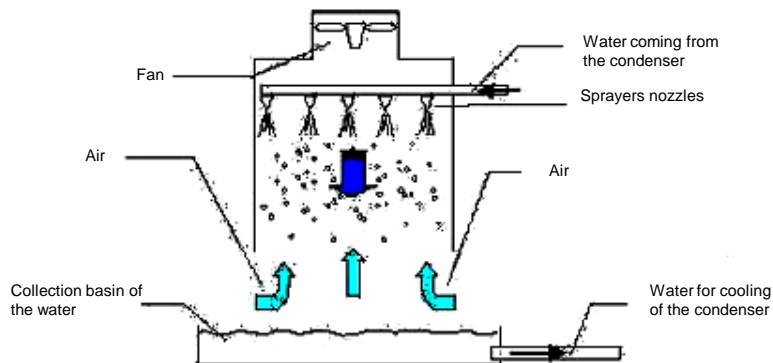

Thermal plants

Introduction and definitions

The heating system consists of a set of components:

d) the heat exchanger

The heat exchangers can be divided into:

- exchangers of the regenerative type

This heat exchanger currents are sent alternately into a chamber of inert brick (recuperators Cowper), or in special units at rotating plate (exchanger Ljungstrom); a drawback of these heat exchangers is formed by partial mixing between the two fluids

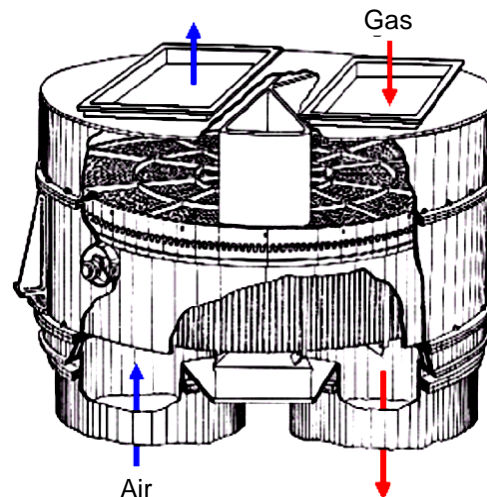

Thermal plants

Introduction and definitions

The heating system consists of a set of components:

d) the heat exchanger

The heat exchangers can be divided into:

- exchangers to direct radiation

In such a heat exchanger is provided in the form of radiant energy from the solar panels

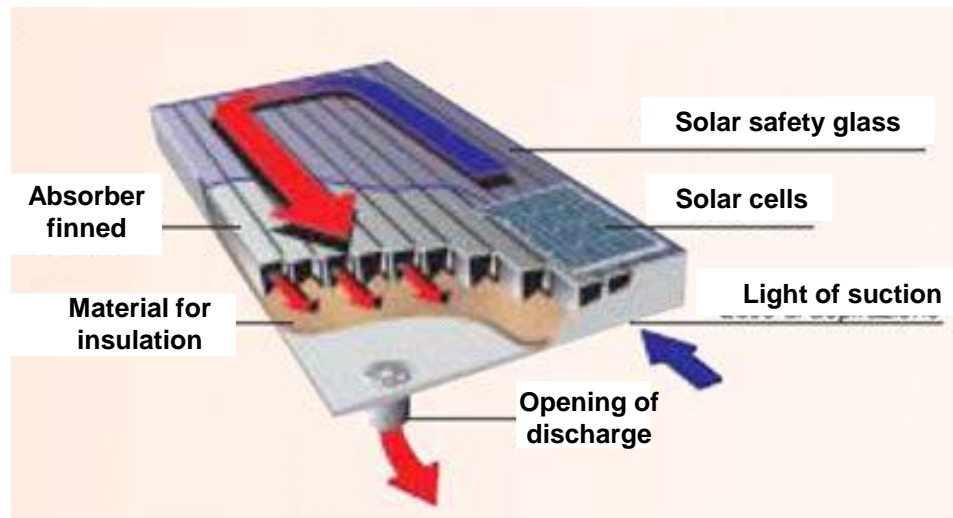

Thermal plants

Introduction and definitions

The heating system consists of a set of components:

d) the heat exchanger

The heat exchangers can be divided into:

- exchangers at surface

They are exchangers most commonly used and in which the currents absorb heat from the surfaces with which they are separated. The principle of operation related to these exchangers provides that a fluid to pass in the mantle, while the other steps in the tubes.

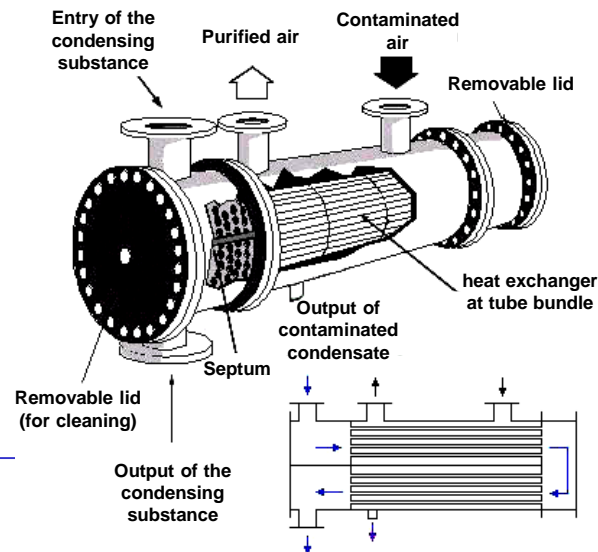

Thermal plants

Introduction and definitions

The heating system consists of a set of components:

d) the heat exchanger

The heat exchangers can be divided into:

- exchangers at surface

In the mantle of the diaphragms are positioned of baffles, which have the purpose of increasing the convective coefficient on the outer side, following the increase of the turbulence and the presence of a velocity component normal to the axis of the tubes.

The advantages of this type of heat exchanger are basically two:

- obtain a large exchange area with limited dimensions;
- have an ease of maintenance.

Thermal plants

Introduction and definitions

The heating system consists of a set of components:

d) the heat exchanger

The heat exchangers can be divided into:

- exchangers at surface

By contrast, the main disadvantage is the weight. The figure shows a scheme:

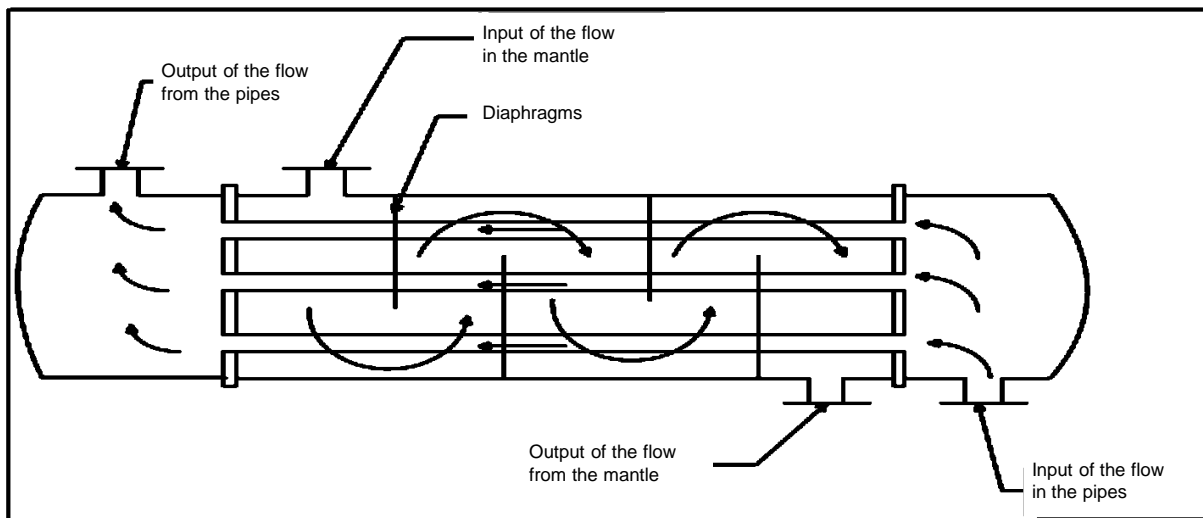

Thermal plants

Introduction and definitions

The heating system consists of a set of components:

d) the heat exchanger

The heat exchangers can be divided into:

- exchangers at surface

In it we recognize two sides, containing the fluids. By virtue of the first principle of thermodynamics, the bodies must be at different temperatures because there is transfer of thermal energy from one to another, and thus define a hot side and a cold side. These sides have different characteristics depending on the type of heat exchanger.

At the base of the first law of thermodynamics is the equivalence of heat and work, and energy conservation. The energy of a thermodynamic system is neither created nor destroyed, but is transformed, passing from one form to another.

Thermal plants

Introduction and definitions

Depending on the configuration of the motion one can distinguish:

- heat exchangers in equicurrent (in parallel currents equally orientated)

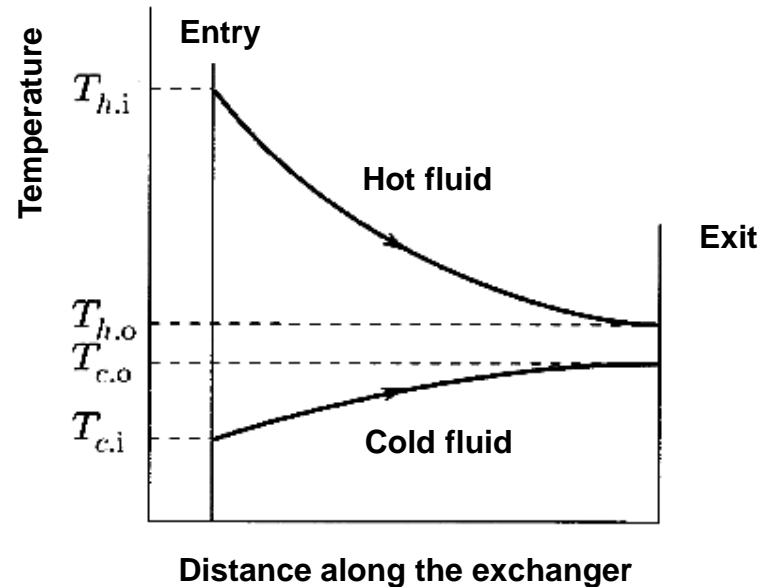
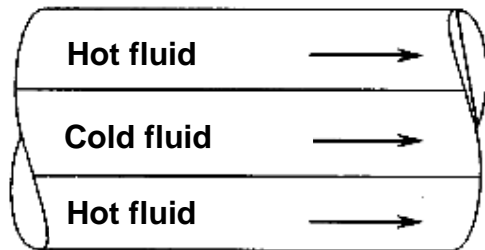

Thermal plants

Introduction and definitions

Depending on the configuration of the motion one can distinguish:

- heat exchangers in countercurrent (in parallel currents in opposite directions)

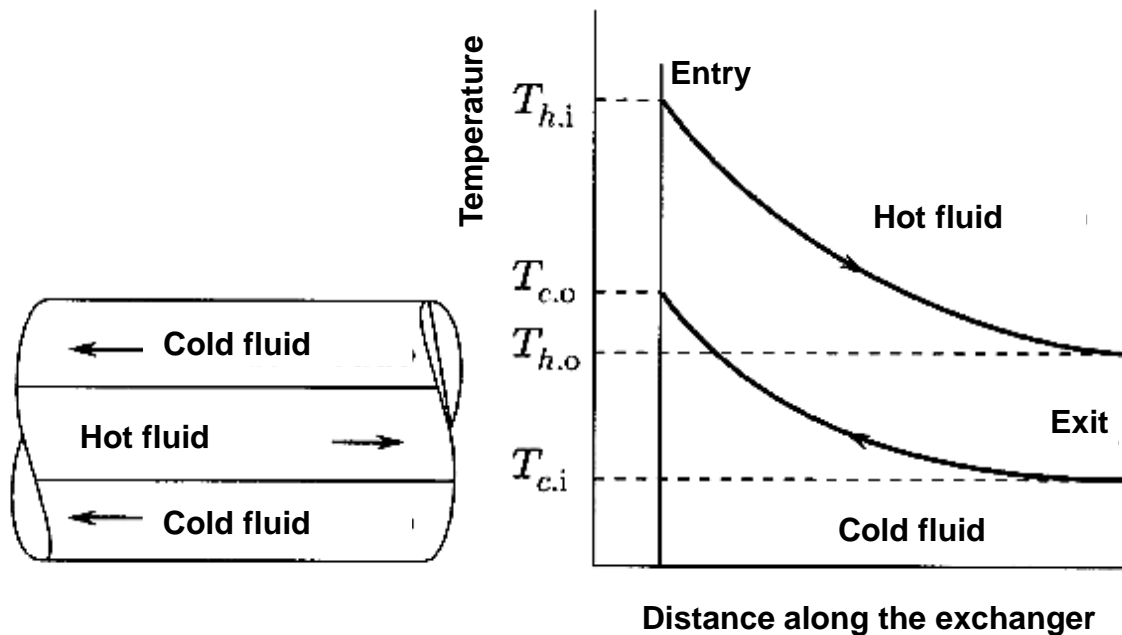

Thermal plants

Introduction and definitions

Depending on the configuration of the motion one can distinguish:

- cross-flow heat exchangers

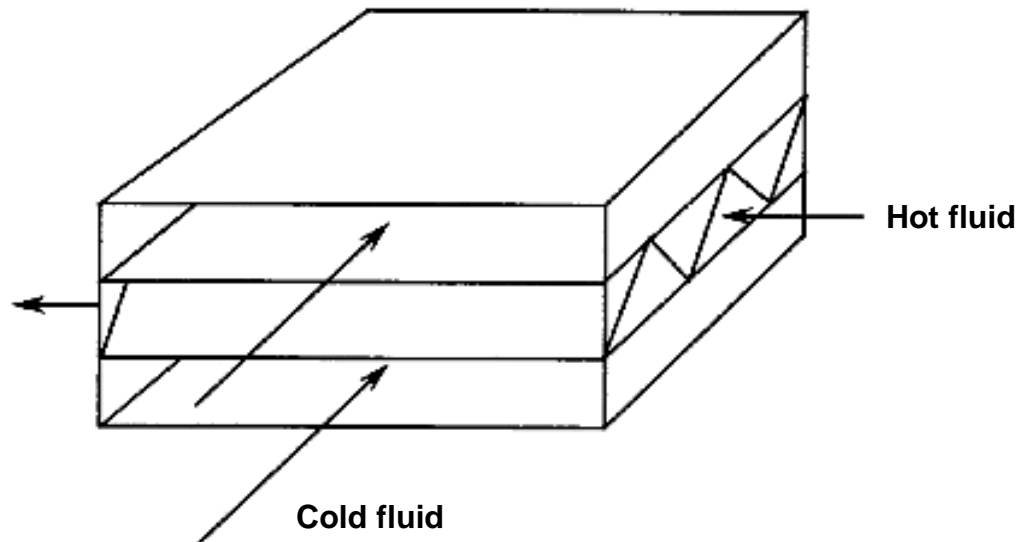

Thermal plants

Introduction and definitions

The constructive configurations are characterized then according to the geometric complexity, from simple exchanger "tube in tube" up to the types at plate or finned tubes.



Thermal plants

Introduction and definitions

A parameter for evaluating the geometry is the ratio of the exchange surface and the volume. The heat exchangers with high values of this ratio ($> 700 \text{ m}^2/\text{m}^3$) are said compact, and are rendered necessary when the overall coefficient of heat exchange is particularly low (such as a gas-gas exchanger); if you do not adopt compact heat exchangers in these situations you would surfaces and dimensions therefore very high and prohibitive.

Thermal plants

Introduction and definitions

In a heat exchanger at surface the two fluids are separated by a wall surface S , whereby the heat exchange between the hot fluid (temperature T_c) and the cold (temperature T_f), takes place through convection in the first fluid, then by conduction through the wall thickness s and thermal conductivity λ and again to convection in the second fluid. The heat exchange by radiation can be neglected in the heat exchangers, unless it is in the presence of gas at high temperature coming from a combustion, such as occurs in a heat generator.

Thermal plants

Introduction and definitions

The amount of heat exchanged will be then given by the relation:

$$Q = K \cdot S \cdot (T_c - T_f) \cdot \Delta t$$

where:

K = overall heat transfer coefficient (W/m² °C), defined by the relation:

$$K = \frac{1}{\frac{1}{\alpha_c} + \frac{s}{\lambda} + \frac{1}{\alpha_f}}$$

with:

α_c = coefficient of convective of fluid exchange of heat transfer hot (W/m² °C);

s = thickness of the wall of the heat exchange (m);

λ = thermal conductivity of the exchange wall (W/m °C);

α_f = coefficient of convective exchange of cold fluid (W/m² °C);

S = exchange surface of the heat exchanger (m²);

Thermal plants

Introduction and definitions

The amount of heat exchanged will be then given by the relation:

$$Q = K \cdot S \cdot (T_c - T_f) \cdot \Delta t$$

where:

$\Delta\theta_{ml}$ = thermal variation with logarithmic mean, defined by the relation:

$$\Delta\theta_{ml} = \frac{(\Delta\theta_c - \Delta\theta_f)}{\ln\left(\frac{\Delta\theta_c}{\Delta\theta_f}\right)}$$

$\Delta\theta_c$ = in a countercurrent heat exchanger, where the specific heat of the hot fluid C_c is greater than that of the cold fluid C_f (figure), is the temperature difference between the inlet temperature of the heat transfer fluid hot T_e and output of the fluid used by the user = $T_e - T_{u-f}$; otherwise, always in a countercurrent heat exchanger where $C_f > C_c$, $\Delta\theta_c = T_u - T_{e-f}$; finally, in the exchangers equicurrent, $\Delta\theta_c = T_e - T_{e-f}$ whatever are the specific heats.

Thermal plants

Introduction and definitions

You define efficiency of a heat exchanger the ratio between the thermal power actually exchanged and the maximum thermal power exchangeable. This allows you to say that you will try fluid heat carriers with high convective heat transfer coefficients (α_c, α_f) and heat exchangers with large exchange surface, high coefficient of heat conductive and limited wall thickness of exchange.

Thermal plants

Introduction and definitions

You define efficiency of the heat exchanger the ratio between the power exchanged by the two fluids and the one that would exchange if the exchange surface is infinite:

$$\varepsilon = \frac{Q_0}{Q_\infty}$$

where Q_∞ is precisely the exchangeable maximum thermal power with the exchange surface infinite and therefore with C_c or C_f equal to zero. Note the figure in which the Q_∞ is obtained with $\Delta\theta_f = 0$.

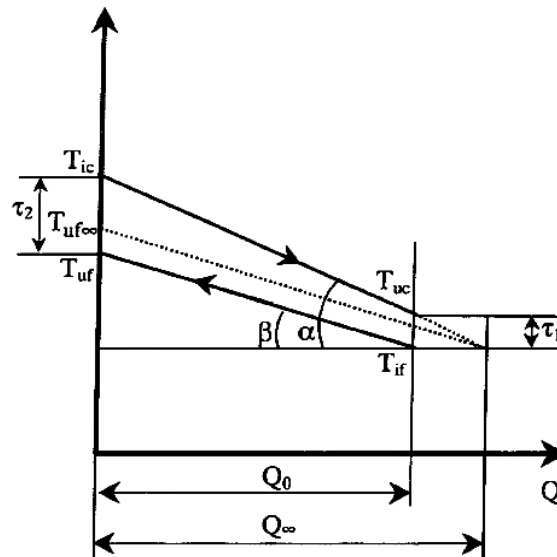

Thermal plants

Introduction and definitions

The efficiency of a heat exchanger is function of the characteristics of the two fluids and of the respective mass flow rates, and of the overall thermal conductance, determined by the geometrical characteristics of the exchanger, and of the motion of fluids.

Thermal plants

Legislation on thermal plants

Law 10/91 lays down the rules for the containment of energy consumption in public buildings and private, whatever its intended use and apply to new buildings and facilities and the renovation of existing buildings and installations.

Thermal plants

Legislation on thermal plants

The recent decrees of implementation, provided by the law, are:

- **Presidential Decree 412/93**, which dictates the requirements, limits of performance and sizing of thermal plants, the minimum return of heat generators, the requirements for the thermoregulation and heat metering (including the obligation, using certain conditions, the installation of the valves thermostatic and of susceptibility to heat metering), the operating limits of the thermal plants and the prescriptions on exercise and maintenance of thermal plants and the related controls

Thermal plants

Legislation on thermal plants

The recent decrees of implementation, provided by the law, are:

- **D.M. 13.12.1993**, that approving the reports and the models to be used for the compilation of the technical report to be filed at the municipal offices of the works relating to thermal plants newly installed in existing buildings and the works relating to the restructuring of thermal plants, and the replacement of the generators heat

Thermal plants

Legislation on thermal plants

The recent decrees of implementation, provided by the law, are:

- **Ministerial Decree of 12 April 1996**, that emanates the provisions relating to the design, construction and operation of thermal plants (air conditioning of buildings and environments, centralized production of hot water, hot water and/or steam etc.) of the total heat input greater 35 kW powered by gaseous fuels to the maximum pressure of 0.5 bar and identifies the security measures to achieve the security objectives for the preservation of the people, the buildings and the rescuers (avoid dangerous accumulations of gas fuel in places of installation and the premises directly communicating with them, limit, in case of accidental event, personal injury and damage to the premises close to those containing plants)

Thermal plants

Legislation on thermal plants

The recent decrees of implementation, provided by the law, are:

- **Presidential Decree of 21 December 1999, n. 551**, which contains the amendments to Presidential Decree 412/93 on the design, installation, operation and maintenance of thermal plants in buildings, in order to control energy consumption

Thermal plants

Legislation on thermal plants

The recent decrees of implementation, provided by the law, are:

- **Ministerial Decree n. 37 of 28 January 2008**, laying down for the installation, the transformation and expansion of heating, air conditioning and refrigeration of any nature or kind, including the works of evacuation of combustion products and condensates, and ventilation and aeration in the room you drawn up a project from a professional entitled to practice according to the specific technical skills required while, in other cases, you prepared, alternatively, by the technical manager of the install

Thermal plants

Legislation on thermal plants

Regarding the criteria for the calculation and design, the Presidential Decree 412/93 refers to a range of UNI and in particular:

- **UNI EN 12831: 2006**, which provides methods for the calculation of heat loss of the project and the thermal load in the design conditions. It can be used for all the buildings with an internal height not greater than 5 m, assumed under stationary thermal conditions of the project

Thermal plants

Legislation on thermal plants

Regarding the criteria for the calculation and design, the Presidential Decree 412/93 refers to a range of UNI and in particular:

- **UNI EN ISO 13790: 2008**, which provides calculation methods for the evaluation of the energy required for heating and cooling of the rooms of residential and non-residential buildings, or of a part of the same

Thermal plants

Legislation on thermal plants

Regarding the criteria for the calculation and design, the Presidential Decree 412/93 refers to a range of UNI and in particular:

- **UNI EN ISO 10077-1: 2007**, which specifies the methods of calculation of the thermal transmittance of windows and pedestrian doors consisting of glazed or opaque panels inserted into frames with or without shutters

Thermal plants

Legislation on thermal plants

Regarding the criteria for the calculation and design, the Presidential Decree 412/93 refers to a range of UNI and in particular:

- **UNI EN ISO 10077-2: 2012**, which specifies a method and provides the input data of reference for the calculation of the thermal transmittance of the profiles of the frames and the linear thermal transmittance of their conjunction with stained glass or opaque panels

Thermal plants

Legislation on thermal plants

Regarding the criteria for the calculation and design, the Presidential Decree 412/93 refers to a range of UNI and in particular:

- **UNI/TS 11300-1: 2014**, which defines the procedures for the national implementation of UNI EN ISO 13790: 2008: with reference to the method for calculating the monthly needs of thermal energy for heating and cooling

Thermal plants

Legislation on thermal plants

Regarding the criteria for the calculation and design, the Presidential Decree 412/93 refers to a range of UNI and in particular:

- **UNI/TS 11300-2: 2014**, which providing the data and the methods for determining of the need for useful energy for hot water, and the yield of electric energy needs of auxiliary systems of heating and hot water, and primary energy requirements for space heating and for the production of domestic hot water. It applies to new systems design, renovated or existing: for heating only, mixed or combined for heating and domestic hot water and one for hot water production for sanitary use

Thermal plants

Legislation on thermal plants

Regarding the criteria for the calculation and design, the Presidential Decree 412/93 refers to a range of UNI and in particular:

- **UNI EN 15316-1: 2008**, which defines the schema for the calculation of the energy used by the plant for the heating and the production of domestic hot water in buildings

Thermal plants

Legislation on thermal plants

Regarding the criteria for the calculation and design, the Presidential Decree 412/93 refers to a range of UNI and in particular:

- **UNI EN 15316-2-3: 2008**, which has the aim to provide a methodology to calculate/estimate the thermal losses in the distribution networks of heating water and the relative electrical energy needs auxiliary

Thermal plants

Legislation on thermal plants

Regarding the criteria for the calculation and design, the Presidential Decree 412/93 refers to a range of UNI and in particular:

- **UNI 10349: 1994**, which provides the data necessary for the climate conventional design and verification of both the buildings both of the technical installations for heating and cooling

Thermal plants

Legislation on thermal plants

Regarding the criteria for the calculation and design, the Presidential Decree 412/93 refers to a range of UNI and in particular:

- **UNI 10351: 2015**, which integrates with the data of permeability to water, the data of the thermal conductivity of the materials used in the building industry

Thermal plants

Legislation on thermal plants

Regarding the criteria for the calculation and design, the Presidential Decree 412/93 refers to a range of UNI and in particular:

- **UNI 10355: 1994**, which provides the values of the thermal resistance unit relating to the types of walls and floors most widespread in Italy

Thermal plants

Legislation on thermal plants

All the thermal plants are subject to review and verification by INAIL (National institute for insurance against accidents at work) and ARPA (Regional Agency for Environmental Protection), who have the task of preventing injuries and to verify the efficiency of the plants.

The Thermal plants can be classified according to the type of use defined by the destination: space heating, hot water services, heating and services, meeting areas public, industrial and other environments.

The Law of 30 July 2010, n. 122 conversion with amendments of Decree 78/2010, provides for the allocation at the INAIL of the functions previously carried out by ISPES (Institute higher for the prevention and safety at work).

Thermal plants

Legislation on thermal plants

The classes of potentials of heat generators are five and depending on the class of each heat generator must meet specific legislative standards and techniques:

- up to 35 kW;
- from 35 to 116 kW;
- from 116 to 350 kW;
- from 350 to 1162 kW;
- more than 1162 kW.

1 kW = 860 kcal/h and 35 kW = 30.000 kcal/h

Thermal plants

Legislation on thermal plants

The premises when are found the thermal power plants with capacities between 35 and 116 kW are subject to the legislative provisions pertaining to the Ministry of the Interior, and numbers greater than 116 kW shall be subject, in addition to legislative provisions pertaining to the Ministry of the Interior, also the issue of the “certificate of fire prevention” by the Command of the Fire Brigade.

Thermal plants

Legislation on thermal plants

For the thermal power industry the body in charge shall make the following checks:

- design examination of the heat generator;
- approval of the layout of thermal power plant;
- examination of the chemical characteristics of the feed water of the heat generator (e.g. hardness, expressed in French degrees);
- site inspections completed installation work and during the first tests;
- periodic checks during operation of the heating system.

The French degree (°f) is a measure of the hardness of the water. The hardness of water expresses the content of salts of calcium, magnesium and ions dissolved in it like carbonates, bicarbonates, sulfates, nitrates and chlorides. The French degrees express such a salt content by referring to the equivalent of CaCO_3 present in a unit volume of water. The value of the hardness of water in French degrees is obtained by multiplying by 10 the amount of CaCO_3 present in it, expressed in mmol/l (millimoles per liter). Or by dividing by 10 the content of CaCO_3 expressed in mg/l.

Thermal plants

Legislation on thermal plants

They are also prescribed, according to the Decree 18 February 2005, n. 59 and Decree 3 April 2006, n. 152, the standards in environmental protection, with particular reference to the reduction of emissions from thermal plants, whose permission must be sought to the competent authority shall verify that emissions do not exceed the specified values.

For thermal power potential of more than 35 kW, the DM 12 April 1996 defines the:

- characteristics of the room is included in these buildings for another purpose or inserted in the volume of the building itself;
- characteristics of the gas supply;
- the characteristics of the combustion apparatus.

Thermal plants

Legislation on thermal plants

The C. M. 29 July 1971, n. 73 contains provisions for fire prevention in thermal plants with a capacity of 35 kW powered by fuel oil or diesel oil, and in particular:

- the location and construction of the local thermal power plant;
- the location and physical characteristics of the tanks the fuel;
- the pipes and devices for feeding the burner of the heat generator.

In the case of thermal plants powered by gas fuel, the fire prevention uses the DM 12 April 1996 subsequently updated by DM 23 July 2001.

Thermal plants

Heat sources for thermal plants

The choice of the thermal generator depends on the source of heat available and on the type of fluid used to transfer heat from the generator to the load.

The heat sources available in the industrial field are:

- gaseous, liquid and solid fossil fuels;
- recovered fuels (e.g. processing waste wood);
- heat recovery by industrial processes;
- electric energy;
- refrigerating plants;
- heat pumps designed to provide or subtract heat.

The heat pump is a machine capable of transferring thermal energy from a body at a lower temperature to a body at a higher temperature or vice versa, using different forms of energy, usually electrical. We have 4 stages: evaporation of the freon that absorbs heat subtracting at the air or other means, compression of freon (gas) that absorbs more heat for conversion of mechanical work-thermal, condensation of freon that transfers the heat absorbed in the two previous stages, at the water or air, and expansion of the freon that reduces its pressure and temperature (liquid).

Thermal plants

Heat sources for thermal plants

The fuels of technical interest and common use are fossil fuels derived from petroleum consisting of mixtures of hydrocarbons (compounds of hydrogen and carbon) and trace elements/inorganic compounds (sulfur, nitrogen, oxygen, metals etc.).

Total U.S. energy use = 94.6 quadrillion Btu

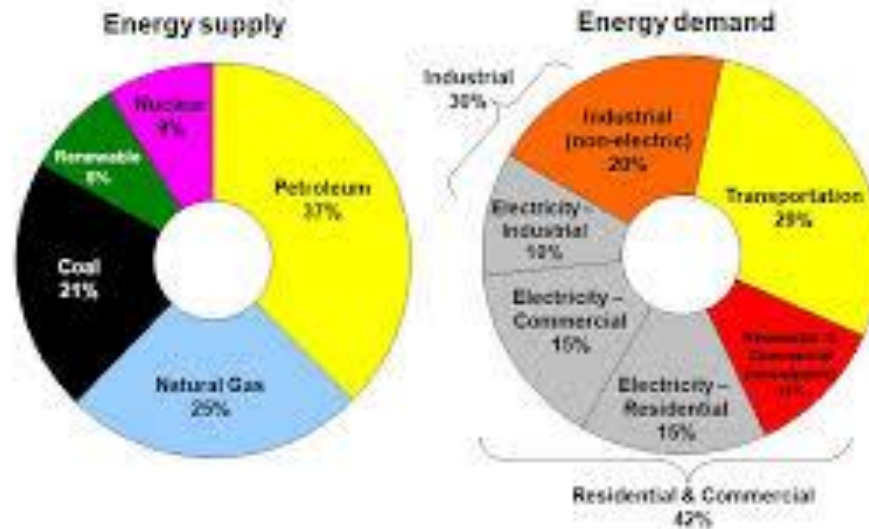

Thermal plants

Heat sources for thermal plants

The fuels can be classified:

a) based on fields of application/use:

- device type and/or use: combustion engine, heat generator etc .;
- calorific value;

b) based on the physical state of aggregation:

- gas;
- liquids;
- solid.

The "calorific value" expresses the maximum amount of heat that can be derived from the complete combustion of 1 kg of fuel (or 1 m³ of gas) at 0°C and 1 bar (J/kg). The calorific value is the amount of heat that becomes available due to the complete combustion at constant pressure of the density of the fuel, when the combustion products are reported to the initial temperature of the fuel and the combustion air. As a part of the heat is dispersed theoretically available for the heating of the fumes and for the vaporization of water produced by combustion. $P_{ci} = P_{cs} - \text{heat of condensation of water vapor.}$

Thermal plants

Heat sources for thermal plants

The combustion process is an exothermic oxide-reduction between the fuel based on carbon, which oxidizes, and the combustion agent represented by the oxygen present in the air, which is reduced, with release of energy (heat) and formation of new compounds, mainly carbon dioxide and water.

For a carbide of hydrogen, expressed by the formula C_mH_n , whose molecular weight is $\mu = 12 \cdot m + n$ we have:

$$\mu \text{ kg } C_mH_n + (32 \cdot m + 8 \cdot n) \text{ kg } O_2 = 44 m \text{ kg } CO_2 + 9 \cdot n \text{ kg } H_2O + (\text{in vapor } 4,184 \cdot \mu \cdot q_i \text{ kJ or in liquid } 4,184 \cdot \mu \cdot q_s \text{ kJ})$$

where:

$$q_i = q_s - 2510,4 \cdot \frac{9 \cdot n}{\mu} \text{ kJ per 1 kg di } C_mH_n$$

and which is determined experimentally or is approximated with:

$$q_s = 34057,8 \cdot \frac{12 \cdot m}{\mu} + 142674,4 \cdot \frac{n}{\mu} \text{ kJ per 1 kg di } C_mH_n$$

Thermal plants

Heat sources for thermal plants

The quantities expressed in m³ or kg at 15°C and 1 bar are:

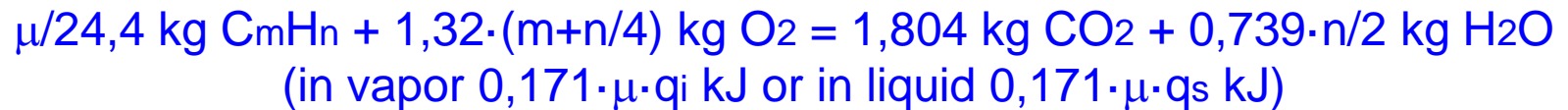
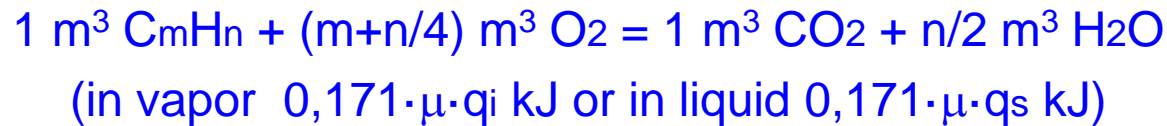

Thermal plants

Heat sources for thermal plants

The heat of reaction product per unit weight ($T = 25^{\circ}\text{C}$) is the calorific value. The fuels of technical interest and the common use of fossil are gaseous and liquid fuels consisting of hydrocarbons (compounds of hydrogen and carbon) and trace elements/inorganic compounds (sulfur, nitrogen, oxygen, metals etc.).

The hydrocarbons can be divided into aliphatic and aromatic.

Thermal plants

Heat sources for thermal plants

The aliphatic hydrocarbons are distinguished in turn into:

- **saturated hydrocarbons, alkanes or paraffins**: are hydrocarbons with single bonds open-chain or cyclic (cycloalkanes);
- **unsaturated hydrocarbons**: are hydrocarbons in which some of the C-C bonds are double bonds (alkenes) and triple bonds (alkynes).

The aromatic hydrocarbons are benzene and substituted derivatives of benzene and polycyclic aromatic hydrocarbons (PAHs).

The gaseous fossil fuels are essentially constituted by paraffin hydrocarbons by 1 (methane) up to 4 carbon atoms (butane).

Natural gas consists of methane (CH_4), traces of ethane (C_2H_6), propane (C_3H_8), nitrogen (N_2) and sulfur (S).

Il gas di petrolio liquefatto (GPL) è costituito da propano (C_3H_8) e butano (C_4H_{10}), e tracce di etano (C_2H_6) e etano (C_2H_4).

Thermal plants

Heat sources for thermal plants

Other fuels which may be used are:

- **gas from coal, peat, wood or biomass** (reducing combustion in the air), which present che presentano 20-30% of CO, 10-20% of H₂, 3-10% of CO₂ and 45-55% of N₂. They have a low calorific value;
- **water gas** (air of coal or coke to have high temperature);
- **Hydrogen** produced by steam reforming of natural gas, by partial oxidation of hydrocarbons or for the gasification of coal.

Steam reforming is a reaction of industrial interest for the production of syngas from hydrocarbons, often methane and water vapor. The reaction is divided into two phases:

- primary reforming: $\text{CH}_4 + \text{H}_2\text{O} \rightarrow \text{CO} + 3 \text{H}_2$
- secondary reforming: the obtained gas mixture contains CH₄ residual, CO, H₂O and H₂. Is made to a post-combustion with air at the end of which is obtained a greater concentration of CO and H₂, and a lower concentration of CH₄ residual.

Thermal plants

Heat sources for thermal plants

The **gaseous fuels** have the following characteristics:

- high combustion efficiency;
- flame stability (low speed of propagation);
- ease of transport;
- low content of inorganic contaminants (low environmental impact).



Thermal plants

Heat sources for thermal plants

The **liquid fossil fuels** are derived from oil distillation and/or refining of petroleum products.

The liquid fuels for industrial use are:

- **gasolines**: C₅-C₉ (aliphatic and aromatic)

The gasolines are not directly obtained from the distillation of petroleum, but are a mixture of hydrocarbons of 4 to 10 carbon atoms obtained from various treatment processes and raffination of the distillate oil. The gasolines are a complex mixture of products of aliphatic and aromatic hydrocarbons in varying proportions, depending on the origin and according to the destination of use, but in which the species aliphatic (paraffin, olefins, naphthenic) are in a field of number of carbon atoms which ranges from 4 to 10 carbon atoms and which are generally more prevalent than the aromatic species (primarily alkylated benzene);

Thermal plants

Heat sources for thermal plants

The **liquid fossil fuels** are derived from oil distillation and/or refining of petroleum products.

The liquid fuels for industrial use are:

- **gasoil**: C₁₂-C₂₀ (aliphatic and aromatic)

The gasoil is a mixture of hydrocarbons including in a temperature range higher boiling since the aliphatics ranging from 12 to 20 carbon atoms with an aromatic content of about 30%. The aromatics content in gasoils contain higher proportions of polycyclic at two (naphthalene) and three rings (phenanthrene). The sulfur content can be significant;

Thermal plants

Heat sources for thermal plants

The **liquid fossil fuels** are derived from oil distillation and/or refining of petroleum products.

The liquid fuels for industrial use are:

- **fuel oil**: C₁₄-C₃₀ (aliphatic and aromatic)

The fuel oils are liquid fuels heavier for which the field of distillation, and the final temperature of the distillation, it is often not measurable or not representative because the heavier components as the temperature increases undergo of the pyrolysis reactions rather than simple evaporation. You can distinguish fuel oil distillates and residual fuel oils of the distillation process. The content of aromatic as well as the sulfur content are in this class of fuels, particularly high and the chemical composition is difficult to assess.

Are distinct fuel oils BTZ (low sulfur) in a proportion below 1% and fuel oils ATZ (high sulfur) with a sulfur percentage of more than 1% and less than 3%, even if the latter are little used in industrial companies.

Thermal plants

Heat sources for thermal plants

The **liquid fuels** have the following characteristics :

- high combustion efficiency;
- ease of storage and transport;
- environmental impact in dependence of the type of fuel.



Thermal plants

Heat sources for thermal plants

The **solid fuels** are little used in industries (coal in thermal power plants), even if they have the following characteristics :

- combustion with low efficiency;
- management problems due to the formation of ash and high environmental impact;
- low cost.



Thermal plants

Heat generators

The purpose of the **heat generator** is to transfer the heat, produced by a reaction, to a fluid, with the maximum yield possible. The generation of heat takes place solely by the combustion process.

The **heat generator** is formed by two essential parts:

- a) **combustion zone**, in which there is the production of heat through the process of combustion of the fuel with the combustion air;
- b) **cession zone of heat to the fluid used** for their carriage to the user.



Thermal plants

Heat generators

The effective yield of a heat generator is provided by the relationship:

- in the case of fluids that operate without state change:

$$\eta = \frac{G_t \cdot (h_u - h_i)}{G_c \cdot H_c} = \frac{G_t \cdot c_m \cdot (t_u - t_i)}{G_c \cdot H_c}$$

- in the case of fluids that operate with state change:

$$\eta = \frac{G_t \cdot [(h_e - h_i) + x \cdot r + (h_u - h_e)]}{G_c \cdot H_c} = \frac{G_t \cdot [c_{ml} \cdot (t_e - t_i) + r \cdot x + c_{mv} \cdot (t_u - t_e)]}{G_c \cdot H_c}$$

where:

G_t = mass flow rate of the carrier fluid (kg/h); G_c = mass flow of the fuel (kg/h); H_i = lower heating value (J/kg); h_u = enthalpy of output of the carrier fluid; h_i = enthalpy of entry of the carrier fluid; h_e = enthalpy of change of state of the fluid carrier; c_m = mass heat capacity in the temperature range $t_u, -t_i$ (J/°C kg); c_{ml} = mass heat capacity of the fluid carrier liquid in the temperature range $t_e, -t_i$ (J/°C kg); c_{mv} = heat capacity mass of superheated steam in the temperature range $t_s, -t_e$ (J/°C kg); r = heat of vaporization (J/kg); x = steam title ($x < 1$ for wet steam and $x = 1$ for dry steam or superheated); t_u = outlet temperature of the carrier fluid without change of state (°C); t_i = inlet temperature of the carrier fluid without change of state (°C); t_e = temperature change of state (°C).

Thermal plants

Heat generators

The actual overall yield of a heat generator taking into account of the utilities is equal to:

- in the case of fluids that operate without state change:

$$\eta = \frac{G_t \cdot c_m \cdot (t_u - t_i)}{G_c \cdot H_c + E_a}$$

- in the case of fluids that operate with state change:

$$\eta = \frac{G_t \cdot [c_{ml} \cdot (t_e - t_i) + r \cdot x + c_{mv} \cdot (t_s - t_e)]}{G_c \cdot H_c + E_a}$$

where:

E_a = energy supplied by the various utilities necessary for the operation of the generator (electricity for fans that convey the combustion air and the flue of the fireplace, electric power for the pumps that move the liquid fuel, steam and compressed air to the spraying of the fuel or the cleaning of the heat exchange surfaces, and the electrical energy and/or the compressed air used for the automatic adjustment system of the heat generator).

Thermal plants

Heat generators

The limit efficiency combustion, inferred from the DPR 660/96, are reported in table

Type of boiler	Intervals of power (kW)	Efficiency at rated output		Efficiency at part load	
		Average water temperature (°C)	Expression efficiency (%)	Average water temperature (°C)	Expression efficiency (%)
Standard boilers	4 – 400	70	$\geq 84 + 2 \cdot \log P_n$	≥ 50	$\geq 80 + 3 \cdot \log P_n$
Low temperature boilers	4 – 400	70	$\geq 87,5 + 1,5 \cdot \log P_n$	40	$\geq 87,5 + 1,5 \cdot \log P_n$
Gas condensing boilers *	4 – 400	70	$\geq 91 + \log P_n$	30**	$\geq 97 + \log P_n$

* Including condensing boilers using liquid fuels

** Temperatures of the feed water of the boiler

Thermal plants

Heat generators

The heat generators can be distinguished according to the heat transfer medium (transfer) used in:

a) **generators with heat transfer fluid (called boilers)**

The thermal fluids used are:

- hot water and superheated

You differ according to the maximum temperature of the water used in the plant is respectively lower or higher than the boiling point to the local atmospheric pressure (see the phase diagram for the water of the figure).

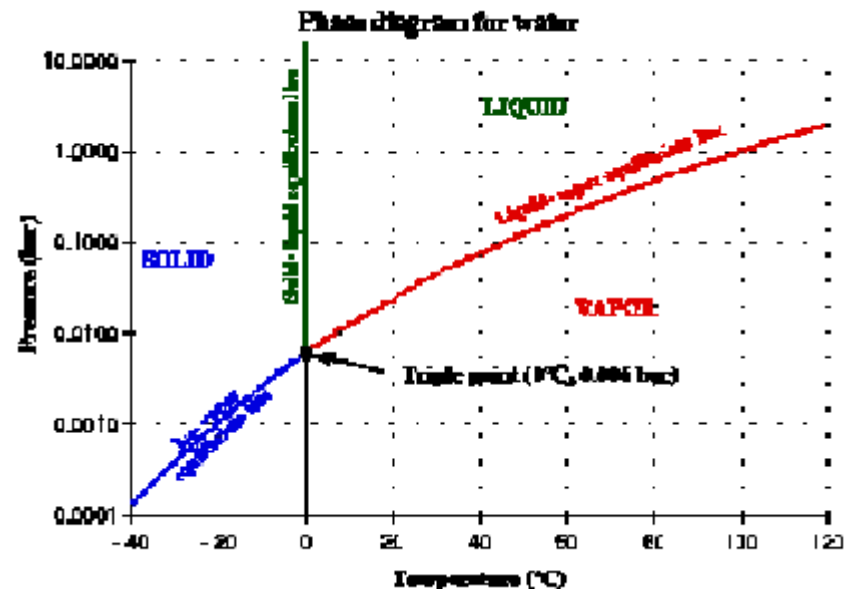

Thermal plants

Heat generators

The heat generators can be distinguished according to the heat transfer medium (transfer) used in:

a) generators with heat transfer fluid (called boilers)

The thermal fluids used are:

- hot water and superheated

The warm or hot water has the characteristics of being inexpensive compared to other transfer liquid, to require the chemical treatments of demineralization more so driven as higher are the temperatures involved and the normal temperatures of use are greater than 2-3°C to avoid freezing and lower than 180°C because otherwise the installation costs, and risks grow in a more than linear.



Thermal plants

Heat generators

The heat generators can be distinguished according to the heat transfer medium (transfer) used in:

a) generators with heat transfer fluid (called boilers)

The thermal fluids used are:

- diathermic fluid

They are able to remain in the liquid state at atmospheric pressure at temperatures higher than 100°C. They have the advantage, compared to the superheated water, allow the achievement of a very high temperature with pressures higher than atmospheric. They have high hazard (fire that may occur in systems with thermal oil, occurs mainly in the insulation, when they are made to perfection) and equipment costs much lower than traditional systems to water, while the cost of the transfer 5 to 20 times higher compared to the treated water.

Thermal plants

Heat generators

The heat generators can be distinguished according to the heat transfer medium (transfer) used in:

a) generators with heat transfer fluid (called boilers)

The thermal fluids used are:

- diathermic fluid

The heat transfer fluids used are mineral oils, chlorinated or silicates, and eutectic diphenyl with oxide of diphenyl (Dowtherm)

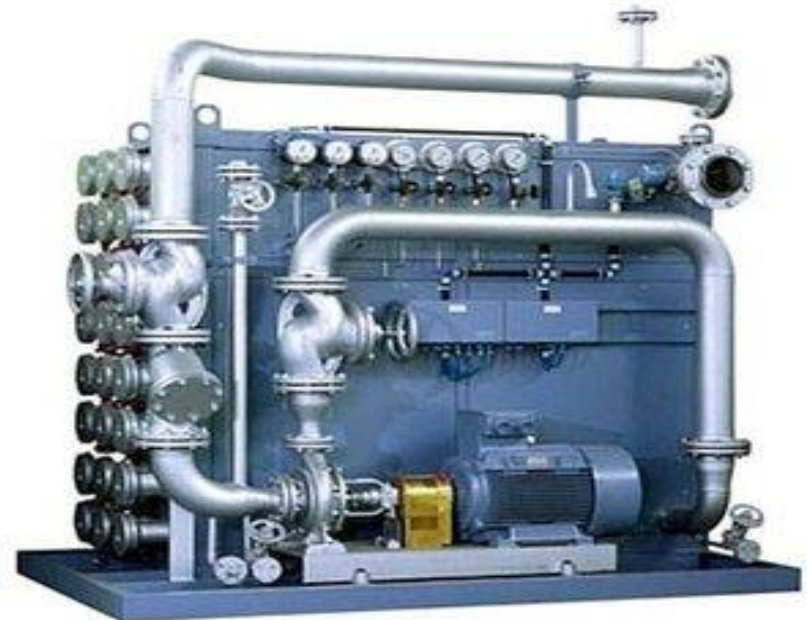
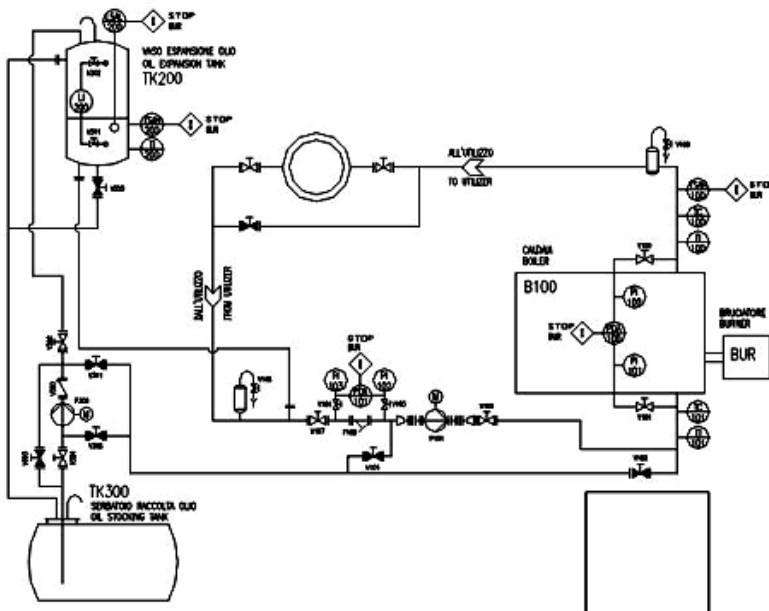

Thermal plants

Heat generators

The heat generators can be distinguished according to the heat transfer medium (transfer) used in:

a) generators with heat transfer fluid (called boilers)

The thermal fluids used are:

- vapor

It is a device that transforms chemical energy of a fuel into heat and makes it available in a circuit containing a liquid causing a change of state from liquid to gaseous, in a continuous manner and under controlled conditions.

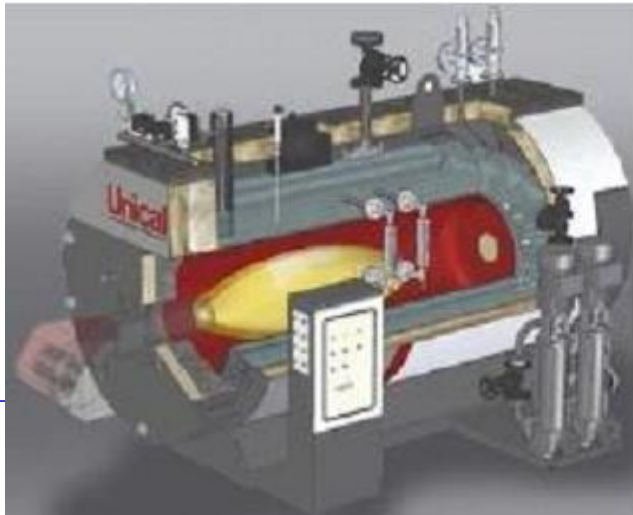

Thermal plants

Heat generators

The heat generators can be distinguished according to the heat transfer medium (transfer) used in:

a) **generators with heat transfer fluid (called boilers)**

The thermal fluids used are:

- vapor

In the steam generator, as in boilers, there are the following elements:

- the **fireside** or the **burner**, which constitute the input component of the thermal energy, which is a stoichiometric mixture almost perfectly between the carbon (or other element oxidized) in the fuel and the oxygen content in the air, so to achieve a flame such as to transmit the heat is by thermal conduction through the hot combustion fumes, both by radiation;

Thermal plants

Heat generators

The heat generators can be distinguished according to the heat transfer medium (transfer) used in:

a) **generators with heat transfer fluid (called boilers)**

The thermal fluids used are:

- vapor

In the steam generator, as in boilers, there are the following elements:

- the **combustion chamber**, which is the area where the combustion process takes place. The combustion chamber is usually in slight depression in the case of solid fuel; in the presence of a burner chamber is sometimes higher than the atmospheric pressure

Thermal plants

Heat generators

The heat generators can be distinguished according to the heat transfer medium (transfer) used in:

a) generators with heat transfer fluid (called **boilers**)

The thermal fluids used are:

- vapor

In the steam generator, as in boilers, there are the following elements:

- the **dome**, characteristic of the fire tube boilers, which is a plenum chamber in the upper part of the generator is obtained in which a gravity separation of water droplets from the steam, which are entrained by the steam itself

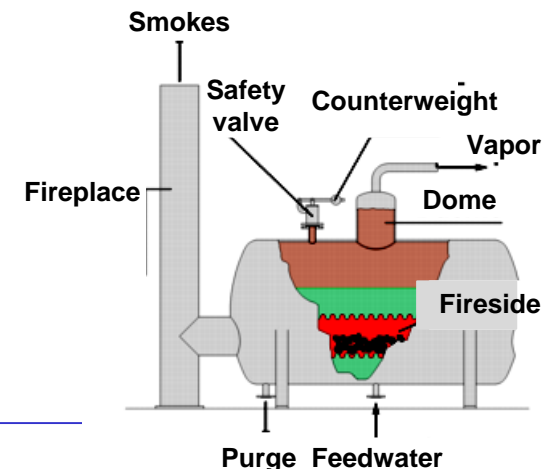
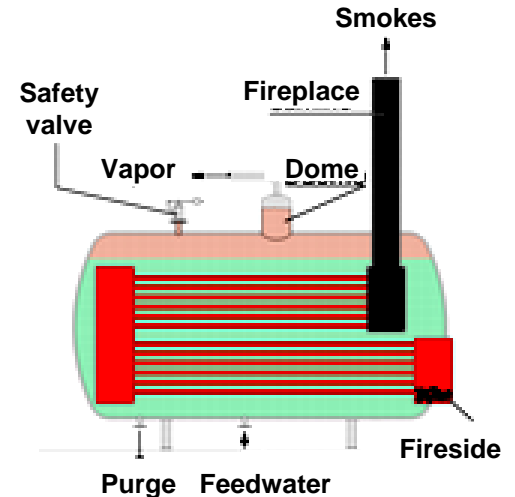

Thermal plants

Heat generators

The heat generators can be distinguished according to the heat transfer medium (transfer) used in:

a) **generators with heat transfer fluid (called boilers)**

The thermal fluids used are:

- vapor

In the steam generator there are the following elements:

- the **cylindrical body**, which in the fire tube boilers is the housing containing the boiler itself; in those water tube there is usually two or more, a lower one having the function of collector of the hot water not vaporized in order to facilitate the convective motion, and one or more higher, in one of which occurs the evaporation of the water (and the separation of water droplets drag) and the others have similar function to the lower one. In fire tube boilers, the function of the upper cylindrical body is carried from the dome. In water-tube boilers of marine type is common to put two cylindrical bodies one lower and one upper, due to the limited overall height which makes more difficult the convective motion;

Thermal plants

Heat generators

The heat generators can be distinguished according to the heat transfer medium (transfer) used in:

a) **generators with heat transfer fluid (called boilers)**

The thermal fluids used are:

- vapor

In the steam generator there are the following elements:

- the **tube bundle**, that is an assembly of tubes that connect, in the fire tube boilers, the hearth of the fireplace, and, in those water tube, the cylindrical bodies. The tube bundle has the function of increasing as much as possible the heat exchange surface between flue gas and water;
- the **fireplace**, external duct of evacuation of combustion fumes exhausted.

Thermal plants

Heat generators

The heat generators can be distinguished according to the heat transfer medium (transfer) used in:

a) **generators with heat transfer fluid (called boilers)**

The thermal fluids used are:

- vapor

In the steam generator there are the following elements:

- the **brickwork**, which is made up of different layers of clay materials (a layer of clay - refractory - a layer of clay - a insulating or insulating - a finishing layer carrier that can sometimes be replaced by metal panels or other covering);
- the **inspection doors** or **manhole covers**, to evacuate the ashes or visual inspection;

Thermal plants

Heat generators

The heat generators can be distinguished according to the heat transfer medium (transfer) used in:

a) **generators with heat transfer fluid (called boilers)**

The thermal fluids used are:

- vapor

In the steam generator there are the following elements:

- the **superheater**, to transform the saturated water vapor further dry heat so as to increase the temperature at constant pressure and use that heat in the steam turbine for the production of electrical energy;

Thermal plants

Heat generators

The heat generators can be distinguished according to the heat transfer medium (transfer) used in:

a) **generators with heat transfer fluid (called boilers)**

The thermal fluids used are:

- vapor

In the steam generator there are the following elements:

- the **economizers**, recovering the residual heat at low temperature, which allows the preheating of the feed water and combustion air, so as to reduce the sensible heat to be supplied to these, to the detriment of the heat used to vaporize.

Thermal plants

Heat generators

The heat generators can be distinguished according to the heat transfer medium (transfer) used in:

a) generators with heat transfer fluid (called boilers)

The thermal fluids used are:

- vapor

The steam generators you can classified according:

- a) the content of fluid in relation to the exchange surface;
- b) the partition type (generator tubes of fluid/generator smoke pipes);
- c) the natural or forced circulation of the fluid;
- d) the energy carrier used for the generation (combustion, nuclear, solar) and the dependence of its availability by generation (CHP or special);

Thermal plants

Heat generators

The heat generators can be distinguished according to the heat transfer medium (transfer) used in:

a) generators with heat transfer fluid (called boilers)

The thermal fluids used are:

- vapor

The steam generators you can classified according:

- e) the maximum operating pressure (atmospheric, pressure, depression);
- f) the flow of steam;
- g) the mobility of the installation, fixed, semi-fixed (monoblock generator tankless), locomobile (monoblock generator with tank trailer without engine, used for example in the pipeline), locomotive (integrated with a steam engine).

Thermal plants

Heat generators

The heat generators can be distinguished according to the heat transfer medium (transfer) used in:

a) generators with heat transfer fluid (called boilers)

The thermal fluids used are:

- vapor

With reference to the volume of water with respect to the heating surface (classification) steam generators can be distinguished in:

- a large volume of water (130 to 250 dm³/m²);
- a medium volume of water (from 70 to 130 dm³/m²);
- a small volume of water (less than 70 dm³/m² of surface area).

Thermal plants

Heat generators

The heat generators can be distinguished according to the heat transfer medium (transfer) used in:

a) generators with heat transfer fluid (called boilers)

The thermal fluids used are:

- vapor

With reference to the path of the fumes (classification b), the steam generators can be distinguished in:

- steam generators tubes of water;
- steam generators tubes of smoke;
- water tube boilers with a combustion chamber with vertical development.

Thermal plants

Heat generators

The heat generators can be distinguished according to the heat transfer medium (transfer) used in:

a) generators with heat transfer fluid (called boilers)

The heat generators used are:

Water tube boilers with combustion chamber with vertical development:
sono un tipo di caldaia in cui l'acqua circola in tubi riscaldati esternamente dai fumi di combustione e sono utilizzate per le caldaie ad alta pressione. Il combustibile è bruciato all'interno della camera di combustione (focolare o bruciatore) creando gas caldo, che riscalda l'acqua che circola nei tubi trasformandosi in vapore, che confluisce in un cilindro. Inoltre, potendo usare tubi più piccoli e tortuosi, si creano maggiori superfici di scambio, ottenendo così caldaie più piccole a parità di produzione.

Thermal plants

Heat generators

The heat generators can be distinguished according to the heat transfer medium (transfer) used in:

a) generators with heat transfer fluid (called boilers)

The heat generators used are :

Water tube boilers with combustion chamber with vertical development:

they have further advantages such as the reduced volume of water, which enables a much more rapid start-up, and smaller size of pressure parts (lower thicknesses). In some types the steam will fall into the combustion chamber through a superheater and the superheated steam is used to drive the steam turbine for the production of electricity.

They have a potentiality of between 60 and 1200 MW.

Thermal plants

Heat generators

The heat generators can be distinguished according to the heat transfer medium (transfer) used in:

a) generators with heat transfer fluid (called boilers)

The heat generators used are:

Water tube boilers with combustion chamber with vertical development

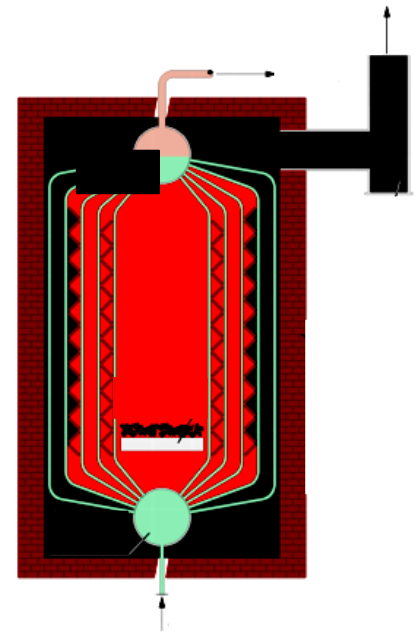
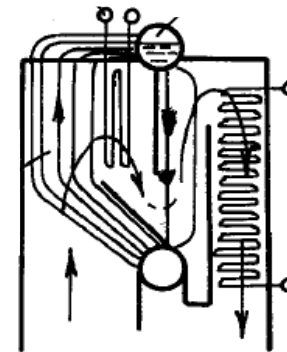
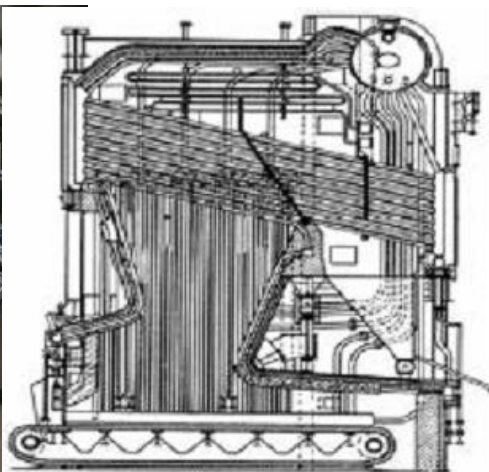
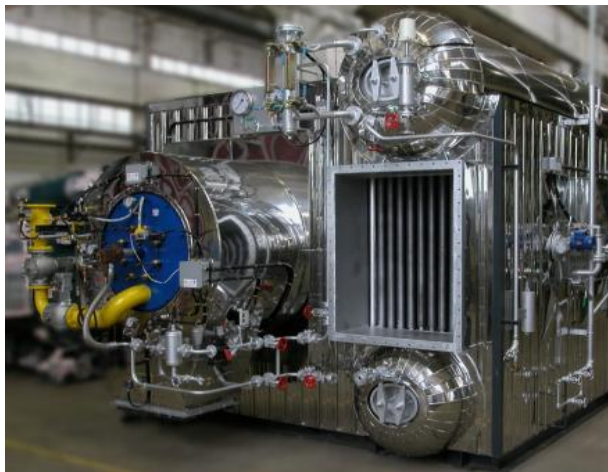

Thermal plants

Heat generators

The heat generators can be distinguished according to the heat transfer medium (transfer) used in:

a) generators with heat transfer fluid (called boilers)

The heat generators used are:

Water tube boilers with combustion chamber with horizontal development: are similar to the previous, present a lower potentiality of between 6 and 120 MW. These boilers can have yields of up to 94% and pressures up to 100 bar. They have a lower hazard with respect to the generators smoke pipes

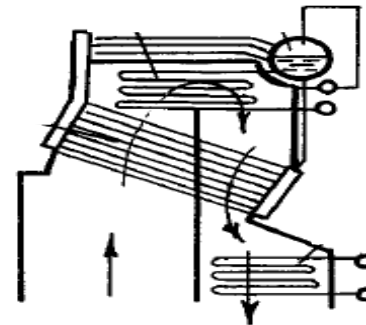

Thermal plants

Heat generators

The heat generators can be distinguished according to the heat transfer medium (transfer) used in:

a) **generators with heat transfer fluid (called boilers)**

The heat generators used are:

Boilers at pipes smoke: are boilers in which the hot fumes resulting from the combustion process are channeled in a bundle of tubes immersed in water, which is then heated by convection. They have a lower potential of between 0.6 and 15 MW.

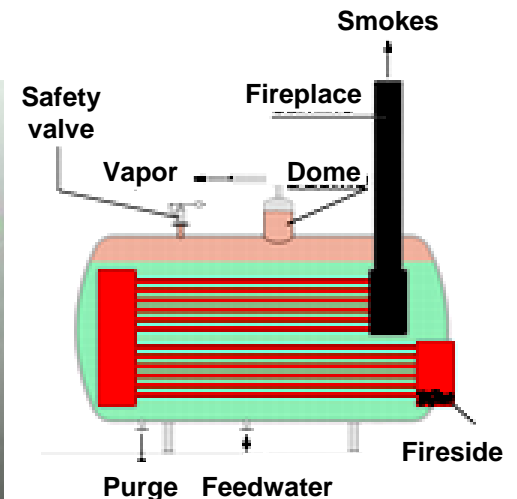
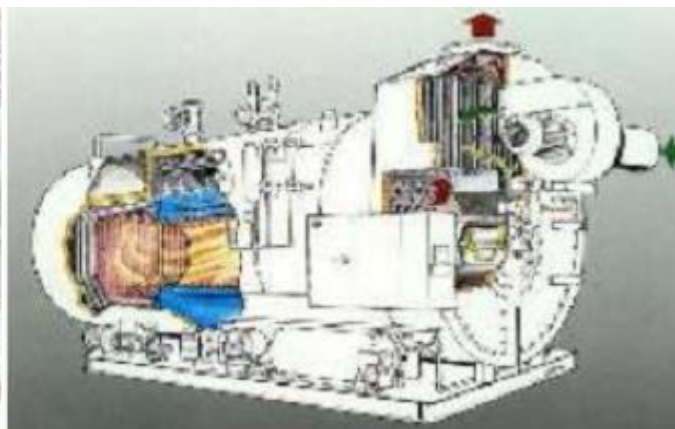

Thermal plants

Heat generators

The heat generators can be distinguished according to the heat transfer medium (transfer) used in:

a) generators with heat transfer fluid (called boilers)

The heat generators used are:

Boilers at pipes smoke: in some applications there are three rounds of smoke. The hot gases of combustion, after passing through the hearth, reverse their bikes entering the first tube bundle (2nd round). Joints in the front of the generator, the fumes undergo a second inversion in the reversing chamber front and start off the tubes placed in the upper part of the boiler (3rd round). You can obtain the characteristics shown in the table.

Round	Area of the tubes (m ²)	Temperature (°C)	Heat transferred (%)
First	11	1600	65
Second	11	400	25
Third	11	300	10

Thermal plants

Heat generators

The heat generators can be distinguished according to the heat transfer medium (transfer) used in:

a) generators with heat transfer fluid (called boilers)

The heat generators used are:

Boilers at pipes smoke: in some applications there are three rounds of smoke.

They have yields between 85 and 88% and pressures up to 16 bar. Are cheaper than water-tube boilers (on equal terms), but require more maintenance and are potentially more dangerous.

Thermal plants

Heat generators

The heat generators can be distinguished according to the heat transfer medium (transfer) used in:

a) generators with heat transfer fluid (called boilers)

The heat generators used are:

Boilers at crossing or at forced circulation (according to the classification c)



Thermal plants

Heat generators

The heat generators can be distinguished according to the heat transfer medium (transfer) used in:

a) generators with heat transfer fluid (called boilers)

The heat generators used are:

Boilers at crossing or at forced circulation (according to the classification c)

In boilers operating at high pressures, not wanting to proportion the screen section of the tubes so as to obtain low pressure loss, it helps the circulation pumps by inserting in the circuit, so as to provide water pressure required to overcome the passive resistance and ensure a correct and constant movement in the pipes.

They present a potential minor between 60 kW and 250 MW.

Thermal plants

Heat generators

The heat generators can be distinguished according to the heat transfer medium (transfer) used in:

a) generators with heat transfer fluid (called boilers)

The heat generators used are:

Boilers at crossing or at forced circulation (according to the classification c)

The pumps are called circulation pumps of boiler (PCC figure) and the circulation system takes the name of movement, controlled or assisted. The prevalence of these pumps is only that necessary to supplement the natural circulation.



Thermal plants

Heat generators

The heat generators can be distinguished according to the heat transfer medium (transfer) used in:

b) heat generators with gaseous transfer

They can be divided into:

Hot air generators

They allow you to transfer the heat of combustion to users without polluting the transfer gas (usually air). In this case it realizes an exchange smoke-metal-transfer gaseous mainly by convection.



Thermal plants

Heat generators

The heat generators can be distinguished according to the heat transfer medium (transfer) used in:

b) heat generators with gaseous transfer

They can be divided into:

Hot air generators

Typical products are the air heaters for heating the environment (temperatures between 55 and 75°C), heat treatment furnaces (hardening, tempering etc.) with radiating elements, which reach 1000-1200°C in an atmosphere controlled.



Thermal plants

Heat generators

The heat generators can be distinguished according to the heat transfer medium (transfer) used in:

b) heat generators with gaseous transfer

They can be divided into:

Heaters direct

In which the products of combustion, for example LPG, are mixed with the transfer or themselves constitute a heat transfer fluid, possibly diluted with air.



Thermal plants

Heat generators

The heat generators can be distinguished according to the heat transfer medium (transfer) used in:

b) heat generators with gaseous transfer

They can be divided into:

Heaters direct

They allow to reduce the investment, the cost of maintenance, the overall dimensions, the consumption of electrical energy, the heat losses in the environment and the thermal energy contained in the system. You must use high-grade fuels and expensive (methane and GPL) because there must be no harmful substances in the combustion products.

It must, however, achieve almost perfect combustion, combustion with excess air such that the flow rates have 50-700 times the stoichiometric amount, such as to enter the air flow at a temperature slightly higher than ambient.

Thermal plants

Heat generators

The heat generators can be distinguished according to the heat transfer medium (transfer) used in:

b) heat generators with gaseous transfer

They can be divided into:

Heaters direct

They yields around the unit, speed of air flowing inside the same around the 25 m/s, there is a footprint of peak usage which restricts the potential of these systems, the limited time of passage to scheme (maximum 10 s)

Thermal plants

Heat generators

The heat generators can be distinguished according to the heat transfer medium (transfer) used in:

b) heat generators with gaseous transfer

They can be divided into:

Drying plants

It is an evaporative process aimed to the removal of a liquid (usually water) from a solid substance (typically porous). The process usually consists in the removal of moisture from a solid substance through the use of warm, dry air which, by breaking the surface, evaporates the water contained in it (for example drying process of green bricks)



Thermal plants

Heat generators

The heat generators can be distinguished according to the heat transfer medium (transfer) used in:

b) heat generators with gaseous transfer

They can be divided into:

Drying plants

In the processes of drying, the heat can be transferred in three ways:

- convection: when the heat is transferred from one point to another of a fluid through the mixing of portions of the same fluid at different temperatures (for example hot air is replacing cold air in a desiccator static);
- conduction: transfer of heat from one body to another by direct contact (wet material on a hot metal surface);
- radiation: heat transfer between two bodies not in contact with electromagnetic radiation

Thermal plants

Heat generators

The heat generators can be distinguished according to the heat transfer medium (transfer) used in:

b) heat generators with gaseous transfer

They can be divided into:

Drying plants

In reality, these mechanisms can occur simultaneously and variously combined in various types of installations. The following equation describes the rate of evaporation of water (dw/dt) as a function of the quantity of heat transferred (q , where q_c is the heat by convection, q_r is the heat by radiation and q_k is the heat conduction), A is the area of the evaporation surface, h is the absolute humidity at the material surface (h_s) and in the air (h_g). In addition, λ is the latent heat of evaporation of water and K the coefficient of mass transfer:

$$\frac{dw}{dt} = \frac{q_c + q_r + q_k}{\lambda} = K \cdot A \cdot (h_s - h_g)$$

Thermal plants

Heat generators

The heat generators can be distinguished according to the heat transfer medium (transfer) used in:

b) heat generators with gaseous transfer

They can be divided into:

Drying plants

The process of artificial drying can take place:

- for indirect heating: is interposed a heat exchange surface between the product and the transfer. Is used when the solid product requires special conditions of hygiene (for example the production of milk powder);

Thermal plants

Heat generators

The heat generators can be distinguished according to the heat transfer medium (transfer) used in:

b) heat generators with gaseous transfer

They can be divided into:

Drying plants

The process of artificial drying can take place :

- for direct heating (with warm air, cold air, with combustion products, by irradiation): the transfer most common is the hot air, but when the substance to be treated is not a food product, you can also use products combustion (eg fumes of the oven baking of the bricks which is recovered and sent in the drying of "green bricks") with consequent energy savings. When the product can not tolerate high temperatures using cold air previously dried;

Thermal plants

Heat generators

The heat generators can be distinguished according to the heat transfer medium (transfer) used in:

b) heat generators with gaseous transfer

They can be divided into:

Drying plants

The process of artificial drying can take place:

- for radiant heating is the typical case of rotary dryers direct flame, in which a naked flame heats by radiation the solid-liquid mixture, which then evaporates. The irradiation with infrared lamps is used for the drying of coatings.

Thermal plants

Heat generators

The heat generators can be distinguished according to the heat transfer medium (transfer) used in:

b) heat generators with gaseous transfer

They can be divided into:

Drying plants

They are divided into:

- *drying plants static*

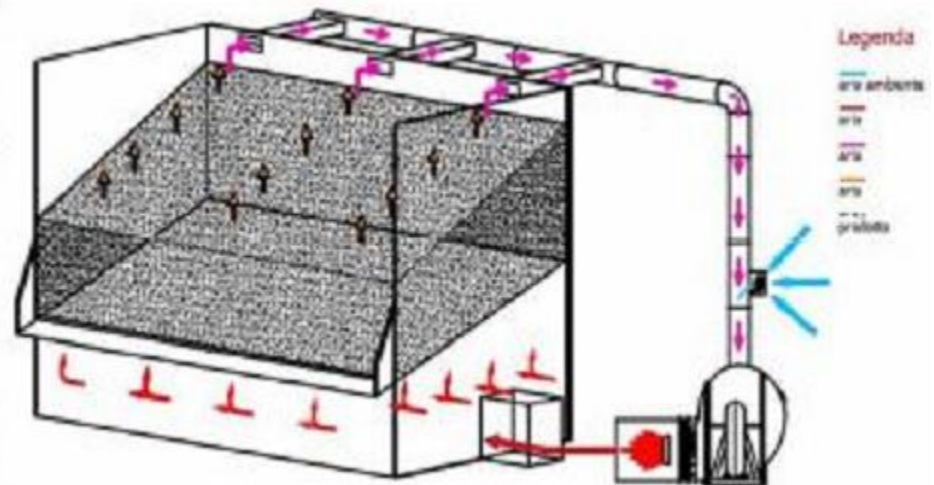

Thermal plants

Heat generators

The heat generators can be distinguished according to the heat transfer medium (transfer) used in:

b) heat generators with gaseous transfer

They can be divided into:

Drying plants

They are divided into:

- *drying plants static*

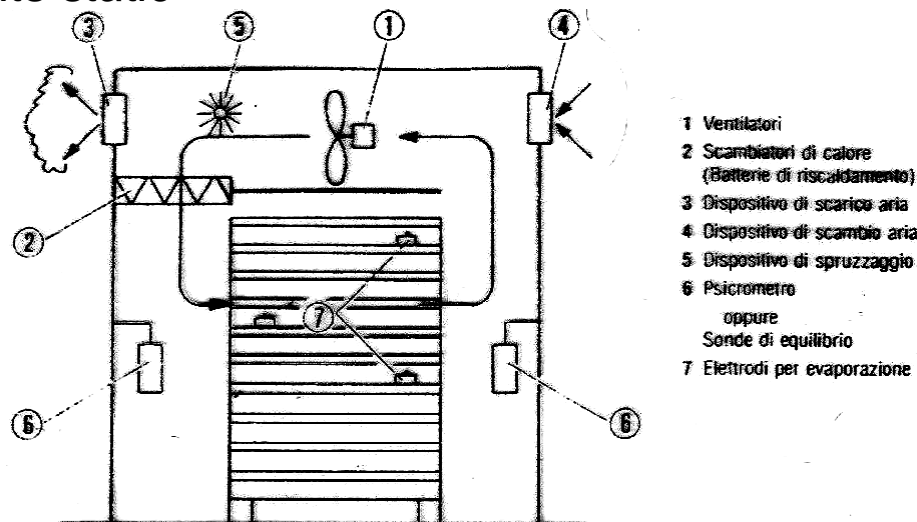

Thermal plants

Heat generators

The heat generators can be distinguished according to the heat transfer medium (transfer) used in:

b) heat generators with gaseous transfer

They can be divided into:

Drying plants

They are divided into:

- *drying plants static*

They consist of large metal casings where the material is dried by circulating hot air, which is heated by electrical resistors or by steam circulating in appropriate tubes. The material to be dried is placed in thin layer on shelves or stacked trays; the circulation of air between the trays is forced by openings in the walls and can be made more efficient by a fan which increases the speed. They are discontinuous systems suitable for small-medium production of dried material

Thermal plants

Heat generators

The heat generators can be distinguished according to the heat transfer medium (transfer) used in:

b) heat generators with gaseous transfer

They can be divided into:

Drying plants

They are divided into:

- *drying plants continuous*



Thermal plants

Heat generators

The heat generators can be distinguished according to the heat transfer medium (transfer) used in:

b) heat generators with gaseous transfer

They can be divided into:

Drying plants

They are divided into:

- *drying plants continuous*

The material, transported on a conveyor or a chain conveyor in slow motion, enters and exits the dryer after a certain residence time, during which occurs the evaporation of moisture by contact with hot air. The tape is normally in the network to promote contact of hot air with the material to be dried.

Thermal plants

Heat generators

The heat generators can be distinguished according to the heat transfer medium (transfer) used in:

b) heat generators with gaseous transfer

They can be divided into:

Drying plants

They are divided into:

- *drying plants continuous*

There is the possibility of having a rotating cylindrical drier in which a hollow metal cylinder is slightly inclined, which rotates slowly on its axis and having in its interior of radial baffles. The material to be dried is introduced from above, and is kept in constant motion by the motion of the cylinder and by the presence of the septa (the material progresses slowly climbing the inner surface of the cylinder and falling down by gravity). In this way it encourages contact with the hot air that enters in countercurrent and drying the product.

Thermal plants

Heat generators

The heat generators can be distinguished according to the heat transfer medium (transfer) used in:

b) heat generators with gaseous transfer

They can be divided into:

Drying plants

They are divided into:

- *drying plants continuous*

This type of dryer is efficient, but can not be used for substances that are very thermolabile



Thermal plants

Heat generators

The heat generators can be distinguished according to the heat transfer medium (transfer) used in:

b) heat generators with gaseous transfer

They can be divided into:

Drying plants

They are divided into:

- *drying at fluid bed*

The process involves investing from the bottom upwards with a jet of hot air of adequate power a set of solid particles, these are raised and are suspended in the gas. It forms a fluid mixture in which the individual particles are completely surrounded by gas molecules. In this way the water evaporation and drying of the product takes place in a very short time. These driers are suitable for the treatment of granular materials incoherent

Thermal plants

Heat generators

The heat generators can be distinguished according to the heat transfer medium (transfer) used in:

b) heat generators with gaseous transfer

They can be divided into:

Drying plants

They are divided into:

- *drying at fluid bed*

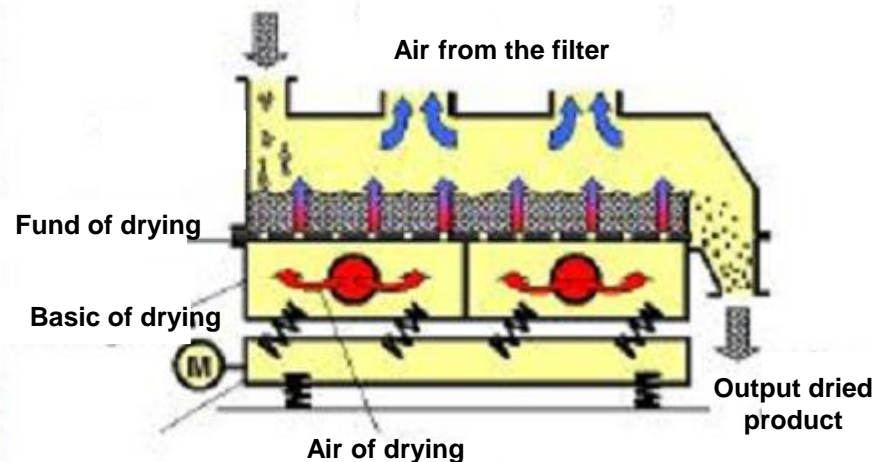

Thermal plants

Heat generators

The figure shows the range of application of heat generators.

