

dissolution **D**ynamic **N**uclear **P**olarization

method for obtaining strongly
polarized nuclear spins in solution

Increase in signal-to-noise ratio of >10,000 times in liquid-state NMR

*J. H. Ardenkjær-Larsen, B. Fridlund, A. Gram, G. Hansson, L. Hansson, M. H. Lerche,
R. Servin, M. Thaning, K. Golman PNAS 2003, 100, 10158–10163*

The method uses

- low temperature,
- high magnetic field,
- dynamic nuclear polarization (DNP) to strongly polarize nuclear spins
- in the solid state (glass).

HyperSense - the in-vitro DNP Polariser

3.35 T magnet

sold by Oxford Instruments

can be coupled to any commercial superconducting NMR spectrometer

easy switch from normal to hyperpolarized mode

since 2012

Hyperpolarization signifies a spin polarization that deviates strongly from thermal equilibrium.

<https://www.oxford-instruments.com/products/spectrometers/nuclear-magnetic-resonance-nmr/hypersense>



DNP polarizer

superconducting magnet (3.35 T)

the sample is contained in a variable temperature insert, VTI, (inside the magnet cryostat, which was modified) cooled at 1.2 K by liquid helium (pumped below the inversion T).

placed in the resonator (microwaves at 94 GHz)

spectrometer

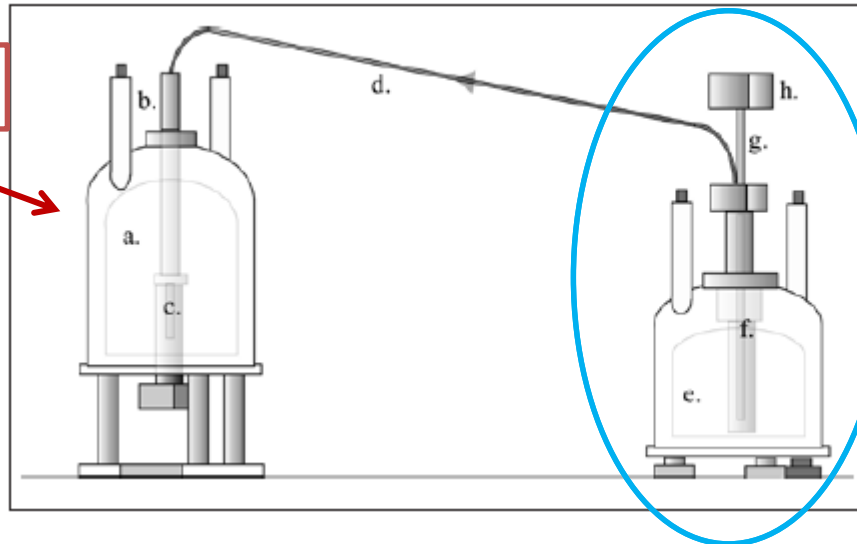
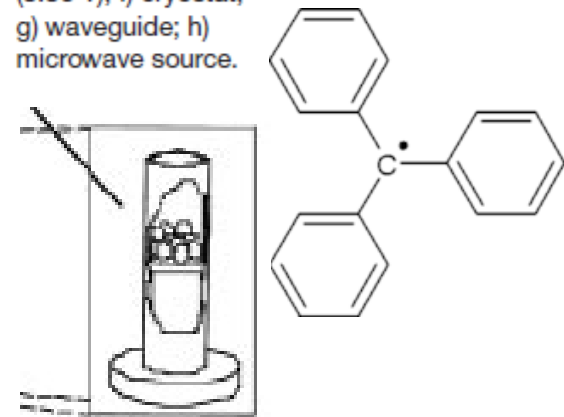

Fig. 4. Dissolution DNP setup, a) NMR cryomagnet (7.05 T); b) polarized solution injector; c) NMR tube sitting in the NMR probe; d) PTFE transfer line; e) DNP cryomagnet (3.35 T); f) cryostat; g) waveguide; h) microwave source.

Sample

^{13}C urea solution in glycerol (29% wt/wt nearly saturated) and tritylradical (15/20 mM)

40–50 mg of the solution was dispensed as droplets into liquid nitrogen and transferred to the sample container as frozen pellet



sample container with sample beads

Loading the sample

1. the sample holder and container are pre-cooled in a nitrogen bath (the sample holder is a Teflon tube designed to hold the sample container in position in the magnetic field and subsequently to enable the elevation of the sample before dissolution)
2. the frozen pellets are placed in the container via an opening in the sample holder,
3. the sample holder is lowered into the variable temperature insert, into the liquid He
4. the VTI evacuated to 0.8 mbar to cool the sample to 1.2 K

Polarization

Dissolution of the sample

Dissolution-DNP is based on the notion that a 1 K “ice cube” can be dissolved in a fraction of a second or short on T_1 time scale

1. Soon after stopping mw irradiation by pressurizing the system the sample is raised 10 cm from the magnetic center to leave the liquid helium (magnetic field 3 T)
2. hot water is injected to dissolve and dilute the sample (inside the polarizer magnet)

Electron and Nuclear Polarization at Low Temperature

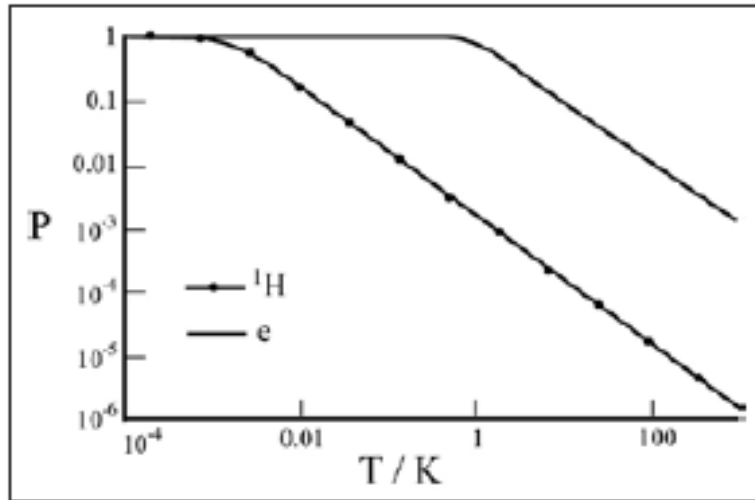

Fig. 1. Polarization of the 1/2 spins of the electron (plain line) and of the ¹H nucleus (line with dots) as a function of the temperature in Kelvin at 3.35 T.

$$P = \frac{\exp\left(-\frac{1}{2}\gamma \frac{\hbar B_0}{kT}\right) - \exp\left(\frac{1}{2}\gamma \frac{\hbar B_0}{kT}\right)}{\exp\left(-\frac{1}{2}\gamma \frac{\hbar B_0}{kT}\right) + \exp\left(\frac{1}{2}\gamma \frac{\hbar B_0}{kT}\right)}$$

For very low T the truncation of the series expansion is not allowed

At 1.2 K e- polarization is full, that of nuclei not yet

The maximum nuclear spin polarization is still only 1.5×10^{-3} at 1 K

NMR of Insensitive Nuclei Enhanced by Dynamic Nuclear Polarization

P. Miéville, S. Jannin, L. Helm, G. Bodenhausen *Chimia* 65 (2011) 260–263

Polarizing the Sample

The sample is irradiated over 15 min to 4 hours with microwaves at a frequency of 94 GHz in the 3.35 T magnetic field. The build-up of the nuclear spin polarization can be observed by 'small angle' pulsed NMR.

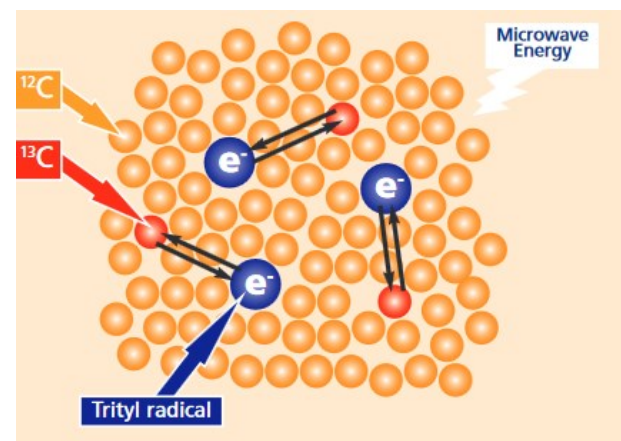
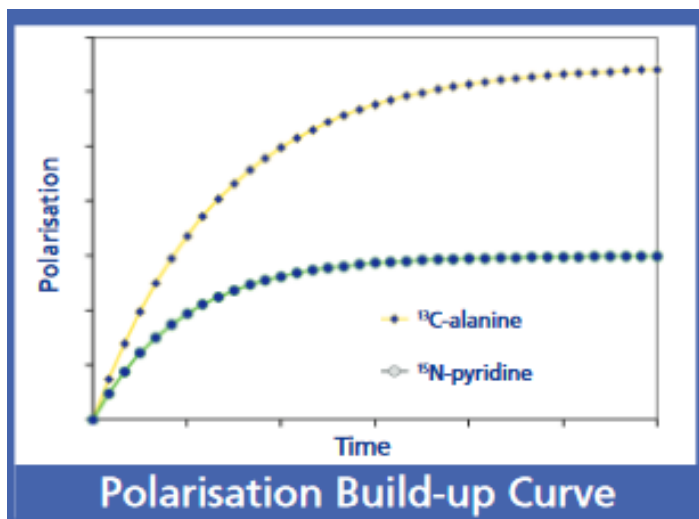

polarization build up is slow at low T

long relaxing nuclei are required (quaternary carbons, ^{15}N)

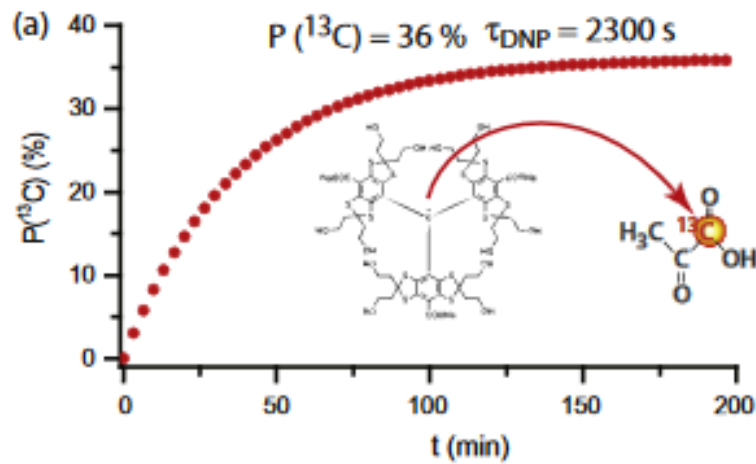

Typical DNP build-up of 1-¹³C pyruvic acid with 15 mM trityl at 1.2 K and 3.35 T

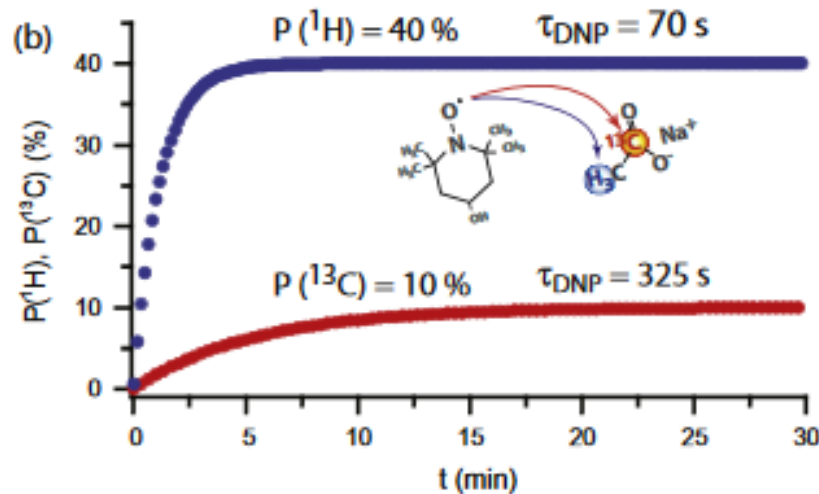

The build up is faster for ¹H

It is advantageous to polarize ¹H and then transfer the polarization to ¹³C by means of cross-polarization

Fig. 1. (a) Typical DNP build-up of 1-¹³C pyruvic acid with 15 mM trityl at 1.2 K and 3.35 T [9]. (b) Typical ¹H (blue) and ¹³C (red) DNP build-up curves of 3 M 1-¹³C acetate with 30 mM TEMPO in D₂O:glycerol-d₈ (1:1) at 1.2 K and 3.35 T [29,30]. (For interpretation of the references to color in this figure legend, the reader is referred to the web version of this article.)

Optimizing dissolution dynamic nuclear polarization

A. Bornet, S. Jannin J. Magn. Reson. 2016, 264, 13-21

Overhauser DNP Enhancement

Overhauser DNP was theoretically predicted in 1953 [Overhauser] and subsequently experimentally observed in ammonia-dissolved alkali-metals [Slichter]

$$\frac{M_{ZI(ss)} - M_{ZI(0)}}{M_{ZI(0)}} = f s \left| \frac{\gamma_S}{\gamma_I} \right| (W_2 - W_0) / (W_2 + 2W_{1I} + W_0)$$

- I: nucleus
max: -359 for pure dipolar interaction:
0.5* ratio of gyromagnetic ratios
- S: electron
- $0 \leq s \leq 1$: **saturation factor** describes the efficiency of microwave pumping, depends on microwave power and e- relaxation
- f: **leakage factor** $R_{1para} / (R_{1para} + R_{1dia})$ reflects the relative importance of the relaxation of the nucleus by the interaction with the e- with respect to the overall relaxations pathways of the nucleus
- the correlation time may be the e- relaxation time

Transfer to the NMR Spectrometer

The dissolution process effectively preserves nuclear polarization.

The resulting hyperpolarized liquid sample is transferred to a high-resolution NMR spectrometer, where an enhanced NMR signal can be acquired, or it may be used as an agent for *in vivo* imaging or spectroscopy

NMR Measurement of the Hyperpolarized Sample

The polarization is often created ex situ, and therefore that cannot be recreated to the initial state. It is a game of “use it (smart), or lose it”.

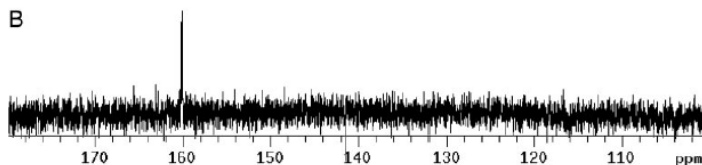
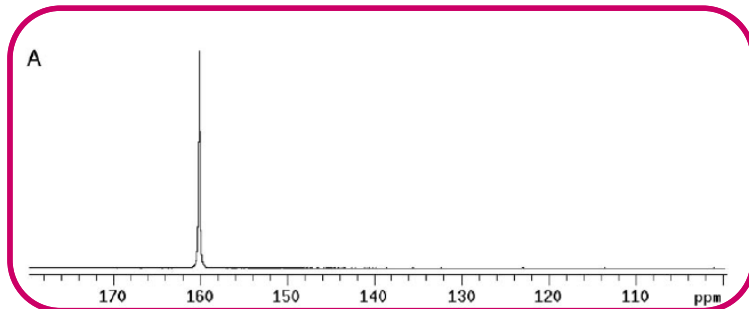

¹³C natural abundance urea that was polarized to 20%: a 24,000-fold enhancement over 9.4 T.

The thermal spectrum on the same sample took 65 h to acquire with a thousand-fold lower SNR. 27 years of averaging would have been required to reach the same SNR.

It is possible a kinetic study using short pulses, e.g. 10°

Hyperpolarization is suited to directed
detected heteronuclear correlation

2D NMR Ultrafast Experiments: 2D hetero-
correlations in a **single scan**

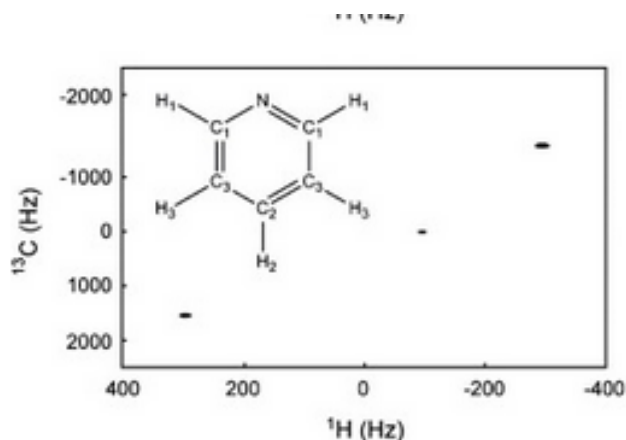

pyridine 3 mM

HyperSPASM NMR: A New Approach to Single-Shot 2D Correlations on DNP-
Enhanced Samples

K. J. Donovan, L. Frydman J. Magn. Reson. 2012, 225, 115-119

07.12.16 - EPFL's Institute of Chemical Sciences and Engineering (ISIC) has installed an

NMR SYSTEM WITH THE HIGHEST SENSITIVITY AND RESOLUTION IN THE WORLD



<https://actu.epfl.ch/news/epfl-installs-world-unique-nmr-system-6/>

Optically Generated Hyperpolarization

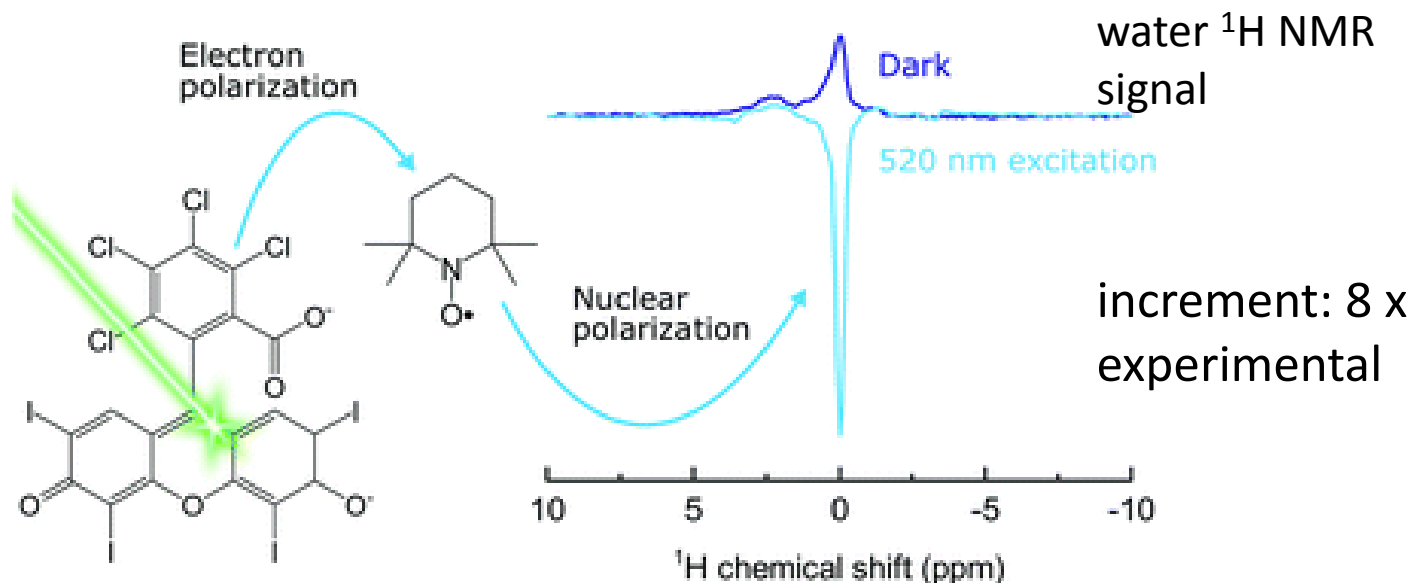

Photogenerated triplet state in a diradical by green laser radiation

Coupling of the e- triplet spin state with a e- doublet spin state gives a quartet and a doublet

Optically generated hyperpolarization for sensitivity enhancement in solution-state NMR spectroscopy M. W. Dale, C. J. Wedge Chem. Commun. 2016, 52, 13221-13224