

LECTURE 6

THE RNAi MACHINERY AND REGULATION OF HETEROCHROMATIN

Small ncRNA and gene/chromatin regulation

micro-RNAs = miRNAs

short interfering RNAs = siRNAs

miRNAs and siRNAs are generated by the same machinery

1. Long precursor RNA
1. Processing into small RNAs by Type 3 RNase Dicer
siRNAs and miRNAs (21-23 nt) still double-stranded
3. Processing by RISC complex
(RNA induced silencing complex)
4. guide RNA → regulatory RNA
passenger RNA → will be eliminated
5. RISC complex+guide RNA → regulatory function
 - A. RNA degradation = siRNA effect (cutting = "slicing")
 - B. inhibition of mRNA translation = mRNA effect
 - C. transfer to nucleus and chromatin regulation = siRNA mediated silencing

miRNAs: always "trans"-acting on mRNAs
siRNAs: mostly "cis" acting on chromatin (S-pombe)

NO
miRNAs
in yeast

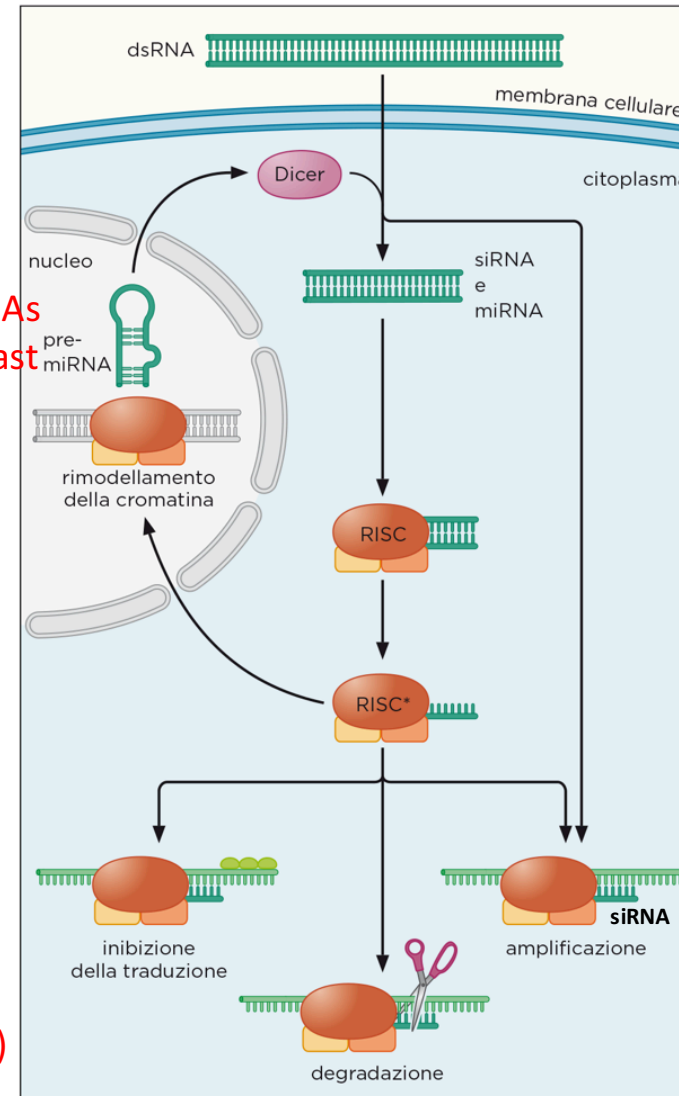

RNA dependent RNA polymerase amplifies siRNAs

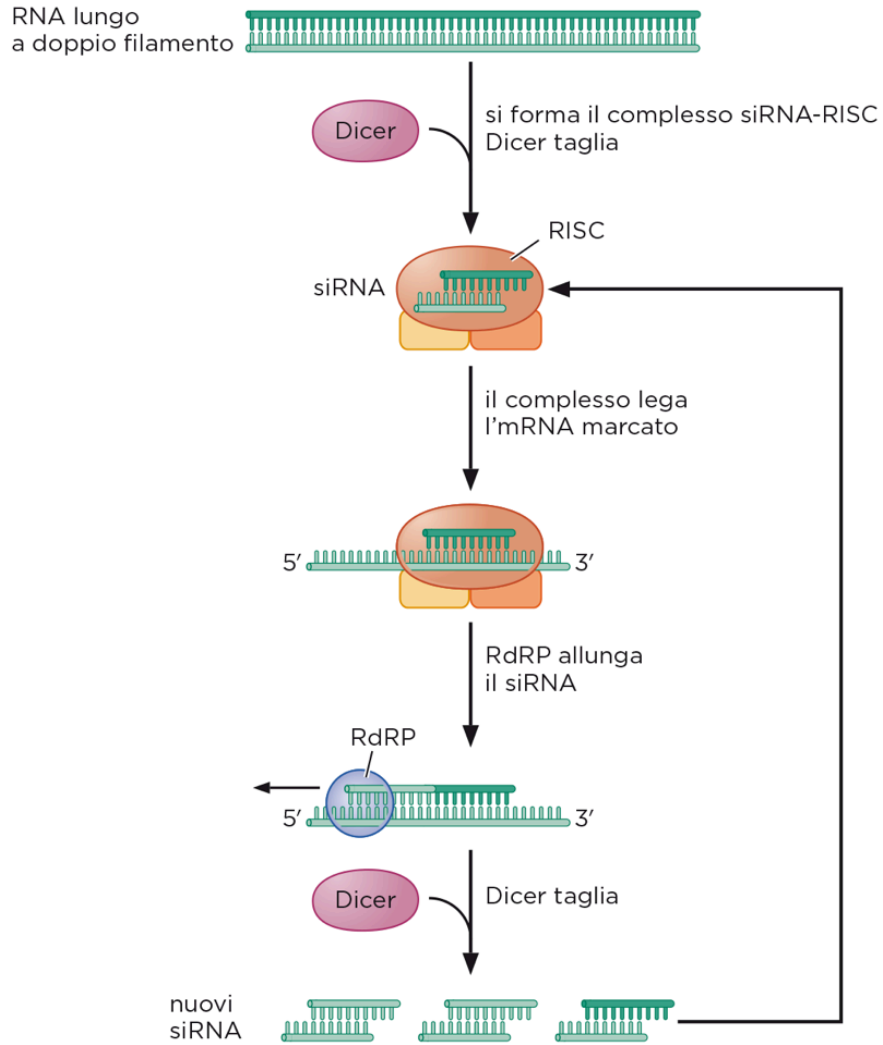

In plants, *S. pombe*, nematodes, human,
NOT IN *S. CEREVISIAE*

NO RNA dependent RNA polymerase in Vertebrates

siRNAs as endogenous

epigenetic regulators

The first model for siRNAs and chromatin regulation (induction): *S. pombe*: siRNA mediated chromatin regulation (silencing)

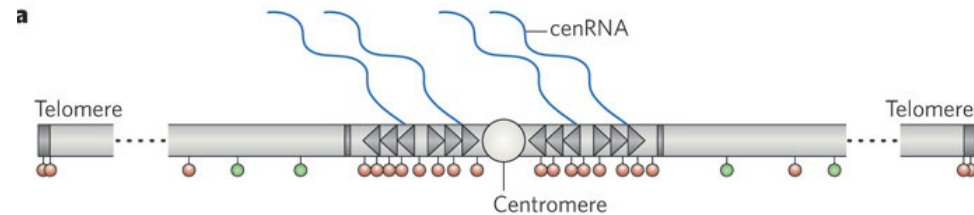
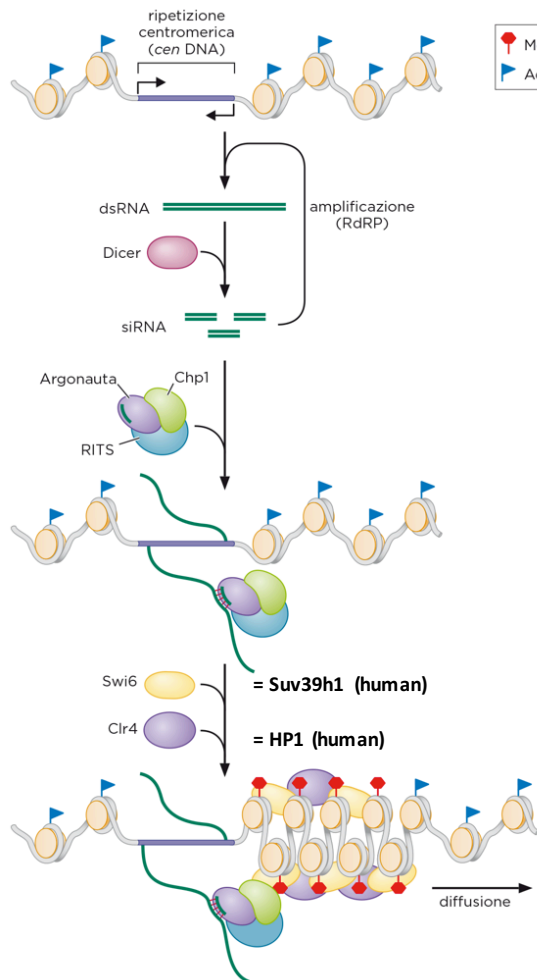

Centromeres in *S. pombe*:

- Heterochromatin (H3K9me3, Clr4 (HP1))
- Reporter genes inserted: repression

-Discovery:

RNAi mutant result in loss of H3K9m3/Clr4 and reactivation of reporter gene that was inserted into centromeric region
=RNAi mediated gene silencing

Eukaryotic centromeres

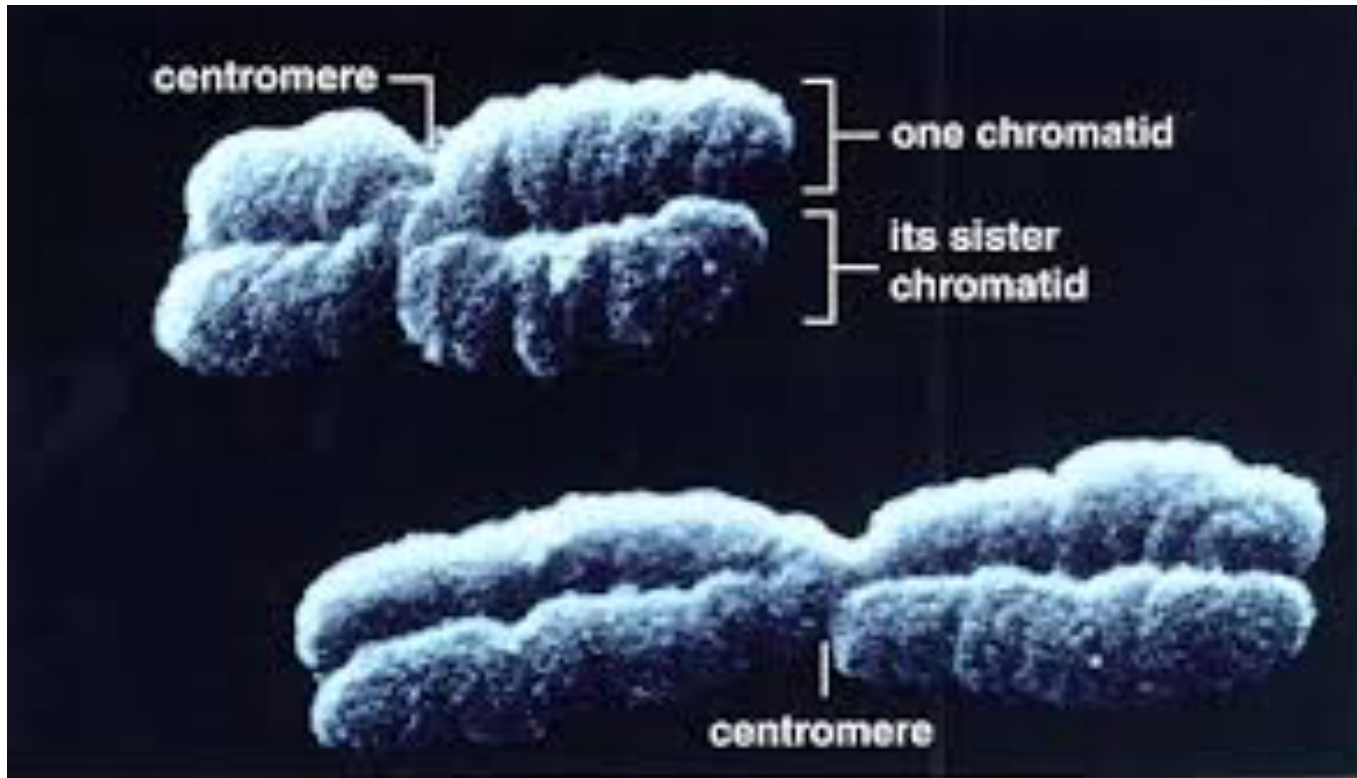

Eukaryotic centromeres

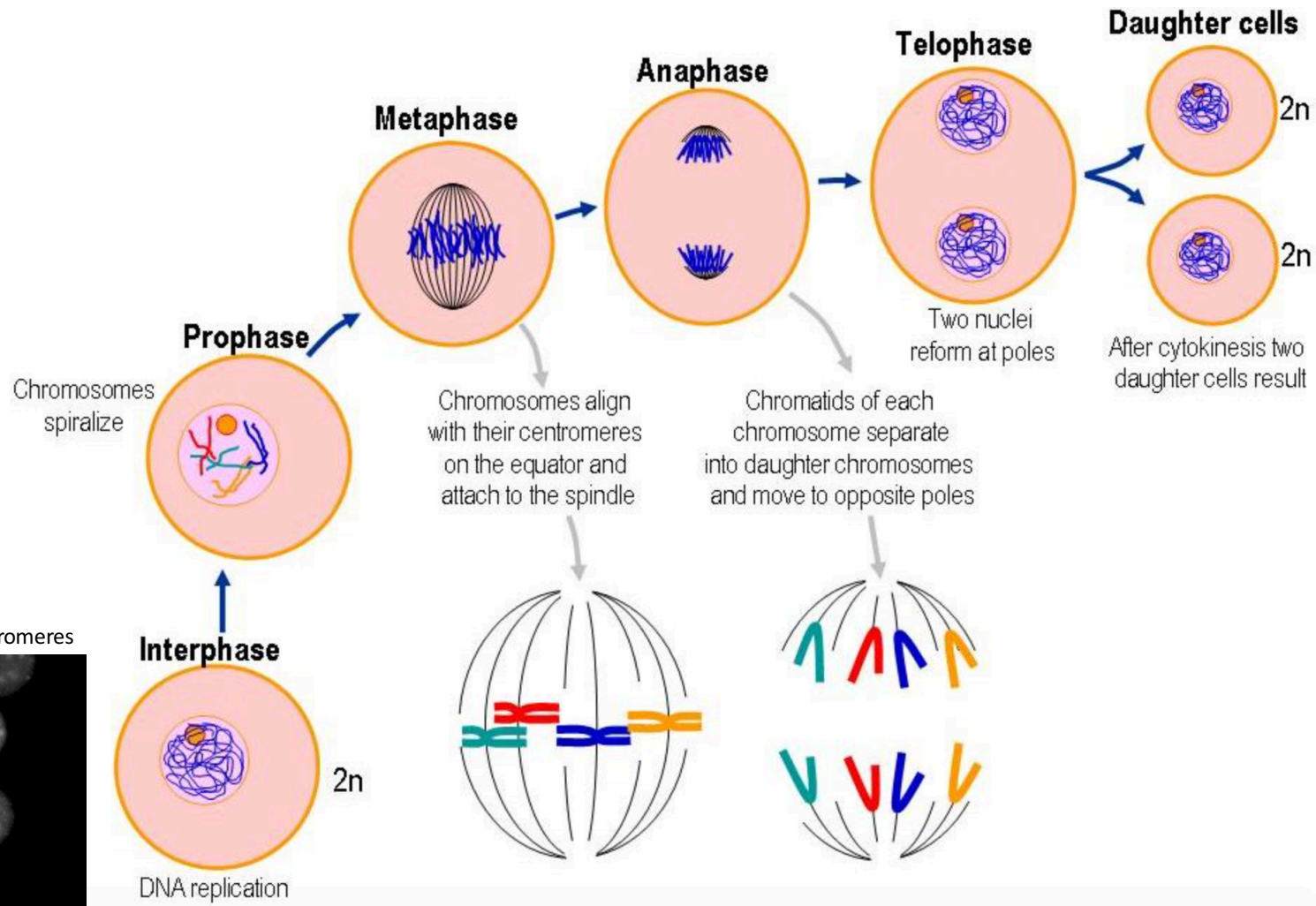

Chromocenters, aggregation of centromeres

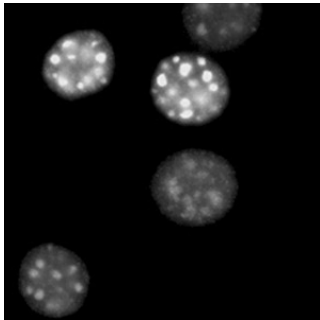

Functional regions at centromeres

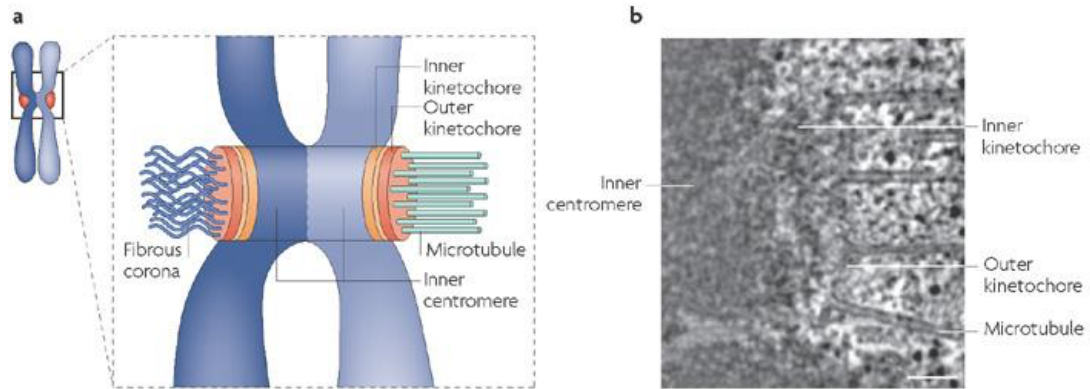

Nature Reviews | Molecular Cell Biology

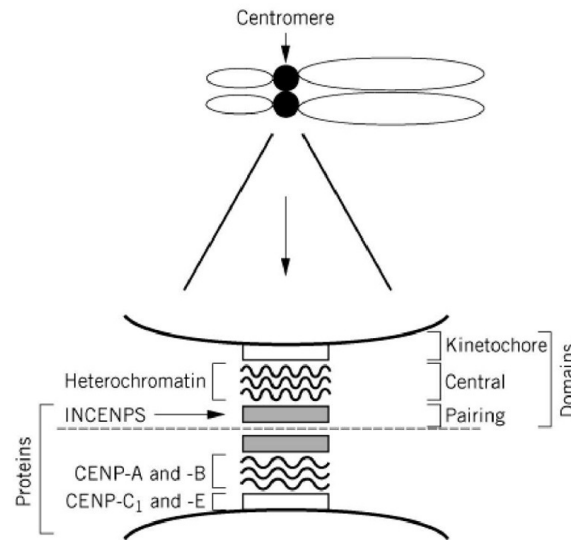

Centromeric DNA consists of constitutive heterochromatin

Centromere structure in diverse organisms

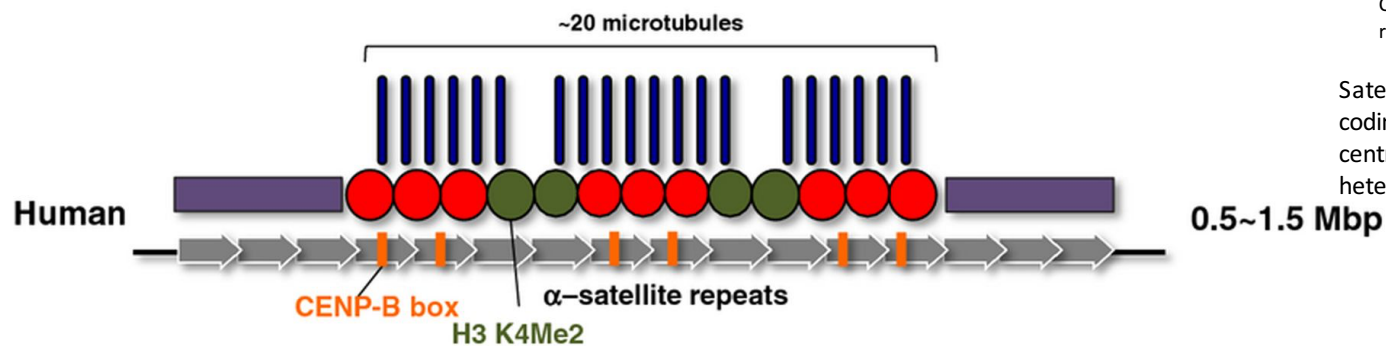
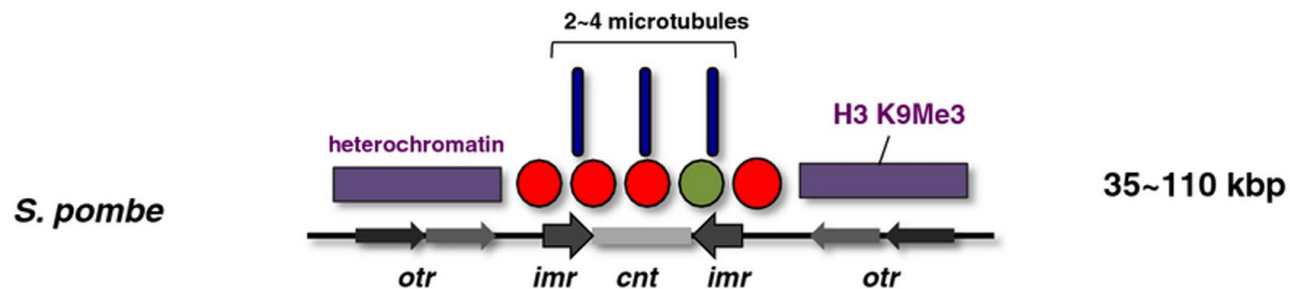
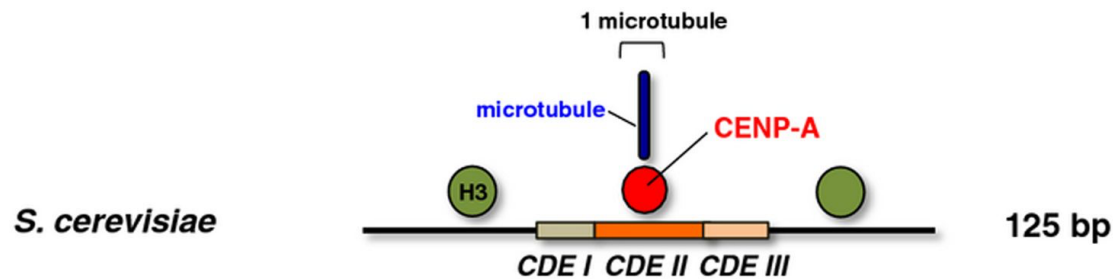

The CENPA gene encodes a centromere protein which contains a histone H3 related histone fold domain that is required for targeting to the centromere. CENPA is proposed to be a component of a modified nucleosome or nucleosome-like structure in which it replaces 1 or both copies of conventional histone H3 in the (H3-H4)₂ tetrameric core of the nucleosome particle.

Diversity of centromeric structure and CENP-A nucleosome distribution among eukaryotes.

Schematic representation of centromeres in budding yeast (*Saccharomyces cerevisiae*), fission yeast (*Schizosaccharomyces pombe*) and human.

1. Budding yeast has a point centromere, which is defined by a 125-bp sequence and is occupied by a single CENP-A containing nucleosome. There are three conserved elements in budding yeast CEN DNA: CDE (centromere DNA element) I, CDEII and CDEIII
2. *Schizosaccharomyces pombe* and human have regional centromeres that are flanked by pericentromeric heterochromatin. In *Schizosaccharomyces pombe*, a multiple number of CENP-A (Cnp1)-containing nucleosomes are assembled onto unique sequences (cnt – centromeric sequence and imr – innermost repeats). Pericentric, heterochromatic repeats are called “outer repeats” (otr)
3. Human centromeres consist of α -satellite DNA arranged in tandem into higher order repeats (each arrow), and some α -satellite DNA contains CENP-B binding sites (CENP-B box). CENP-A localizes to a portion of these arrays. The number of microtubule attachment sites also varies among organisms. CENP-B is a highly conserved centromere protein in mammals and binds to a 17-bp motif in a CENP-B box. It has been shown that α -satellite DNA with a CENP-B box is responsible for de novo centromere assembly in human somatic cells.

Satellite DNA consists of very large arrays of tandemly repeating, non-coding DNA. Satellite DNA is the main component of functional centromeres, and form the main structural constituent of heterochromatin.

Centromere structure in *S.pombe*

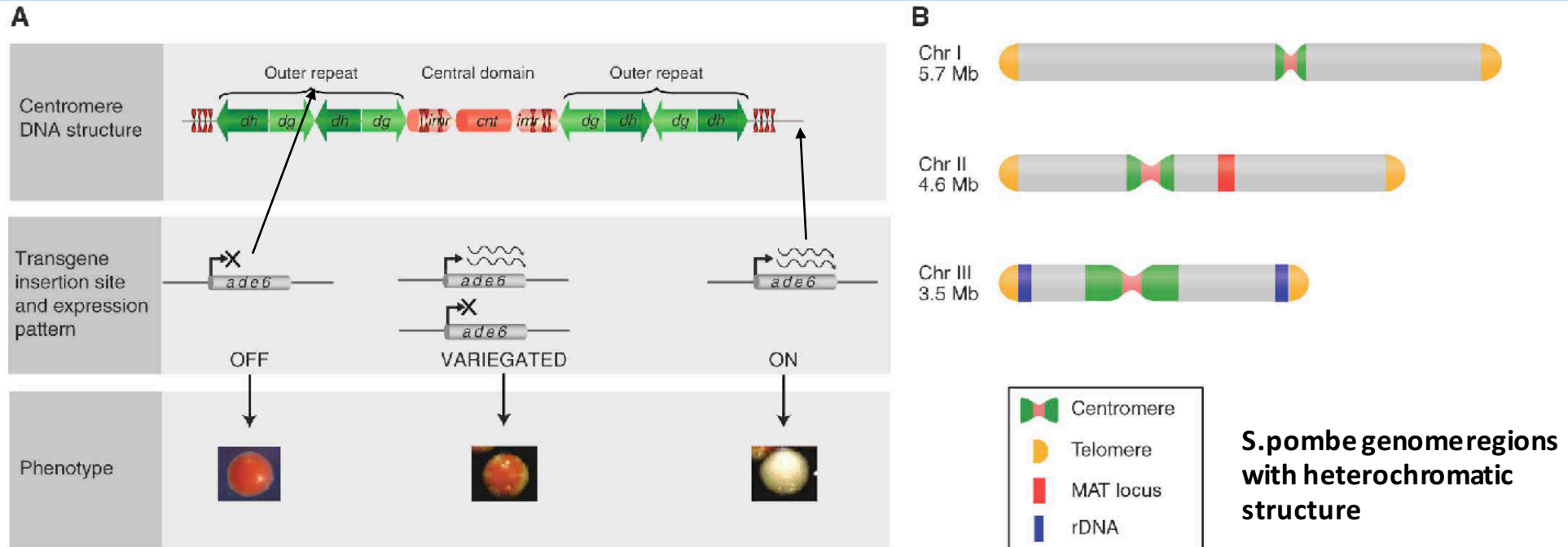

Figure 2. Distinct outer repeat heterochromatin and central kinetochore domains at fission yeast centromeres. (A, top) Representation of a fission yeast centromere. The central domain (pink, kinetochore) is composed of *imr* and *cnt* elements, the outer repeats contain transcribed *dg* and *dh* repeats (green, heterochromatin). All three centromeres have a similar overall arrangement; however, the number of outer repeats differs: *cen1* (40 kb) has two, *cen2* (65 kb) has three, and *cen3* (110 kb) has approximately 13. Clusters of transfer RNA (tRNA) genes (double arrowheads) occur in the *imr* region and at the extremities of all three centromeres. (Middle) Schematically shows transcription patterns of marker genes placed within the outer repeats, central domain, or beyond the centromere. (Bottom) Images showing the phenotype of *S. pombe* colonies of *ade6*⁺ transgenics inserted at various sites within the centromere. Cells expressing *ade6*⁺ from a transgene inserted in sequences outside the centromere form white colonies. When *ade6*⁺ is inserted at sites within the outer repeats, expression is silenced and red colonies are formed. Expression of *ade6*⁺ from the central domain is typically variegated, resulting in red, white, and sectorial colonies. (B) A schematic representation of *S. pombe* chromosomes. The three chromosomes are depicted showing the four main regions of heterochromatin: centromere, telomere, *mat2/3*, and rDNA regions.

Ade6 reporter gene system to measure chromatin structure:

When expressed - euchromatin: white colony

When silenced - heterochromatin: red colony

Ura4 reporter system: Ura4 converts agent to toxin → cell dies when Ura3 is expressed

Ade6 mutants in *S.pombe* (ADE2 in *S. cerevisiae*) generate red-colored intermediates of the adenine biosynthesis pathway

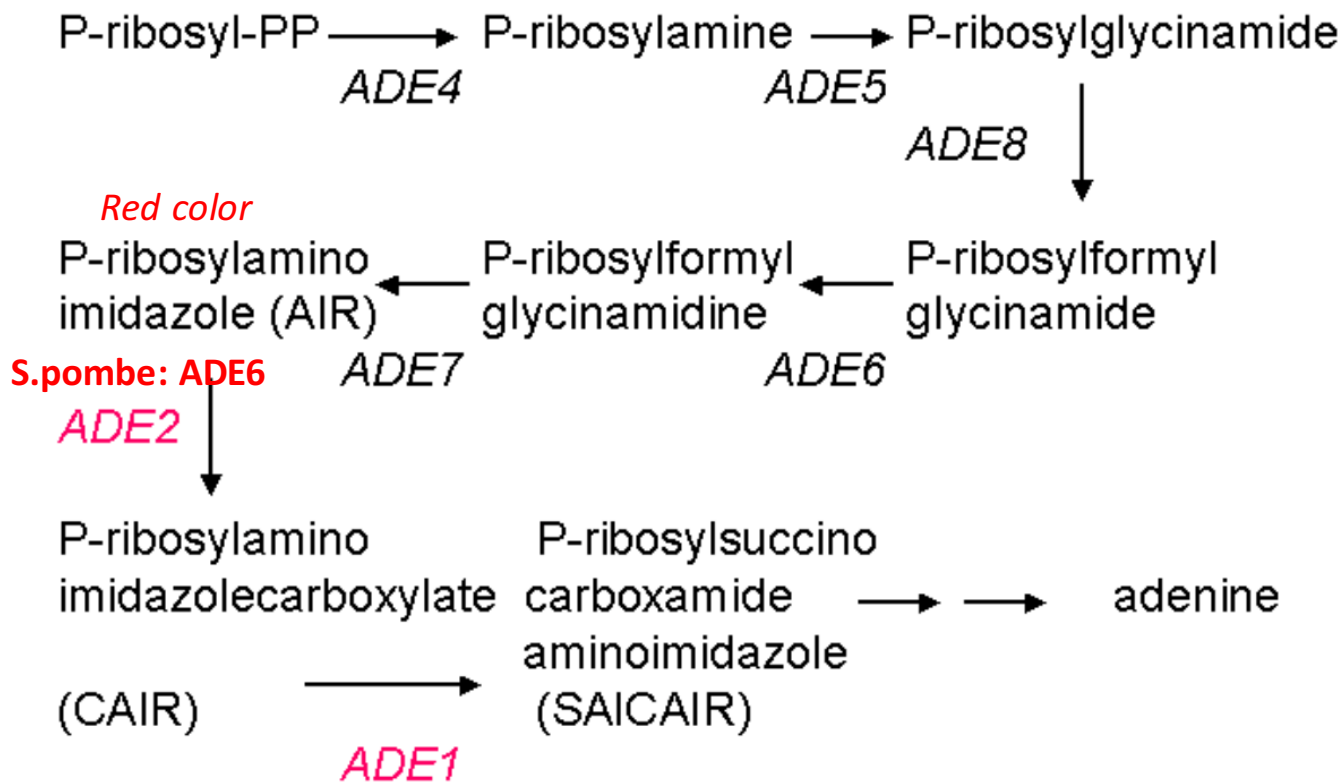

S. pombe

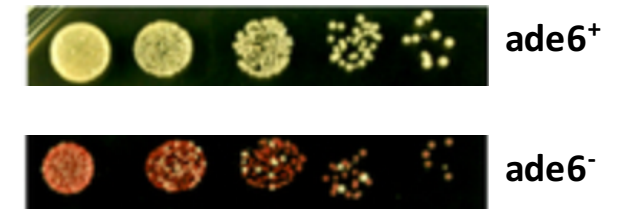

Strategy:

Generate *S.pombe* strain with Ade6 mutation.

Re-introduce Ade6 maker into the genome.

If located in euchromatin: White colony

If located in heterochromatin: Red colony

The adenine biosynthesis pathway in *S.cerevisiae*

Centromere structure in *S.pombe*

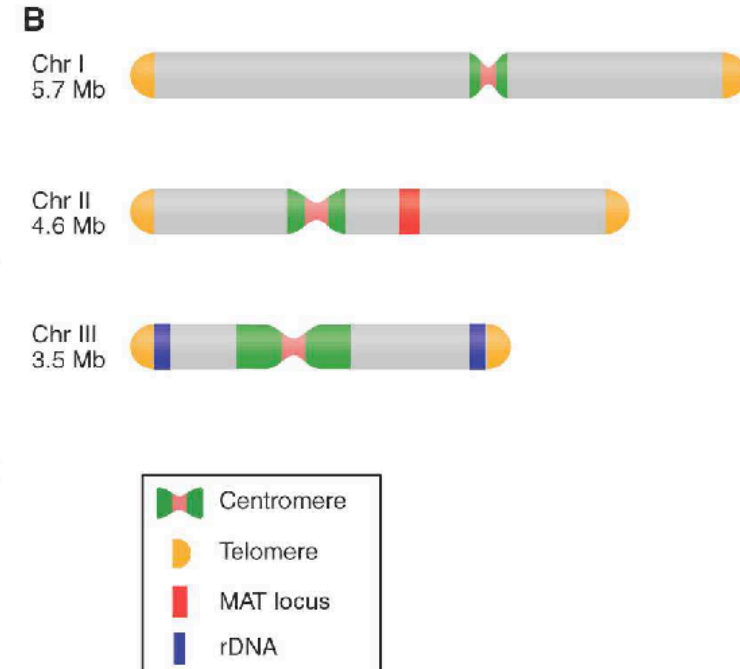
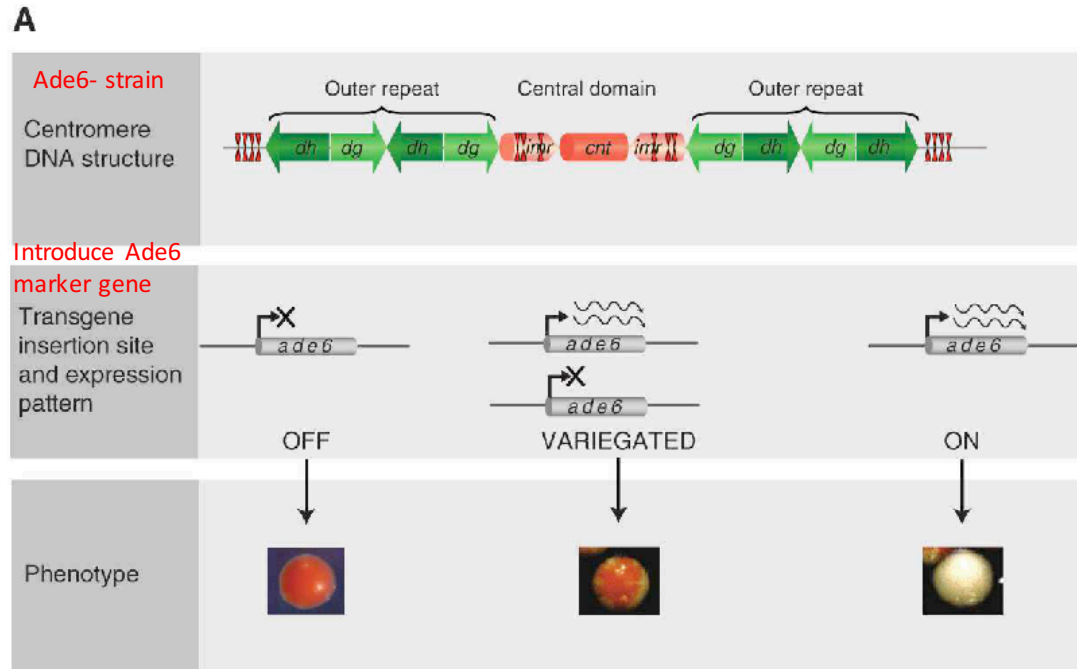

Centromeric heterochromatin structure depends on:

- RNAi proteins
- RNA polymerase
- Epigenetic writer: Clr4 (Suv39h1/2 homolog)
- H3K9me3
- Chp1 (HP1) homolog

NO DNA METHYLATION SYSTEM IN *S. pombe*

Centromere structure in *S.pombe*

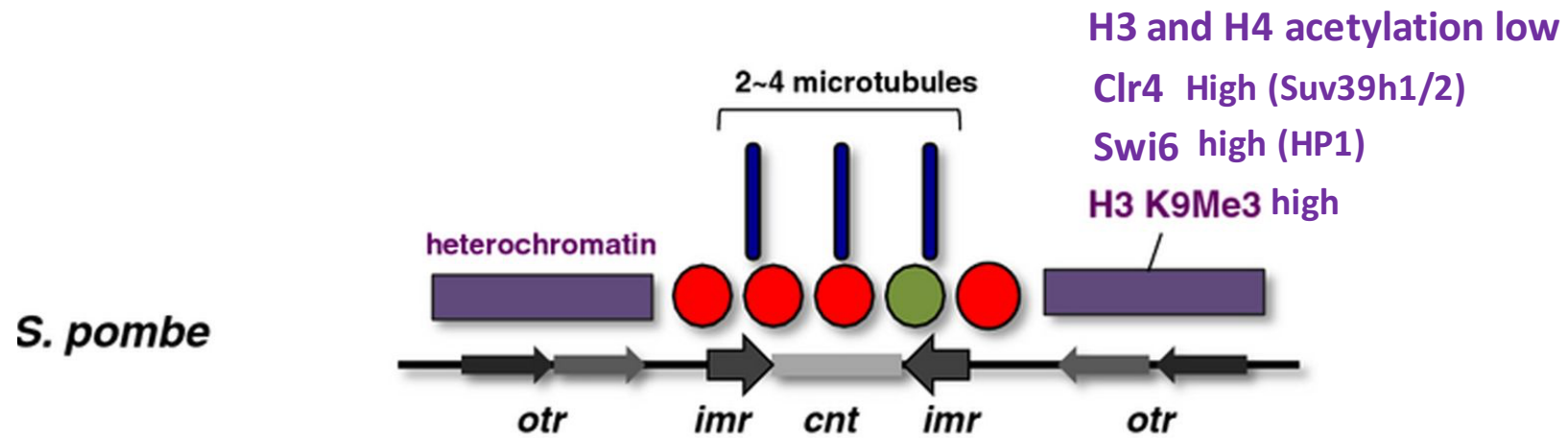

Centromere structure in *S.pombe*

S. pombe

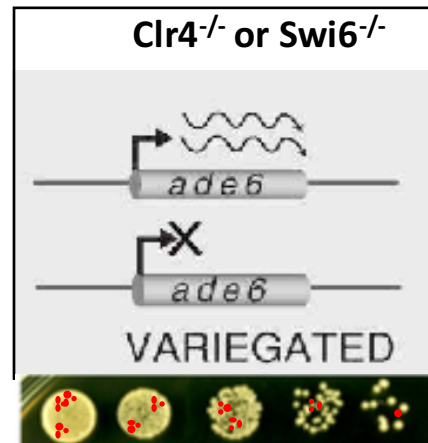
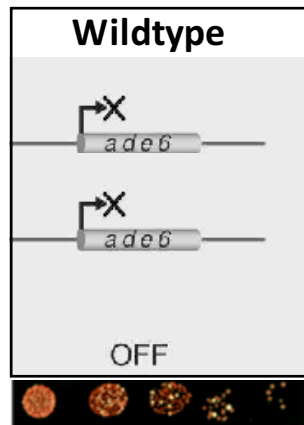
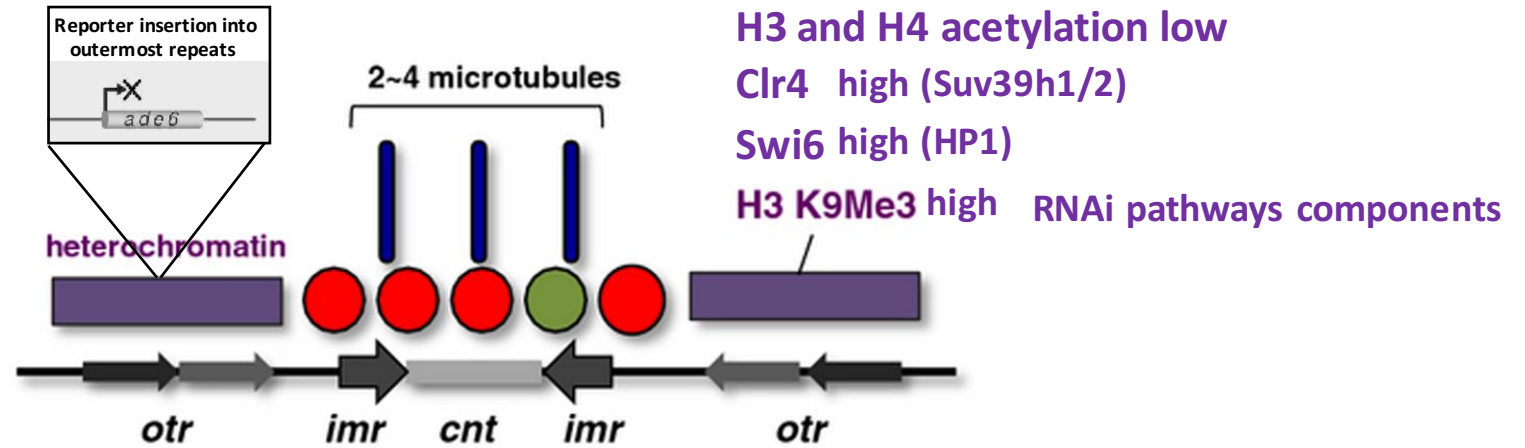

How is heterochromatin recruited to centromeres??

BUT ALSO IN RNAi MUTANTS

Sources of RNAs for siRNA generation

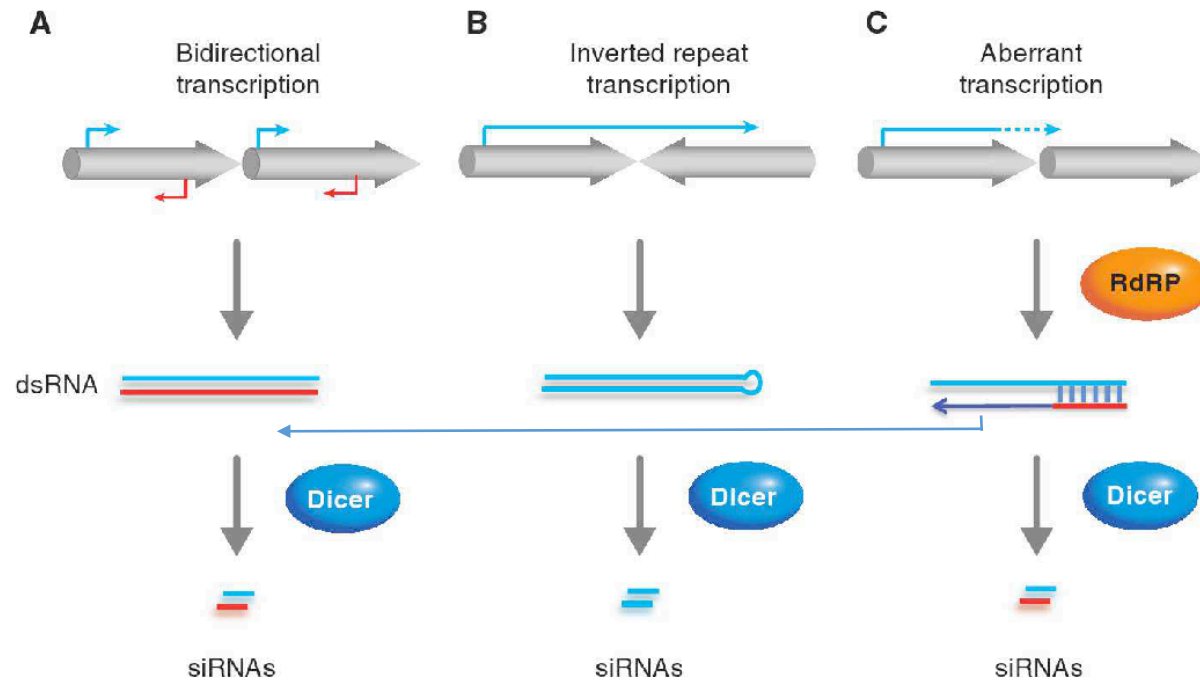

Figure 2. Pathways for the biogenesis of primary small RNAs that mediate silencing. (A) Bidirectional transcription has been observed at the *Schizosaccharomyces pombe* centromeric repeats and the *cenH* region of the silent mating-type locus and may provide a dsRNA substrate for the Dicer ribonuclease. (B) Transcription through inverted repeats found in many plant and animal cells can potentially produce dsRNA. (C) Transcription of aberrant RNAs that may lack proper processing signals may trigger dsRNA synthesis by RNA-dependent RNA polymerases (RdRPs). (D) Transcription from several driver loci gives rise to Piwi-associated small RNAs (piRNAs) that silence dispersed transposons. Piwi proteins together with other ribonucleases, which are not fully defined (represented by the gray dotted line), mediate primary piRNA generation.

RNAi silencing pathways

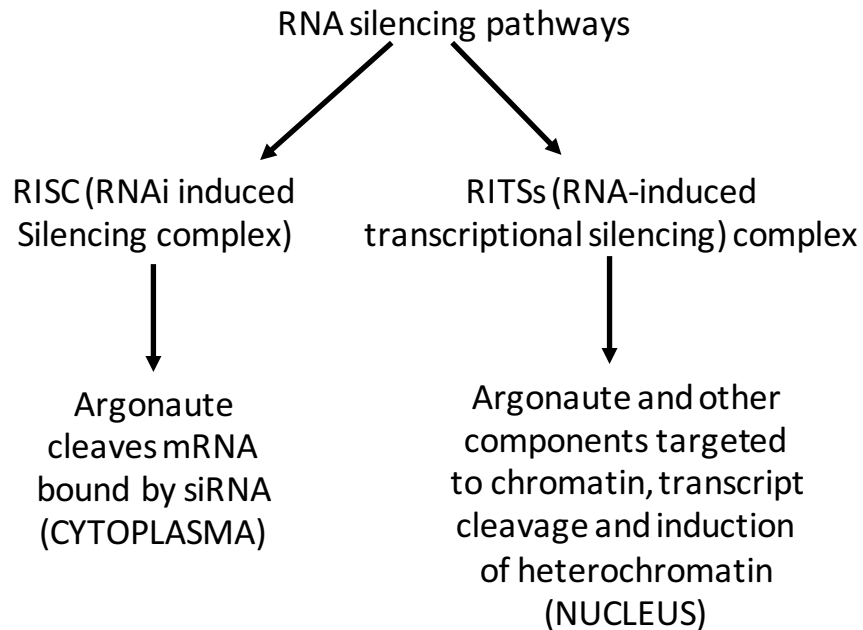

Table 1. Conservation of RNAi and heterochromatin proteins

<i>Schizosaccharomyces pombe</i>	<i>Arabidopsis thaliana</i>	<i>Caenorhabditis elegans</i>	<i>Drosophila</i>	<i>Homo sapiens</i>
Dcr1	DCL1 to 4	Dcr-1	Dcr1 and 2	Dcr-1
Ago1	AGO1 to 10	Rde-1, Alg-1, and -2	Ago1 to 3, Piwi	Ago1 to Ago4
–	–	Prg-1 and 2, and 19 others	Aubergine/Sting	Piwi1 to Piwi4
Chp1 ^a	CMT3	–	–	–
Tas3 ^b	–	AIN-1	GW182	TNRC6
Rdp1	RDR1 to 6	Ego-1, Rrf-1 to -3	–	–
Hrr1	SGS2/SDE3 ^c	ZK1067.2	GH20028p	KIAA1404
Cid12	–	Rde-3, Trf-4 ^c	CG11265 ^c	POLS ^c
Swi6	LHP1 (TFL2)	Hpl-1, F32E10.6 ^d	Hpl-2, HP1a, b	HP1α, β, γ
Clr4	SUVH2 to 6	–	Su(var)3-9	Suv39h1 and 2
Rik1 ^e	DDB1	M18.5	Ddb1	Ddb1
Cul4	CUL4	Cul4	Cul4	Cul4
Sir2	SIR2	Sir2-1	Sir2	SirT1
Clr3	–	–	–	–
Clr6	HDA6	Hda-1	Rpd3	HDAC1
–	DDM1	–	–	–
Eri1	ERI1	Eri-1	CG6393	THEX1

^aAn obvious ortholog of the chromodomain protein Chp1 has not been identified in the other model organisms listed here, but most eukaryotic cells contain multiple chromodomain proteins. CMT3 in *Arabidopsis* is a chromodomain DNA methyltransferase, which acts in the same pathway as AGO4 and may be analogous to Chp1.

^bTas3 is a GW motif protein. Members of this conserved family are found associated with Argonaute family members.

^cCid12 belongs to a large family of conserved proteins that share sequence similarity with the classical poly(A) polymerase as well as 2'-5'-oligoadenylate enzymes.

^d*C. elegans* have about 20 SET domain proteins, but a histone H3 lysine (K) 9 methyltransferase (KMT) specific for H3K9 has not yet been identified in this organism.

^e*Schizosaccharomyces pombe* contains another Rik1-like protein, Ddb1, which is involved in DNA damage repair. Metazoans and plants appear to contain only a single Rik1-like gene called Ddb1 involved in DNA damage repair; however, it is unknown whether it also participates in heterochromatin formation.

The RNAi machinery degrades RNAs derived from centromeres

Volpe et al. 2002 Science

Step1: *ura4⁻* strain

ura4⁻ renders cells resistant to 5-fluoroorotic acid (5-FOA)

Step2: insert a URA4 mini gene into chromosomal arm

(produces a short, non-functional URA4 RNA)

Step3: insert a URA4 full length gene into centromeric Positions (*cnt*, *imr*, *otr*)

(produces a full length, functional URA4 mRNA (=marker) when expressed)

→ In centromeric positions URA4 marker gene is silenced

→ =5FOA resistant

Step4: Elimination of RNAi components and HC components

or: random mutagenesis screen

Step5: Interesting yeast strains: 5FOA sensitive; Identify mutated genes

Clr4 High (*Suv39h1/2*)

Swi6 high (HP1)

S. pombe

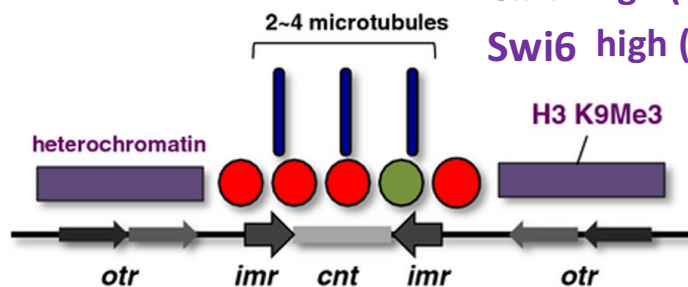

Components of the RNAi machinery in *S. pombe*:

1. **Dicer:** cleavage of dsRNA into siRNAs
2. **RISC/RITS with Argonaute (RNase domain):** target RNA cleavage guided by siRNA
3. **RNA dependent RNA polymerase: RdRP:** reverse transcription of RNA, guided by siRNA → creates dsRNA → RNAi amplification

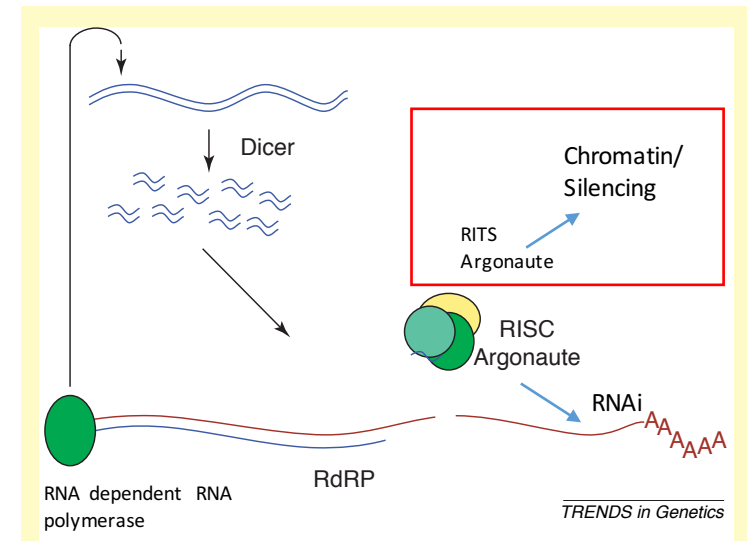

Figure 1. RNA interference. A simplified scheme illustrating how Dicer, Argonaute and RNA-dependent RNA polymerase (RdRP) participate in RNA silencing through RNA interference. Dicer processes dsRNA into 20–24 nt siRNA, which guides ‘slicing’ by Argonaute, via the RNA-induced silencing complex (RISC). Slicing and/or priming by siRNA could guide RdRP, which regenerates dsRNA, amplifying the cycle.

The RNAi machinery degrades RNAs derived from centromeres

Volpe et al. 2002 Science

Step1: *ura4⁻* strain

ura4⁻ renders cells resistant to 5-fluoroorotic acid (5-FOA)

Step2: insert a URA4 mini gene into chromosomal arm (produces a short, non-functional URA4 RNA)

Step3: insert a URA4 full length gene into centromeric Positions (*cnt*, *imr*, *otr*)

(produces a full length, functional URA4 mRNA (=marker) when expressed)

→ In centromeric positions URA4 marker gene is silenced

→ =5FOA resistant

Step4: Elimination of RNAi components and HC components

Or random mutagenesis screen

Step5: Interesting yeast strains: 5FOA sensitive; identify mutated gene(s)

Model system: 3 URA reporter genes:

1. URA4 reporter in centromere regions (*otr*, *imr*, *cnt*) → *ura4⁺*
2. URA4 minigene (shorter than centromeric URA4 located in a chromosomal arm (*ura4* DS/E)

Fig. 1. Centromeric silencing is relieved in *ago1⁻*, *dcr1⁻*, and *rdp1⁻* mutant strains compared to wild type. Diagram of the three *S. pombe* centromeres (A) including locations of *ura4⁺* transgenes as well as outermost (*otr*), innermost (*imr*), and central (*cnt*) centromeric regions (24, 25). Conserved *dg* (green) and *dh* (red) repeats are indicated as arrows. Regions containing one or more tRNA genes are indicated by yellow boxes. Northern analysis (B) of RNA transcripts transcribed from centromeric *ura4⁺* transgenes and a *ura4⁺* (DS/E) mini-gene located on the chromosome arm. Transcripts derived from centromeric repeats were detected by Northern blotting (C and D) using probes specific for *dg* centromeric repeats (Fig. 5).

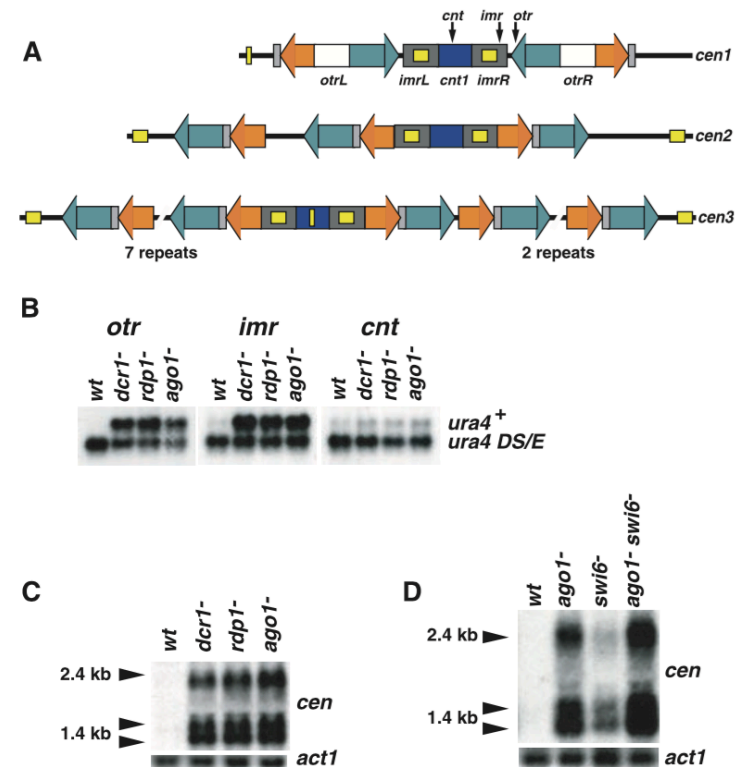

B: loss of RNAi machinery results in increases URA4 reporter expression

C: loss of RNAi machinery results in increased centromeric transcript levels

D: loss of RNAi and loss of Swi6 results in increase centromeric transcript levels

The RNAi machinery degrades RNAs derived from centromeres

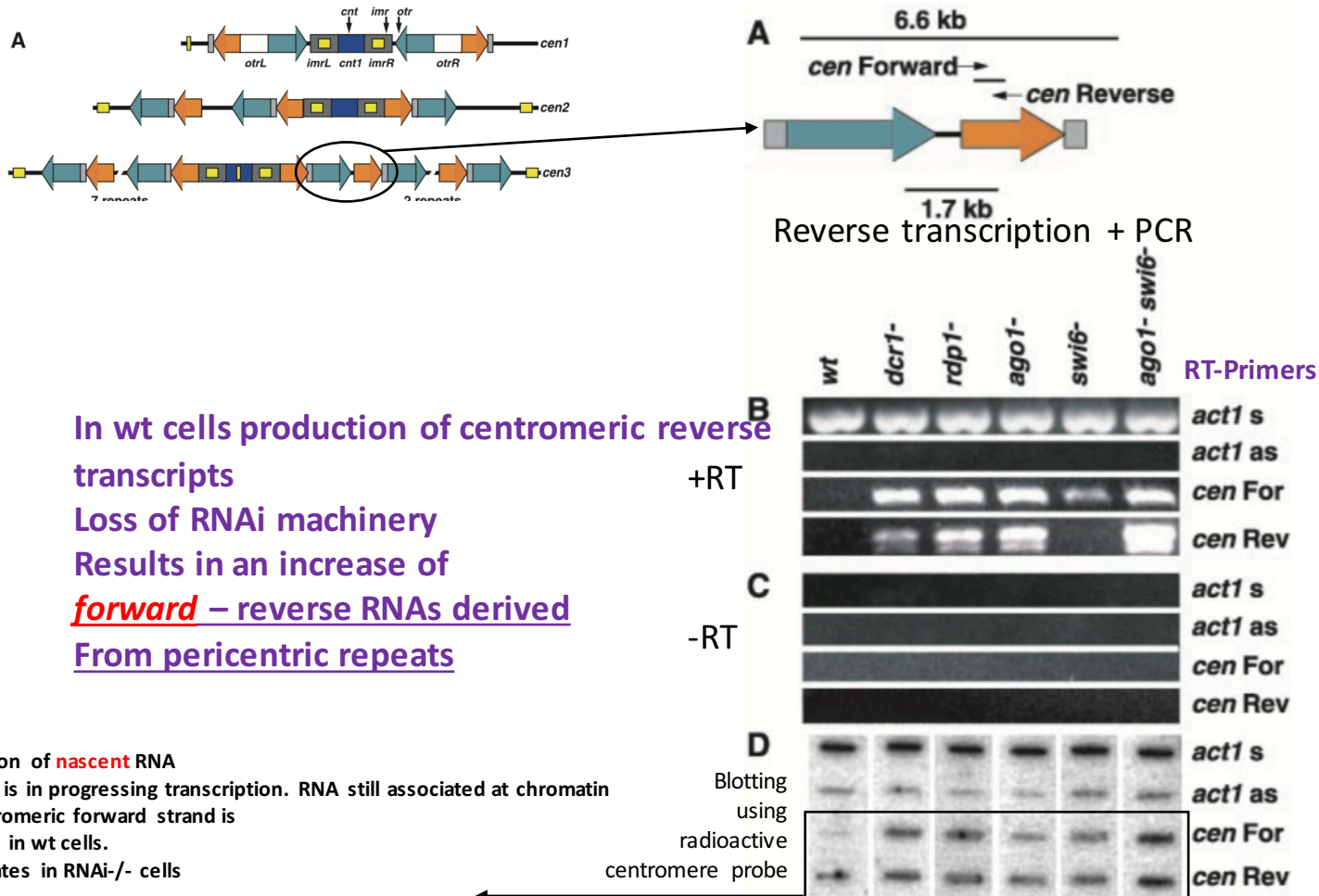

Fig. 2. Centromeric *otr* transcripts are both transcriptionally and posttranscriptionally regulated. (A) A schematic diagram showing the direction of transcription of forward and reverse transcripts corresponding to the *dh* repeat. Strand-specific RT-PCR analysis was performed in the presence (B) or absence (C) of reverse transcriptase. Samples were incubated with primers from the *dh* repeat complementary to either the forward (*cen For*) or reverse (*cen Rev*) centromeric transcripts in first strand cDNA synthesis reaction (primer locations are summarized in Fig. 5). Both primers were present in subsequent cycles of PCR amplification after heat inactivation of the reverse transcriptase. Treatment of control reactions lacking reverse transcriptase (C) was identical except that these samples were not subjected to first strand synthesis. Strand-specific control reactions were also conducted using primers specific for *act1* sense (*act1 s*) or *act1* antisense (*act1 as*) transcripts. Strand-specific analysis of nascent RNA transcripts was performed by nuclear run-on assay (D). Radiolabeled nascent RNA purified from mutant and wild-type strains was hybridized to nylon membranes containing strand-specific probes made using the same primer pair as in (A). These probes recognized either forward (*cen For*) or reverse (*cen Rev*) centromeric transcripts. Control probes recognized either sense (*act1 s*) or antisense (*act1 as*) actin transcripts.

In wt cells production of centromeric reverse transcripts
 Loss of RNAi machinery
 Results in an increase of
forward – reverse RNAs derived
From pericentric repeats

Preparation of nascent RNA
 RNA that is in progressing transcription. RNA still associated at chromatin
 The centromeric forward strand is degraded in wt cells.
 Accumulates in RNAi-/- cells

Loss of the RNAi machinery results in the loss of H3K9me3 at outermost repeats

Fig. 3. Chromatin structure at centromeric repeats is altered in *ago1⁻*, *dcr1⁻*, and *rdp1⁻* mutants. Chromatin immunoprecipitation (ChIP) was performed on extracts from formaldehyde fixed mutant or wild-type cells. DNA fragments purified from whole-cell extracts (wce) or co-precipitated with antibodies to K4 or K9 histone H3 were amplified by PCR using primers specific for centromeric *dg* repeats (Fig. 5) or *act1* (A). Quantitation was performed using quantitative PCR (B) and normalized to actin (K4) and mating type region (K9) controls, which were amplified

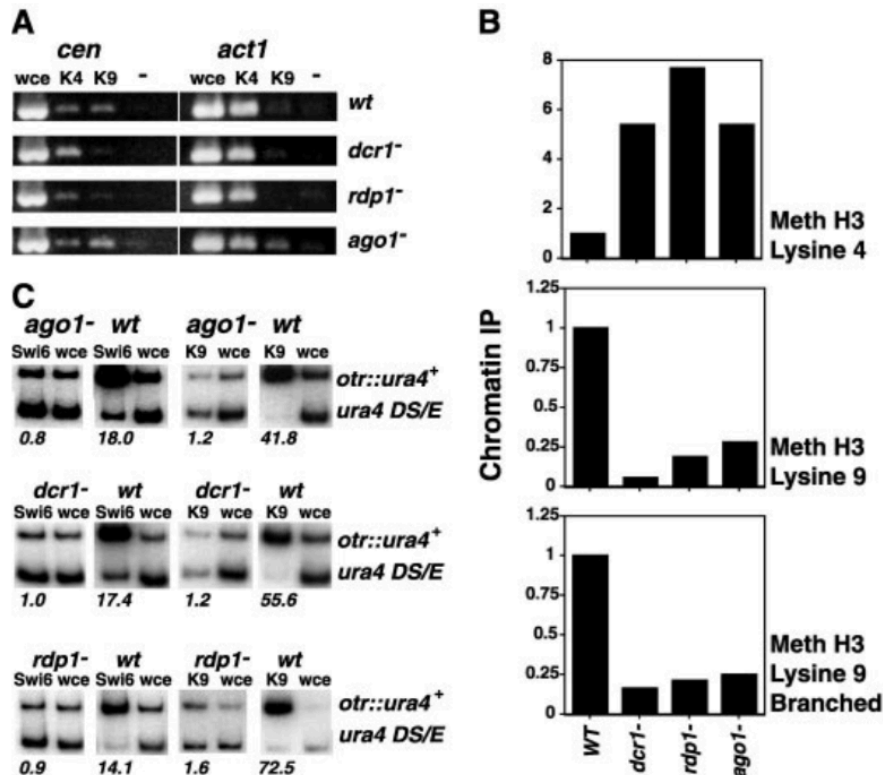

from the same ChIPs in each genotype (21). DNA fragments from wce or co-precipitated with antibodies to Swi6 or K9 histone H3 were amplified by multiplex PCR using *ura4*-specific primers (C). These primers amplify both a *ura4⁺* transgene located in the *otr* of *cen1* (*otr::ura4⁺*) and the *ura4 DS/E* minigene (*ura4 DS/E*) located on the chromosome arm. Relative levels were estimated using a FUJI phosphorimager and are indicated below each lane.

Loss of the RNAi machinery results in the loss of H3K9me3 at outermost repeats

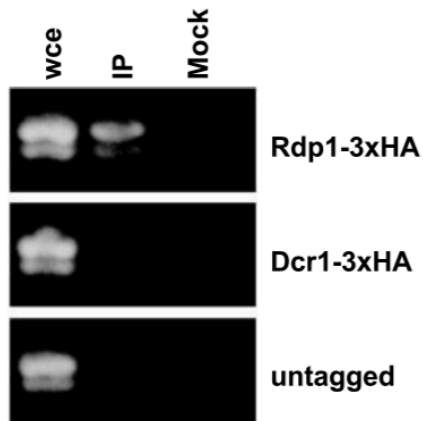
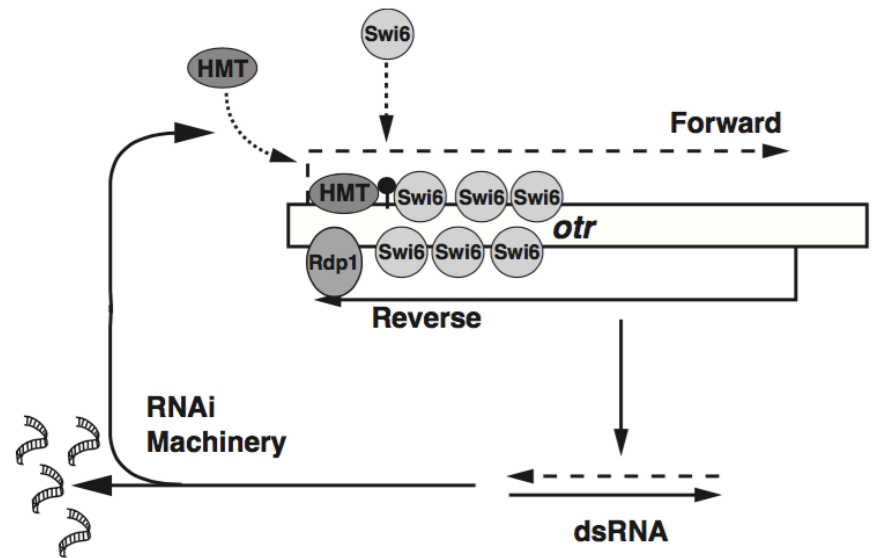

Fig. 4. Rdp1, but not Dcr1, is bound to centromeric chromatin. Chromatin immunoprecipitation (ChIP) was performed on extracts derived from triple-HA tagged Dcr1 or Rdp1 strains. DNA fragments from wce or co-precipitated with antibodies raised against the triple-HA tag were amplified by PCR using centromere-specific primers and compared to untagged strains. Mock reactions were identical except without the addition of primary antibody.

Fig. 6. The RNAi machinery is required for the initiation and maintenance of the heterochromatic state of centromeric repeats. Reverse strand centromeric transcription occurs in wild-type cells and is degraded posttranscriptionally by the RNAi machinery. Low-level transcription from the forward strand and/or amplification by Rdp1 results in generation of dsRNA, which is converted to siRNA by RNAi. Rdp1, bound to the chromatin, promotes targeting of histone modifications to specific sequences via siRNA, resulting in maintenance of the heterochromatic state (HMT, histone methyl transferase).



4 critical steps in heterochromatin formation at centromeres in *S. pombe*

1. Pericentric sense anti-sense transcription

2. RNAi mediated degradation of pericentromeric dsRNA

3. Amplification of siRNA loop by RNA dependent RNA polymerase

4. Heterochromatinization

Table 1. Conservation of RNAi and heterochromatin proteins

<i>Schizosaccharomyces pombe</i>	<i>Arabidopsis thaliana</i>	<i>Caenorhabditis elegans</i>	<i>Drosophila</i>	<i>Homo sapiens</i>
Dcr1	DCL1 to 4	Dcr-1	Dcr1 and 2	Dcr-1
Ago1	AGO1 to 10	Rde-1, Alg-1, and -2	Ago1 to 3, Piwi	Ago1 to Ago4
–	–	Prg-1 and 2, and 19 others	Aubergine/ Sting	Piwi1 to Piwi4
Chp1 ^a	CMT3	–	–	–
Tas3 ^b	–	AIN-1	GW182	TNRC6
Rdp1	RDR1 to 6	Ego-1, Rrf-1 to -3	–	–
Hrr1	SGS2/SDE3 ^c	ZK1067.2	GH20028p	KIAA1404
Cid12	–	Rde-3, Trf-4 ^c	CG11265 ^c	POLS ^c
Swi6	LHP1 (TFL2)	Hpl-1, F32E10.6 ^d	Hpl-2, HP1a, b	HP1 α , β , γ
Clr4	SUVH2 to 6	–	Su(var)3-9	Suv39h1 and 2
Rik1 ^e	DDB1	M18.5	Ddb1	Ddb1
Cul4	CUL4	Cul4	Cul4	Cul4
Sir2	SIR2	Sir2-1	Sir2	SirT1
Clr3	–	–	–	–
Clr6	HDA6	Hda-1	Rpd3	HDAC1
–	DDM1	–	–	–
Eri1	ERI1	Eri-1	CG6393	THEX1

^aAn obvious ortholog of the chromodomain protein Chp1 has not been identified in the other model organisms listed here, but most eukaryotic cells contain multiple chromodomain proteins. CMT3 in *Arabidopsis* is a chromodomain DNA methyltransferase, which acts in the same pathway as AGO4 and may be analogous to Chp1.

^bTas3 is a GW motif protein. Members of this conserved family are found associated with Argonaute family members.

^cCid12 belongs to a large family of conserved proteins that share sequence similarity with the classical poly(A) polymerase as well as 2'-5'-oligoadenylate enzymes.

^d*C. elegans* have about 20 SET domain proteins, but a histone H3 lysine (K) 9 methyltransferase (KMT) specific for H3K9 has not yet been identified in this organism.

^e*Schizosaccharomyces pombe* contains another Rik1-like protein, Ddb1, which is involved in DNA damage repair. Metazoans and plants appear to contain only a single Rik1-like gene called Ddb1 involved in DNA damage repair; however, it is unknown whether it also participates in heterochromatin formation.

Step 2: RNAi – dsRNA formation – RITS assembly

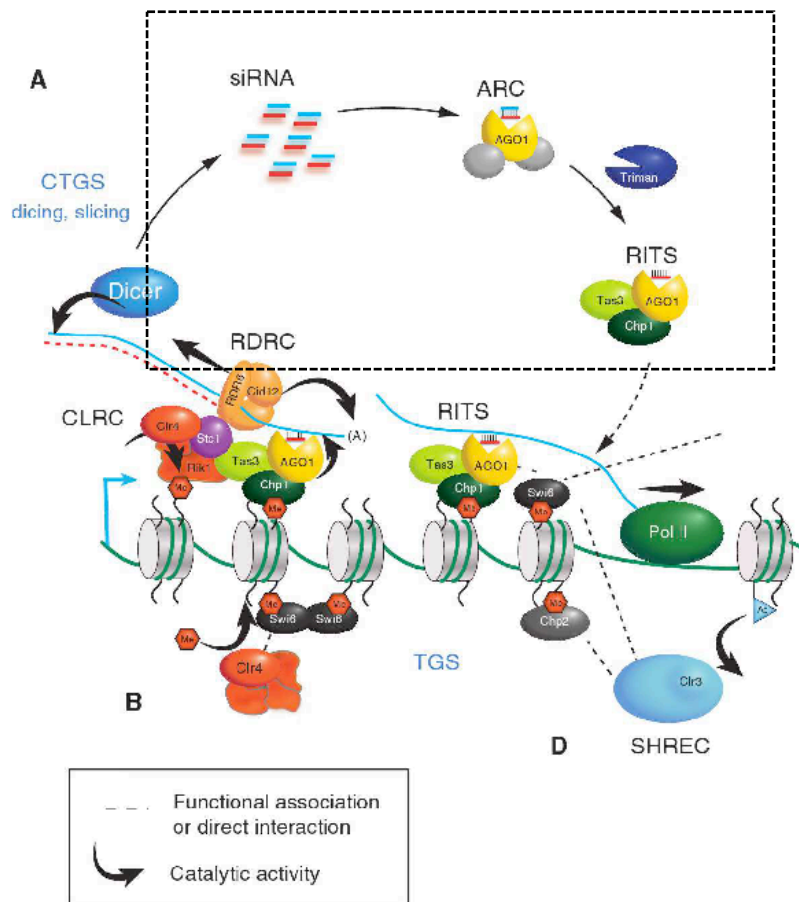

0. sense-antisense transcription produces dsRNA that is degraded by

1. Dicer processed pericentric dsRNAs generating siRNAs (nucleus)
2. siRNA incorporated into the RITS complex consisting of Ago1, Chp1 and Tas3
3. RITS used siRNA to target nascent transcripts from centromeres (base pairing) and induced heterochromatin formation
4. Chp1 contains a chromodomain that binds to H3K9me3 that was previously imposed by Clr4
5. Clr4 has a chromodomain that binds H3K9me3 and Clr4 interacts with RITS
6. H3K9me3 and recruitment of Swi6 that stabilizes the RITS complex
7. Chp2 chromodomain protein binds H3K9me3 and recruits the SHREC HDAC complex (H4K14 specific Clr3 HDAC) that shuts down transcription in S-Phase

Step 3: RNA dependent RNA Pol activity

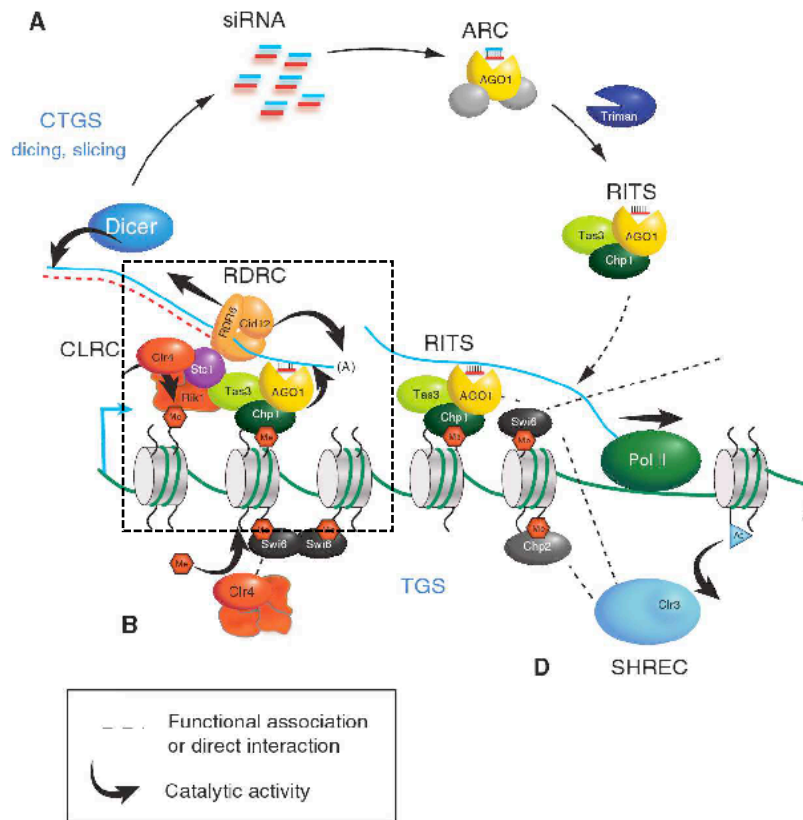

1. Swi6 interacts with Ers1 that binds to the RDRD (RNA directed RNA polymerase complex); HP1 has affinity for RNA
2. RDRD contains Rdp1 and other components.
3. Rdp1 does not require a primer for dsRNA synthesis. siRNA/RITS gives information for specific interaction of Rdp1 complex with template.
4. RDRD interacts with chromatin at centromere in a siRNA and Clr4 dependent manner → siRNAs and Clr4 target RDRD to peri-centromeres

Step 4: Heterochromatinization (Clr4, Swi6)

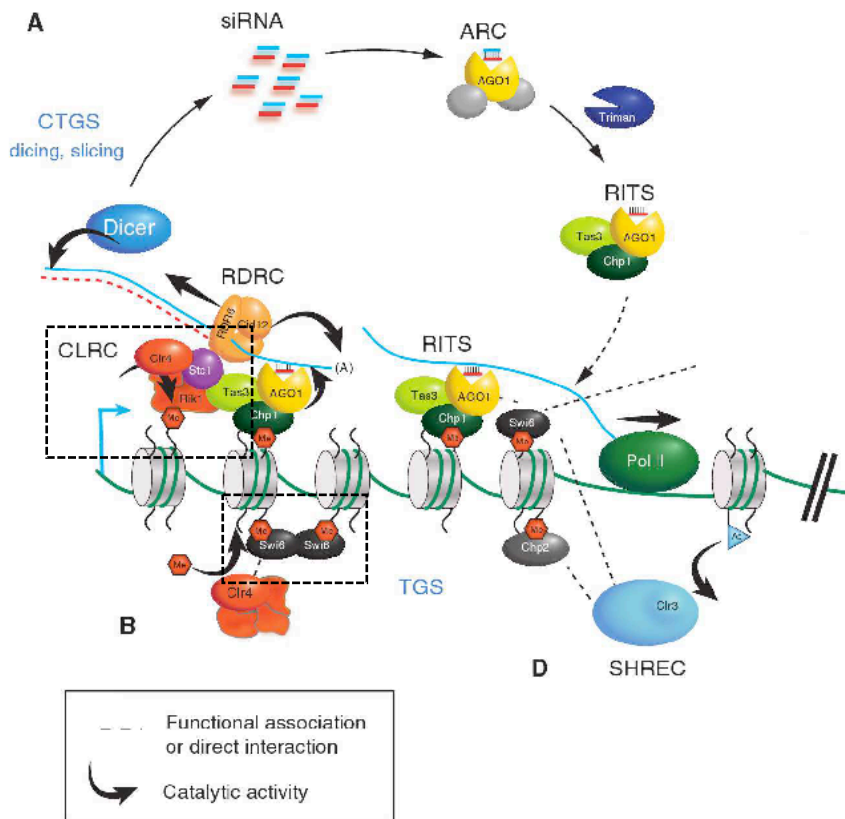

1. Clr4 is required for stabilizing RITS at centromere. → some Clr4-H3K9me3 is required to start heterochromatin formation. Note: loss of RNAi leads to loss of centromeric silencing → RNAi is required to boost H3K9me3/Swi6
2. Clr4 is a component of the CLRC complex
3. CLRC and RITS interact with each other via Stc1. Note: in RNAi^{-/-} cells Stc1 levels are reduced → siRNAs contribute to complex structure that favors the action of Stc1 in ensuring the interaction between RITS and CLRC (ev. via other factors)
4. Efficient H3K9me3 by Clr4; Swi6 is recruited

Step 4: Heterochromatinization (Clr4, Swi6)

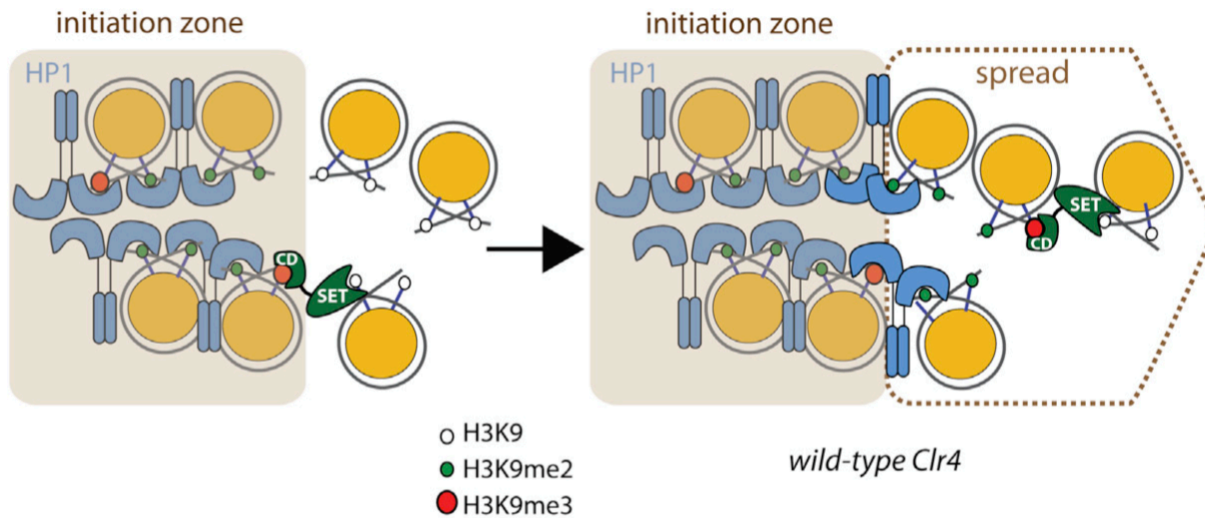

Clr4 mediates H3K9m3; Clr4 has a chromo-domain that interacts with H3K9me2/3
Swi6 interacts with H3K9me2/3 and forms homodimer with another Swi6; Clr4 bind H3K9me2 + interacts with Swi6.
Spreading of Clr4/Swi6 along chromatin
Swi6 mediates nucleosome bridging and shortening of nucleosome to nucleosome distance → efficient chromatin compaction

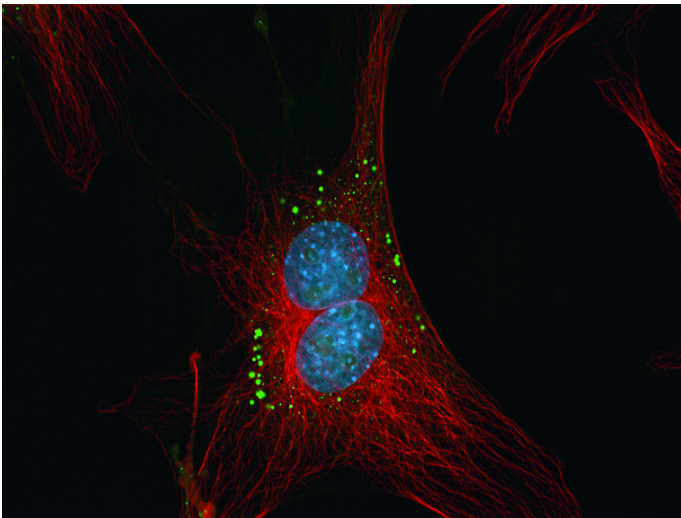

MECHANISM CONSERVED FROM *S.pombe* → humans

Clr4	Suv39h1/h2
Swi6	HP1
H3K9me3	H3K9me3

The role of RNA polymerase in centromeric silencing

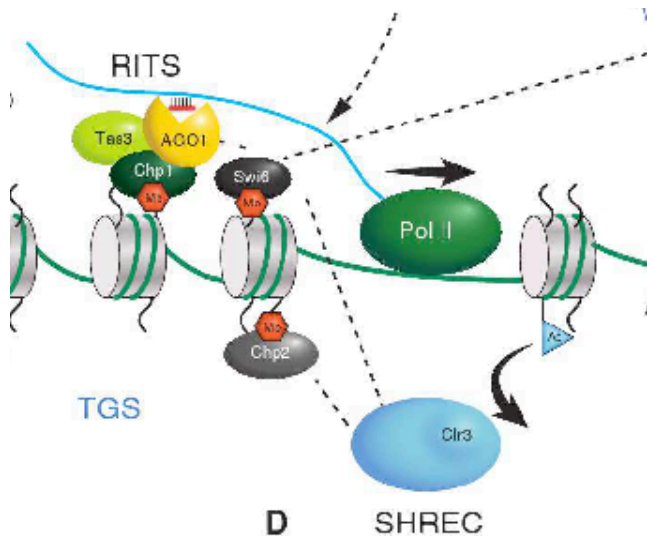

Transcription by RNA-polymerase is essential for heterochromatin formation

Evidence: Mutations in RNA-Pol in *S.pombe*:

Rpb7-1: Reduced levels of transcription at pericentric repeats → less siRNAs → loss of silent chromatin

Rpb2-m203: RNA is produced, but not processed into siRNAs → reduced heterochromatin

- RNA polymerase is not exclusively responsible for transcription, but also has a role in integrating transcription with the downstream processing of the produced RNA
- Remember the RNA-Pol holoenzyme is a huge complex that integrates many proteins: i.e. FACT: chromatin modelling factor that colocalizes to centromeres i.e. Spt6: RNA pol interactor that is required to establish H3K9me3
- precise mechanisms: unknown – the complexity of protein interaction with the RNA-Pol holoenzyme is extremely high

The maintenance of heterochromatin through numerous cell cycles

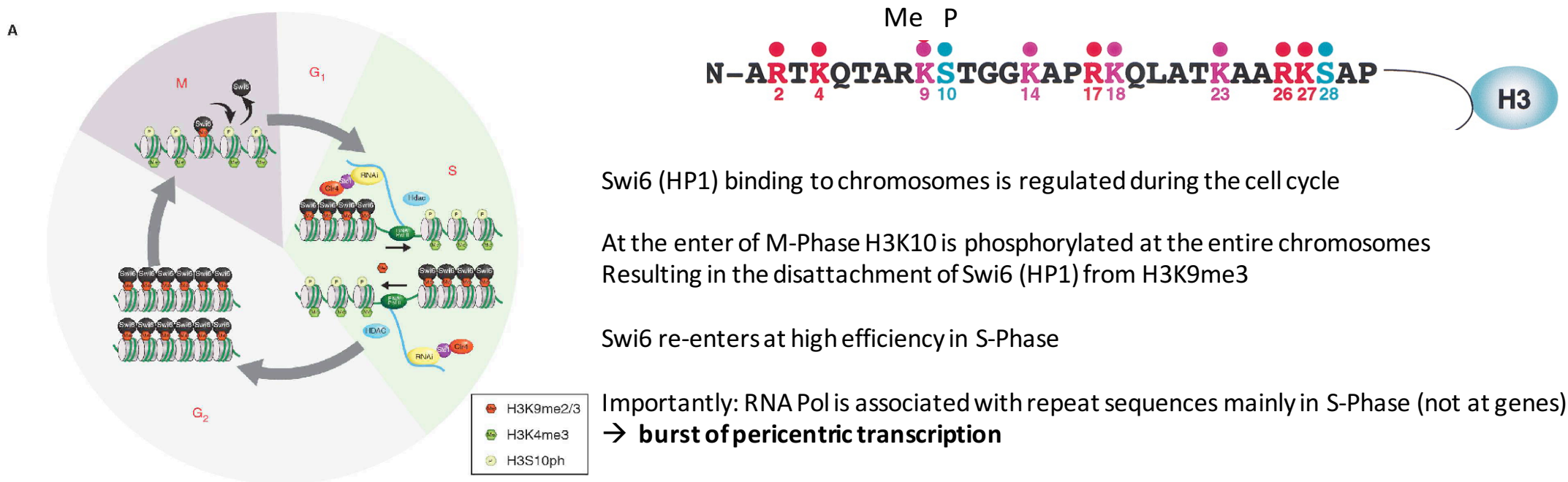

Figure 4. Cell-cycle regulation of centromere heterochromatin assembly. (A) Heterochromatin located at chromosomal centromeres becomes differentially methylated and phosphorylated on histones throughout the cell cycle as indicated. These modifications control the binding of the heterochromatin protein Swi6. During mitosis Swi6 is displaced by H3S10 phosphorylation. Swi6 binding is reestablished during subsequent DNA replication (S phase) when a more accessible chromatin structure permits RNA Pol II to transcribe centromeric DNA. This, in turn, recruits the RNAi machinery to direct H3K9me methylation. (B) Replication-coupled RNAi model (Li et al. 2011). This figure

Swi6 (HP1) binding to chromosomes is regulated during the cell cycle

At the enter of M-Phase H3K10 is phosphorylated at the entire chromosomes
Resulting in the disattachment of Swi6 (HP1) from H3K9me3

Swi6 re-enters at high efficiency in S-Phase

Importantly: RNA Pol is associated with repeat sequences mainly in S-Phase (not at genes)
→ **burst of pericentric transcription**

→ Rapid recruitment of the RNAi-machinery by nascent transcripts

→ Burst in heterochromatin formation!!!

→ G₂: reduced transcription → heterochromatin already formed

Note: Stc1 interacts with RITS (Ago1) and the CLRC complex (Clr4)

Note: SHREC complex contains the HDAC Clr3 that is important to subsequently shut down transcription

The maintenance of heterochromatin

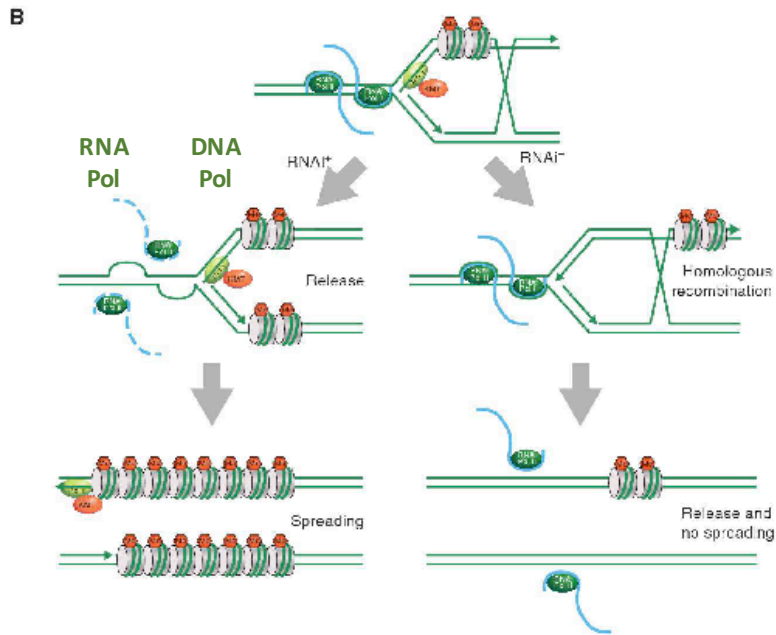

H3K9me methylation. (B) Replication-coupled RNAi model (Li et al. 2011). This figure illustrates an alternative model for how RNAi works at centromeres. Here, RNAi serves to release RNA Pol II from chromatin to avoid collision with DNA replication machinery during S phase. See text for further details. (A, Adapted from Djupedal and Ekwall 2008.)

RNAi serves to release RNA polymerase from chromatin



Swi6 (HP1) binding to chromosomes is regulated during the cell cycle

NOTE: RNA Polymerase can encounter DNA Polymerase → collision of major protein complexes that are linked to open DNA double strands (fragile DNA) → sterical stress on DNA → risk of breakage → genomic instability

RNAi mutants result in stalling DNA replication forks and activate recombination

Pol epsilon recruits CLRC complex (Clr4) – H3K9me3 → recruitment of RNAi machinery

RNA dependent RNA polymerase → amplification of RNAi pathway

→ Heterochromatin formation (SHREC and CLRC complex)

→ Silencing of transcription

HOW IS CHROMATIN SPREADING LIMITED

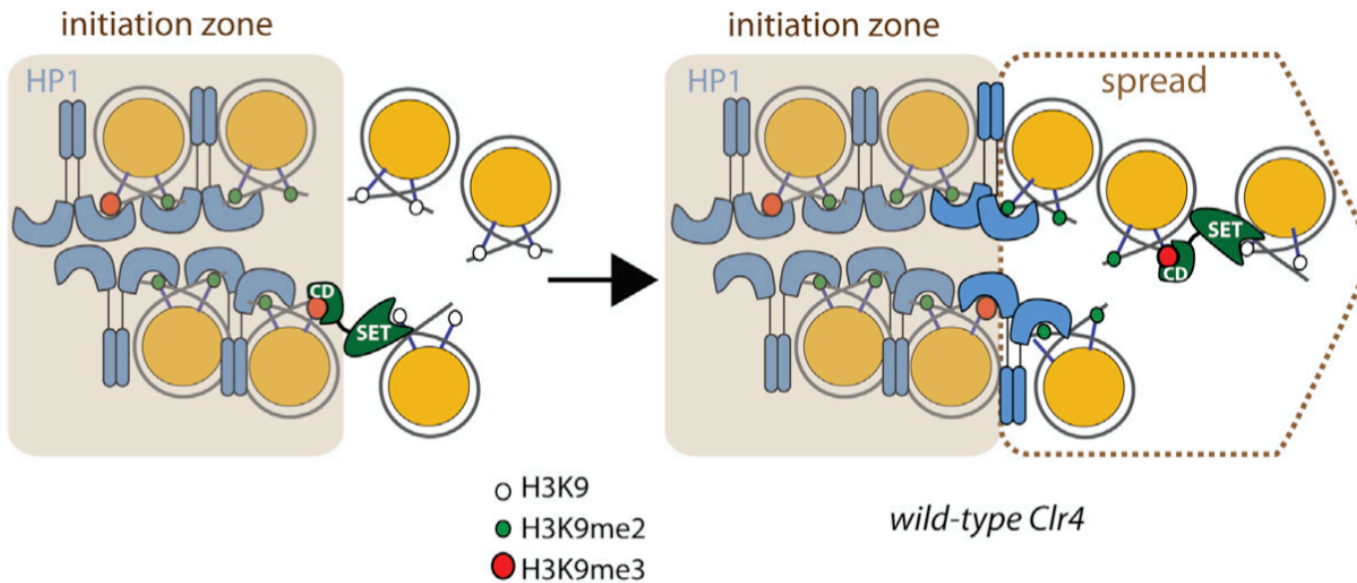

1. Clr4 mediates H3K9me3; Clr4 has a chromodomain that interacts with H3K9me3
2. Swi6 interacts with H3K9me3 and forms homodimer with another Swi6
3. Swi6 directly interacts with Clr4
4. These interactions mediate the spreading of Clr4/Swi6/H3K9me3 along chromatin.

Swi6 mediates nucleosome bridging and shortening of nucleosome to nucleosome distance
 → Chromatin compaction and SPREADING

HOW CAN THIS PROCESS BEING STOPPED????

HOW IS CHROMATIN SPREADING LIMITED

Boundary regions separate genome segments with different chromatin structure (euchromatin/heterochromatin)

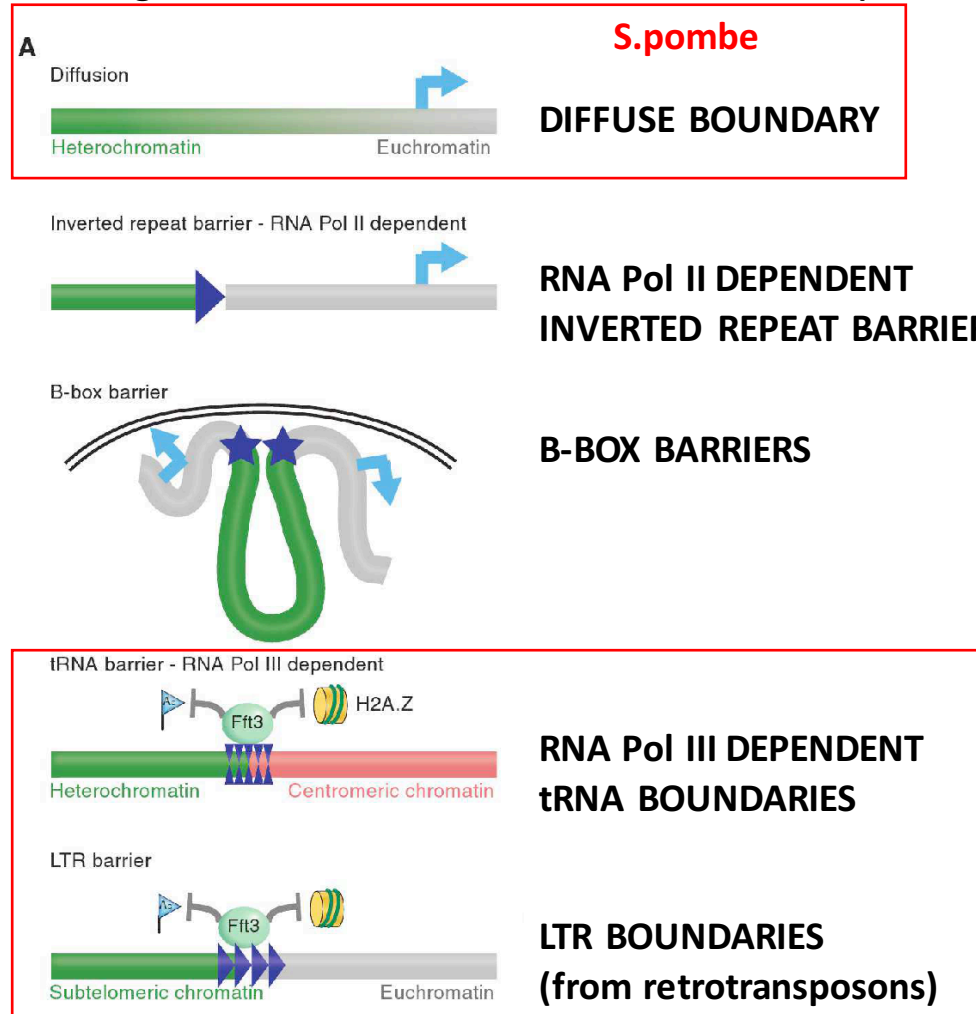
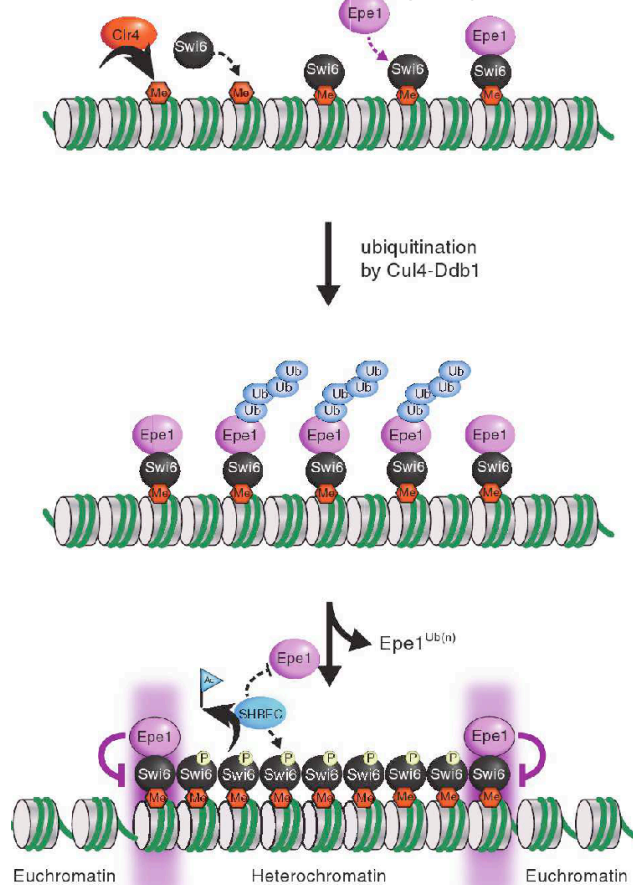

Figure 5. Chromatin boundaries and the boundary mechanism involving Epe1 (for enhancement of position effect) in *S. pombe*. (A) A schematic representation of different types of boundary elements in *S. pombe*. (B) The mechanism of boundary function by

HOW IS CHROMATIN SPREADING LIMITED: Epe1

3

Diffuse boundary: Epe1



Epe 1 is an “anti-silencing” factor = counteracts heterochromatin building.

S. pombe Epe1^{-/-} : more heterochromatin spreading

1. Epe1 forms a complex with Swi6 in heterochromatic regions
2. However: **Epe1 is ubiquitinated and degraded by a cullin dependent ubiquitinase in regions with heterochromatin and remains only at boundaries between heterochromatin and euchromatin**
(not known how ubiquitination is prevented at boundaries)
3. After removal of Epe1, Swi6 becomes phosphorylated (casein kinase 2)
4. Swi6 phosphorylation causes the recruitment of the SHREC complex → heterochromatin spreading and reduced Eps1 levels

types of boundary elements in *S. pombe*. (B) The mechanism of boundary function by Epe1. Epe1 associates with Swi6, however, when the antisilencing factor is ubiquitinated by the Cul4-Ddb1 ligase and degraded in the heterochromatin region to allow for heterochromatin assembly. However, at boundaries, Epe1 is somehow protected from degradation, thus restricting the spreading of heterochromatin. Phosphorylation of Swi6 contributes to the dissociation of Epe1 at heterochromatin, while promoting the association with the HDAC complex SHREC in maintaining histone hypoacetylation. (A, Adapted from [Scott et al. 2007.](#))

HOW IS CHROMATIN SPREADING LIMITED: tRNA clusters and Fft3

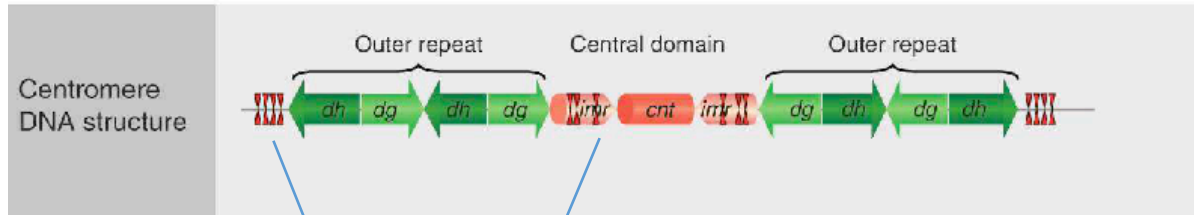

A factor that prevents the spreading of euchromatin into heterochromatin

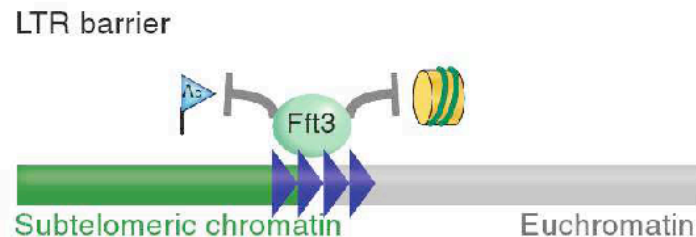
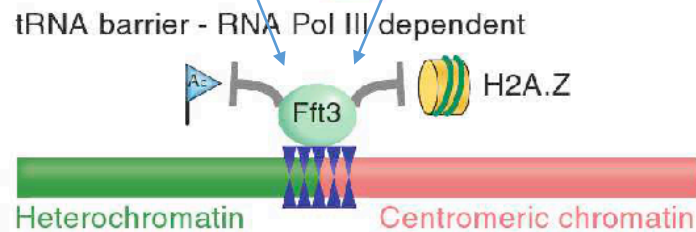

1. Outer repeats are flanked by tRNA gene clusters, depleted for nucleosomes ("nucleosome evicted" region)
2. tRNA genes are actively transcribed by RNA Pol III = EUCHROMATIN
3. Centromeric repeats represent HETEROCHROMATIN
4. Fft3 is restricted to tRNA genes (mechanism not known)
5. Fft3 is chromatin remodeling factor with ATP dependent helicase activity. Recognizes acetylated histones and remodels nucleosomes to a more open conformation (see nucleosome remodeling)
6. Loss of Fft3 → extension of euchromatin into centromeric regions (H3/H4 acetylation and H2AZ = histone variant in euchromatin)
7. Mechanism ???, also works at other sites → LTR barriers at subtelomeres

H2A.Z: excluded from centromere; However, in some of the other studies (Nat. Genet. 41, 941–945 and Genes Dev., 21, 1519–1529) have shown that incorporation of H2A.Z in nucleosomes, when it co-occurs with H3.3, makes them weaker. Positioning of H2A.Z containing nucleosomes around transcription start sites has now been shown to affect the downstream gene expression.

HOW IS CHROMATIN SPREADING LIMITED: tRNA clusters and Fft3

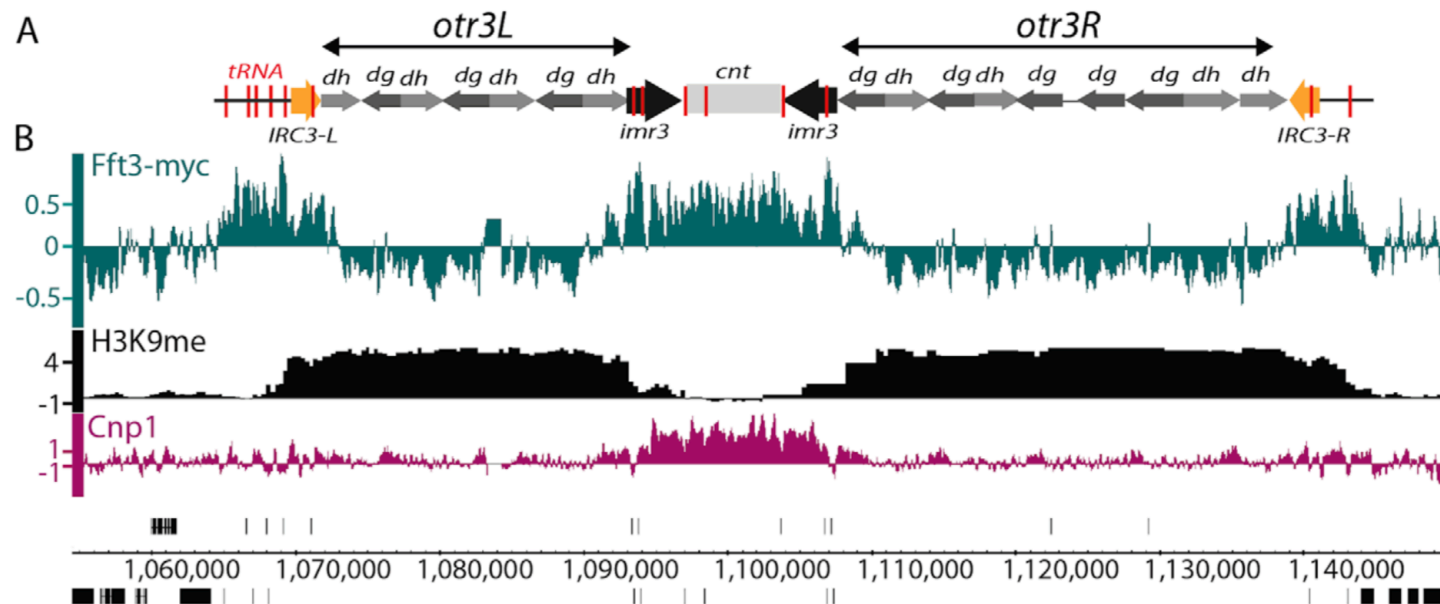
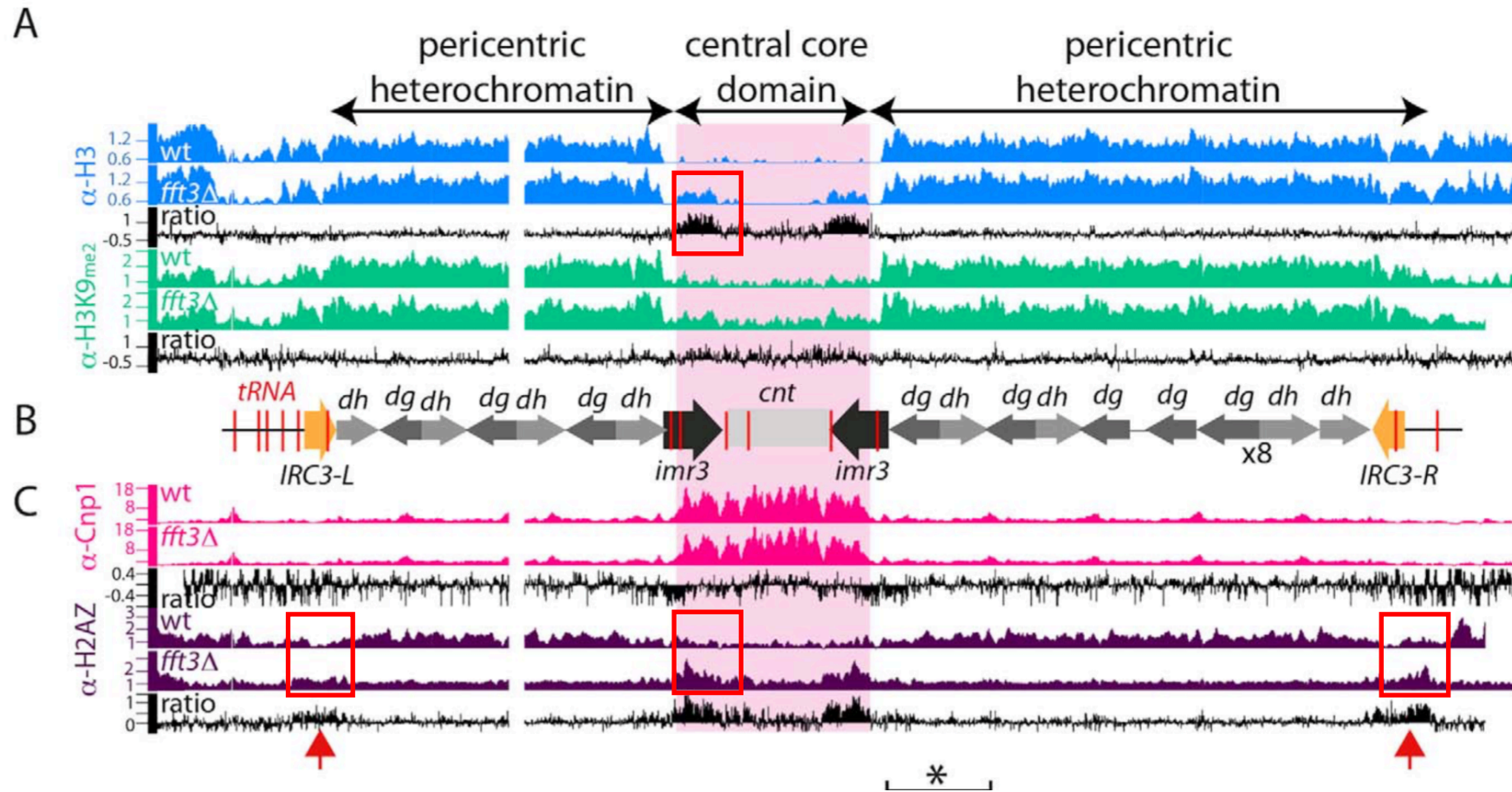

Figure 2. Fft3 associates with known centromeric insulators and the central core domain. A) A schematic presentation of centromere 3. tRNA genes are marked in red and the *IRC* elements in yellow. B) A genome browser view of *cen3* showing the ChIP-chip occupancy profile for Fft3-myc (green), H3K9me2 (black) and Cnp1 (purple). Data on the Y-axis are presented in log₂ scale and the X-axis shows genome positions in base pairs. H3K9me2 data are from [1].

doi:10.1371/journal.pgen.1001334.g002

HOW IS CHROMATIN SPREADING LIMITED: tRNA clusters and Fft3



Normally H2A.Z is absent from all centromeric regions, including both the Cnp1 containing inner domain and the pericentric heterochromatin. H2A.Z marks active genes. Surprisingly, absence of Fft3, the H2A.Z levels increase by 4-fold at *imr3* and increase in IRC-L

HOW IS CHROMATIN SPREADING LIMITED: tRNA clusters and Fft3

D

CHIP on
Imr – region

Loss of Ffts3 results in
An extension of euchromatin
to imr repeats
(H2A-Z, H4K12Ac, H3K9Ac)

Ffts has a chromatin
boundary function

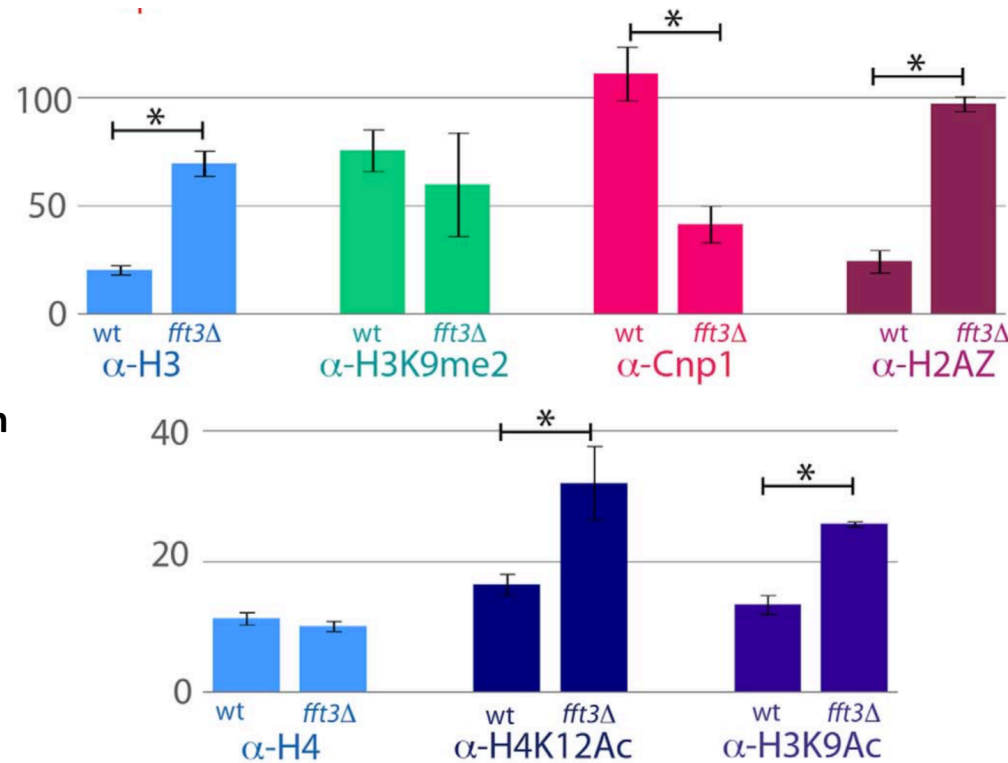
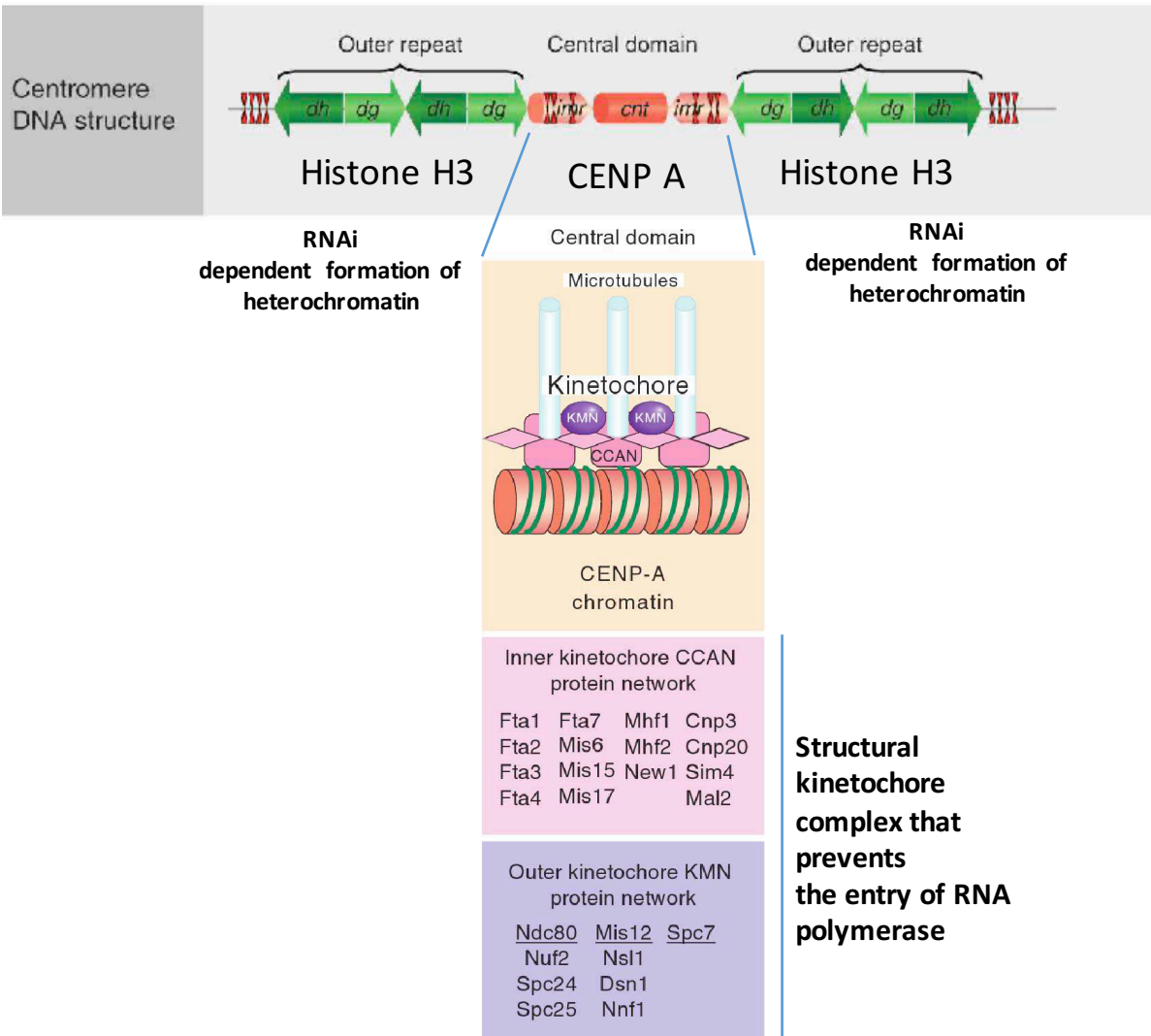

Figure 3. Centromeric boundary function is impaired in *fft3Δ* cells. A) The CHIP-chip distributions of histone H3 (blue) and H3K9me2 (green) at centromere 3 in wt and *fft3Δ* cells are shown in Genome Browser images. Y-axis: Linear scale. Mutant/wt ratios are indicated in black in log2 scale. B) A schematic diagram of centromere 3. tRNA genes are marked in red and the *IRC* elements in yellow. C) Genome browser images showing CHIP-chip data for Cnp1 (red) and H2A.Z^{Phit1} (purple). Y-axis: Linear scale. Mutant/wt ratios are shown in black in log2 scale. D) Bar diagrams showing the results from real-time quantitative PCR analysis of CHIP signals. The enrichments at *imr3* are relative to the *act1+* euchromatic control locus except for the Cnp1 enrichment which is relative to *cen1*. The CHIP signals were normalized to input samples from the same chromatin extract. The error bars represent S.D. values from triplicate samples. *indicates a significant difference between wt and mutant ($P < 0.01$; T-test, two-tailed, unpaired). doi:10.1371/journal.pgen.1001334.g003

WHY IS CENTROMERIC HETEROCHROMATIN IMPORTANT?



At the central domain the majority of histone H3 is exchanged for Cnp1 = CENP A
 → ca 19-24 CENP A nucleosomes per centromere

The CENPA gene encodes a centromere protein which contains a histone H3 related histone fold domain that is required for targeting to the centromere. CENPA is proposed to be a component of a modified nucleosome or nucleosome-like structure in which it replaces 1 or both copies of conventional histone H3 in the (H3-H4)₂ tetrameric core of the nucleosome particle. Silencing in central domain is thought to be mediated by the altered nucleosome composition and kinetochore construction (sterical hindrance)

Recruitment of CENP A requires RNAi and the presence of heterochromatin

WHY IS CENTROMERIC HETEROCHROMATIN IMPORTANT?

- Plasmid with only central repeats cannot be maintained in *S. pombe*
- No CENP-A incorporation
- Addition of outer repeat + central repeats: CENP A incorporation and plasmid maintenance
- Heterochromatin at outer repeats stabilize centromere function.

HETEROCHROMATIN IS IMPORTANT TO ACTIVATE CENTROMERE FUNCTION

A

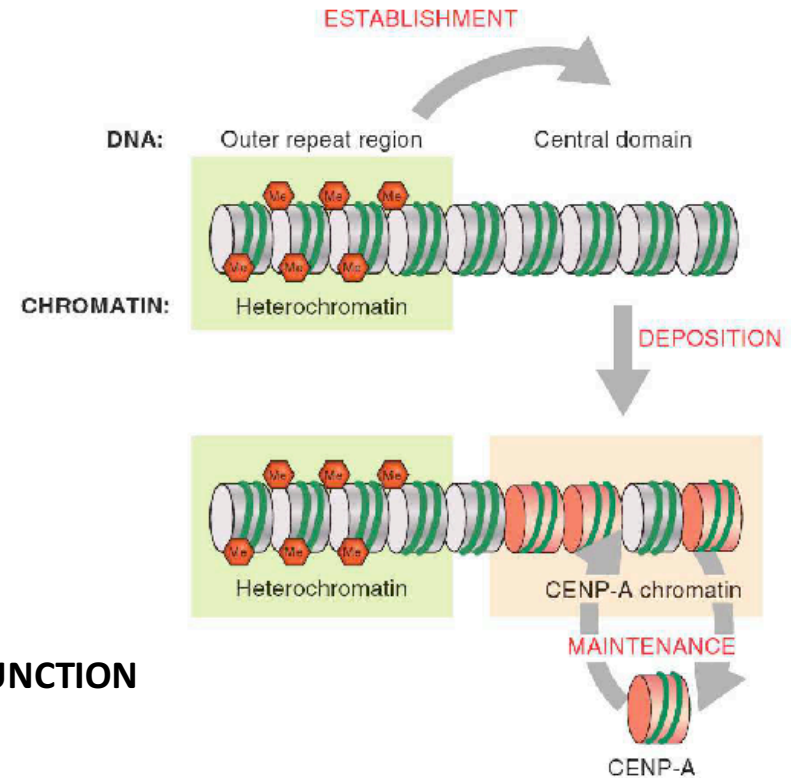

WHY IS CENTROMERIC HETEROCHROMATIN IMPORTANT?

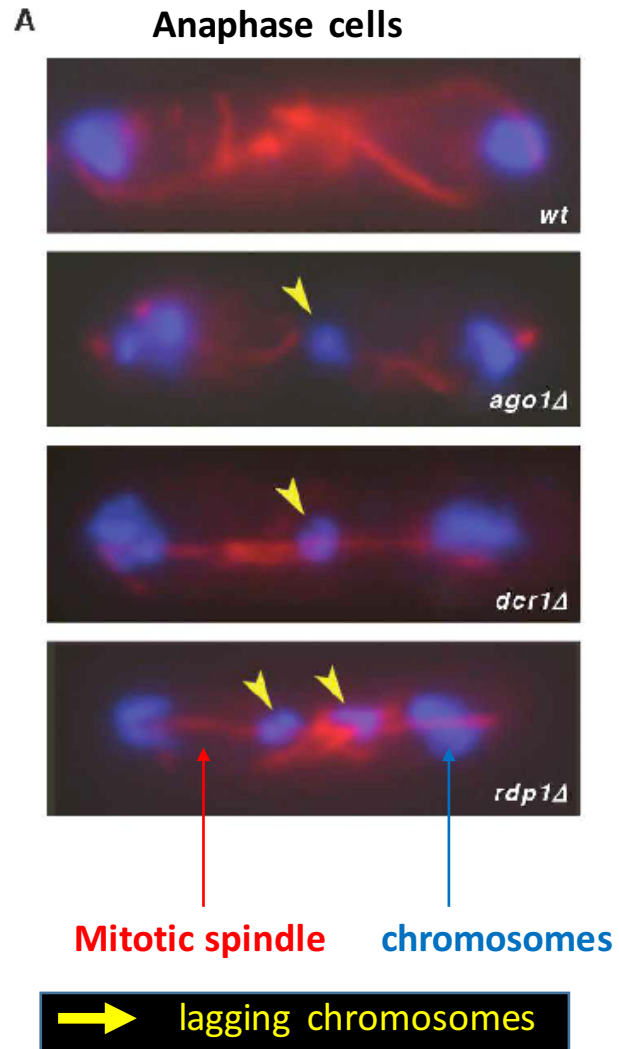

Loss of_
RNAi
machinery
Ago1
Dcr1
Swi6
Clr4



Chromosome segregation defects:

- Loss of chromosomes
- Lagging anaphase chromosomes
- Sister chromatid cohesion defects

Heterochromatin is essential for controlled chromosome segregation

Eukaryotic centromeres hold together sister chromatids until chromosome segregation

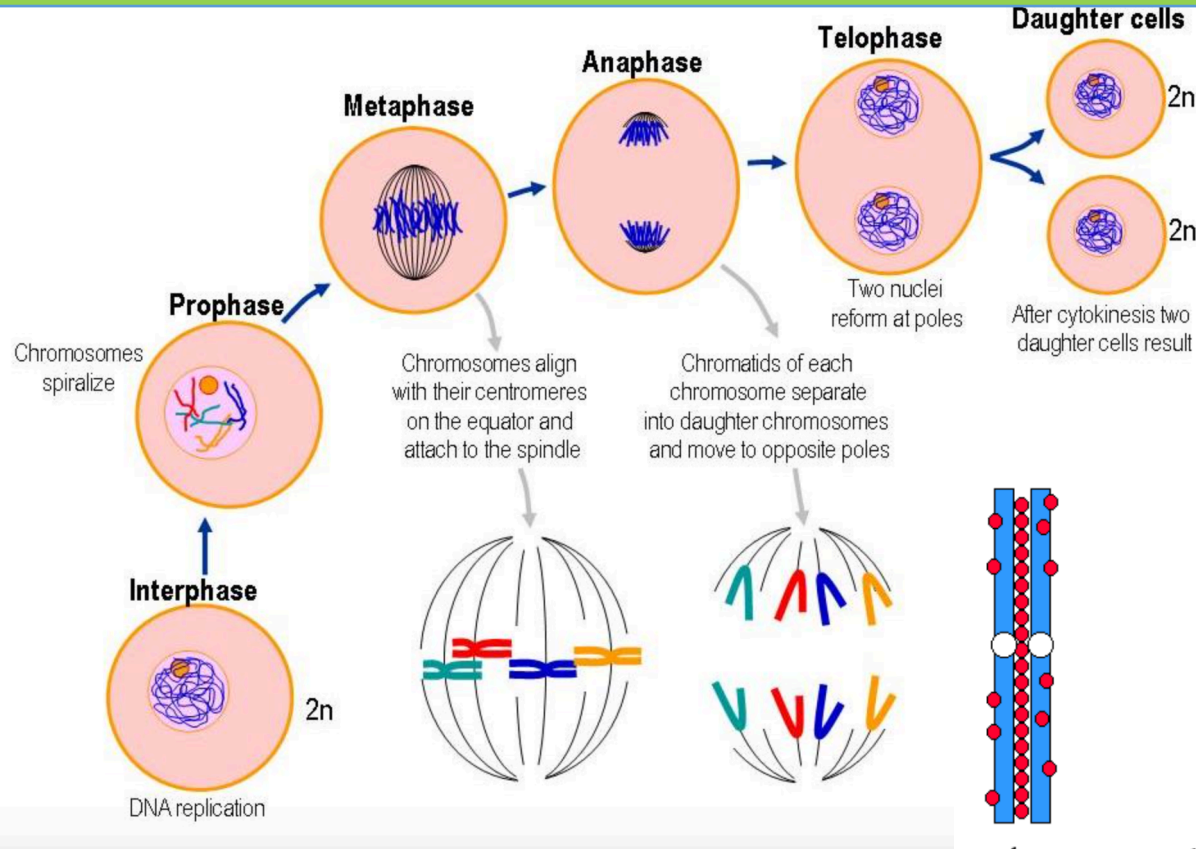

Chromocenters, aggregation of centromeres

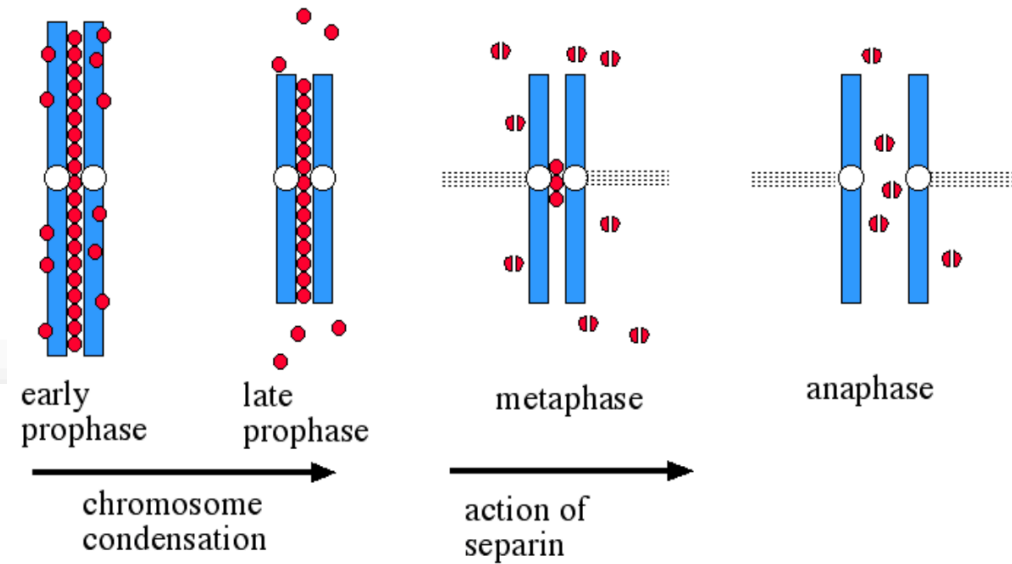
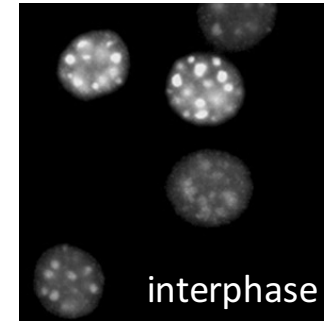

● = cohesin complex

Amon, A. (2001). "Together until separin do us part." *Nat Cell Biol* 3(1): E12-4.

WHY IS CENTROMERIC HETEROCHROMATIN IMPORTANT?

Cohesin forms a ring around sister-chromatids to organize chromosome segregation
 cohesin at centromere is very resistant and is thought to hold chromosomes well together until the spindle is perfectly attached to kinetochores

▣ WILD TYPE:
 Bioriented sister centromeres

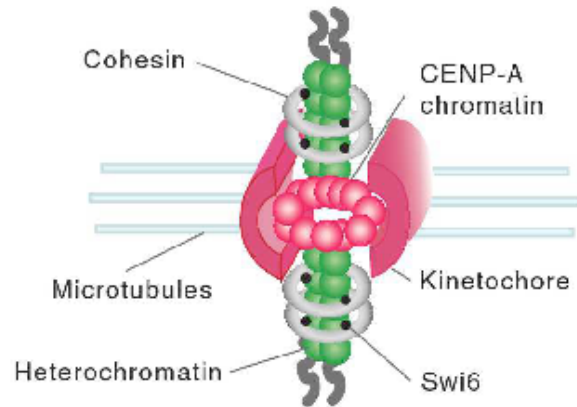

Defective heterochromatin:
 Merotelically oriented single centromere

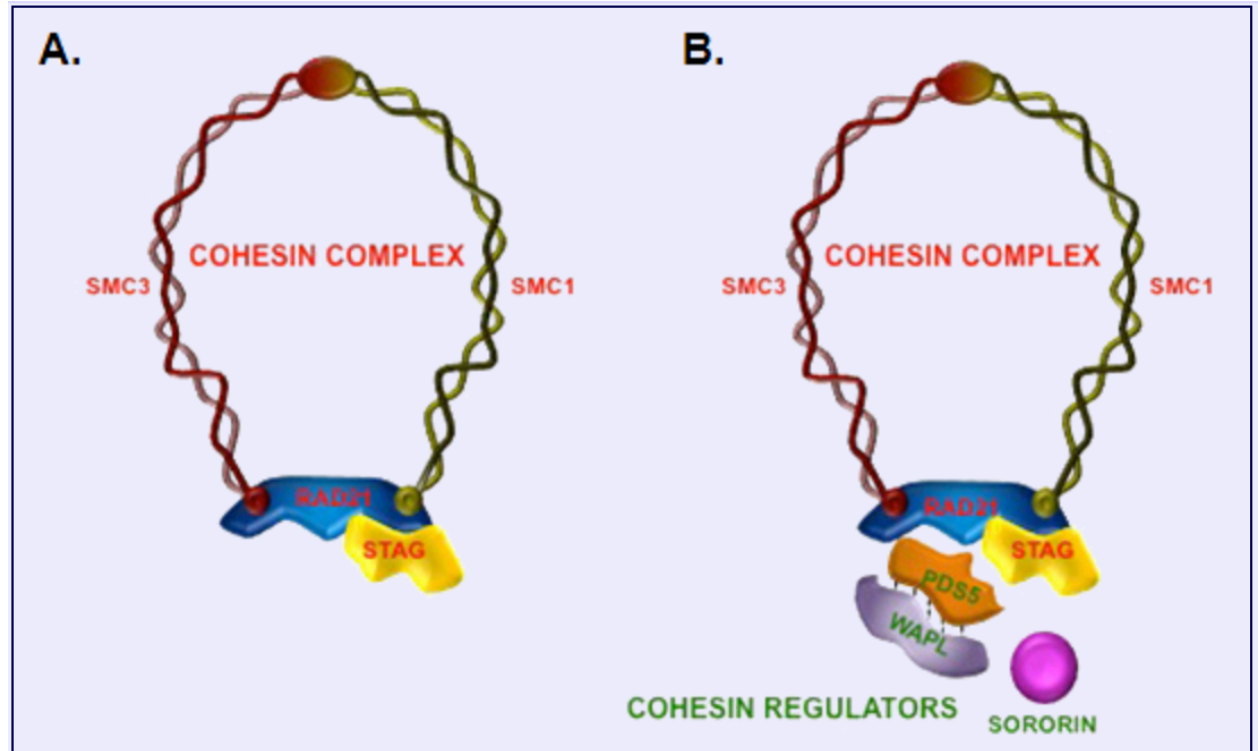
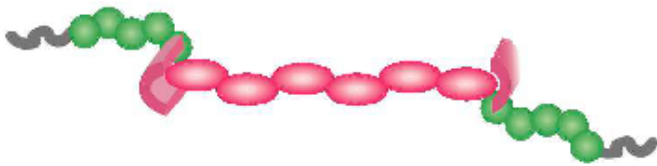

Centromeric heterochromatin is required to load cohesin to centromeres

WHY IS CENTROMERIC HETEROCHROMATIN IMPORTANT?

Swi6 is required to recruit cohesin subunit Rad21 to centromeres.....

→ Centromeric heterochromatin is required to recruit cohesin to centromeres

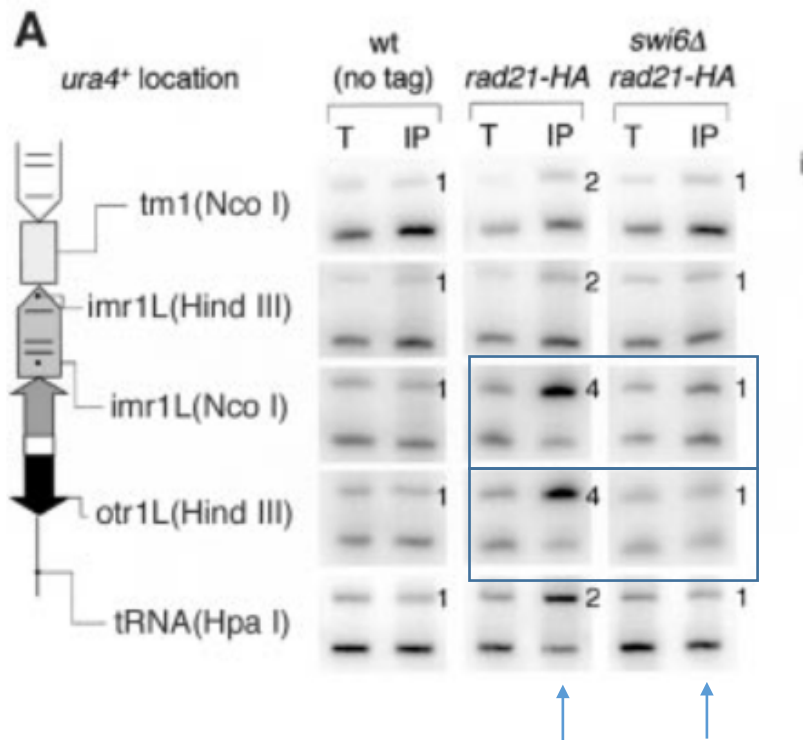

S. pombe: Wt
 S.pombe: wt+HA-rad21
 S.pombe: Swi6-/- HA-rad21

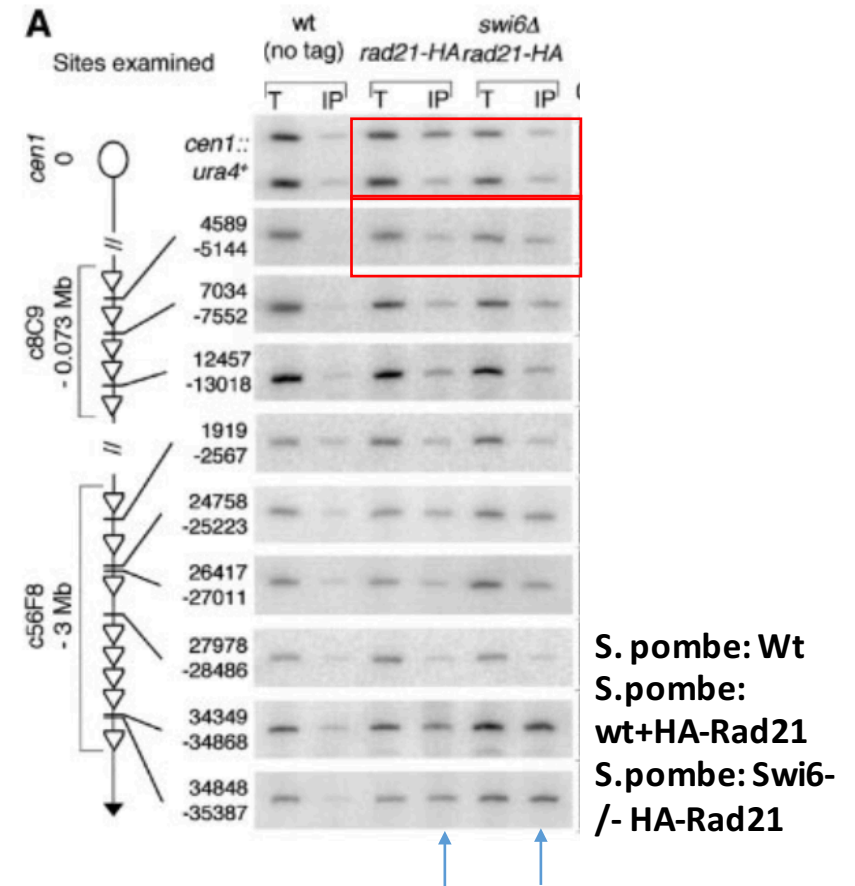

... but Swi6 is not important to recruit cohesin subunit Rad21 to other chromosomal positions

Pericentric heterochromatin in vertebrates: the mouse as a model system

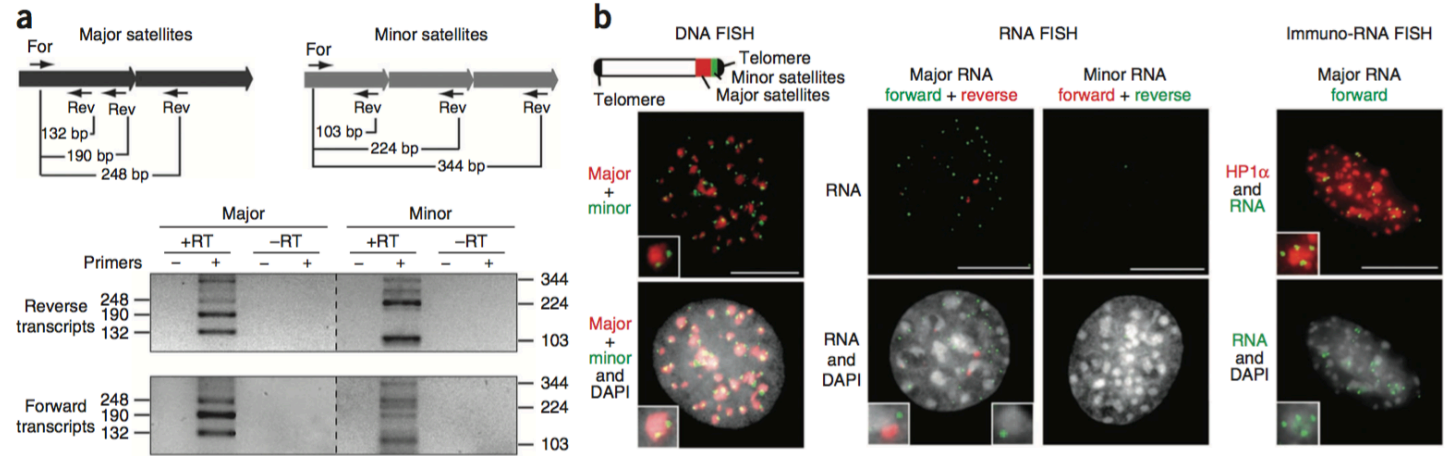
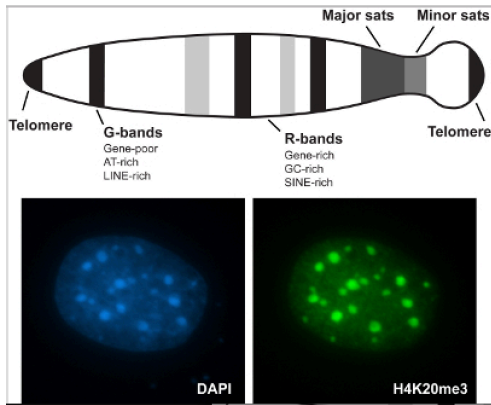

Suv39h1/h2 \rightarrow H3K9me3 + HP1
 H3K9me3 calls in Suv420h
 Suv420h1/h2 \rightarrow H4K20me3
 DNA methylation
 Bi-directional transcription of satellite repeats

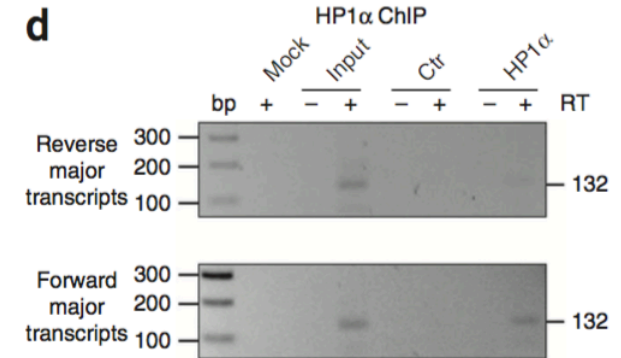
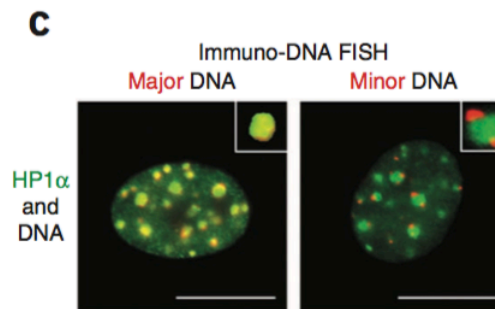

Mouse pericentric repeats are transcribed in sense anti-sense orientation

Pericentric heterochromatin in vertebrates: the mouse as a model system

A role of pericentric RNAs in heterochromatin formation

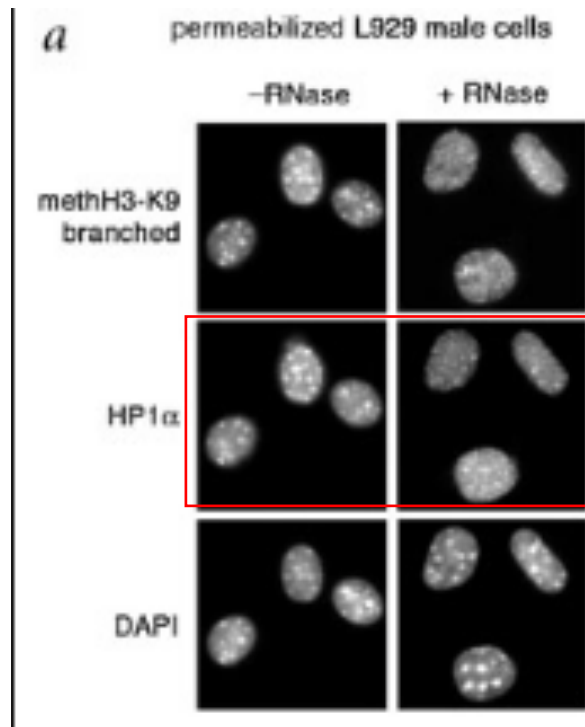

Digestion of RNAs from permeabilized cell results in a loss of HP1 from pericentric heterochromatin

A role for Dicer at mouse centromeres??

Loss of dicer: more major and minor satellite transcripts (long)...and less small minor-satellite RNAs

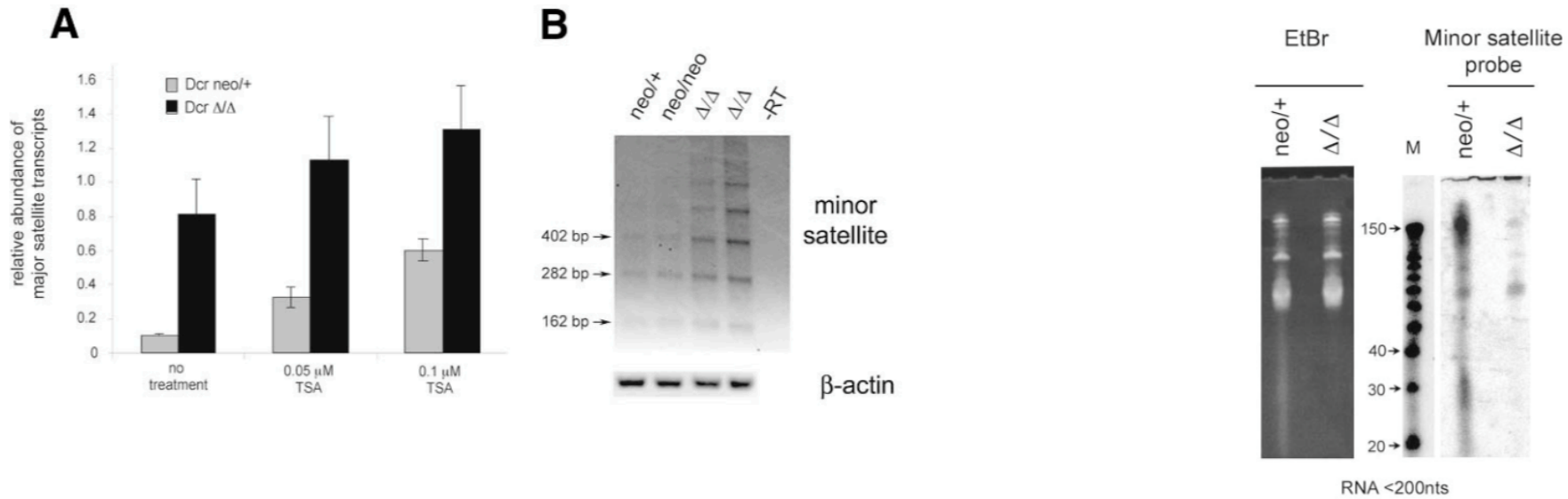

A role for Dicer at mouse centromeres??

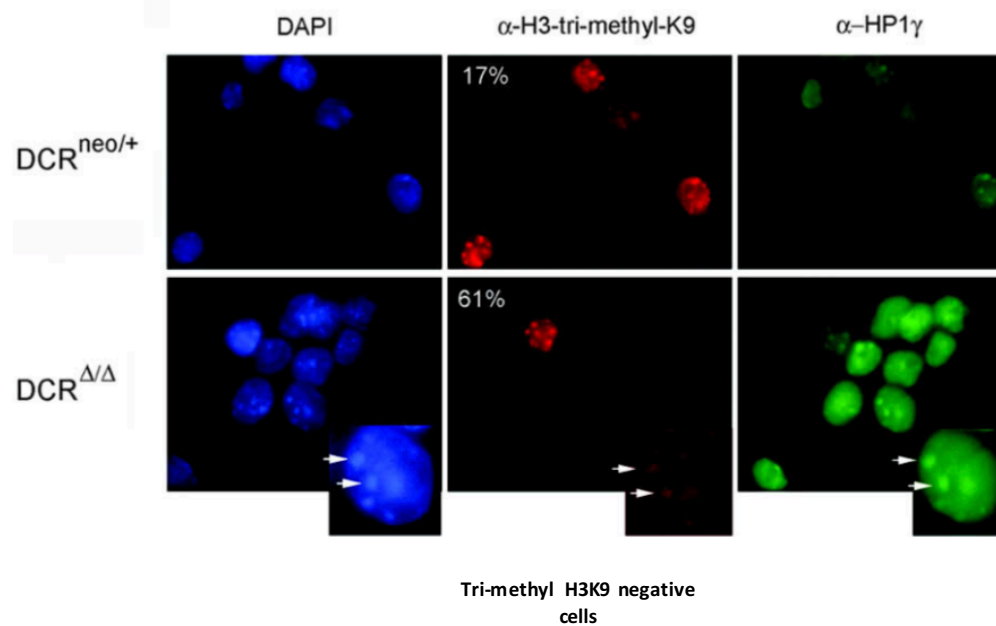

Loss of dicer reduces
H3K9me3 and HP1 heterochromatin but
**DOES NOT HAVE AN IMPACT ON
CHROMOSOME SEGREGATION**

**DICER IS DISPENSABLE FOR
HETEROCHROMATIN FORMATION**

A role for Dicer at mouse centromeres??

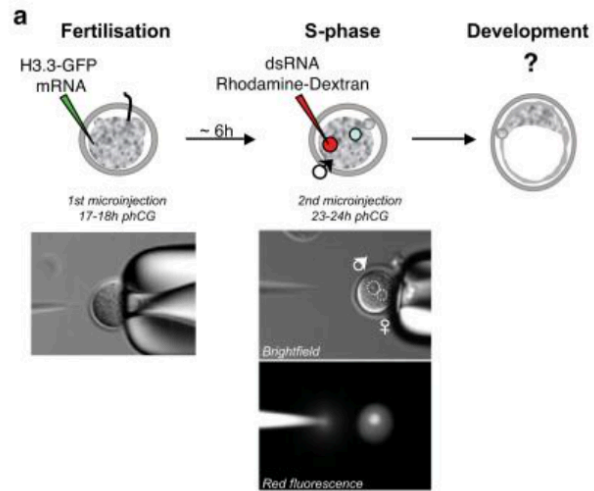

Injection of mutant H3.3 (histone variant) → loss of HP1 accumulation at pericentric heterochromatin

In injection of dsRNA from pericentric major satellite Repeats → rescue of HP1 at pericentric heterochromatin

→ Evidence for RNAi in mammalian centromeric HC formation

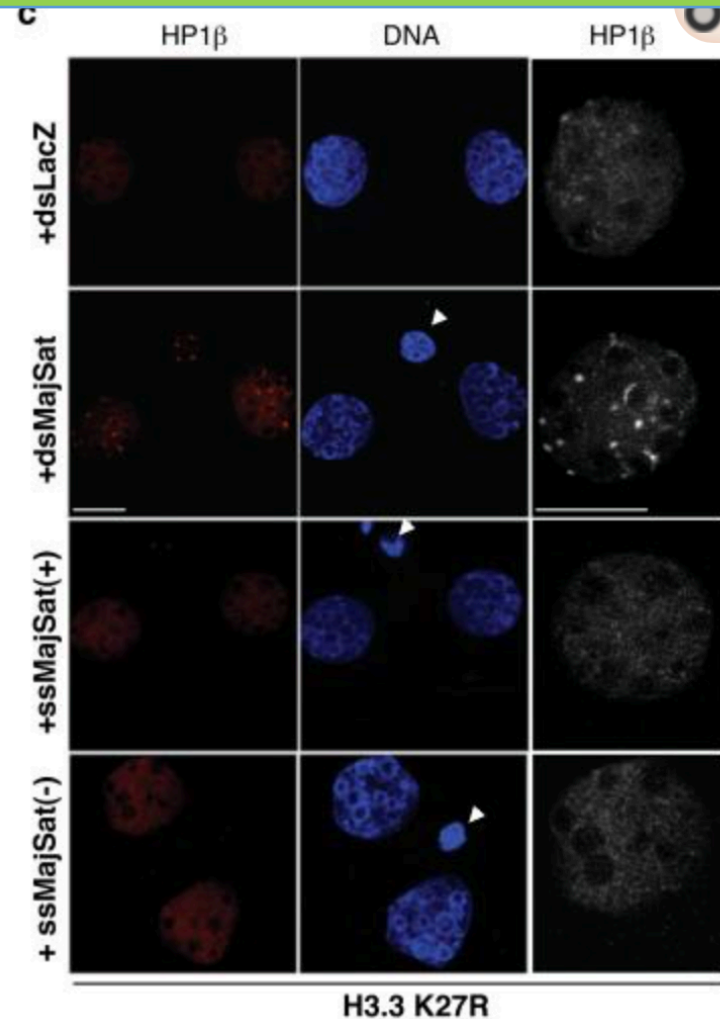

A role for Dicer at mouse centromeres??

Suv39h1/h2 KO

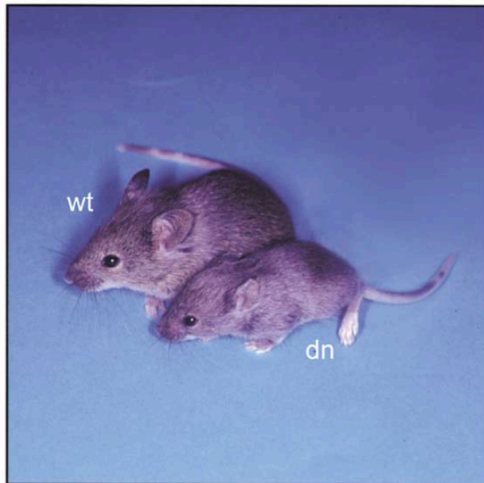

Suv39h1/h2 dn mice are smaller

Loss of pericentric H3K9 tri-methylation
And abnormal H3S10 phosphorylation

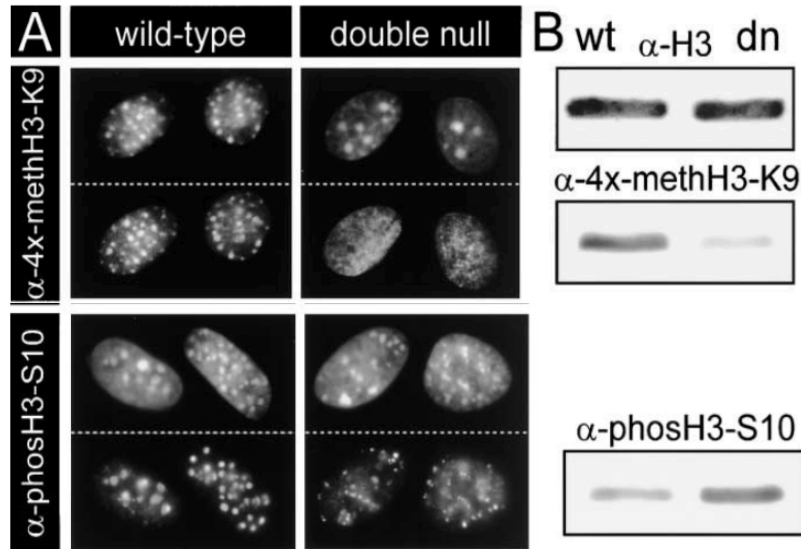

FACS – scan: loss of Suv39h1/2 results
in aneuploidy – increased chromosome
numbers

