

Drug Discovery and Development

Molecules to Materials to Medicines

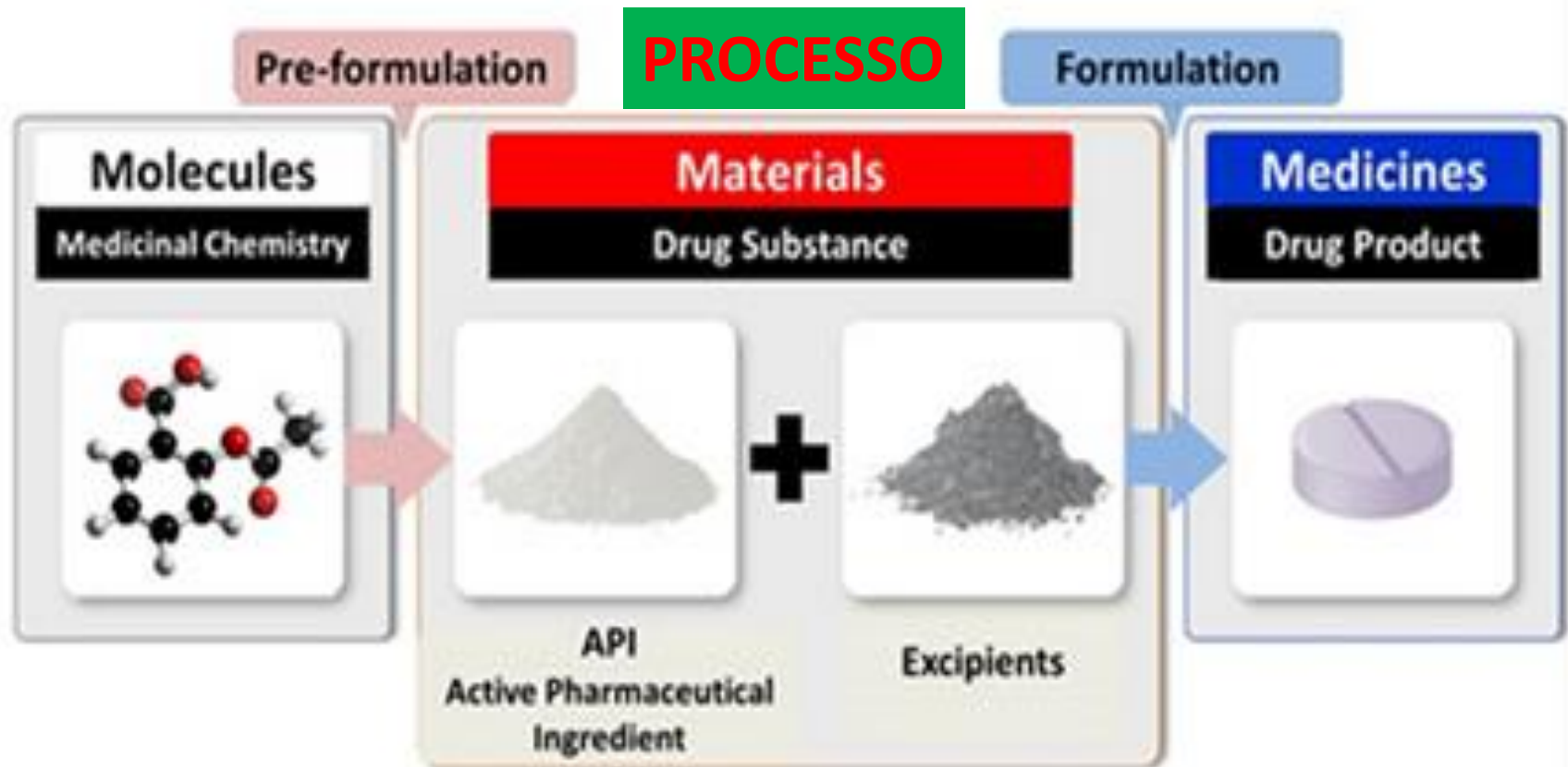

2. GRANULAZIONE

2. GRANULAZIONE

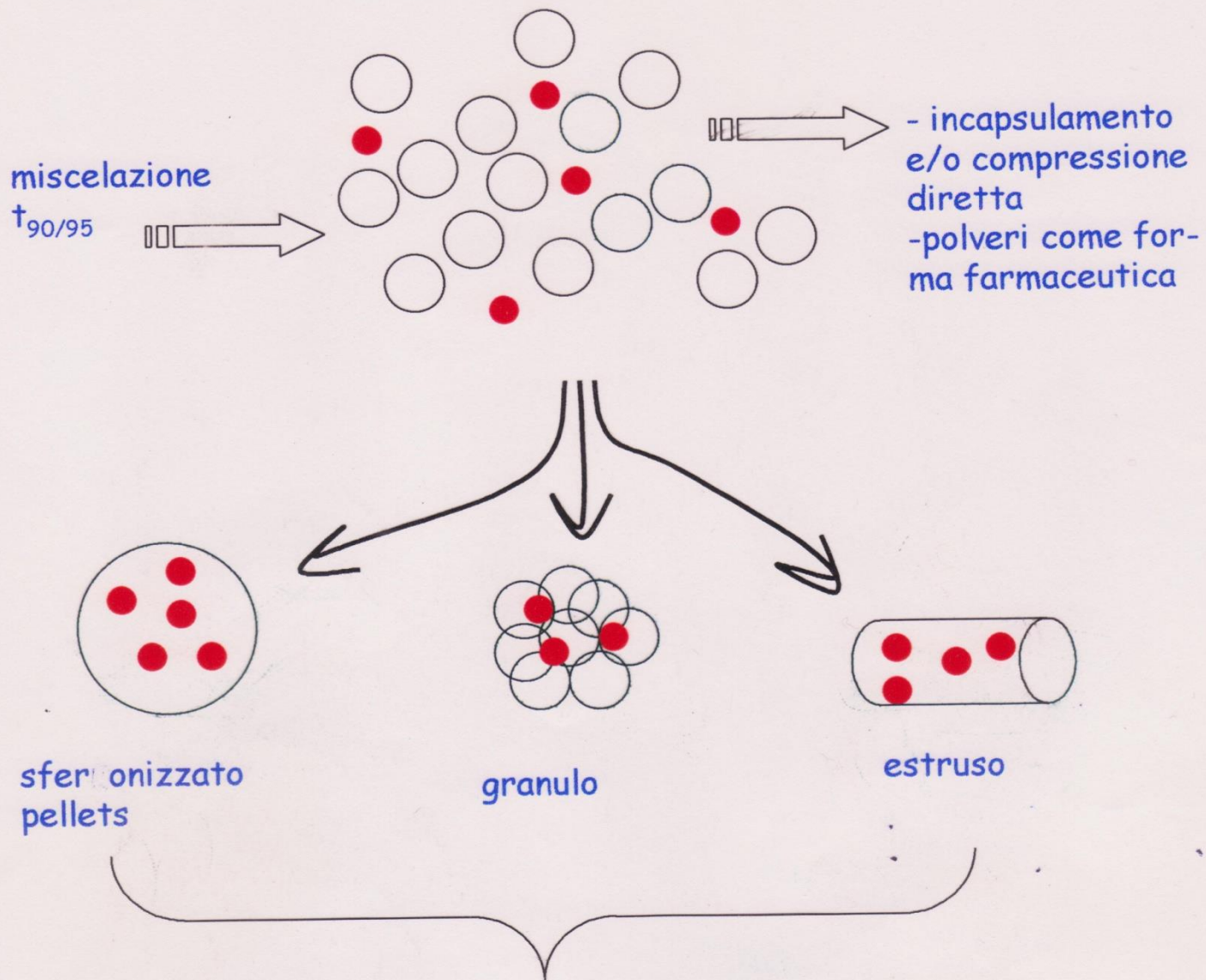

SFERONIZZATO/PELLETS

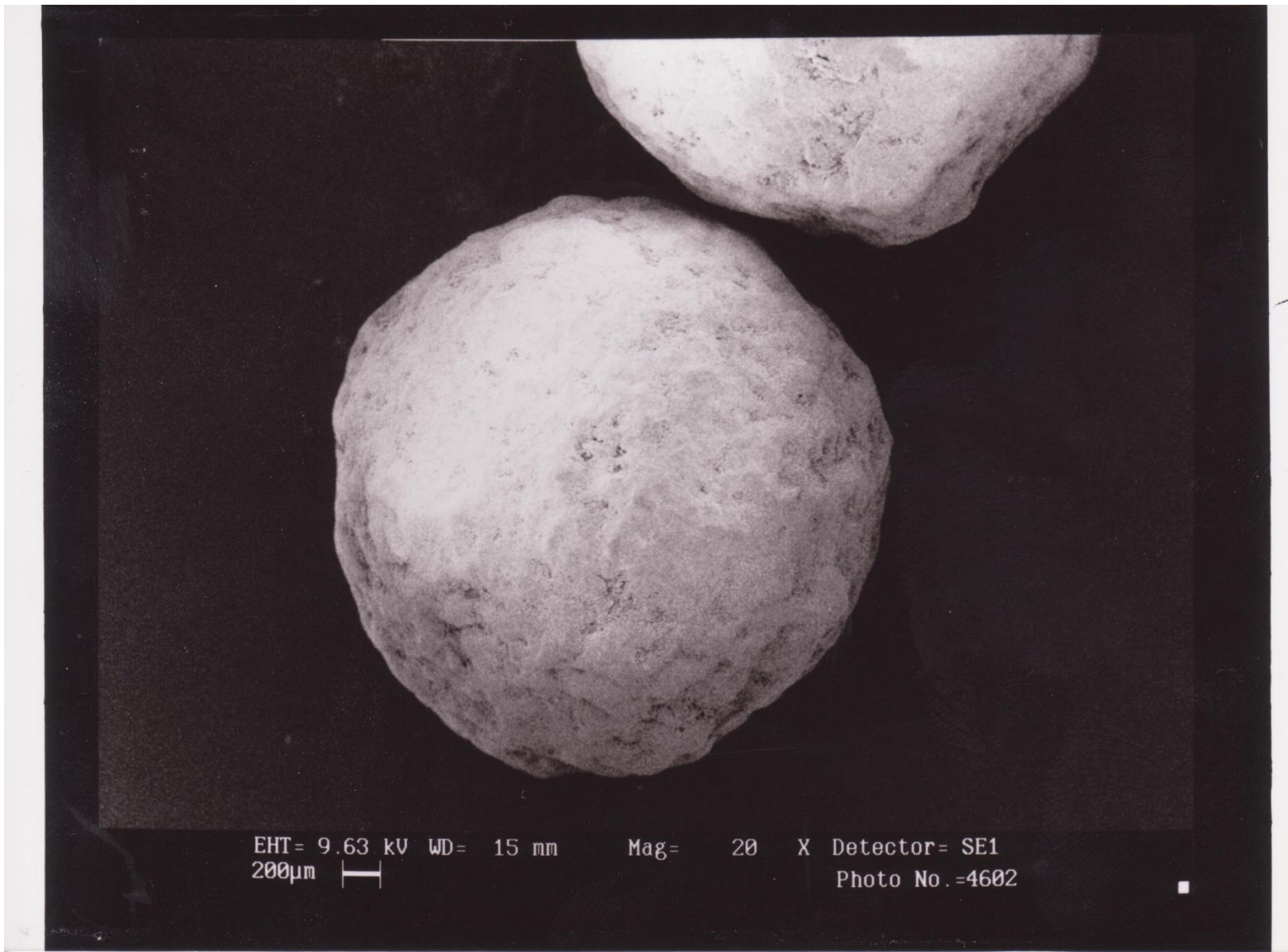

PELLETS

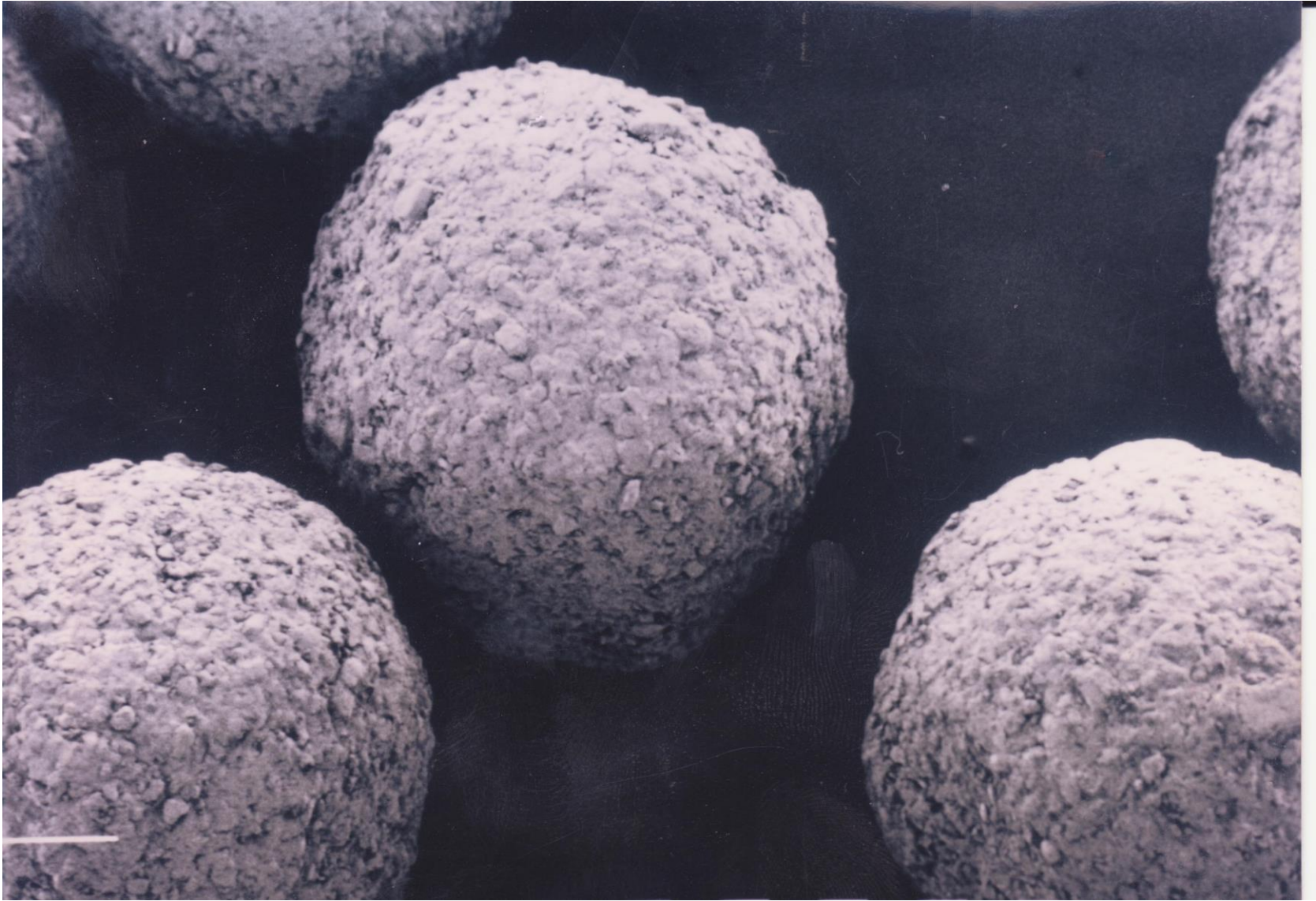

GRANULO



ESTRUSO



PERCHÈ GRANULIAMO?

- **AUMENTARE LA SCORREVOLEZZA DEL MATERIALE (UNIFORMITÀ DI MASSA): FORMA**
- **DISTRIBUZIONE PIÙ UNIFORME DEL P.A. NELLA MISCELA DI POLVERI**
- **PREVENIRE FENOMENI DI SEGREGAZIONE**
- **AUMENTARE LA DENSITÀ APPARENTE**
- **RIDURRE LA TENDENZA DELL'AMMASSAMENTO (IGROSCOPICI)**
- **MIGLIORARE LA COMPRIMIBILITÀ DELLE MISCELE**
- **RIDURRE LA DISPERSIONE DI POLVERI NELL'AMBIENTE LAVORATIVO**

➤ **AUMENTARE LA DENSITÀ
APPARENTE**



➤ **AUMENTARE LA
SCORREVOLEZZA DEL
MATERIALE (UNIFORMITÀ DI
MASSA):FORMA**



➤ **RIDURRE LA
DISPERSIONE DI POLVERI
NELL'AMBIENTE
LAVORATIVO**



ECCIPIENTI

(dalla parola latina excipere = amalgamare)

- **Gli eccipienti sono ingredienti farmacologicamente inerti aventi lo scopo di ottenere forme farmaceutiche con le caratteristiche tecnologiche e biofarmaceutiche desiderate.**
 - **“altri ingredienti” (diversi dal principio attivo).**
 - **Ciascuno di essi esplica una funzione ben definita (o più funzioni) nella formulazione.**
 - **non sono inerti dal punto di vista tecnologico.**
- Oggi si parla molto di FUNZIONALITA' degli eccipienti.**

COMPONENTI DEI GRANULATI (ECCIPIENTI)

1. DILUENTI

2. LEGANTI

3. DISGREGANTI

4. EDULCORANTI
ARTIFICIALI

5. AROMATIZZANTI

6. COLORANTI

7. AGENTI BAGNANTI

8. GLIDANTI *

9. LUBRIFICANTI *

1. DILUENTI

INSOLUBILI	SOLUBILI
CALCIO SOLFATO BIIDRATO	LATTOSIO *
CALCIO FOSFATO BIBASICO *	SACCAROSIO
CALCIO FOSFATO TRIBASICO *	DESTROSIO
CALCIO CARBONATO	MANNITOLO
AMIDO *	SORBITOLO
AMIDO MODIFICATO *	FRUTTOSIO
CELLULOSA MICROCRISTALLINA *	NaCl

2. LEGANTI

LEGANTI PIÙ COMUNEMENTE USATI	USO
AMIDO (AMIDI MODIFICATI)	MUCILLAGINE 5-10%
GELATINA	MUCILLAGINE 2-10%
SACCAROSIO	SOLUZIONE ACQUOSA 10-20%
CELLULOSA MICROCRISTALLINA	LEGANTE A SECCO
PVP	SOLUZIONE ACQUOSA, ALCOOLICA, IDROALCOOLICA 5-20%
PVA	SOLUZIONE ACQUOSA, IDROALCOOLICA 2-20%
METILCELLULOSA, ETILCELLULOSA	SOLUZIONE ACQUOSA 2-10%, SOLUZIONE IDROALCOOLICA 2-15%
SODIO ALGINATO	SOLUZIONE ACQUOSA 1-2%
PEG 6000	LEGANTE A SECCO

**PERMETTONO DI MIGLIORARE LA COESIONE DELLE PARTICELLE
NEI GRANULI**





3. DISGREGANTI

HANNO LA FUNZIONE DI DISGREGARE RAPIDAMENTE IL PRODOTTO A LIVELLO GASTRICO

DISGREGANTI	CONC. USO
AMIDO (AMIDI MODIFICATI)	5-20%
CELLULOSA MICROCRISTALLINA	5-20%
BENTONITE	5-15%
CROSPROVIDONE	1-5%
CROSCARMELLOSIO (CARBOSSOMETIL CELLULOSA RETICOLATA SODICA)	1-4%
MIX. DI AC. TARTARICO + NaHCO₃	

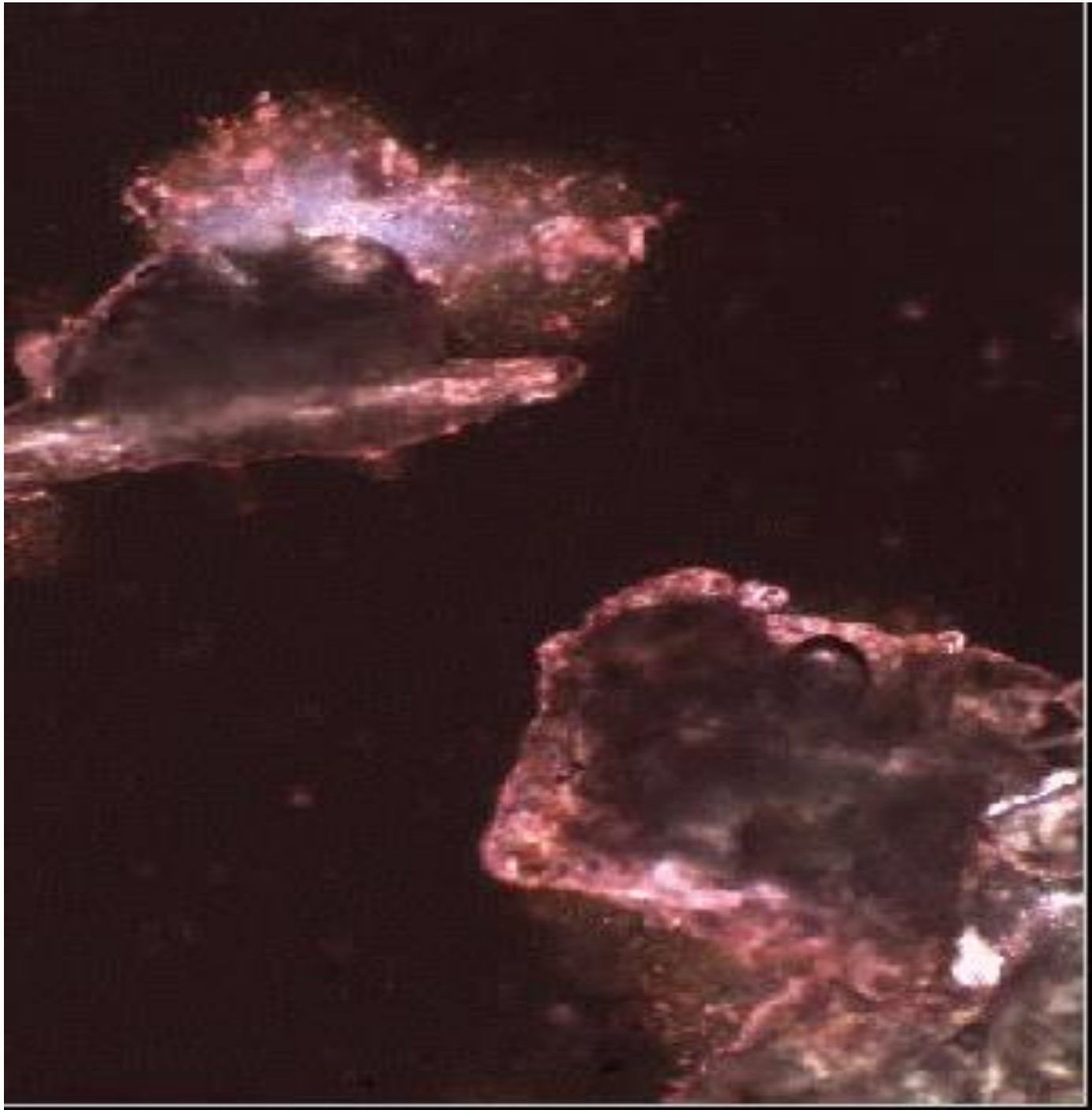

CORREZIONE DEL GUSTO

4. DOLCIFICANTI

POTERE EDULCORANTE: MASCHERARE O ATTENUARE L'EVENTUALE SAPORE SGRADIVOLE DEL PRINCIPIO ATTIVO

ZUCCHERI:

- LATTOSIO 0.2
- MALTOSIO 0.3
- GLUCOSIO 0.7
- SACCAROSIO **1**
- FRUTTOSIO* 1.3-1.7

POLIALCOLI:

- ❖ MANNITOLE 0.5
- ❖ SORBITOLE 0.6
- ❖ XILITOLE* **1**

ESTRATTI VEGETALI:

- AMMONIO GLICIRRIZINATO **50**

SINTETICI:

- ASPARTAME **100**
- SACCARINA SODICA **300**

CORREZIONE DEL GUSTO

5. AROMATIZZANTI

IDROSOLUBILI (INSTABILI):

- SUCCHI DI FRUTTA CONCENTRATI
- IDROLATI O ALCOOLATI

LIPOSOLUBILI:

- OLII ESSENZIALI DI MENTA
PIPERITA, FINOCCHIO, LIMONE,
ARANCIO.

PREPARAZIONE (DA LIQUIDO A SOLIDO)

1. POLVERI ATOMIZZATE (spray drying/maltodestrine)

EMULSIONE O/A DI GELATINA E DESTRINE →
SPRAY DRYING → POLVERE FINE
MICROINCAPSULATA → 20% OLII ESSENZIALI



SPRAY-DRYING (ESSICCAMENTO PER NEBULIZZAZIONE)

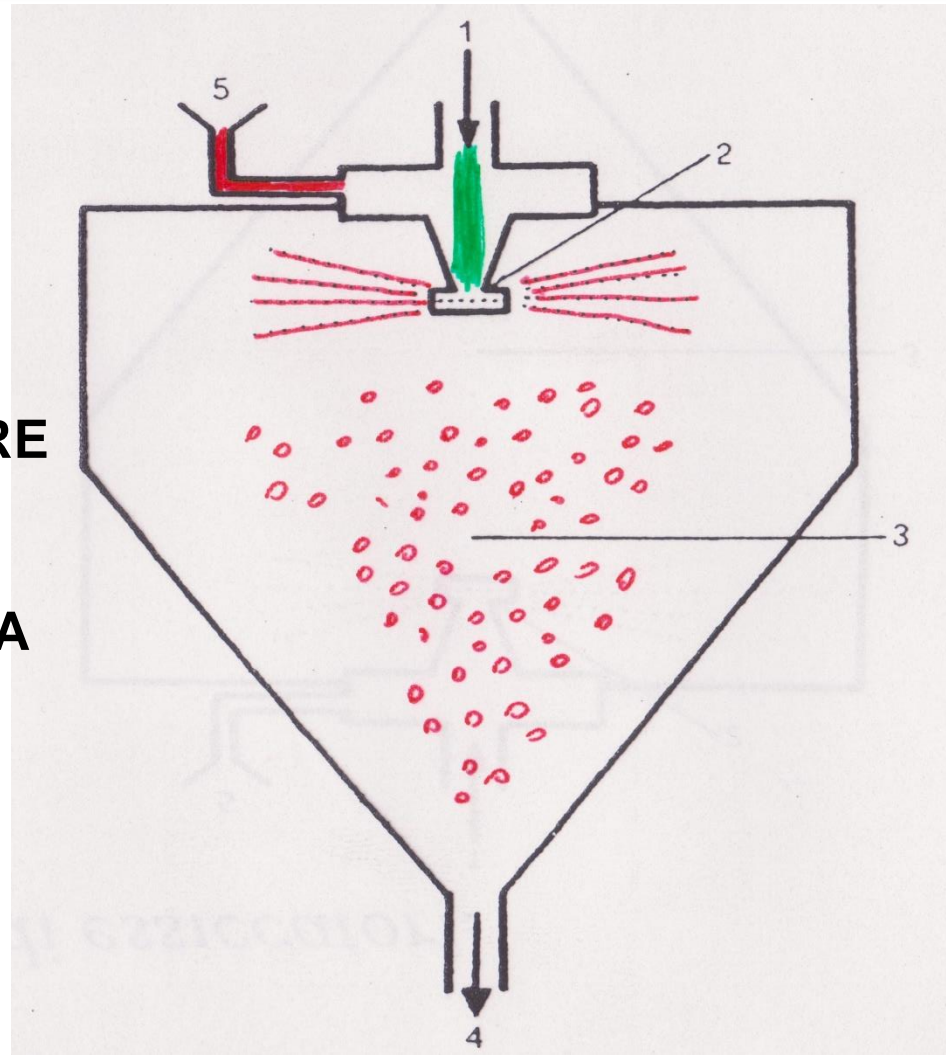

1. ENTRATA
DELL'ARIA
CALDA

2. ATOMIZZATORE

5. ENTRATA
PRODOTTO DA
ESSICCARE

3. CAMERA DI
ESSICCAMENTO

4. USCITA DEL
MATERIALE

**2. OLII ESSENZIALI → FATTI
ADSORBIRE SU GEL DI SILICE**

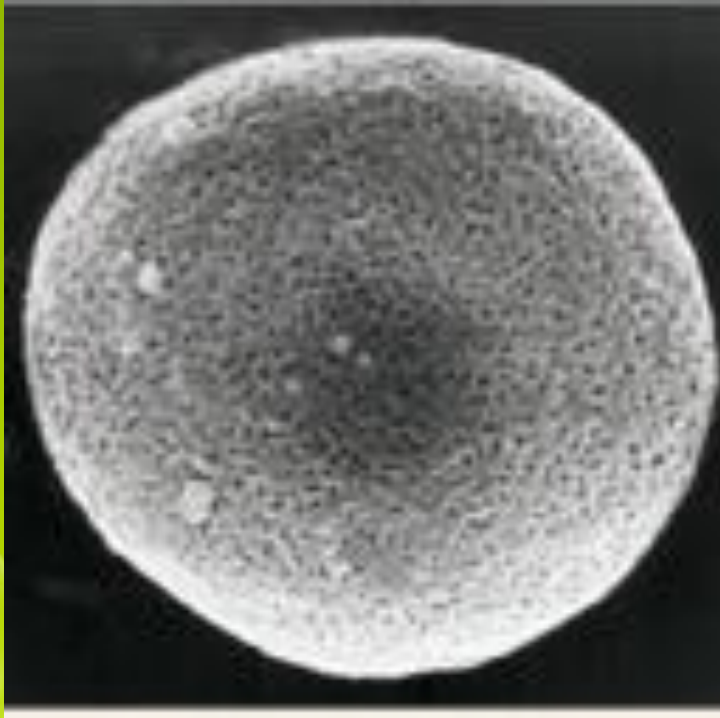

70%

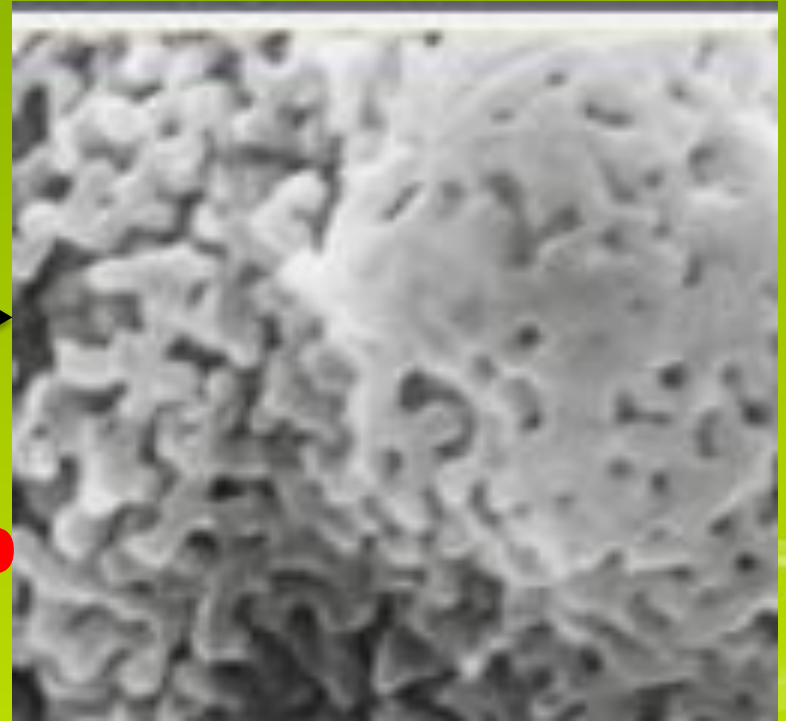

200-400 m²/g

6. COLORANTI

AUTORIZZATI QUELLI PER USO ALIMENTARE (IDRO/LIPOSOLUBILI)

NELLA FORMULAZIONE DI FORME FARMACEUTICHE SOLIDE SI UTILIZZANO:

1. LACCHE DI ALLUMINIO (COLORANTE ADSORBITO SU OSSIDO DI ALLUMINIO)
2. OSSIDI DI FERRO (ROSSO-GIALLO-NERO)

Colori e aromi corrispondenti

Colore

Aroma

Da rosa a rosso
Bruno

Ciliegia, tutti frutti, fragola, mela, lampone
Cioccolato, miele, melassa, noce, nocciola,
caramello

Da giallo ad arancio

Limone, cedro, arancio, agrumi misti, crema,
banana, ciliegia

Verde

Cedro, menta, mentolo, menta piperita,
pistacchio

N.EC	Colore	Concentrazione %
E 102	LACCA DI TARTRAZINA	35-42
E 102	LACCA DI TARTRAZINA	24-28
E 102	LACCA DI TARTRAZINA	14-16
E 104	LACCA DI CHINOLINA	18-24
E 110	LACCA DI TRAMONTO	35-42
E 110	LACCA DI TRAMONTO	20-25
E 122	LACCA DI AZORUBINO	20-26
E 123	LACCA DI AMARANTO	20-25
E 124	LACCA DI PONCEAU 4R	31-37
E 124	LACCA DI PONCEAU 4R	19-25
E 127	LACCA DI ERITROSINA	30-38
E 127	LACCA DI ERITROSINA	17-23
E 129	LACCA DI ROSSO ALLURA	35-42
E 127	LACCA DI ROSSO ALLURA	28-34
E 131	LACCA DI BLU PATENT	8-12
E 132	LACCA DI INDIGOTINA	9-15
E 133	LACCA DI BLU BRILLANTE FCF	35-42
E 133	LACCA DI BLU BRILLANTE FCF	10-14
E 151	LACCA DI NERO BRILLANTE BN	30-35

Colore

LACCA DI VERDE MELA

LACCA DI VERDE SCURO

LACCA DI VERDE LIME

LACCA DI BRUNO CIOCCOLATO CHIARO

LACCA DI BRUNO CIOCCOLATO

LACCA DI BRUNO CIOCCOLATO SCURO

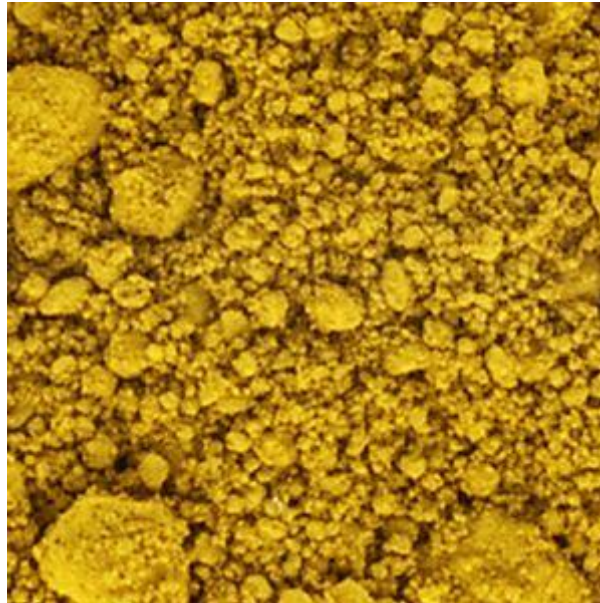
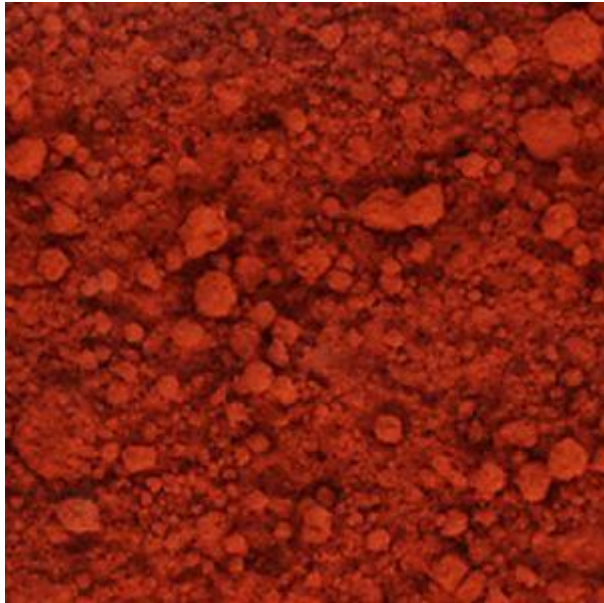

OSSIDI DI FERRO

7. AGENTI BAGNANTI

TENSIOATTIVI

ESTERI DEL SORBITANO * (SPAN)

POLISORBATI * (TWEEN)

SODIO LAURILSOLFATO-lubrificante

DOCUSATO DI SODIO

GLICERIL MONOLEATO/STEARATO*

POLIMERI IDROFILI A BASSA VISCOSITÀ

IDROSSIPROPILMETILDERIVATI
DELLA CELLULOSA*

* AGENTI BAGNANTI NON IONICI

8. AGENTI ANTIFRIZIONE (LUBRIFICANTE, GLIDANTE, ANTIADERENTE)

LUBRIFICANTE:

LUBRIFICA LE PARETI DELLA MATRICE (CONTATTO POLVERE-PARTE MECCANICA)

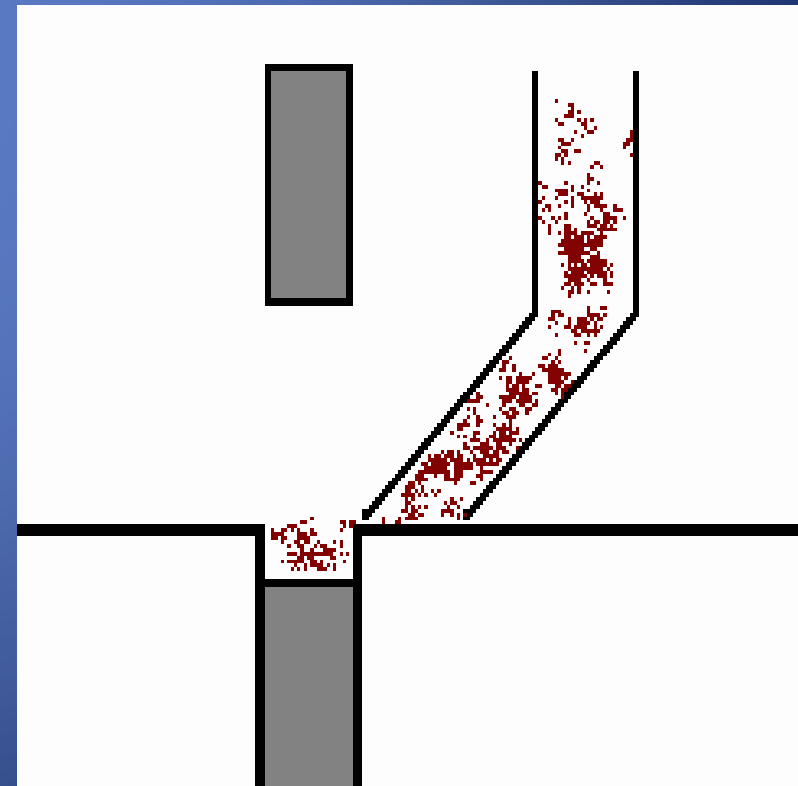
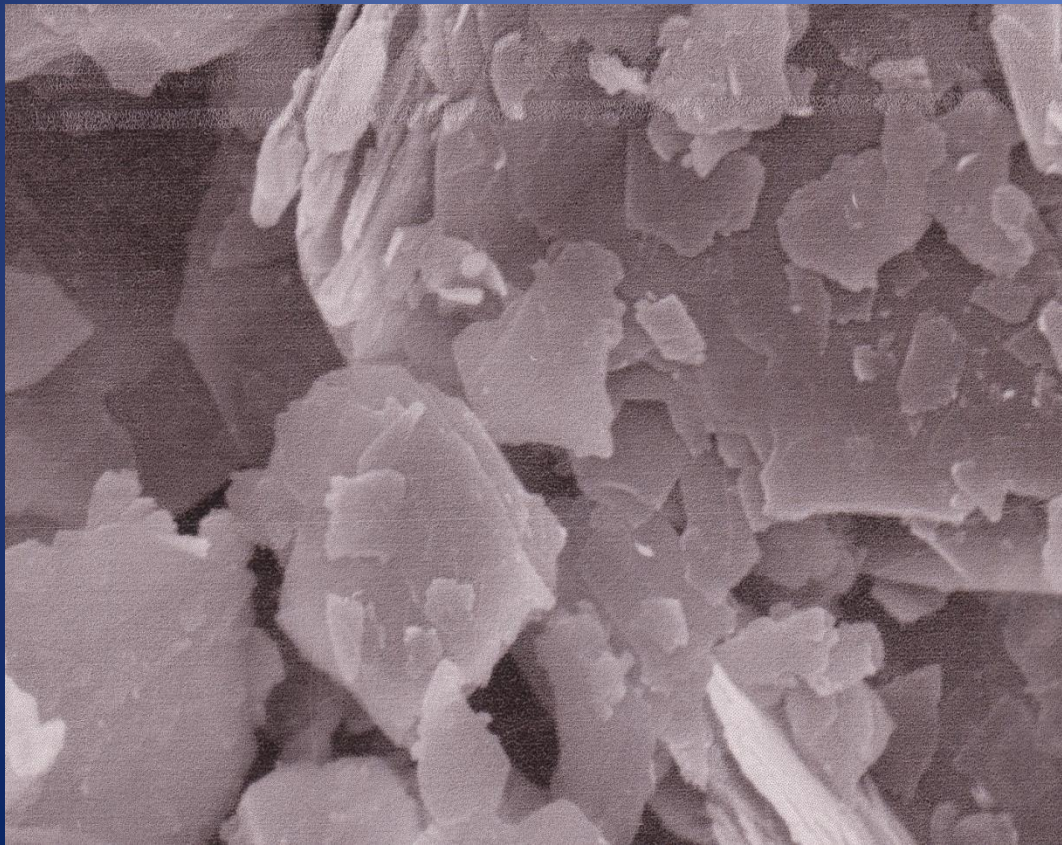

GLIDANTE: RIDUCE LE FORZE COESIVE TRÀ LE PARTICELLE

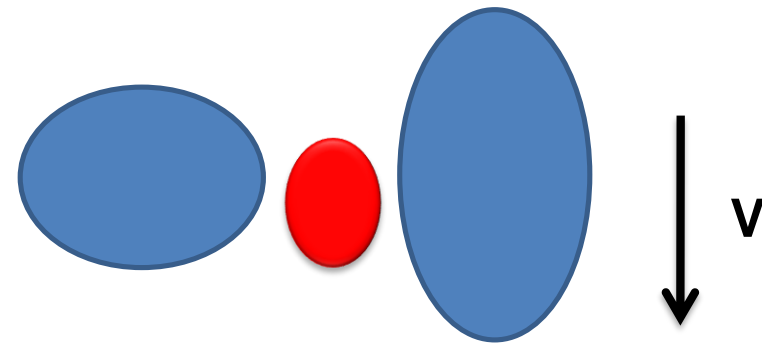
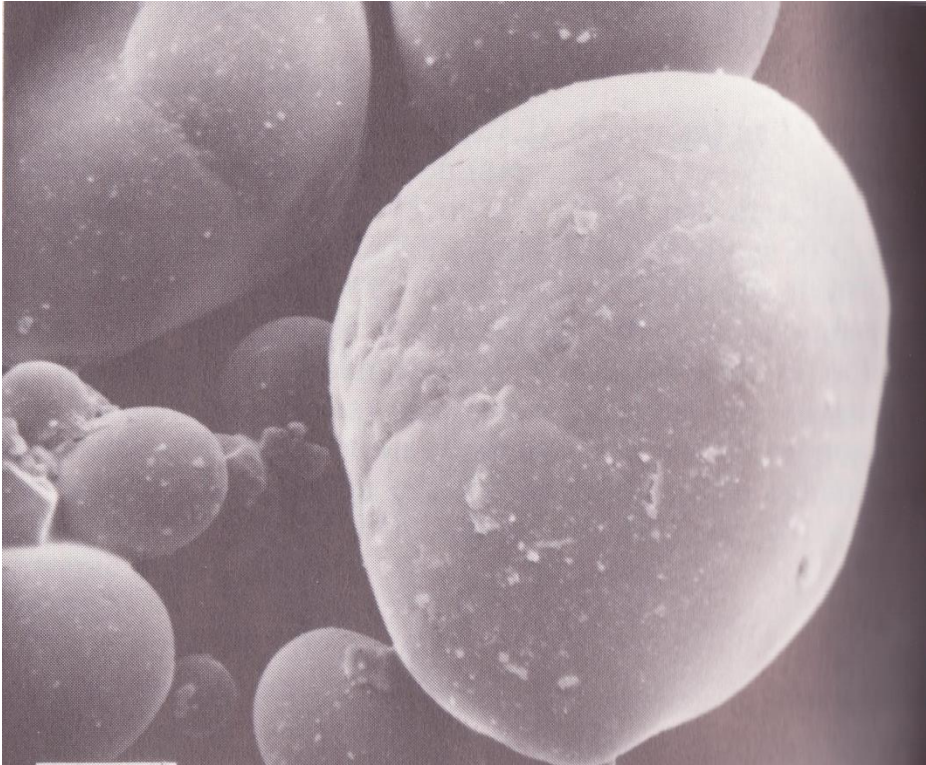

F.U. MIGLIORARE LO SCORRIMENTO DEI GRANULI

**POTERE ANTIADERENTE:
DIMINUIRE L'ADESIONE DEL
MATERIALE AI PUNZONI ED ALLE
PARETI DELLA MATRICE**

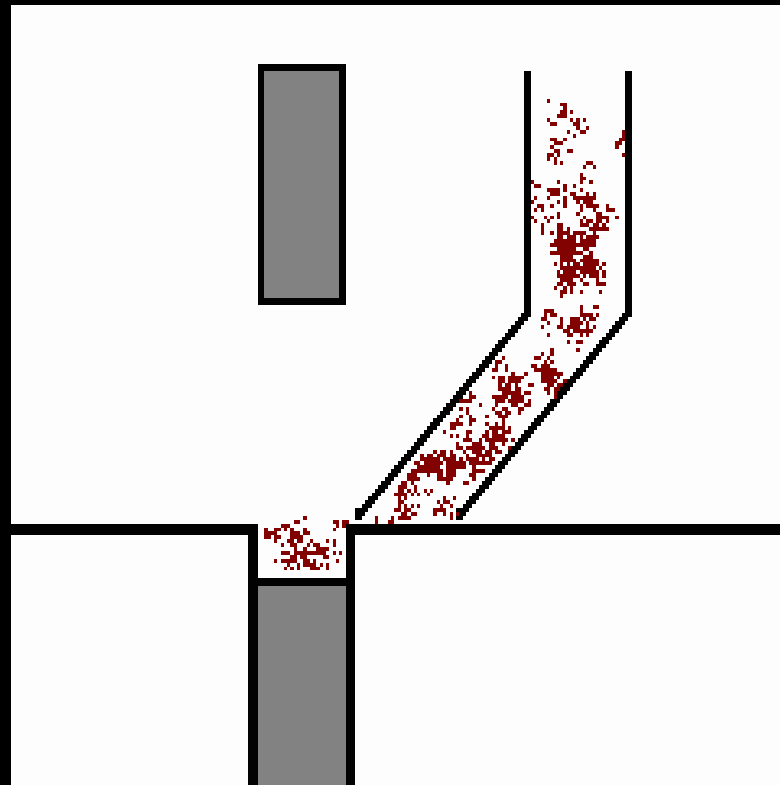

PROPRIETÀ COMPARATIVE DI ALCUNI AGENTI ANTIFRIZIONE

INSOLUB. IN ACQUA

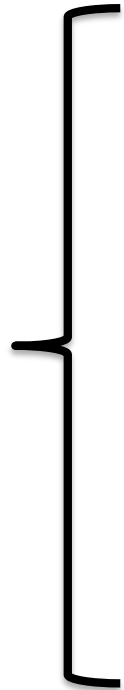

MATERIALE	AZIONE GLIDANTE	AZIONE ANTIADERENTE	AZIONE LUBRIFICANTE
STEARATI METALLICI	/	BUONA	OTTIMA
TALCO	BUONA	OTTIMA	/
AC. STEARICO	/	/	BUONA
CERE	/	/	OTTIMA
AMIDO	OTTIMA	OTTIMA	/
SILICE	OTTIMA	/	/
OLIO DI PARAFFINA	/	/	OTTIMA
PEG	/	/	OTTIMA
SODIO BENZOATO	/	/	OTTIMA

SOLUB IN ACQUA

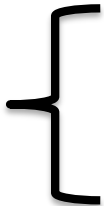

METODI GRANULAZIONE

1. A SECCO:

- **MEDIANTE RULLI (GRANULATORE OSCILLANTE)**
- **MEDIANTE COMPRIMITRICI TRADIZIONALI**

2. AD UMIDO:

- **IMPASTO E GRANULAZIONE ATTRAVERSO RETI / IN GRANULATORI RAPIDI**
- **LETTO FLUIDO**
- **ESTRUSIONE-SFERONIZZAZIONE**
- **SPRAY-DRYING**
- **BASSINA**
- **GRANULAZIONE PER FUSIONE**

1. GRANULAZIONE A SECCO

- UTILIZZATA PER PRODOTTI TERMOLABILI O CHE VANNO INCONTRO A IDROLISI (ACQUA O SOLVENTI ORGANICI)
- CONVENIENTE DAL PUNTO DI VISTA ECONOMICO (ALTA PRODUTTIVITÀ CON BASSI COSTI)
- PROBLEMI DI PROCESSO PERCHÉ SPESSO LE POLVERI NON POSSIEDONO UNA SUFFICIENTE FORZA DI COESIONE (AGGIUNTA DI SOSTANZE LEGANTI: PEG 6000, MCC, LATTOSIO SPRAY-DRYING).

FASI DELLA GRANULAZIONE A SECCO

COMPATTATORE A RULLI

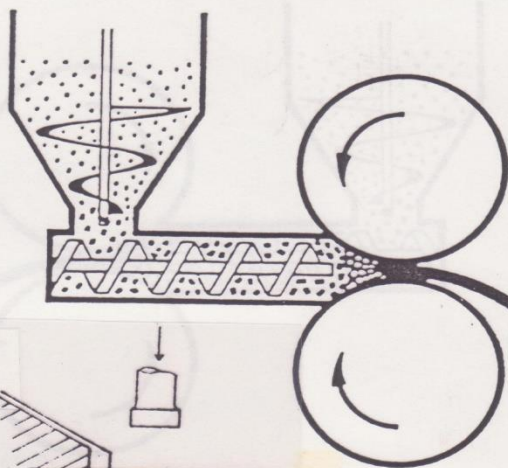

COMPRESSORI

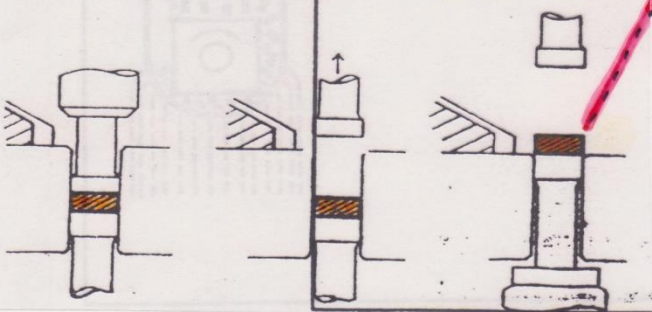
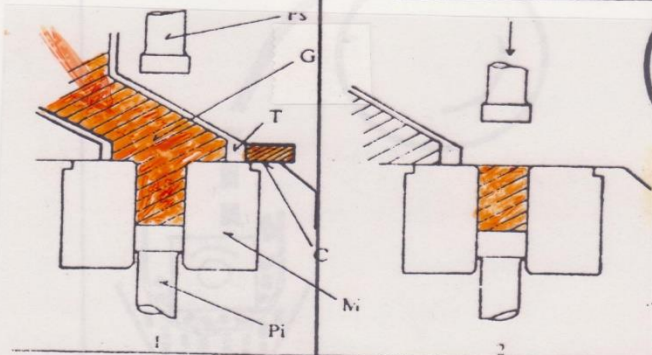

GRANULATORE OSCILLANTE

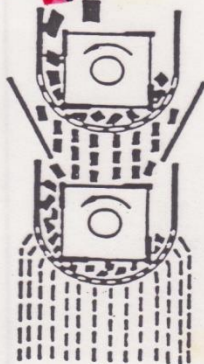

FORMELLE O SCAGLIE

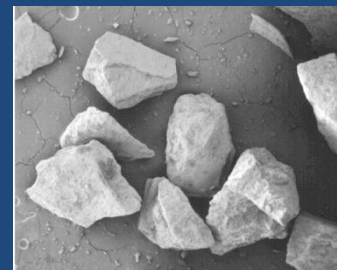

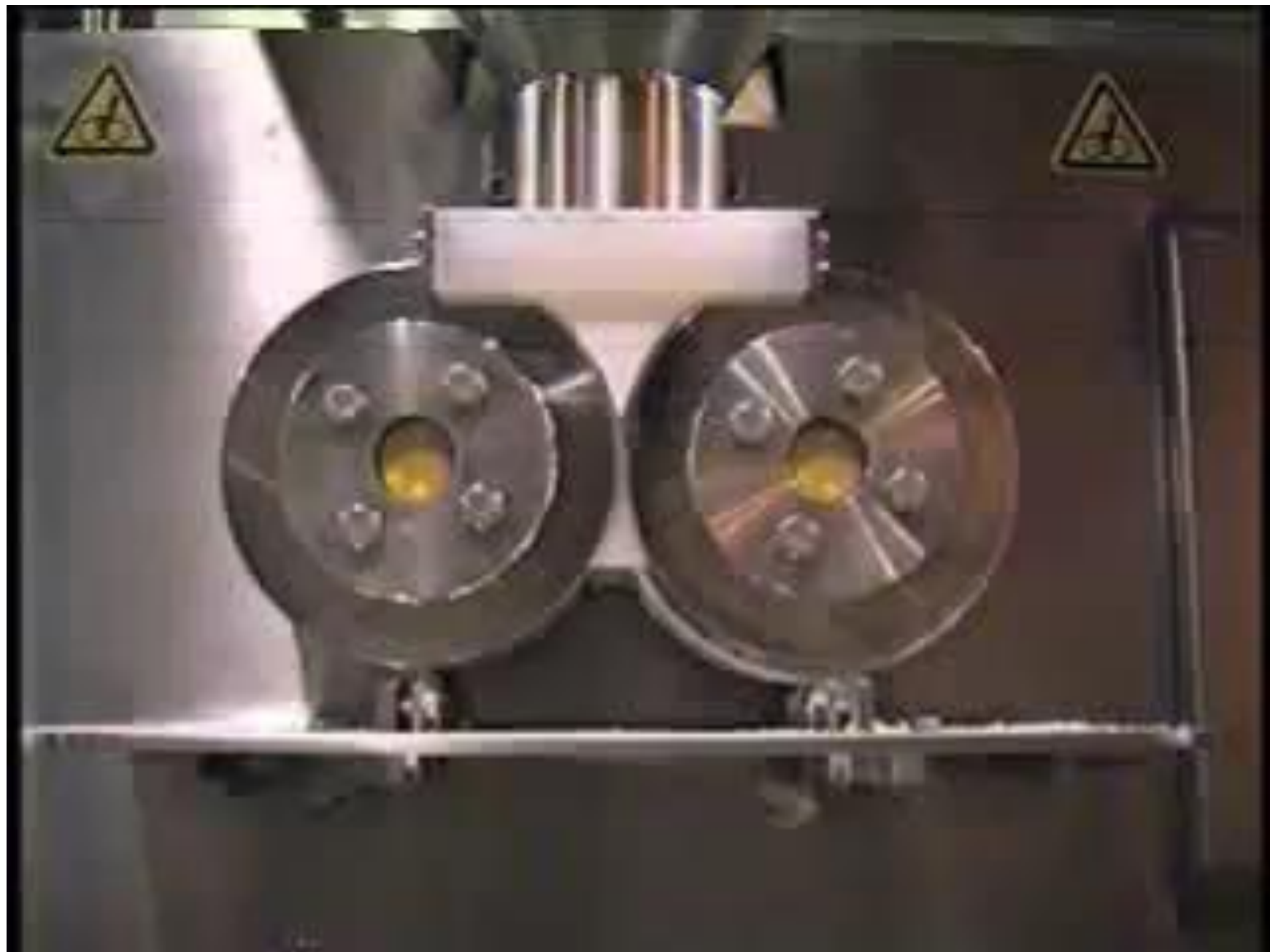

MECCANISMI DI LEGAME

1. FORZE DI INTERCONNESSIONE (INGREDIENTI A STRUTTURA MICROFIBROSA)
2. FORZE DI ATTRAZIONE FRA PARTICELLE SOLIDE (ELETTROSTATICHE, VAN DER VAALS)
3. PONTI SOLIDI PER FUSIONE PARZIALE (FENOMENI DI FRIZIONE, RAMOLLIMENTO, CRISTALLIZZAZIONE)

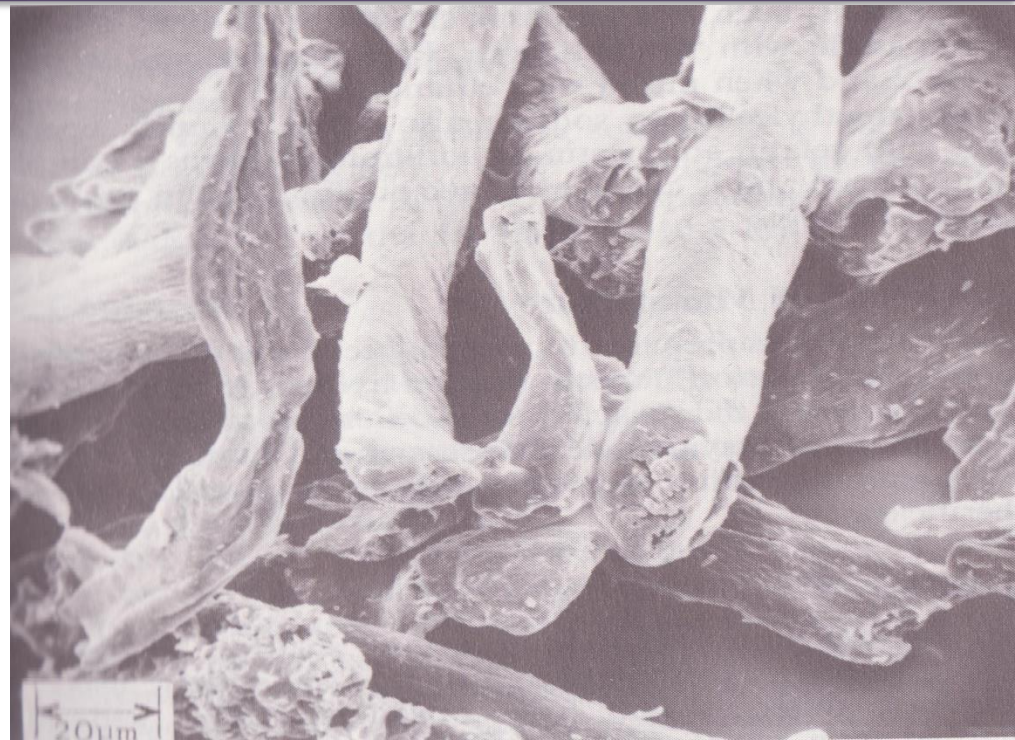
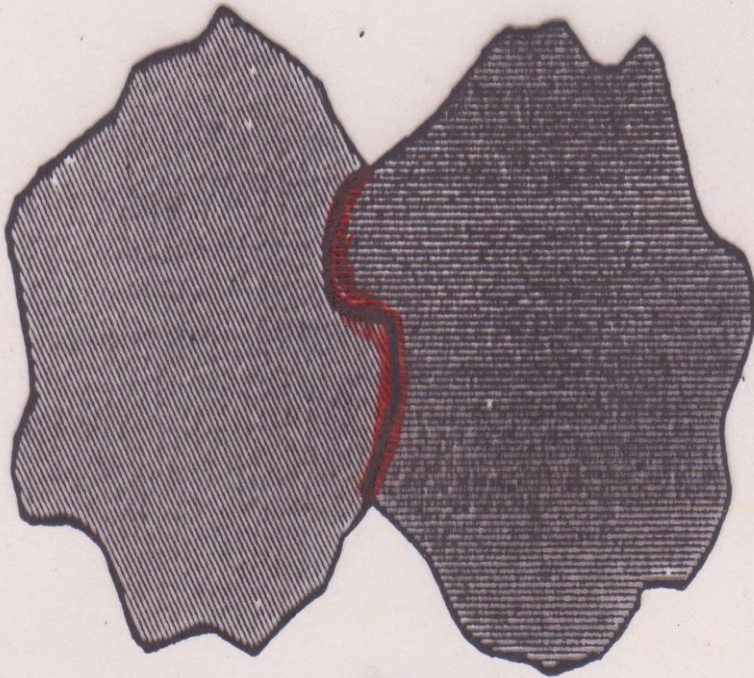

ECCIPIENTI?

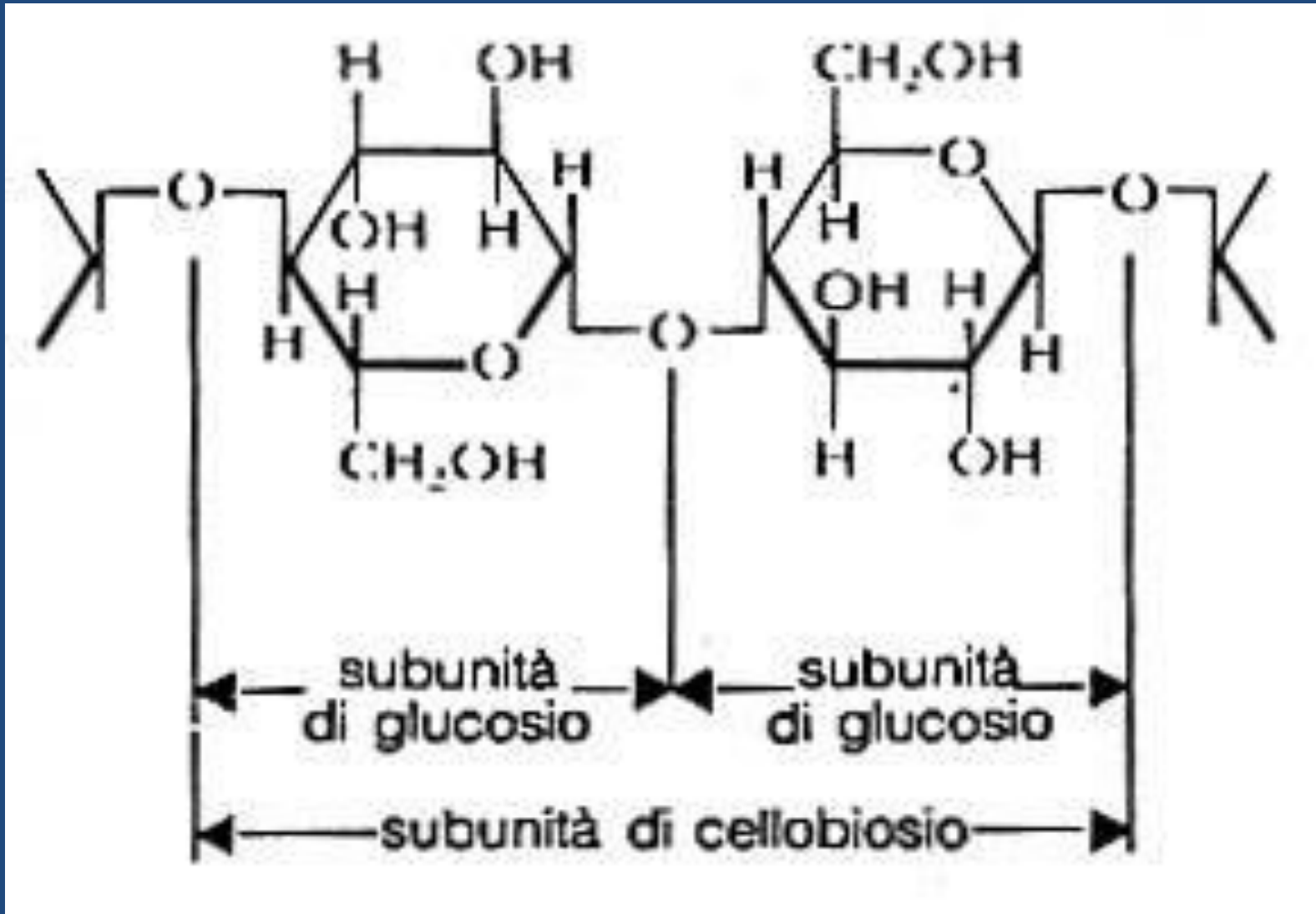

2. GRANULAZIONE AD UMIDO

IMPASTO E GRANULAZIONE ATTRAVERSO RETI

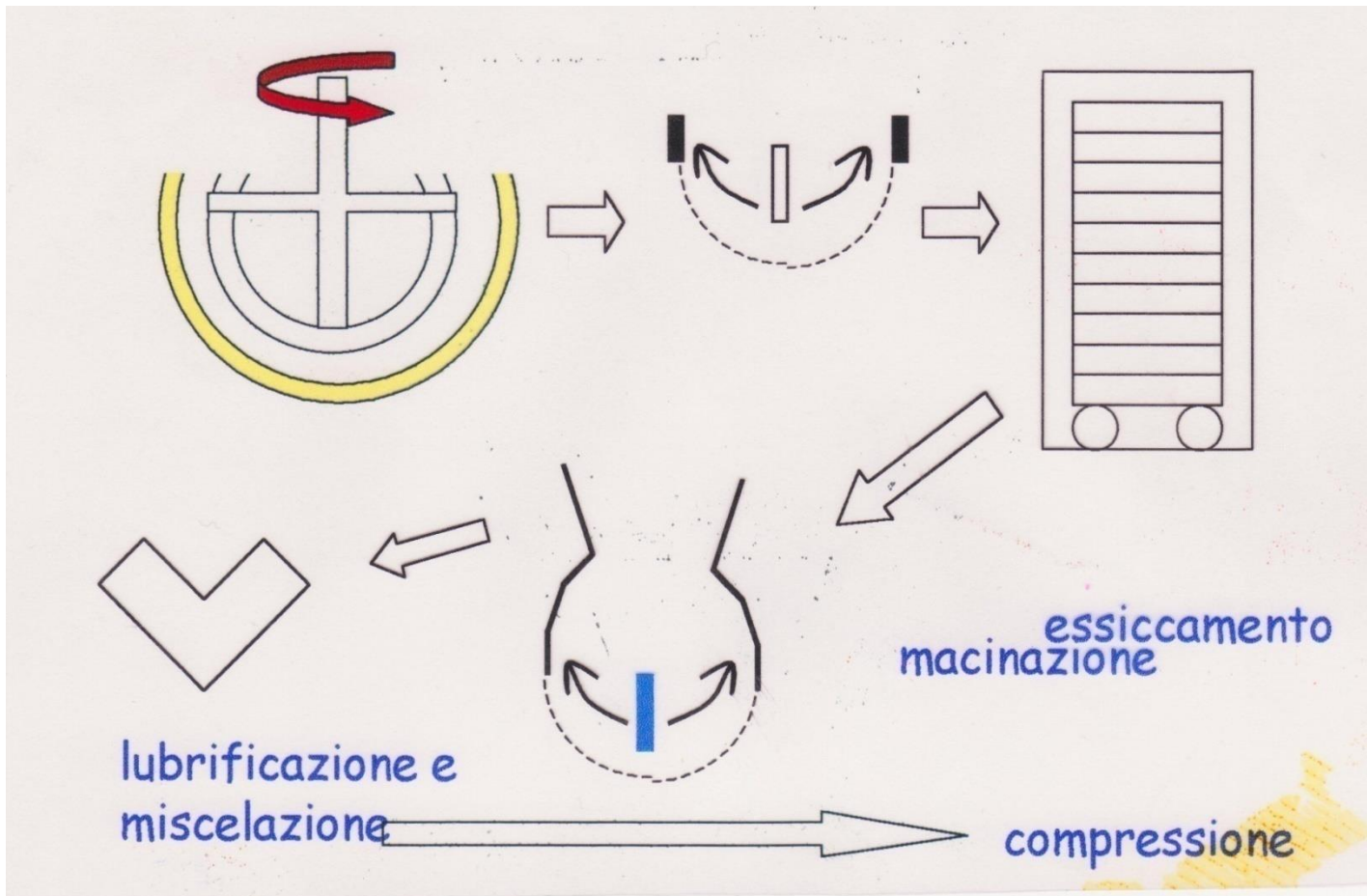

GRANULAZIONE IN LETTO FLUIDO

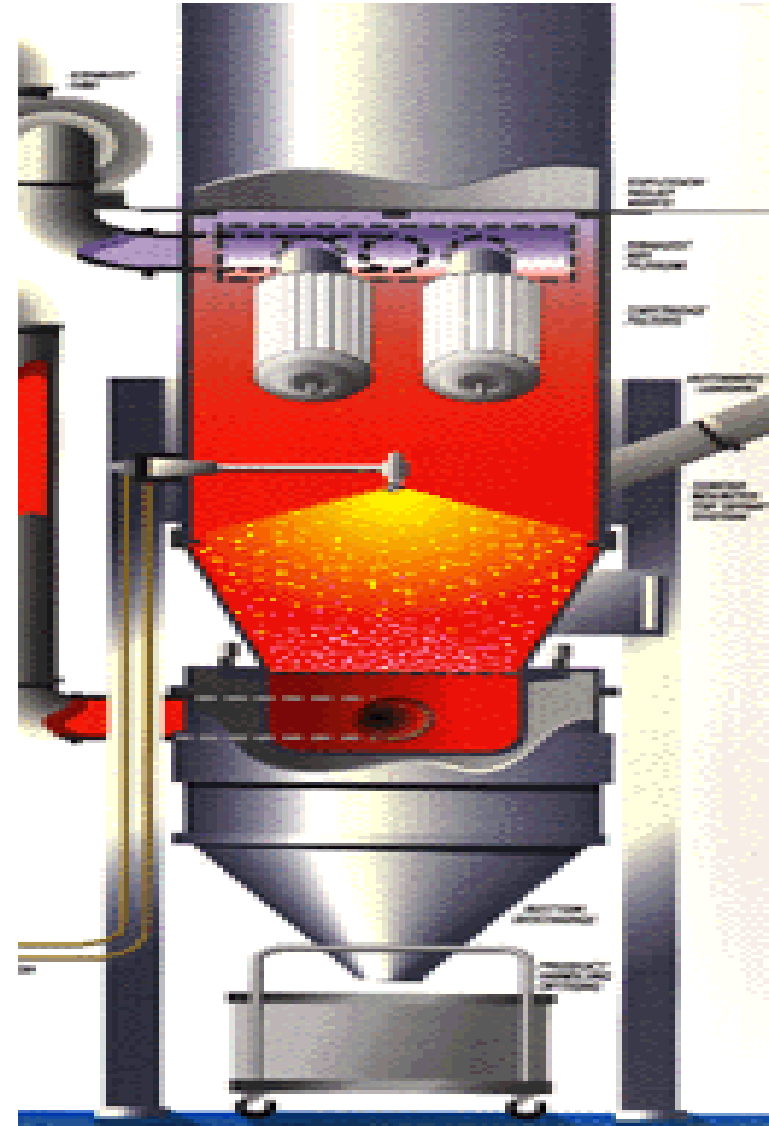
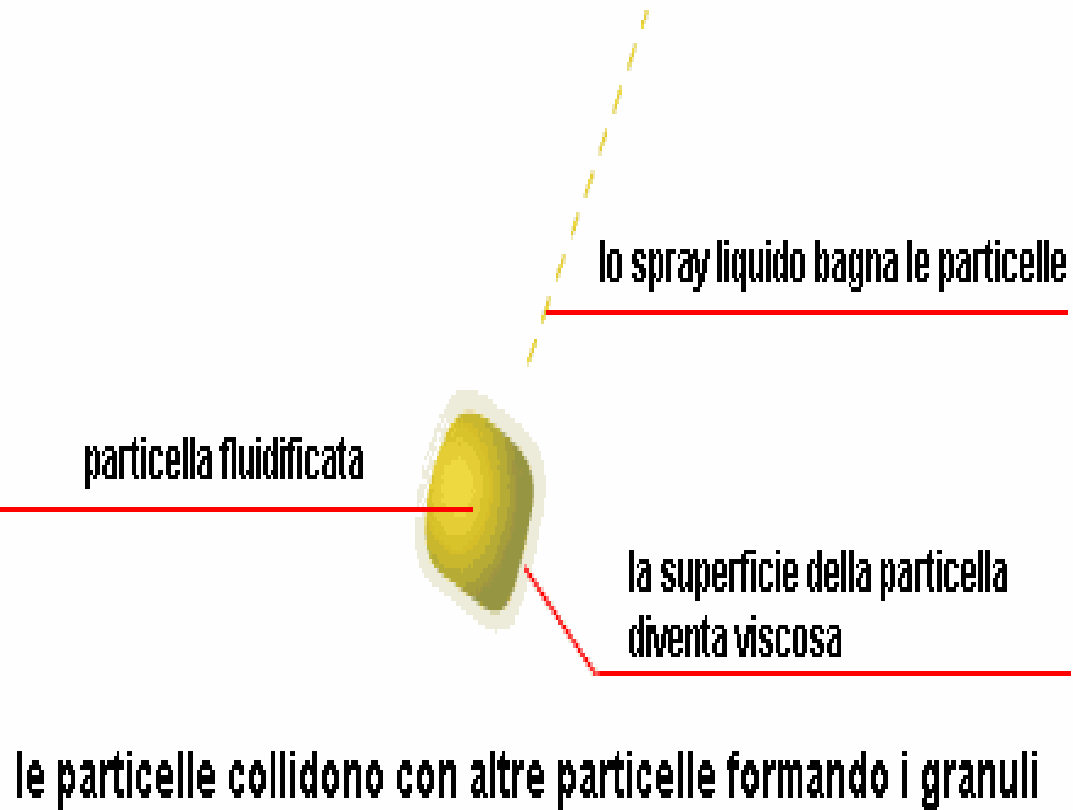

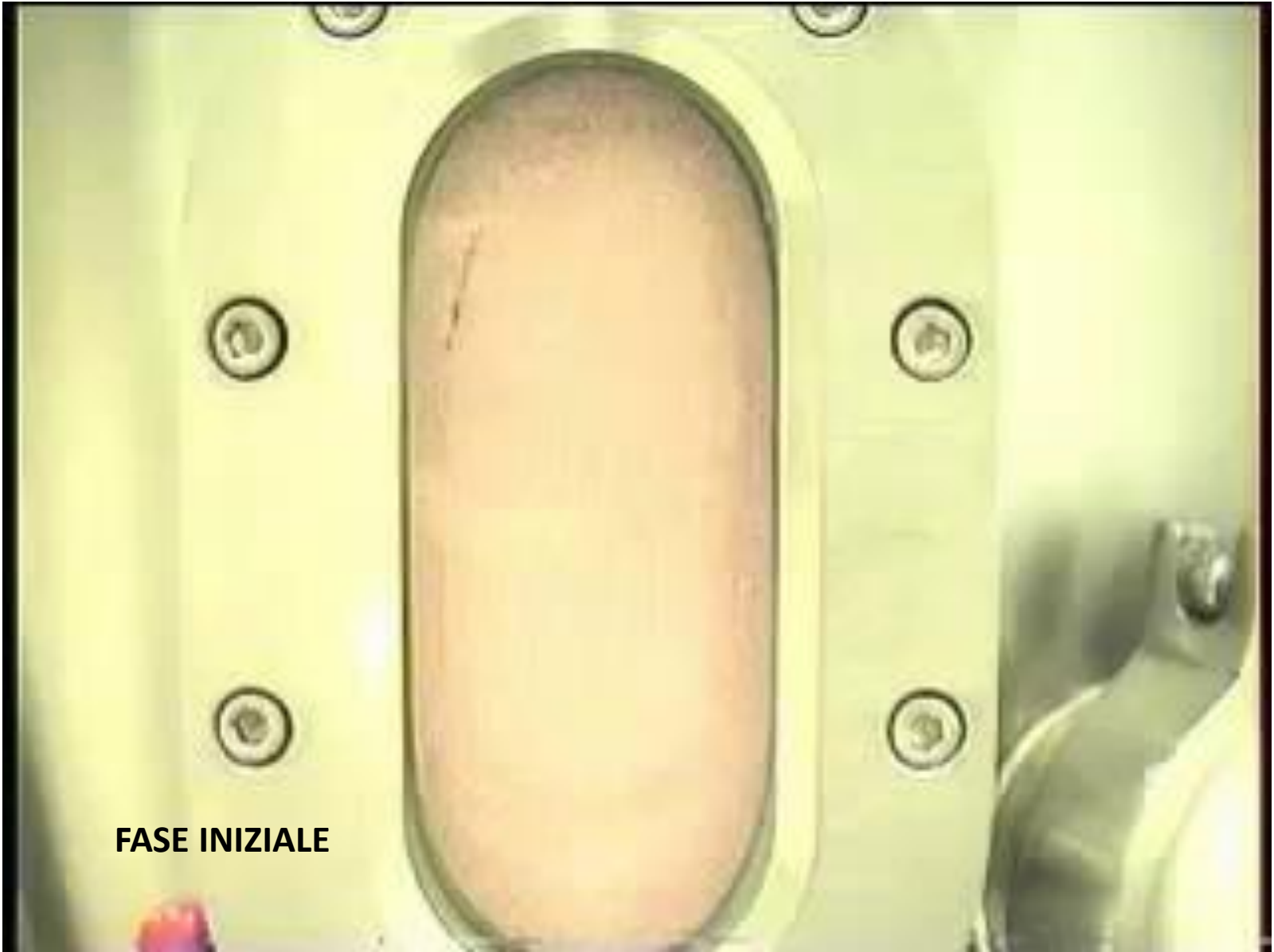

FASE INIZIALE



FASE FINALE

FLUIDISED BED

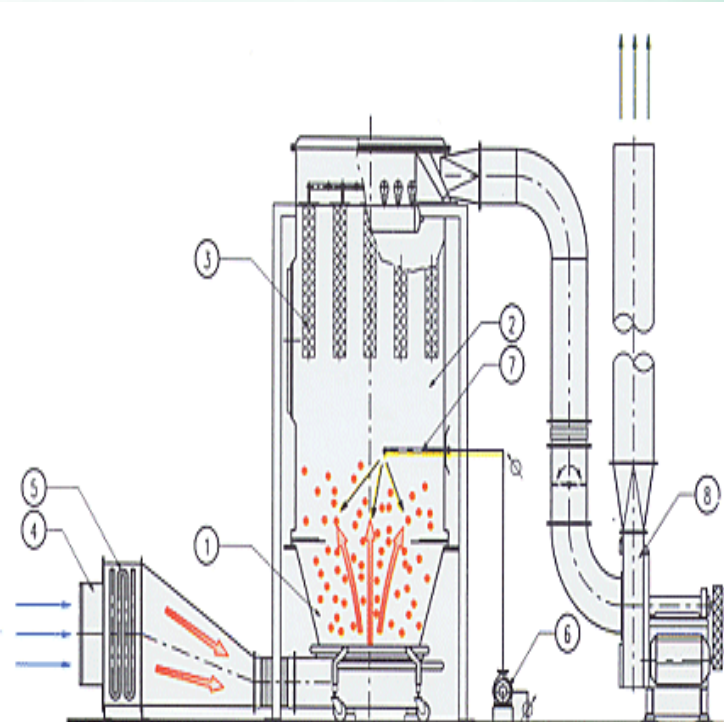

1. Distributor
2. Chamber
3. Filters
4. Inlet air filters
5. Heating system
6. Pump
7. Nozzle
8. Aspirated Fan



Glatt HP process

Glatt process technology





Top Spray process

Glatt process technology



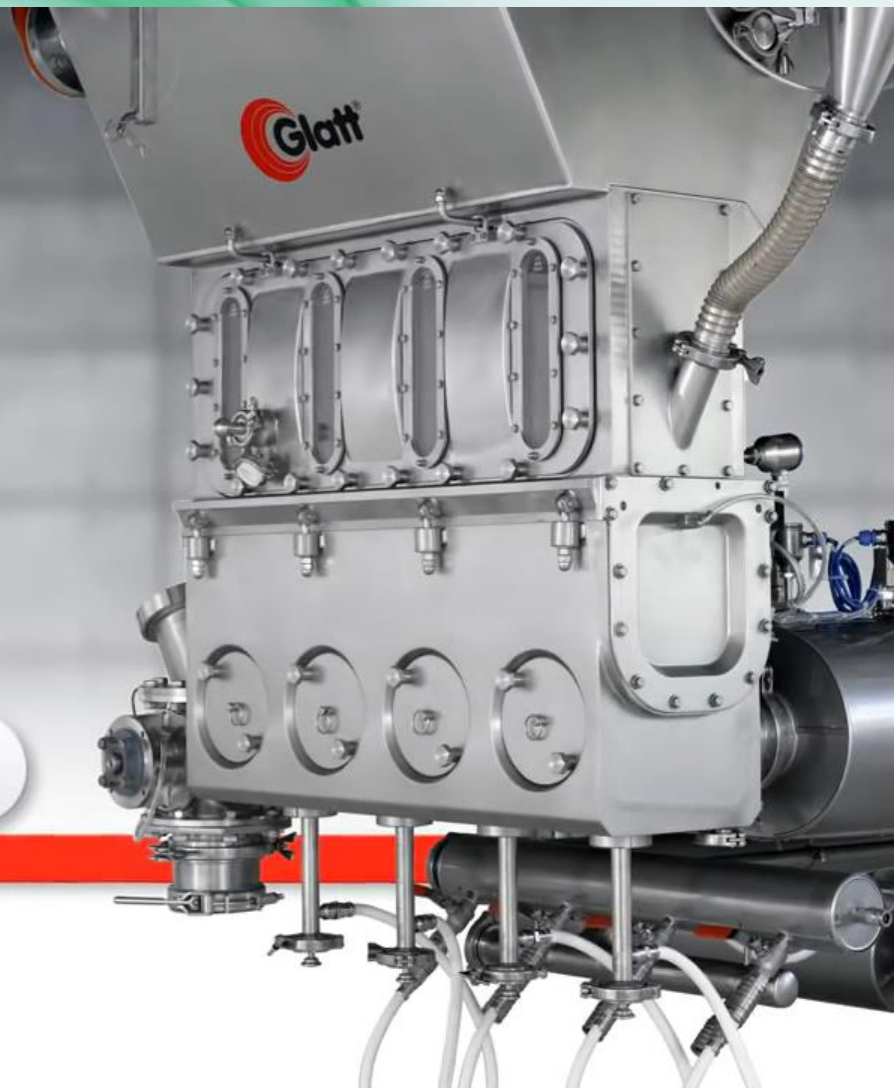

Continuous fluidized bed

Glatt process technology



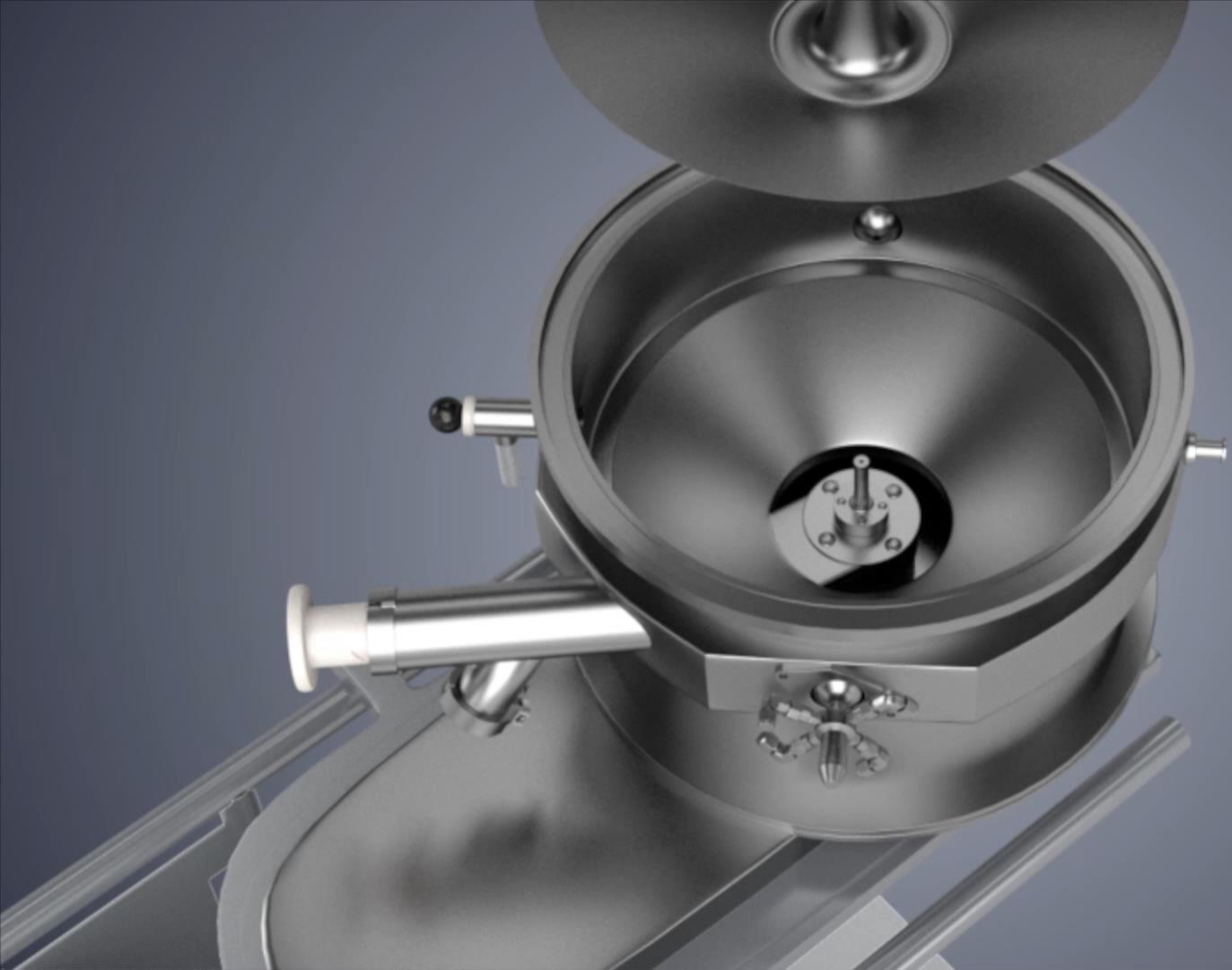



aerbed

CONTENITORE PRODOTTO

Zona
campionatura



IMPIANTI INDUSTRIALI: FLUIDISED BEDS



Scale-up

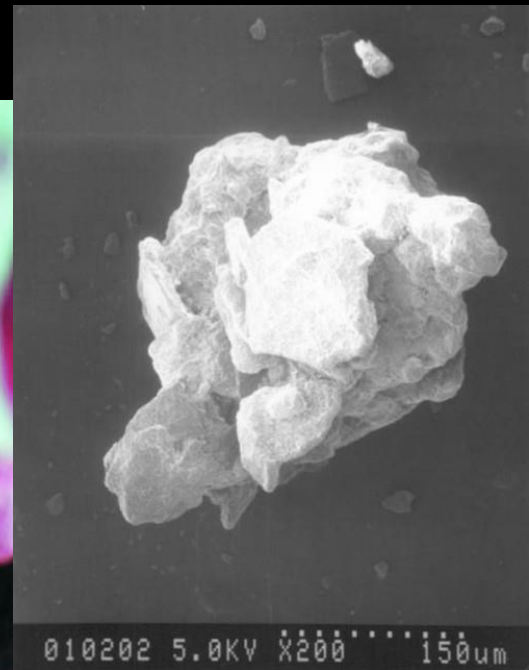
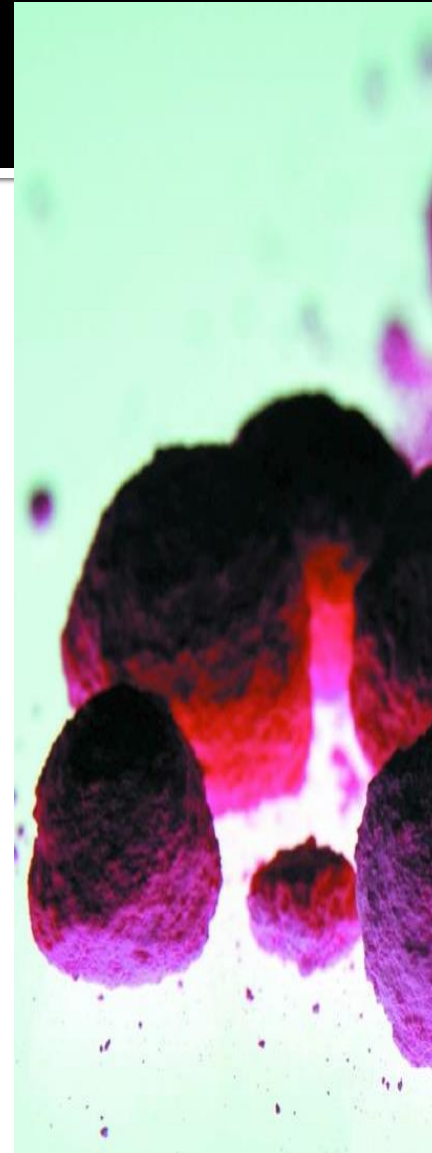
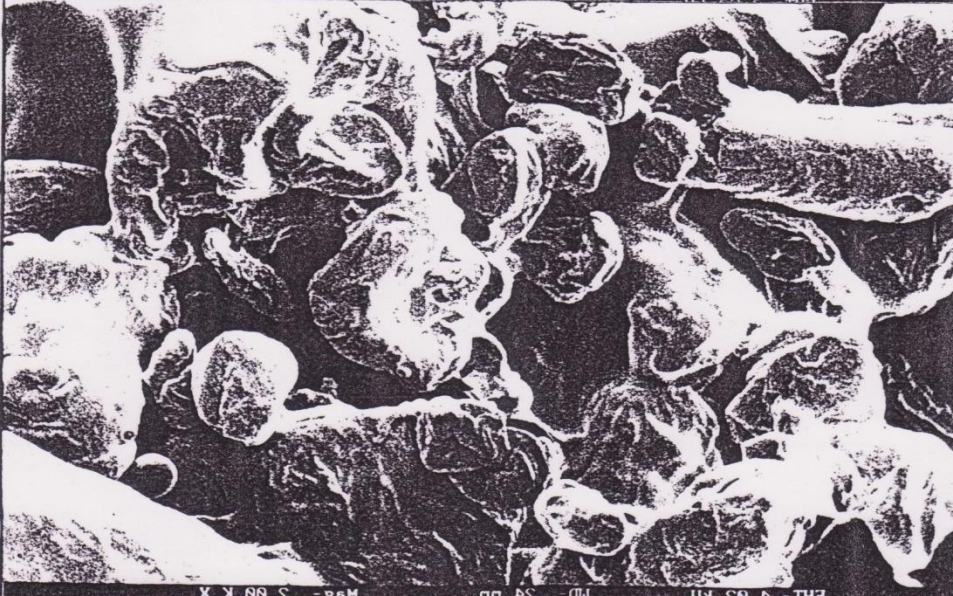
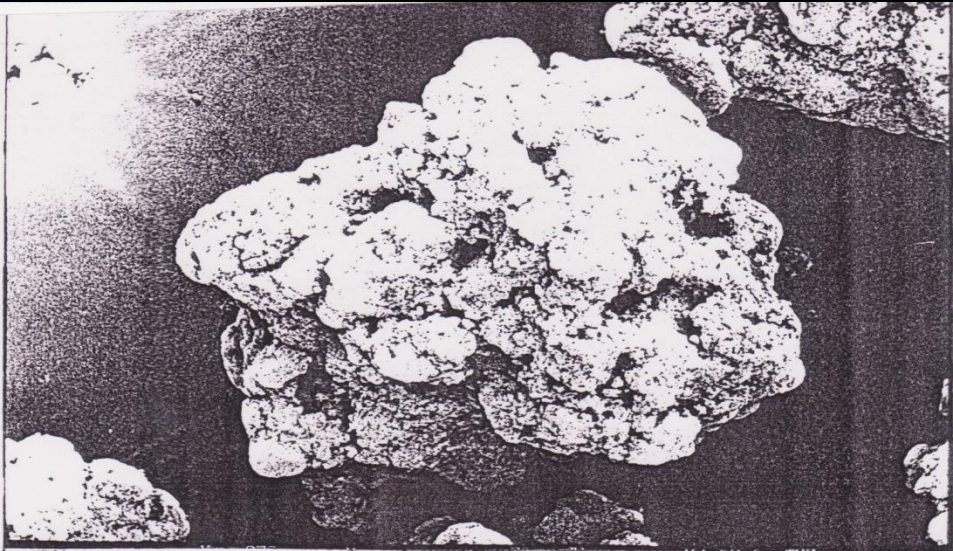

VANTAGGI:

- **NORME DI BUONA FABBRICAZIONE (MISCELAZIONE, GRANULAZIONE, ESSICCAMENTO E RIVESTIMENTO IN UN'UNICA MACCHINA)**
- **TEMPI RIDOTTI**
- **NON SURRISCALDA IL PRODOTTO**
- **RAPIDA EVAPORAZIONE DEI LIQUIDI**
- **GRANULATO POROSO**

SVANTAGGI:

- **DIAMETRO E DISPERSIONE DELLE POLVERI**
- **GRANULATO CON BASSA DENSITÀ APPARENTE**

IMPASTO E GRANULAZIONE IN GRANULATORI RAPIDI

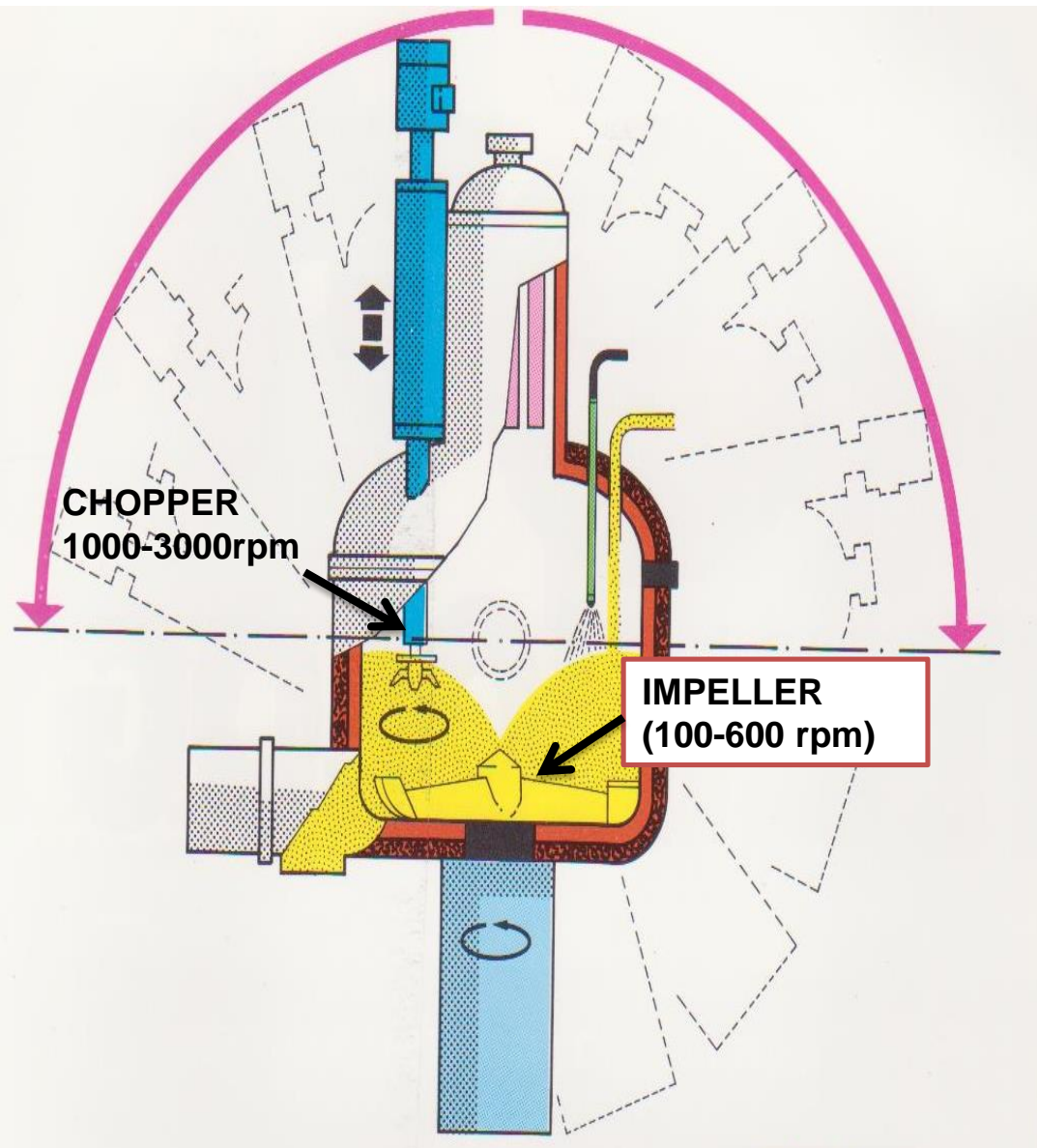

PROCESSO MONOFASICO (NBF):

**MISCELAZIONE →
GRANULAZIONE →
SPRUZZAMENTO
SOLUZIONE LEGANTE →
IMPASTO → FORMAZIONE
DEL GRANULO**



High Shear Granulator

Glatt process technology



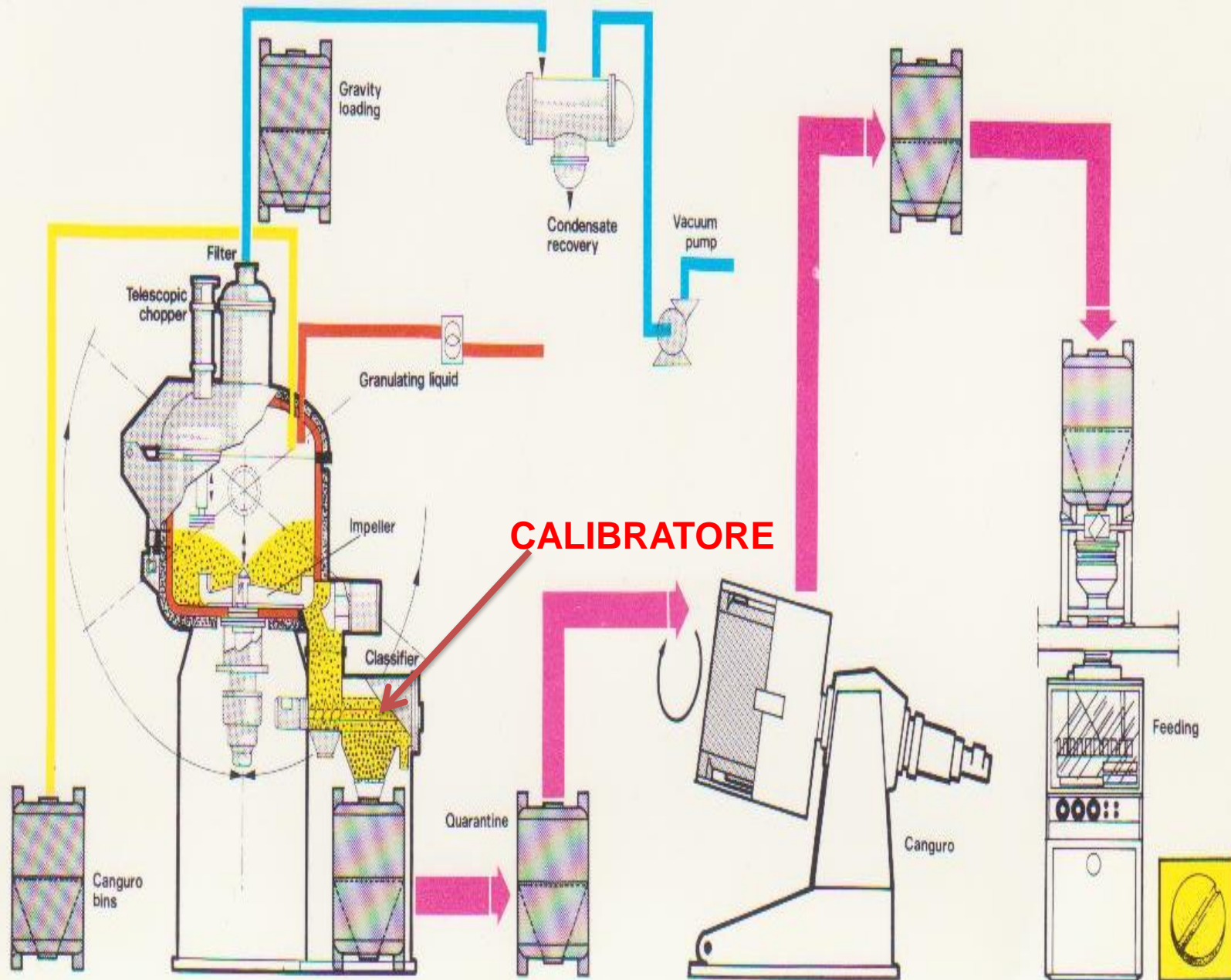

CALIBRATORE

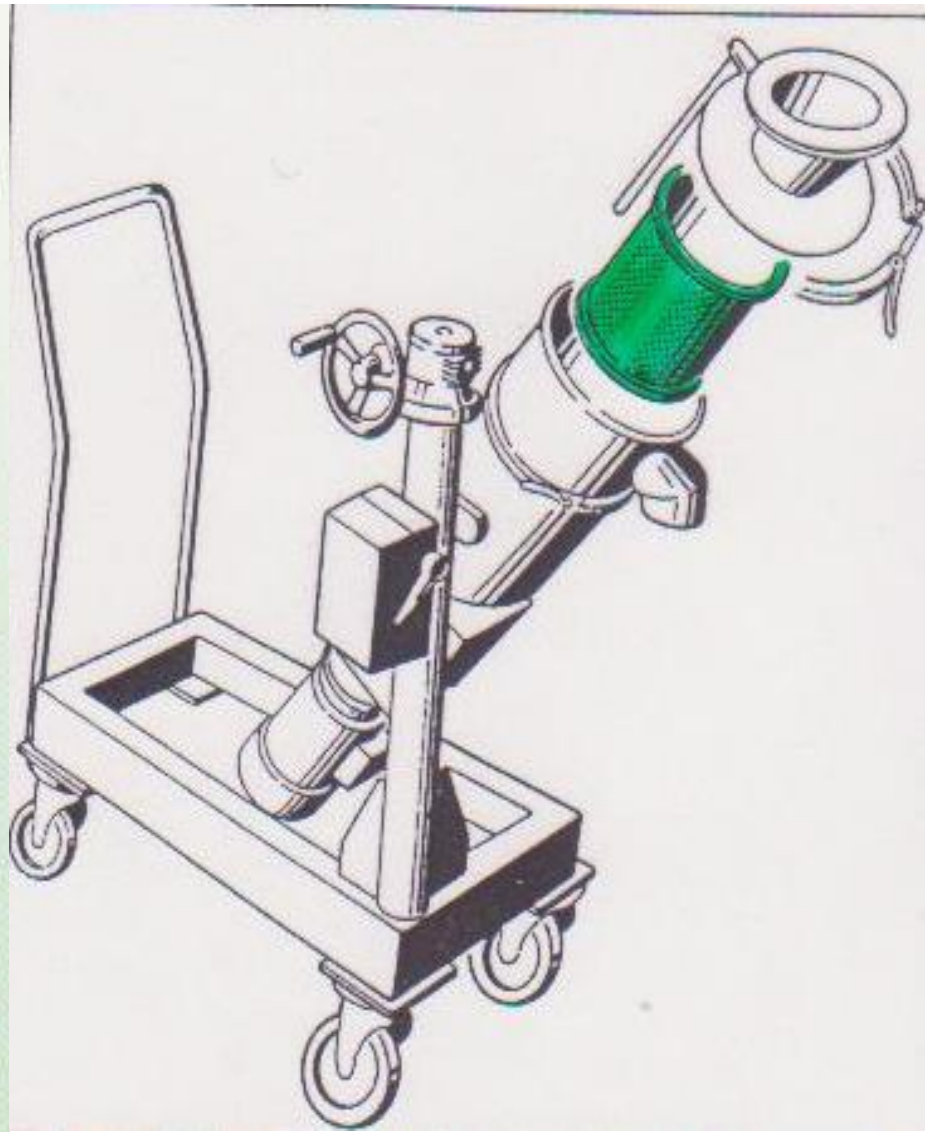
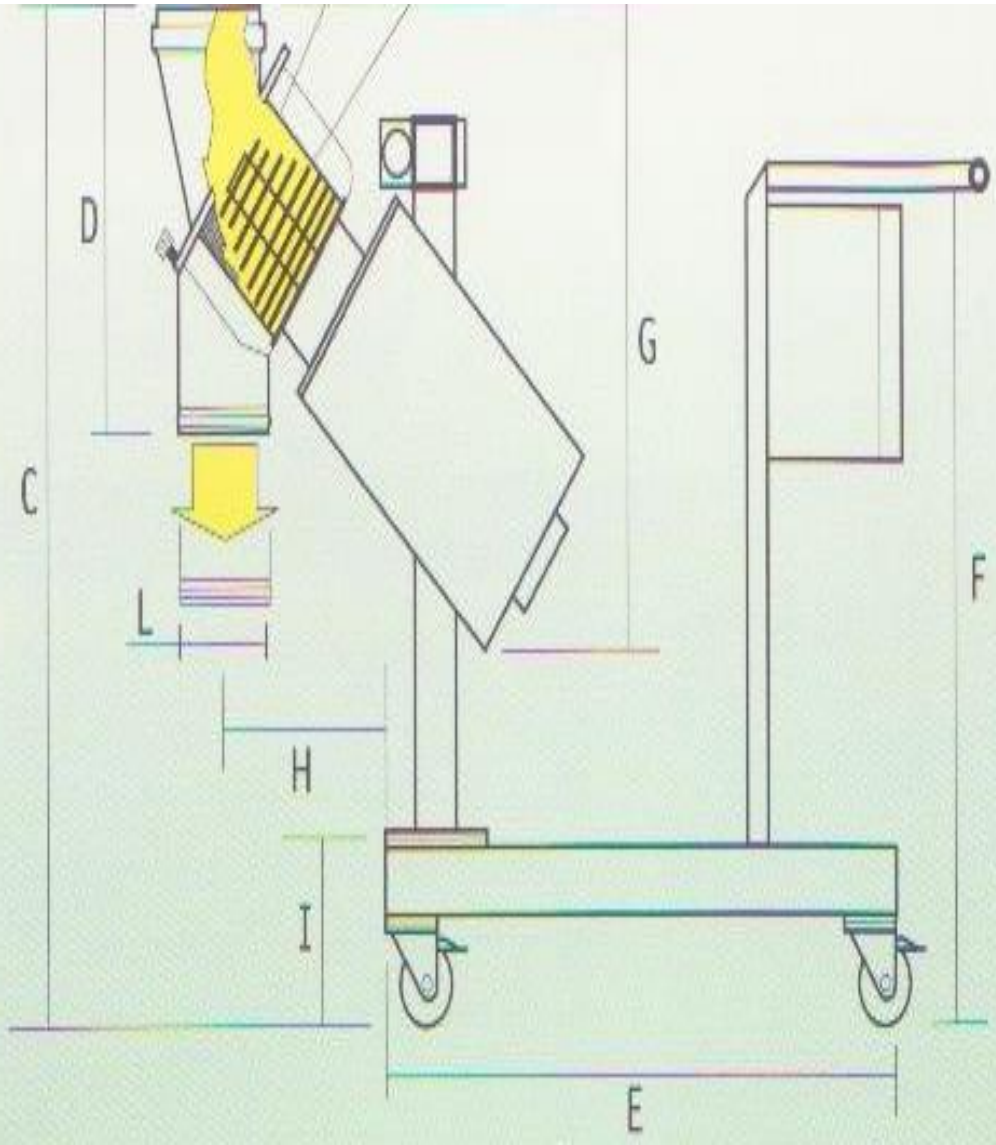



Glatt process technology

MODIFICA MECCANICA

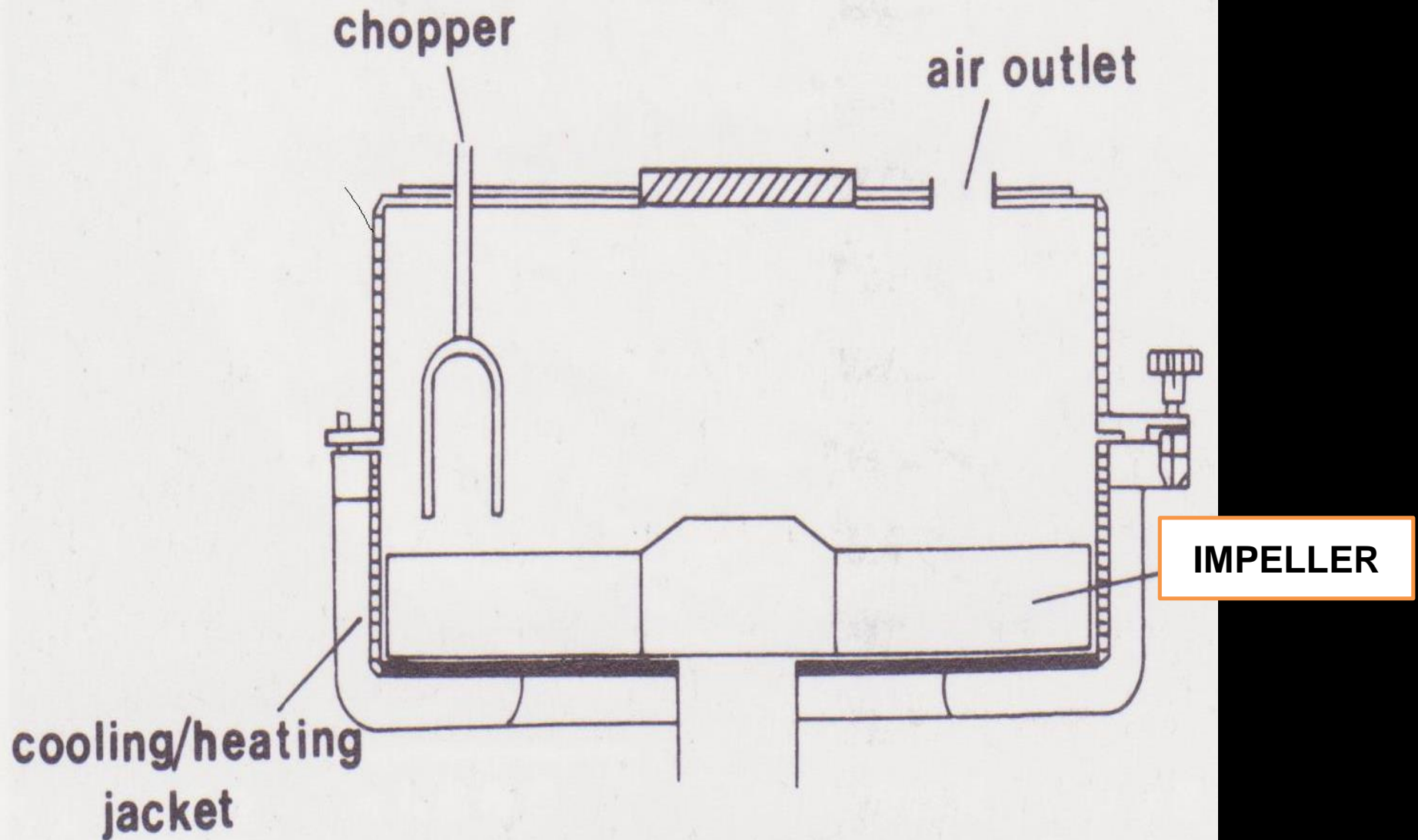

TURBO-SFERA

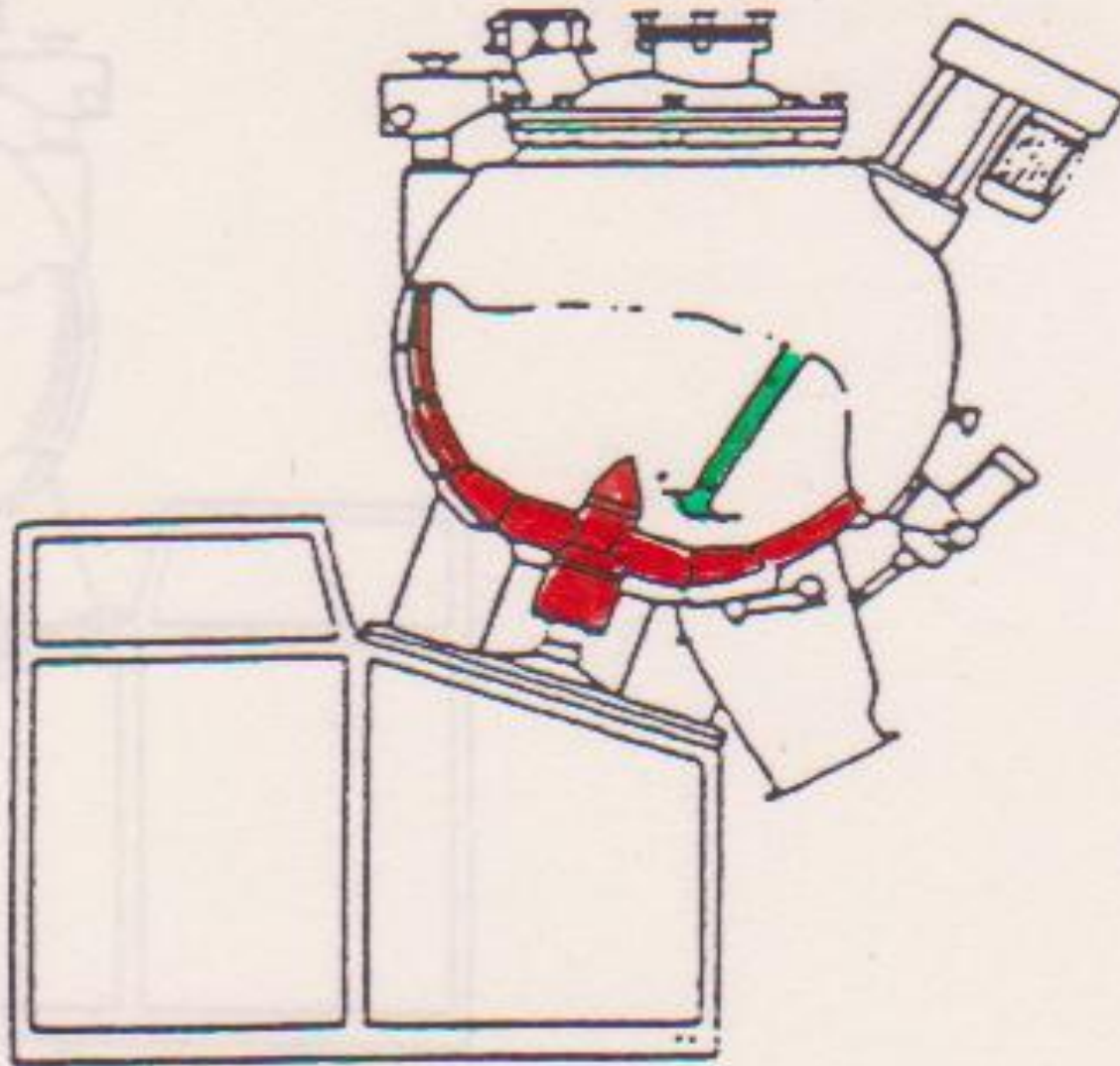

ALTRE MODIFICHE

Top

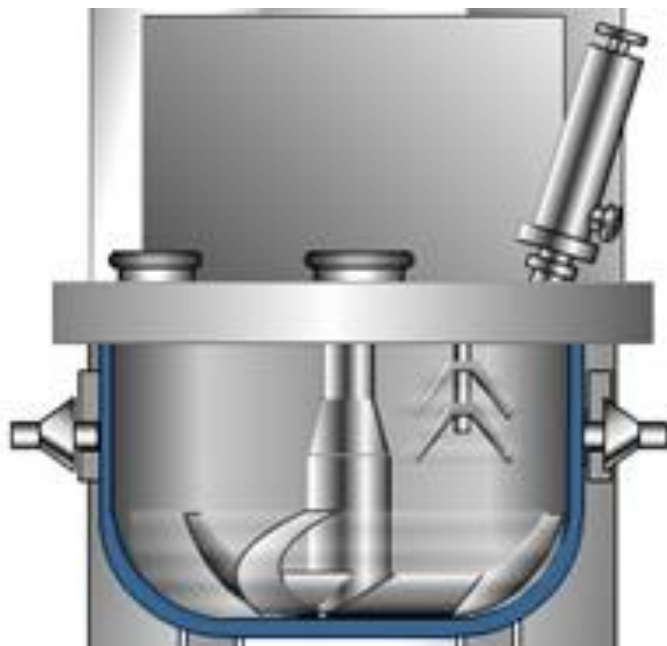

Bottom



GRANULO NON POROSO (COMPATTO)

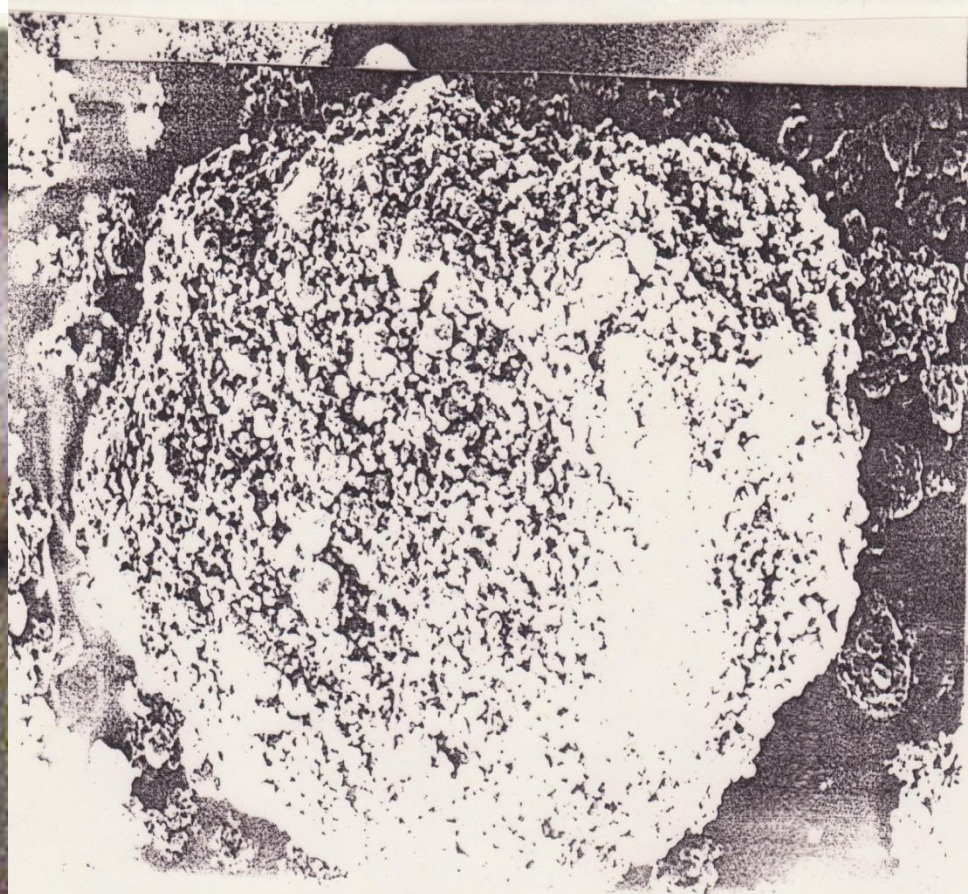

GRANULO NON POROSO – COMPATTO – CON DIVERSA MORFOLOGIA

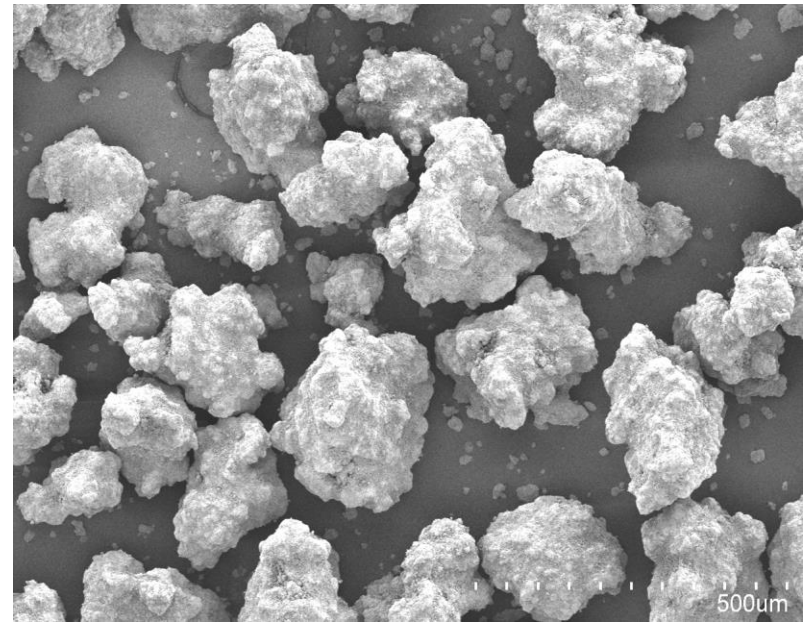
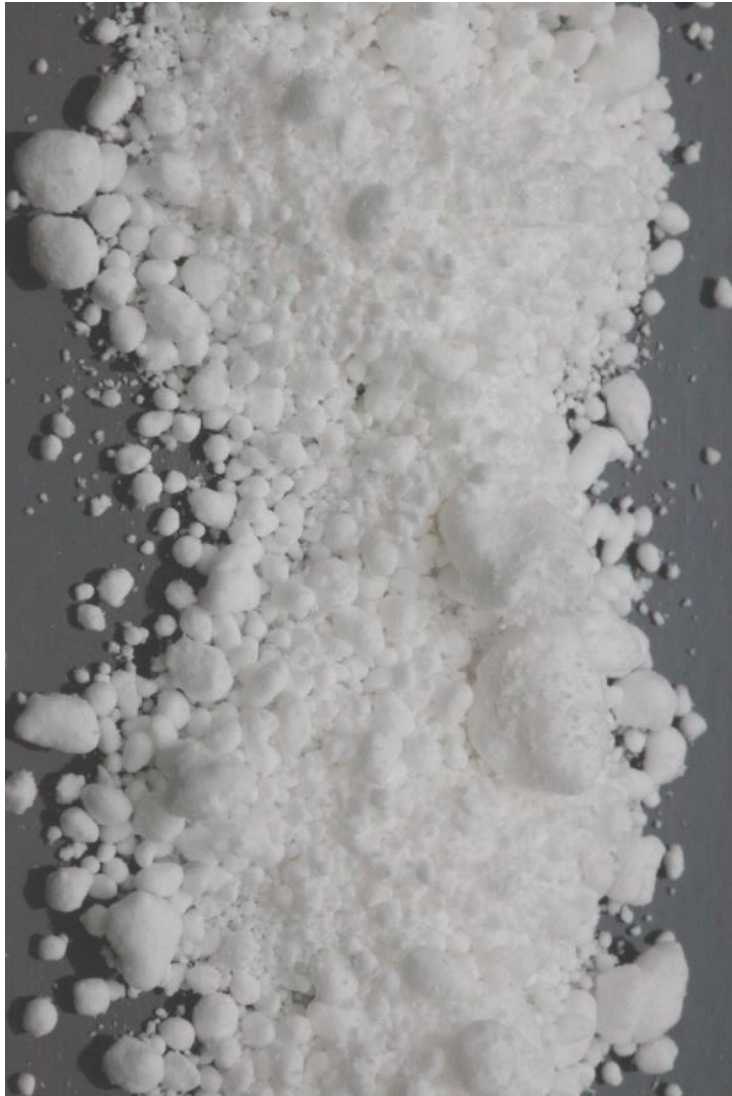

DIFFICOLTÀ DI MESSA A PUNTO:

- 1. DIFFICOLTÀ NELL'OTTENIMENTO DEL GRANULO UMIDO (SCARSA CAPACITÀ LEGANTE)**
- 2. DIFFICOLTÀ NEL MANTENIMENTO DEL GRANULO IN FASE DI ESSICCAMENTO (SCARSA CAPACITÀ LEGANTE)**
- 3. OTTENIMENTO DI GRANULI DI DIMENSIONI TROPPO ELEVATE (CAPACITÀ LEGANTI ECCESSIVE)**
- 4. DIFFICOLTÀ DI ESSICCAMENTO**

EFFETTO BAGNATURA-VELOCITA' - I

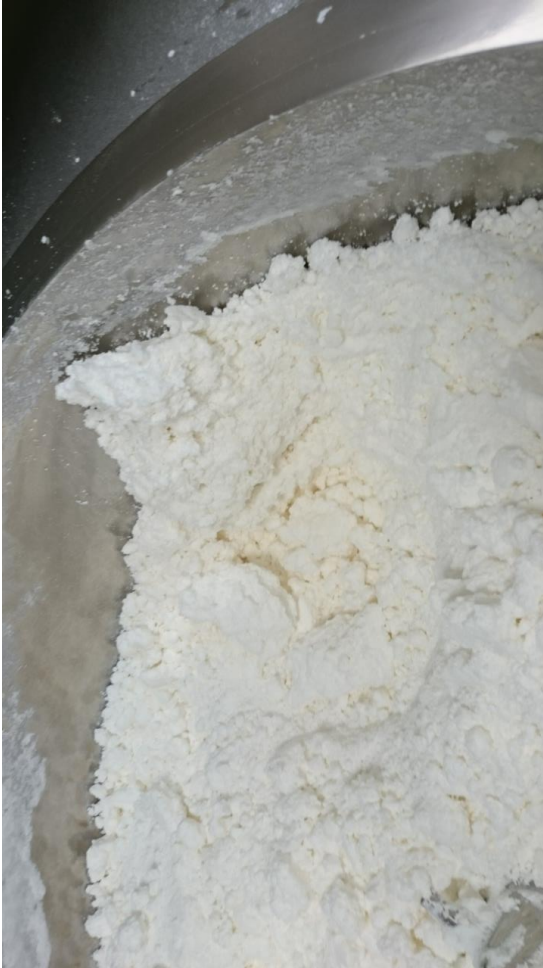

EFFETTO BAGNATURA-VELOCITA' - II

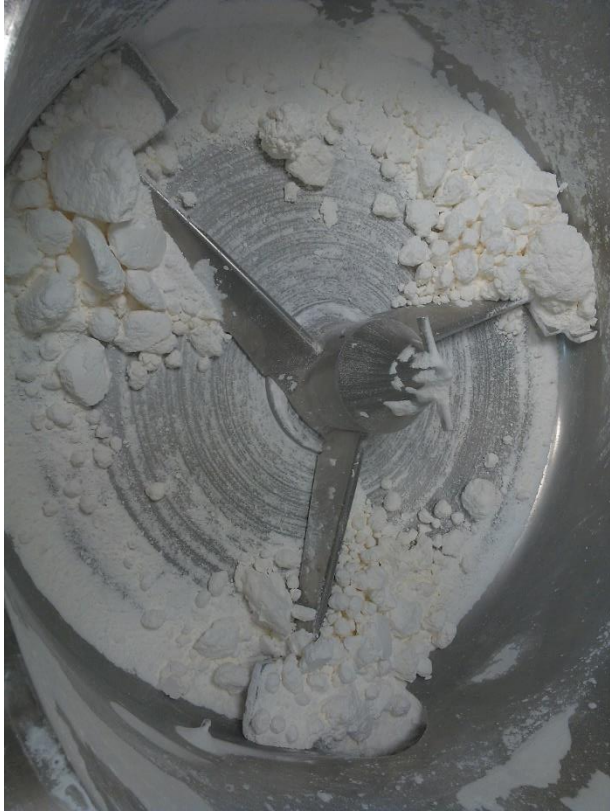

MECCANISMO DI LEGAME:

1. FORZE DI ADESIONE E COESIONE IN FILM LIQUIDI
2. PONTI SOLIDI PER INDURIMENTO DI LEGANTI O PER CRISTALLIZZAZIONE DI SOSTANZE DISCIOLTE

PONTI SOLIDI

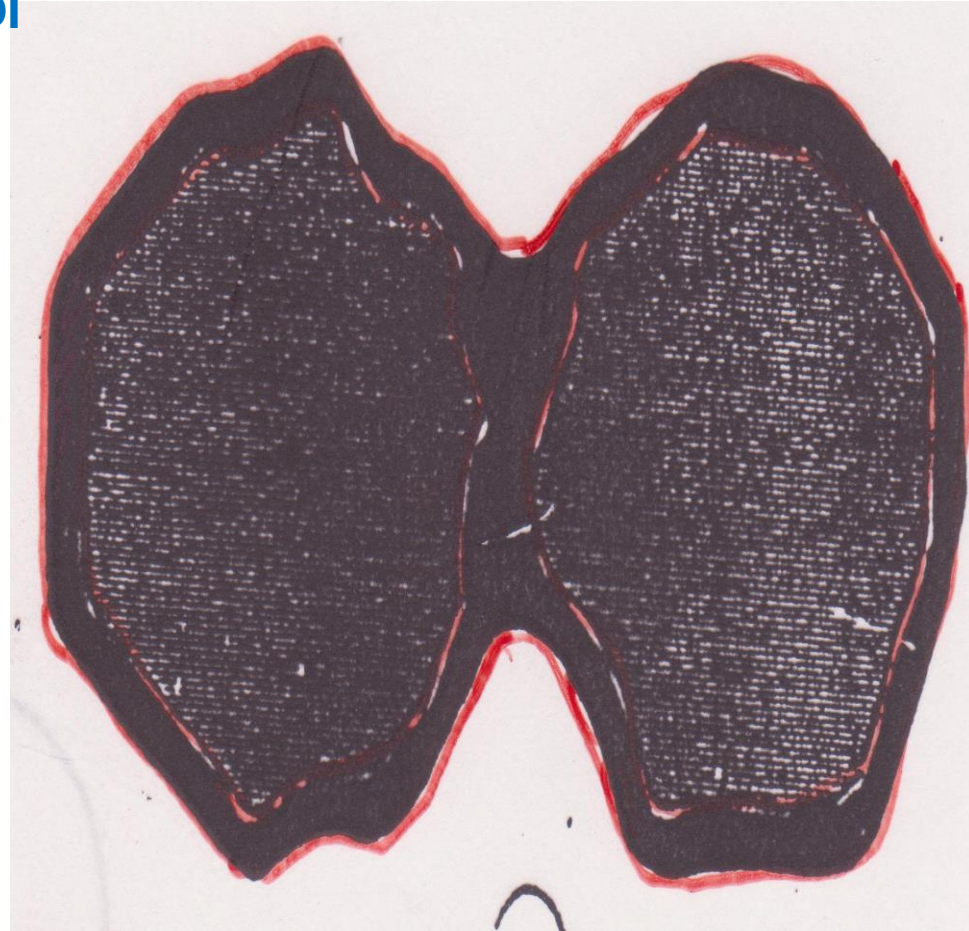
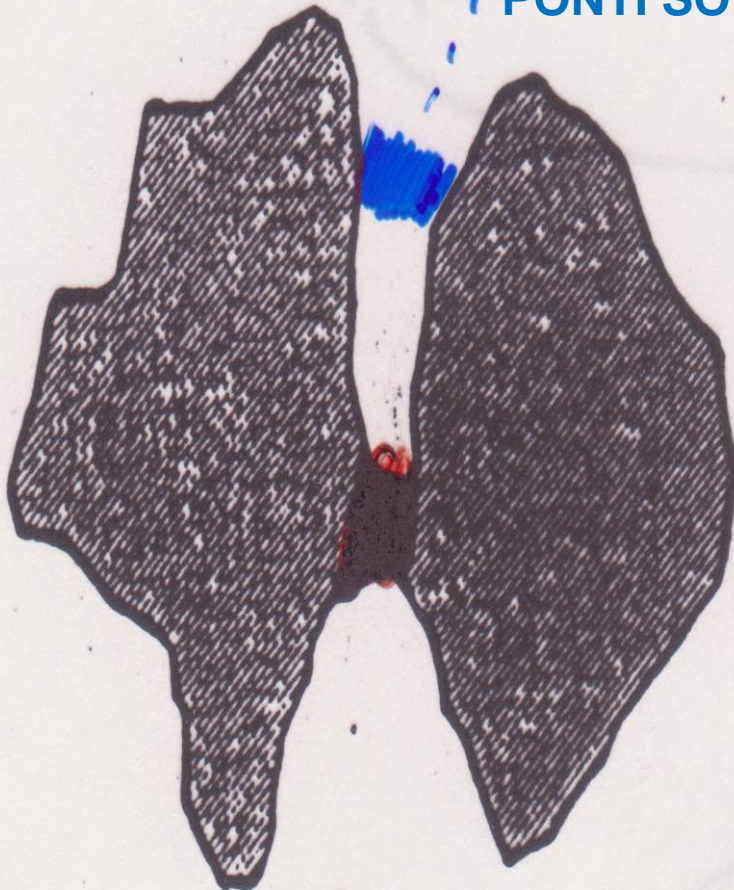





P/Q-GRANULAZIONE



IMPELLER

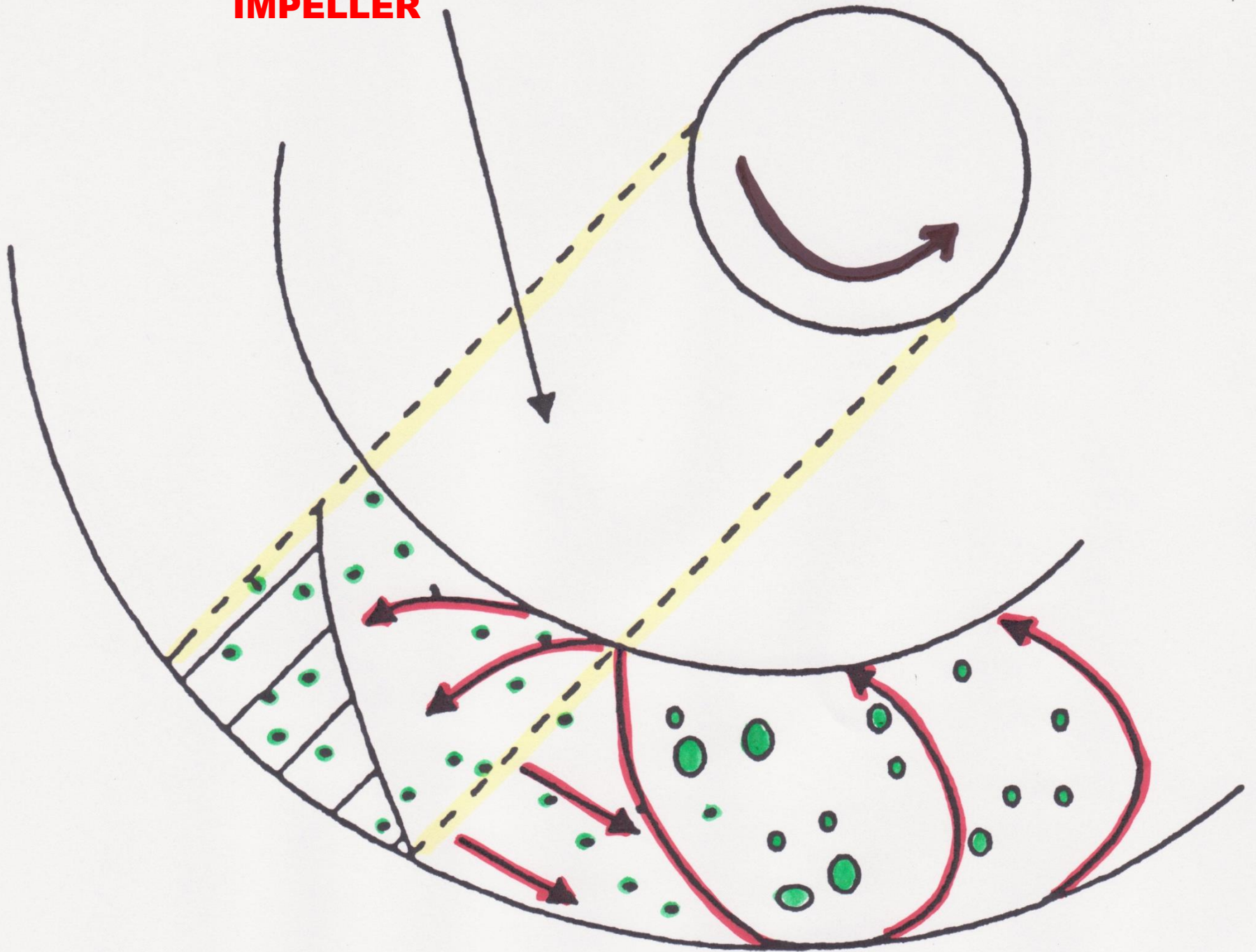

MECCANISMO DI RIDUZIONE DELLE DIMENSIONI:

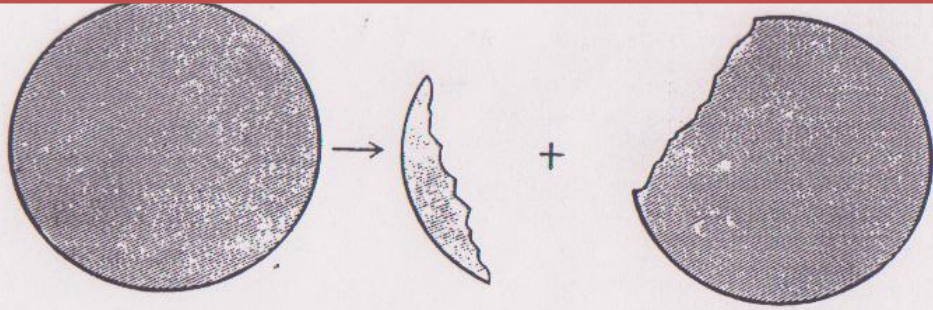

ROTTURA

FRANTUMAZIONE

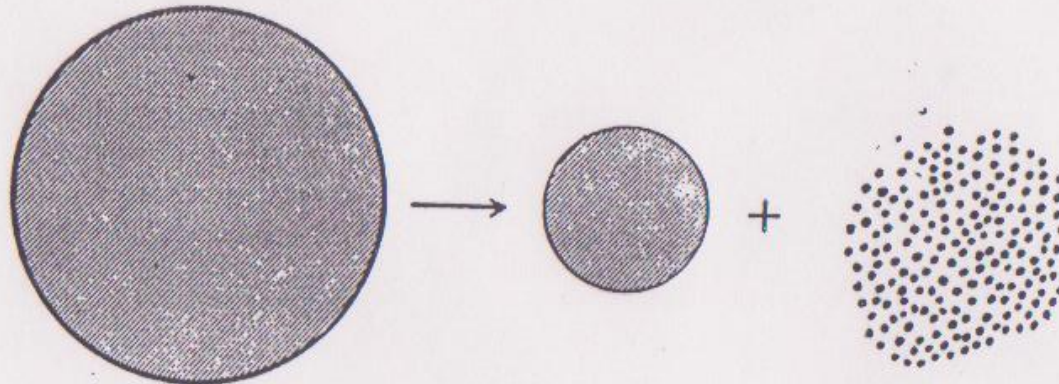
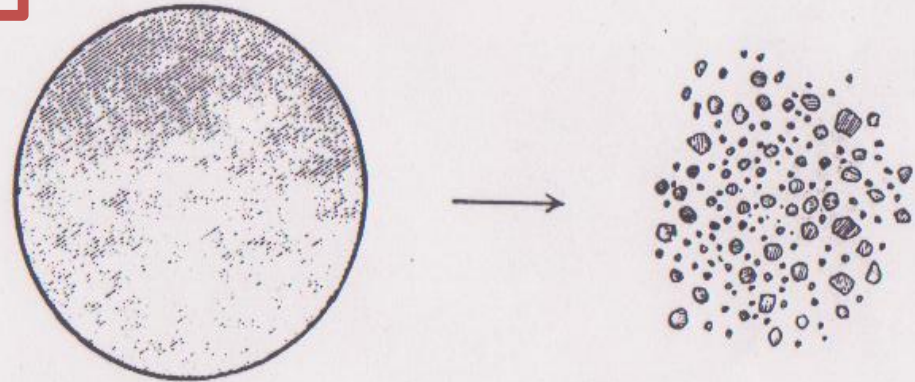

ATTRITO

MECCANISMI DI INGROSSAMENTO:



NUCLEAZIONE



COALESCENZA

STRATIFICAZIONE

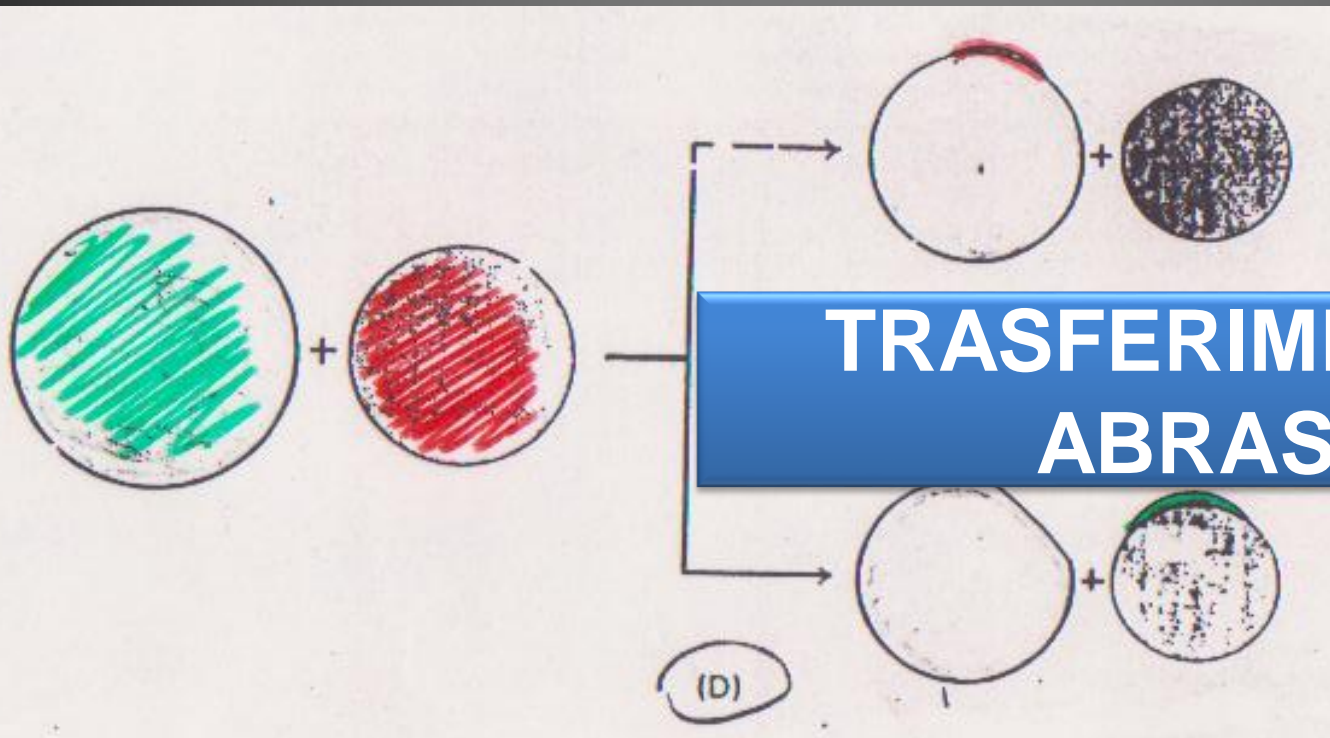
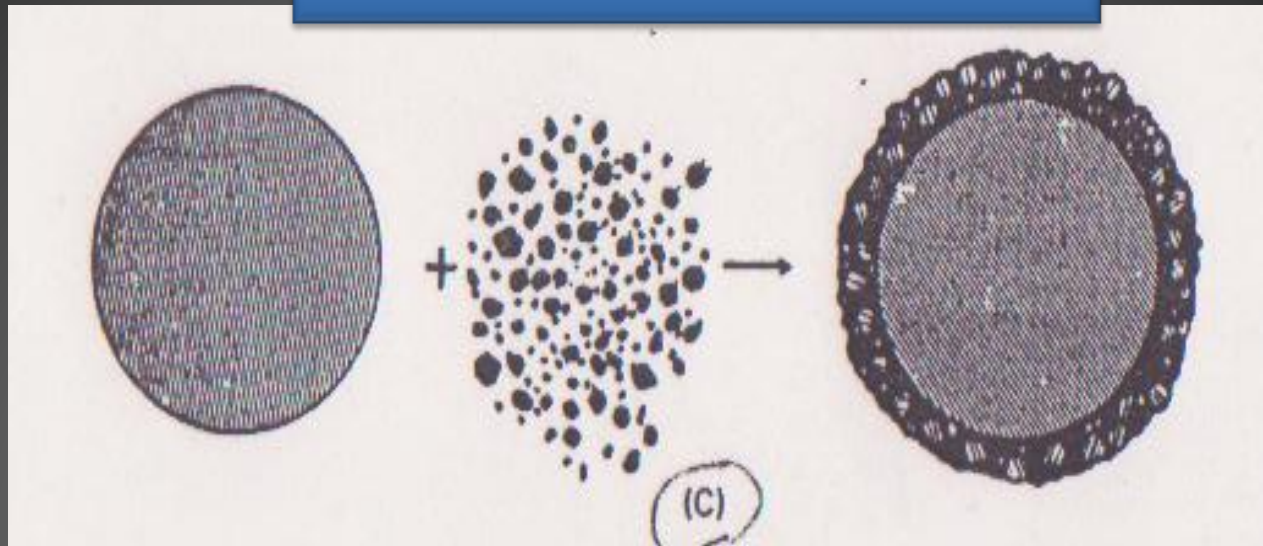

TRASFERIMENTO PER
ABRASIONE

PARAMETRI DI PROCESSO:

1. MISCELAZIONE DELLE POLVERI : t = 5-10 minuti

$$V_p = V_r * D * \pi / 60$$

DOVE:

V_p = VELOCITÀ PERIFERICA (m/sec)

V_r = VELOCITÀ DI ROTAZIONE DELL'IMPELLER (rpm)

D = DIAMETRO DELL'AGITATORE (m)



superficie toroidale

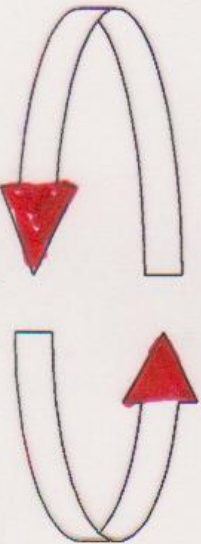



impeller



telescopic chopper

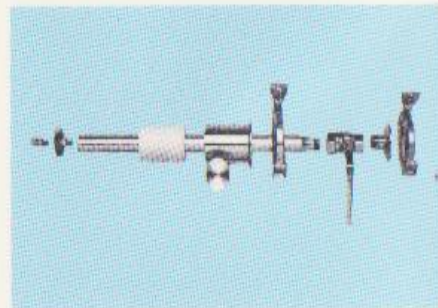

spraying system

mixing 0,5-1-2-4 sec.

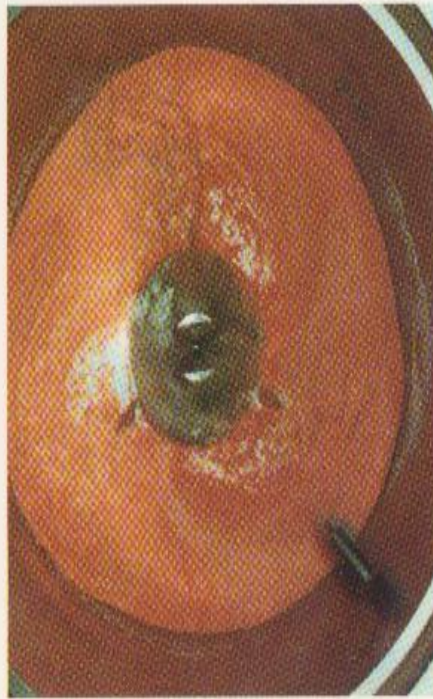



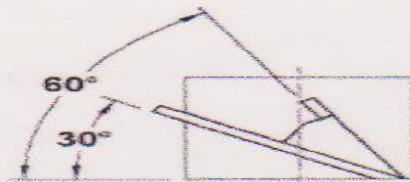
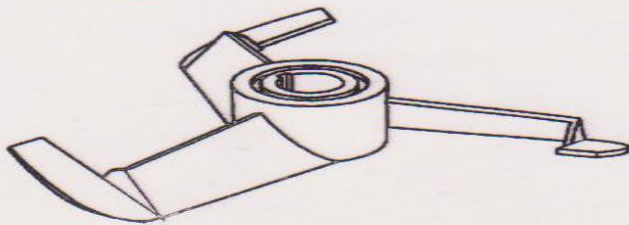
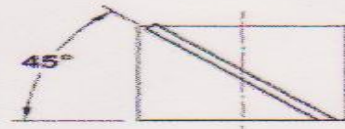
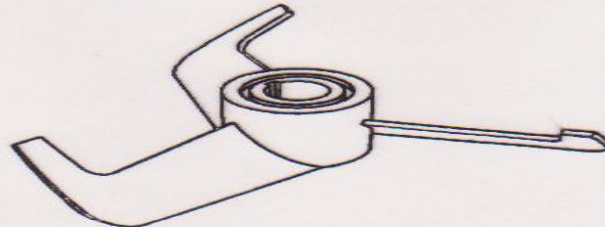
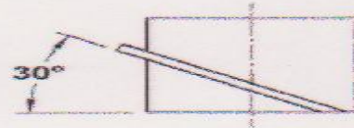
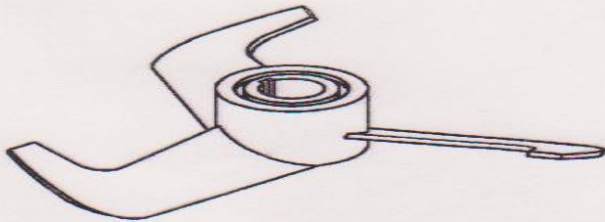
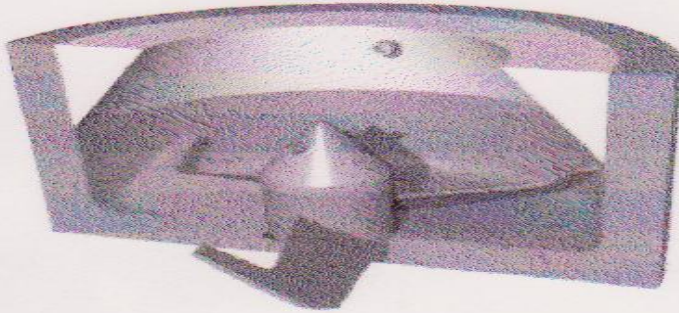

2. QUANTITÀ DI SOLUZIONE LEGANTE

INFLUENZA: DIMENSIONI, DUREZZA E TEMPO D'ESSICCAMENTO.

Quantità di H₂O

-miscela a base zuccherina (saccarosio) 2 - 5%

-lattosio+ amidi 15 - 30%

-idrossidi metallici (Al,Mg,etc) 10-15%

-Mannitolo e similari 25 - 30 %

-cellulosa microcristallina 90 - 100 %

UMIDITÀ INIZIALE: (kg DI H₂O/kg DI POLVERE SECICHE)*100

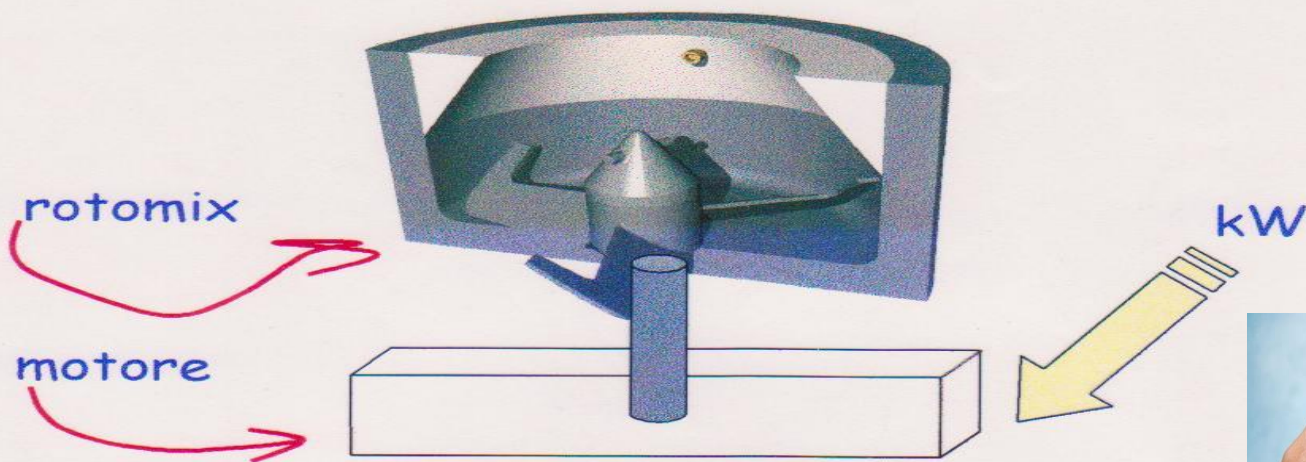

pendolare funicolare capillare goccia

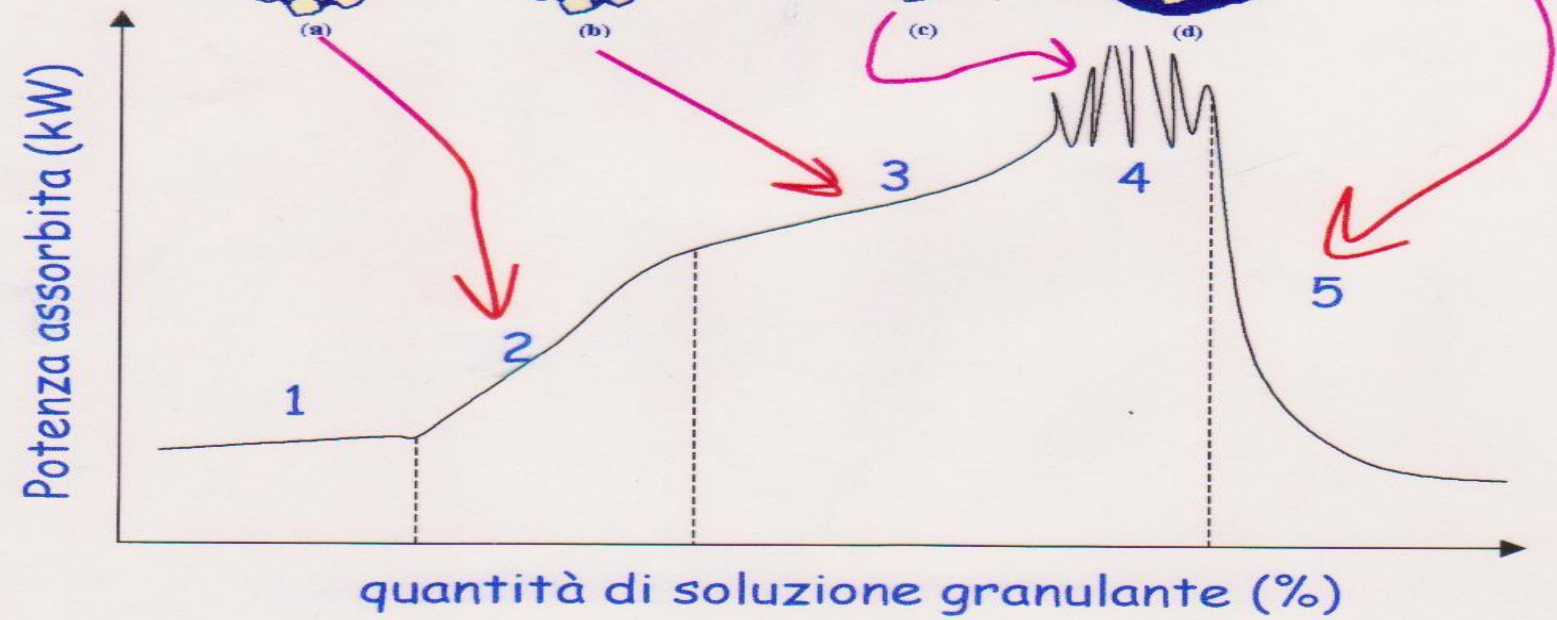
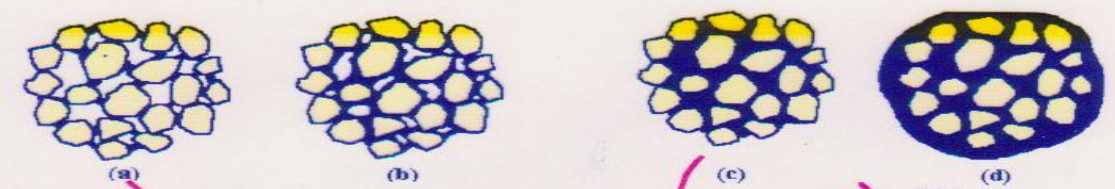

Pendolare

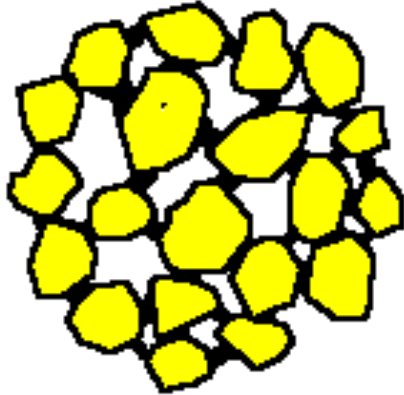

(a)

Funicolare

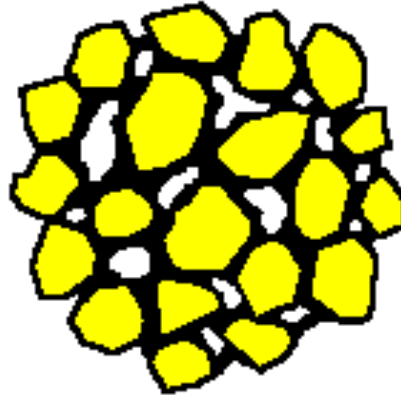

(b)



(c)

Capillare

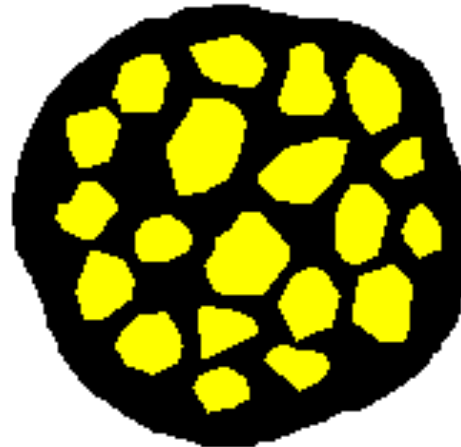

(d)

Goccia

- aria
- liquido
- solido

ASSORBIMENTO DI POTENZA (BAGNATURA OTTIMALE)

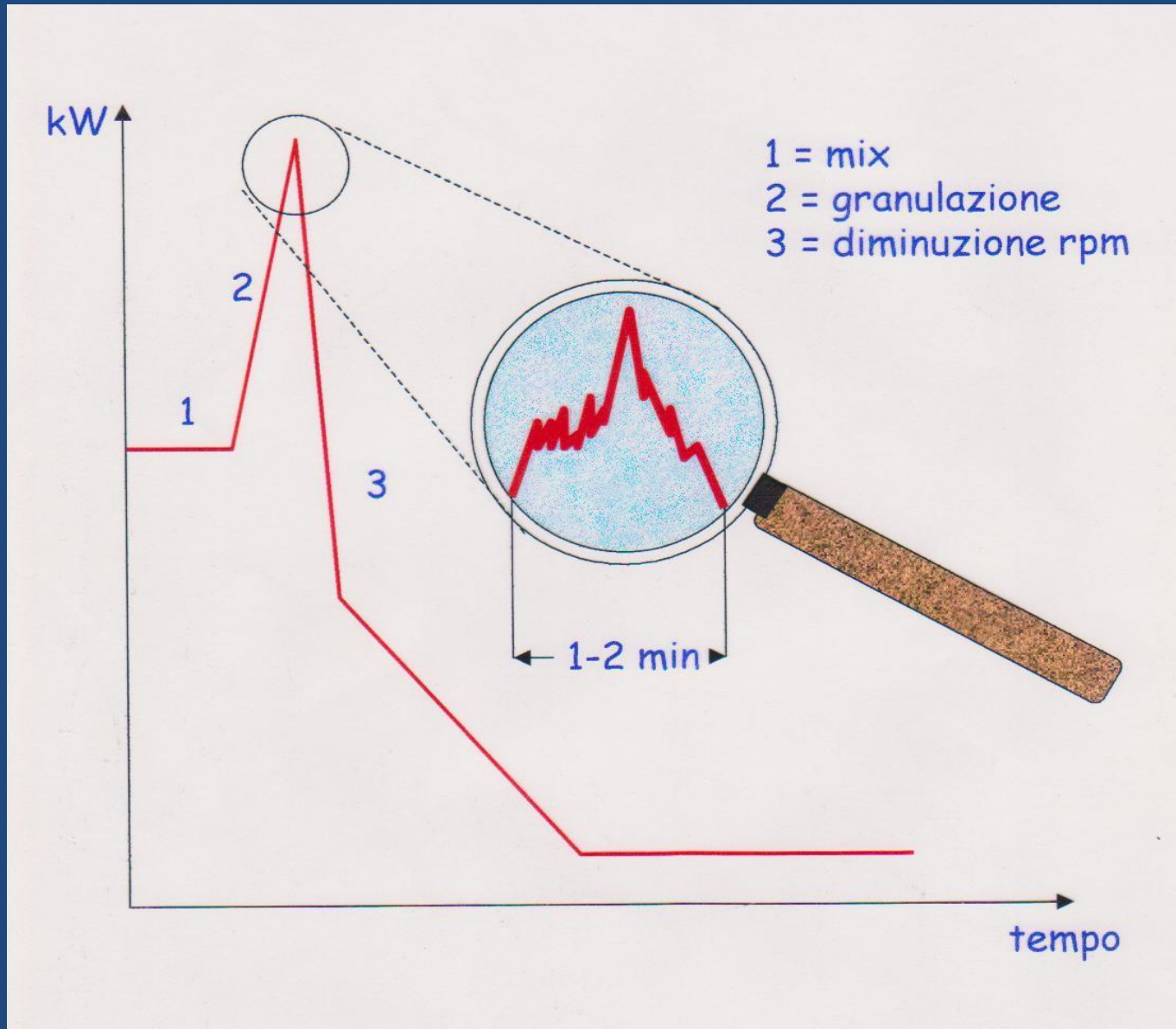

10 LITRI

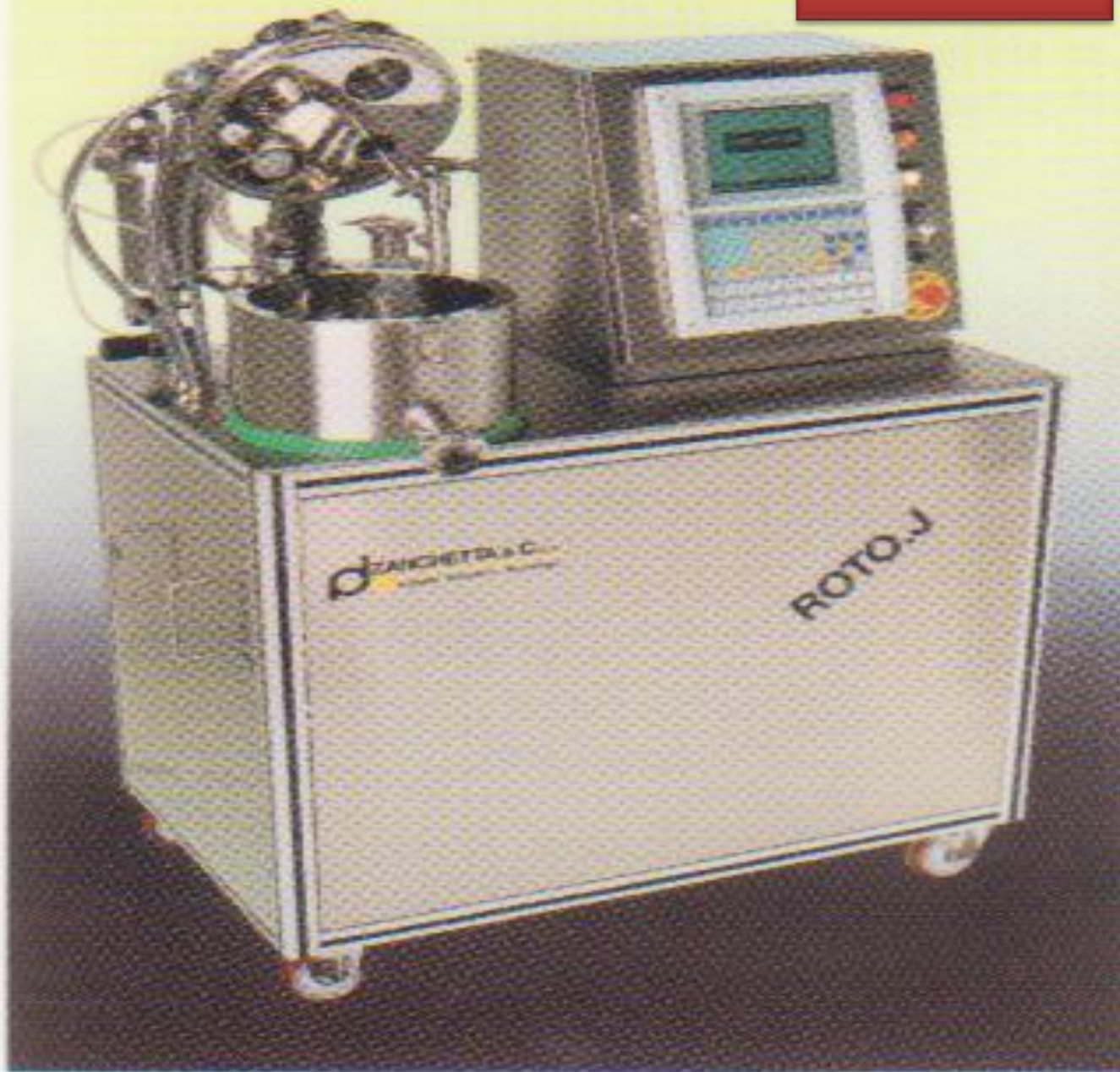



50 LITRI

400 LITRI



900 LITRI



2000 LITRI

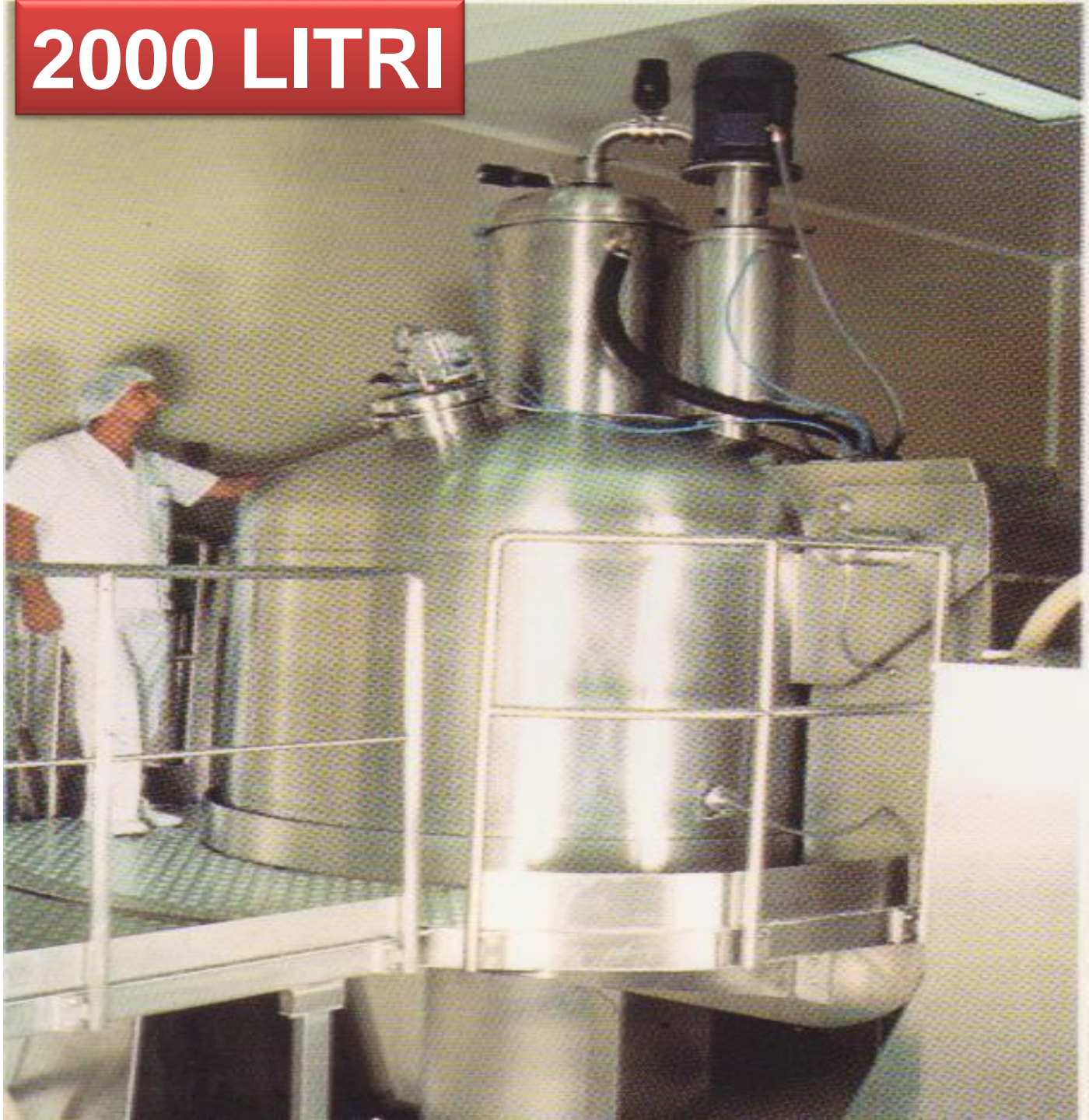

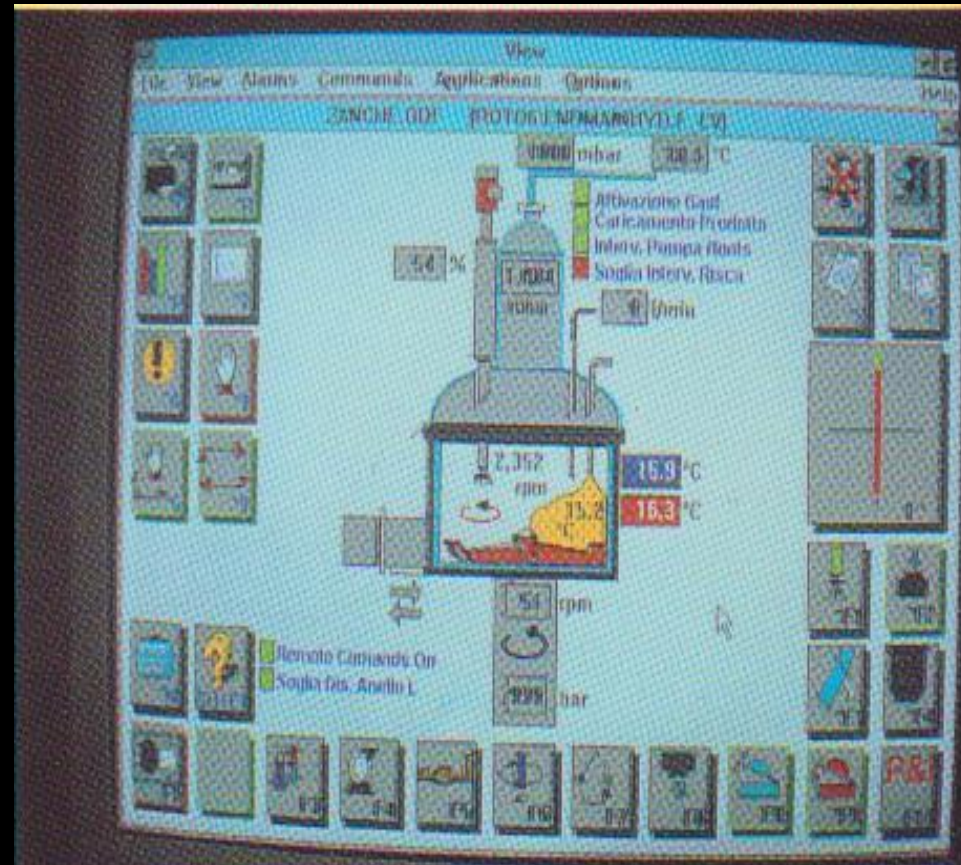
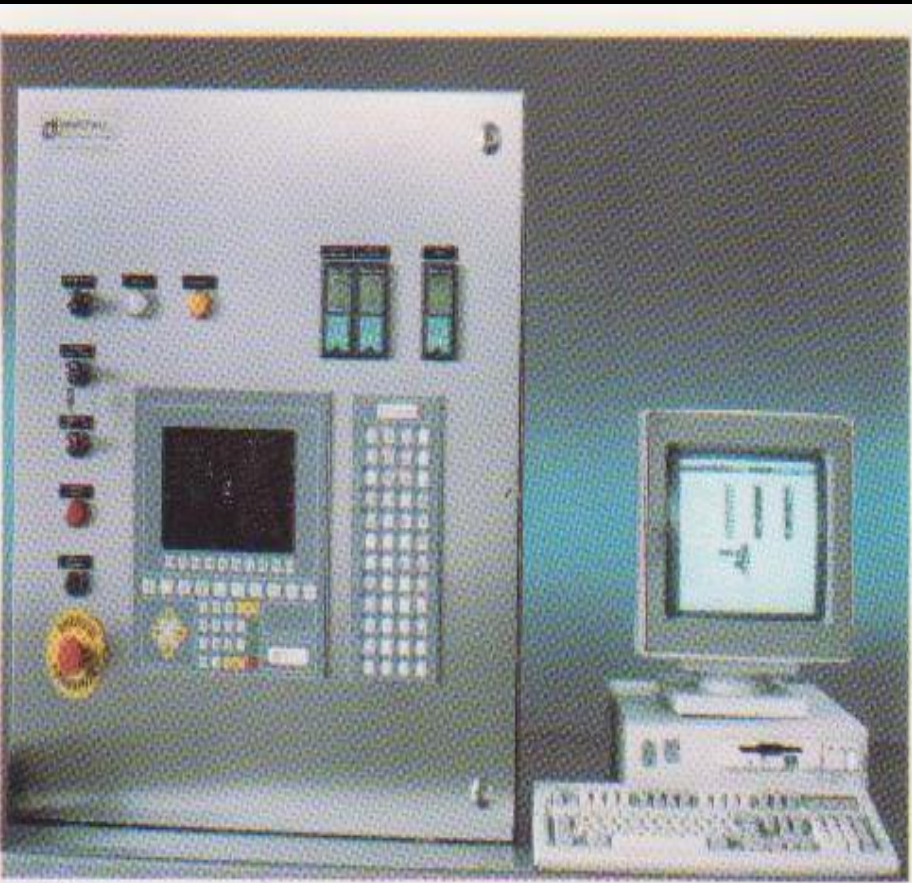

Scale-up



Rotolab 2.8



P10



P50



CUBE 600

3. MODALITÀ DI SPRUZZAMENTO DELLA SOLUZIONE LEGANTE

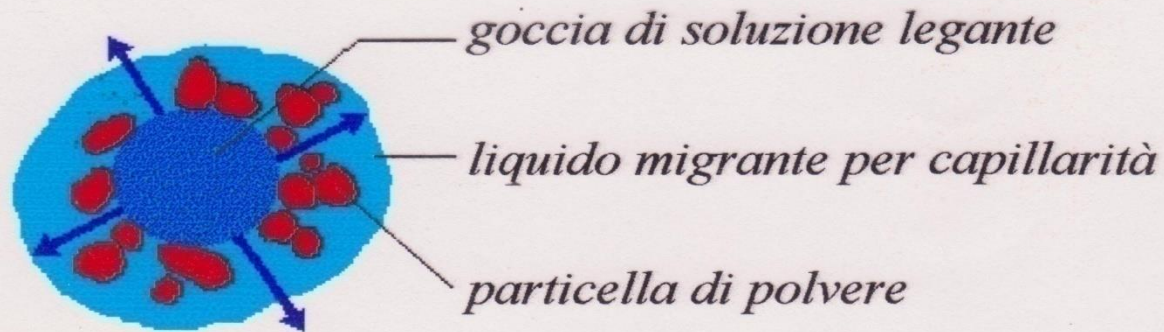

(a)

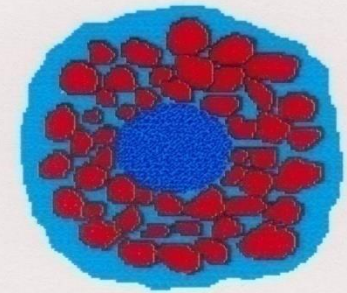

(b)

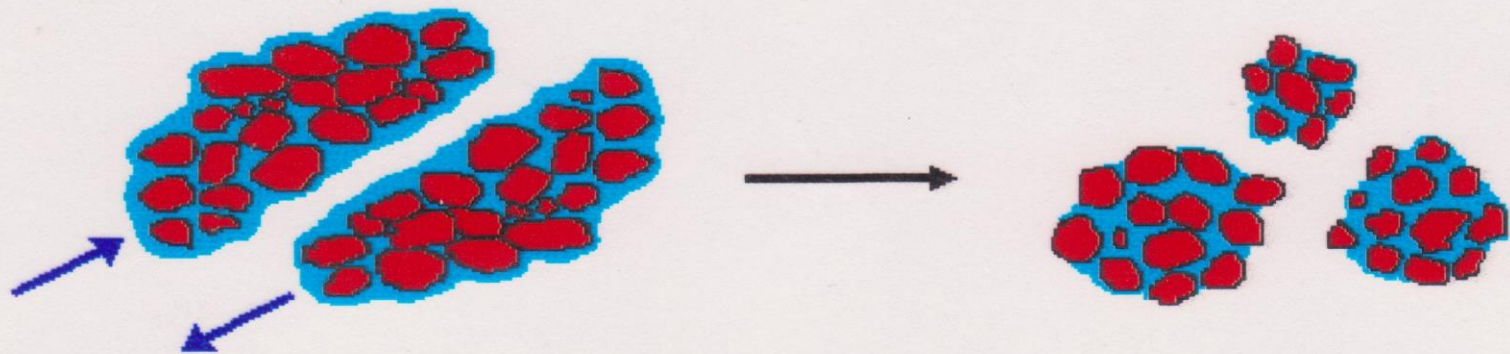

forze di taglio



IMPELLER

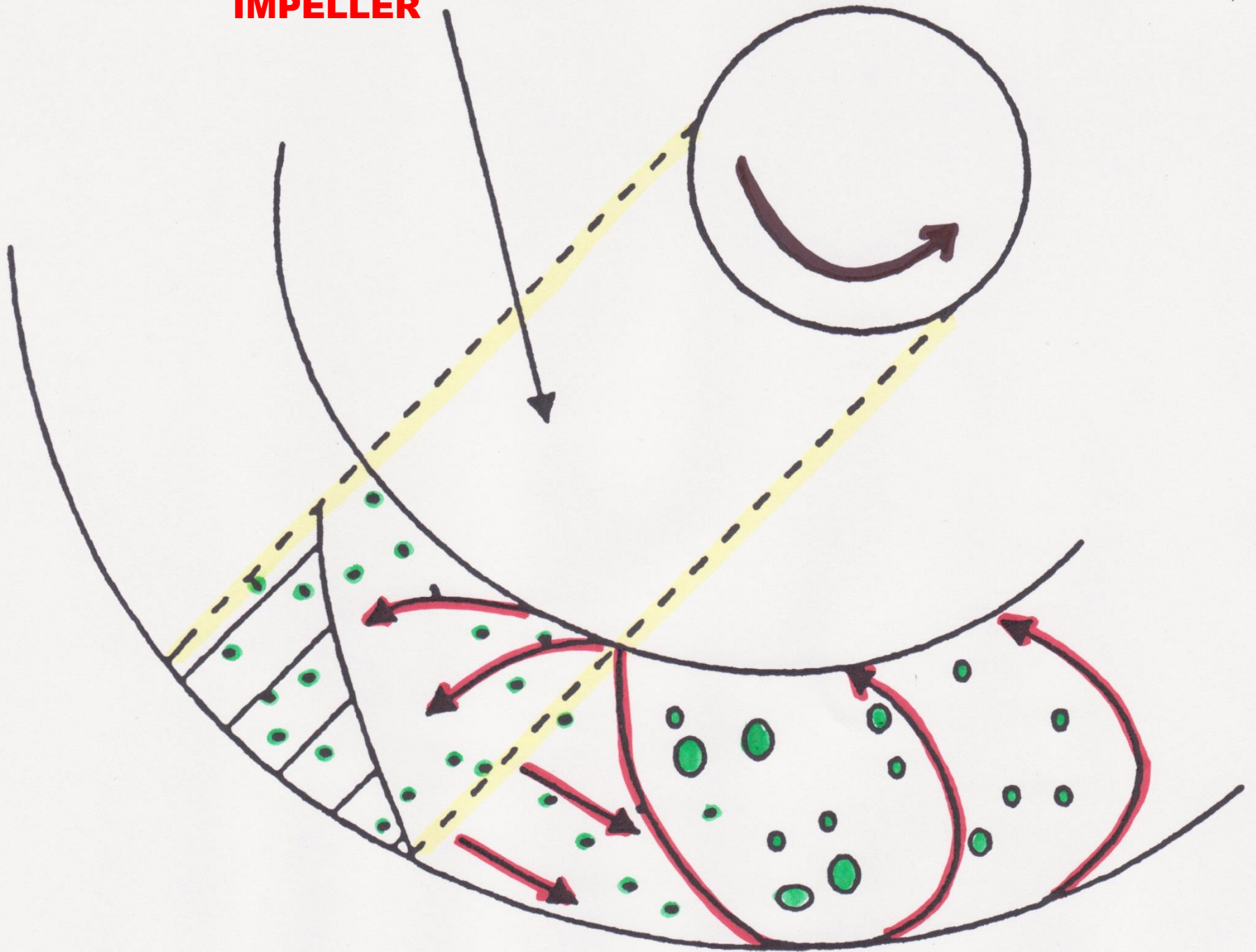

SETTORE DI SPRUZZAMENTO

NEBULIZZAZIONE (UGELLI DI 0,3-1,5 mm ALLA PRESSIONE DI 2 ATM)

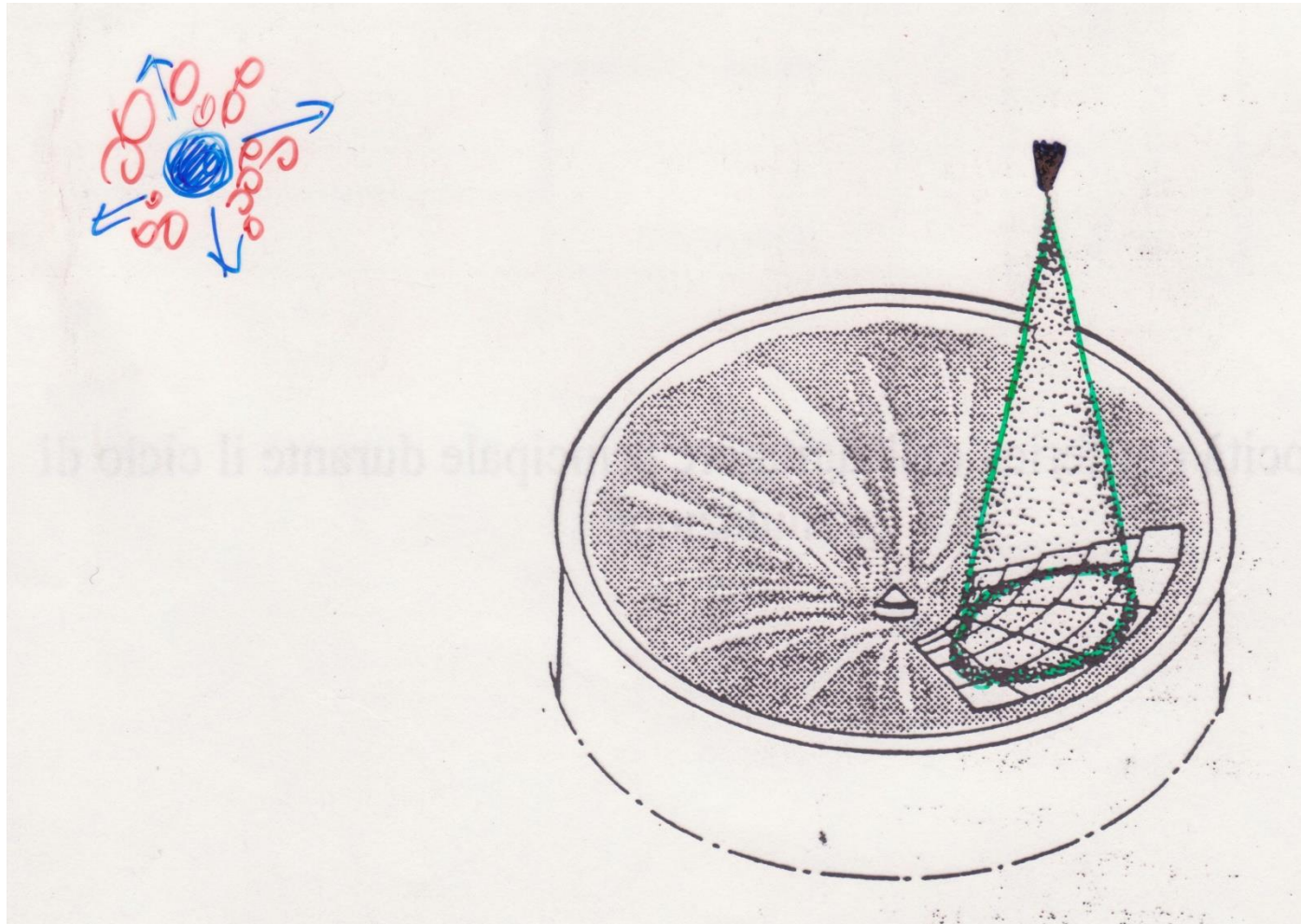

TEMPI DI SPRUZZO DA 1-15 min

4. VELOCITÀ DELL'IMPELLER DURANTE LA FASE DI GRANULAZIONE

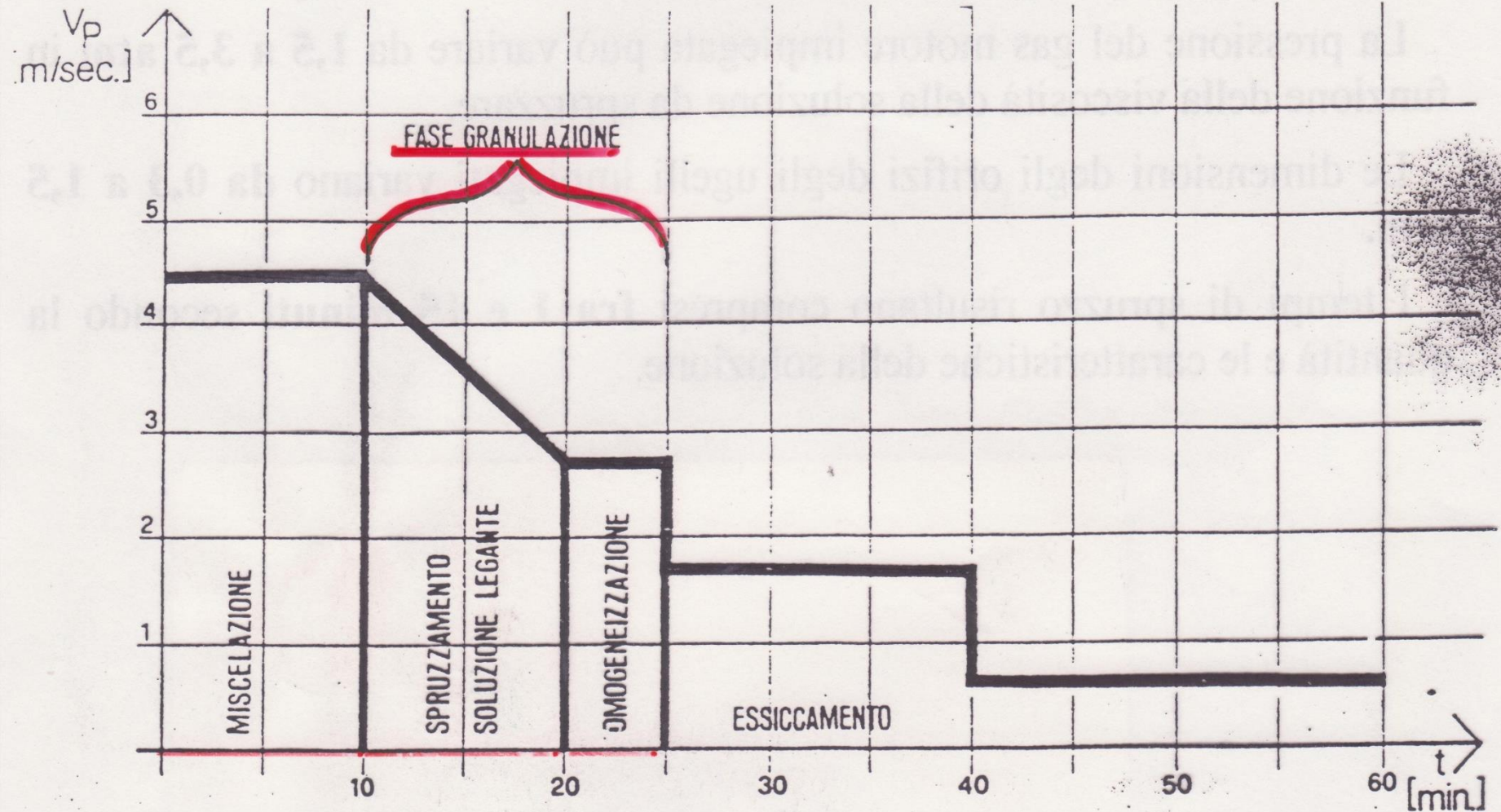

SPRAY-DRYING (ESSICCAMENTO PER NEBULIZZAZIONE)

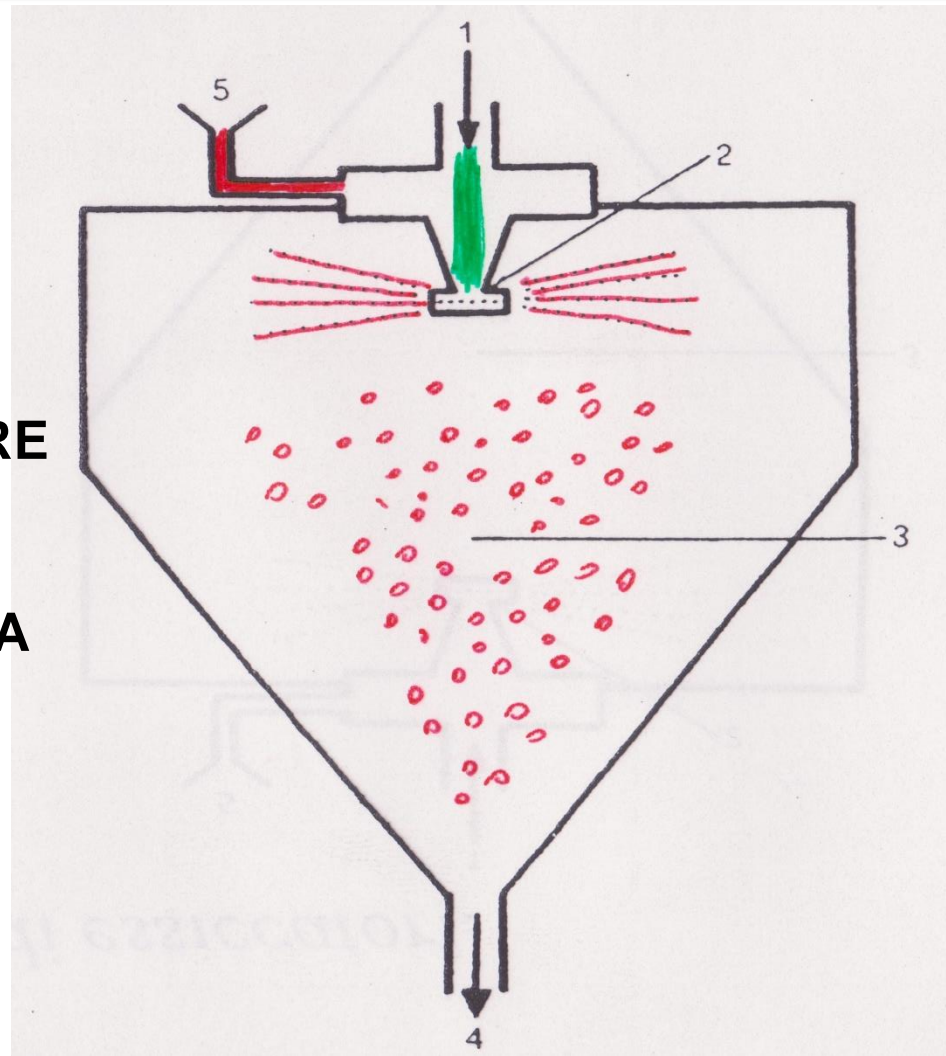

1. ENTRATA
DELL'ARIA
CALDA

2. ATOMIZZATORE

5. ENTRATA
PRODOTTO DA
ESSICCARE

3. CAMERA DI
ESSICCAMENTO

4. USCITA DEL
MATERIALE

Schema di un processo di rivestimento per spray drying e spray congealing

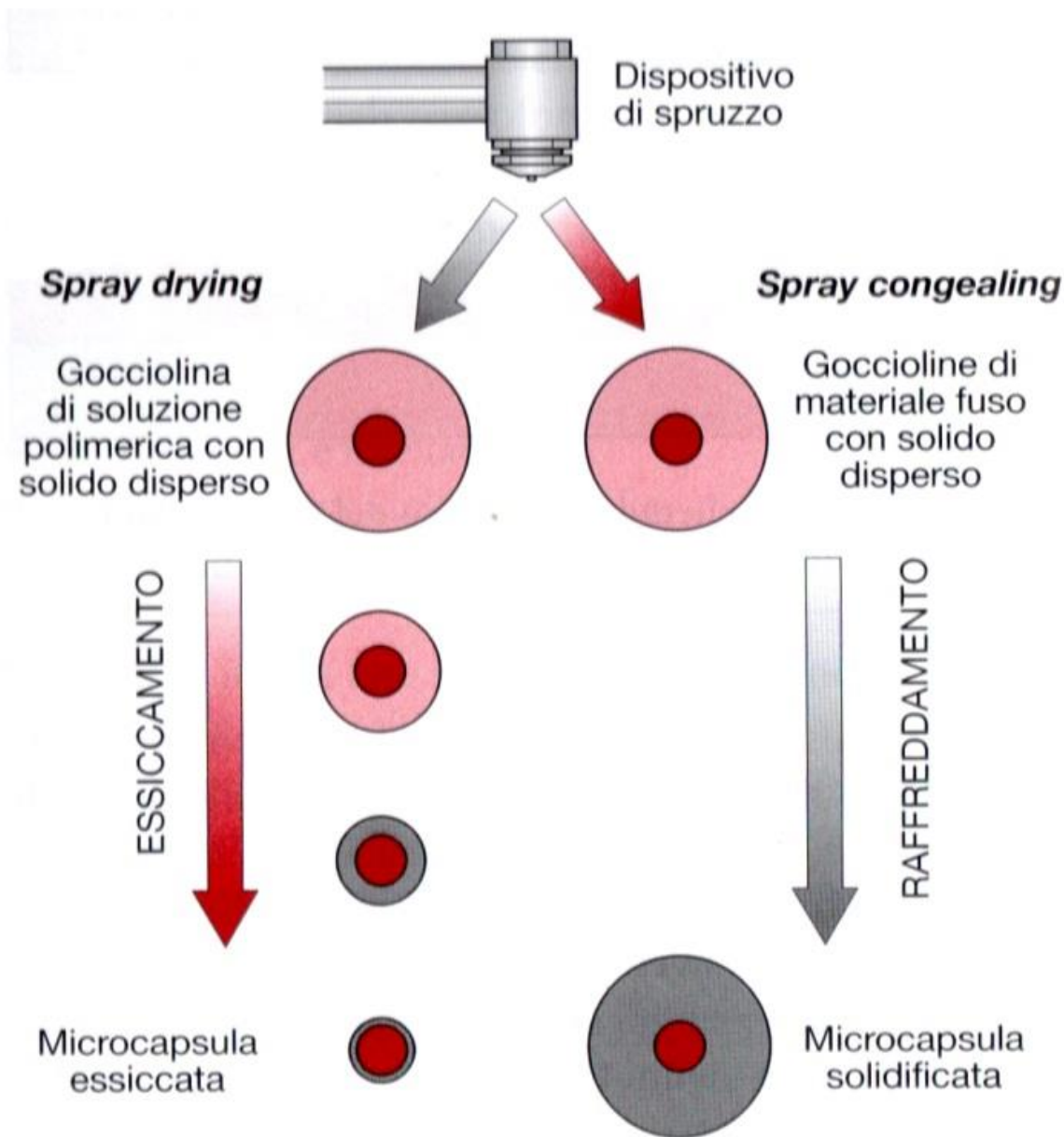

BASSINA

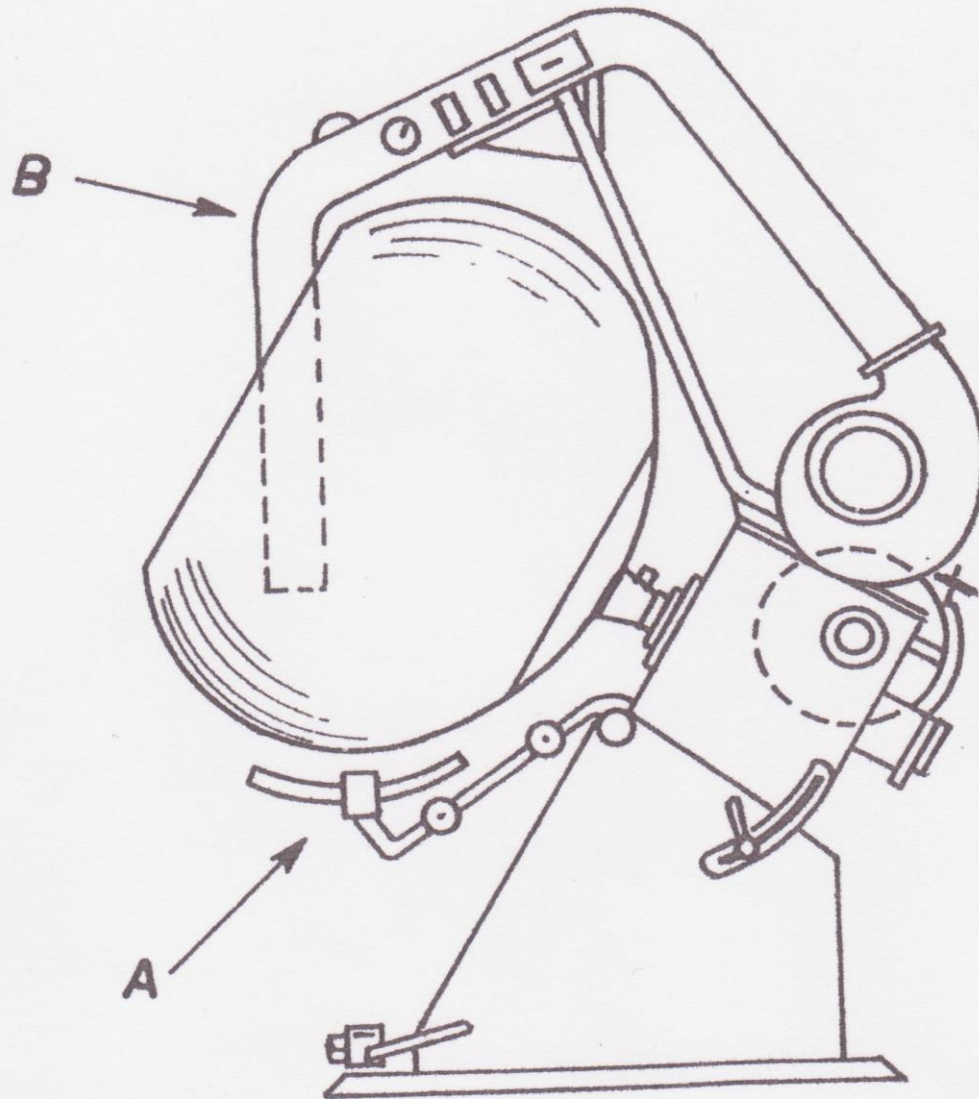

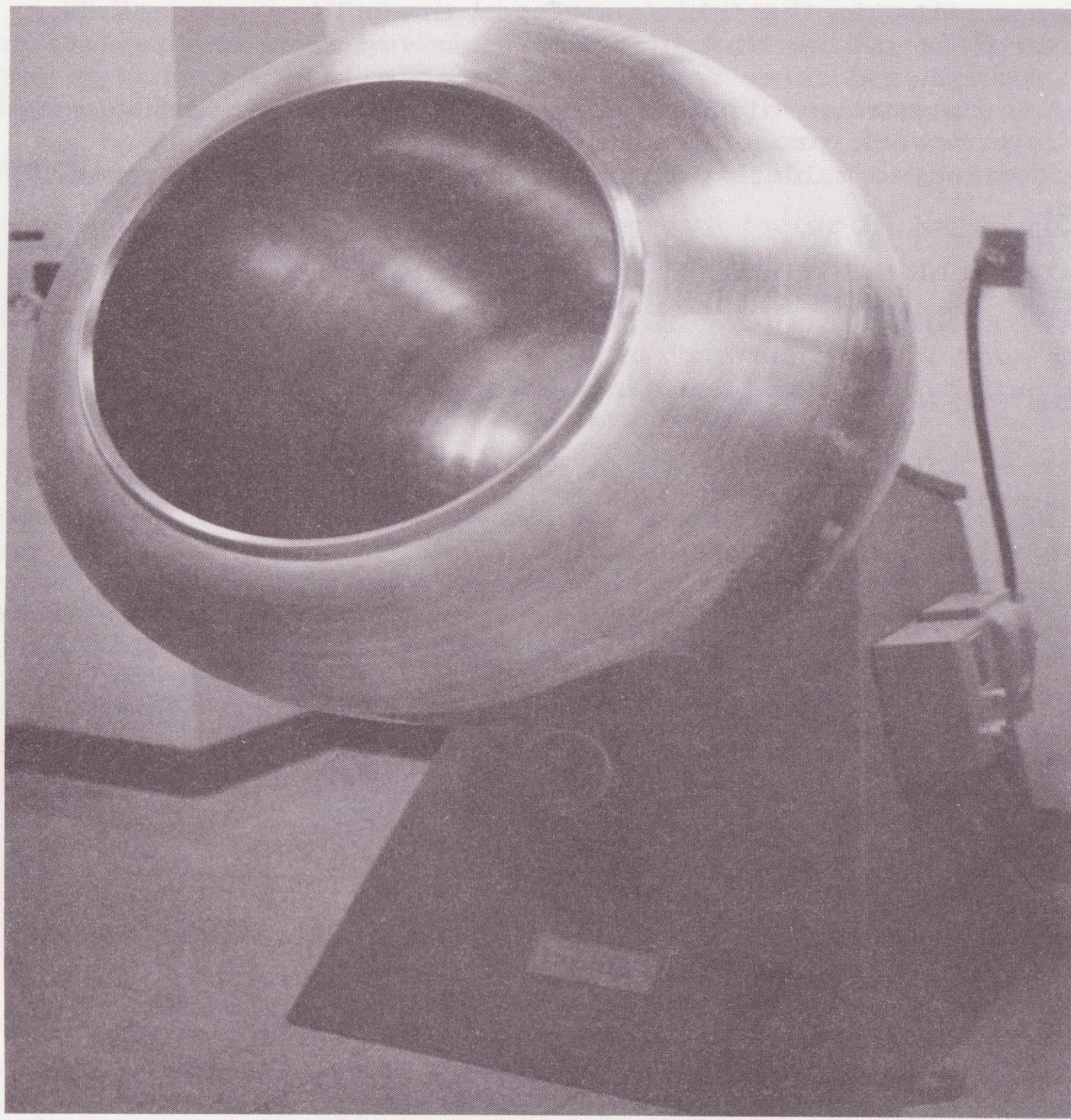

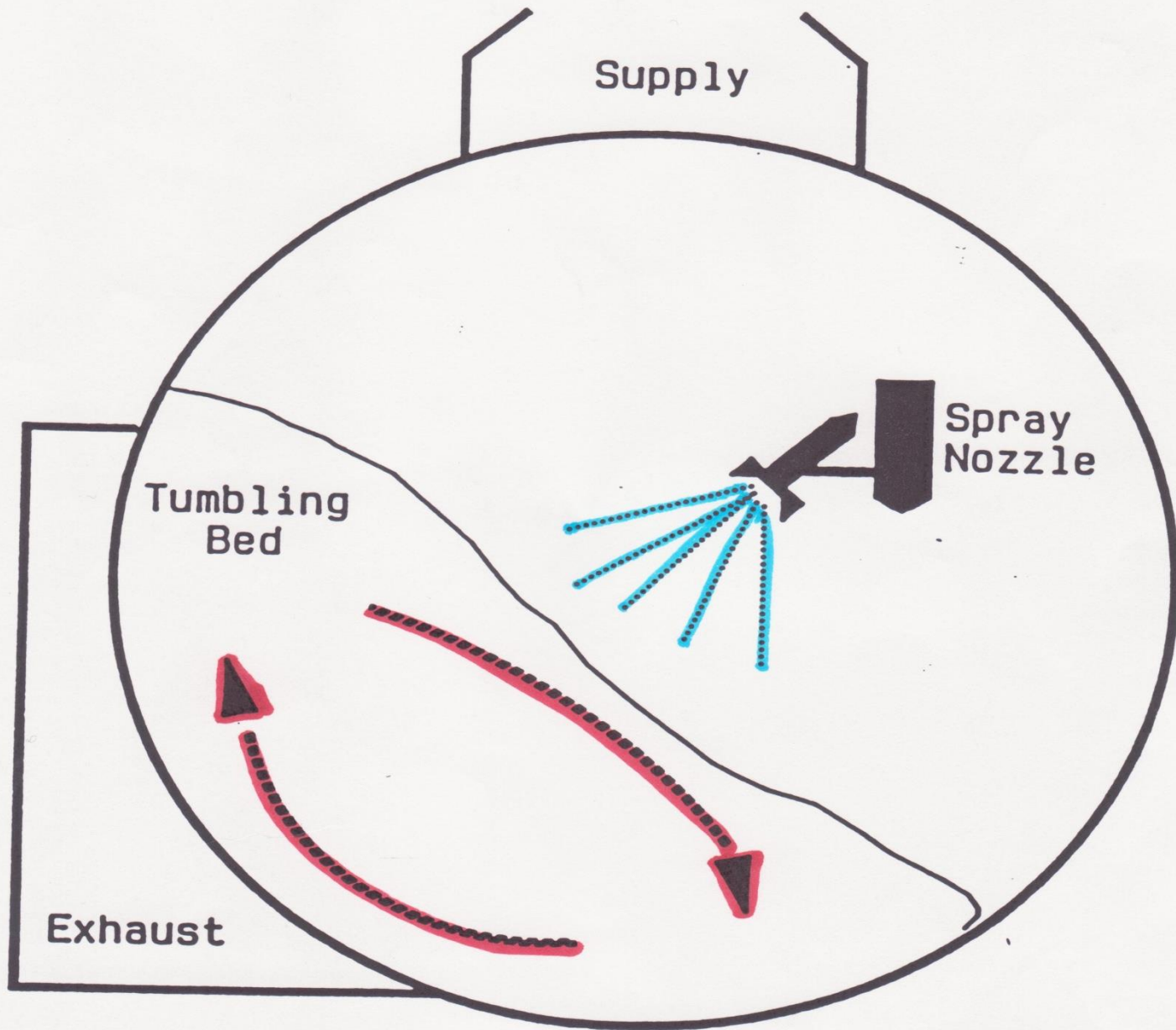

Fig. 5 Perforated pan.

GRANULAZIONE PER FUSIONE

LA GRANULAZIONE PER FUSIONE PREVEDE L'USO DI LEGANTI SOLIDI A BASSO PUNTO DI FUSIONE O RAMMOLLIMENTO (ES., PEG 4000 E 6000, ACIDO STEARICO, CERE).

IL LEGANTE VIENE AGGIUNTO ALLA MASSA DI POLVERE DA GRANULARE PREVENTIVAMENTE RISCALDATA AD UN TEMPERATURA VICINA AL P.F. DEL GRANULANTE STESSO.

PER LENTO ABBASSAMENTO DELLA TEMPERATURA IL LEGANTE RITORNA ALLO STATO SOLIDO E TIENE AGGREGATI I GRANULI.

MECCANISMO DELLA GRANULAZIONE PER FUSIONE



(a)

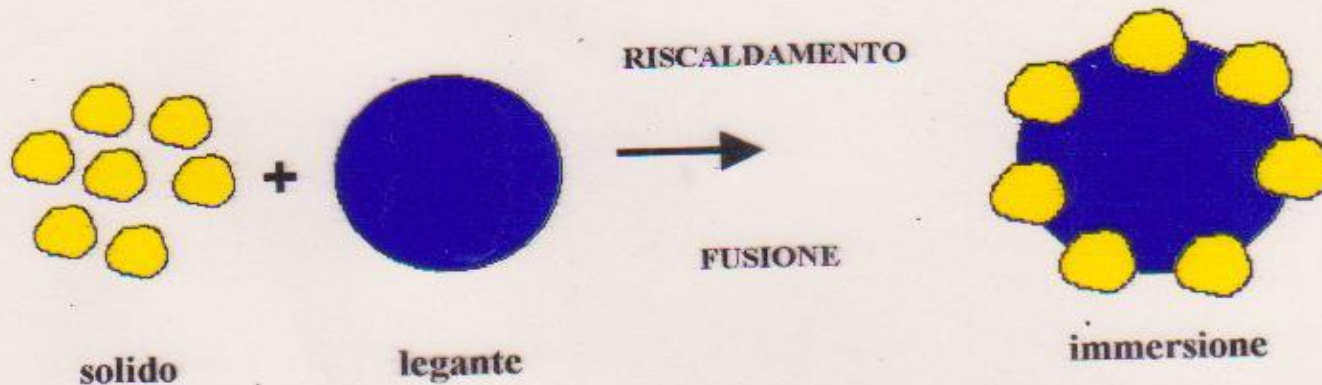

(b)

TEMPERATURA DEL PRODOTTO

