

Prof. Ing. Dario Pozzetto

Department of Engineering and Architecture – University of Trieste

Via Valerio, 10 – 34127 Trieste – Tel: 040.558.3805 / 7982 Fax: 040.558.3812

E-mail: pozzetto@units.it

INDUSTRIAL PLANTS II

Chapter eight (part 1): Waste treatment plants

**DOUBLE DEGREE MASTER IN
“PRODUCTION ENGINEERING AND MANAGEMENT”**

**CAMPUS OF PORDENONE
UNIVERSITY OF TRIESTE**

Waste treatment plants

Generality and definitions

The **waste** is all that is discarded by various human activities. The European Community, with the Directive no. 2008/98/EC defines them as "products" and, in particular, "any substance or object which the holder discards or intends or is required to discard".

The definition of the Italian legislation is given by art. 183 of Legislative Decree no. April 3, 2006 n. 152 (Text Consolidated Environmental), as amended by Legislative Decree December 3, 2010, n. 205: "any substance or object which the holder discards or intends or is required to discard".

The act of "**discard**" is to be understood regardless of the fact that the well can potentially be subject to reuse, directly or following manipulative intervention. According to the Circular of the Ministry of Environment 28.06.1999 the "discard" is equivalent to starting an object or substance to the disposal or recovery.

Waste treatment plants

Generality and definitions

The waste is classified by origin in:

- **municipal waste**

They can be distinguished:

- household waste, including bulky, from local areas, used for domestic activities;
- non-hazardous waste from spaces and places used for purposes other than those of the first point, similar to municipal waste quality and quantity;
- waste from the cleaning of the streets;
- waste of any kind or origin, lying on streets and public areas or on roads and private areas still subject to public use or on sea and lake beaches and on the banks of the waterways;
- vegetable waste from green areas (gardens, parks, etc.);
- waste from exhumations and disinterment as well as other waste from cemeteries;

Waste treatment plants

Generality and definitions

The waste are qualified according to their physical state:

- solid powdered;
- solid not powdered;
- shoveled muddy;
- liquid.

Waste are also classified according to their hazardous properties in:

- non-hazardous waste;
- hazardous waste.

Waste treatment plants

Generality and definitions

Hazardous wastes are those wastes and those wastes municipal household indicated as such by special asterisk in the European Waste Catalogue (CER).

The CER codes are numerical sequences, consisting of 6 figures grouped in pairs (e.g. 03 01 01 are the waste bark and cork), designed to identify a waste, as a rule, according to the production process from which it originated. The first group identifies the chapter, while the latter usually the production process.

The codes, around 839, are inserted inside the " List of waste" set up by the European Union with Decision 2000/532/EC. The codes CER are divided into hazardous and non-hazardous; the first are identified graphically with an asterisk "*" after the digits (e.g. 02 01 08 * are the agro-chemical waste containing dangerous substances).

Waste treatment plants

Generality and definitions

The hazard classes of waste are the following:

- explosive;
- combustion;
- highly flammable, including the highly flammable;
- flammable;
- irritant harmful;
- toxic, including the highly toxic;
- carcinogen;
- corrosive;
- infected;
- teratogenic;
- mutagenic;
- in contact with water liberates toxic gases or very toxic;
- source of hazardous substances;
- eco-toxic.

Waste treatment plants

Generality and definitions

The **toxic waste** are those waste materials that can cause damage or death to living creatures or that can jeopardize the environmental ecosystem. It is produced from industrial and commercial (contain toxic substances such as arsenic, mercury, chromium and lead), but also for domestic use (cleaning products, batteries, cosmetics, gardening), agriculture (chemical fertilizers, pesticides), military (nuclear and chemical weapons), medical services (pharmaceuticals), radioactive sources, light industry (plants of dry cleaning). They can be in liquid form, solid or liquid manure and contain chemical agents, heavy metals, radioisotopes etc. They spread easily and can contaminate lakes, rivers and aquifers.

Waste treatment plants

Generality and definitions

By analyzing the data for the year 2008, from the information of the standard models environmental statement (MUD) you get a domestic production of non-hazardous waste of around 63.1 million tons, a figure that rises to about 72.4 million tons , including the additions made through the use of estimation methods. These quantities are then added those fully estimated, falling within the field of construction and demolition which amounted in 2008 to almost 55 million tons and that bring the total production of non-hazardous waste to about 127.1 million tons. The quantity of hazardous waste amounted instead to approximately 11.3 million tons.

Waste treatment plants

Generality and definitions

As regards the production of municipal waste, however, stops in 2008 to 32.5 million tons. The collection in the North exceeds the target of 45%, but in Central and South are still too far (22.9% and 14.7%). Best Region for recycling is Trentino Alto Adige with 56.8%, while the Sardinia the best performance between 2007 and 2008.

The waste is characterized by a great variety of shapes, sizes and properties of the constituents. It is possible to obtain reliable data of composition of solid waste using appropriate statistical methods during sampling and methodology recommended by official bodies for laboratory analysis (method of splitting into four parts).

Waste treatment plants

Generality and definitions

The analysis by product allows to split the solid waste in the main components which are:

- fine materials or undersize, passing through a sieve mesh of 20 x 20 mm;
- putrescible organic substances (organic material of plant or animal origin);
- cellulosic materials (paper, cardboard etc.);
- inert materials (metals, glass, etc.);
- plastics;
- textile and wood.

On Solid waste, to represent the properties, is done usually chemical-physical analysis, especially for the quantification of mass balances essential to evaluate the changes by processes of anaerobic degradation (landfill and anaerobic digestion), of biological oxidation (composting) and thermal (in incineration).

Waste treatment plants

Generality and definitions

The analysis by type according to the method of subdivision into four parts

1. identification of the sample of waste represents the breakdown of the waste collected in a certain catchment area;
2. method for the analysis of the National Research Council with 3 to 4 tons (load of a vehicle whose path collection was chosen as representative of the average composition of waste in the area under consideration);
3. weighing and division into four parts of the sample, after separation of bulky items (tires, boxes, various cabinets, mattresses, appliances etc.).

Waste treatment plants

Generality and definitions

The analysis by type according to the method of subdivision into four parts

First subdivision into four parts

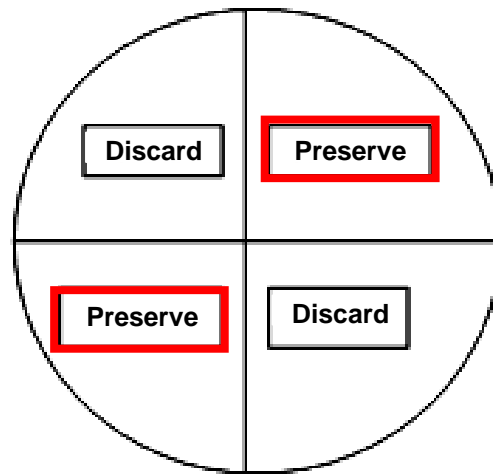

Height 60 cm
Weigh 3000-4000 kg

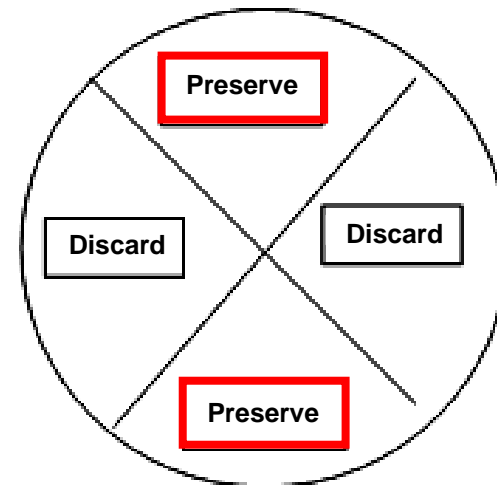

Height 30 cm
Weigh 1500-2000 kg

Waste treatment plants

Generality and definitions

The analysis by type according to the method of subdivision into four parts

Second subdivision into four parts

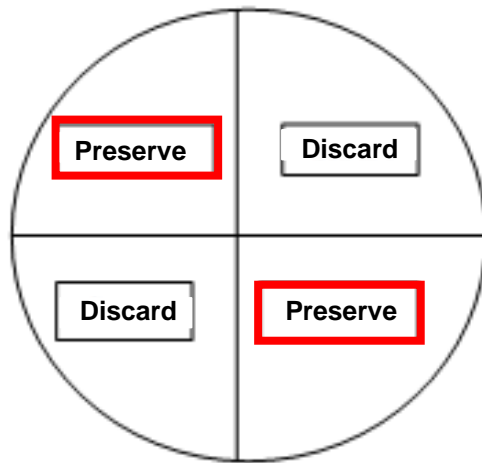

Height 25 cm
Weigh 750-800 kg

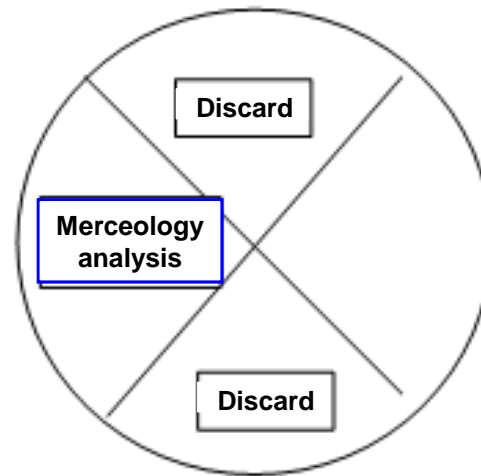

Height 25 cm
Weigh 350-400 kg

Waste treatment plants

Generality and definitions

At the end of the subdivision into four parts is obtained a residue of approximately 200 kg which is the reference material for the evaluation of the breakdown:

1. passing to a sieve (20 mm of light) throughout the mass, collecting the undersize on a sheet of plastic;
2. we proceed to the manual sorting of oversize of product categories adopted;
3. at the conclusion of this operation you will weigh the waste belonging to different classes.

Waste treatment plants

Generality and definitions

The analysis by type according to the method of subdivision into four parts

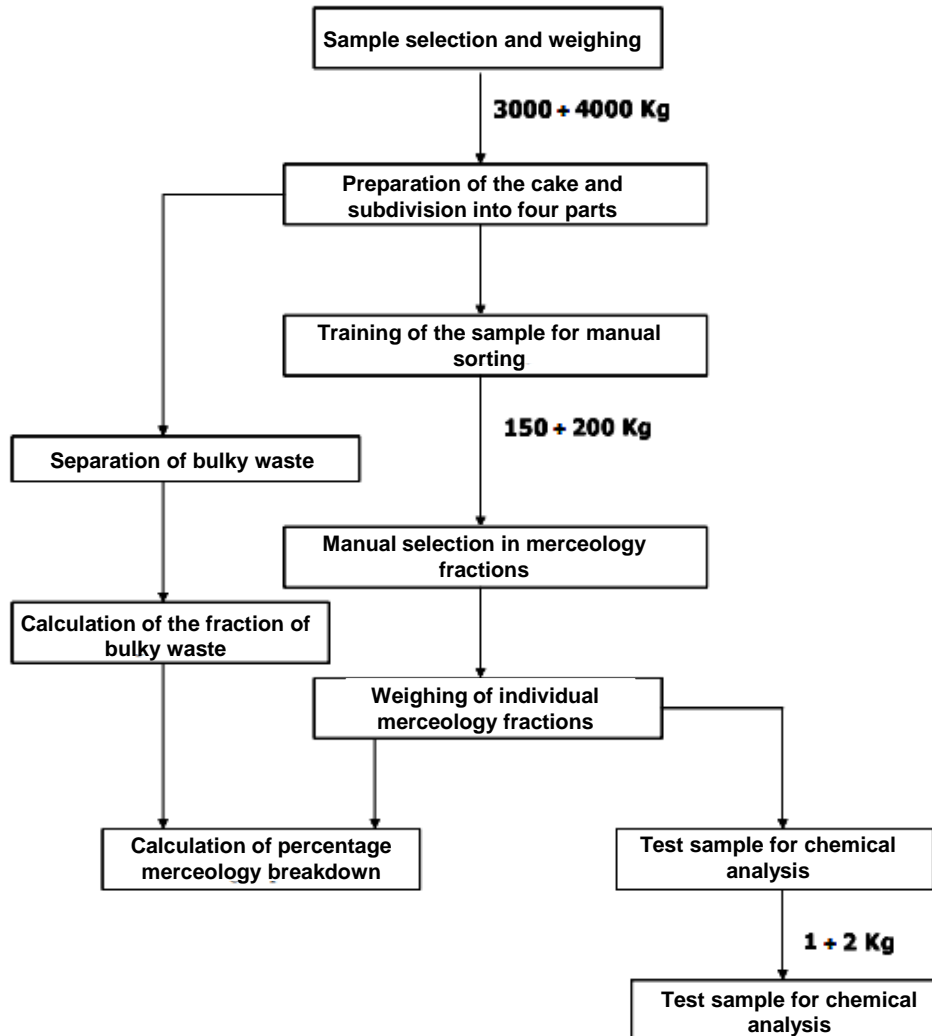

Waste treatment plants

Generality and definitions

It is therefore important to know:

- moisture or water content in solid waste;
- volatile substances and ash on the percentage by weight of the dry substance
- It should be noted that the volatile substances are constituted by the compounds, mostly organic, which volatilize to high temperature oxidation (combustion). It can be assumed that about 50% of the total mass of the organic compounds is constituted by carbon;
- inert substances and fuels;
- density;
- lower calorific value, which is the amount of heat released by the oxidation of a complete unit mass conducted in conditions of temperature (25°C) and pressure (1 bar) prefixed with the bomb Mahler to which is removed the heat released from the combustion of the waste when the water of combustion and the humidity of the waste are in the vapor state (heat of evaporation of water in the flue gas).

Waste treatment plants

Generality and definitions

It is therefore important to know:

- lower calorific value helpful

Differentiated for the different product fractions is has a lower calorific value of:

- | | |
|---------------------------|----------------|
| - plastic and rubber | 31 MJ/kg dry; |
| - textile and wood | 17 MJ/kg dry; |
| - paper and cardboard | 15 MJ/kg dry; |
| - organic cuttings | 12 MJ/kg dry; |
| - organic domestic | 6,2 MJ/kg dry; |
| - organic large utilities | 6,2 MJ/kg dry; |
| - under screen | 5,8 MJ/kg dry; |
| - inert, metal and glass | 0 MJ/kg dry. |

Waste treatment plants

Generality and definitions

The variability of the content of combustible material, moisture and the amount of incombustible residue characteristic of a solid waste, determines a different capacity to the combustion of the waste same, as indicated in the triangular diagram of Tanner (Figure)

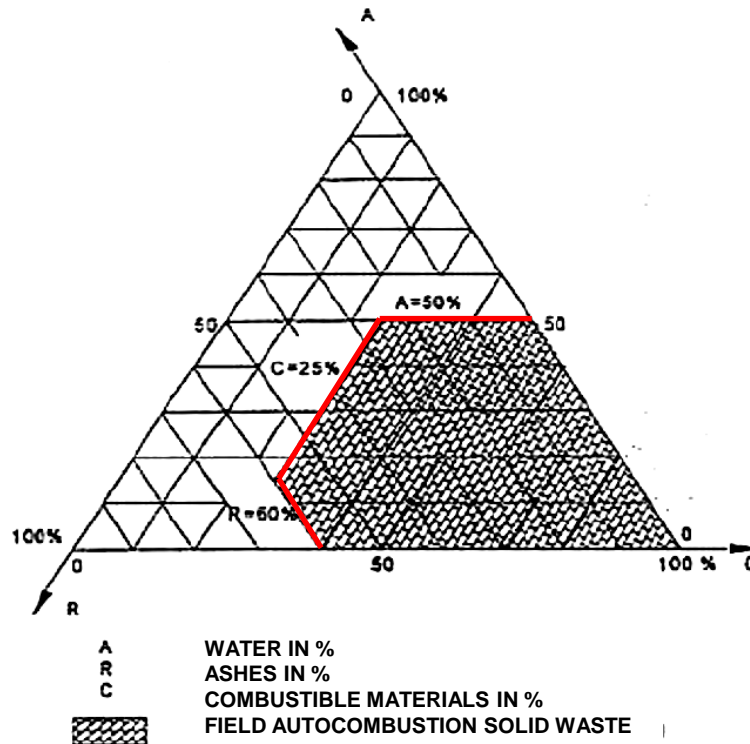

Waste treatment plants

Management and treatment of waste

For **waste management** is defined the set of policies to manage the entire process of waste, from their production to their disposal, and therefore involve the stages of collection, transport, treatment (recycling or disposal) and also reuse waste materials, usually produced by human activity, in an attempt to reduce their effects on human health and the environment.

The **waste treatment** is the set of techniques designed to ensure that waste, whatever their fate, have minimal impact on the environment.

Waste treatment plants

Management and treatment of waste

The diagram of Figure summarizes the methods and supply chains for the treatment of municipal solid waste according to the current management policies

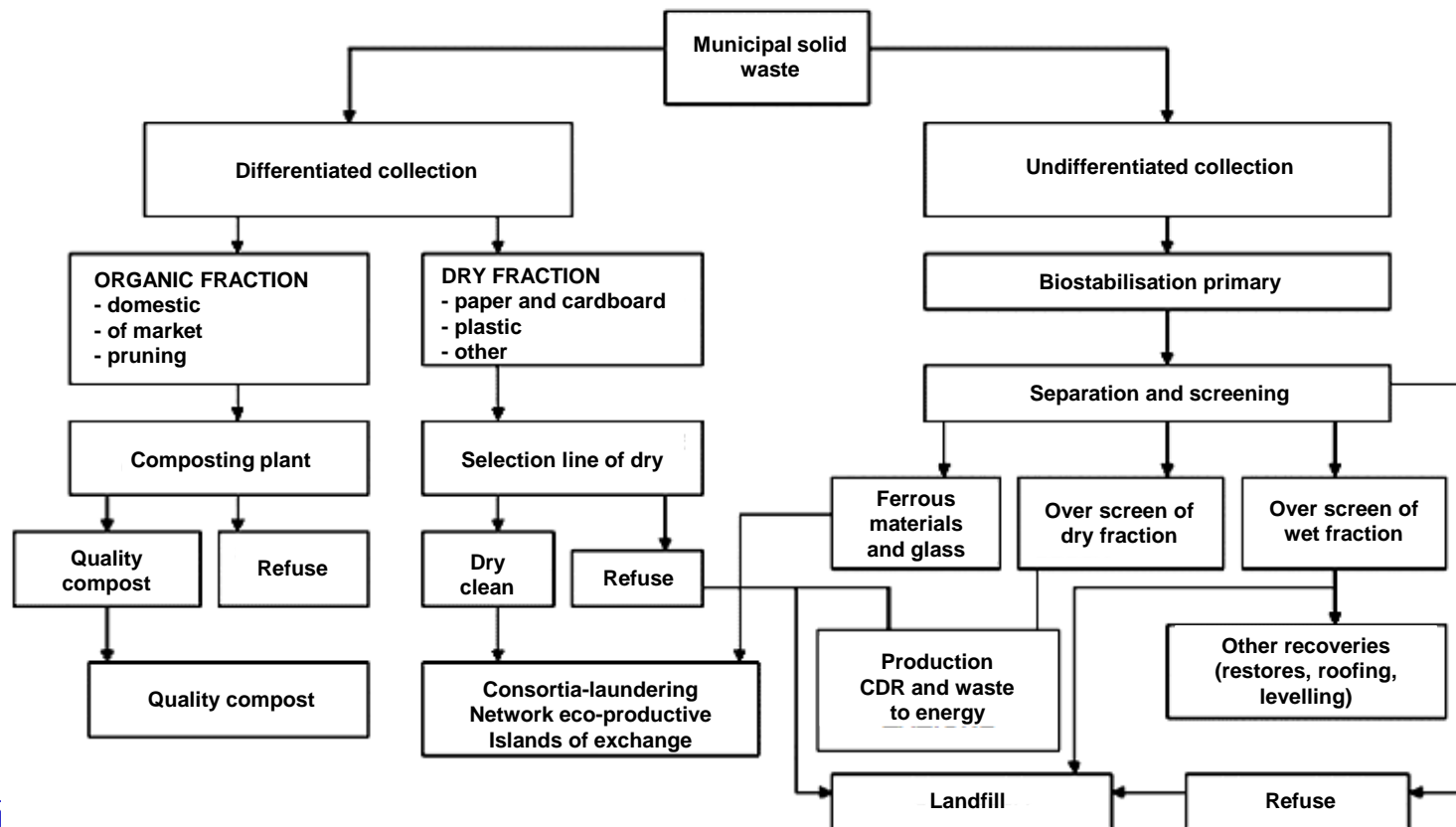

Waste treatment plants

Management and treatment of waste

The Figure shows the scheme for the treatment of the separation of solid waste.

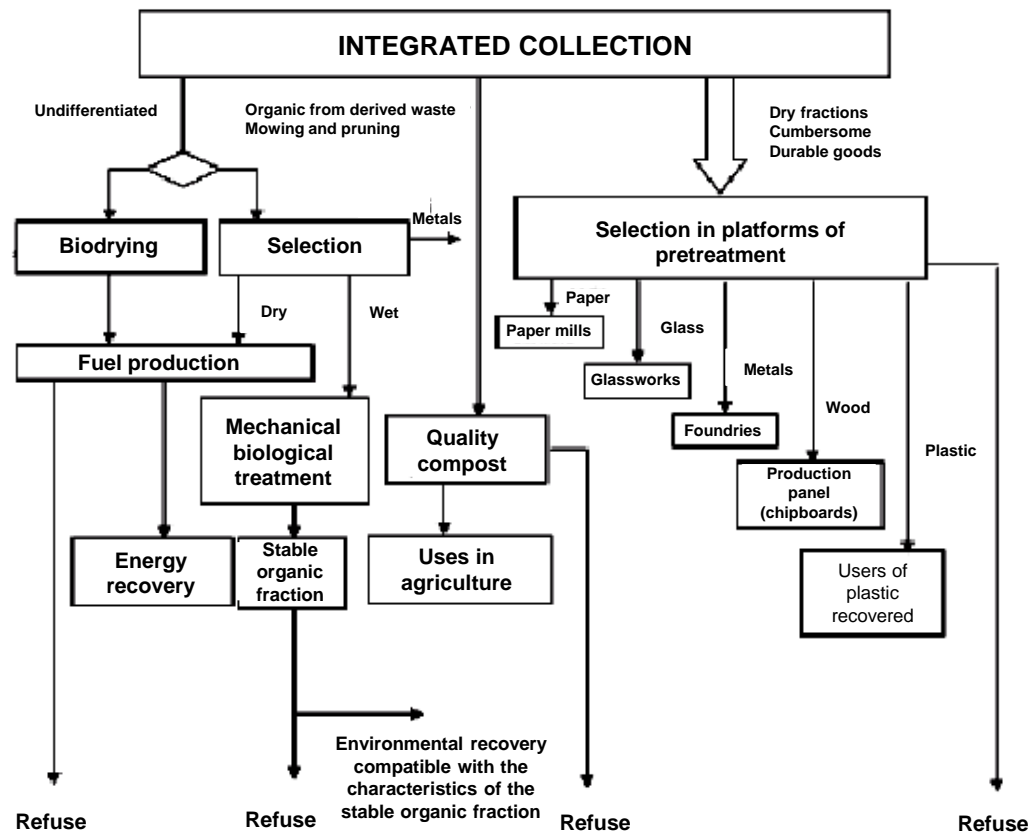

Waste treatment plants

Management and treatment of waste

The strategy adopted by the European Union and implemented in Italy with Legislative Decree n. 152/06 and updated with the changes in the Legislative Decree n. 205/2010 deals with the issue of waste outlining priority actions within a logic of integrated management. They are:

- **priority criteria**, such as the development of clean technologies, the design and marketing of products that do not contribute or give a minimum contribution to the production of waste and pollution, technological improvements to eliminate the presence of hazardous substances in the waste and active role of government in the recycling of waste and their use as an energy source;

Waste treatment plants

Management and treatment of waste

They are:

- **prevention of waste** as the proper assessment of the environmental impact of each product throughout its entire life cycle, the drafting of contract specifications that consider the ability to prevent the production, promotion of agreements and experimental programs to prevent and reducing the amount and harmfulness of waste and the implementation of the Legislative Decree February 18, 2005 n. 59 for the reduction and integrated prevention of pollution;
- **recovery of waste** which reuse, reuse and recycling, the production of secondary raw material by treating the waste, the use of waste to produce energy (energy recovery (cold biological oxidation, gasification, incineration) and facilitate, through the economic measures and specifications in tenders, the market for products reused.

Waste treatment plants

Management and treatment of waste

In addition to the need to prevent the production of waste and reduce their aggressiveness, one must consider the need to re-use products (e.g. with the void

to returnable) and, if you can not reuse, recycle materials (e.g. recycling of paper and cardboard). Finally, only with regard to the material that has not been possible to reuse and then recycle (such as paper towels) and the undersize (i.e. the fraction into small pieces and then indistinguishable non-recyclable waste), the two solutions are placed energy recovery systems using cold or hot, such as bio-oxidation (aerobic or anaerobic), gasification, pyrolysis and incineration, or starting to landfill.

Waste treatment plants

Management and treatment of waste

In an ideal situation of complete recycling and recovery will be a percentage of residual waste to be disposed of in landfill or be oxidized to remove them and recover energy. Incineration and landfill undifferentiated should be limited to the minimum. The lack of effective integrated policies to reduce, recycle and reuse of landfill still make the first solution applied in Italy and in other European Countries. As for the recovery, there are projects and associations dealing with the exchange of goods and products used (for example **CONAI - National Consortium Packaging**, which ensures the recycling and recovery of packaging materials such as steel, aluminum, paper, wood, plastic and glass on the whole national territory)

Waste treatment plants

Management and treatment of waste

According to a survey carried out on municipal solid waste, 46% was sent to landfill, 22.6% to mechanical-biological treatment, of which 2% of the total was used for the production of CDR aimed at energy plants, 10.4% incineration, composting from selected fractions 6.1%, 2.6% ecobales, 0.6% anaerobic digestion and 10.6% other forms of recovery.

CDR – Refuse derived fuel - is a solid fuel crushed dry obtained by the treatment of municipal solid waste, collected generally cylindrical blocks (ecobales)

Waste treatment plants

Management and treatment of waste

Waste prevention consists of a set of policies to discourage, or even prohibit economically penalize the production of materials and products in very short life cycle and become waste without the possibility of reuse. Stakeholders may be both businesses and citizens, incentives to reduce upstream waste production, to make the collection. In addition to a stimulus "ethical", such individuals may be encouraged by a reduction of TARI (waste tax), such as home composting.

The TARI is the tax on the collection of municipal solid waste, you pay for the service of waste disposal by the municipality directly by company specifically empowered to contract. It is calculated based on the surface of the premises regardless of the number of people who hold them. Besides varying each municipality the TARI also changes depending on the use to which the property is intended

Waste treatment plants

Management and treatment of waste

The **waste treatment** is the set of techniques which ensure that the waste has the least impact on the environment. May involve solid, liquid or gaseous, with methods and different research fields for each.

Waste treatment plants

Management and treatment of waste

The modality and chains for the treatment of municipal solid waste are divided into:

a) collection differentiated

Such waste may be treated substantially, depending on the type, using two procedures:

- **recycling**, for dry fractions;
- **composting**, for the wet fraction;

Waste treatment plants

Management and treatment of waste

The modality and chains for the treatment of municipal solid waste are divided into:

b) collection indifferiated

These wastes are much more difficult to treat than those collected separately. Can be followed three main treatments:

- **cold treatments** or **mechanical-biological treatment** by separation and partial recovery of materials, bio-stabilization and landfill;
- **heat treatment** or **incineration of waste** as or downstream separation RDF production through the process of pyrolysis, gasification and landfill;
- **transfer directly to landfill**, which is widely used, but it is certainly to be avoided.

Waste treatment plants

Solid waste recycling

Recycling is an organizational strategy and technology designed to reuse as raw materials waste materials otherwise destined for disposal in landfills or other type of treatment.

In Italy, the rate of collection is gradually growing, but is still below potential. Particularly efficient solutions such as recycling curbside (figure), where adopted, allow to significantly increase the percentage of recycled waste.



Waste treatment plants

Solid waste recycling

There are numerous materials which can be recycled (metal, paper, glass, plastic etc.), But there are complexities associated to materials "polylaminates", that is made from more different materials (bottles of fruit juice or milk), as well as for objects complex (cars, appliances etc.). However, are not insurmountable problems and can be solved with particular technologies.

Particular is the case of the plastic, which exists in many different types and can be formed by many different materials (PET, PVC, polyethylene HDPE, etc..).

These various materials are handled separately and separated from each other: this major complication in the past has made the waste to energy more cost of recycling.

Waste treatment plants

Solid waste recycling

Today special machines can automatically and quickly separate the different types of plastic although collected in one bin, therefore, the adoption of these advanced technologies allows an advantageous recycling.

Unfortunately, in some cases the plastic, typically that of a lower quality, is initiated at the waste to energy plant even if, from the point of view of energy and environment, it is certainly not the best choice.

Waste treatment plants

Solid waste recycling

Recycling is more complex to disposal, so that limits their use. The **recycling system** refers to the entire production process and not only at the final stage; this involves:

- use of biodegradable materials for the production of goods, which facilitate the natural disposal of the material at the time when the product becomes waste;
- use of recyclable materials (glass, metals, polymers selected etc.) avoiding the coupled materials, more difficult or impossible to recycle;
- collection of waste that must greenhouses made upstream of the system. The separation of the materials reduces the costs of reprocessing and to conduct a waste collection effectively is important to the differentiation stage implemented by individual users;
- the adoption of advanced techniques for the recovery of recyclable materials from unsorted waste (for example, the mechanical-biological treatment).

Waste treatment plants

Solid waste recycling

The recycling presents:

- high environmental costs of the process of the transformation of waste;
- low performance in the amount of raw material obtained;
- low quality of the final products.

The most effective systems for waste management are those based on the **reduction of waste** and their **re-use**, where, once the use of an asset it should not be to increase the amount of waste, but, after a simple process of cleaning and maintenance, is used again without the material of which it is composed undergo transformations (e.g. bottles as "voids to make").

Waste treatment plants

Composting of solid waste

The solid waste contain a proportion of organic material, which in the past could be returned to the ground through a series of elementary processes, contributing to its fertilization. The expansion of the concentrations and the mixture of organic waste with inert waste or other harmful to the land use, have made void this practice, until the study of industrial treatment did not offer a way to at least partially close the natural cycles.

The first studies were started in Italy in 1912 by prof. Becceri, who devised a fermentation system for the development of the temperature in the product suitable bacterial activity.

Waste treatment plants

Composting of solid waste

Many processes were then improved so much that the technique of composting can transform waste into a stable and useful, separating it from the impurities and foreign bodies to obtain a standard of satisfactory quality. Composting is therefore a technique through which is controlled, accelerated and enhanced the natural process that must be met any organic substance due to the microbial flora naturally present in the environment.

Waste treatment plants

Composting of solid waste

It is a process of aerobic biological decomposition of the organic substance of aerobic type, which requires a substantial supply of oxygen for its sustenance and that takes place under controlled conditions.

The temperature that characterizes the different stages of the process; In fact, at 50°C we determine the optimal conditions to achieve the maximum efficiency of transformation, while a temperature of 65°C provides some guarantee of the product from the point of view of sanitation because it has a removal of pathogenic forms with different times exposure for the different types of microorganisms.

Waste treatment plants

Composting of solid waste

The composting process consists of the following steps (Figure)

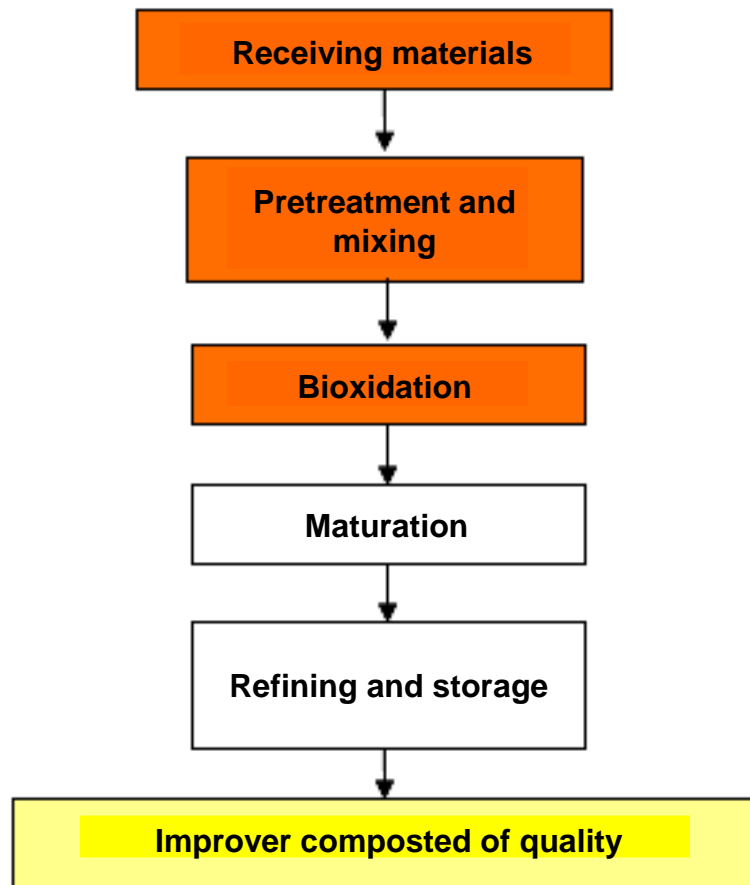

Waste treatment plants

Composting of solid waste

The composting process consists of the following phases:

- **receiving of the materials** (Figure), which receives the organic fraction of municipal solid waste (MSW) in the section consists of a weigh to quantify the input material and a storage area which can be closed and placed under vacuum to avoid the 'emission of odors in the environment;



Waste treatment plants

Composting of solid waste

The composting process consists of the following phases:

- **pretreatment and mixing** (Figure), in which the MSW can be pre-treated by means of systems that allow the opening of the bags of organic material, the mixing with other waste previously shredded (e.g. ligno-cellulosic);



Waste treatment plants

Composting of solid waste

The composting process consists of the following phases:

- **bio-oxidation** (Figure), in which one has the sanitation of the mass and constitutes the first phase of the composting process. It is this the active phase is characterized by intense processes of degradation of organic components more easily degradable.



Waste treatment plants

Composting of solid waste

The composting process consists of the following phases:

- **bio-oxidation**

The mixture is placed inside appropriate structures (such as tunnels, slabs etc.) In which the material is wetted in processing, turned inside out and subjected to air blowing to facilitate and accelerate the processes bio-oxidative that lead to the stabilization of the mass, with carbon dioxide production and an increase in the temperature of the material.

Waste treatment plants

Composting of solid waste

The composting process consists of the following phases:

- **bio-oxidation**

At the end of this phase of the process, the material must comply with an index value of breathing dynamic potential around 1300 mg O₂/kg of volatile substance/h as determined by the regional regulation of competence. The bio-oxidation phase can last 4-5 weeks

Potential Dynamic Respiration Index (IRDP): result of the dynamic respirometric test, which measures the hourly consumption of oxygen used for the biochemical oxidation of readily biodegradable compounds contained in an organic matrix in a condition of forced air insufflations in the sample and expressing the value of the biological stability of the sample after standardization of the main chemical-physical parameters.

Waste treatment plants

Composting of solid waste

The composting process consists of the following phases:

- **maturation**, during which the product stabilizes enriched with humic molecules, which give the compost the characteristics of soil improver. This is the phase of care, characterized by the processes of transformation of the organic substance whose maximum expression is the formation of humic substances (one of the main components of the organic substances of the soil, while the other are not humified organic substances). In this phase, considerably slow down the degradation reactions, it is observed a drop in temperature and decreases oxygen consumption. It assists to a lowering of pH values related to the phenomena of synthesis.

Waste treatment plants

Composting of solid waste

The composting process consists of the following phases:

- **maturation**

The maturation phase lasts a minimum of about 45 days (Figure).



Waste treatment plants

Composting of solid waste

The composting process consists of the following phases:

- **refining and storage** (Figure), in which the material obtained at the end of the ripening phase is subjected to sieving in order to remove the coarse parts (for example, scraps of wood) and undesired (e.g. glass). At the end of this phase, the compost is similar to the soil of undergrowth, dark brown and almost odorless.



Waste treatment plants

Composting of solid waste

The composting process may relate to organic matrices of preselected waste (such as the organic fraction of municipal waste collection in a differentiated manner or organic residues of agro-industrial) for the production of a soil improver composted to be used in agriculture or activities florovivaistiche (compost of quality).

In the case of treatment of mixed waste for the recovery of the organic fraction through composting, these are started in mechanical-biological treatment systems for the production of Stabilised Organic Fraction (FOS) to be used in various non-agricultural uses, such as the use for activities landscape and environmental restoration (eg the recovery of former quarries) or for the daily cover of landfills.

Waste treatment plants

Composting of solid waste

The composting of organic waste collected separately and subsequent use of compost in agriculture brings the following benefits both in agronomic terms, both in the environmental ones:

- you subtract to conferral in landfill waste that otherwise would produce leachate and biogas;

The leachate is a liquid that draws its origin mainly by infiltration of water into the mass of the waste or from the decomposition of the same.

Biogas is mixture of different types of gas (mostly methane 50-80%) produced by bacterial fermentation in anaerobic (absence of oxygen) of the organic residues from waste, decaying plant, in rotting carcasses, slurry or sludge sewage, waste agro-industry. It is the end product of anaerobic biological transformation of the organic substance in which in the absence of oxygen, we have::

$C_{organic} \rightarrow CH_4 + CO_2 + H_2O + \text{trace of pollutants}$

The biogas composition is: CH_4 50-65%, CO_2 30-45%, others 5-10% including H_2S , NH_3 , mercaptans, O_2 , N_2 e H_2O .

Waste treatment plants

Composting of solid waste

The composting of organic waste collected separately and subsequent use of compost in agriculture brings the following benefits both in agronomic terms, both in the environmental ones:

- you produce compost, which improves the physical-chemical characteristics of the soil and the biological activity of the microorganisms and of the roots of the plants, favoring an easier processing of the same, also reducing the mechanical operations of preparation;
- the organic substance put down, with the compost is a deposit of CO₂;
- reduces the use of synthetic fertilizers in the soil due to the accumulation of nutrients in organic slow-release;
- you decrease the use of pesticides through the power phyto-repressive;
- increases the water holding capacity of soils;

Waste treatment plants

Composting of solid waste

The composting of organic waste collected separately and subsequent use of compost in agriculture brings the following benefits both in agronomic terms, both in the environmental ones:

- costs of plant limited;
- opportunity to sell at remunerative prices the compost produced;
- ease of handling even for sludge or liquid discharges urban;
- possibility of building installations in the vicinity of the collection centers.

Waste treatment plants

Composting of solid waste

The disadvantages that this type of plant can be given are:

- management costs quite high;
- need for areas of considerable size for the bio-oxidation, the maturation and storage of the compost;
- need for sale in limited periods of the year and retrieval of the market;
- need for a complementary system for the waste (incineration or landfill).

Waste treatment plants

Composting of solid waste

The Legislative Decree 152/06 defines compost as "a product obtained from the composting of organic waste in respect of specific technical regulations aimed at defining the content and uses compatible with the environmental and health protection". The decree was to enact a regulation that would prescribe the technical standards, the terms and conditions of use of the product obtained by composting, with particular reference to the use as fertilizer agronomic quality product obtained by composting organic waste at the source selected with separate collection. Currently it's still acting interministerial July 27, 1984 which states that the compost "is a product obtained by a process by aerobic biological organic component of municipal solid waste, organic materials from natural fermentable or their mixtures with sludge derived from processes of water purification discharge of civilian settlements".

Waste treatment plants

Composting of solid waste

The same prescribes the agronomic characteristics of the compost (percentage of dry matter of inert materials, glass, plastics, ferrous materials, moisture, organic matter, substance humidified, total nitrogen, ratio C/N, P_2O_5 , K_2O and grain size), the limits acceptability (salmonella, weed seeds, pH, arsenic, cadmium, chromium III, chromium VI, mercury, nickel, lead, copper and zinc) and the maximum concentrations of the metals in soils on which can be the administration of the compost, and the quantity maximum metals applicable annually on the same land (arsenic, cadmium, chromium III, chromium VI, mercury, nickel, lead, copper and zinc).

Waste treatment plants

Composting of solid waste

The Legislative Decree 29 April 2006, n. 217 shows that the fertilizer can be marketed if they are satisfied the instructions given over the same legislative decree, even in the Regulation EC n. 2003/2003 and also that the products, using the composition processed products of animal origin, may be placed on the market provided that they comply with the requirements and processing standards laid down in Regulation EC No. 1774/2002, as amended, provided that such animal products fall within the scope of the regulation.

Waste treatment plants

Mechanical-biological treatment of solid waste

The mechanical-biological treatment is a technology of cold treatment of mixed waste and/or advanced from the collection, which uses the combination of mechanical processes in biological processes, such as anaerobic digestion and composting.

Specific machines separate the wet fraction or organic bio-drying the dry fraction, such as paper, plastic, glass, aggregates etc.; this fraction can be partly recycled or used to produce waste-derived fuel (CDR) removing combustible materials.

Waste treatment plants

Mechanical-biological treatment of solid waste

From the mechanical-biological treatment generates the bio-stabilized, which is distinguished from the compost as it is produced from mixed waste, while the compost is produced from organic material separately collected. For this reason the bio-stabilized is not used as agricultural fertilizer, but, being characterized by a fermentability reduced up to 90%, is particularly suitable for various applications times to the recovery environment, the landscape and the daily covering of landfill without emissions of methane CH_4 , which is also a greenhouse gas more potent, if released into the atmosphere as it is, the carbon dioxide CO_2 .

The CDR obtained serves to fuel the waste to energy plants.

Waste treatment plants

Mechanical-biological treatment of solid waste

A plant that produces bio-stabilized wastes is the first receipt of the materials which is followed by weighing and storage in mass storage and closed in depression to avoid spills smelly. Following the extraction of the waste from the pit by a crane Grapple mounted on a sliding bridge or with a screw extractor in order to serve the conveyor belt which conveys them to the first sifting coarse (Figure) to eliminate unwanted bulky waste, which are recovered and sold as have some commercial value (Figure).

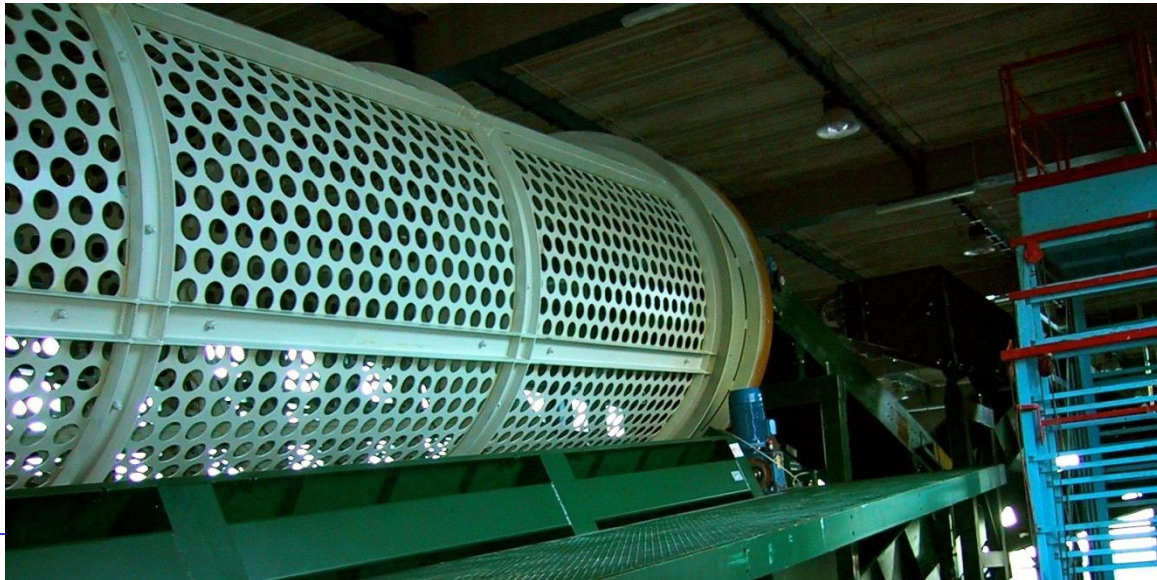

Waste treatment plants

Mechanical-biological treatment of solid waste

Unwanted bulky waste recovered and sold



Waste treatment plants

Mechanical-biological treatment of solid waste

The sorting is carried out by means of magnetic separators continuous, that overhang for a certain distance the conveyor belt and which adhere progressively the metal fragments or drum which present the drum motor magnetized as a result of the magnetic field are made to follow different trajectories of ferrous and those non-ferrous metals (Figure).

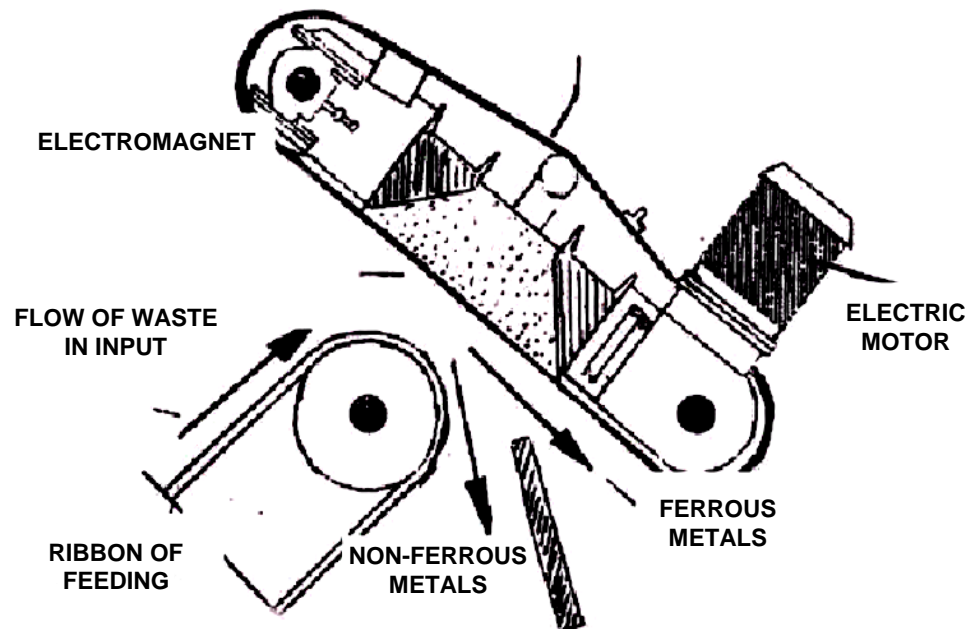

Waste treatment plants

Mechanical-biological treatment of solid waste

It then has a crushing operation that serves to homogenize the waste which also undergoes a decrease in the size. Shredding, no special thrust otherwise you may pollute too much the end product of metals and inert. The most common crushers are hammers (Figure), with rotating blades and ball bearings or may be employees of the mills screw (Figure).

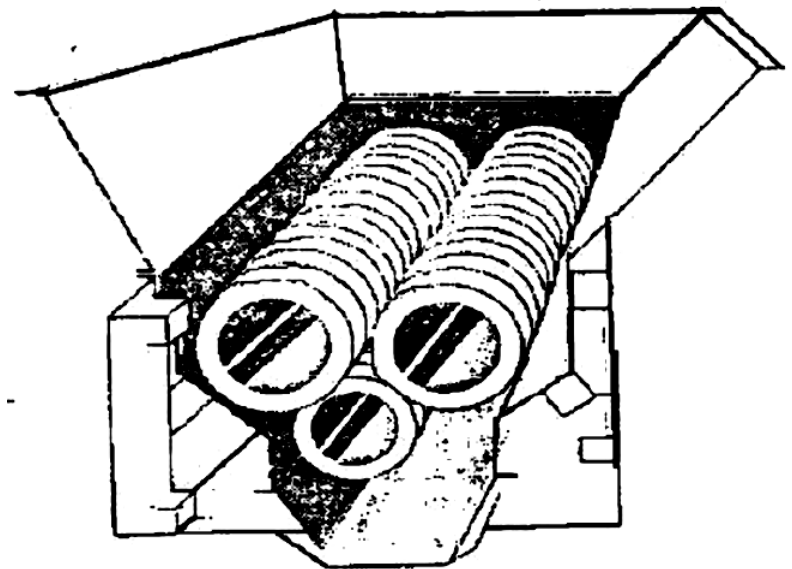
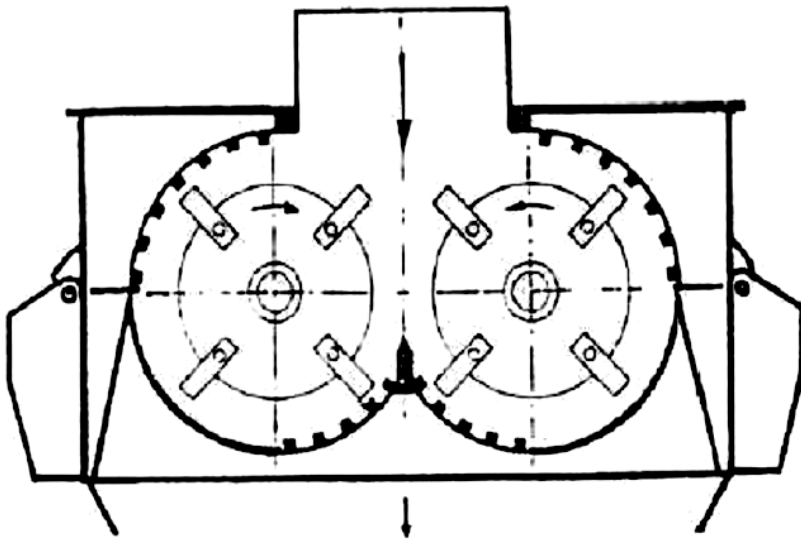

Waste treatment plants

Mechanical-biological treatment of solid waste

It has then a new sifting with separation of a coarse fraction and little fermentable, consisting for example of paper, cardboard, plastic, metals, glass etc., and a part rich in organic matter and highly fermentable.

The bio-chemically fraction inert is started for disposal/recycling, while the organic matter is subjected to removal of the organic content and biological treatment of accelerating fermentation and then produce the final material at low fermentability.

Waste treatment plants

Mechanical-biological treatment of solid waste

The biogas is recovered and it is also possible to derive any of the CDR (Figure)

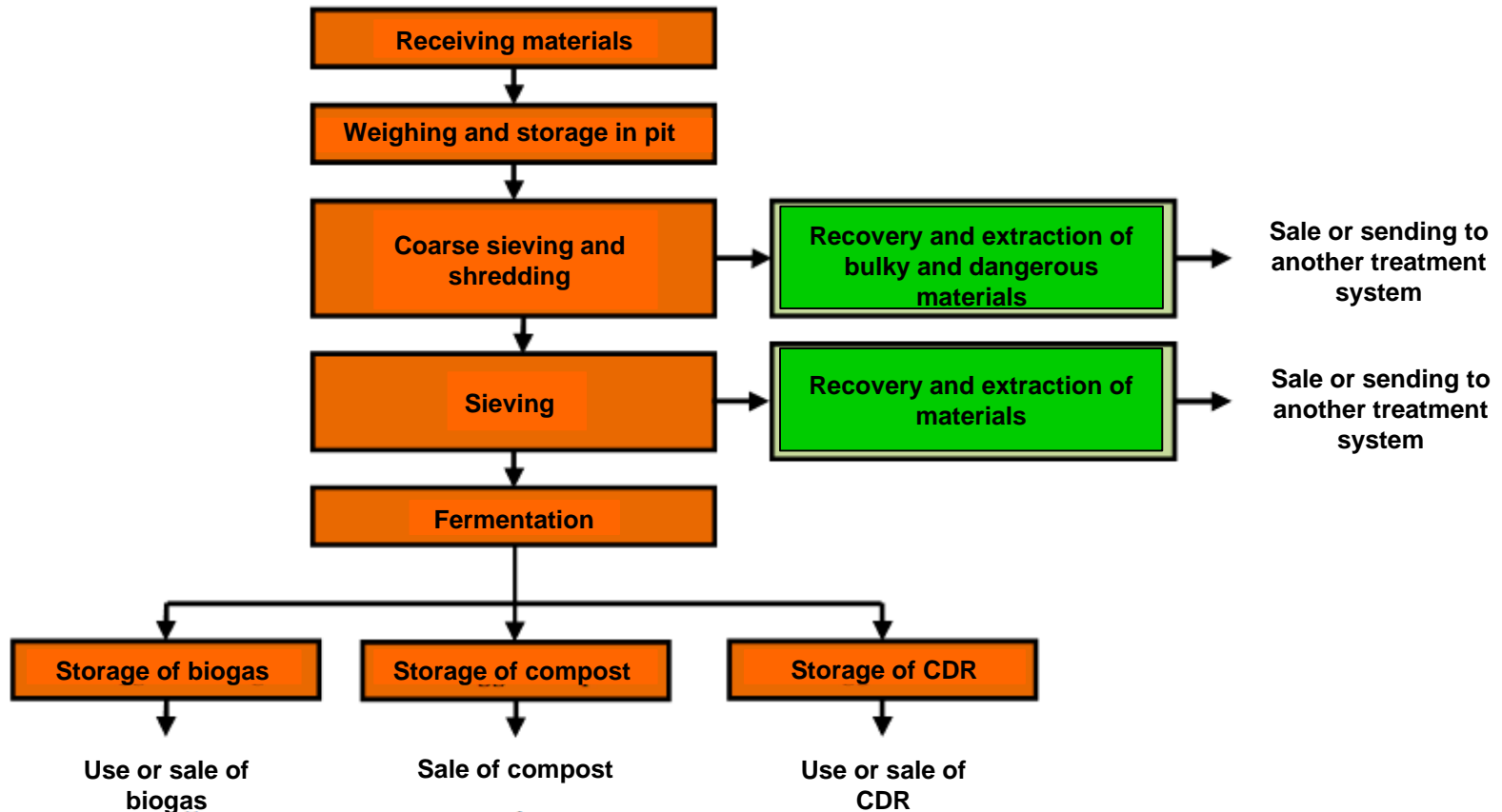

Waste treatment plants

Mechanical-biological treatment of solid waste

Such high technology systems employ of automatic classification of materials: a technology adopted is that of near to infrared spectroscopy, which allows to detect the different types of plastics and to control a system of jets of compressed air for separation.

Waste treatment plants

Mechanical-biological treatment of solid waste

The plants of mechanical-biological treatment of waste must have the following characteristics:

- the material that has not been separated at the source should be recovered for recycling and the markets should be researched and developed;
- avoid any possible accumulation of potentially toxic elements;
- minimize emissions into the atmosphere even with the use of systems of biofilters and "scrubbing" (washing) or to the combined use of thermal systems to clean the exhaust gases from materials of biological origin (carbon dioxide, methane, ammonia etc.);
- minimize emissions to soil and water trying to have the minimum impact on human health and the environment;
- minimize the exposure of employees in handling materials and dell'emissioni of various operational phases;
- minimize waste and their toxicity.

Waste treatment plants

Mechanical-biological treatment of solid waste

This plant exhibits considerable potential, as it offers a treatment that:

- has high performance in environmental terms;
- shows a limited visual unpleasantness;
- can run on relatively small scales, with no significant diseconomies of scale;
- has of the costs competitive given the low emissions and the positive environmental features.

Waste treatment plants

Mechanical-biological treatment of solid waste

The costs of processing include:

- planting costs related to the acquisition of the areas, the construction of buildings, the paving of the areas of aging and storage, machinery, infrastructure etc.;
- operating costs, including staff salaries, maintenance of machinery, energy consumption and overhead of enterprise;
- costs arising from operations incidental to start up at other treatments the fraction not compostable.

Waste treatment plants

Solid waste incineration

The **incinerators** are plants mainly used for the disposal of solid waste through a process of high-temperature combustion, which gives as final products a gaseous effluent, ashes and dusts.

In the most modern plants, the heat present in the flue gases, which develop during the combustion of waste, is recovered and used to produce superheated steam, then used in a turbine coupled to an electric motor value for the production of electricity or as vector heat (for example for district heating). These systems with technologies for the recovery are indicated by the name of **incinerators with energy recovery** or **waste to energy plants**.

Waste treatment plants

Solid waste incineration

The purpose of this system, which has the advantage of requiring an industrial area of less than equal treatment capacity and to determine a greater reduction in volume of the treated waste, is to destroy their potential pollution, burning organic substances and mineralizing inorganic substances contained therein.

Incineration should be considered only after careful examination of the nature and quantity of waste to be eliminated. This disposal system can present considerable drawbacks during the year, such as air pollution and corrosion phenomena and, in any case, given its destructive action of the solid waste treated, except for the systems with energy recovery, is resolved with a depletion of resources.

Waste treatment plants

Solid waste incineration

The flow diagram of a plant for incineration with energy recovery is presented in Figure

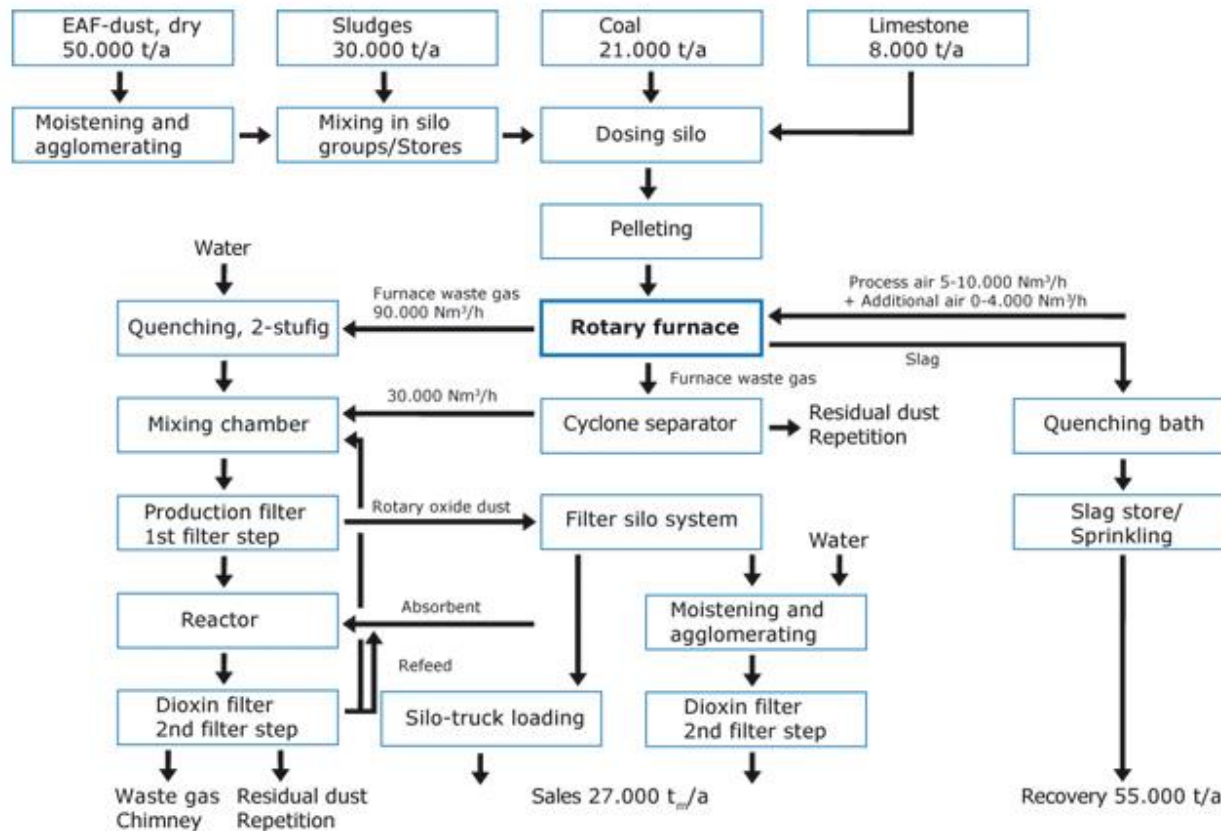

Waste treatment plants

Solid waste incineration

The three-dimensional representation of a plant for incineration with energy recovery is presented in Figure.

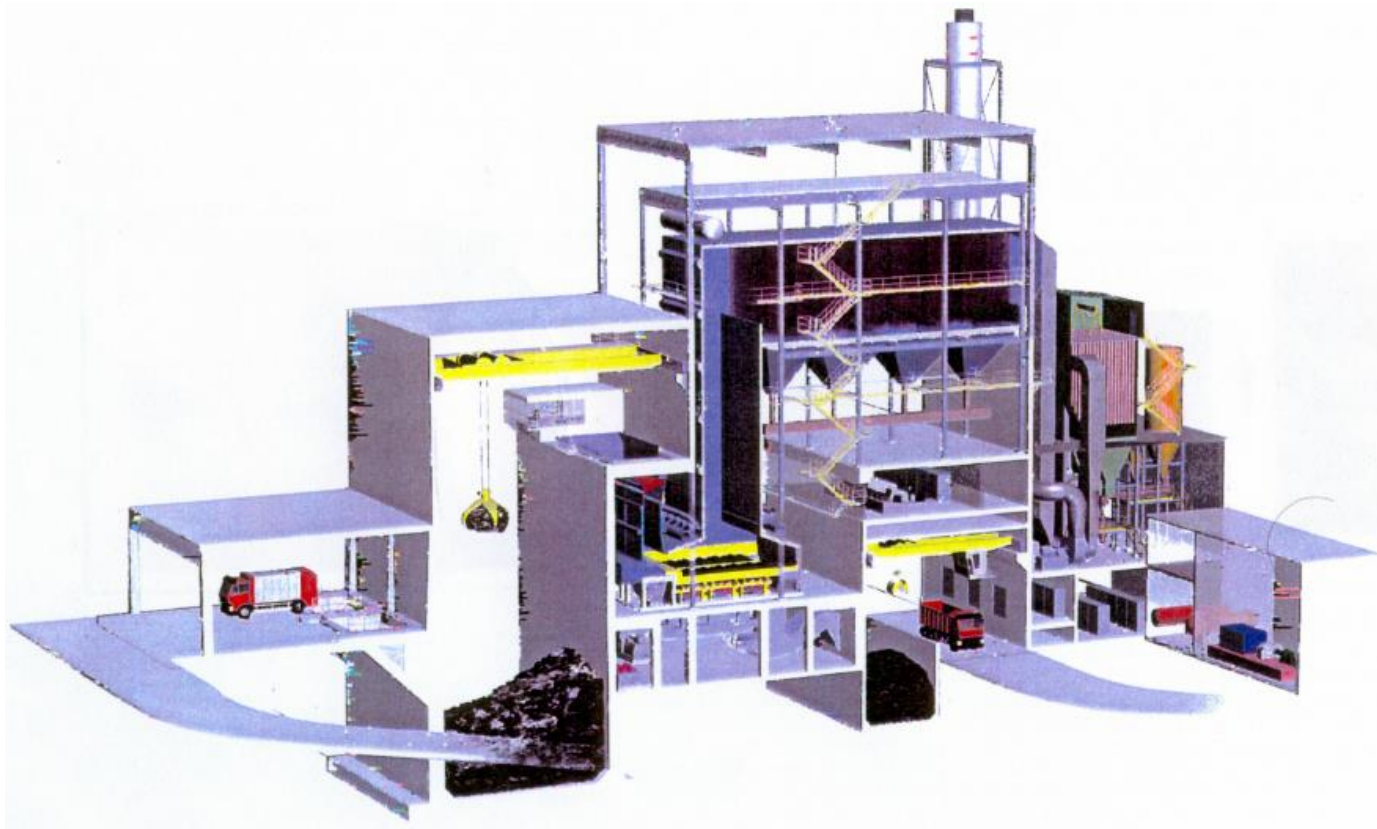

Waste treatment plants

Solid waste incineration

The operation of a "waste to energy plant" can be divided into a few basic steps:

a) *arrival and storage of waste*

From installations of selection, but also directly from the collection, the waste enters the air plant by truck and are weighed. Subsequently the trucks head in the foredeep, where you maneuver the discharge of waste in the storage pit in positions where appropriate exhaust are positioned closing to clapet of complete braking system and lights (Figures)



Waste treatment plants

Solid waste incineration

The operation of a "waste to energy plant" can be divided into a few basic steps:

a) *arrival and storage of waste*

The pit must be completely waterproofed.

After the operation of unloading has the washing of the vehicles and the subsequent weighing of these output in order to evaluate the amount of waste sent to the system.

The pit of reception is in depression to prevent the disperse odors and the sucked air is sent into the oven combustion (primary combustion air), and its capacity must be sufficient to containing the waste collected during 3-6 days in order to allow a range of operation of 72-144 hours.

Waste treatment plants

Solid waste incineration

The operation of a "waste to energy plant" can be divided into a few basic steps:

a) *arrival and storage of waste*

The handling of the waste from the pit to the feed hopper of the oven is carried out using a crane with polyp grab moved by a crane operator, positioned in a suitable conditioned cabin in such a way as to have visibility on the pit and on the feed hopper.

The technology of production of the fuel fraction (CDR) and its incineration exploits the prior dehydration of organic waste followed by separation of the inert materials (metals, minerals etc.) from the fuel fraction, which can be burned, producing electricity with a better yield compared to classical incineration and with a reduction of environmental impact.

Waste treatment plants

Solid waste incineration

The operation of a "waste to energy plant" can be divided into a few basic steps:

b) feeding and combustion of the waste in the oven

The feed hopper is the element of transition between the pit of receipt of the waste and the oven; it presents a particular form to avoid the formation of "bridges of material" and is powered directly from the bridge crane of the pit of waste storage (Figure)

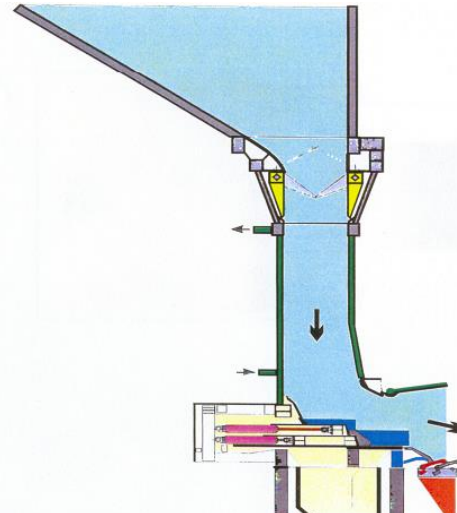

Waste treatment plants

Solid waste incineration

The operation of a "waste to energy plant" can be divided into a few basic steps:

b) feeding and combustion of the waste in the oven

The connection to the oven takes place through a loading duct, which widens gradually from the hopper until the entry into the combustion chamber. This duct is cooled by a water jacket and is always full of waste in operation in order to ensure the seal between the interior of the combustion chamber and the exterior, thus preventing the entry of air. To control the level of waste is placed an indicator in the conduit connected with the control cabin of the bucket.

Waste treatment plants

Solid waste incineration

The operation of a "waste to energy plant" can be divided into a few basic steps:

b) feeding and combustion of the waste in the oven

Between the base of the hopper and the mouth of the duct is placed a valve to clapet hydraulically operated, and closed in case of fire of the waste that prevents fire from spreading to the pit. From the loading duct the waste is pushed into the combustion chamber from a feeder piston hydraulically actuated at variable speed, to ensure a uniform distribution of the waste on the grid.

Waste treatment plants

Solid waste incineration

The operation of a "waste to energy plant" can be divided into a few basic steps:

b) feeding and combustion of the waste in the oven

The oven is usually equipped with one or more mobile grills (oven to "grid"). The handling and the advancement of the waste on the grid are due to the movement of the fire bars, elements made of hollow plates, alternately fixed and mobile, which constitute the flat surface of the grid of the oven (Figures).

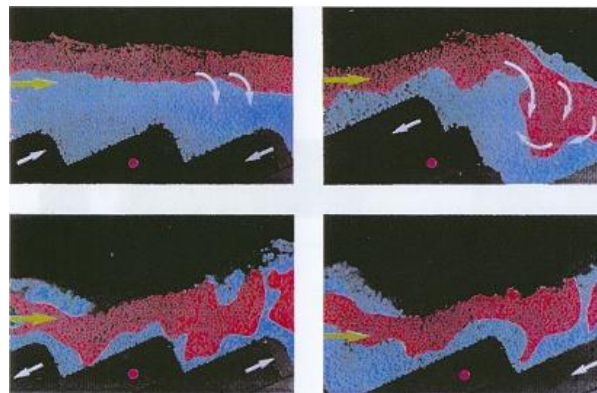
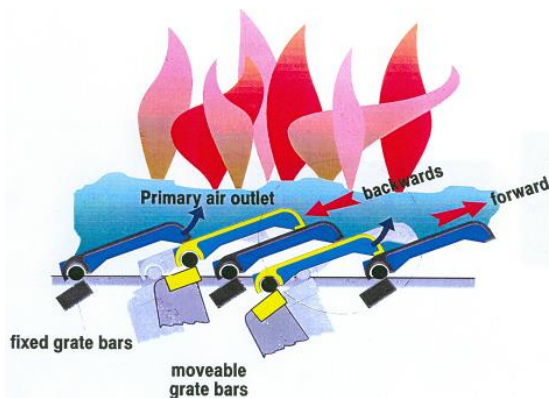

Waste treatment plants

Solid waste incineration

The operation of a "waste to energy plant" can be divided into a few basic steps:

b) feeding and combustion of the waste in the oven

The speed of the grid and the amplitude of the stroke of the fire bars are varied and graduated depending on the type of combustion and each grid element is provided with independent control to adjust the frequency and stroke.

The movement of the fire bars revolt and advances waste facilitating full contact with the combustion air, also carries the heavier parts (slag and ash) to the lower strata in contact grid and lighter materials, which have yet to burn toward higher layers.

Waste treatment plants

Solid waste incineration

The operation of a "waste to energy plant" can be divided into a few basic steps:

b) feeding and combustion of the waste in the oven

With this type of grid the ignition process takes place not only by radiation and contact with the hot smoke, but outbreaks of material in combustion are conveyed continuously under the layer of fuel.

The use of fuel from waste with high calorific value due to the overheating of the grid itself, with possible merger of radioactive and corrosive attack of molten slag to the fire bars. To overcome this drawback we adopt the cooling water of the grid, with an extension of the 2/3 of the grid in the area covered by the flame and which consists in the passage of the fluid inside the cavities of those fire bars most stressed thermally.

Waste treatment plants

Solid waste incineration

The operation of a "waste to energy plant" can be divided into a few basic steps:

b) feeding and combustion of the waste in the oven

Air cooling is nevertheless present and justified for the zone less hot grill. Although the size of the water-cooled grate bars are greater than those air-cooled, the advantages that are obtained are less wear and dilation of the fire bars, but also the possibility of reducing the air flow subgrid. In this way there is a staged combustion with air introduced in a quantity slightly sub-stoichiometric with the consequent reduction of the formation of NO_x in the flue gas. The residence time of the fuel on the grid is a function of the frequency of the movement of the fire bars, and depends on the capacity of the combustion, the composition and quality of the material to be treated.

Waste treatment plants

Solid waste incineration

The operation of a "waste to energy plant" can be divided into a few basic steps:

b) feeding and combustion of the waste in the oven

The oxidation process in the combustion chamber can be summarized in three phases that characterize also the division of the grid in four zones:

- a) drying zone (dehumidification and power);
- b) the pyrolysis zone, with transformation of the organic fraction in CO_2 , H_2O and various compounds to be reduced volatile solids;
- c) the main area of combustion;
- d) final combustion zone (complete combustion of the waste).

Waste treatment plants

Solid waste incineration

The operation of a "waste to energy plant" can be divided into a few basic steps:

b) feeding and combustion of the waste in the oven

A current of forced air is inserted in the oven to make the necessary amount of oxygen, which allows the better combustion, while maintaining the high temperature (up to 1000°C for not provoke the plasticization of the glass and its anchorage to the refractory bricks in the course cooling). To maintain these temperatures, where the calorific value of the fuel is too low, it is sometimes entered the methane gas in an amount varying between 4 and 19 m³ per ton of waste, the same fuel that is placed in the start up phase and oven support of through a combustion burner.

Waste treatment plants

Solid waste incineration

The operation of a "waste to energy plant" can be divided into a few basic steps:

b) feeding and combustion of the waste in the oven

The slag end up within a stainless steel tank containing water (well slag), where it will undergo a process of cooling by evaporation of water present therein; subsequently by means of a suitable device vibrating feeder channel, are sent to the existing collection pit and storage, and removed periodically and send with truck in landfill.

Waste treatment plants

Solid waste incineration

The operation of a "waste to energy plant" can be divided into a few basic steps:

b) feeding and combustion of the waste in the oven

From the grid the amount of fine material that falls between the fire bars is reduced to a minimum (0.2-0,5 kg/t incinerated), is conveyed in the binders and removed from a chain conveyor toward the well slag (Figure)

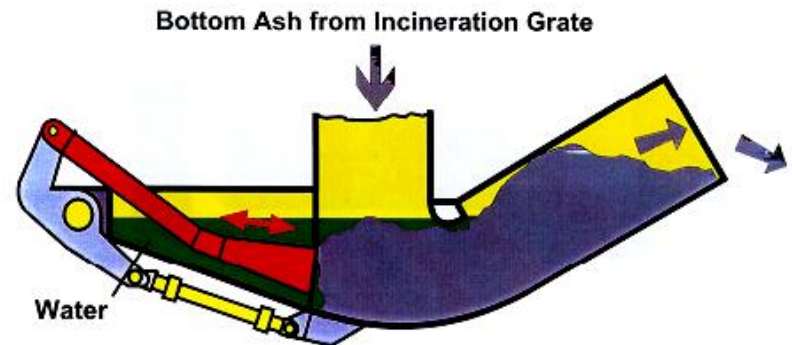
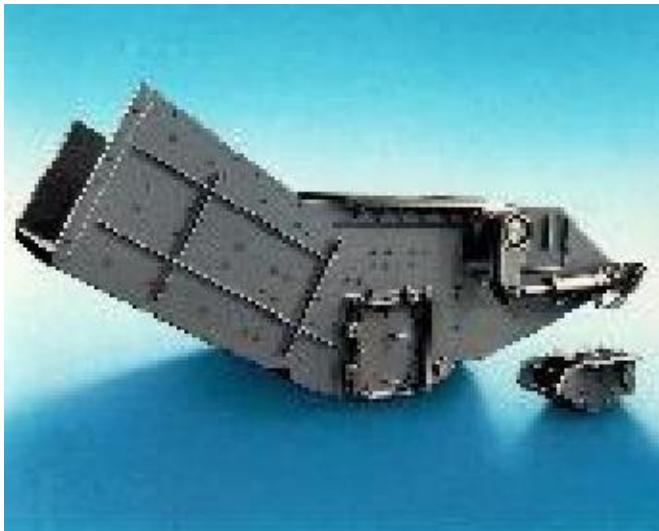

Waste treatment plants

Solid waste incineration

The operation of a "waste to energy plant" can be divided into a few basic steps:

b) feeding and combustion of the waste in the oven

The primary air is blown sub-grid controlled by a damper for adjusting the flow according to the needs of the various zones. The primary air is sucked out of the pit of receipt of the waste. It is provided that it can be preheated in a separate heat exchanger.

The secondary air is injected at high pressure into the combustion chamber above the bed of waste in order to increase turbulence, complete the combustion of the gas and control the temperature. There is also a fan which has the function of cooling the power supply and the side walls of the grid.

Waste treatment plants

Solid waste incineration

The operation of a "waste to energy plant" can be divided into a few basic steps:

b) feeding and combustion of the waste in the oven

The walls of the combustion chamber are lined inside them from boiler tubes connected to the cylindrical body of the boiler itself; have the function to maintain the low temperature of the refractory and to avoid the oxidation of the silicon carbide and the adhesion of the slag. This will ensure a greater cleaning and then a maintenance task easier as well as an increase in the efficiency of combustion.

Waste treatment plants

Solid waste incineration

The operation of a "waste to energy plant" can be divided into a few basic steps:

b) feeding and combustion of the waste in the oven

The process is therefore a treatment of thermal degradation in oxidative conditions (combustion), aimed at:

- completely oxidize the material into CO₂ and H₂O and having a solid residue of a purely inorganic (oxides of various metals contained in the waste, silica, carbonates, various salts) so that the reaction of the passage of the waste products is exothermic

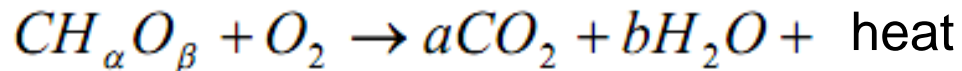

- reduce the weight and volume of the material (30% of initial weight and 10% of the initial volume);
- recover the energy content of the waste (calorific value);
- sterilize the inert residue (slag).

Waste treatment plants

Solid waste incineration

The operation of a "waste to energy plant" can be divided into a few basic steps:

b) feeding and combustion of the waste in the oven

For the qualitative characteristics of waste currently produced, the combustion process is self sustaining, thus not requiring the use of fossil fuel support.

The active phenomena are attributable to:

- fuel elements (C, H, S), which generate the final products such as oxidized CO₂, H₂O and SO₂;
- moisture, which leads to evaporation of H₂O;
- aggregates, which are found in the slag;
- metals, which produce the phenomena of volatilization, depending on the temperature and its type;
- the halogens (Cl, F, Br) that generate halo acids (for example: $\text{Cl} + 0,5 \text{H}_2\text{O} \rightarrow \text{HCl} + 0,25 \text{O}_2$);

Waste treatment plants

Solid waste incineration

The operation of a "waste to energy plant" can be divided into a few basic steps:

b) feeding and combustion of the waste in the oven

For the qualitative characteristics of waste currently produced, the combustion process is self sustaining, thus not requiring the use of fossil fuel support.

The active phenomena are attributable to:

- nitrogen present in both the refusal is in the air, which generates NO_x;
- complex phenomena of formation and destruction of trace organic compounds (for example, the generation of dioxins).

Dioxins are a class of heterocyclic organic compounds whose basic structure consists of a ring with 4 C atoms and 2 O₂. Are divided into two categories, both derived from compounds of formula C₄H₄O₂. Most of polyhalogenated dioxins are persistent organic pollutants such as polychlorinated or PCDD or PCDF and polychlorinated. In everyday language, then, are referred to as dioxins also compounds derived from furan, particularly dibenzofurans. Dioxins are formed mainly between 400 and 800°C, and that's why we work with temperatures around the 950-1000°C; high combustion efficiency lowers the amount of organic compounds necessary for their formation.

Waste treatment plants

Solid waste incineration

The operation of a "waste to energy plant" can be divided into a few basic steps:

b) feeding and combustion of the waste in the oven

Among the grate (Figure) there are two types (fixed or mobile) even though the most common ones are those mobile grid since the movement allows for a better mixing of the waste and a more complete combustion for the best contact with the air.



Waste treatment plants

Solid waste incineration

The operation of a "waste to energy plant" can be divided into a few basic steps:

b) feeding and combustion of the waste in the oven

For the grate has the following design parameters:

- thermal load on the grate from 0,47-0,94 MW/m²;
- thermal load volume of 0,07-0,24 MW/m³;
- load weight on the grid 200-350 kg/m³;
- residence time of the waste 30-60 minutes;
- residence time of 2-6 seconds fumes.

Waste treatment plants

Solid waste incineration

The operation of a "waste to energy plant" can be divided into a few basic steps:

b) feeding and combustion of the waste in the oven

The operating conditions of this oven types are:

- operating temperature of 850-900°C so as not to obtain the fusion of the ash;
- energy efficiency 20-60% depending on if you retrieve only electricity or thermal energy;
- excess air: 70-100%.

Waste treatment plants

Solid waste incineration

The operation of a "waste to energy plant" can be divided into a few basic steps:

b) feeding and combustion of the waste in the oven

If the waste to be treated contains material of variable nature and content of difficult incineration (vegetables, pieces of wood, certain types of paper) and if the humidity of the same waste is subject to constant and rapid changes in the best solution is that of rotary kiln, which is commonly used for industrial waste, and which has an inclination of about 11° (Figure)



Waste treatment plants

Solid waste incineration

The operation of a "waste to energy plant" can be divided into a few basic steps:

b) feeding and combustion of the waste in the oven

The waste with these features require residence times in the apparatus of combustion which vary from one to three and a half hours.

A plant designed grid can treat these wastes only with great difficulty. The area of the grid must be designed to meet the characteristics of the medium in its most wastes. An implant can also be forced to work, for some periods, with reduced loads and with a lower level of quality of the effluvia.

Waste treatment plants

Solid waste incineration

The operation of a "waste to energy plant" can be divided into a few basic steps:

b) feeding and combustion of the waste in the oven

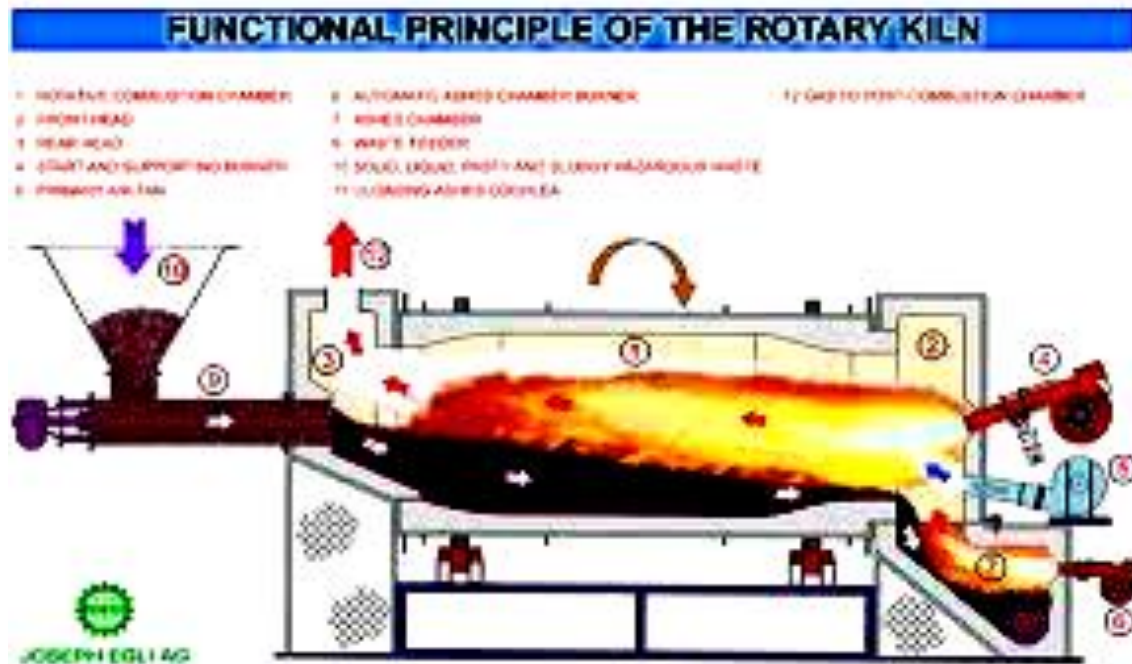

Waste treatment plants

Solid waste incineration

The operation of a "waste to energy plant" can be divided into a few basic steps:

b) feeding and combustion of the waste in the oven

The rotary kiln is generally capable of increasing the residence time considerably and exposes the waste to a strong impact with a high-temperature environment and very rich in oxygen. The result is a residue with a small content of fuel gas and putrescible material.

The essential merit lies in the fact that the combustion develops in homogeneous conditions, it is easy to verify by an examination of the residual waste, and the value of the ratio $\text{CO}_2/(\text{CO}_2+\text{CO})$ reater than 99.9%. It follows that the basic result in the emission concentrations of organochlorine micropollutants (PCDD and PCDF) are always much lower than the limits prescribed by the regulations.

Waste treatment plants

Solid waste incineration

The operation of a "waste to energy plant" can be divided into a few basic steps:

b) feeding and combustion of the waste in the oven

May be of the type:

- against the current

Applied to municipal solid waste and on those hospital, offers a great flexibility and stability of operation, mainly due to the presence of a grid which allows the inner rotary complete oxidation of the combustion products;

Waste treatment plants

Solid waste incineration

The operation of a "waste to energy plant" can be divided into a few basic steps:

b) feeding and combustion of the waste in the oven

May be of the type:

- equicurrent

It is directed to industrial waste, toxic waste and hospital with high calorific value and is designed to treat simultaneously also solid, liquid high and low calorific value, shoveled mud and pumpable. The co-current rotary kiln is designed and employs materials for very high temperature combustion, such as to have the drain liquid from the residual ash.

Waste treatment plants

Solid waste incineration

The operation of a "waste to energy plant" can be divided into a few basic steps:

b) feeding and combustion of the waste in the oven

For the rotating drum ovens have the following design parameters:

- diameter 1.5-4 m;
- length 8-15 m;
- length/diameter ratio 2-5;
- heat load surface 0,6-1,2 MW/m²;
- volumetric thermal load from 0,1-0,24 MW/m³;
- temperature of the kiln jacket 100-300°C;
- residence time of the waste 0.5-1 h;
- heat loss 10%.

Waste treatment plants

Solid waste incineration

The operation of a "waste to energy plant" can be divided into a few basic steps:

b) feeding and combustion of the waste in the oven

The operating conditions of this oven types are:

- 100-150% excess air;
- 15-16%;
- speed 0.5-1.2 revolutions/minute.



Waste treatment plants

Solid waste incineration

The operation of a "waste to energy plant" can be divided into a few basic steps:

b) feeding and combustion of the waste in the oven

Ovens are very versatile, suitable for disposal of solid waste of various kinds (municipal and industrial), as well as sludge, oily sludge and liquid waste (injected with spears or atomizers leading the drum). The main industrial application is in the field of hazardous waste and various special waste.

Are built in a field of potential variable (from 0.5 to 40 t/h). They are made of steel with a refractory lining. The longitudinal axis is slightly inclined to the horizontal (11°) in order to favor the progress of the waste from the feeding zone to the discharge of the slag.

Waste treatment plants

Solid waste incineration

The operation of a "waste to energy plant" can be divided into a few basic steps:

b) feeding and combustion of the waste in the oven

The high versatility is mainly determined by high mixing of waste and oxygen in the course of slow rotation, the simplicity of the supply system also suitable for bulky waste, the absence of internal metal parts, with consequent possibility to operate also at very high temperatures and the possibility to operate with high retention times, thus promoting the efficiency of combustion.

Beside a **primary combustion** chamber is associated with a **secondary combustion** chamber (afterburning chamber), with the purpose to complete the combustion of the fumes in the best compliance with current regulations..

Waste treatment plants

Solid waste incineration

The operation of a "waste to energy plant" can be divided into a few basic steps:

b) feeding and combustion of the waste in the oven

It is dimensioned to keep the fumes at a higher temperature to 950°C for a time of persistence of at least 2 seconds. In this way it avoids the formation of acidic condensates in flue preventing corrosion phenomena in filtration downstream. It must also comply with the operating values on the oxygen content in the flue gas of at least 6% by volume and the input speed to the same room of at least 10 m/s. The post-combustion chamber is lined with refractory material and the outlet temperature is controlled automatically by acting on the burner and on the air secondary.

Waste treatment plants

Solid waste incineration

The operation of a "waste to energy plant" can be divided into a few basic steps:

b) feeding and combustion of the waste in the oven

The combustion **fluidized bed oven** is obtained by sending from below by a strong jet of air through a bed of sand. The bed then rises, while the particles are mixed and are under continuous agitation (Figure)

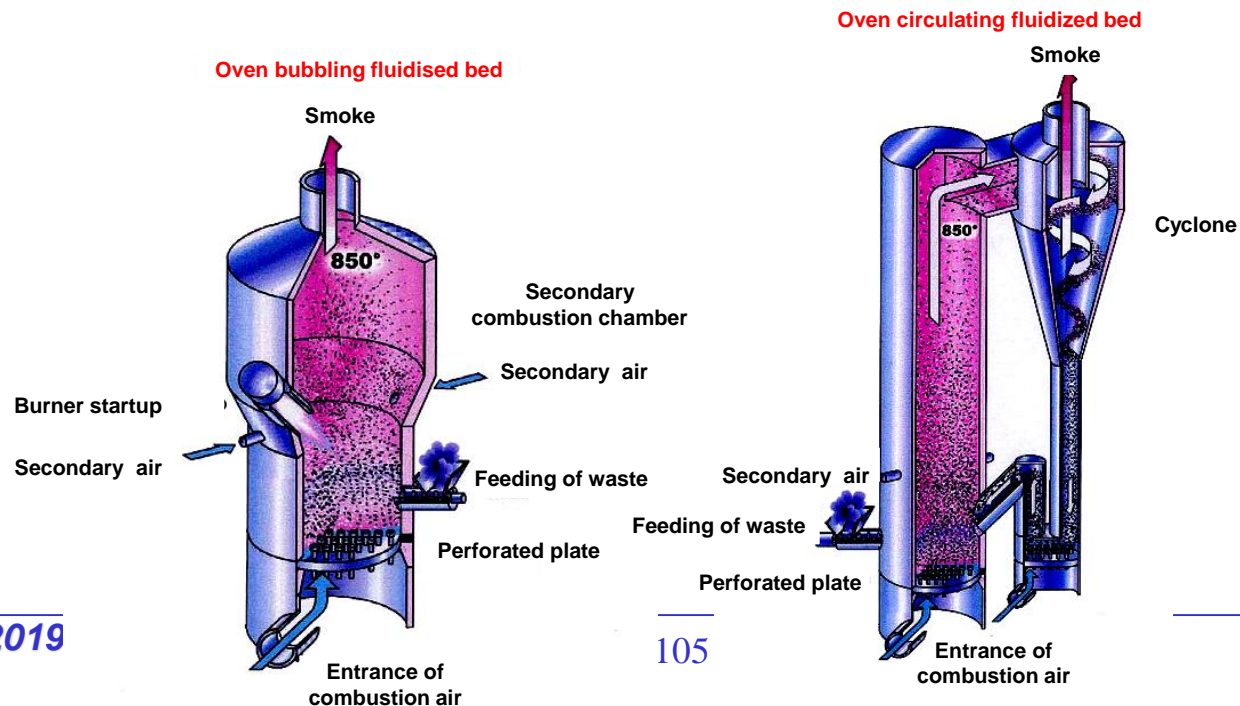

Waste treatment plants

Solid waste incineration

The operation of a "waste to energy plant" can be divided into a few basic steps:

b) feeding and combustion of the waste in the oven

Are then introduced into the waste and the fuel. The system sand/refusal/fuel is kept in suspension on the flow of air and pumped under violent agitation and restlessness, assuming in this way features-like fluid. This process of fluidization has the effect of decreasing the density of the system without altering the original nature. The whole mass of waste, fuel and sand circulates completely inside the oven. The fluid bed technology is commonly used in chemical reactors to implement the chemical synthesis and part of the petrochemical industry.

Waste treatment plants

Solid waste incineration

The operation of a "waste to energy plant" can be divided into a few basic steps:

b) feeding and combustion of the waste in the oven

A combustion chamber fluidized bed allows to reduce the emissions of sulfur oxides (SO_x) by mixing powdered limestone or dolomite to the sand: in this way in fact the sulfur is not oxidized, forming gas, but precipitates in the form of sulfate. This precipitate hot improves the heat exchange for the production of water vapor. Since the fluid bed also allows to operate at lower temperatures (800°C), operating at these temperatures it is possible to reduce the emissions of nitrogen oxides (NO_x).

Waste treatment plants

Solid waste incineration

The operation of a "waste to energy plant" can be divided into a few basic steps:

b) feeding and combustion of the waste in the oven

From the literature shows that by comparing the emissions of particulate matter, characterizing the size, composition and concentration, and trace elements for use of a room in grids and a chamber fluidized bed upstream of the filter systems, it was found that emission of particles with diameter less than 1 μm are approximately four times higher in the case of the grids, with values of 1-1.4 g/Nm^3 against 0.25 to 0.31 g/Nm^3 of the fluid bed. Was also measured the mean total amount of ash produced, which was found to be 4.6 g/Nm^3 in the case of the fluid bed and of 1.4 g/Nm^3 in the case of the grids.

Waste treatment plants

Solid waste incineration

The operation of a "waste to energy plant" can be divided into a few basic steps:

b) feeding and combustion of the waste in the oven

The fluidized bed has the advantage of requiring little maintenance and, given the particular constitution, requires no moving parts. It has a slightly higher yield compared to the grate, but requires fuel-grained rather homogeneous.

The types of fluid bed most exploited mainly fall into two categories: **fluidized bed combustion** and **pressurized fluidized bed combustion**. The latter are able to generate a gas flow at high pressure and temperature capable of powering a gas turbine, which can realize a high-efficiency combined cycle.

Waste treatment plants

Solid waste incineration

The operation of a "waste to energy plant" can be divided into a few basic steps:

b) feeding and combustion of the waste in the oven

Ovens are vertical cylindrical steel coated inside with refractory, containing a bed of hot sand kept in constant fluidization air. The most usual commercial diameters ranging from 2.5 to 8 m, but there are also special versions of over 15 m.

In ovens fluid bed recirculating the speed is higher so as to determine the complete entrainment of dust and sand. The latter is taken up in the furnace outlet in a cyclone and recirculated to the base of the furnace together with a flow of smoke recirculation for the maintenance of the required fluid dynamic conditions.

Waste treatment plants

Solid waste incineration

The operation of a "waste to energy plant" can be divided into a few basic steps:

b) feeding and combustion of the waste in the oven

The sand bed is approximately 0.8 m high and is supported on a refractory base. Through the nozzles in the base fixtures air is injected at 0.2-0.35 bar with a flow rate such as to cause the expansion and the fluidization of the bed up to about 100% of the initial volume at rest.

The temperature in the oven is uniform and is controlled by means of burners located at different heights. In some installations the temperature control is effected with the aid of water injections.

Waste treatment plants

Solid waste incineration

The operation of a "waste to energy plant" can be divided into a few basic steps:

b) feeding and combustion of the waste in the oven

The retention time of the smoke is limited to a few seconds, however, sufficient for complete combustion due to the high contact surface of smoke/rejection. The ashes are carried by exhaust smoke and are cleared with classic dedusting systems (wet or dry scrubbers).



Waste treatment plants

Solid waste incineration

The operation of a "waste to energy plant" can be divided into a few basic steps:

b) feeding and combustion of the waste in the oven

A sand fraction is dragged with smoke and therefore must be periodically replaced. It is estimated a loss of sand by 5% every 300 hours of operation.

The intense complete mixing of sand, air and waste determines good and uniform conditions of heat exchange and combustion. For this reason, the excess of air, for this type of furnace, is generally maintained in the range 30-45%.

Waste treatment plants

Solid waste incineration

The operation of a "waste to energy plant" can be divided into a few basic steps:

b) feeding and combustion of the waste in the oven

The hot sand bed acts as a lung heat, which allows the leveling of any tendency of fluctuation of the temperature in relation to power supply variables. This ability to act as a thermal flywheel also allows easy restarts after relatively short periods of shutdown.

The power of any auxiliary fuel is controlled automatically by measuring the temperature of exhaust smoke.

The major problems of exercise of the fluid bed furnaces relate to the supply system of the refusal, where occlusions may occur due to the feeding of sludge too dense or due to local excessive drying.

Waste treatment plants

Solid waste incineration

The operation of a "waste to energy plant" can be divided into a few basic steps:

b) feeding and combustion of the waste in the oven

Other problems may relate to the effects of erosion or fouling along the line smoke (air pre-heater with the hot fumes, boiler etc.) because of the sand and ashes drag.

The fluid bed furnace for their particular construction (absence of internal metal bodies), have the advantage of being able to operate up to temperatures of 1200°C; therefore are also suitable for sludge and high calorific CDR.

Waste treatment plants

Solid waste incineration

The operation of a "waste to energy plant" can be divided into a few basic steps:

b) feeding and combustion of the waste in the oven

In general, however, you try not to exceed temperatures of 1050°C to avoid side effects (fusion ashes, corrosion, formation of clinker etc.), Related to the quality of waste to be incinerated.

The sensible heat of the smoke can be recovered with the production of high pressure steam in the recovery boiler and subsequent expansion in the turbine for the production of electricity. The adoption of this recovery scheme is applied only to very high potentials.

Waste treatment plants

Solid waste incineration

The operation of a "waste to energy plant" can be divided into a few basic steps:

b) feeding and combustion of the waste in the oven

The bubbling fluidized bed furnace has the following advantages:

- high rates of heat transfer;
- easy temperature control;
- fairly uniform temperature distribution;
- size and composition of the burden of waste variables;
- high ash content permissible;
- high volumetric capacity, resulting in a smaller footprint of the oven.

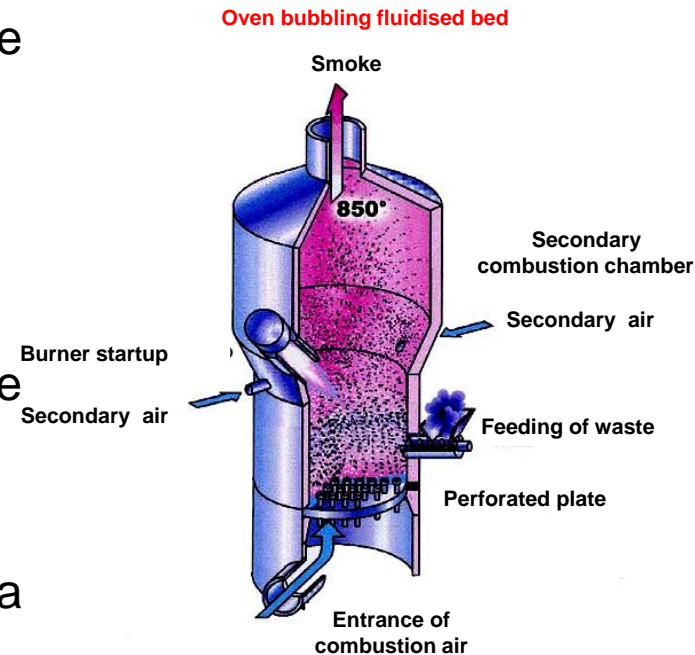

Waste treatment plants

Solid waste incineration

The operation of a "waste to energy plant" can be divided into a few basic steps:

b) feeding and combustion of the waste in the oven

The oven bubbling fluidised bed has the following disadvantages:

- operating temperature limited by the solidification of ashes;
- high temperature flue gas products.

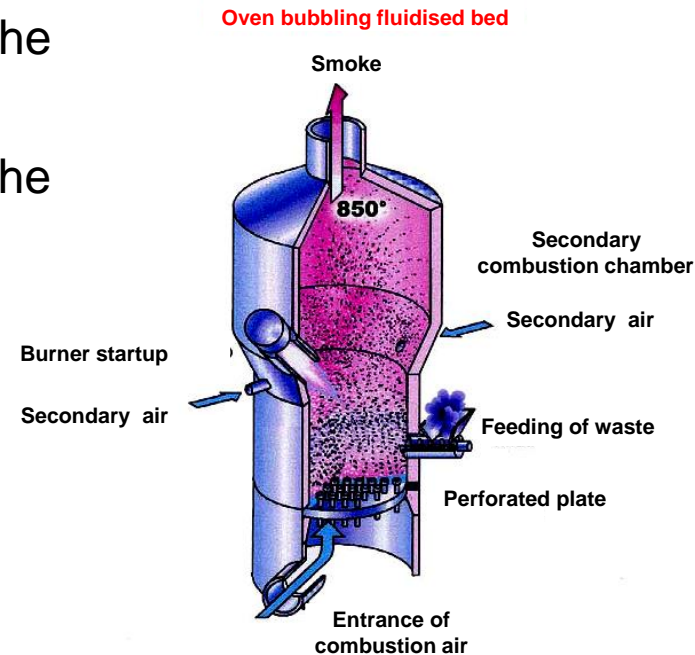

Waste treatment plants

Solid waste incineration

The operation of a "waste to energy plant" can be divided into a few basic steps:

b) feeding and combustion of the waste in the oven

The recirculating fluidized bed furnace has the following advantages:

- residence time high;
- greater turbulence resulting in conversion efficiency.

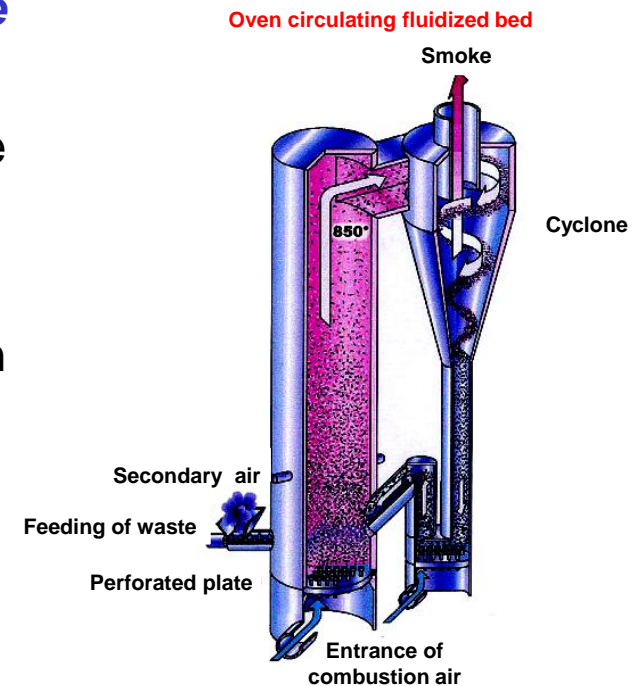

Waste treatment plants

Solid waste incineration

The operation of a "waste to energy plant" can be divided into a few basic steps:

b) feeding and combustion of the waste in the oven

The recirculating fluidized bed furnace has the following disadvantages:

- the waste must have a particle size smaller than those in the fluid boiling;
- the system needs its separate units: the oven and the cyclone separator;
- erosion due to the sustained movement necessary to avoid temperature gradients in the direction of the flow of solid material;
- low volumetric capacity, which involves a greater overall dimensions of the oven.

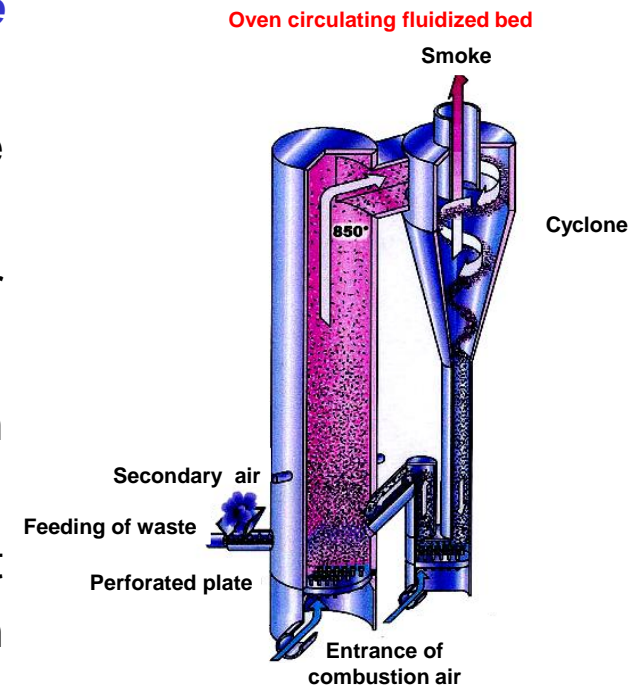

Waste treatment plants

Solid waste incineration

The operation of a "waste to energy plant" can be divided into a few basic steps:

b) feeding and combustion of the waste in the oven

For fluid bed furnaces have the following design parameters:

- velocity of fluidization 2-4 m/s for those bubbling fluidized bed and 5-10 m/s for those in the recirculating fluidized bed;
- 10-50 MW heat load for those bubbling fluidized bed and 40-80 MW for those in the recirculating fluidized bed;
- thermal load volume of 0.18 to 0.24 MW / m³;
- thermal load per unit section in the combustion chamber 1-2.5 MW/m²;
- residence time of the waste 50-90 minutes;
- residence time of the smoke of more than 3 seconds.

Waste treatment plants

Solid waste incineration

The operation of a "waste to energy plant" can be divided into a few basic steps:

b) feeding and combustion of the waste in the oven

The operating conditions of this furnace types are:

- 30-40% excess air;
- operating temperature of 850-900°C;
- energy efficiency 23-25%.

Waste treatment plants

Solid waste incineration

The operation of a "waste to energy plant" can be divided into a few basic steps:

c) *treatment of the slags*

The slag in output from the combustion furnace are subjected to the treatment of iron removal and subsequently sent to the storage pit of the slag of a certain volume.

The process of iron removal consists in the elimination of metallic materials present in the slag, which must have a percentage of unburned putrescible less than 2% by weight of the dry slag (EAWAG method), a value that indicates a complete combustion of the waste.

For the determination of the ash weigh 3-4 g \pm 0.1 mg of sample and transfer in capsule or spacecraft platinum or porcelain, previously calcined at 1000°C until constant weight. It heats the crucible on a small Bunsen burner flame until the end of the development of smoke, then it is placed in a muffle furnace at 1000°C for two hours and finally, after cooling in a desiccator, weigh. It determines the percentage content by mass of ash splits this mass of ash to the mass of the sample

Waste treatment plants

Solid waste incineration

The operation of a "waste to energy plant" can be divided into a few basic steps:

c) treatment of the slags

The output material directly from the discharge end of the extractor on a vibrating table before it disintegrates, as it is compacted by gravity during the dripping. In this way they become available at the overband metallic materials of coarse dimensions that are separated and subsequently discharged through a chute in the appropriate containers.

Waste treatment plants

Solid waste incineration

The operation of a "waste to energy plant" can be divided into a few basic steps:

c) *treatment of the slags*

There is a subsequent disintegration with a second vibrating table to highlight metallic materials of more minute size (Figure)

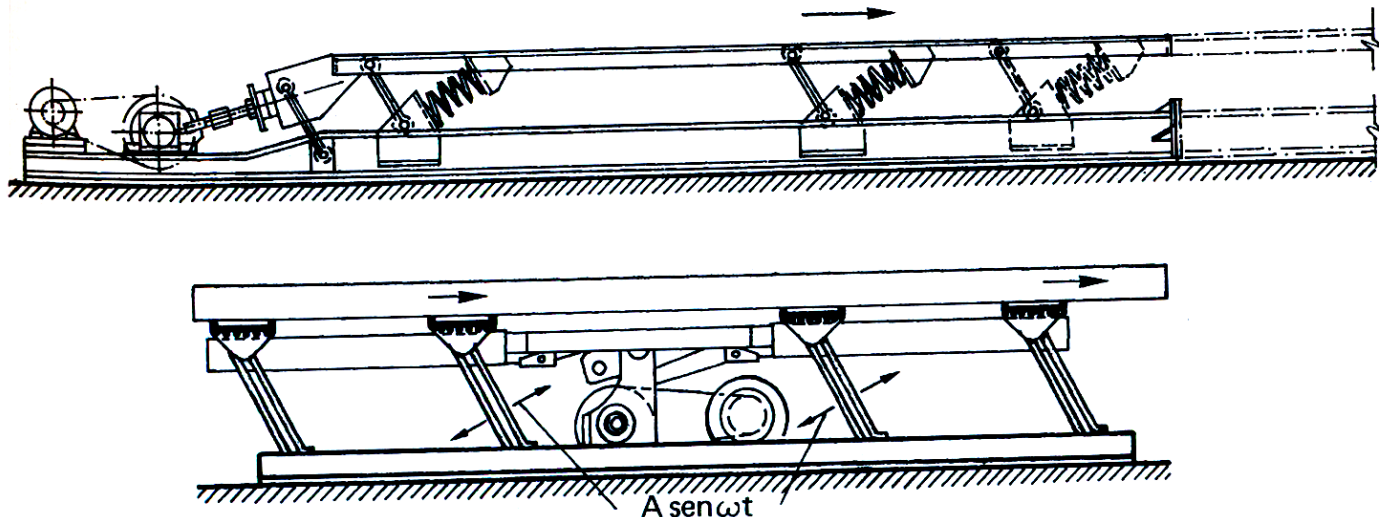

Vibrating conveyors to resonance

Waste treatment plants

Solid waste incineration

The operation of a "waste to energy plant" can be divided into a few basic steps:

c) *treatment of the slags*

The presence of a deferizzatore tape of the magnetic type (Figure), located before the entrance to the pit of the waste, separating the metallic materials purposes and downloads them laterally in a conveyor belt which removes them by depositing them in a demountable container for disposal site appropriate.

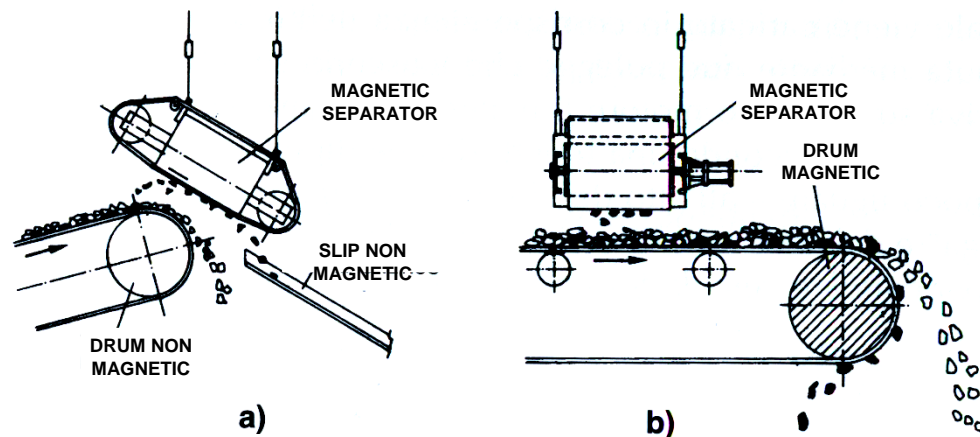

Magnetic separators

Waste treatment plants

Solid waste incineration

The operation of a "waste to energy plant" can be divided into a few basic steps:

d) thermal recovery of smokes

It adopts a boiler water pipes with natural circulation, integrated with the oven. Can be formed by a vertical channel made with membrane walls, constituting the post-combustion chamber of the furnace, and a horizontal channel containing the convective tube bundles pendants for evaporation, overheating and the preheating of the feed water of the economizer.

Waste treatment plants

Solid waste incineration

The operation of a "waste to energy plant" can be divided into a few basic steps:

d) thermal recovery of smokes

In the Figure one can clearly see the structure of a generator and the temperature distribution in its interior.

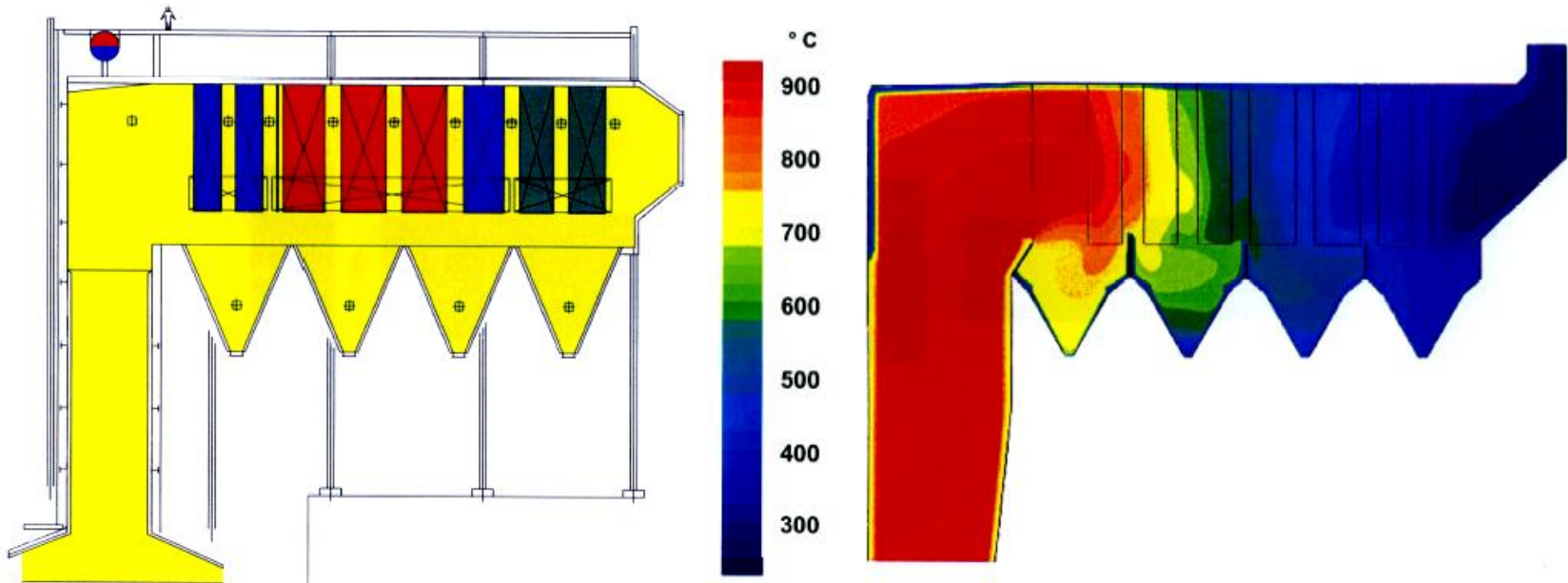

Waste treatment plants

Solid waste incineration

The operation of a "waste to energy plant" can be divided into a few basic steps:

d) thermal recovery of smokes

The boiler is equipped with a cleaning system percussive that allows to achieve a higher efficiency compared to a traditional system with steam blowers (Figure)



Waste treatment plants

Solid waste incineration

The operation of a "waste to energy plant" can be divided into a few basic steps:

d) thermal recovery of smokes

In the phase of generation of steam, the boiler takes place in a first gas treatment, which consists either of urea in the same controlled in order to reduce the NO_x concentration.

To control the temperature of the fumes is provided a system that allows to preheat the incoming feed water economizer keeping constant, to the design values, the temperature of the smoke leaving the boiler; will, however, ensure sufficiently high temperatures as not to cause corrosion economizer same.

Waste treatment plants

Solid waste incineration

The operation of a "waste to energy plant" can be divided into a few basic steps:

d) thermal recovery of smokes

The oven control is done through a computerized control system that allows you to:

- limit the fluctuations of the flow rate of the steam produced by the boiler and sent to the turbine;
- maintain a design value of the oven temperature, the excess of O₂ and CO content in the flue gas.

The control is done by acting on the following variables:

- quantity of waste (feeder speed);
- extent and distribution of the primary air;
- secondary air flow;
- speed and range of movement of the fire bars of the grid.

Waste treatment plants

Solid waste incineration

The operation of a "waste to energy plant" can be divided into a few basic steps:

e) *energy recovery with electricity production*

This section of the system provides the production of electrical energy and thermal energy by sending it to the users by means of a district heating network.

Waste treatment plants

Solid waste incineration

The operation of a "waste to energy plant" can be divided into a few basic steps:

e) *energy recovery with electricity production*

This section includes the following elements:

- condensation turbine with bleed to cover the requirements of vapor getter (Figures);

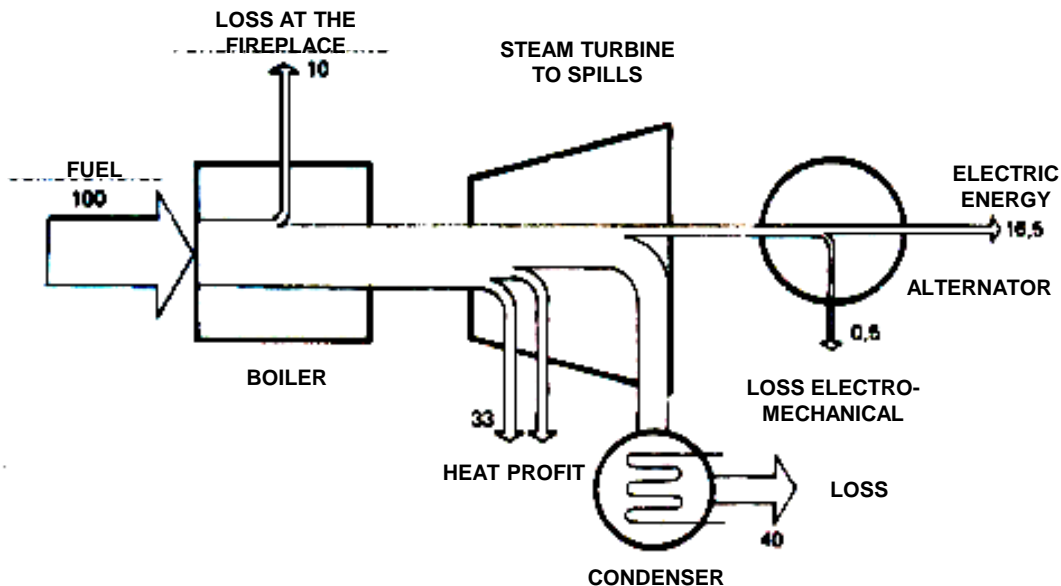

Waste treatment plants

Solid waste incineration

The operation of a "waste to energy plant" can be divided into a few basic steps:

e) *energy recovery with electricity production*

This section includes the following elements:

- three-phase synchronous alternator capable of generating a specific electrical power to the terminals;
- water-cooled condenser for the condensation of the steam turbine to a specific pressure corresponding to a condensing temperature;
- tank for collecting the condensate pumps equipped with extraction for the return of the condensate to the degasser;

Waste treatment plants

Solid waste incineration

The operation of a "waste to energy plant" can be divided into a few basic steps:

e) *energy recovery with electricity production*

This section includes the following elements:

- auxiliary condenser water with pumps of extraction (Figure)

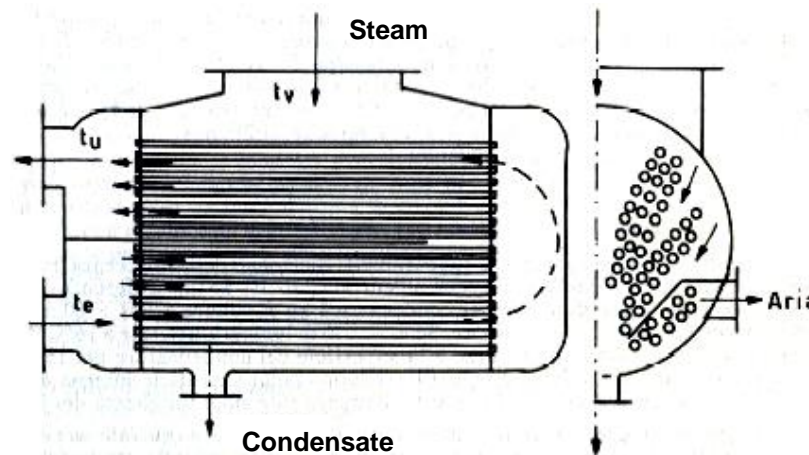

- group of the vacuum ejectors;

Waste treatment plants

Solid waste incineration

The operation of a "waste to energy plant" can be divided into a few basic steps:

e) *energy recovery with electricity production*

This section includes the following elements:

- degasser both for heating water to be fed to the boilers, both for the reduction of the content of O₂.

It consists of a turret of degassing superimposed to a storage tank. The boiler feed water is fed into the top of the turret through a system of spray nozzles and falls on a series of perforated trays in the fractionation of small particles.

Waste treatment plants

Solid waste incineration

The operation of a "waste to energy plant" can be divided into a few basic steps:

e) energy recovery with electricity production

This section includes the following elements:

- degasser

The steam heating salt from the bottom, flowing alternately towards the center and towards the outside of the turret, and then always in the opposite direction to the water flow. The mechanical fractionation of the water in the passage from one plate to another, coupled with the effect of the dynamic and thermal steam, determines the reduction of the oxygen content in the water.

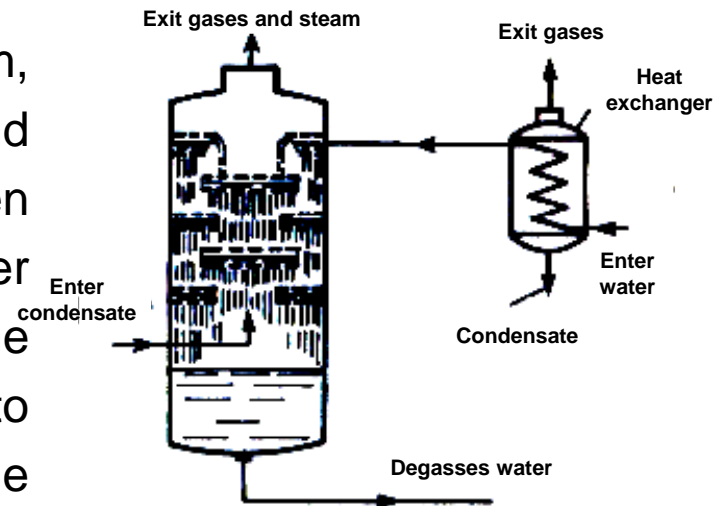

Waste treatment plants

Solid waste incineration

The operation of a "waste to energy plant" can be divided into a few basic steps:

e) *energy recovery with electricity production*

This section includes the following elements:

- group of electric food boilers (one spare) and a group diesel for emergency situations;
- groups for the reduction of the pressure and for the superheating of steam;
- dose groups (tank, agitator, dosing pumps) for the chemical treatment of boiler water;
- demineralized water production plant for the reinstatement of the boiler water;

Waste treatment plants

Solid waste incineration

The operation of a "waste to energy plant" can be divided into a few basic steps:

e) *energy recovery with electricity production*

This section includes the following elements:

- group of towers of evaporation for the production of cold water necessary for the condensation of the steam and the heat cycle, and then to chill the auxiliary devices of the turbine generator.

In the towers the flow of cooling air is provided by means of suitable fans (Figure). The towers are installed above a suitable collection tank cooling water, made of masonry. To avoid the drawbacks typical of condensation water which fouling, corrosion, deposits and microbiological growth, it is suitably treated by the addition of certain quantities of dispersant, of antiscalant and algaecide

Waste treatment plants

Solid waste incineration

The operation of a "waste to energy plant" can be divided into a few basic steps:

e) energy recovery with electricity production

This section includes the following elements:

- group of towers of evaporation for the production of cold water

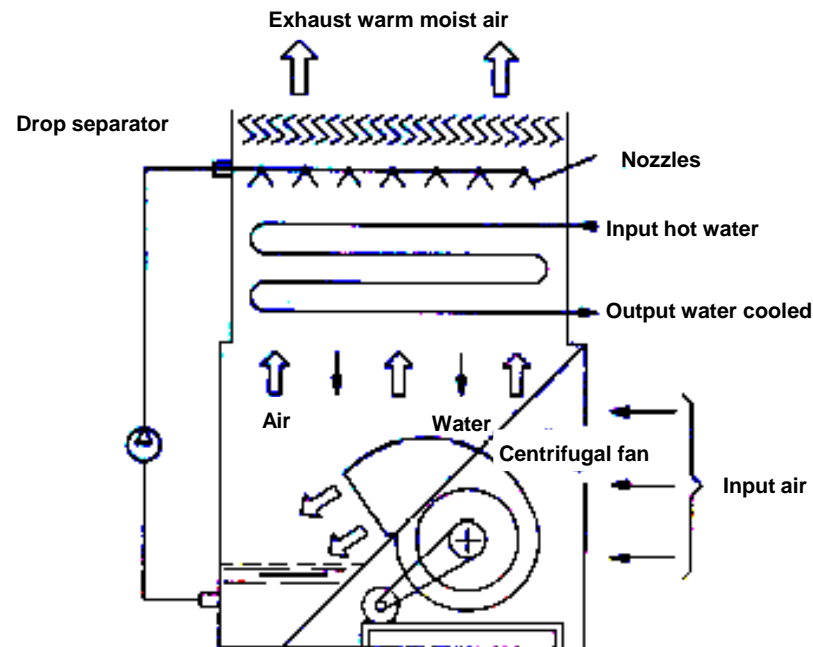

Waste treatment plants

Solid waste incineration

The operation of a "waste to energy plant" can be divided into a few basic steps:

e) energy recovery with electricity production

This section includes the following elements:

- water circulation pumps of the tower;
- emergency pump driven by the generator;
- dose groups for the treatment of water tower;
- district heating network to convey the heat transfer fluid to users;
- groups of pumps for conveying the fluid.

Waste treatment plants

Solid waste incineration

The operation of a "waste to energy plant" can be divided into a few basic steps:

f) *treatment of smokes*

The operation of smokes treatment consists of several steps:

- smoke cooling;
- treatment of acid gases;
- insertion of the activated carbon;
- dedusting;
- Scrubber finisher;
- post-heating;
- suction and expulsion of the fireplace.

Waste treatment plants

Solid waste incineration

The operation of a "waste to energy plant" can be divided into a few basic steps:

f) *treatment of smokes*

It is provided in the post-combustion chamber the injection of urea for the reduction of the oxides of nitrogen.



Waste treatment plants

Solid waste incineration

The operation of a "waste to energy plant" can be divided into a few basic steps:

f) *treatment of smokes*

The fumes leaving the boiler at 180-200°C are treated with a reduction of acid compounds in a reactor where absorption is sprayed a solution of milk and lime.

Is inserted in the connection between the output of the boiler and the sleeve filter a dry reactor in which the reagent add sodium bicarbonate. The same point is also injects activated carbon transported by means of ejector flow transport of bicarbonate.

Waste treatment plants

Solid waste incineration

The operation of a "waste to energy plant" can be divided into a few basic steps:

f) treatment of smokes

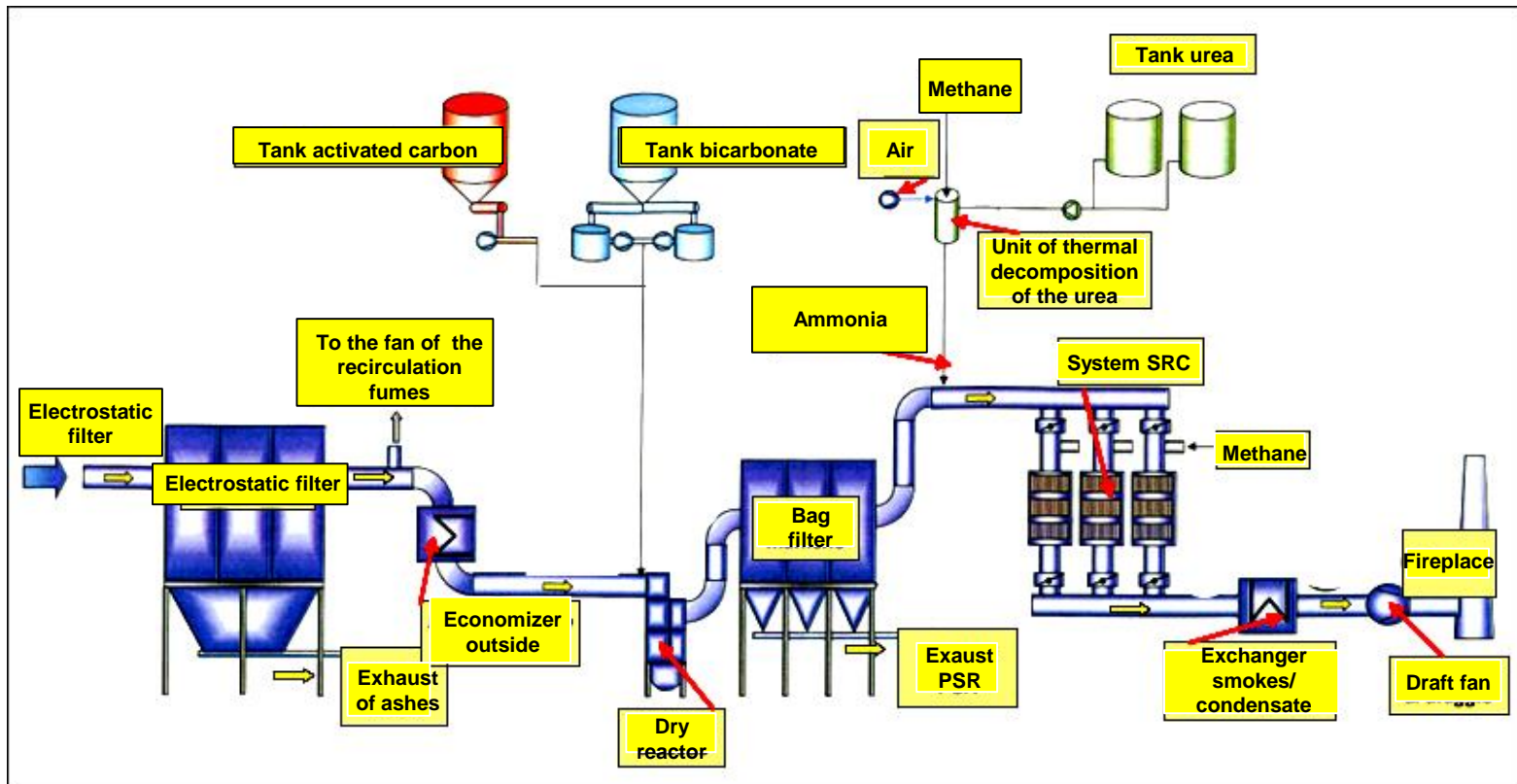

Waste treatment plants

Solid waste incineration

The operation of a "waste to energy plant" can be divided into a few basic steps:

f) *treatment of smokes*

Through a pneumatic transport it has the injection of activated carbon, followed by a treatment with dedusting with sleeves filter.

It uses the principle of fluo-liquid suspension in order to increase the contact surface between pollutants, powders and reagents. The same volume is dimensioned so as to allow the proper contact time equal to three seconds. The chemical-physical process of absorption is influenced by the proportion of reactive gas present, the contact time and the speed of passage.

Waste treatment plants

Solid waste incineration

The operation of a "waste to energy plant" can be divided into a few basic steps:

f) *treatment of smokes*

The structure of the reactor is composed of:

- a Venturi throat to increase the turbulence and promote good mixing flue-reagents;
- lances for the injection of reagents;
- a vertical cylindrical body able to ensure an appropriate contact time, consists of a concentric double chamber (an ascending and a descending).

Waste treatment plants

Solid waste incineration

The operation of a "waste to energy plant" can be divided into a few basic steps:

f) *treatment of smokes*

The estimated consumption of sodium bicarbonate is equal to 115 kg/h, while that of the active carbon is equal to 3 kg/h.

The subsequent treatment of deacidification is carried out with a washing finishing with soda in the column to the perforated plates to one stage. The powders are transported to the storage site, while the purging of the washing column.

Waste treatment plants

Solid waste incineration

The operation of a "waste to energy plant" can be divided into a few basic steps:

f) *treatment of smokes*

It is expected an intervention on the final part of the fume line aimed at the lowest energy exploitation of the plant as a whole: the replacement of the heat exchanger fed with a heat exchanger smokes-smokes. This allows a considerable saving of steam, and hence a greater production of electricity. Conceptually, the installation of a heat exchanger smokes-smokes is very simple, because it exploits the heat content of exhaust smokes from the sleeve filter for post-heat the cold smokes coming out from the washing tower.

Waste treatment plants

Solid waste incineration

The operation of a "waste to energy plant" can be divided into a few basic steps:

f) *treatment of smokes*

The sleeves filter must be characterized by high efficiency to reduce the concentration of dust within the terms of the law, the threshold of about 10 mg/Nm³.

It consists of multiple modules operating in parallel that can be individually excluded, thanks to the cells isolated from each other and equipped with valves; the modularity of the filter allows the continuity of service is in the process of preventive maintenance (cleaning individual sleeves by means of pulses of compressed air), that in the process of corrective maintenance. In addition to facilitating access of specialized personnel, parts of the filter are all accessible from the roof.

Waste treatment plants

Solid waste incineration

The operation of a "waste to energy plant" can be divided into a few basic steps:

f) treatment of smokes

The rate of filtration is adopted such as to contain the pressure losses, to reduce the frequency of cleaning and the resultant consumption of compressed air and such as to maintain as long as possible on the sleeves layer of reagent.

Waste treatment plants

Solid waste incineration

The operation of a "waste to energy plant" can be divided into a few basic steps:

f) treatment of smokes

The collection of dust captured by the sleeves is carried out in the lower part of the structure of the filter with the aid of heated hoppers by means of electric resistors; the heating allows to counteract the compaction of the powders due to moisture and so facilitate unloading.

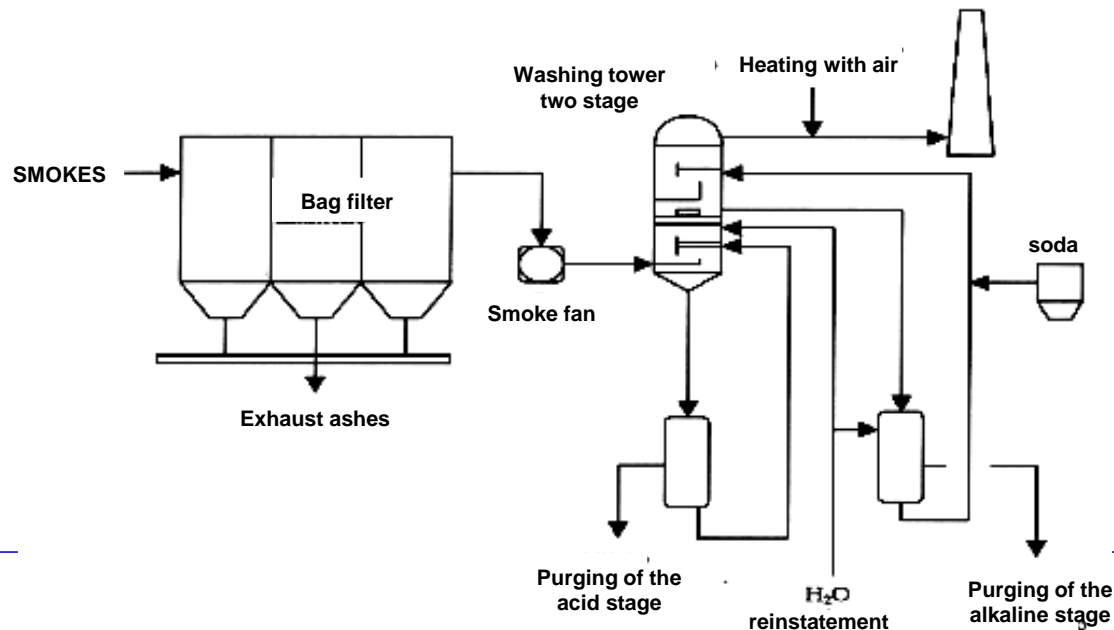

Waste treatment plants

Solid waste incineration

The operation of a "waste to energy plant" can be divided into a few basic steps:

f) *treatment of smokes*

A further cleaning treatment of the smokes is washed in a column located downstream of the abatement system of pollutants dry with sodium bicarbonate and activated carbon.

The column has the function to remove traces of acid gases and heavy metals still present in the smokes; using as reagent neutralizing an aqueous solution of caustic soda.

The washing system is a single stage, but may be in two-stage column.

Waste treatment plants

Solid waste incineration

The operation of a "waste to energy plant" can be divided into a few basic steps:

f) *treatment of smokes*

The column of appropriate diameter (2.5-3.5 m) is constituted by a ramp spray, by two plates to valves and by a droplet separator. It is equipped with a circulation system for the absorption of aqueous solution that includes a group of horizontal centrifugal pumps having a specific flow rate and head.

After washing, the fumes are heated to 120°C is to prevent the formation of the plume from the exhaust that to improve the diffusion into the atmosphere.

The exhaust pipe is secured by a draft fan place in the queue to the system, dimensioned to overcome the pressure load overall.

Waste treatment plants

Solid waste incineration

The operation of a "waste to energy plant" can be divided into a few basic steps:

f) treatment of smokes

