

Sistema di Propulsione Lanciatori

MATRICE DEI SISTEMI

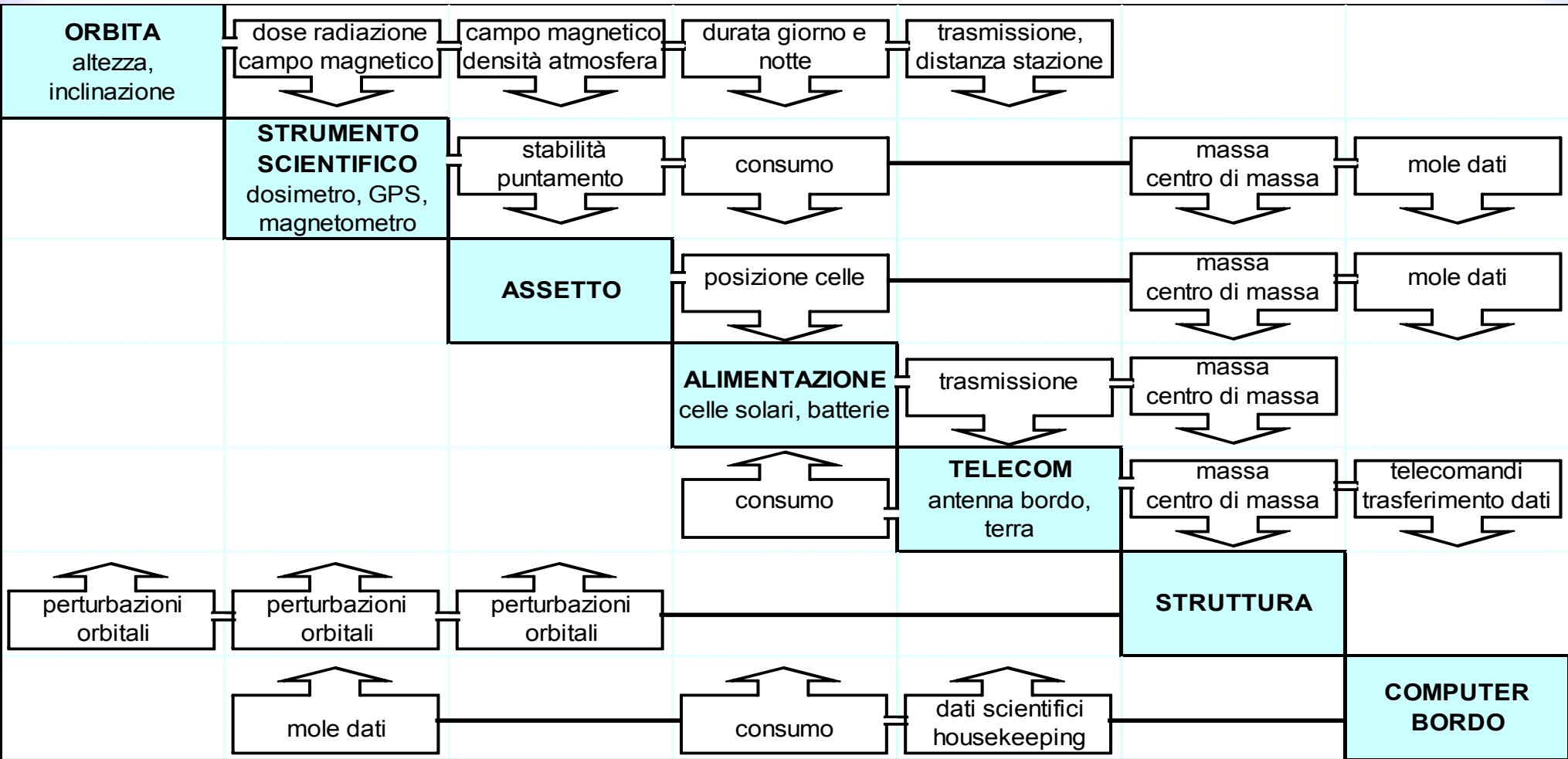

(SOTTO)-SISTEMI

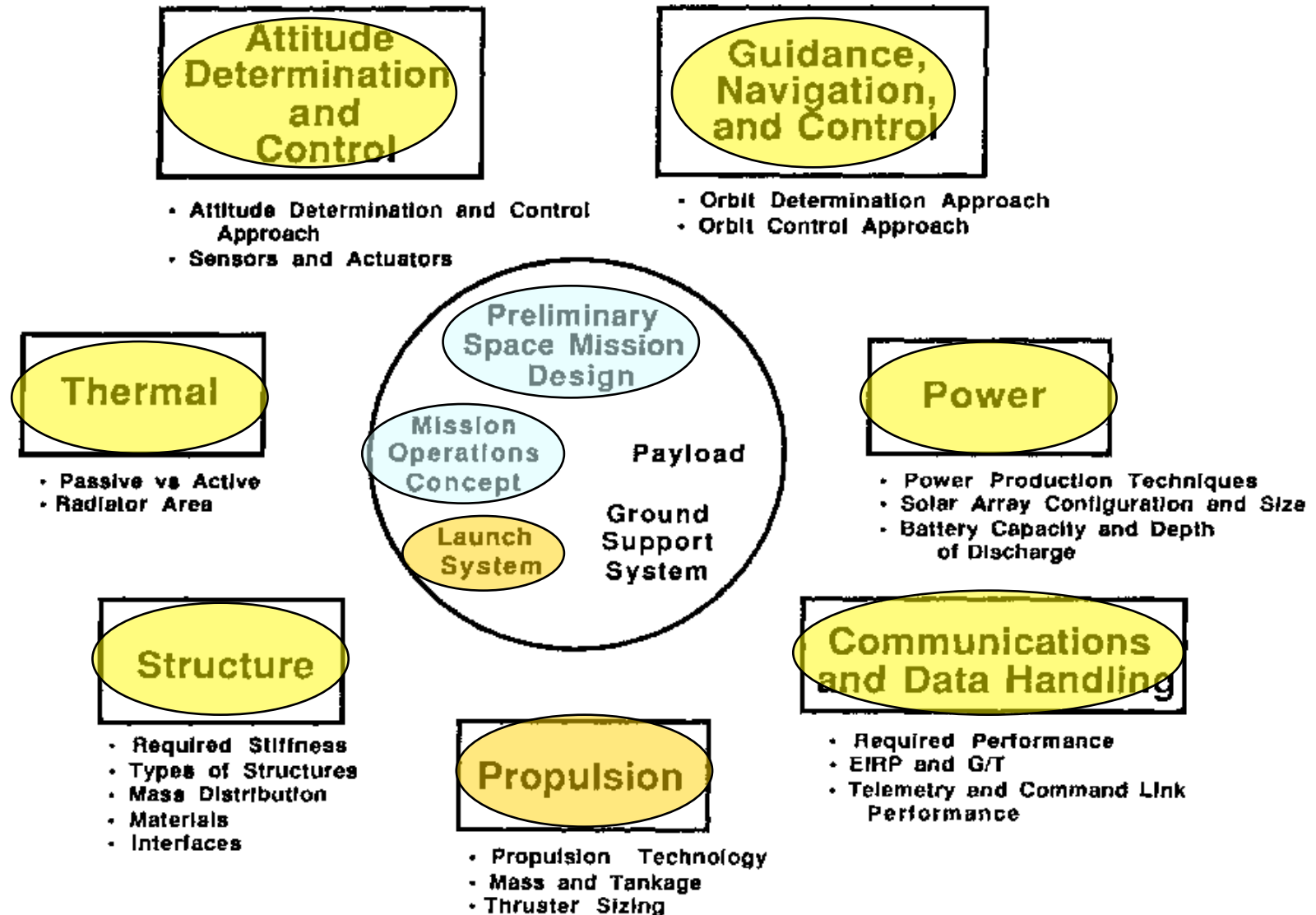

Utilizzo

- Operazioni di lancio
- Trasferimenti orbitali
- Mantenimento della missione
- Controllo di assetto

Categorie:

- Propulsione gas freddo
- Reazioni chimiche
- Accelerazione ioni / elettroni

Principio di funzionamento 1/4

Conservazione del momento

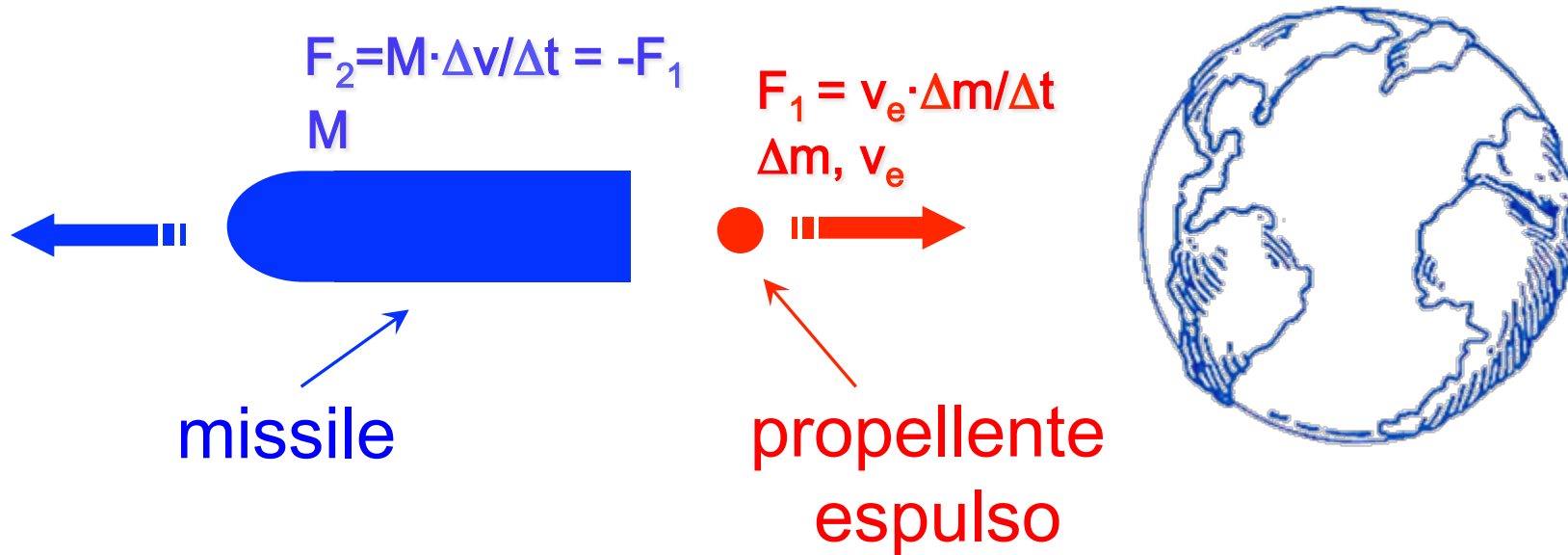

Principio di funzionamento 2/4

$$dp/dt = d(Mv)/dt = M dv/dt + v_e dM/dt = F_1 + F_2 = 0$$

velocità gas
espulso

$$F_1 = -F_2 \Rightarrow M dv/dt = -v_e dM/dt$$

massa totale a
combustibile esaurito

$$v_b = v_e \log(M/M_b)$$

equazione dei razzi

velocità razzo a
combustibile esaurito

$$F = v_e dM/dt \dots$$

spinta
(thrust)

$$F = v_e dM/dt + A_e(p_e - p_a)$$

superficie
ugello

pressione gas
in uscita

pressione
atmosferica

Principio di funzionamento 3/4

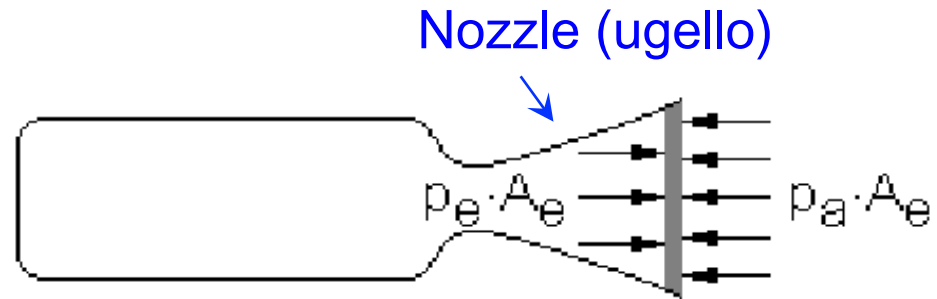

$$F = v_e \frac{dM}{dt} + A_e(p_e - p_a)$$
$$= v_{\text{eff}} \frac{dM}{dt}$$

$p_e > p_a$ under-expansion

$p_e = p_a$ ideal expansion

$p_e < p_a$ over-expansion

$$I_{\text{sp}} = F / g \frac{dM}{dt} = F / g \dot{M} \quad \text{Impulso Specifico}$$
$$= v_{\text{eff}} / g$$

$$I_{\text{sp}} = K \sqrt{T_c / \mu} \quad (\text{propulsione chimica})$$

Principio di funzionamento 4/4

$$v_{\text{eff}} = g I_{\text{sp}} = F / \dot{M} = C_f \cdot C^* \Rightarrow I_{\text{sp}} = C_f \cdot C^* / g$$

velocità caratteristica

coefficiente di spinta

$$C^* = p_c A_t / \dot{M}$$

$$C_f = F / p_c A_t$$



$$\Delta v = v_{\text{eff}} \log(M/M_b) = g I_{\text{sp}} \log(M/M_b)$$

$$M = M_b e^{\Delta v / g I_{\text{sp}}}$$

$$\Delta M = M_p = M_b (e^{\Delta v / g I_{\text{sp}}} - 1)$$

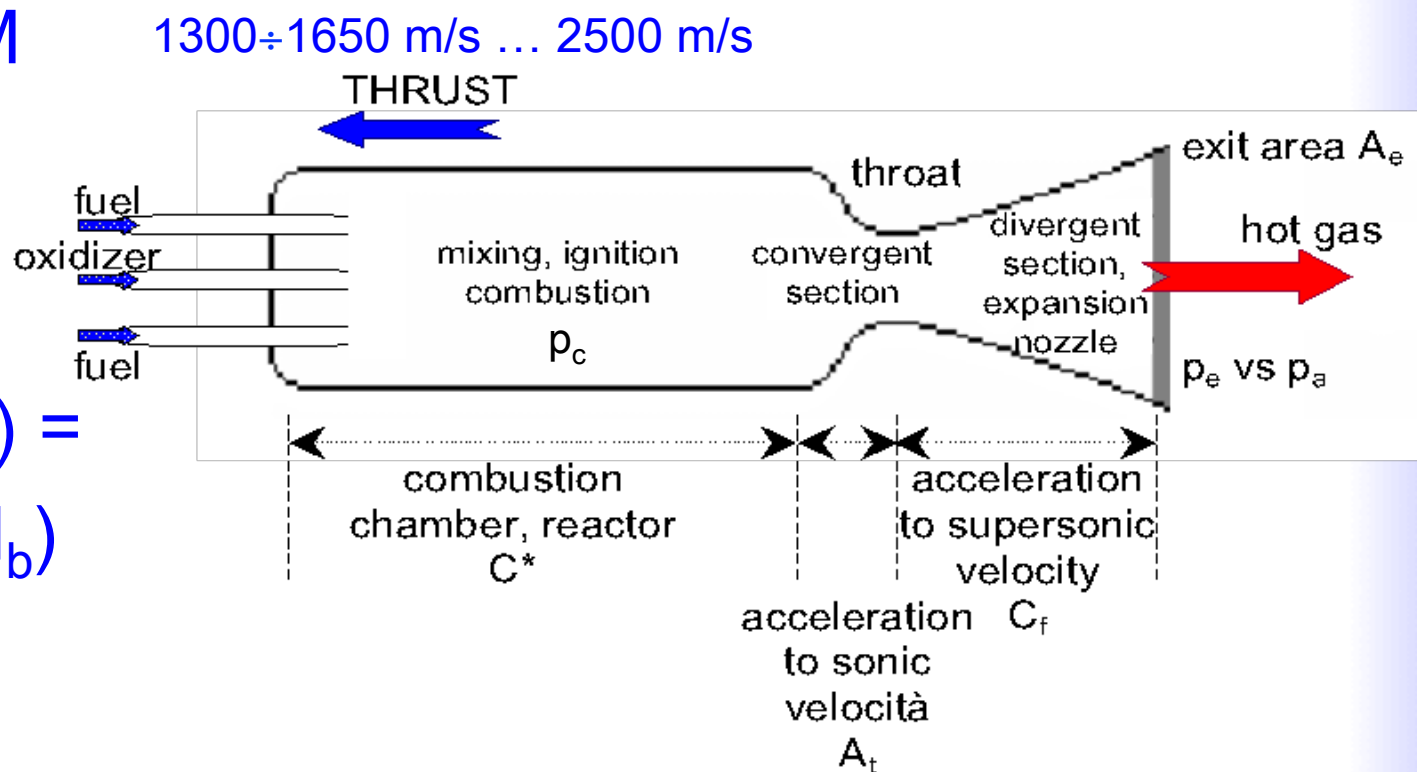

Razzi a Multistadi 1/3

$$\Delta v_i = v_{\text{eff},i} \log(M_i/M_{b,i}) = g I_{\text{sp},i} \log(M_i/M_{b,i})$$

$$v_b = \sum_i \Delta v_i = g \sum_i I_{\text{sp},i} \log(M_i/M_{b,i})$$

frazione di carico

frazione di struttura

$$\lambda_i = M_{c,i} / M_i$$

$$\varepsilon_i = M_{s,i} / M_i = (M_i - M_{c,i} - M_{p,i}) / M_i$$

$$\varepsilon_i + \lambda_i = (M_i - M_{p,i}) / M_i = M_{b,i} / M_i$$

$$\Delta v_i = g I_{\text{sp},i} \log(1/(\varepsilon_i + \lambda_i))$$

massa di struttura

$$(M_i = M_{p,i} + M_{c,i} + M_{s,i})$$

massa propellente

massa carico = $\sum_{i+1} (M_{p,j} + M_{s,j}) + m_{\text{PL}}$

Razzi a Multistadi 2/3

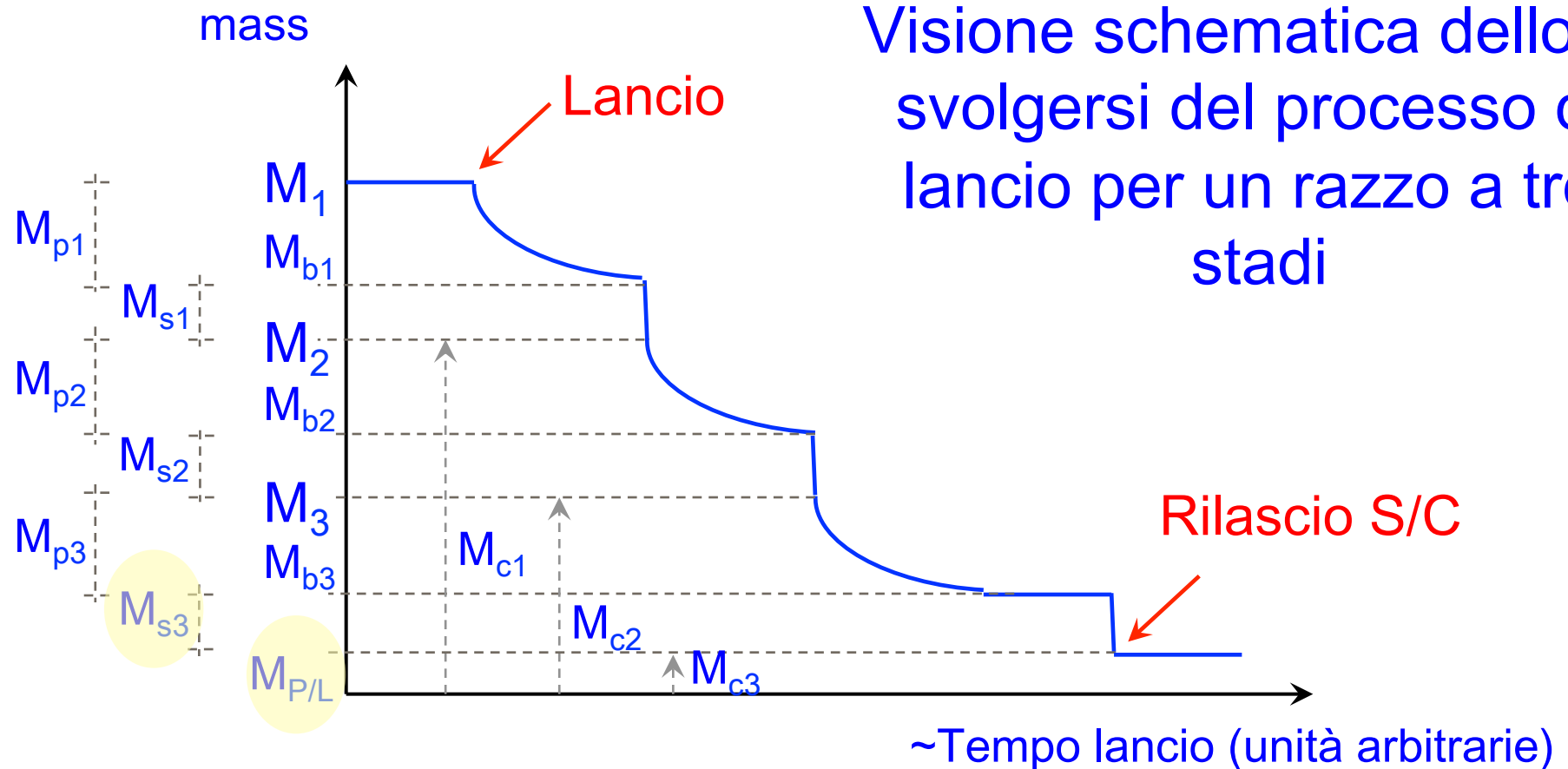

Razzi a Multistadi 3/3

Esercizio:

razzo a 3 stadi

massa iniziale 100 t

frazione di carico $\lambda_i = 0.279$ (ogni stadio)

massa propellente consumato / massa del solo stadio
(struttura+prop.): $a = 0.831$ (ogni stadio)

Calcolare masse propellenti e componenti ad ogni stadio

(trucco: calcolare
 $(1-a) \times (1-\lambda) = ?$)

stadio	m_i	$m_{s,i}$	$m_{p,i}$	$m_{c,i}$
1	100.0	12.2	59.9	27.9
2	27.9	3.4	16.7	7.8
3	7.8	0.9	4.7	2.2
P/L	2.2			

Equazione dei Razzi (cont.)

Ultimo stadio

$$M_{\text{finale}} = M_{\text{inerte}} + m_{\text{PL}} \quad \leftarrow \text{payload / dry mass (spacecraft)}$$

$$M_{\text{iniziale}} = M_p + M_{\text{finale}} = M_p + M_{\text{inerte}} + m_{\text{PL}} = M_{\text{finale}} e^{\Delta v / g_{\text{Isp}}}$$

$$M_{\text{stage}} = M_p + M_{\text{inerte}}$$

$$f_{\text{inerte}} = M_{\text{inerte}} / M_{\text{stage}}$$

$$f_{\text{prop}} = M_p / M_{\text{stage}} = 1 - f_{\text{inerte}}$$



$$M_{\text{inerte}} = M_p f_{\text{inerte}} / (1 - f_{\text{inerte}})$$

$$M_p = \frac{m_{\text{PL}} (e^{\Delta v / g_{\text{Isp}}} - 1)(1 - f_{\text{inerte}})}{1 - f_{\text{inerte}} e^{\Delta v / g_{\text{Isp}}}}$$

$$f_{\text{inerte}} = 0.08 \div 0.32 \text{ (prop. liquidi)}$$

$$= 0.06 \div 0.14 \text{ (prop. solidi)}$$

$$= 0.60 \div 0.75 \text{ (attitude control)}$$

Equazione dei Razzi (cont.)*

Hohmann Transfer 150 / 600 km.

➤ Calcolare i Δv

Supponendo che $I_{sp} = 320$ s, $m_{P/L} = 1604.25$ kg, $f_{inerte} = 17\%$ e la durata della spinta sia di 45 s:

➤ Calcolare la massa del propellente necessaria (con margini 22%)

➤ La spinta totale e l'accelerazione corrispondente

System	Mass (kg)
Payload	550
Structure	300
Thermal	33
Power	386
TeleCom	54
ADCS	72
Tot	1395
Margin (15%)	209.25
S/C Dry mass	1604.25

Rifare lo stesso esercizio con un trasferimento di piano da inclinazione di 60° a 28°

Risultati

f inerte	0.17	Dt	45 s				
lsp	320 s						
Dv	256.079041 m/s	256.079041	482.1 m/s	trasferimento totale			
g	9.807 m/s ²	129.106539	126.972502 m/s	singoli trasferimenti			
Dv/glsp	0.08159957						
	1.08502125						
Mp	138.8 kg	Mp'	3.08472494 kg/s				
+margin	169.4		3.76336442 kg/s				
Minerte	28.4	33.7	Spinta	9680.60718 N			9680.60718
+margin	34.7	41.1	+margin	11810.3408 N			
+margin	39.9		Mtot	2019.92431	1808.3		
Mstage	167.2	205.5		1850.6			
+margin	204.0		accelerazione	6.53122836 m/s ²			
MTOT	1771.5	1809.7					
+margin	1808.3				1740.32834	1673.52483	
					totale	1	2 tot
Dv/glsp		Mp	138.8	67.9594871	66.8035148	134.763002	kg
totale	0.08159957	Mp'	1.54236247	1.51021082	1.48452255	2.99473338	kg/s
	1.08502125						
1	0.04113979	67.9594871	Spinta	4840.30359	4739.40402	4658.78805	9398.19207 N
	1.04199776	82.9105742	acc max		2.72100516	2.78139794	2.78139794 m/s ²
2	0.04045978	66.8035148					
	1.04128943	81.5002881					
TOT		164.410862					

Effetti gravita' e attrito atmosferico

➤ Gravita' terrestre

- Lancio verticale: $\Delta v_g = gt$
- $t \sim 100 \text{ s} \Rightarrow \Delta v \sim 1 \text{ km/s}$

➤ Attrito atmosferico

- $F \sim \frac{1}{2} \rho A v^2 C_D$
- $\Delta v_a \sim \frac{1}{3} \Delta v_g$

Struttura

- Struttura leggera ma resistente: acciaio, leghe Al, titanio
- Resistenza vs peso: serbatoi sferici (cilindrici)
- Attrito atmosferico: sezione razzo piccola
- Attrito atmosferico: forma aerodinamica a cono

Classificazione

- Gas freddo
- Reazioni chimiche
 - Propellente liquido
 - Propellente solido
 - Propellente ibrido
- Accelerazione ioni/elettroni/plasma
- Reazioni nucleari
- Vele solari
-

Budget di velocità

Determina la scelta del sistema di propulsione !

$$\Delta v = \Delta v_g + \Delta v_{\text{drag}} + \Delta v_{\text{orbit}} + \Delta v_{\text{attitude}}$$

Mission	Description	Typical Δv [km/s]
LEO, GEO, Planetary Targets	Satellites, Robotic missions	10-15
Human Planetary Exploration	Fast, direct trajectory	30 – 200
100 – 1,000 AU (Distance Sun-Earth)	Interstellar precursor mission	100
10,000 AU	Mission to Oorth cloud	1,000
Slow Interstellar	4.5 light-years in 40 years	30,000
Fast Interstellar	4.5 light-years in 10 years	120,000

Sistemi di Propulsione 1/2

Propulsion System		Specific Impulse [s]	Maximum Δv [km/s] *	Maximum Thrust [N]
Chemical	Solid	250 – 310	5.7 – 7.1	10^7
	Liquid	300 – 500	6.9 – 11.5	10^7
MHD		< 200	4.6	10^5
Nuclear	Fission	500 – 800	11.5 – 20.7	10^6
	Fusion	10,000 – 100,000	230 – 2,300	10^5
	Antimatter	60,000	1,381	10^2
Electric	Electrothermal	150 – 1,200	3.5 – 27.6	10^1
	Electrostatic	1,200 – 10,000	27.6 - 230	3×10^{-1}
	Electromagnetic	700 – 5,000	16.1 – 115	10^2
Propellantless	Photon Rocket	3×10^7	unlimited	10^{-4}
Breakthrough		?	?	?

* Assuming $(m/m_0)=0.1 \Rightarrow$ Spacecraft consists of 90% Propellant

Sistemi di Propulsione 2/2

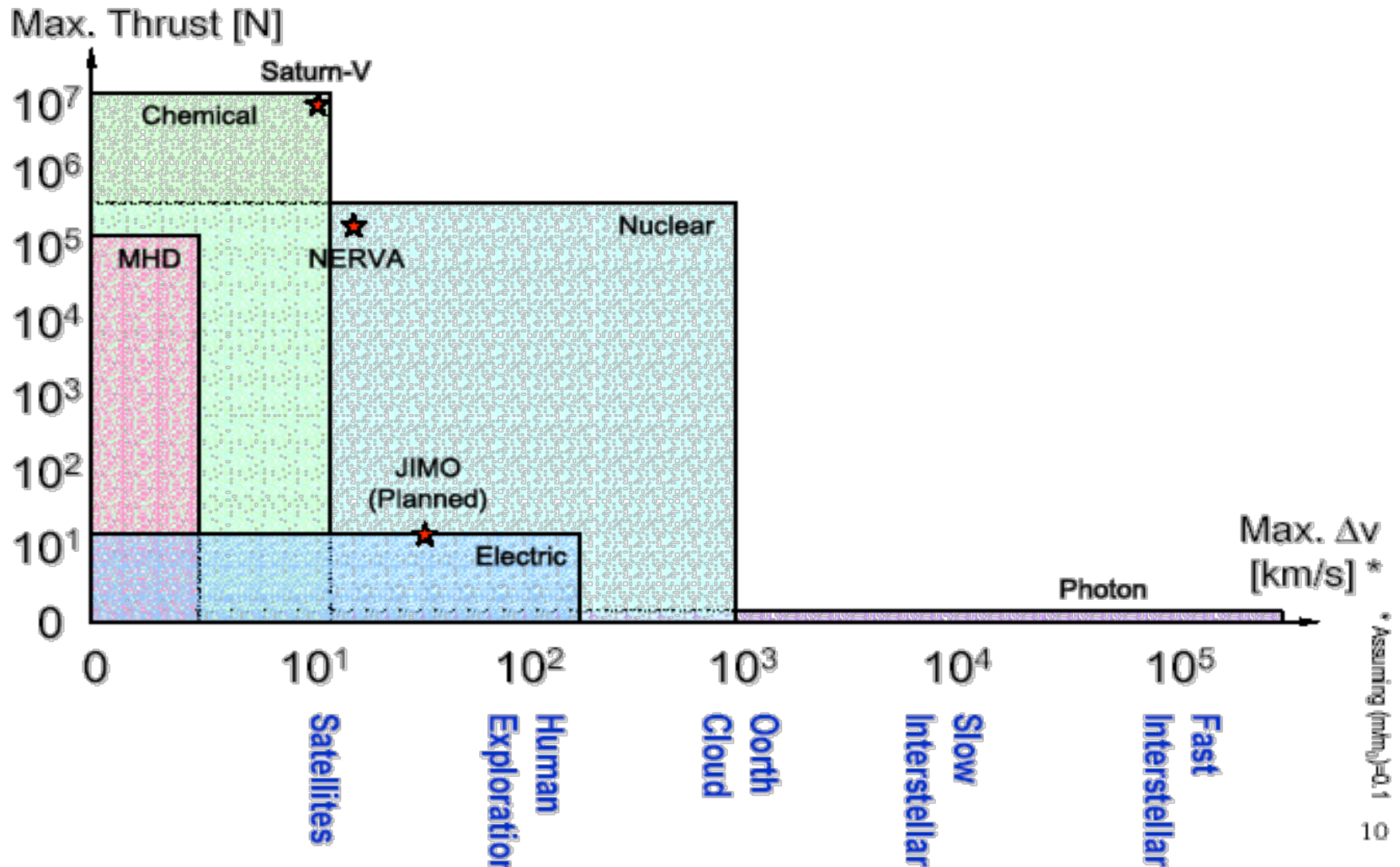

Propellente Liquido

Monopropellente

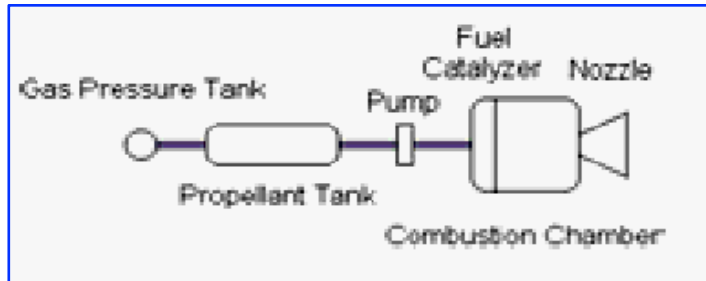

Bipropellente

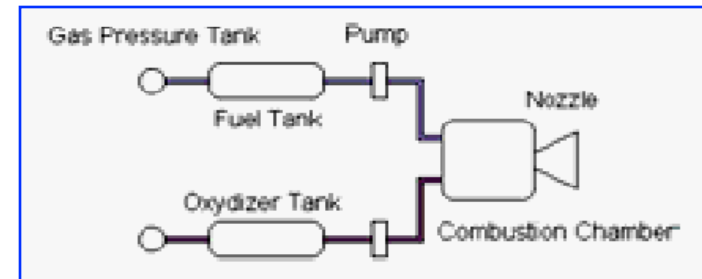

Idrazina (N_2H_4): 220-230 s

H_2O_2 : 180 s

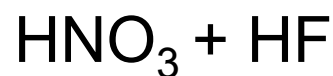

Fuel	Oxydizer	Average Density [g/cm ³]	Specific Impulse [s]
Kerosine (RP-1)	Oxygen (O ₂)	1.02	300 – 360
Hydrogen (H ₂)	Oxygen (O ₂)	0.35	415 – 470
Unsymmetrical Dimethyl Hydrazin (UDMH)	Nitrogen Tetroxide (N ₂ O ₄)	1.20	300 – 340
Hydrogen (H ₂)	Fluorine (F ₂)	0.42	450 - 480

Schema di un sistema

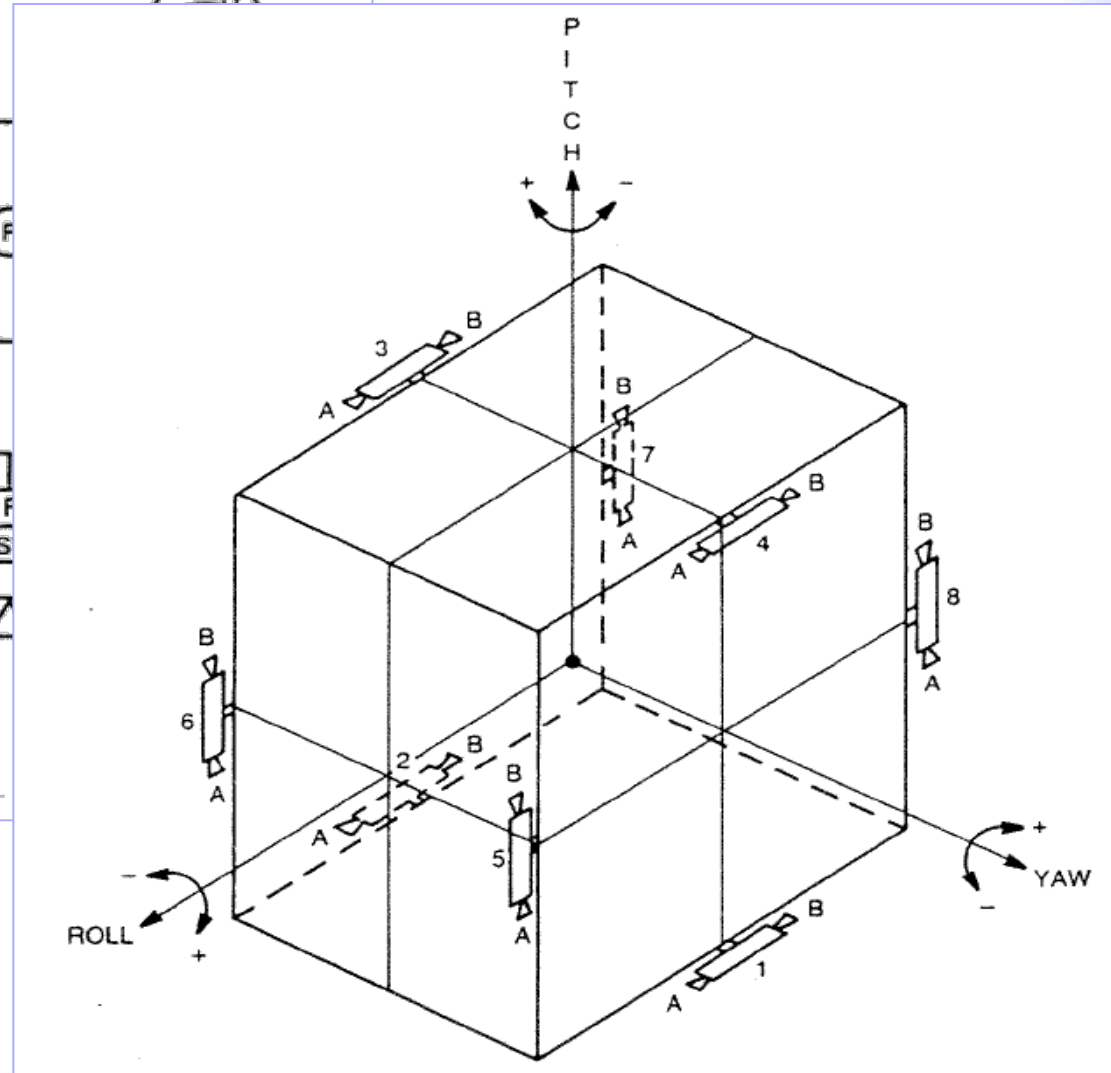
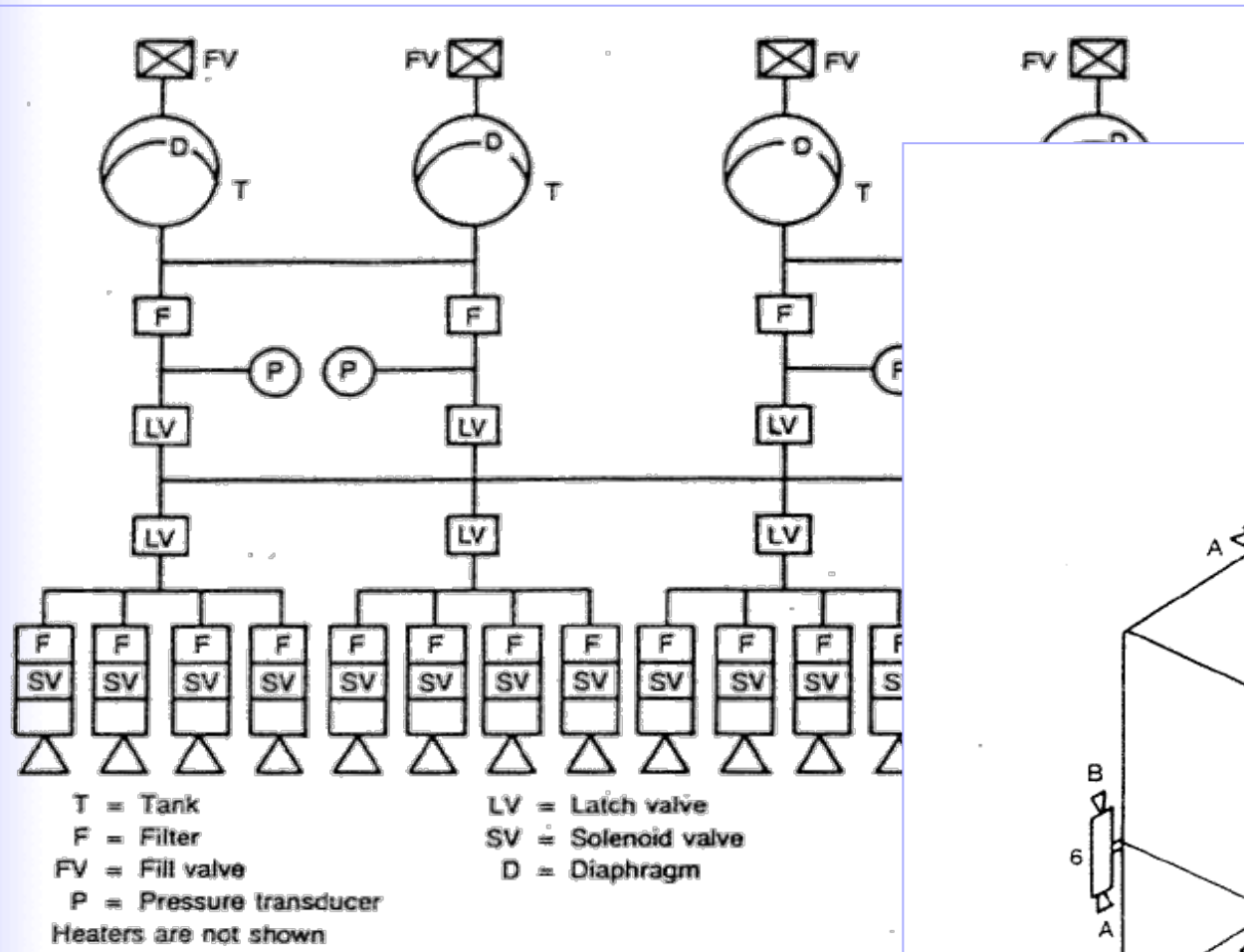

Sistemi Solidi e Ibridi

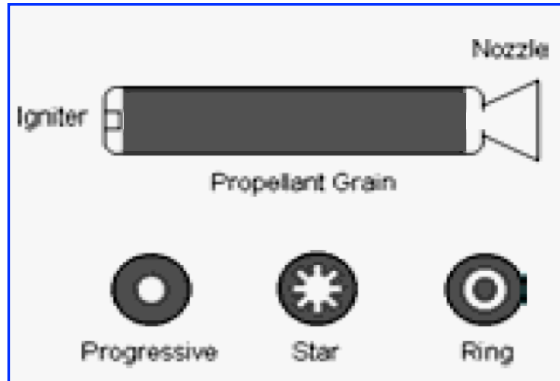

Sistema ibrido

Sistema solido

- Combustibile:
 - alluminio polverizzato
- Ossidante:
 - perclorato di ammonio (NH_4ClO_4)

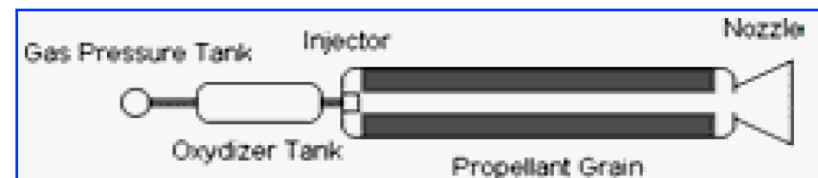

Accelerazione Ioni/Plasma

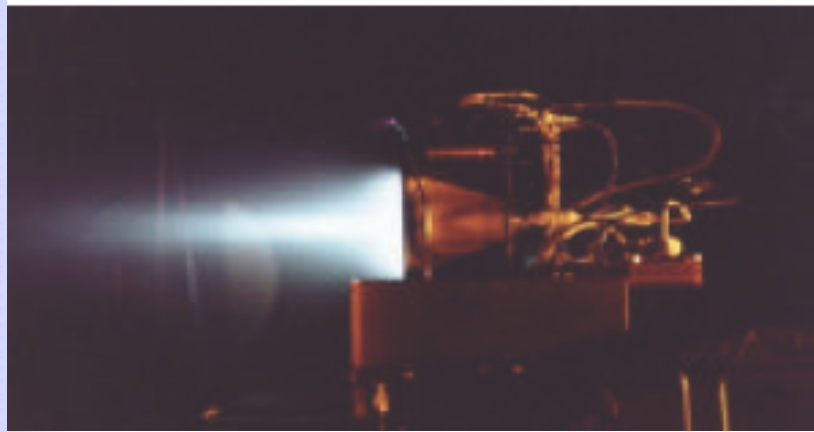

Plasma: quarto stato della materia formato da ioni e elettroni

Gli elettroni non sono legati agli ioni \Rightarrow

Plasma conduce correnti elettriche \Rightarrow

Permette accelerazione diretta del propellente *plasma* tramite **campi elettromagnetici**

- Generazione di ioni/plasma
- Accelerazione del plasma
- Neutralizzazione del fascio

$$I_{sp} = K \sqrt{V_i/m} \quad (\text{max } 4500 \text{ s})$$

$$I_{sp} \text{ max } \sim 25000 \text{ s}$$

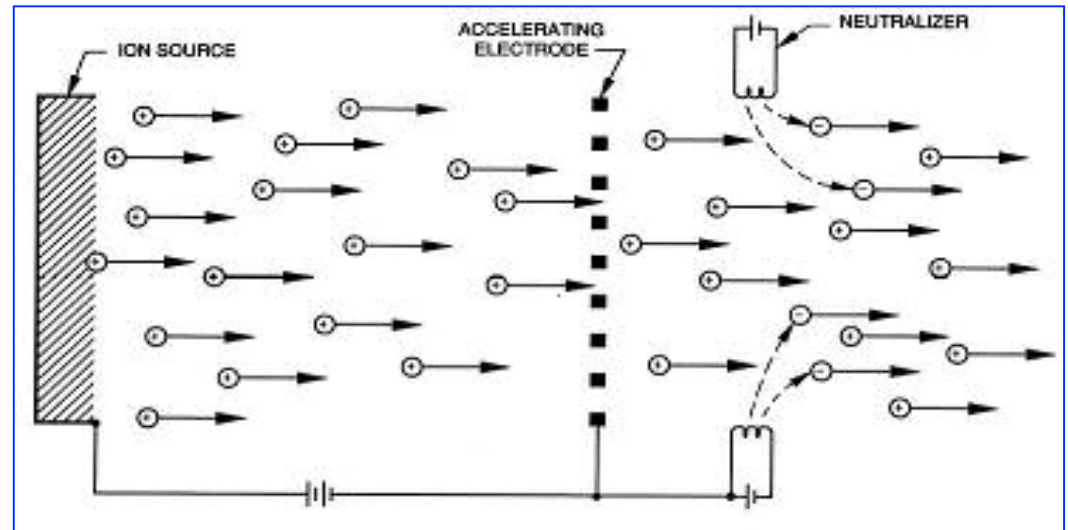

Accelerazione Ioni/Plasma

Plasma: quarto stato della materia formato da ioni e elettroni

Gli elettroni non sono legati agli ioni \Rightarrow

Plasma conduce correnti elettriche \Rightarrow

Permette accelerazione diretta del propellente *plasma* tramite **campi elettromagnetici**

- Generazione di ioni/plasma
- Accelerazione del plasma
- Neutralizzazione del fascio

$$I_{sp} = K \sqrt{V_i/m} \quad (\text{max } 4500 \text{ s})$$
$$I_{sp} \text{ max } \sim 25000 \text{ s}$$

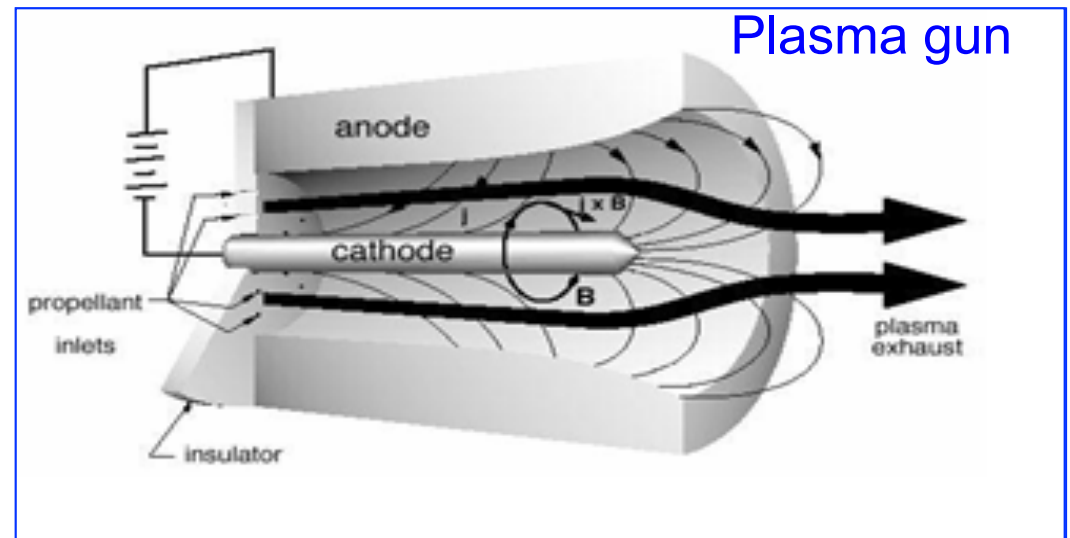

Smart 1



- Lancio: agosto 2003
- Orbita: GTO to L1
- Ellissi polare attorno alla Luna

Motore a ioni alimentato
da pannelli solari



Sistemi Nucleari

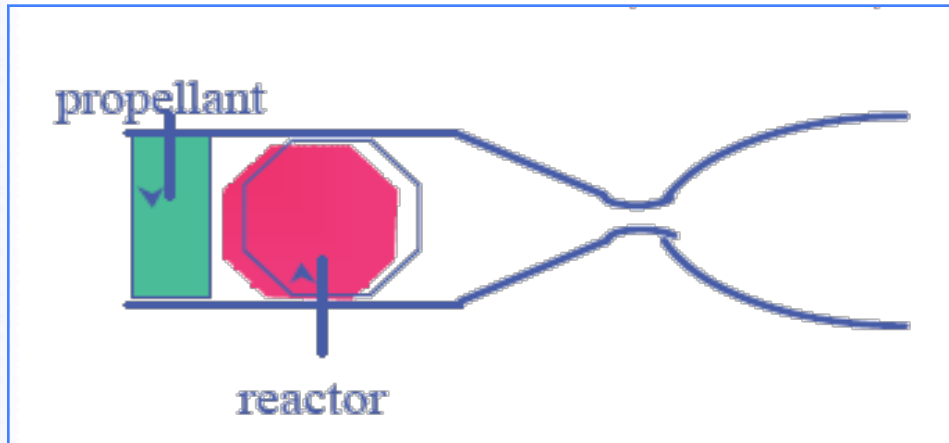

Il reattore aggiunge energia (calore) al propellente

Il propellente viene scaricato attraverso l'ugello (nozzle)

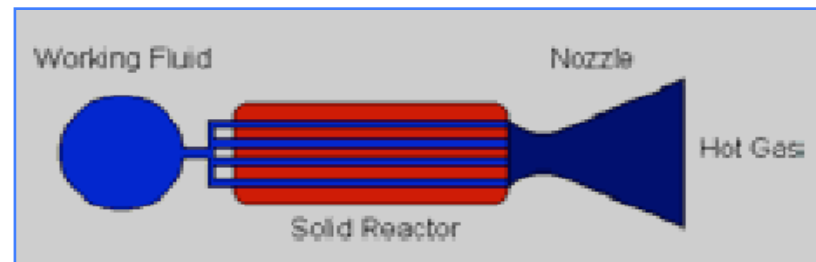
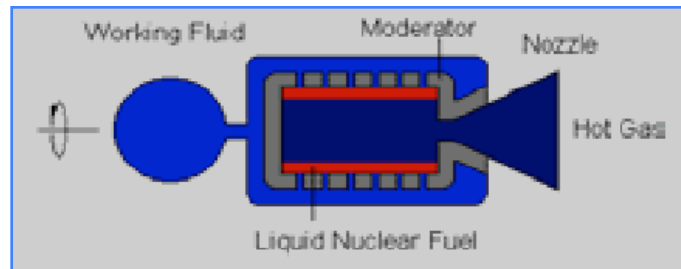

VeLe Solari 1/4

➤ Pressione di radiazione solare:

$$\circ P_{\odot} = W_{\odot} / c = L_{\odot} / (4\pi r^2 c) = K/c (r_0/r)^2$$

($K = 1368 \text{ W/m}^2$, $r_0 = 1 \text{ AU} = 1.5 \times 10^{11} \text{ m}$, $K = L_{\odot} / 4\pi r_0^2$)

$$\circ P_{\odot} = L_{\odot} / (3\pi R_{\odot}^2 c) (1 - (1 - (R_{\odot}/r)^2)^{3/2})$$

($R_{\odot} = 6.96 \times 10^8 \text{ m}$)

Pianeti	Distanza dal Sole (semiasse maggiore dell'orbita) [U A]	Flusso Solare [W/m ²]	Pressione di radiazione solare [N/m ²]
☿ Mercurio	0.387	9134	$3.046 \cdot 10^{-5}$
♀ Venere	0.723	2617	$8.729 \cdot 10^{-6}$
♁ Terra	1	1368	$4.563 \cdot 10^{-6}$
♂ Marte	1.524	589.0	$1.965 \cdot 10^{-6}$
♃ Giove	5.203	50.53	$1.686 \cdot 10^{-7}$
♄ Saturno	9.539	15.03	$5.015 \cdot 10^{-8}$
♅ Urano	19.182	3.718	$1.240 \cdot 10^{-8}$
♆ Nettuno	30.057	1.514	$5.051 \cdot 10^{-9}$
♇ Plutone	39.75	0.8657	$2.888 \cdot 10^{-9}$

Vele Solari 2/4

➤ Vela perfetta:

- $f_{P,\odot} = 2S/m P_{\odot}(r) \cos^2\alpha \mathbf{n}$

(S = superficie vela, m = massa vela, α = angolo puntamento)

- $f_{P,\odot} = 2\eta S/m K/c (r_0/r)^2 \cos^2\alpha \mathbf{n} = A/r^2 \cos^2\alpha \mathbf{n}$

(η = efficienza di riflessione = 0.85-0.9)

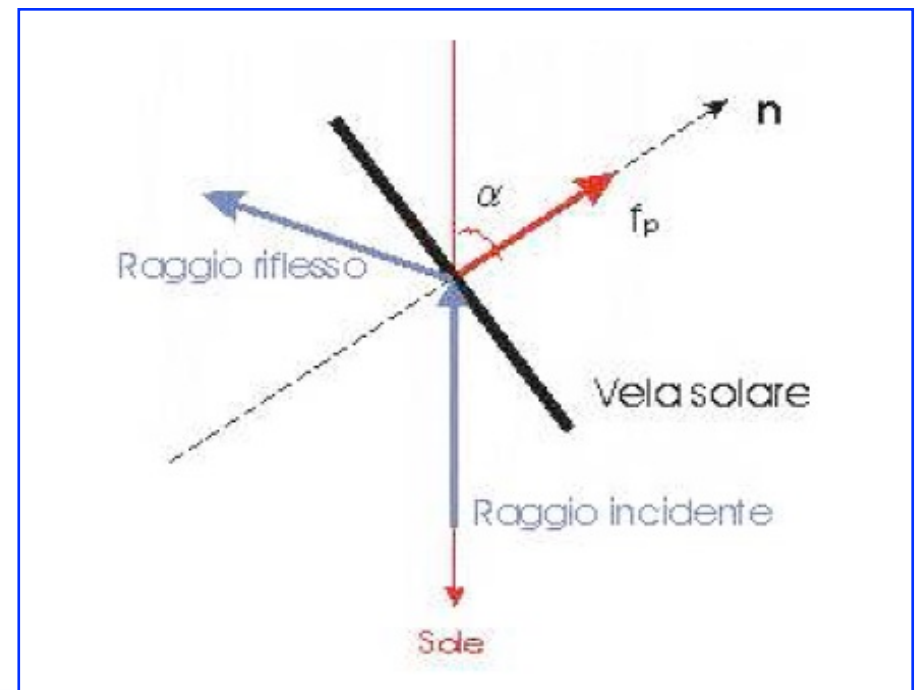

Vele Solari 3/4

➤ Modello ottico:

$$\circ f_{P,\odot} = f_i + f_{rs} + f_{ru} + f_e$$

riflessione speculare

emissione

riflessione uniforme

$$\circ f_{P,\odot} = P_{\odot}(r) S/m ((b_2 \cos^2\alpha + \rho(1-s)B_f \cos\alpha) \mathbf{n} + b_1 \sin\alpha \cos\alpha \mathbf{t}) + \dots$$

$$a + \rho = 1$$

$$b_1 = 1 - \rho s$$

$$b_2 = 1 + \rho s$$

ρ = coefficiente di riflessione

s = frazione fotoni riflessi specularmente

$$f_i: \quad \cos^2\alpha \mathbf{n} + \sin\alpha \cos\alpha \mathbf{t}$$

$$f_{rs}: \quad \rho s (\cos^2\alpha \mathbf{n} - \sin\alpha \cos\alpha \mathbf{t})$$

$$f_{ru}: \quad \rho (1-s) B_f \cos\alpha \mathbf{n}$$

$$f_e: \quad T^4 \mathbf{n}..$$

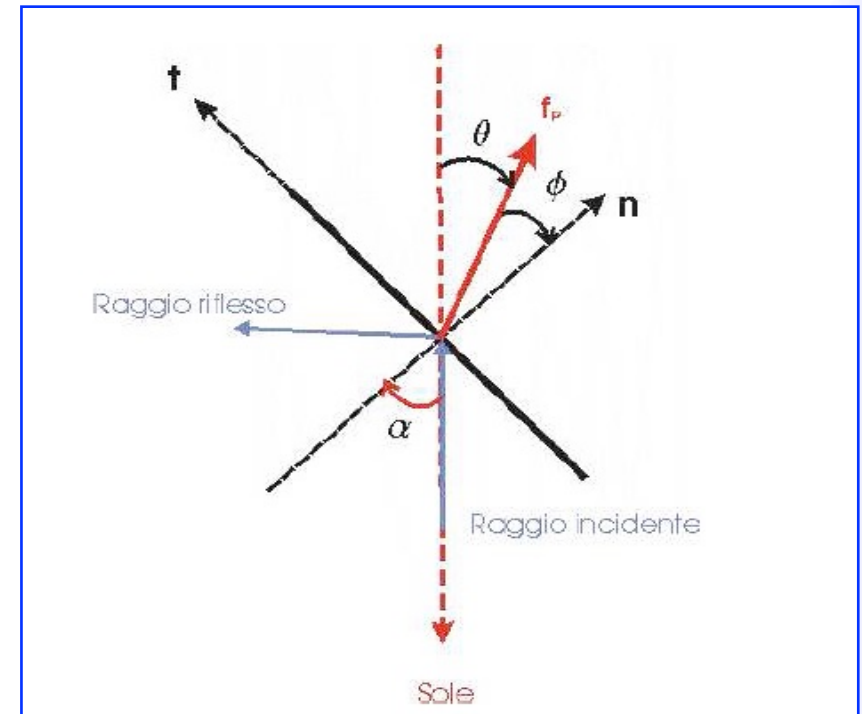

Veile Solari 4/4

