

Cyber-Physical Systems

Laura Nenzi

Università degli Studi di Trieste
II Semestre 2019

Lecture 6: Sensor and Actuators

What is a sensor? An actuator?

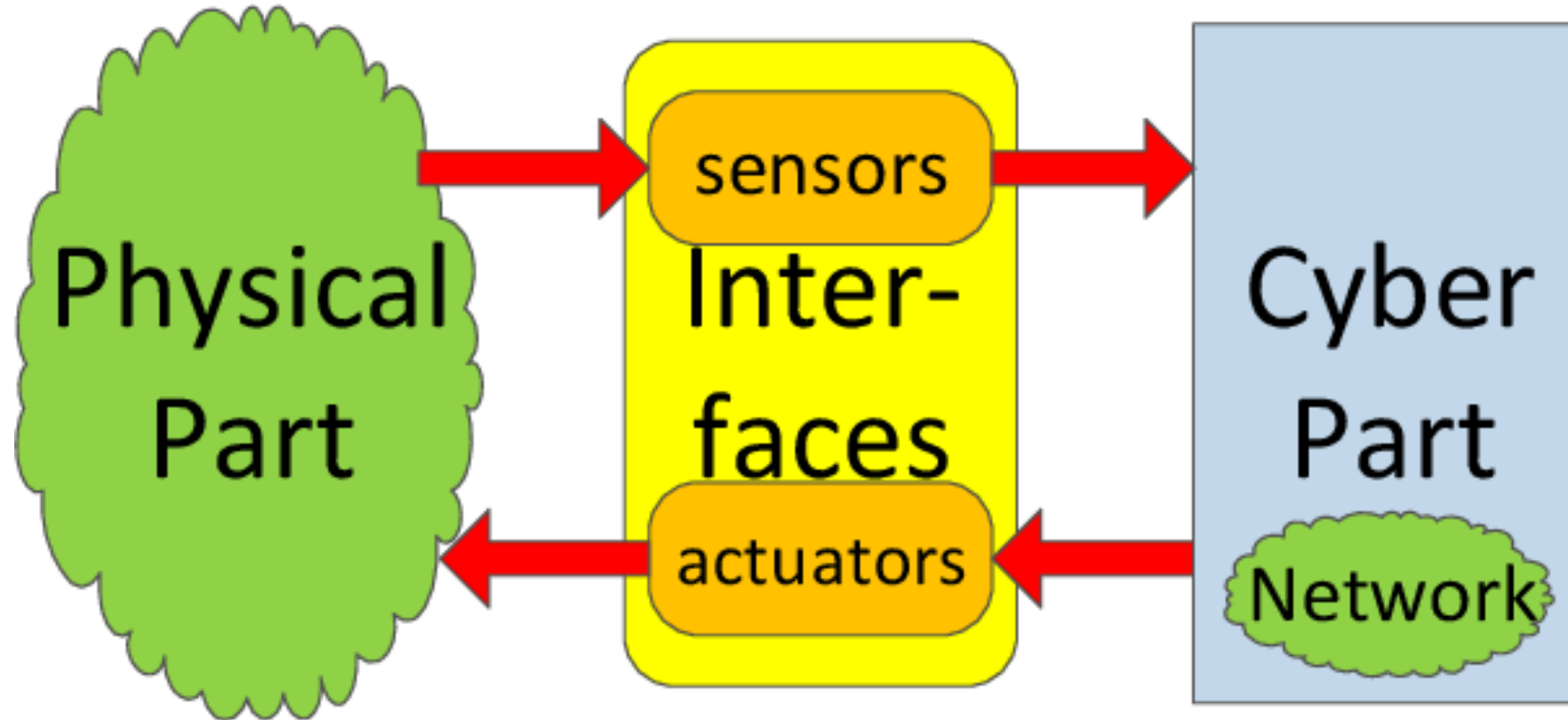

Sensor: a device that **measures** a physical quantity

Actuator: a device that **modifies** a physical quantity

Examples

Sensors:

- Cameras
- Accelerometers
- Microphones
- Magnetometers
- Radar/Lidar
- Chemical sensors
- Pressure sensors
- ...

Modeling Issues:

- Physical dynamics
- Noise
- Bias
- Sampling
- Interactions
- Faults
- ...

Actuators:

- Motor controllers
- Solenoids
- LEDs
- lasers
- LCD and plasma displays
- Loudspeakers
- Valves
- ...

ADC: Analog-to-Digital Converter

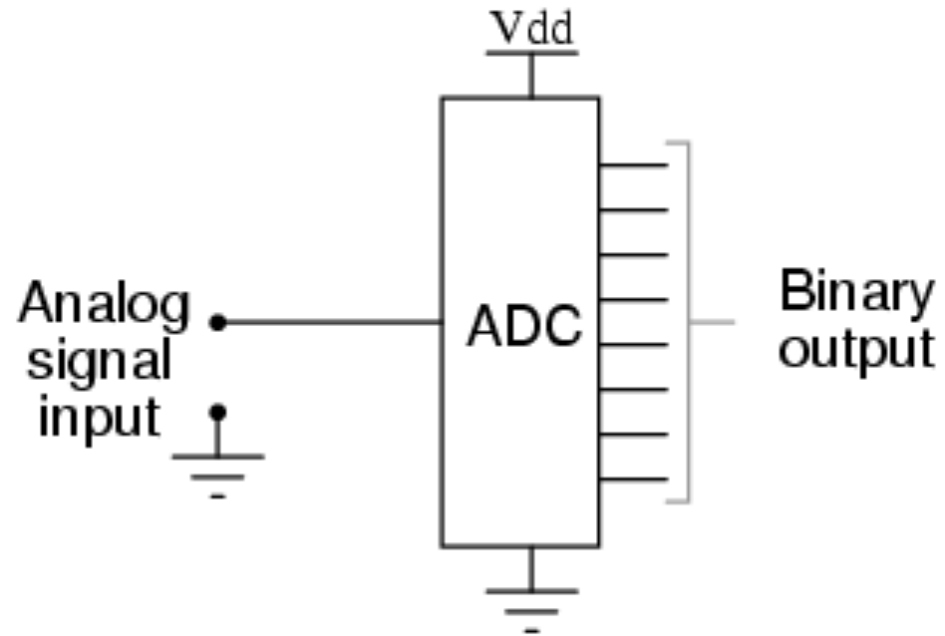

A sensor that is packaged with an ADC is called a **digital sensor**, whereas a sensor without an ADC is called an **analog sensor**

A digital sensor will have a limited precision, determined by the number of bits used to represent the number (this can be as few as one!)

DAC: Digital-to-Analog Converter

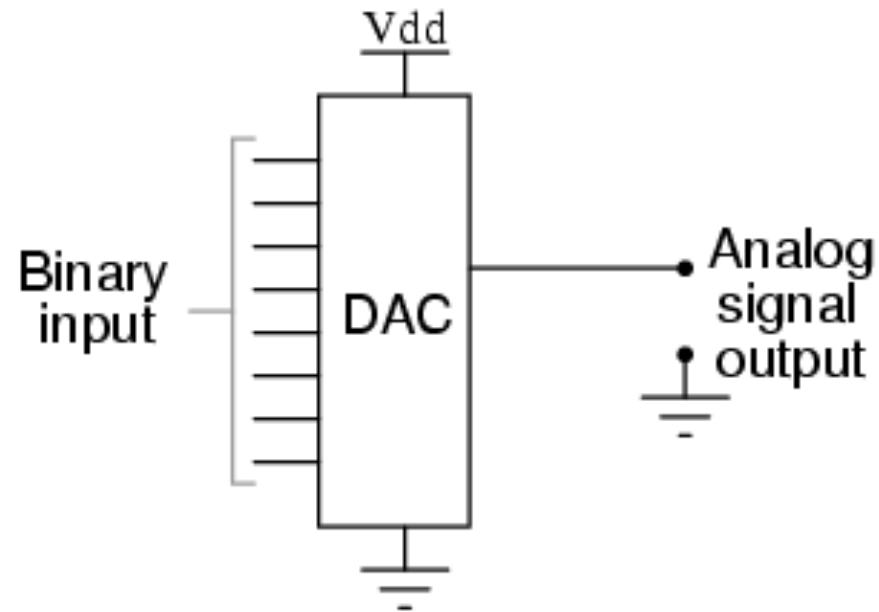

An actuator is commonly driven by a voltage that may be converted from a number by a DAC. An actuator that is packaged with a DAC is called a **digital actuator**.

Sensor-Rich Car

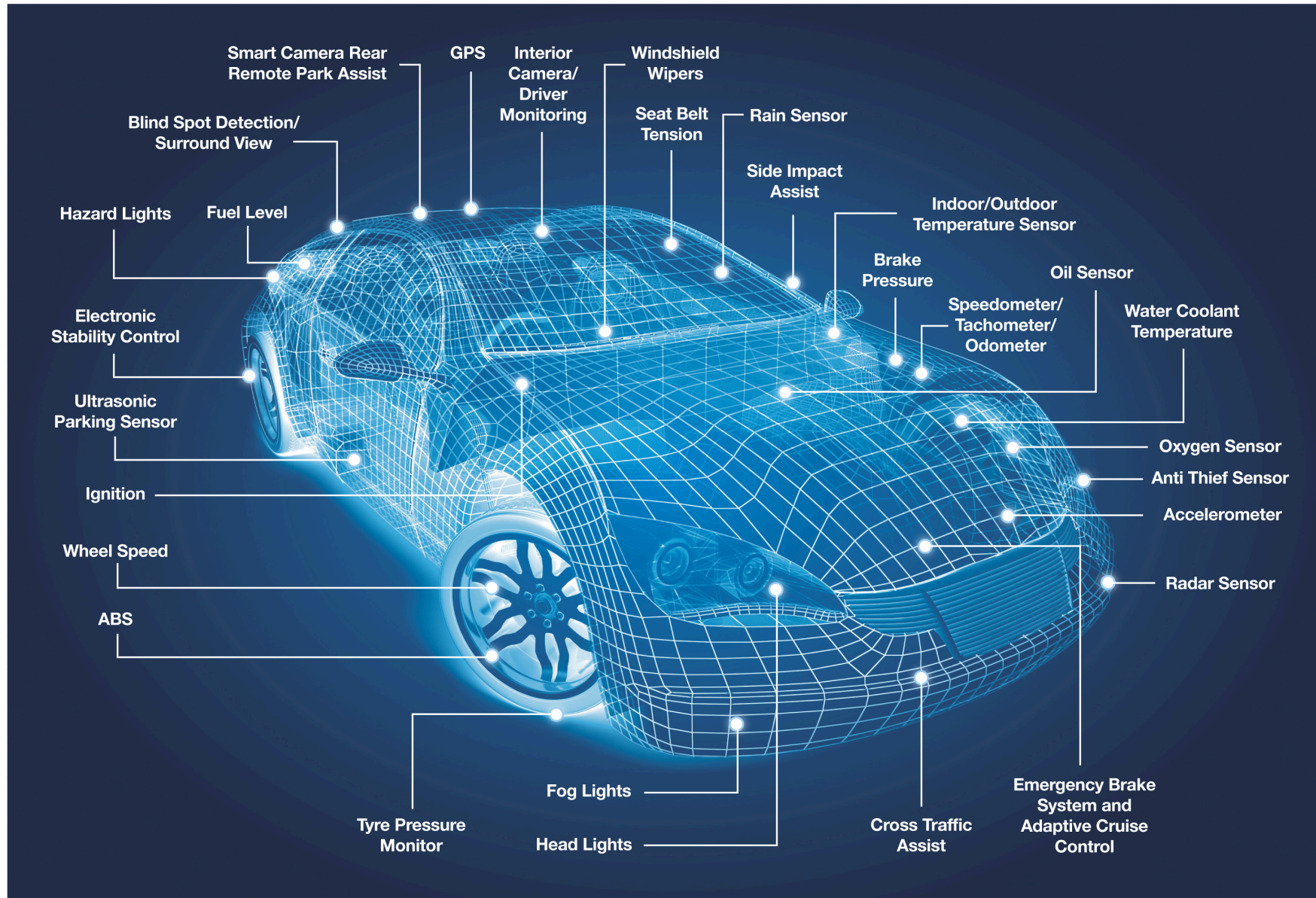

Design Issues with Sensors

- **Calibration:**
 - Relating measurements to the physical phenomenon
 - Can dramatically increase manufacturing costs
- **Nonlinearity:**
 - Measurements may not be proportional to physical phenomenon
 - Correction may be required
- **Noise:**
 - Analog signal conditioning
 - Digital filtering
- **Sampling:** how often the sensor produces output
 - Aliasing
 - Missed events

Linear and Affine Models

The function f is **linear** if there exists a proportionality constant $a \in \mathbb{R}$ such that for all $x \in \mathbb{R}$:

$$f(x) = ax$$

It is an **affine function** if there exists a **proportionality constant** $a \in \mathbb{R}$ and a **bias** b such that for all $x(t) \in \mathbb{R}$:

$$f(x) = ax + b$$

The proportionality constant represents the **sensitivity** of the sensor, since it specifies the degree to which the measurement changes when the physical quantity changes.

Range

The **range** of a sensor is the set of values of a physical quantity that it can measure.

No sensor or actuator truly realizes an affine function. In particular the range is always limited.

An affine function model of a sensor may be augmented to take this into account as follows:

$$f(x) = \begin{cases} ax + b & \text{if } L \leq x \leq H \\ aH + b & \text{if } x > H \\ aL + b & \text{if } x < L \end{cases}$$

In this case the relation between the physical quantity x and a measurement is not an affine relation (it is, however, piecewise affine). This is a simple form of non-linearity that is shared by all sensors.

Dynamical Range and Quantization

The **precision** p of a sensor is the smallest absolute difference between two values of a physical quantity whose sensor readings are distinguishable.

The **dynamic range** $D \in \mathbb{R}_+$ of a digital sensor is the ratio

$$D = \frac{H - L}{p}$$

A digital sensor represents a physical quantity using an n -bit number.

There are only 2^n distinct such numbers, so such a sensor can produce only 2^n distinct measurements.

Quantization: The actual physical quantity may be represented by a real number $x \in \mathbb{R}$, but for each such x , the sensor must pick one of the 2^n numbers to represent it.

A 3-bit digital sensor

Capable of measuring a range of $[0, 1]$ volt.

3-bit sensor means $f: \mathbb{R} \rightarrow \{0, \dots, 7\}$

Precision $p = \frac{H-L}{2^n} = \frac{1}{8}$

The (decibel) dynamic range is :

$$D = 20 \log_{10} \frac{H-L}{p} \approx 18 \text{ dB}$$

The term “**decibel**” is literally one tenth of a bel, which is named after Alexander Graham Bell. This unit of measure was originally developed by telephone engineers at Bell Telephone Labs to designate the ratio of the power of two signals.

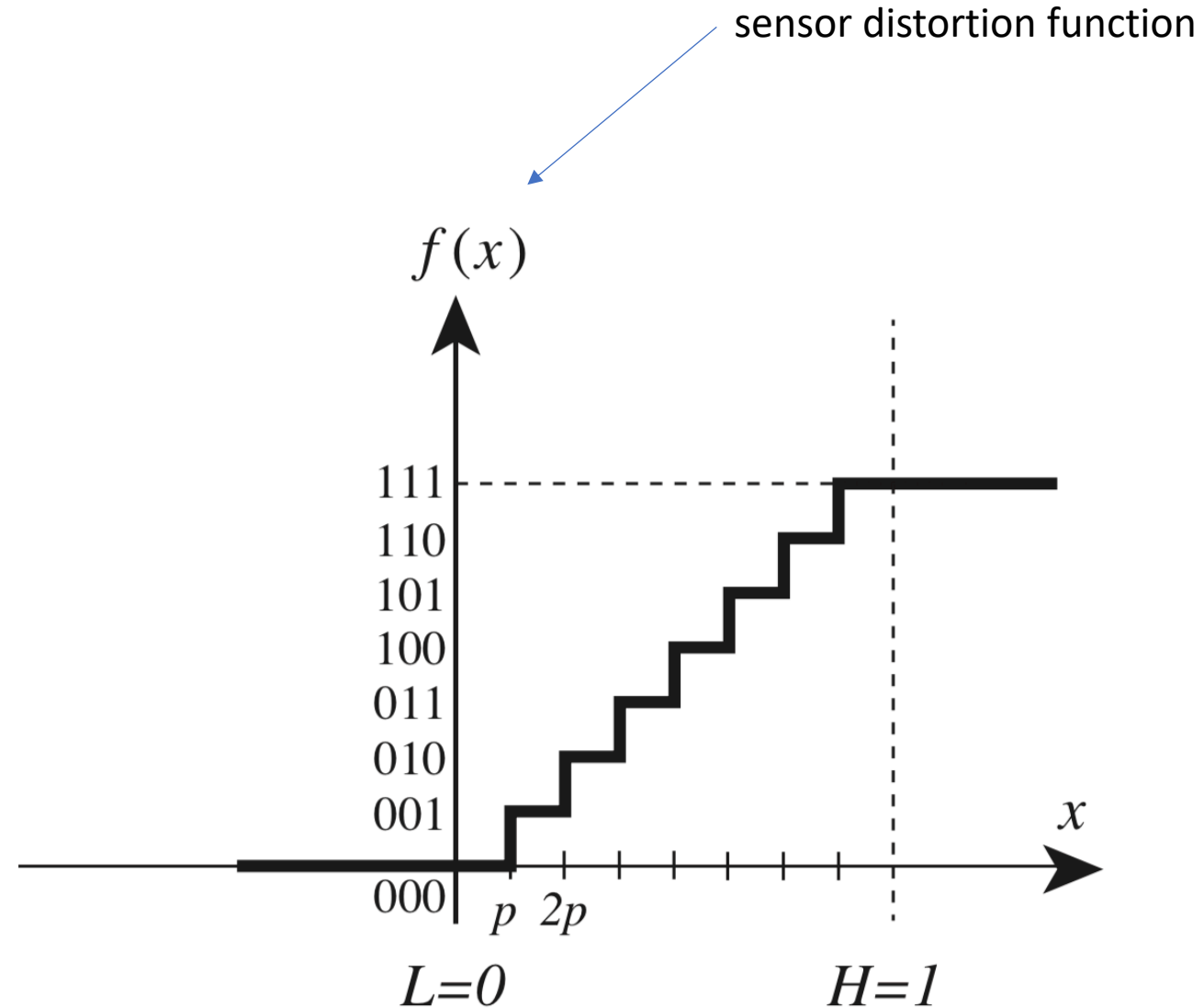

One-bit Sensor and Actuator

Analog Comparator sensor:

$$f(x) = \begin{cases} 0 & \text{if } x \leq K \\ 1 & \text{otherwise} \end{cases}$$

Bang-bang Controller: an actuator with one-bit digital actuation signal to drive the actuator

Noise

It is the part of a signal that we do not want

$$n(t) = x'(t) - x(t).$$

If noise is a side effect of the fact that the sensor is not measuring exactly what we want, than:

$$n(t) = f(x(t)) - x(t)$$

The **root mean square (RMS)**, $N \in \mathbb{R}_+$, characterizes how much noise there is in a measurement, is:

$$\lim_{T \rightarrow \infty} \sqrt{\frac{1}{2T} \int_{-T}^T (n(\tau))^2 d\tau}$$

Sampling

A physical quantity $x(t)$ is a function of time t . A digital sensor will sample the physical quantity at particular points in time to create a discrete signal.

In **uniform sampling**, there is a fixed time interval T between samples; T is called the **sampling interval**.

The resulting signal $s : Z \rightarrow R$ is:

$$s(n) = f(x(nT))$$

The **sampling rate** is $\frac{1}{T}$, which has units of samples per second, often given as Hertz (Hz), cycles per second.

Aliasing

There are many distinct functions x that when sampled will yield the same signal s

E.g. a sinusoid at 1 kHz taken at 8,000 samples per second are the same as samples of a 9 kHz sinusoid taken at 8,000 samples per second.

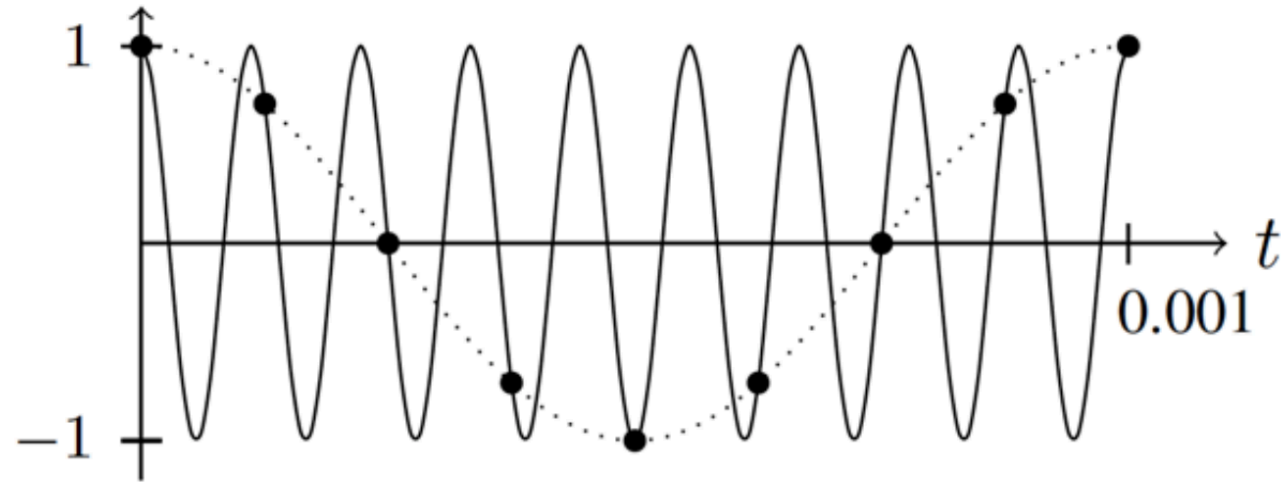

Careful modeling of the signal sources and analog signal conditioning or digital oversampling are necessary to counter the effect.

Harmonic Distortion

When the sensitivity depends on the magnitude of the signal

$$f(x) = a x + b + d_2 x^2$$

Second harmonic distortion



Frequency-selective filtering

Noise and harmonic distortion often have significant differences from the desired signal. We can exploit those differences to reduce or even eliminate the noise or distortion.

The **frequency selective filtering** relies on Fourier theory, which states that a signal is an additive composition of sinusoidal signals of different frequencies.

$$y = S(x') = S(x + n) = S(x) + S(n),$$

That is, the filter S should do minimal damage to the desired signal x while filtering out as much as possible of the noise.

$$S(x) \approx x$$

Example:

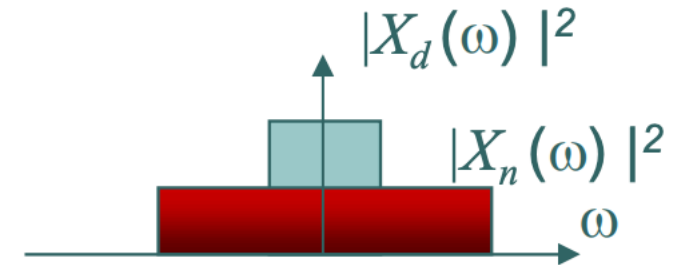

Filter:

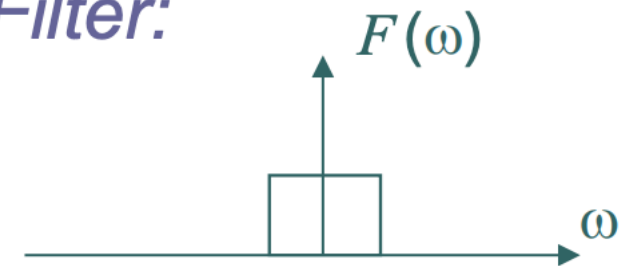

Filtered signal:

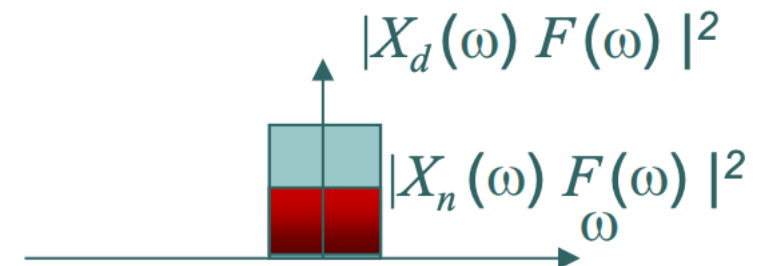

The Accelerometer Sensor

The most common design measures the distance between a plate fixed to the platform and one attached by a spring and damper.

An accelerometer, therefore, can measure the tilt (relative to gravity) of the fixed frame. Any acceleration experienced by the fixed frame will add or subtract from this measurement.

It can be challenging to separate these two effects, gravity and acceleration. The combination of the two is what we call [proper acceleration](#).

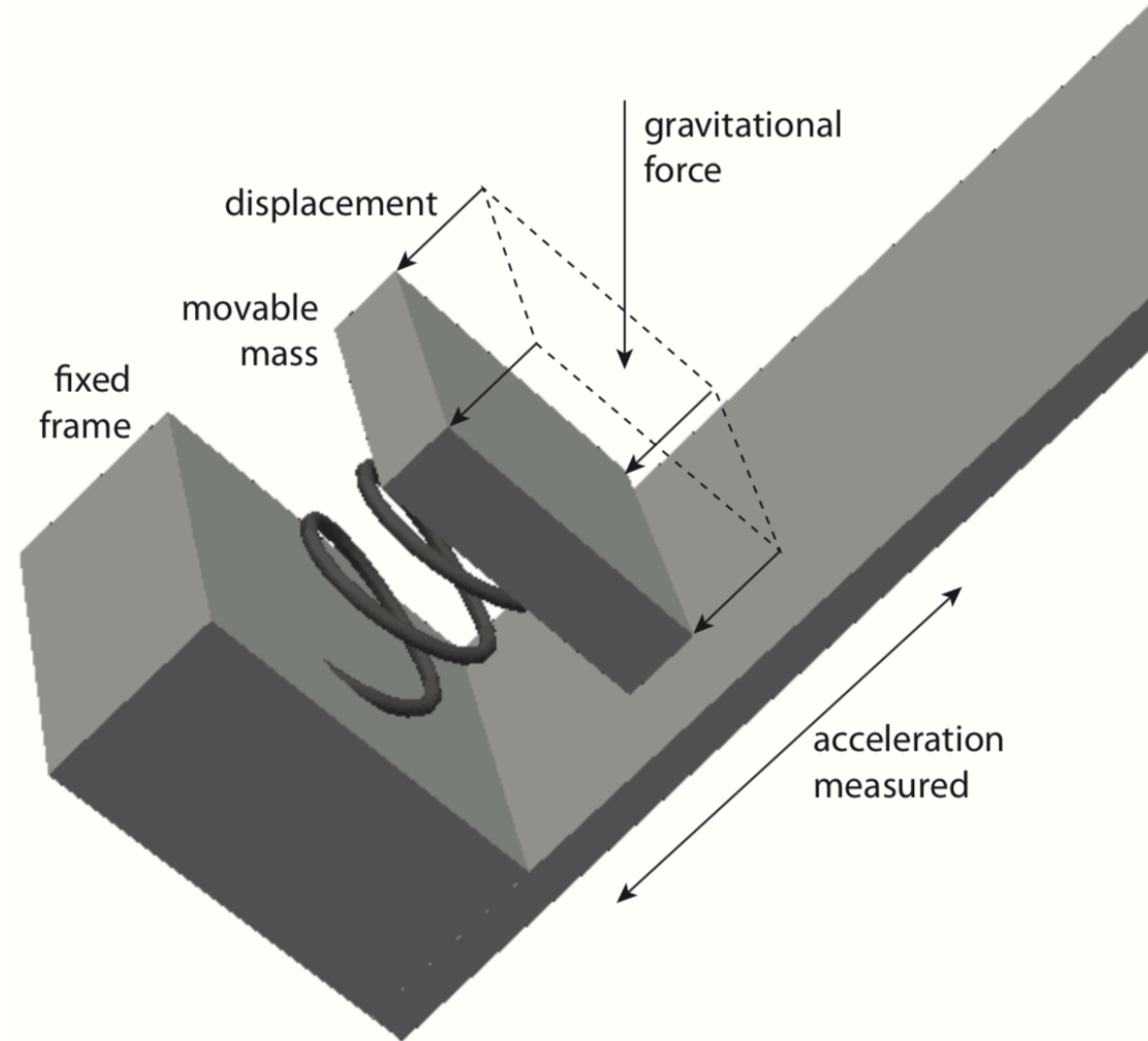

Accelerometer

Given a measurement x of acceleration over time, it is possible to determine the velocity and location of an object.

$$p(t) = p(0) + \int_0^t v(\tau) d\tau,$$

$$v(t) = v(0) + \int_0^t x(\tau) d\tau.$$

Note, however, that if there is a non-zero bias in the measurement of acceleration, $x(t) + n(t)$, then $p(t)$ will have an error (**drift**) that grows proportionally to t^2 .

A solution is periodically reset position using e.g. Global Positioning System (**GPS**).

Basics of GPS

- Commercial GPS systems provide (GPS) coordinates of a vehicle within $\pm 2\text{m}$ accuracy, this is not enough for autonomous driving
- Differential GPS receivers provide decimeter level accuracy
- GPS gives information about current time, latitude, longitude, and altitude
- Often GPS data is used as “observations” along with an IMU-based inertial navigation system (INS) to localize the vehicle

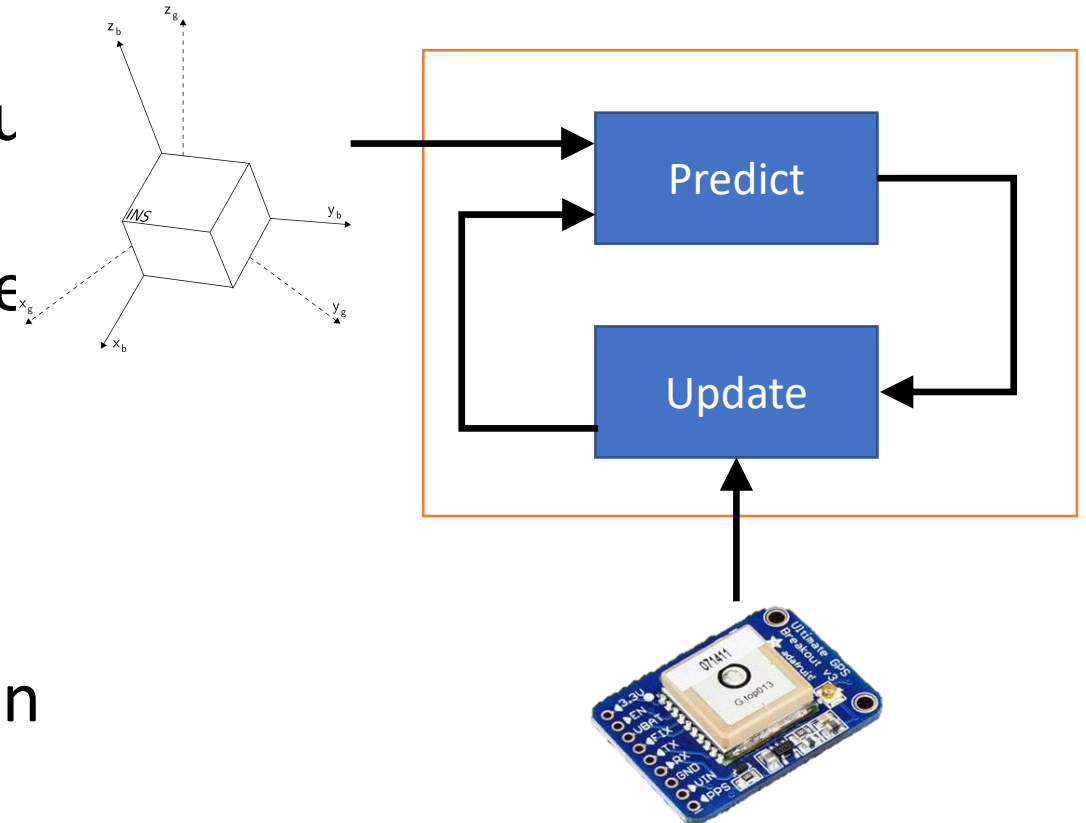

Basics of Radar

- Frequency Modulated Continuous Wave Doppler radar is popular
- Main idea is to compute the distance to the obstacle in a given direction by comparing transmitted and received signals
- Allows estimating both distance and relative velocity
- Radars may require additional signal processing to give precise answers when the environment is dusty, rainy, or foggy.
- Forward-facing radars estimate relative position/velocity of lead vehicle
- Surround ultrasonic sensors can help create environment models (Tesla approach)

The Motor Control Actuator

A motor applies a **torque** (angular force) to a load proportional to the current through the motor windings. It might be tempting, therefore, to apply a voltage to the motor proportional to the desired torque.

Problems:

- Not exceed the current limits of the DAC. Most DACs cannot deliver much power, and require a power amplifier between the DAC and the device being powered.
- The input to a power amplifier has high impedance, meaning that at a given voltage, it draws very little current, so it can usually be connected directly to a DAC. The output, however, may involve substantial current.
- Power amplifiers with good linearity (where the output voltage and current are proportional to the input voltage) can be expensive, bulky, and inefficient (the amplifier itself dissipates significant energy).

Pulse-Width Modulation (PWM)

To simplify delivering power, but only for devices that tolerates rapid on-off controls (“bangbang” control).

PWM signal switches between a high level and a low level at a specified frequency

It holds the signal high for a fraction of the cycle period. This fraction is called the **duty cycle**

Making a switch that tolerates high currents is much easier than making a power amplifier.

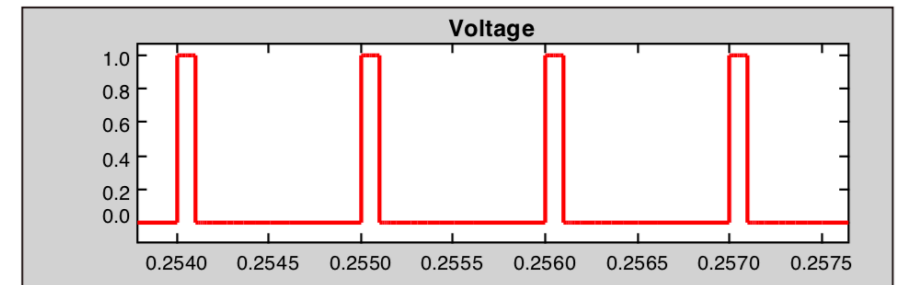
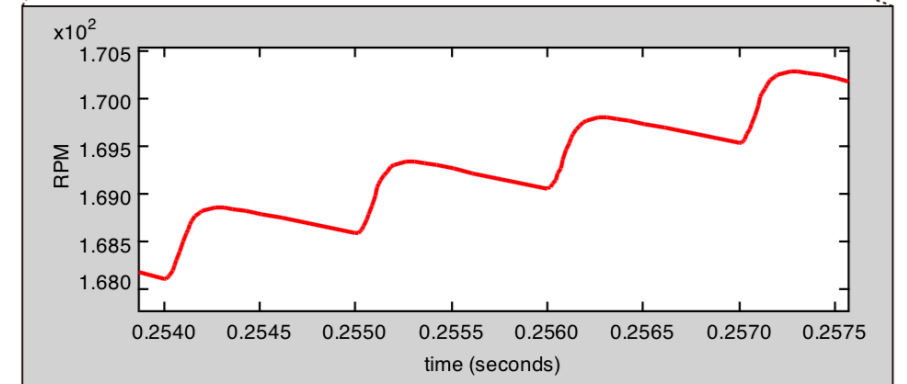
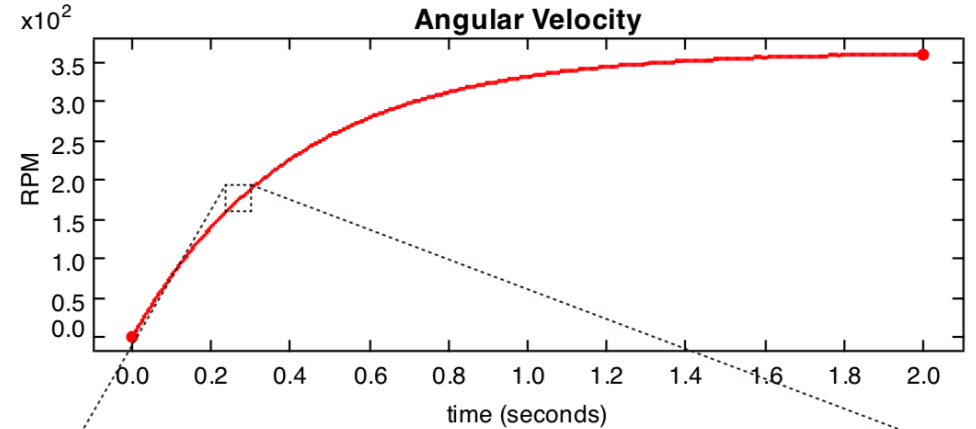

PWM



Model of an DC Motor

Electrical Model:

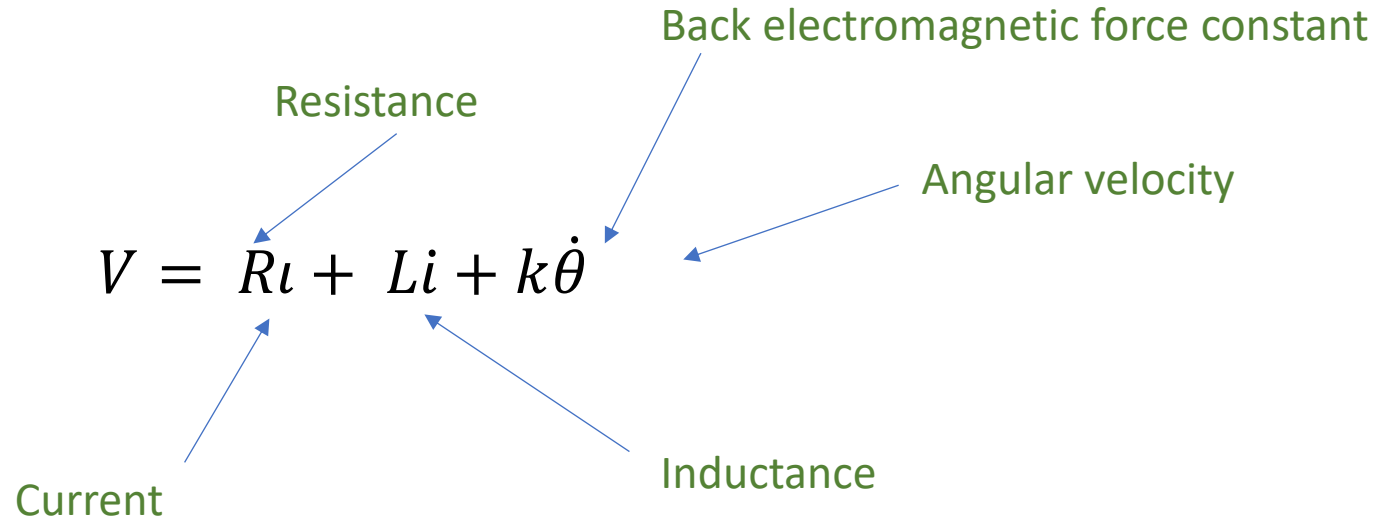
$$V = Ri + Li + k\dot{\theta}$$

Resistance

Back electromagnetic force constant

Angular velocity

Inductance

Current

Mechanical Model:

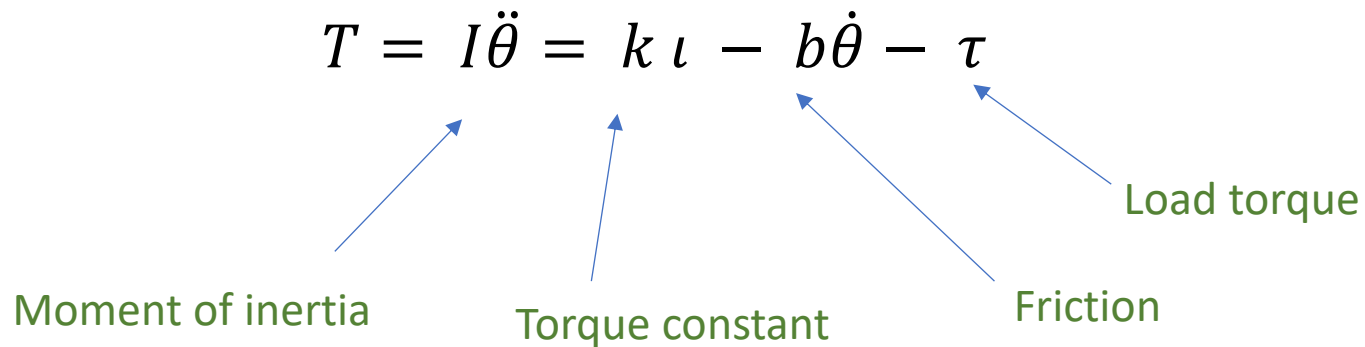
$$T = I\ddot{\theta} = k\iota - b\dot{\theta} - \tau$$

Moment of inertia

Torque constant

Friction

Load torque