

### Molecular states

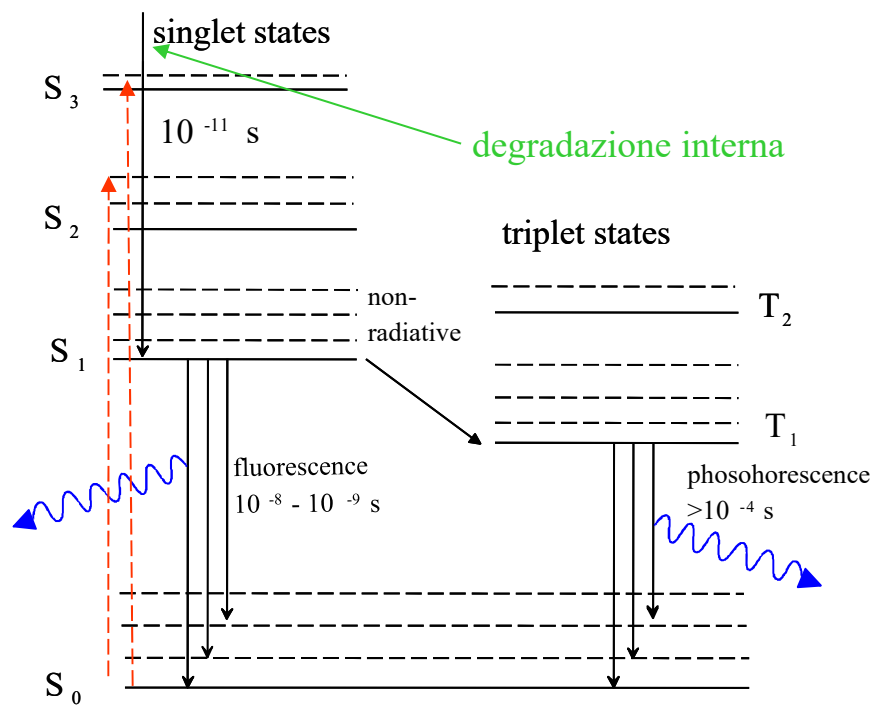

# Scintillatori organici

## Proprietà di alcuni scintillatori organici

materiale	densità (g/cm <sup>3</sup> )	n	$\lambda$ (nm)	$\tau$ (ns)	scint. rel antr	H/C	note	yeild/ NaI
naphthalene	1.15	1.58	348	11	11	0.800	monocrist.	
anthracene	1.25	1.59	448	30-32	100	0.714	monocrist.	0.5
NE 102 A	1.032	1.58	425	2.5	65	1.105	Nucl. Ent.	
NE 104	1.032	1.58	405	1.8	68	1.100	Nucl. Ent.	
NE 110	1.032	1.58	437	3.3	60	1.105	Nucl. Ent.	
BC 412	1.032	1.58	434	3.3	60	1.104	Bicron	
BC 414	1.032	1.58	392	1.8	68	1.110	Bicron	
BC 416	1.032	1.58	434	4.0	50	1.110	Bicron	

# Scintillatori inorganici

scintillatore	densità (g/cm <sup>3</sup> )	indice rifrazione	lunghezza d'onda (nm)	costante di tempo (μs)	scintillaz. (relativa a NaI(Tl))	note	fotoni/MeV
NaI	3.67	1.78	303	0.06	190		
NaI(Tl)	3.67	1.85	410	0.25	100	a 80 K	4x10 <sup>4</sup>
CsI	4.51	1.80	310	0.01	6	a 80 K	
CsI(Tl)	4.51	1.80	565	1.0	45	a 80 K	1.1x10 <sup>4</sup>
<sup>6</sup> LiI(Eu)	4.06	1.96	470-485	1.4	35	a 80 K	1.4x10 <sup>4</sup>
BaF <sub>2</sub>	4.88	1.49	190/220 310	0.0006 0.63	5 15		6.5x10 <sup>3</sup> 2x10 <sup>3</sup>
Bi <sub>4</sub> Ge <sub>3</sub> O <sub>12</sub>	7.13	2.15	480	0.30	10		2.8x10 <sup>3</sup>
PbWO <sub>4</sub>	8.28	1.82	440,530				100
LAr	1.4	1.29	120-170	0.005/0.860		a 170 nm	
LKr	2.41	1.40	120-170	0.002/0.085		a 170 nm	
LXe	3.06	1.60	120-170	0.003/0.022		a 170 nm	4x10 <sup>4</sup>

**Table 7.1.** Physical properties of various commercial scintillators (data from Nuclear Enterprises scintillator catalog [7.1])

Scintillator	Type	Density	Refractive index	Melting softening or boiling point C <sup>a</sup>	Light output (% Anthracene)	Decay constant, main component [ns]	Wave-length of maximum emission [nm]	Content of loading element (% by wt.)	H/C No. of H atoms/ No. of C atoms	Principal applications	
Plastic	NE 102A	Plastic	1.032	1.581	75	65	2.4	423	1.104	$\gamma$ , $\alpha$ , $\beta$ , fast $n$	
	NE 104	Plastic	1.032	1.581	75	68	1.9	406	1.100	ultra-fast counting	
	NE 104B	Plastic	1.032	1.58	75	59	3.0	406	1.107	with BBQ light guides	
	NE 105	Plastic	1.037	1.58	75	46		423	1.098	dosimetry	
	NE 110	Plastic	1.032	1.58	75	60	3.3	434	1.104	$\gamma$ , $\alpha$ , $\beta$ , fast $n$ etc.	
	NE 111A	Plastic	1.032	1.58	75	55	1.6	370	1.103	ultra-fast timing	
	NE 114	Plastic	1.032	1.58	75	50	4.0	434	1.109	as for NE 110	
	NE 160	Plastic	1.032	1.58	80	59	2.3	423	1.105	use at high temperatures	
	Pilot U	Plastic	1.032	1.58	75	67	1.36	391	1.100	ultra fast timing	
Pilot 425	Plastic	1.19	1.49	100			425	1.6	Cherenkov detector		
Liquid	NE 213	Liquid	0.874	1.508	141	78	3.7	425		1.213	fast $n$ (P.S.D.)
	NE 216	Liquid	0.885	1.523	141	78	3.5	425		1.171	$\alpha$ , $\beta$ (internal counting)
	NE 220	Liquid	1.036	1.442	104	65	3.8	425	O 29%	1.669	internal counting, dosimetry
	NE 221	Gel	1.08	1.442	104	55	4	425		1.669	$\alpha$ , $\beta$ (internal counting)
	NE 224	Liquid	0.877	1.505	169	80	2.6	425		1.330	$\gamma$ , fast $n$
	NE 226	Liquid	1.61	1.38	80	20	3.3	430		0	$\gamma$ , insensitive to $n$
	NE 228	Liquid	0.71	1.403	99	45		385		2.11	$n$
	NE 230	Deuterated liquid	0.945	1.50	81	60	3.0	425	D 14.2%	0.984	(D/C) special applications
	NE 232	Deuterated liquid	0.89	1.43	81	60	4	430	D 24.5%	1.96	(D/C) special applications
	NE 233	Liquid	0.874	1.506	117	74	3.7	425		1.118	$\alpha$ , $\beta$ (internal counting)
	NE 235	Liquid	0.858	1.47	350	40	4	420		2.0	large tanks
	NE 250	Liquid	1.035	1.452	104	50	4	425	O 32%	1.760	internal counting, dosimetry
Loaded liquid	NE 311 & 311A	B loaded liquid	0.91	1.411	85	65	3.8	425	B 5%	1.701	$n$ , $\beta$
	NE 313	Gd loaded liquid	0.88	1.506	136	62	4.0	425	Gd 0.5%	1.220	$n$
	NE 316	Sn loaded liquid	0.93	1.496	148.5	35	4.0	425	Sn 10%	1.411	$\gamma$ , x-rays
	NE 323	Gd loaded liquid	0.879	1.50	161	60	3.8	425	Gd 0.5%	1.377	$n$

Neutron (ZnS- type) and glass	NE 422 & 426	<sup>6</sup> Li-ZnS(Ag)	2.36		110	300	200	450	Li 5%	slow <i>n</i>
	NE 451	ZnS(Ag) plastic	1.443		110	300	200	450		fast <i>n</i>
	NE 901, 902, 903	Glass	2.64	1.58	c. 1200	28	20 & 60	395	Li 2.3%	<i>n</i> , $\beta$
	NE 904, 905, 906	Glass	2.5	1.55	c. 1200	25	20 & 58	395	Li 6.6%	<i>n</i>
	NE 907, 908	Glass	2.42	1.566	c. 1200	20	18 & 62	399	Li 7.5%	<i>n</i>
	NE 912, 913	Glass	2.3	1.55	c. 1200	25	18 & 55	397	Li 7.7%	<i>n</i> , $\beta$ (low background)
Crystal	Anthracene	Crystal	1.25	1.62	217	100	30	447	0.715	$\gamma$ , <i>a</i> , $\beta$ , fast <i>n</i>
	Stilbene	Crystal	1.16	1.626	125	50	4.5	410	0.858	fast <i>n</i> (P.S.D.), $\gamma$ , etc.
	NaI(Tl)	Crystal	3.67	1.775	650	230	230	413		$\gamma$ , x-rays
	NaI(pure)	Crystal	3.67	1.775	651	440 <sup>b</sup>	60 <sup>b</sup>	303 <sup>b</sup>		$\gamma$ , x-rays (fast counting)
	LiI(Eu)	Crystal	4.06	1.955	445	75	1200	475		<i>n</i>
	CsI(Tl)	Crystal	4.51	1.788	620	95	1100	580		heavy particles, $\gamma$ (P.S.D.)
	CsI(Na)	Crystal	4.51	1.787	621	150,190	650	420		heavy particles, $\gamma$ (P.S.D.)
	CsI(pure)	Crystal	4.51	1.788	621	500 <sup>b</sup>	600 <sup>b</sup>	c. 400 <sup>b</sup>		heavy particles, $\gamma$ (low energy)
	CaF <sub>2</sub> (Eu)	Crystal	3.17	1.443	1418	110	1000	435		$\beta$ , x-rays etc.
	CaWO <sub>4</sub>	Crystal	6.1	1.92	1535	36	6000	430		$\gamma$ (seldom used)
	ZnS(Ag)	Multi-crystal	4.09	2.356	1850	300	200	450		<i>a</i>
	ZnO(Ga)	Multi-crystal	5.61	2.02	1975	90	1.48	385		<i>a</i>

<sup>a</sup> Although NE 160 begins to soften very slightly at approximately 80°C, it retains its shape up to at least 150°C unlike other plastic scintillators as NE 102A.

<sup>b</sup> At liquid nitrogen temperature.

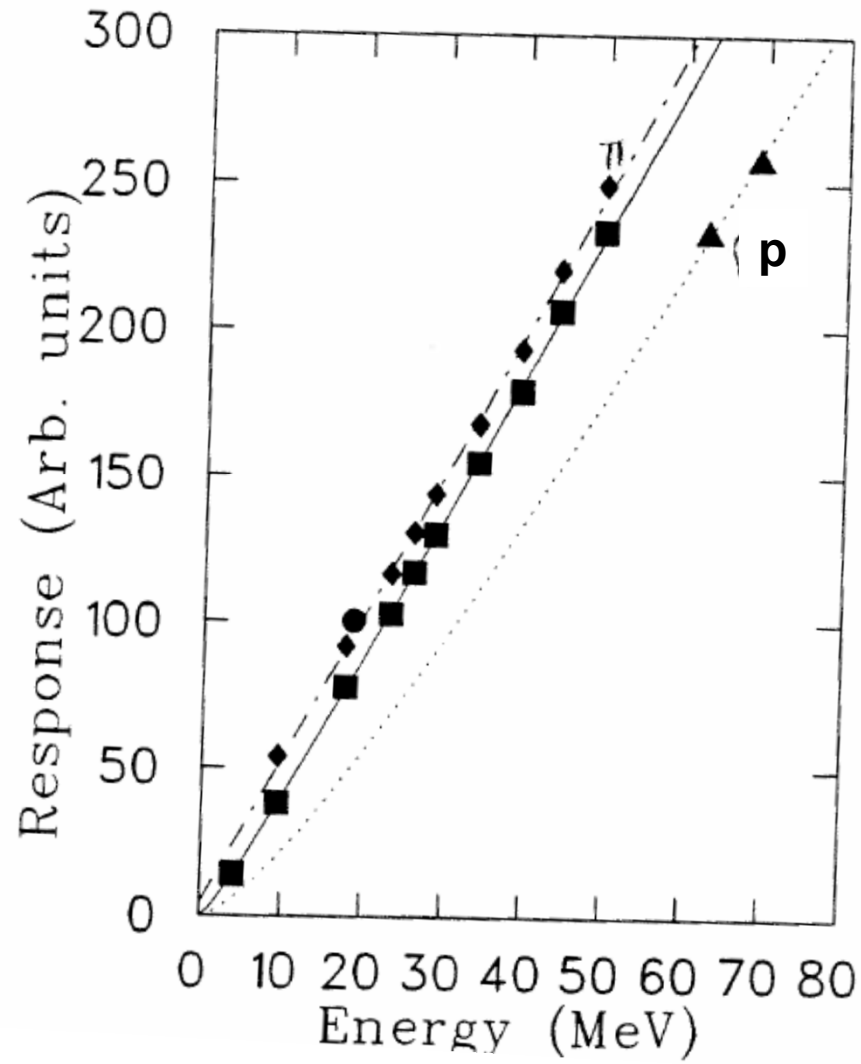

Lines: Birks fits

■  $\pi$ ; • positron; ♦  $\pi$  + dec  $\mu$ ;

NE-102

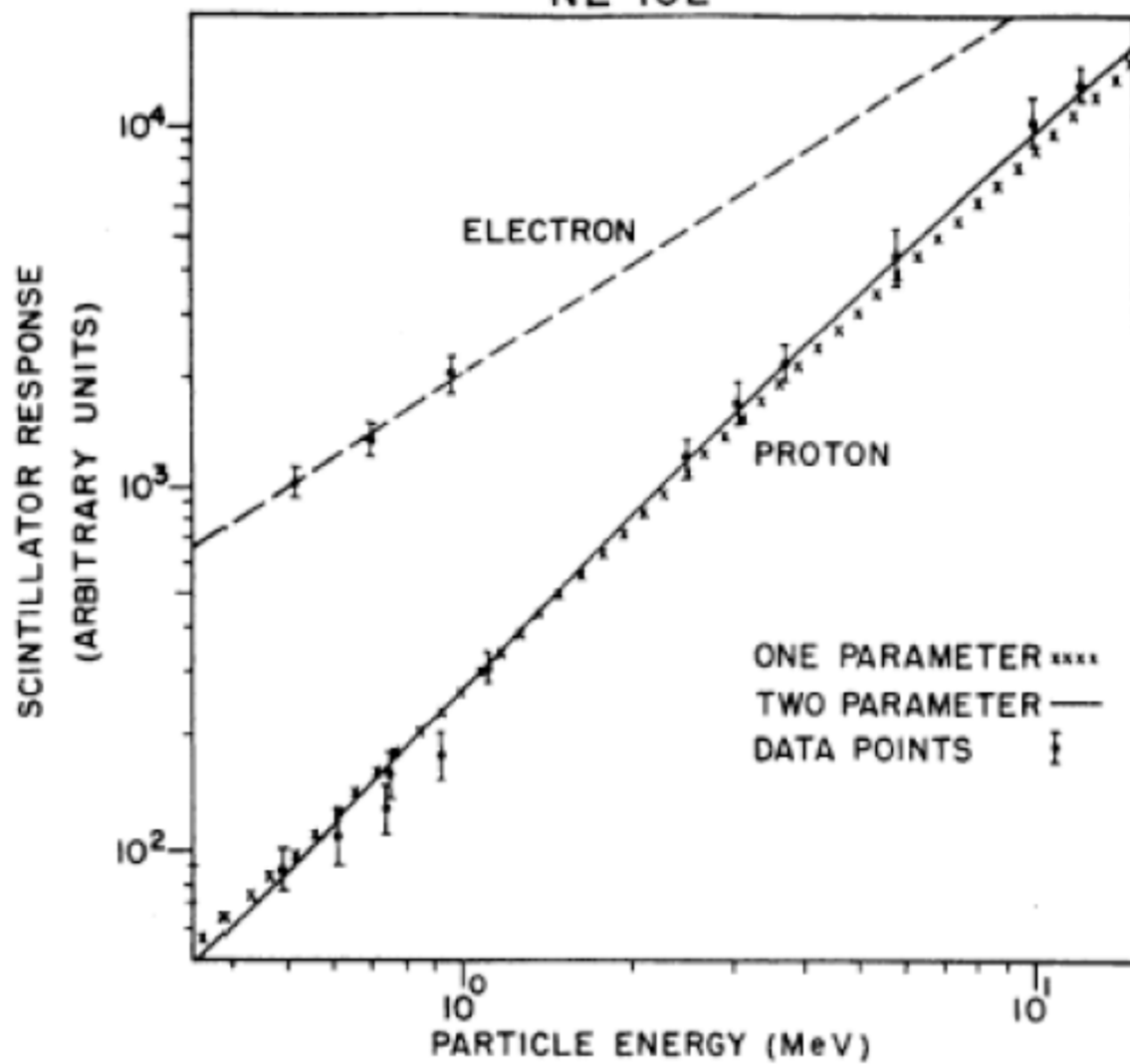





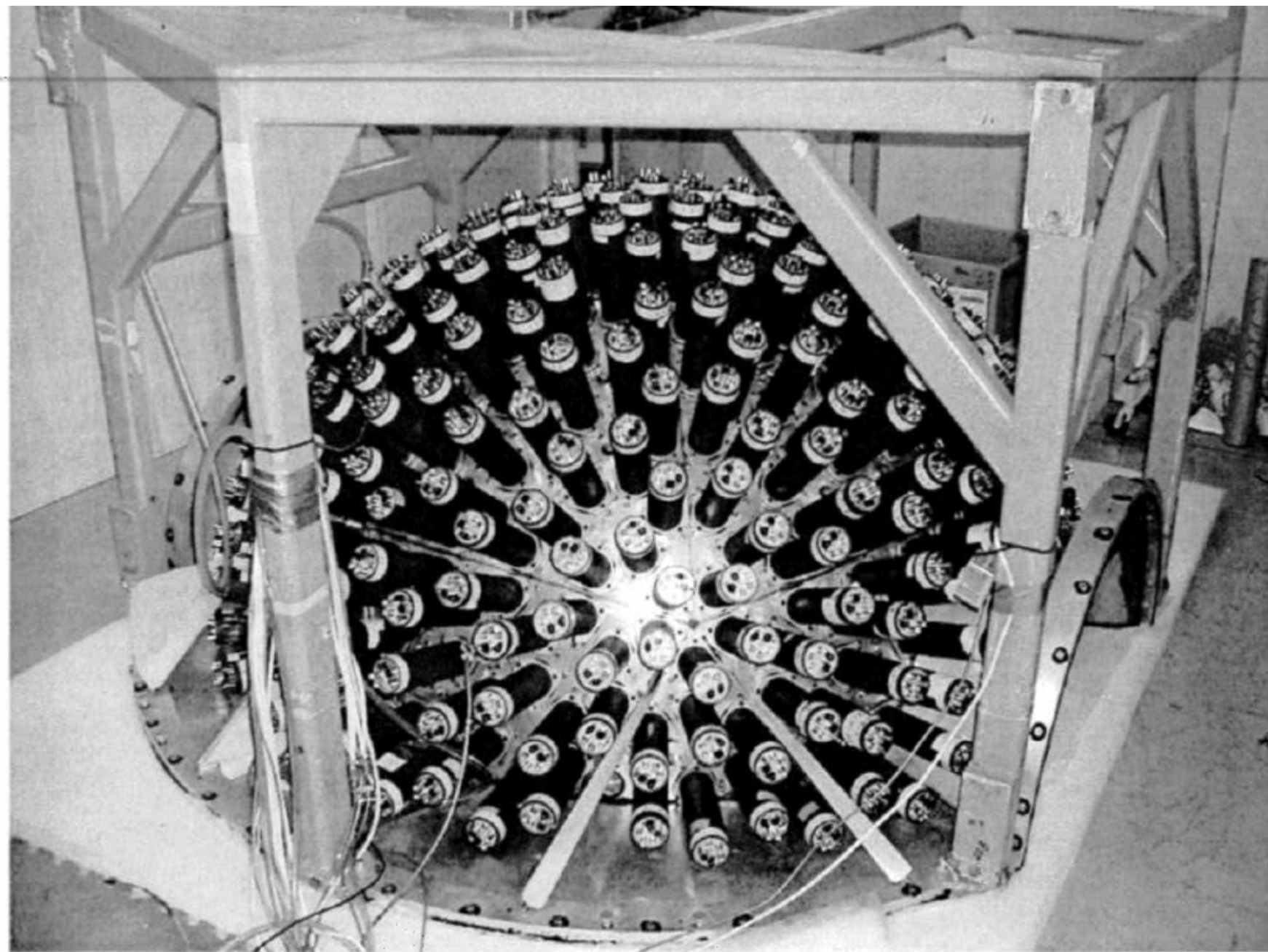



Figura 5.8: *Setup* sperimentale per il *test* del prototipo del telescopio  $\pi/\mu$ . Le distanze non sono in scala.



Figura 5.9: Distribuzione di TOF tra i contatori  $S_{-1}$  ed  $S_0$  lungo un percorso di  $465\text{ cm}$  per un fascio positivo di  $146.5\text{ MeV}/c$ . Sono mostrati i tagli a  $3\sigma$  operati con lo scopo di ottenere dei

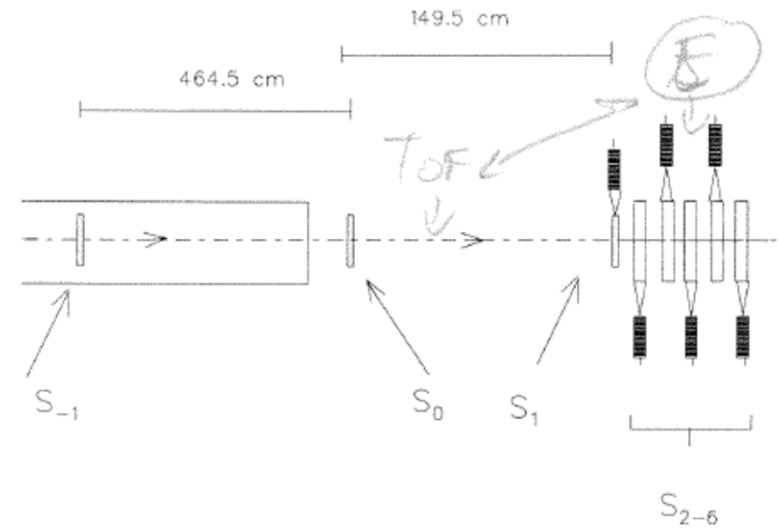

ADC 1 vs TDC 2 vs counts

Figura 4.13: Distribuzione di, nell'ordine, elettroni, muoni e pioni rispetto a due degli otto parametri forniti dal prototipo. La popolazione degli elettroni ha subito un precedente taglio software. Run a  $90MeV/c$

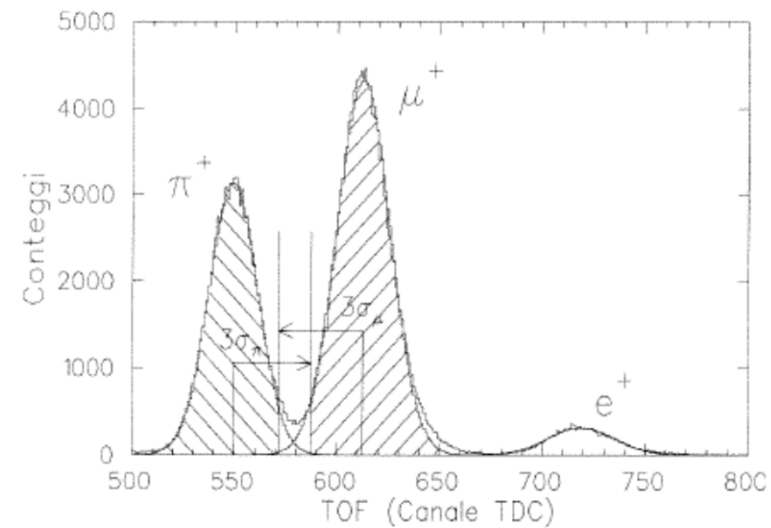
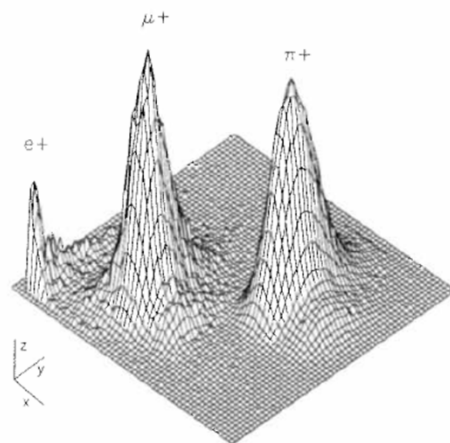
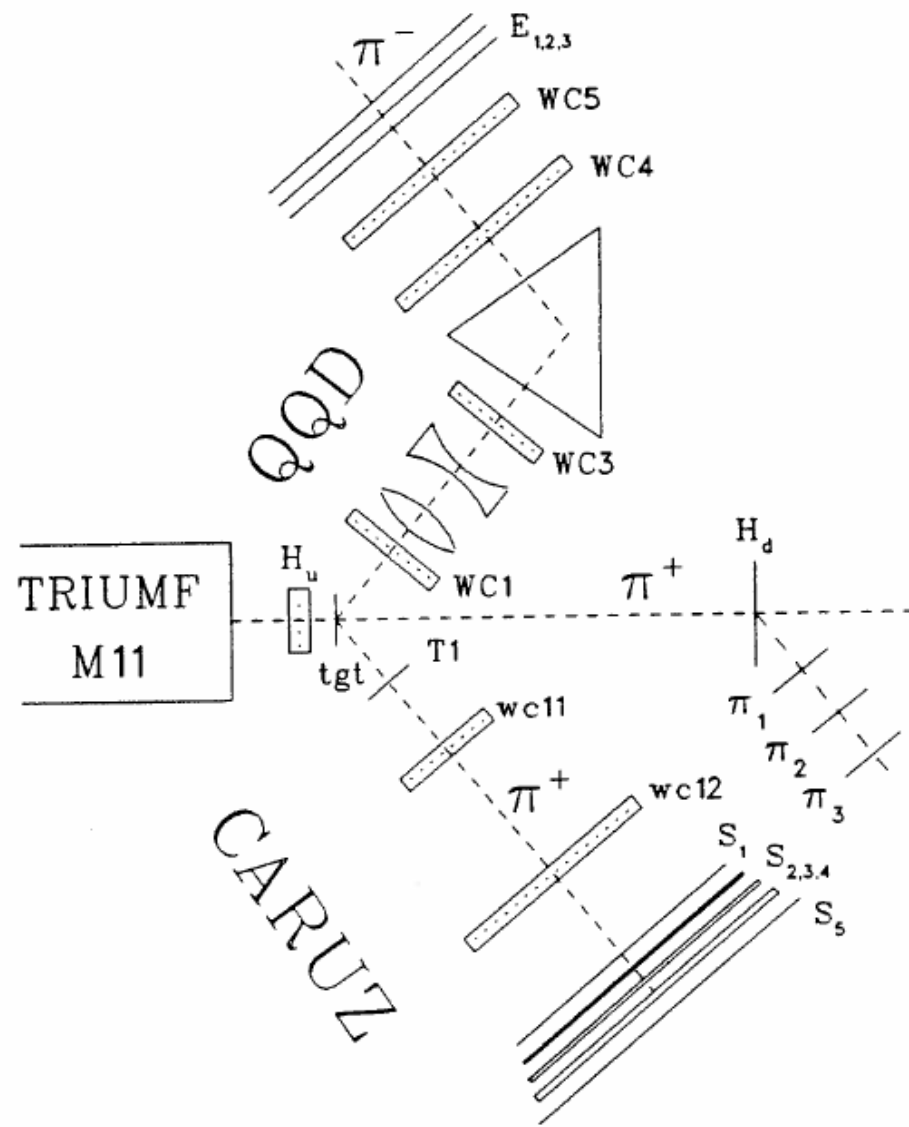

spettro pulito

NaI(Tl)

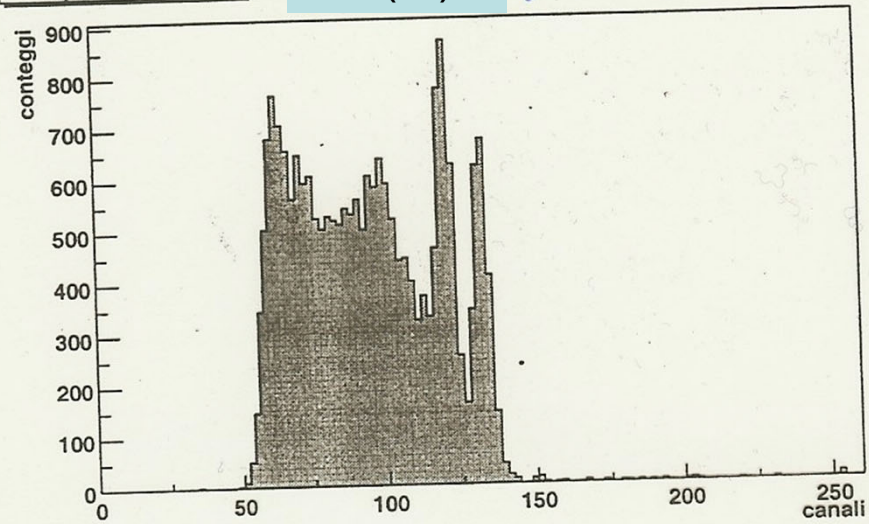

adc plastico

Plastic scint.

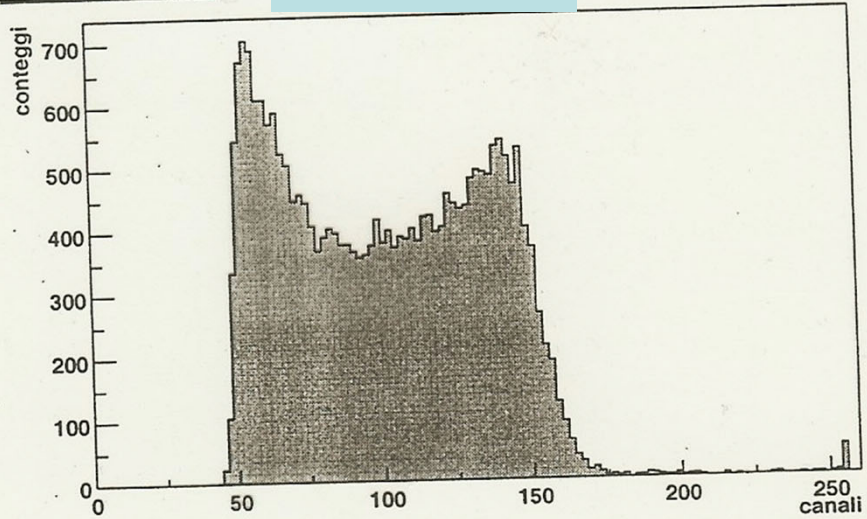

# $\Delta E$ vs E with CsI(Tl)

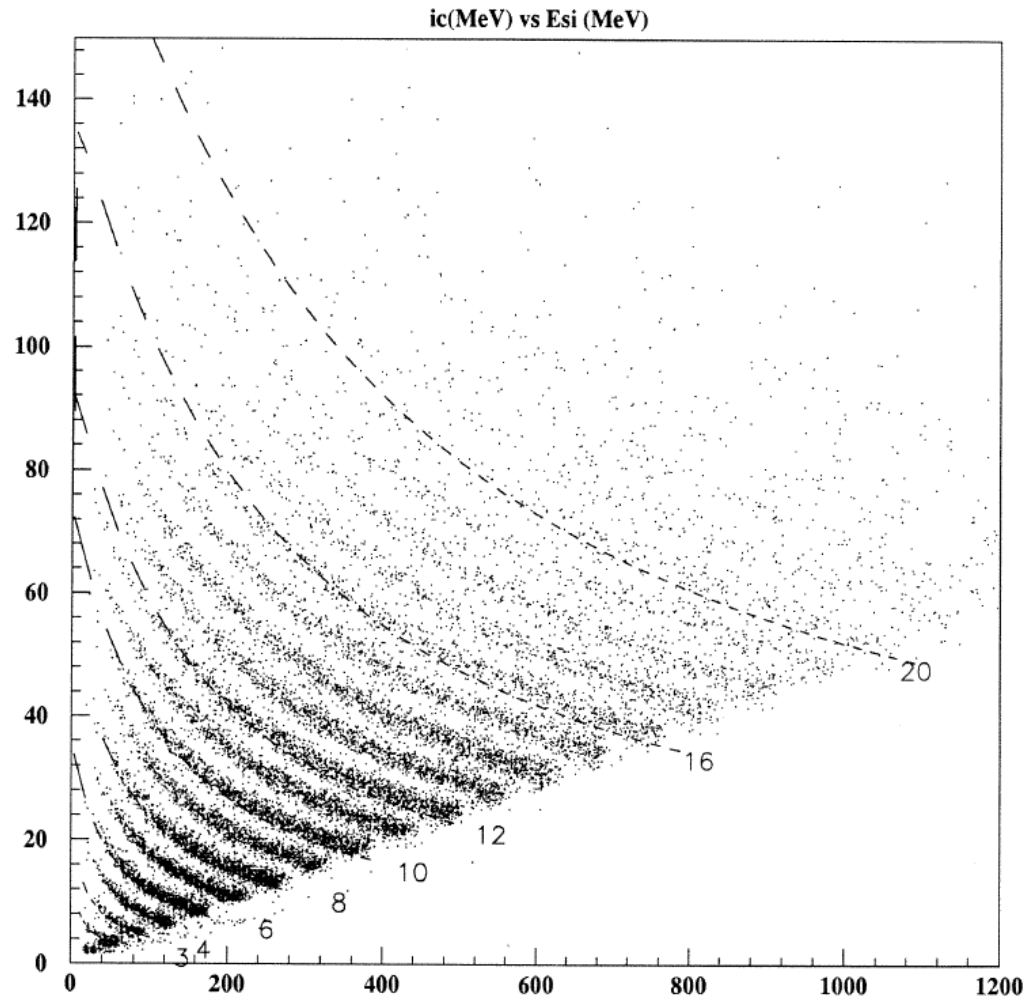



Figura 8.8: Matrice costruita con le energie rilasciate nel Silicio e nello Ioduro di Cesio. L'energia nel Silicio è stata ottenuta dalla calibrazione del segnale ad alta amplificazione, che permette la risoluzione isotopica. Per controllare l'assegnazione in massa, abbiamo indicato con colori diversi i frammenti corrispondenti alle diverse specie isotopiche.

Gamma cameras, Scintigraphy, PET:  
Inorganic scintillators (NaI(Tl))

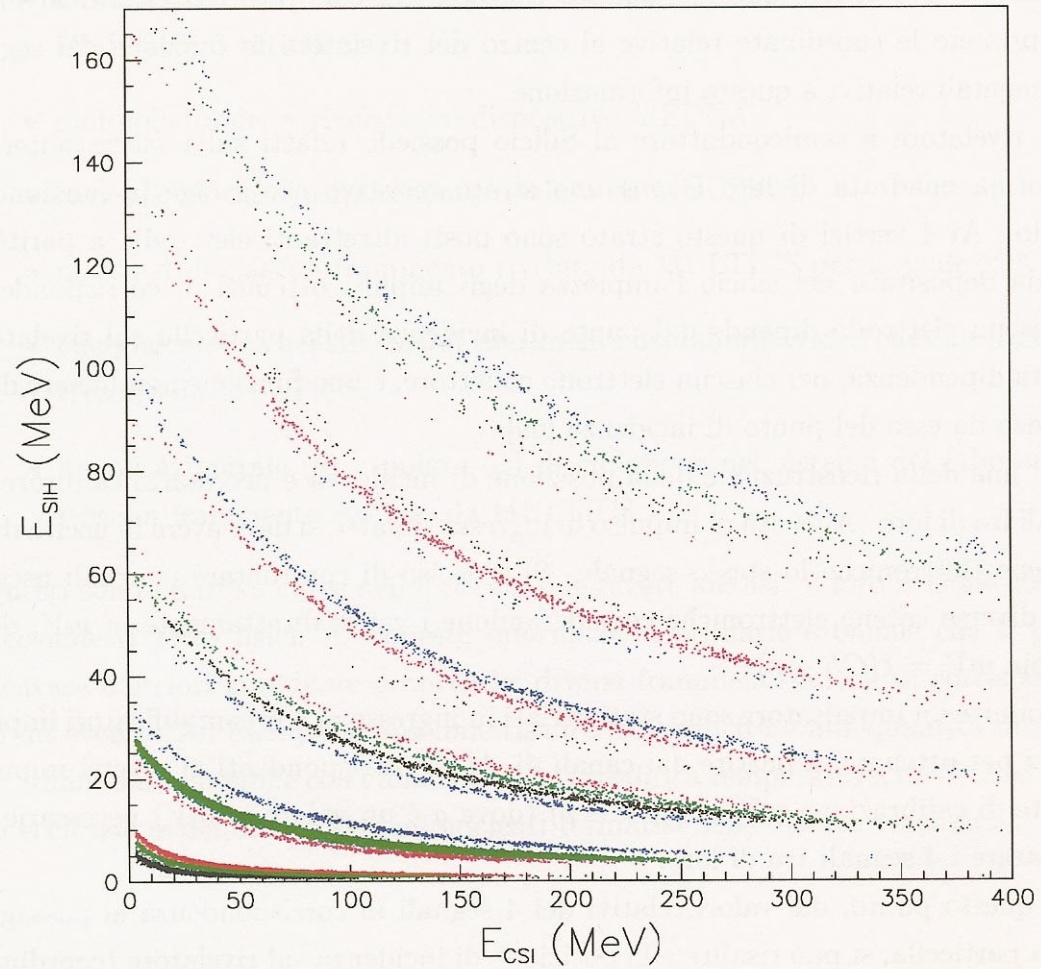

## Medical Imaging – Positron Emission Tomography

(thanks to Bill Moses, Life Sciences Div. LBNL)

What is Positron Emission Tomography (PET)?

- Patient injected with drug having  $\beta^+$  emitting isotope.
- Drug localizes in patient.
- Isotope decays, emitting  $\beta^+$ .
- $\beta^+$  annihilates with  $e^-$  from tissue, forming back-to-back 511 keV photon pair.

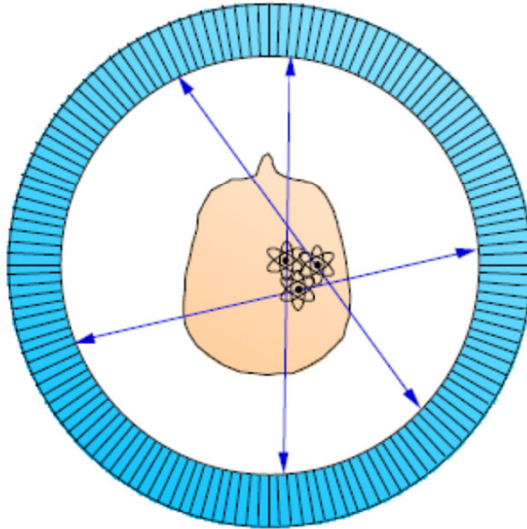

- 511 keV photon pairs detected via time coincidence.
- Positron lies on line defined by detector pair (a *chord*).

Forms planar image of a "slice" through the patient.

## Time-of-Flight Tomograph

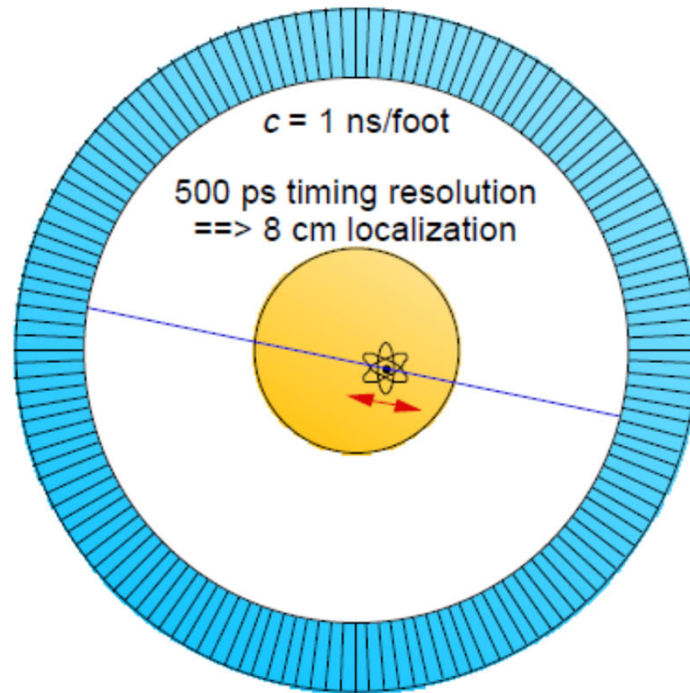

- Utilize difference in time of arrival between the two detectors
- Can localize source along line of flight
- Time-of-flight information reduces noise in images

However,

- Difficult to control timing of all detectors
- More expensive

Typically used to augment "standard" PET to reduce background.

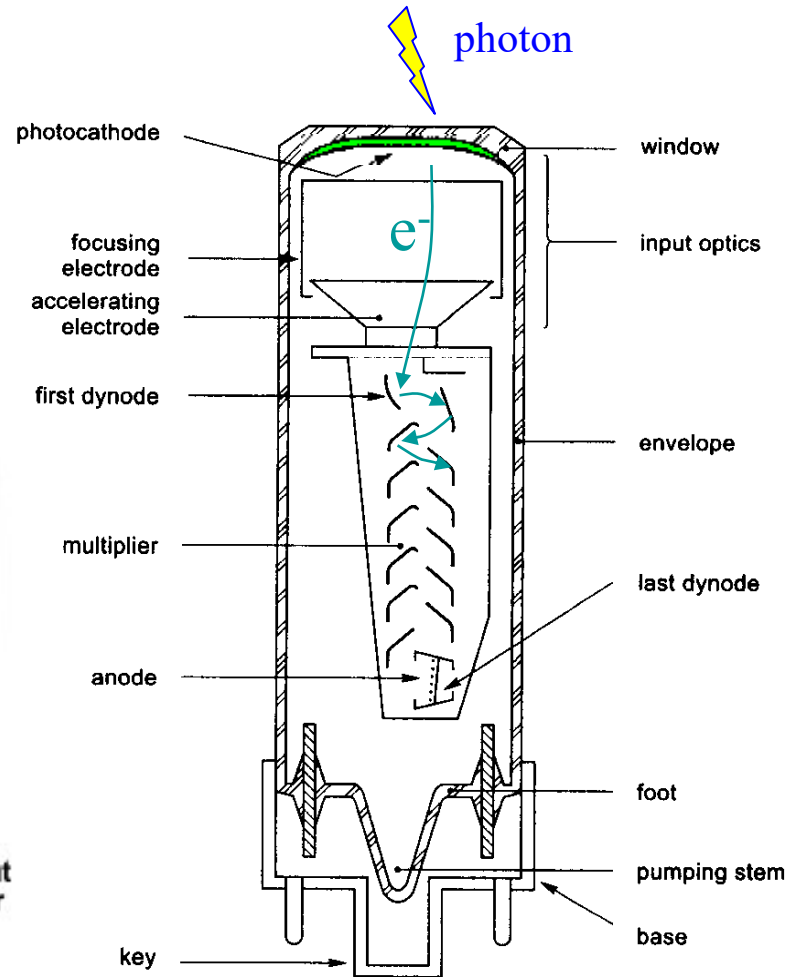
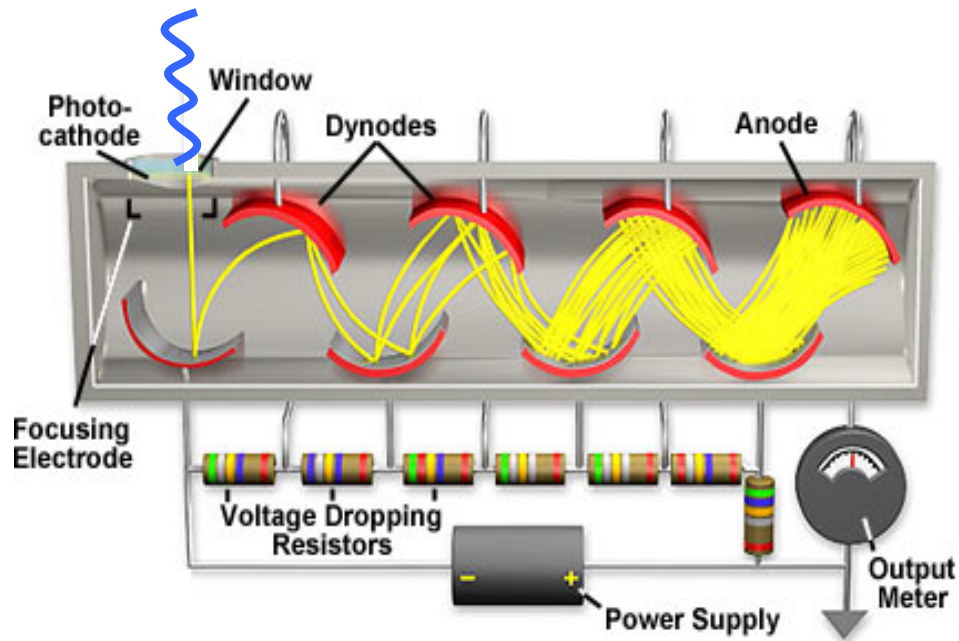

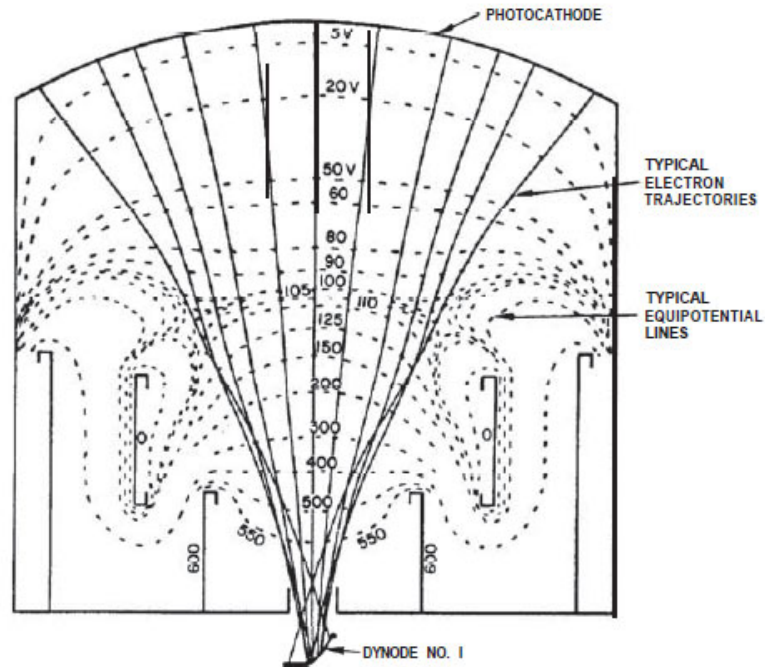
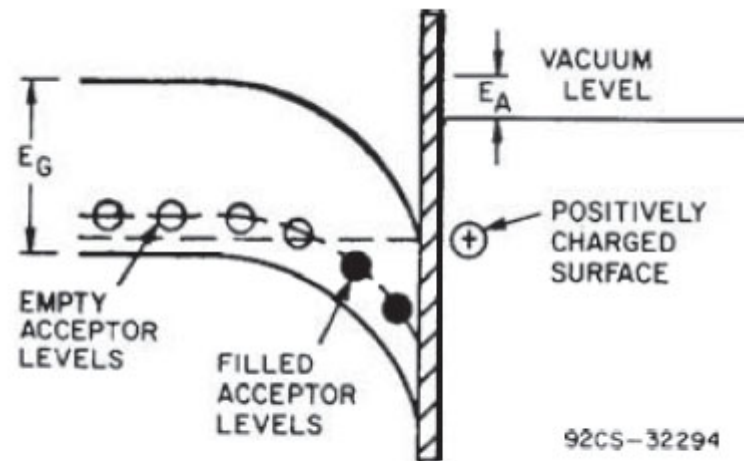

Fig. 27 - Cross section of a photomultiplier showing equipotential trajectories that were plotted by computer.



92CS-32294

Fig. 8 - Semiconductor energy-band model showing **negative** electron affinity.

Altezza d'impulso con dinodi di Cu-Be

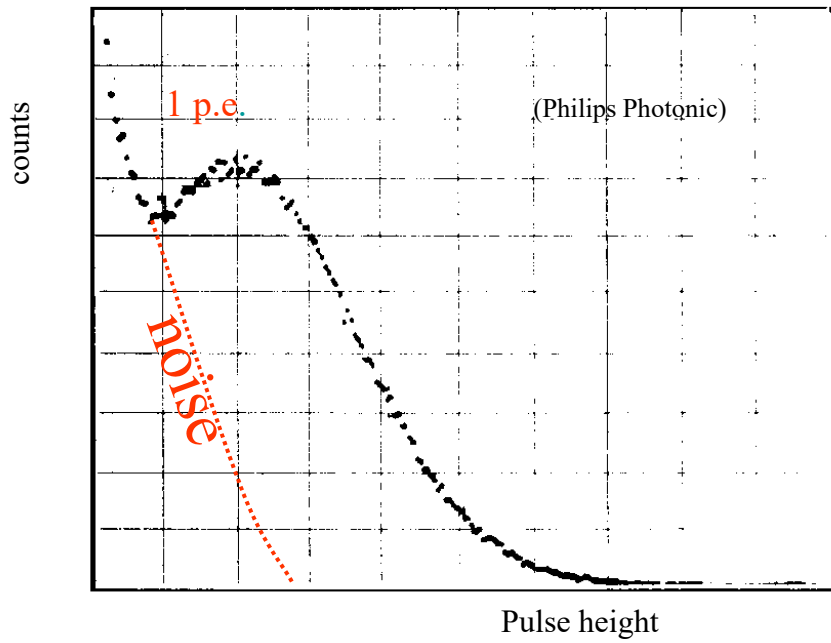

Altezza d'impulso con dinodi con affinità negativa (NEA)

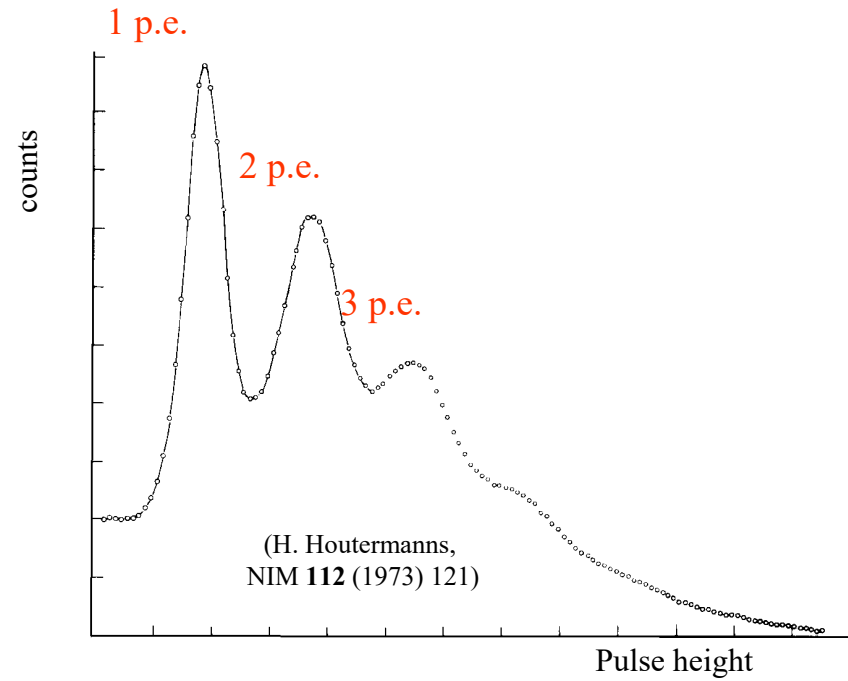

# Configurazione dei dinodi

traditional

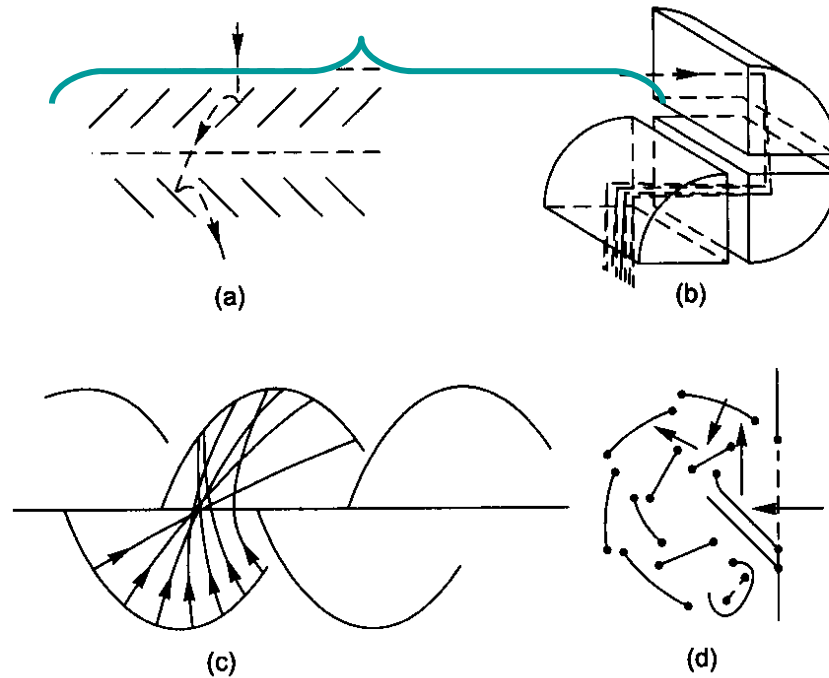

(Philips Photonics)

Dynode configurations: (a) venetian blind, (b) box, (c) linear focusing, (d) circular cage, (e) mesh and (f) foil

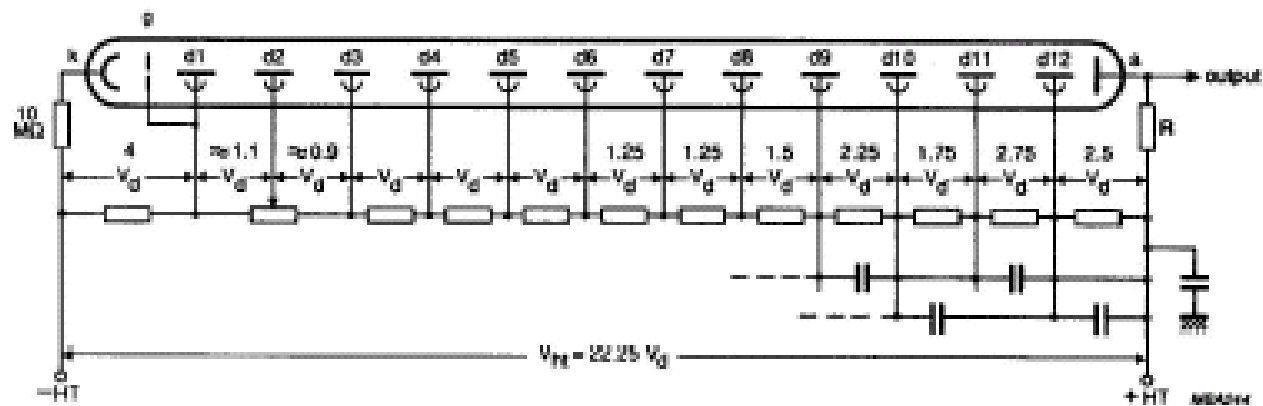
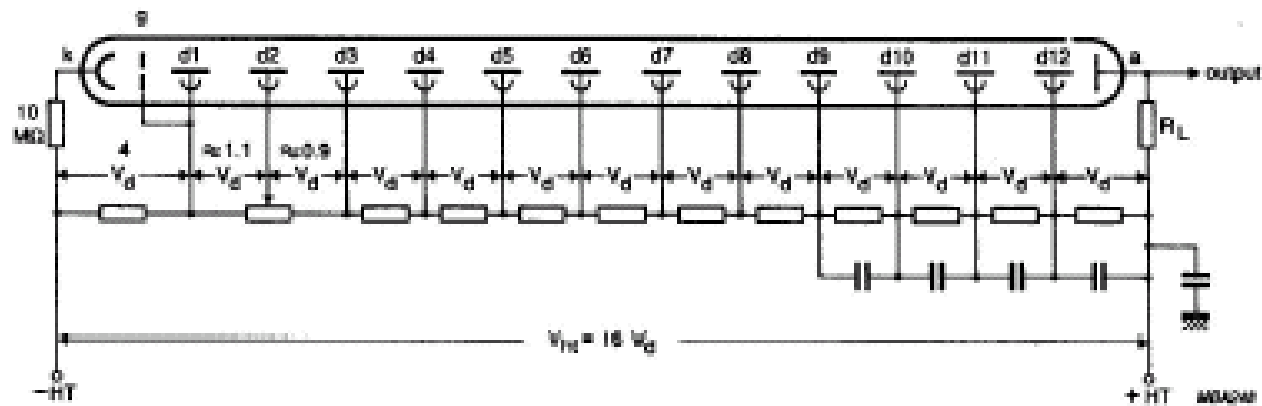

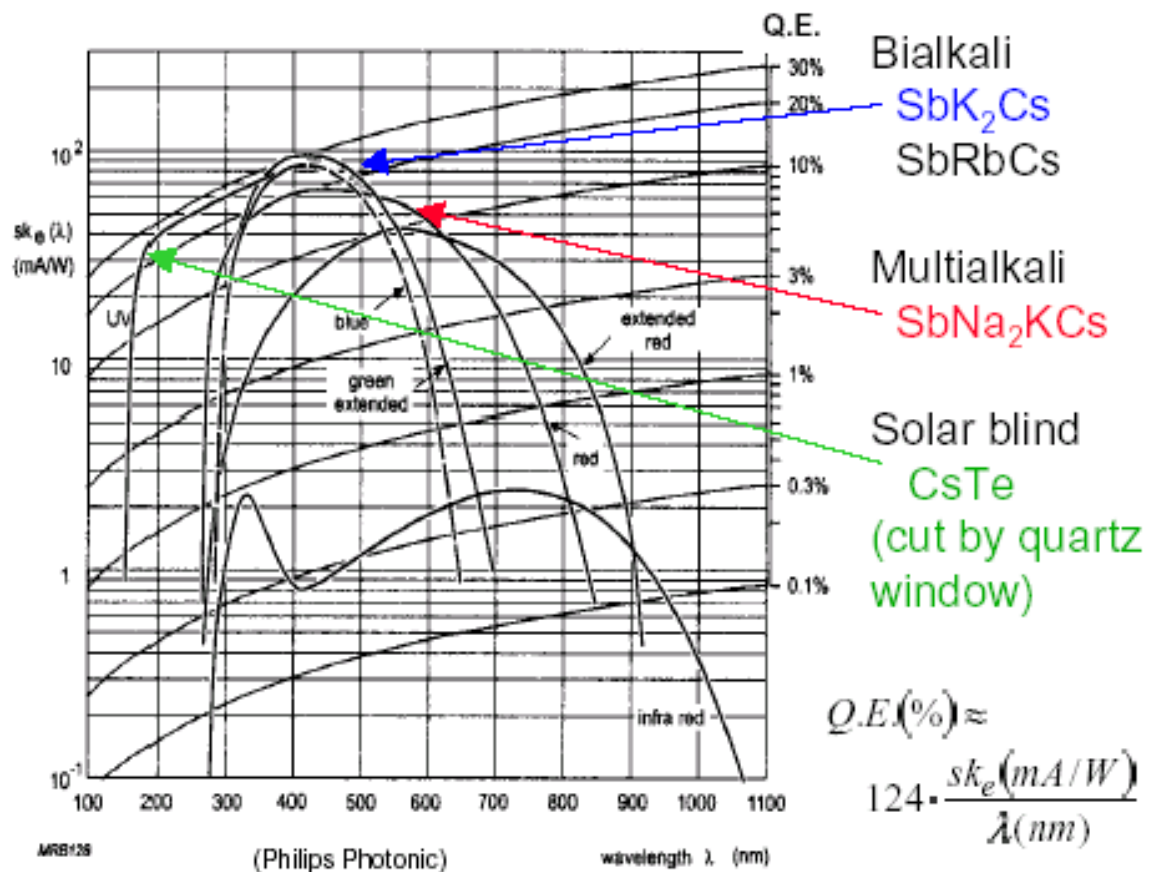



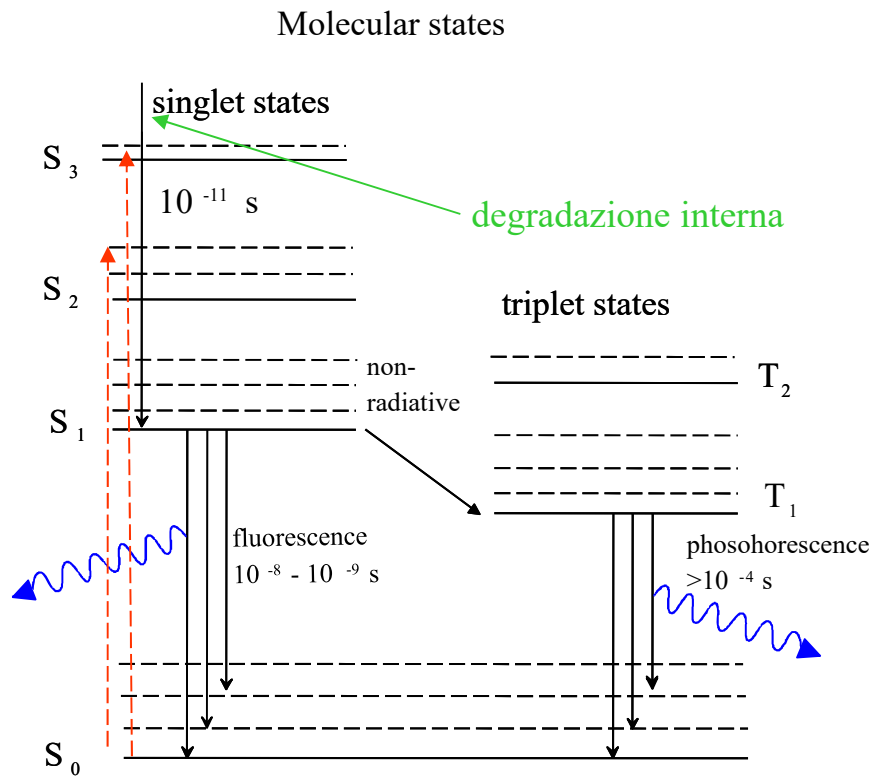

Scintillation is based on the 2  $\pi$  electrons of the C-C bonds.

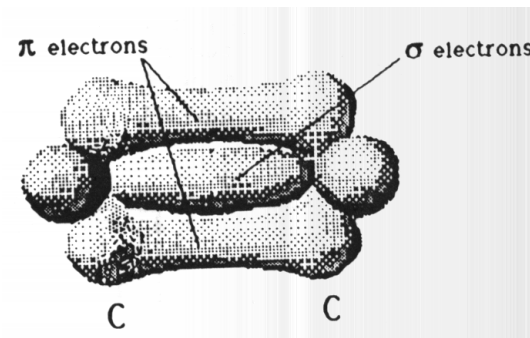

Emitted light is in the UV range.