

Università degli Studi di Trieste

Corso di Laurea Magistrale in
INGEGNERIA CLINICA

RICHIAMI DI BASI DI DATI

Corso di Informatica Medica

Docente Sara Renata Francesca MARCEGLIA



Dipartimento di Ingegneria e Architettura



UNIVERSITÀ
DEGLI STUDI DI TRIESTE



To create a database...



DATABASE LIFECYCLE



The database lifecycle is a complex process, usually composed by the following main phases:

1. Requirements collection and analysis
2. Conceptual database design
3. Choice of a Data Base Management System
4. Logical database design
5. Physical database design
6. Database implementation
7. Use & maintenance

DATABASE LIFECYCLE



The database lifecycle is a complex process, usually composed by the following main phases:

1. Requirements collection and analysis
- 2. Conceptual database design**
3. Choice of a Data Base Management System
4. Logical database design
5. Physical database design
6. Database implementation
7. Use & maintenance

CONCEPTUAL DATABASE DESIGN



High level and abstract view of the reality

Independent from the DBMS that will be used



Entity-Relationship (E-R) Data Model

THE ENTITY-RELATIONSHIP (E-R) DATA MODEL



- **Entity** is an independent object or entity of the real world.
- **Relationship** is an association between more entities

- As well as each entity is the instance of an **entity type**, each relationship is an instance (**relationship instance**) of a certain **relationship type**.

- **WARNING:**

- RELATIONSHIPS in the ER model are DIFFERENT from RELATIONS in the relational model

THE ENTITY-RELATIONSHIP (E-R) DATA MODEL



ENTITY

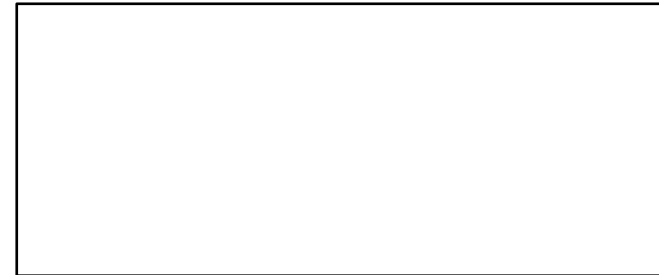

RELATIONSHIP

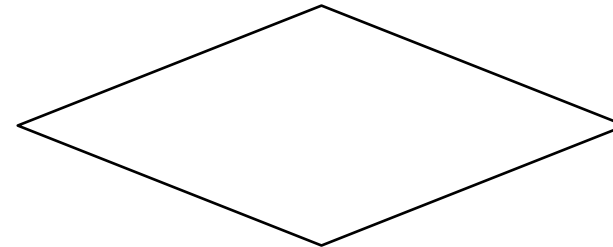

THE ENTITY-RELATIONSHIP (E-R) DATA MODEL



ATTRIBUTE

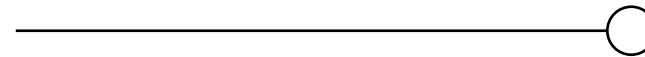

ATTRIBUTE
WITH
CARDINALITY

(m_A, M_A)

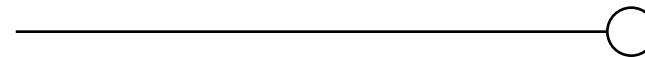

COMPOSITE
ATTRIBUTE

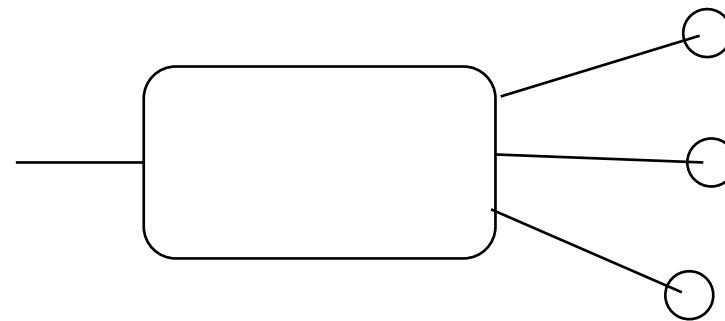

THE ENTITY-RELATIONSHIP (E-R) DATA MODEL

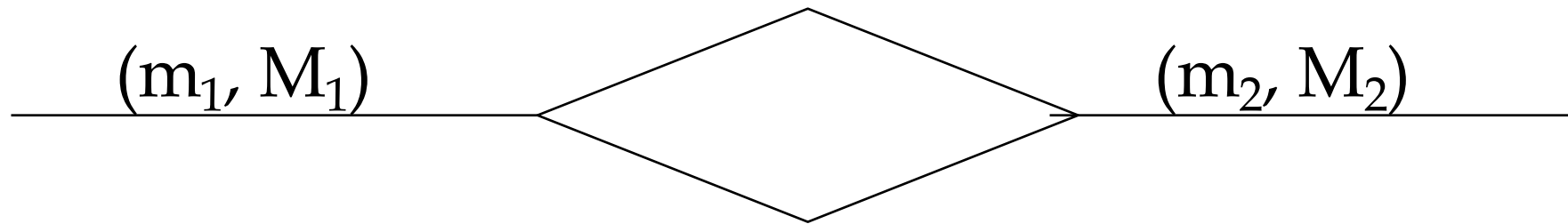

RELATIONSHIP
CARDINALITY

THE ENTITY-RELATIONSHIP (E-R) DATA MODEL



KEY
ATTRIBUTES

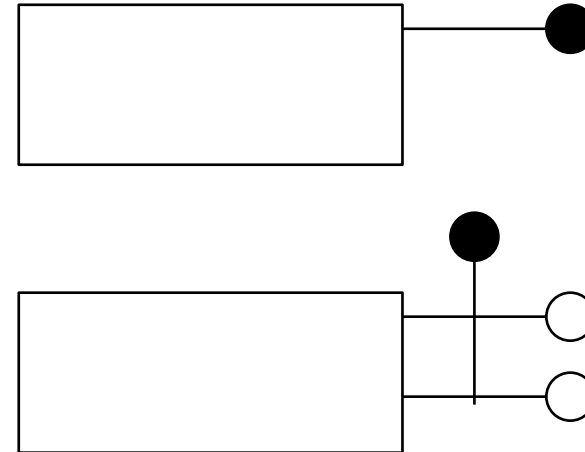

WEAK ENTITY
(with foreign key)

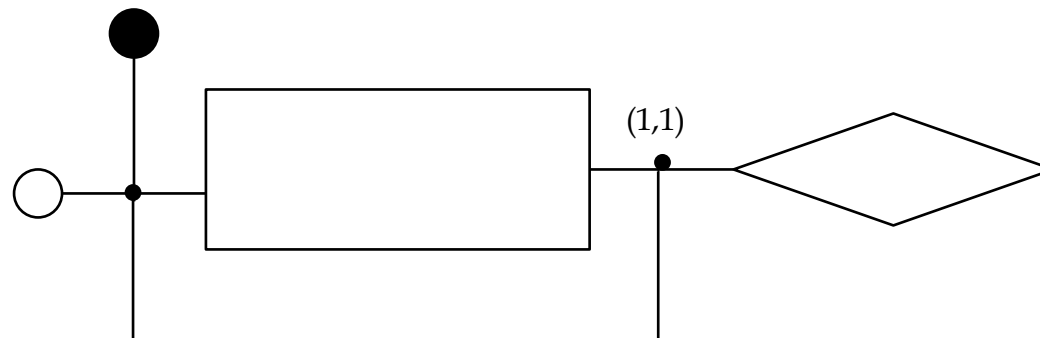

THE ENTITY-RELATIONSHIP (E-R) DATA MODEL

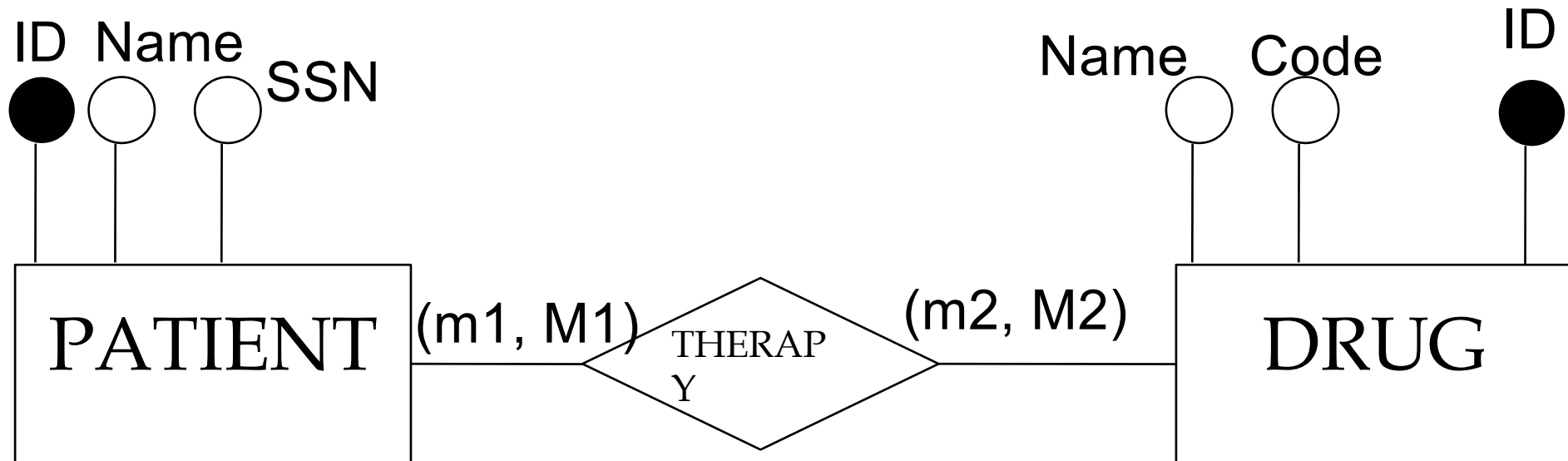

CARDINALITY



- Have to be specified for each entity participating in a relationship;
- They describe the minimum and maximum occurrences of each entity in a relationship
- They define how many times each entity can be involved with other entities through the specified relationship

CARDINALITY

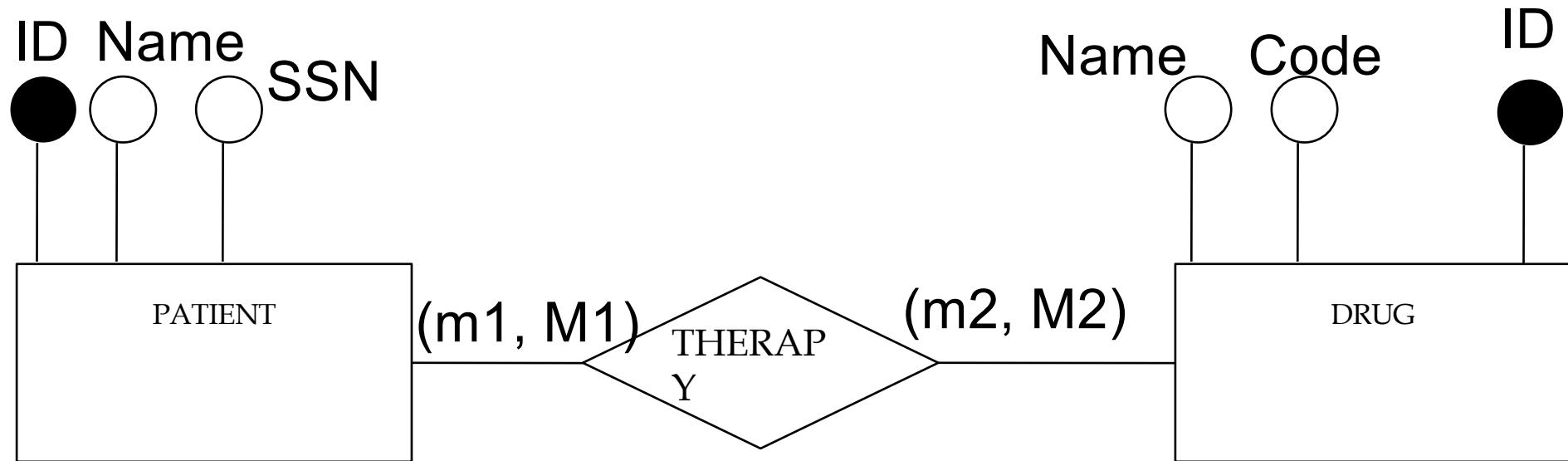

m1	M1	m2	M2	Cardinality
0	1	0	1	One-to-One
0	1	0	N	One-to-Many
0	N	0	N	Many-to-Many

CARDINALITY

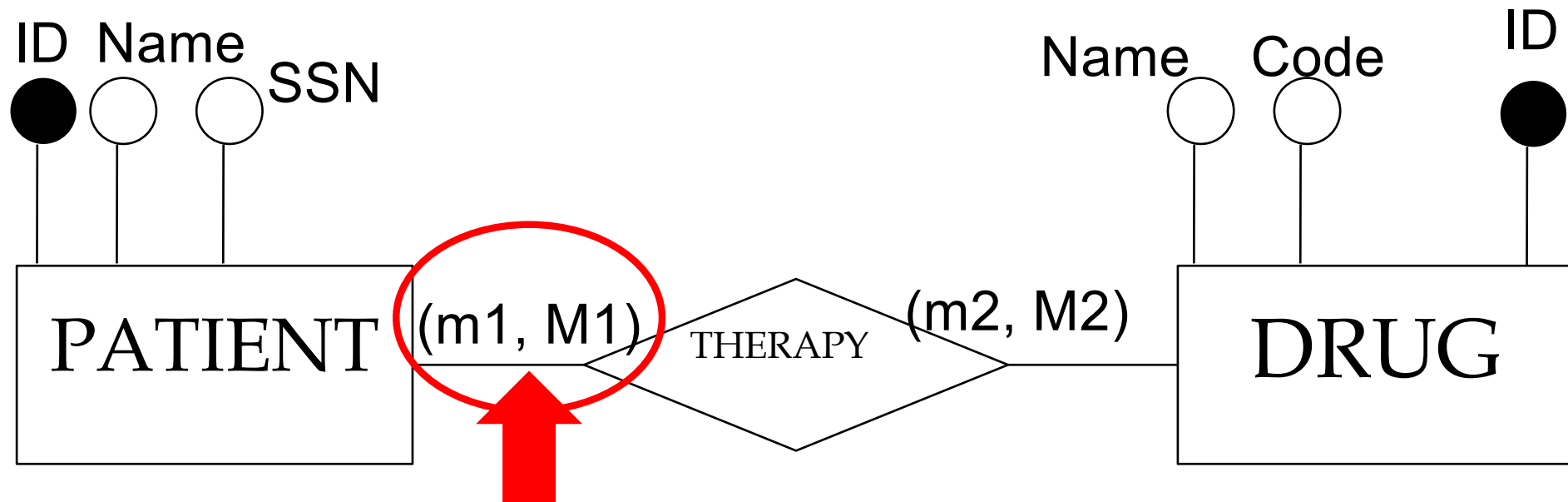

- If $M1 > m1 \geq 0 \rightarrow$ a patient has to (if $m1 > 0$) or can (if $m1 = 0$) participate to a minimum of **$m1$** occurrences and a maximum of **$M1$** occurrences of the **THERAPY** relationship.
- This implies that each patient has (or can have) at least $m1$ drugs assigned but no more than $M1$

CARDINALITY

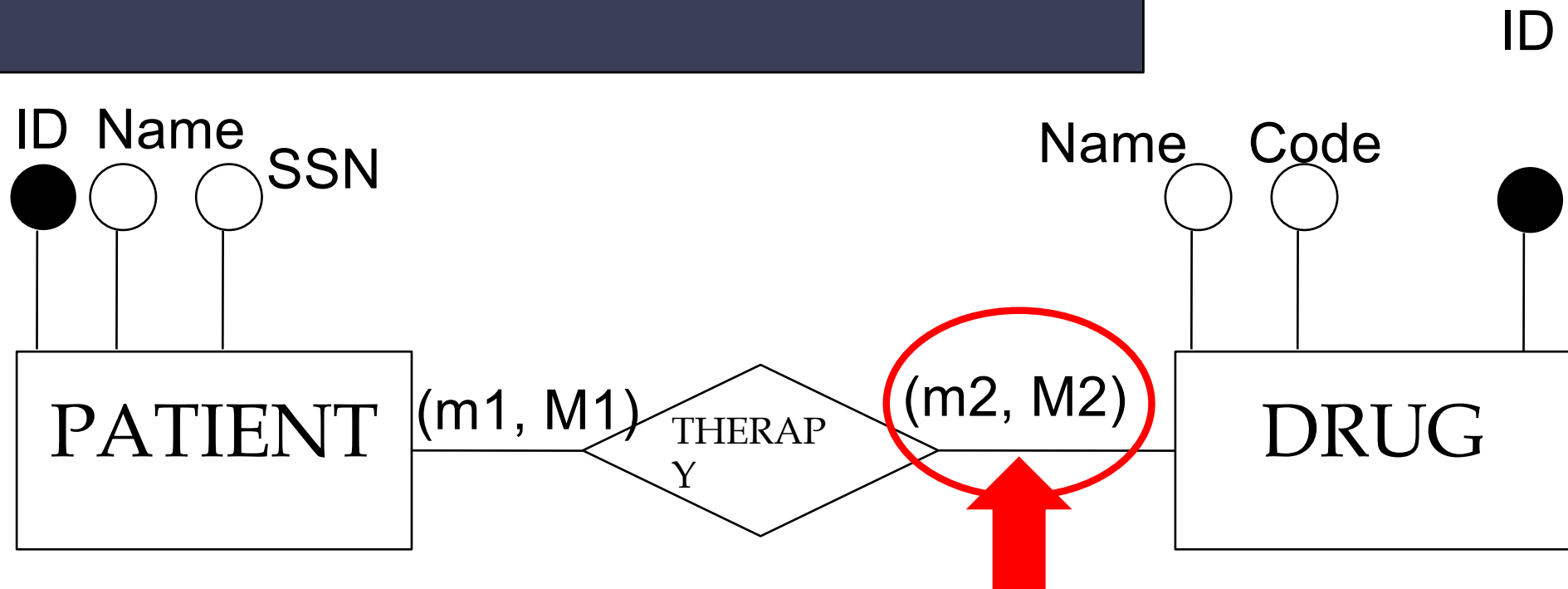

- If $M2 > m2 \geq 0 \rightarrow$ a drug has to (if $m2 > 0$) or can (if $m2 = 0$) participate to a minimum of $m2$ occurrences and a maximum of $M2$ occurrences of the THERAPY relationship.
- This implies that each drug has to (or can be) assigned to at least $m2$ patients but no more than $M2$.

Entity-Relationship (E-R) Data Model: example



The entity-relationship diagram describing a centralized databank for neuronal bioelectrical signals recorded during stereotactic neurosurgery

Entity-Relationship (E-R) Data Model

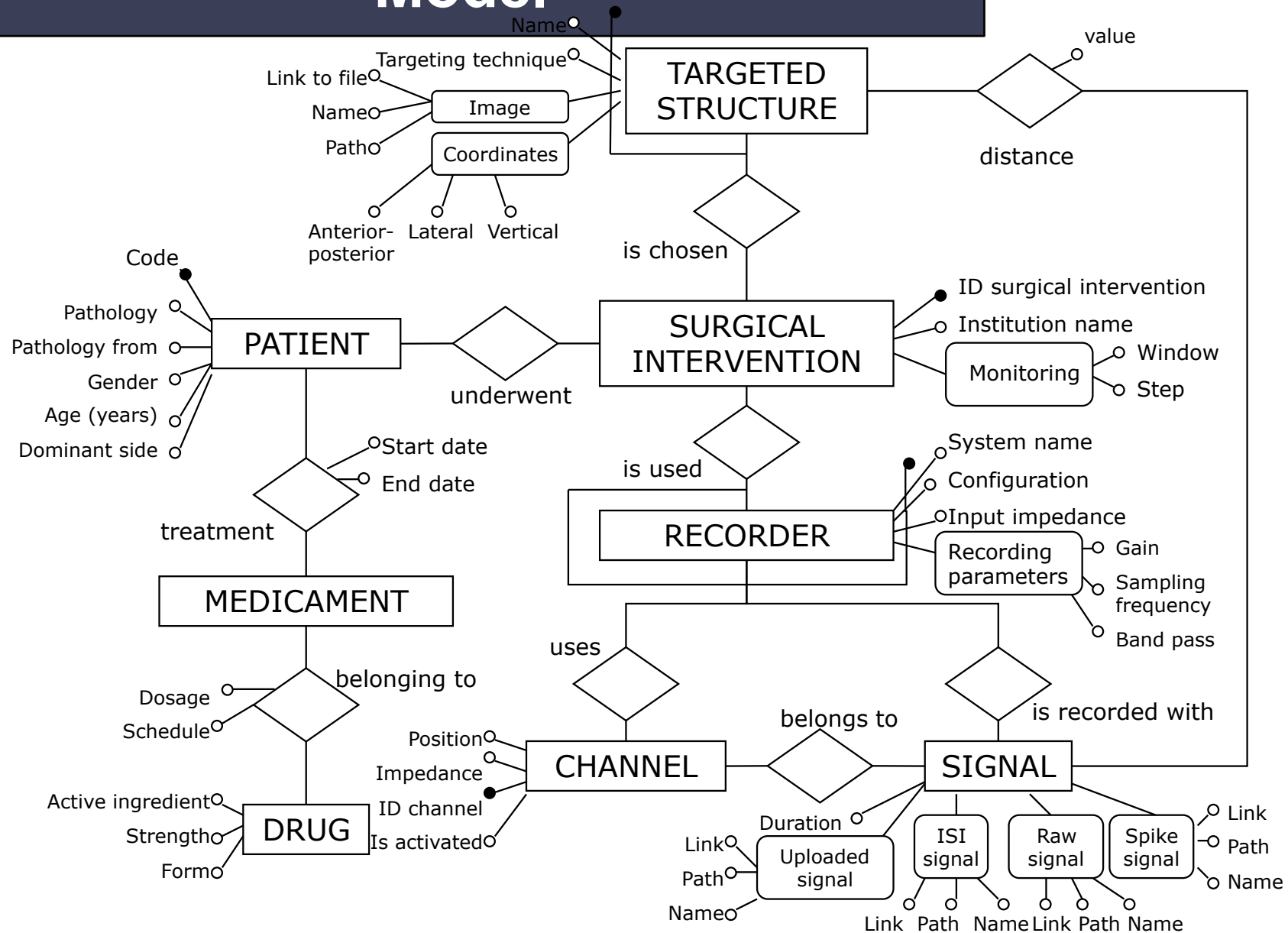

The NULL value: multiple meanings

1. Not valid for the current instance (Husband surname for a male)
2. Valid but not yet existing (Husband surname for a non-married woman)
3. Existing but it cannot be saved (patient's religion in some Countries cannot be stored to avoid discrimination)
4. Existing but unknown
5. Existing but not yet saved (patient's history not collected yet)
6. Stored and then deleted (erroneous information)
7. Available but in an updating phase (patient's therapy under modification)
8. Available but not reliable (a non final diagnosis)
9. Available but not valid (a blood parameter above the threshold of valid range)
10. Calculated from another NULL value (BMI if the weight is not present).

- Translates the abstract representation of the conceptual model in specifications that can be implemented through a DBMS
 - The result is the **logical schema**.
1. **Translation** from the conceptual schema to the logical schema using the DBMS data model;
 2. **Adaptation** of the logical schema to the characteristics of the specific DBMS
 3. Logical schema optimization → **Normalization**

STANDARD TRANSLATION

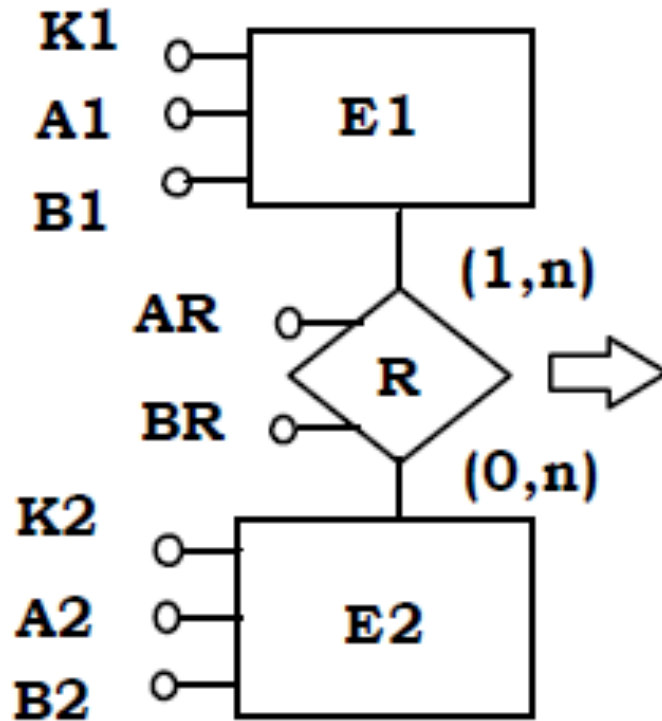

$E1 (\underline{K1}, A1, B1, \dots)$

$E2 (\underline{K2}, A2, B2, \dots)$

$R (\underline{K1, K2}, AR, BR, \dots)$