

Geometria di un satellite

- Sfera Celeste
- Sistemi di Coordinate
- Studio Eclissi
- Geometria Terra / Satellite

SMAD Chapter 5
p. 95

Sfera Celeste 1/2

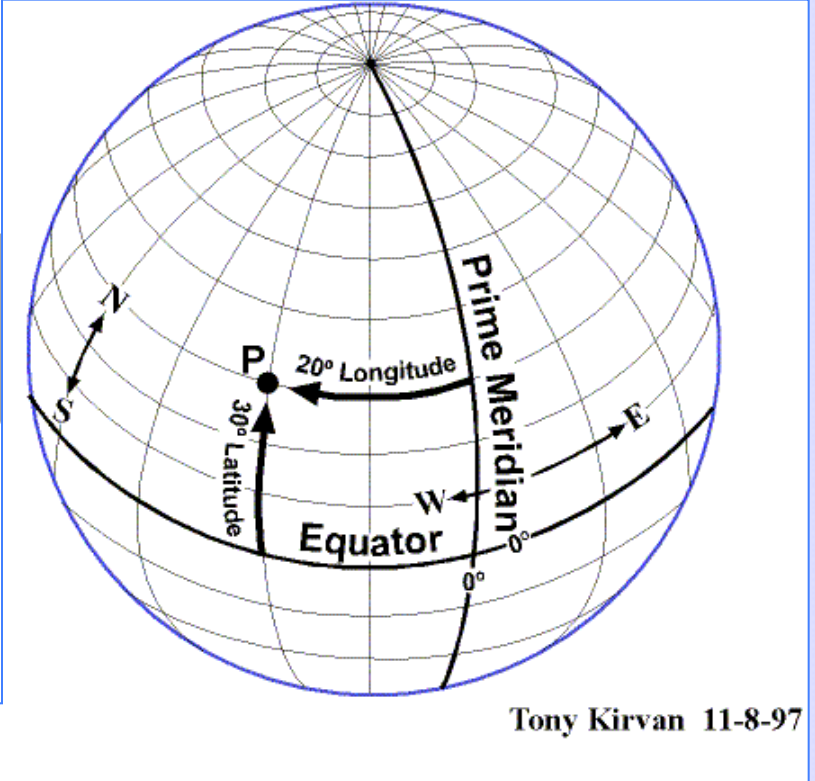
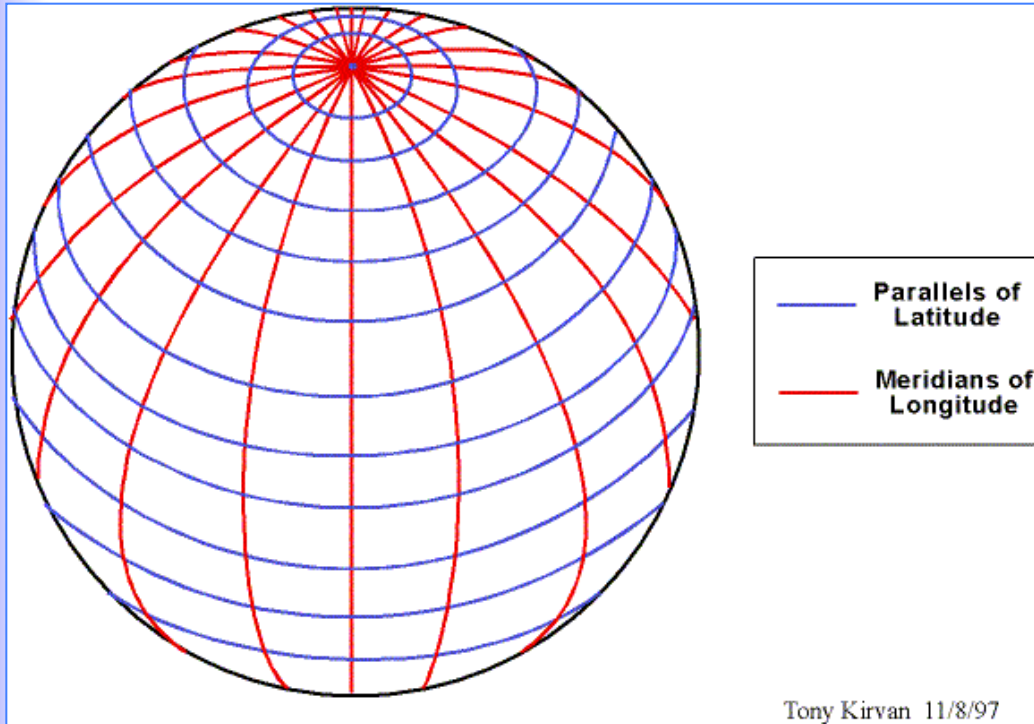

azimuth (longitudine ℓ)

elevazione (latitudine λ)

$$x = \cos \ell \cos \lambda$$

$$y = \sin \ell \cos \lambda$$

$$z = \sin \lambda$$

Sfera Celeste 2/2

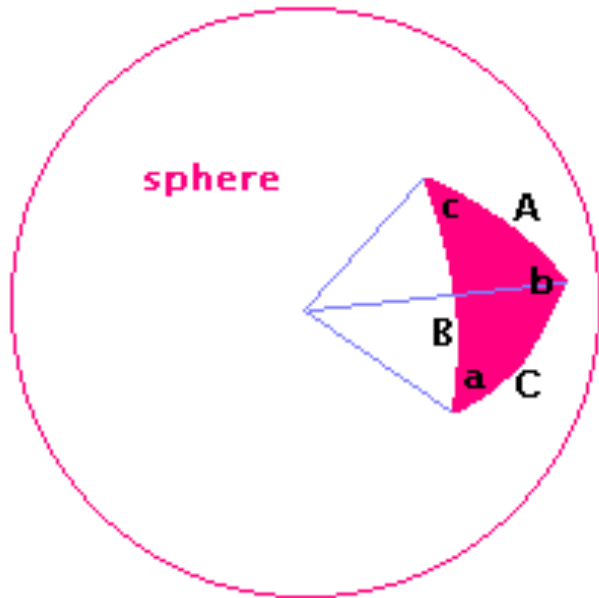

A spherical triangle consists of Great Circle Arcs, extending from the sphere's center, forming Great Circle Angles. Relations among arcs and angles are:

$$\cos(A) = \cos(B) \cos(C) + \sin(B) \sin(C) \cos(a)$$

$$\cos(a) = -\cos(b) \cos(c) + \sin(b) \sin(c) \cos(A)$$

$$\sin(A)/\sin(a) = \sin(B)/\sin(b) = \sin(C)/\sin(c)$$

SMAD Appendix D
Table D-3 p. 907

φ_1, φ_2 elevazione

θ_1, θ_2 azimuth

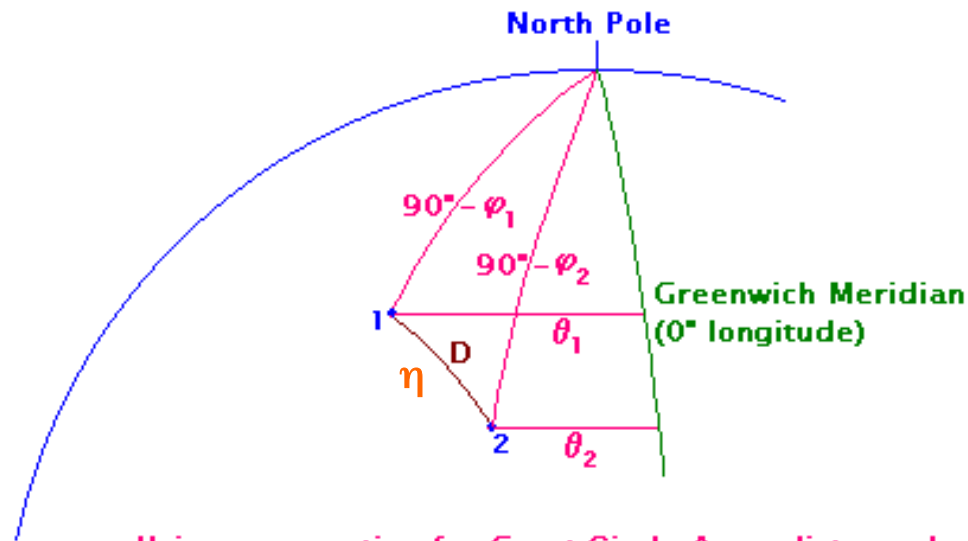

Using an equation for Great Circle Arcs, distance between 1 & 2 is estimated as:

$$\cos(\eta) = \cos(90^\circ - \varphi_1) \cos(90^\circ - \varphi_2) + \sin(90^\circ - \varphi_1) \sin(90^\circ - \varphi_2) \cos(\theta_1 - \theta_2)$$

$$D = 2\pi R_\oplus / (2\pi) \arccos(\sin(\varphi_1) \sin(\varphi_2) + \cos(\varphi_1) \cos(\varphi_2) \cos(\theta_1 - \theta_2))$$

Finestre di Lancio

P (30° W, 40° N)

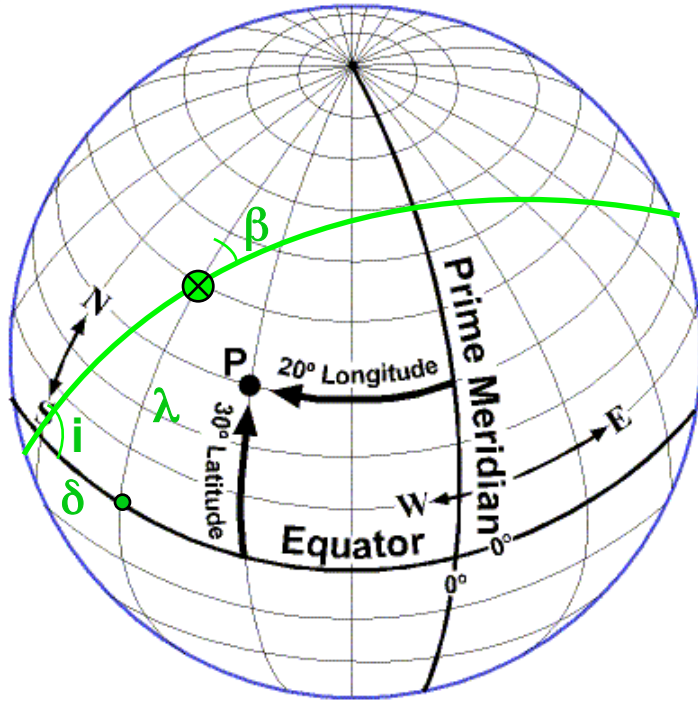

Tony Kirvan 11-8-97

SMAD Appendix D
Table D-1 p. 905 riga
4 col. 3

SMAD/Appendix D
Table D-1 p. 905 riga
5 col. 3

$$\lambda > i ?$$

$$\lambda = i ?$$

$$\lambda < i ?$$

$$\sin \beta = \cos i / \cos \lambda$$

$$\cos \delta = \cos \beta / \sin i$$

$$LST = \Omega + \delta$$

$$LST = \Omega + 180^\circ - \delta$$

SMAD chapter 6.4
p. 153-155

$$v_{sud} = -v_o \cos \gamma \cos \beta_L$$

$$v_{est} = v_o \cos \gamma \sin \beta_L - v_\lambda$$

$$v_r = v_o \sin \gamma \quad (v_z)$$

$$v_\lambda = 464.5 \cos \lambda \text{ m/s}$$

β azimuth di lancio
 γ angolo traiettoria
volo al *burn-out*
(vedi ultima trasparenza
su orbite)

Parametri Ellisse

$$v_t = v \cos \gamma (*)$$

$$v_r = v \sin \gamma$$

$\gamma=0$ per orbite
circolari ($v=v_t$, $v_r=0$)

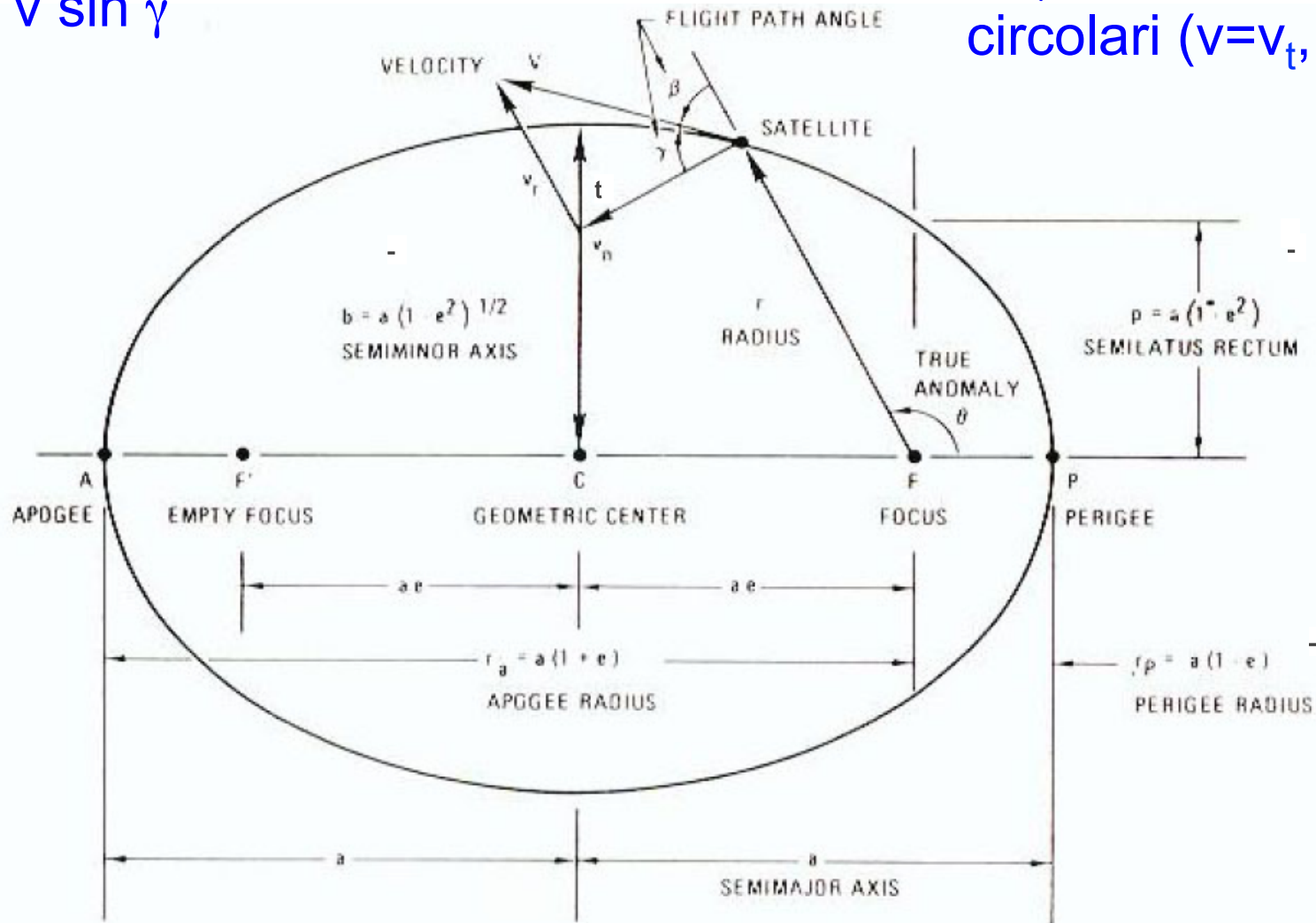

Sistemi di Coordinate 1/3

Sistema Geocentrico “Geografico”

λ - Geographic longitude

φ - Geographic latitude

R - Mean Radius of the Earth

O - The Geo-Center

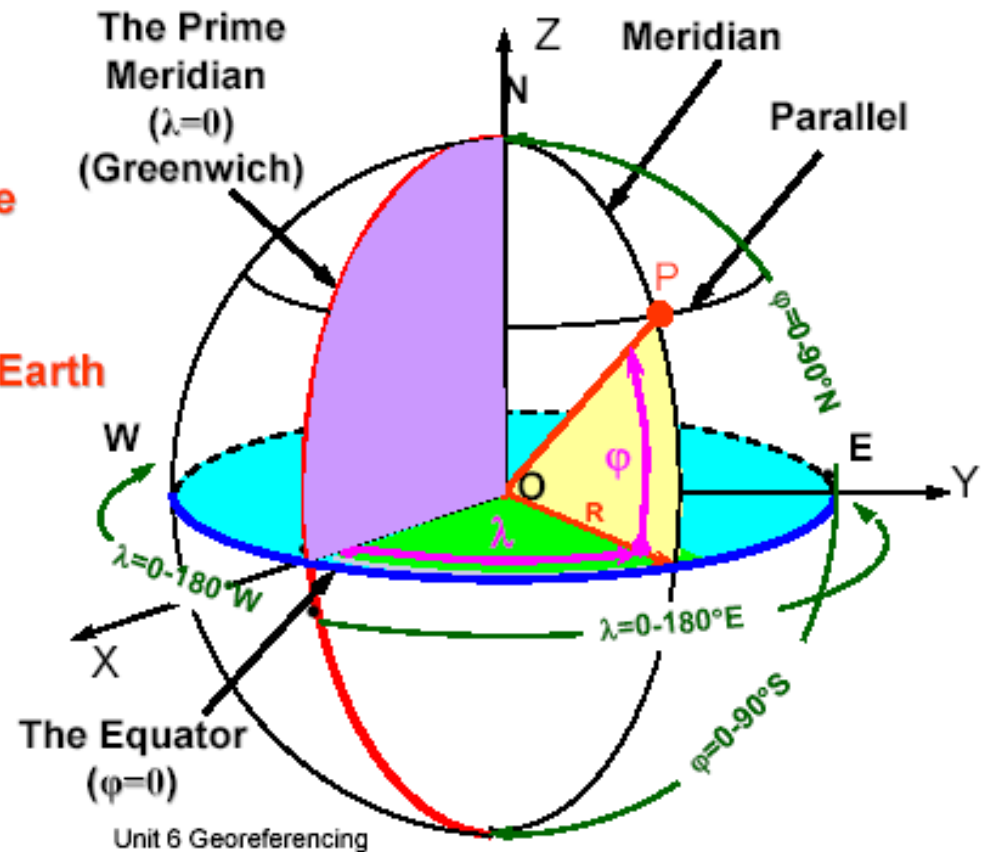

Attenzione all'indicazione lat/long !

Sistemi di Coordinate 2/3

Geocentric Inertial System

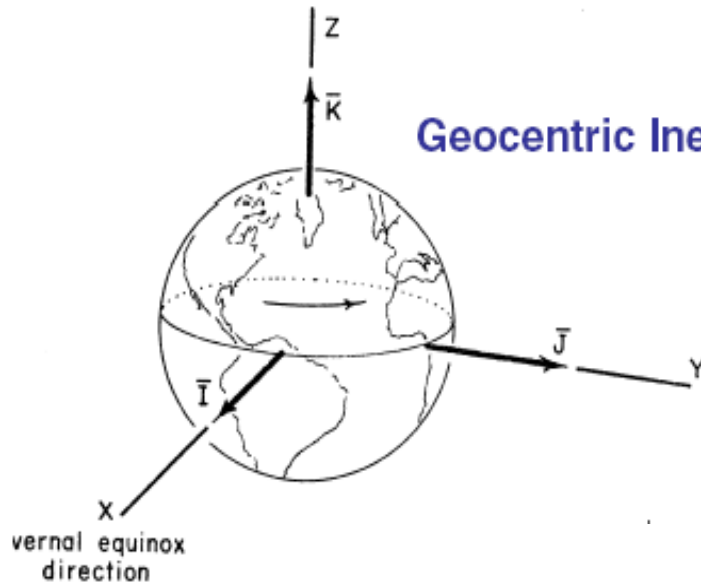

Heliocentric Inertial System

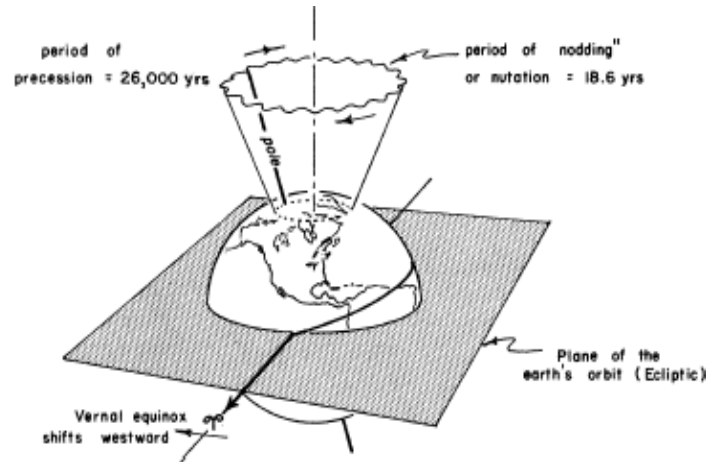
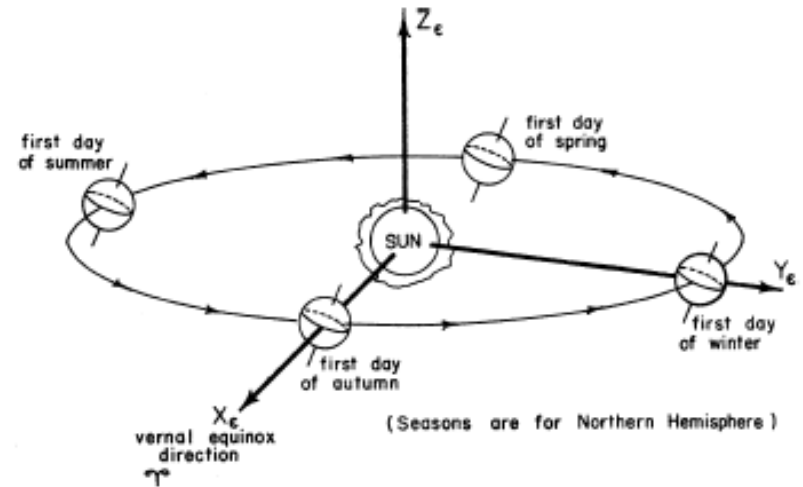

50.2786" westerly drift of the Vernal Equinox per year

azimuth = ascensione retta α

elevazione = declinazione δ

Sistemi di Coordinate 3/3

LVLH

Local Vertical – Local Horizontal

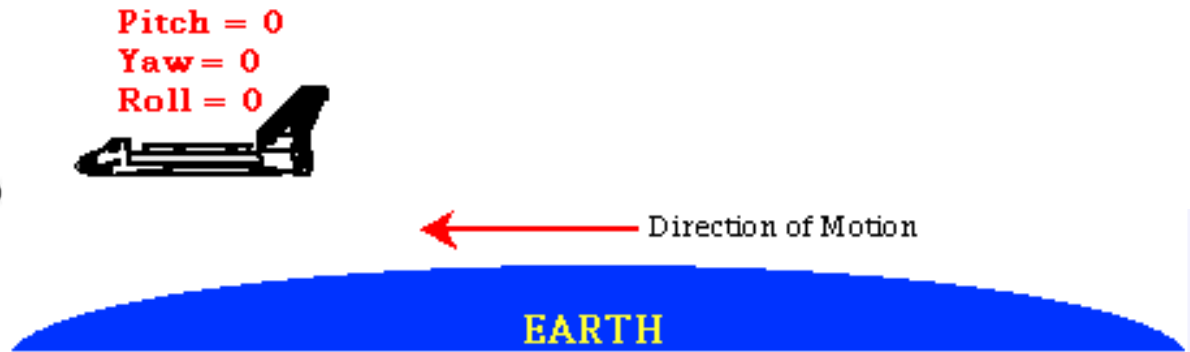
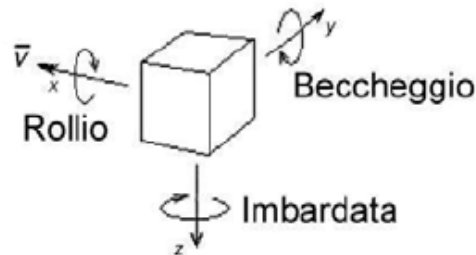
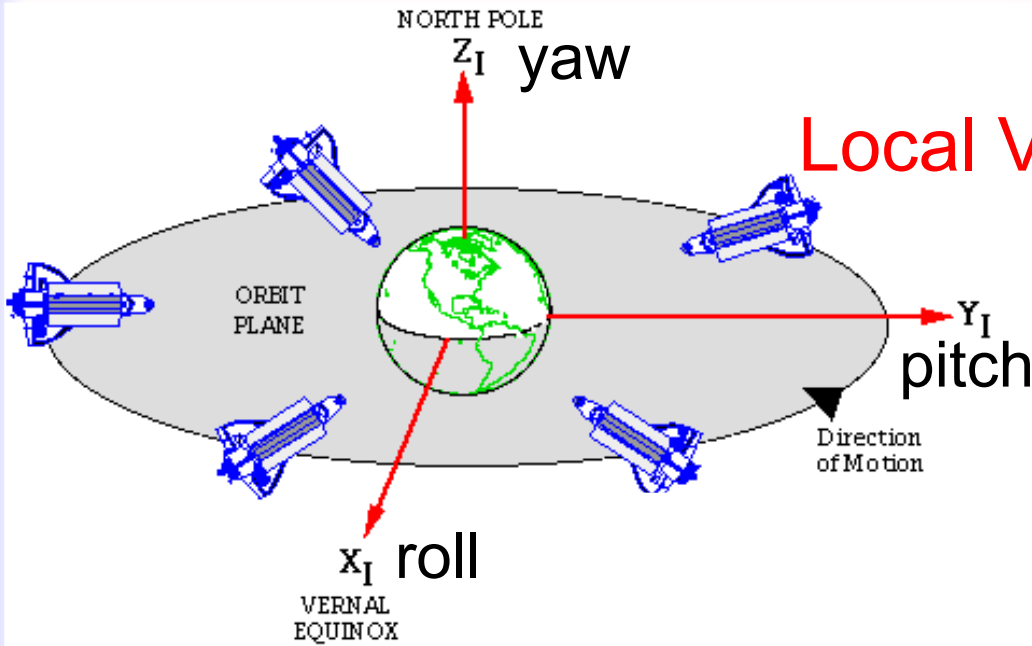

Terra

Sistemi di Coordinate 3/3

LVLH

Local Vertical – Local Horizontal

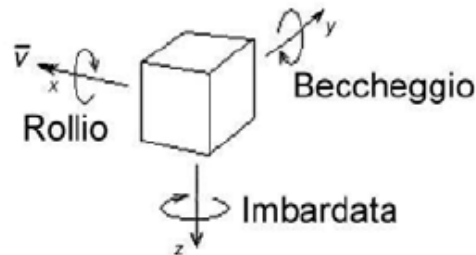
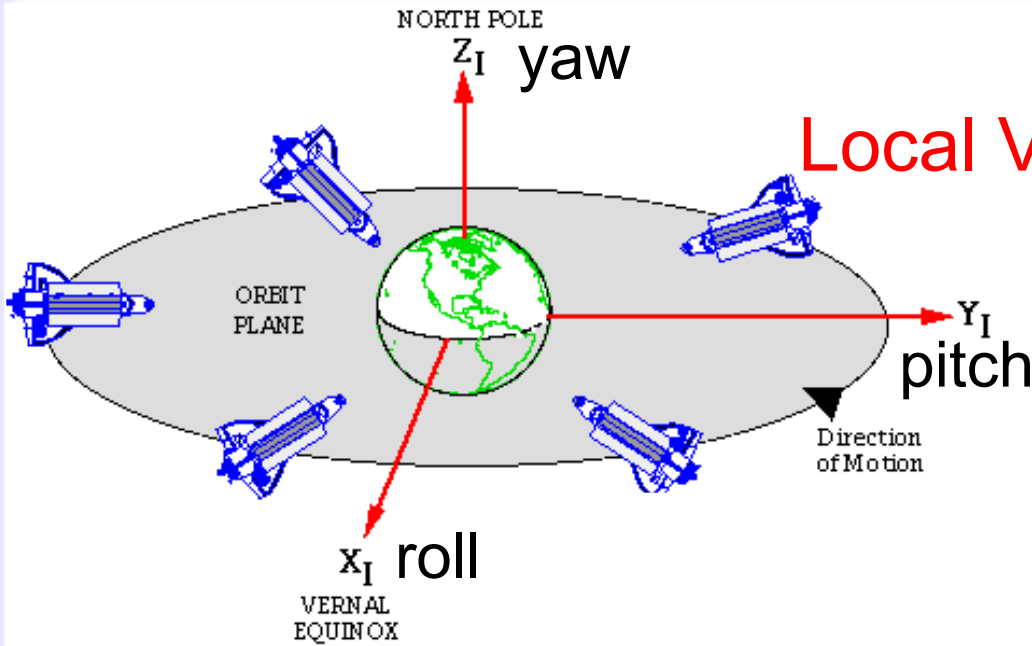

Pitch = 0
Yaw = 0
Roll = 0



Pitch = 90
Yaw = 0
Roll = 0



Pitch = 0
Yaw = 180
Roll = 0



Pitch = 0
Yaw = 0
Roll = -90



Direction of Motion



Terra

Studio Eclissi 1/3

$h = 1000 \text{ km}, i = 32^\circ$

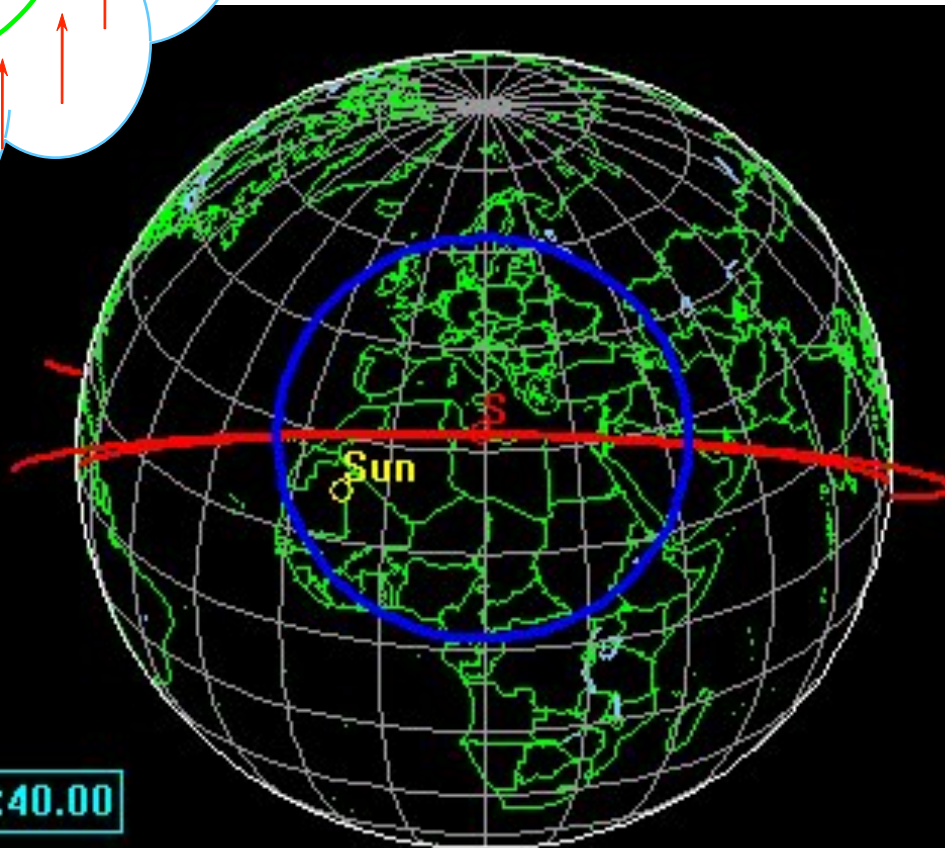
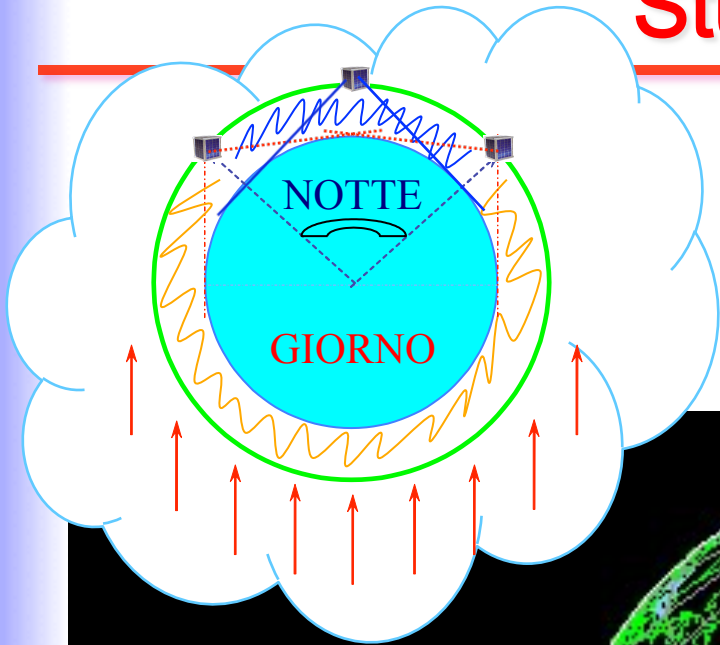

1 Jun 2004 12:26:40.00

Studio Eclissi 2/3

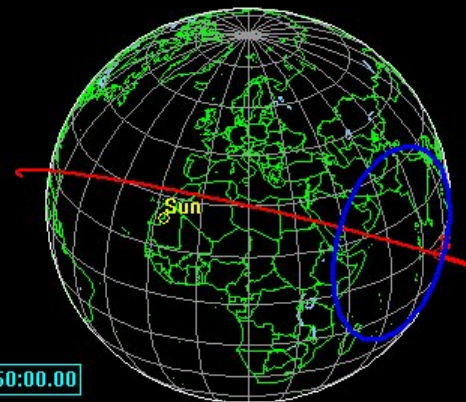
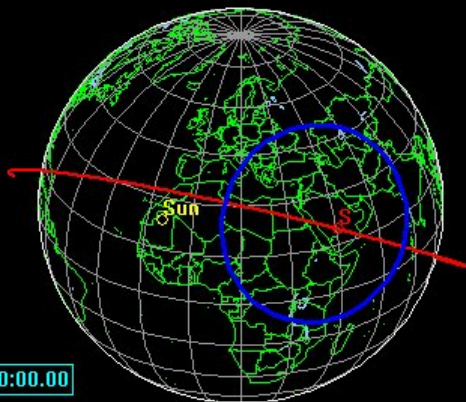
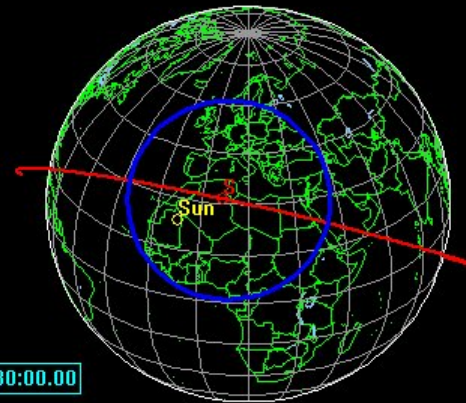
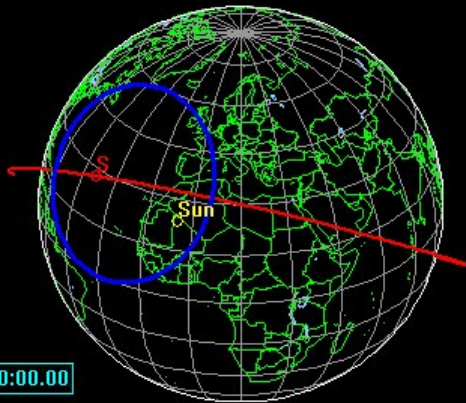
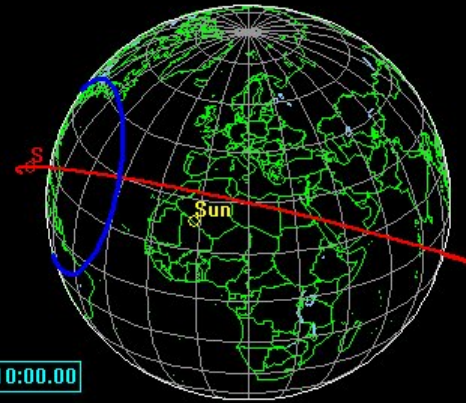
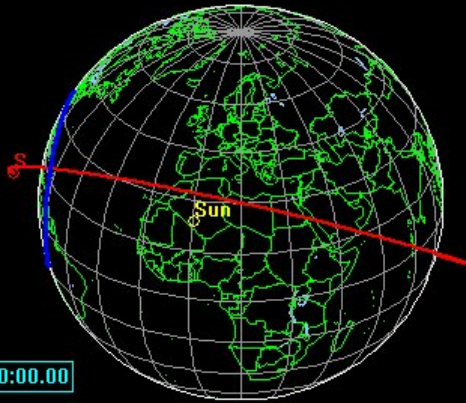

Studio Eclissi 3/3

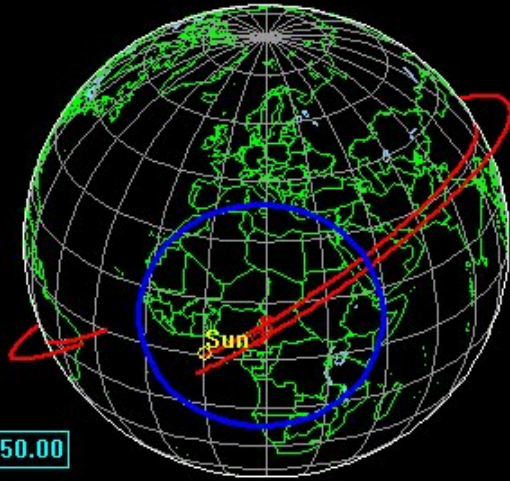

21 Mar 2004 12:04:50.00

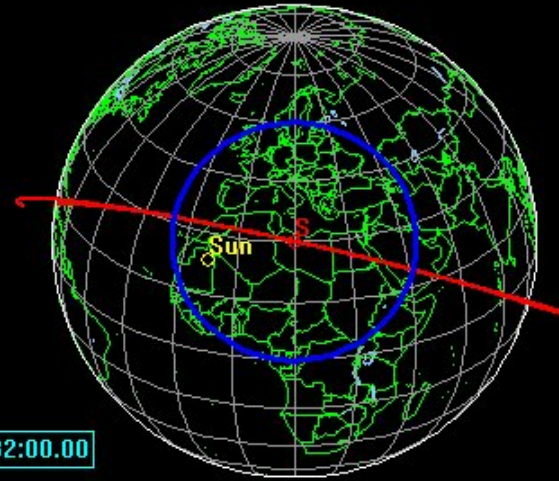

21 Jun 2004 12:32:00.00

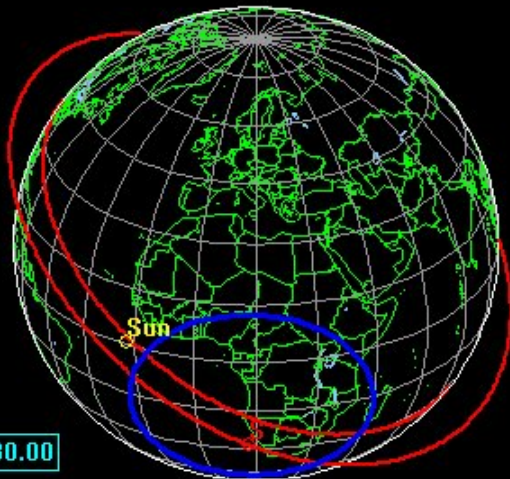

21 Sep 2004 13:02:30.00

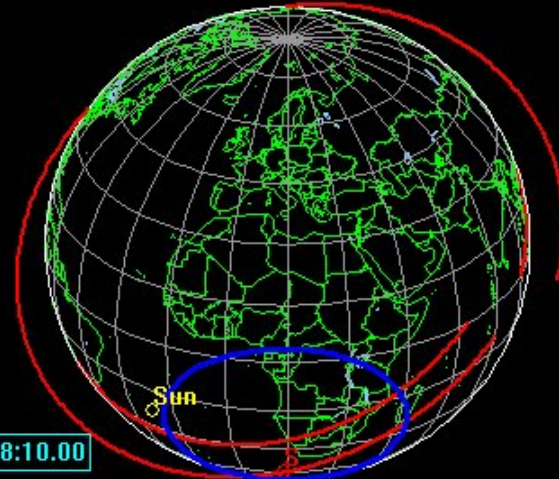

21 Dec 2004 13:28:10.00

SMAD chapter 5.1
Example 1, 2 e 3
p. 105-110

Geometria di un satellite 2/3

“isometric view”

“S/C centered celestial sphere” (inerziale)

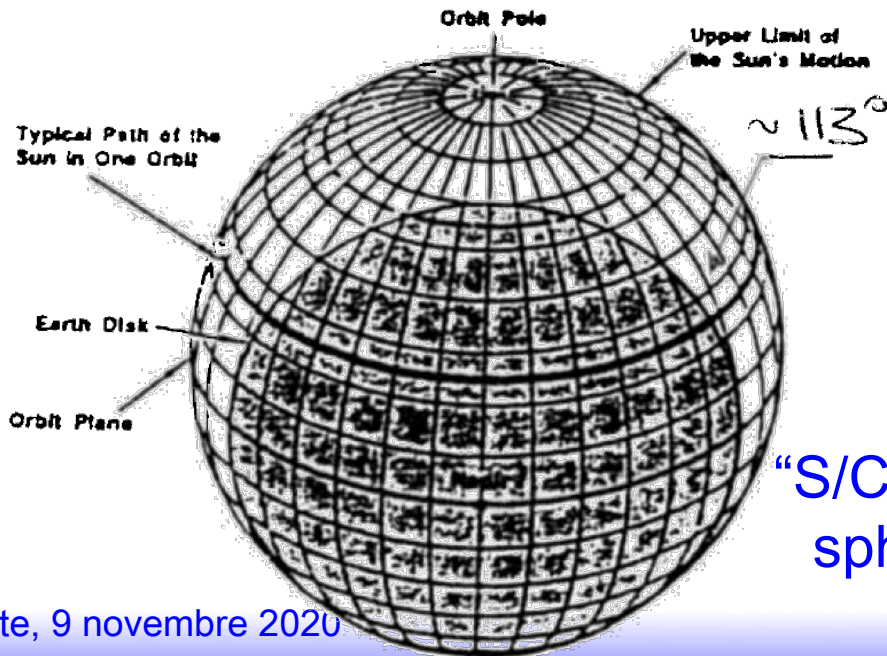
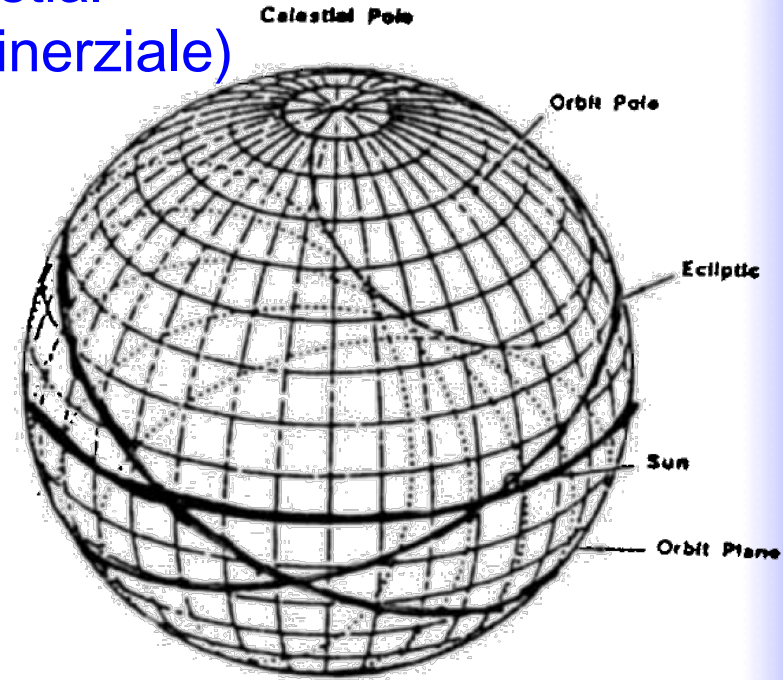
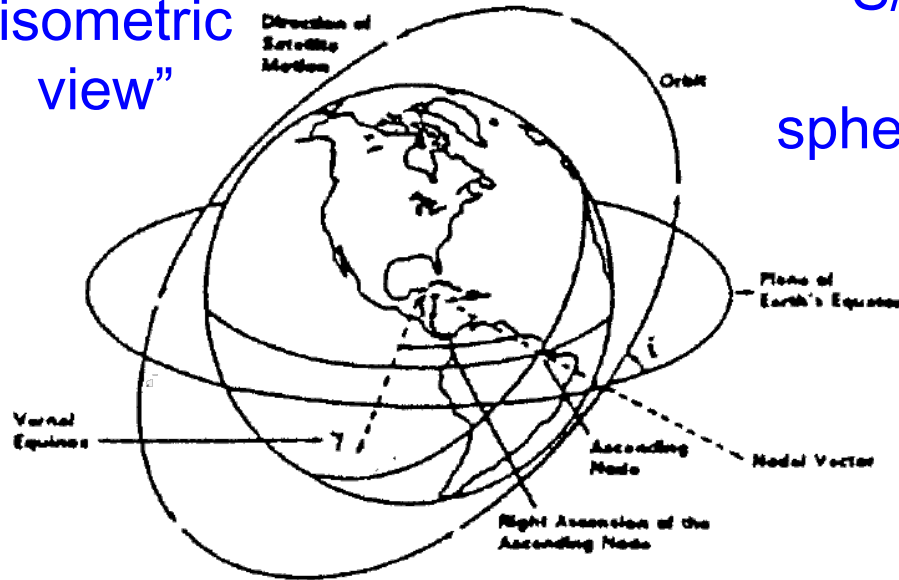

$$h = 1000 \text{ km}, i = 32^\circ \Rightarrow$$

$$\tau = 105 \text{ min}, \rho = 60^\circ$$

“S/C centered celestial sphere” (riferimento terrestre)

Geometria di un satellite 3/3

“S/C centered celestial sphere”

$$\cos \Phi/2 = \cos \rho / \cos \beta_s$$

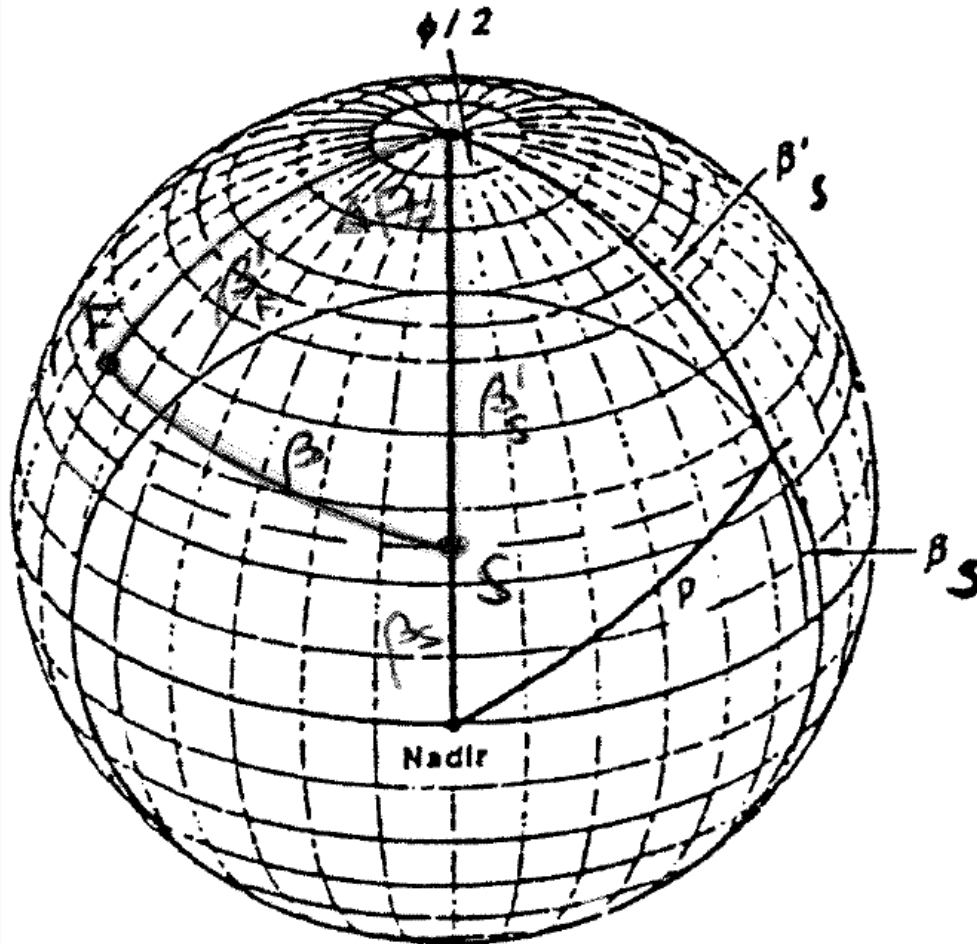

$$\beta_s = 25^\circ \Rightarrow \Phi/2 = 56.5^\circ$$

Durata fase notturna (eclisse):
max e min

β_s : max e min β

$$\beta_F = 35^\circ, Az_0 = 70^\circ$$

$$A = 0.5 \text{ m}^2 \Rightarrow$$

- “eclisse”: $Az = Az_0 \pm \Phi/2$

- “dietro”: $\beta = \pm \pi/2$

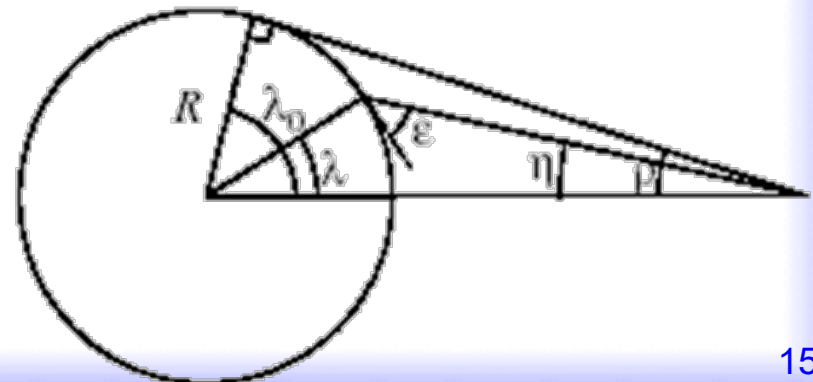

Analisi dell'eclissi da una LEO

Passaggio sopra la stazione 1/5

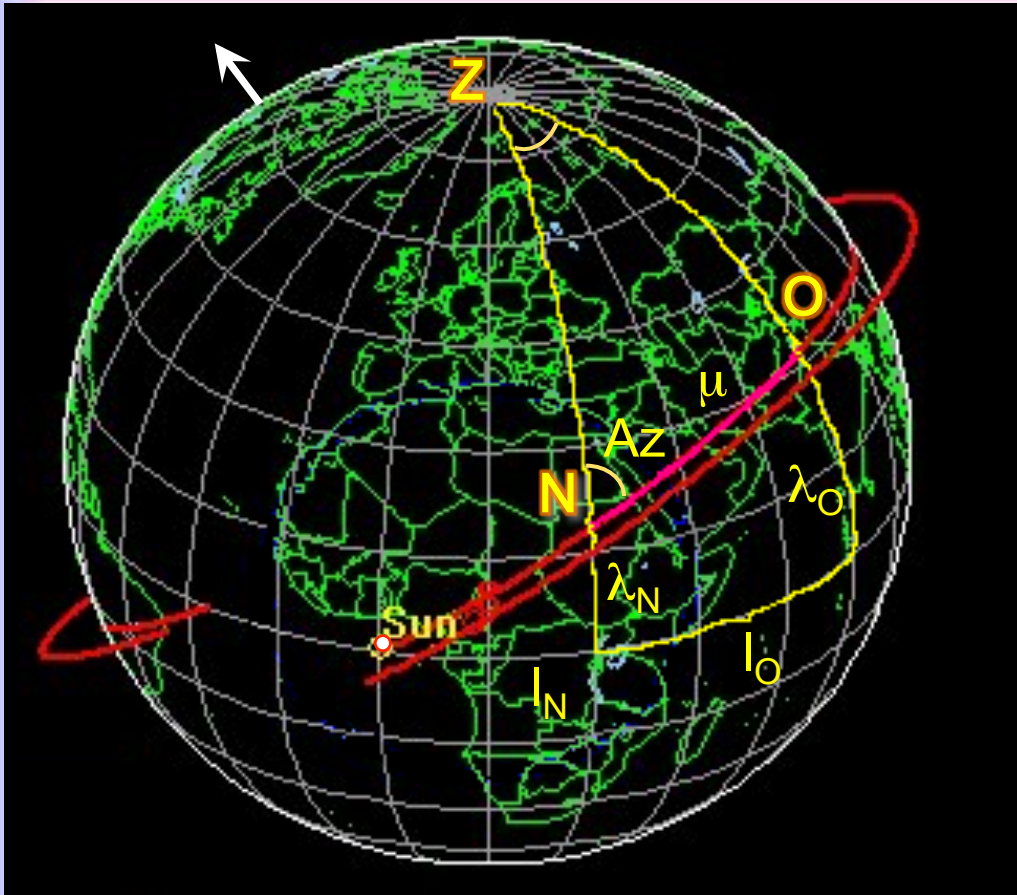

“Earth centered celestial sphere”

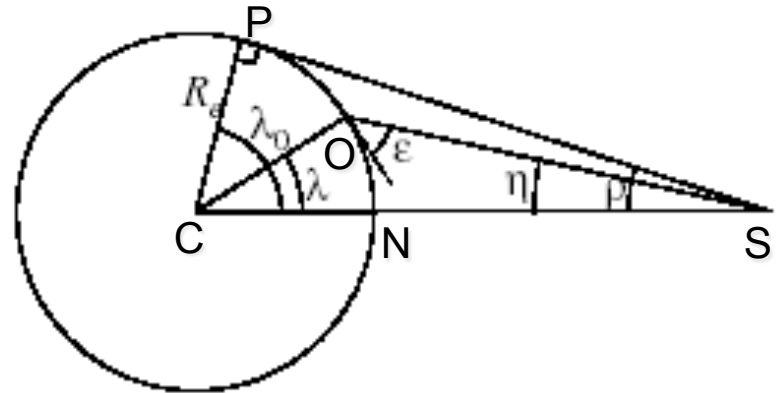

Meglio: geometria vista dal satellite!

Nota: quella segnata non è un' orbita del satellite ma un cerchio max che passa per O e N

N = Sub Satellite Point (l_N, λ_N)

O = Punto qls Terra (l_O, λ_O) !!!

$$\cos \mu = \sin \lambda_N \sin \lambda_O + \cos \lambda_N \cos \lambda_O \cos(l_O - l_N) \Rightarrow \eta$$

$$\sin \lambda_O = \sin \lambda_N \cos \mu + \cos \lambda_N \sin \mu \cos Az \quad (\mu \equiv \lambda)$$

$$\cos Az = (\sin \lambda_O - \sin \lambda_N \cos \mu) / \cos \lambda_N \sin \mu$$

SMAD chapter 5.2
fig 5-12 p. 112

Risultato: angoli da satellite

Passaggio sopra la stazione 2/5

“Earth centered celestial sphere”

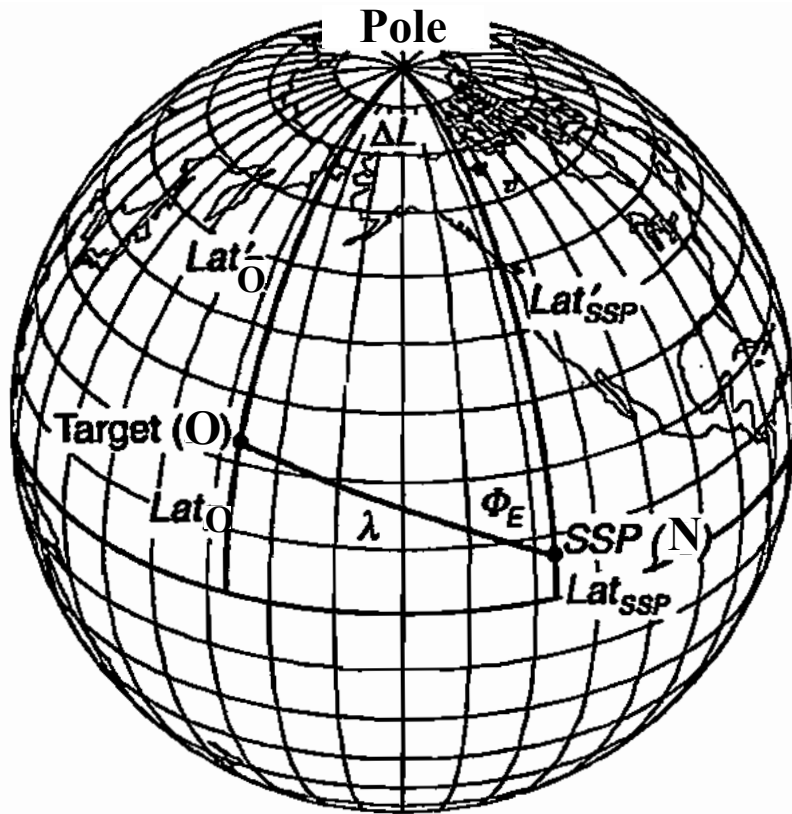

$$l_o = 200^\circ, \lambda_o = 22^\circ \text{ (hawaii)}$$

$$l_N = 185^\circ, \lambda_N = 10^\circ$$

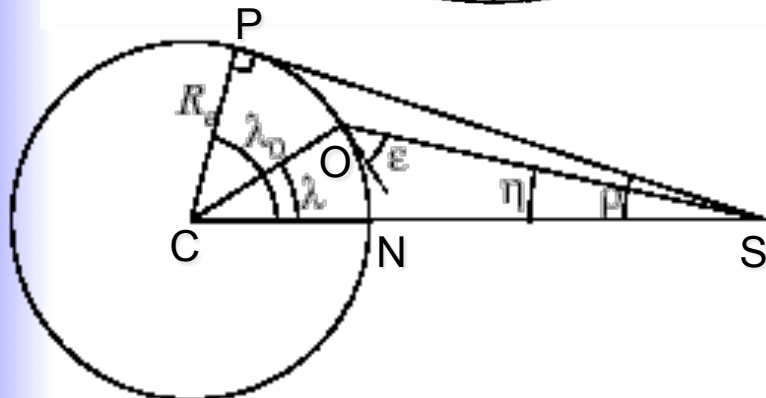

Passaggio sopra la stazione 5/5

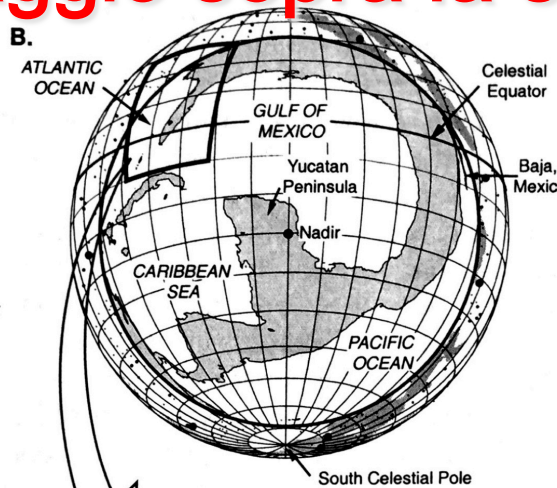
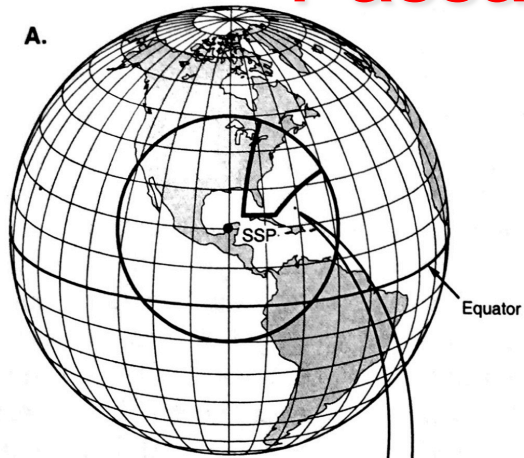

© Microcosm, Inc. 1998

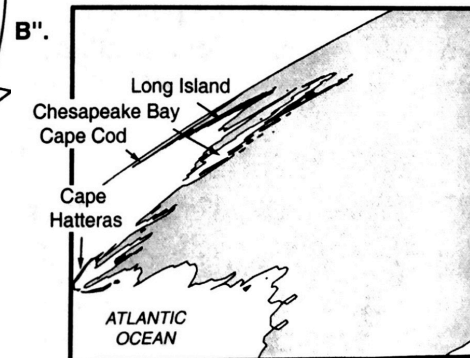
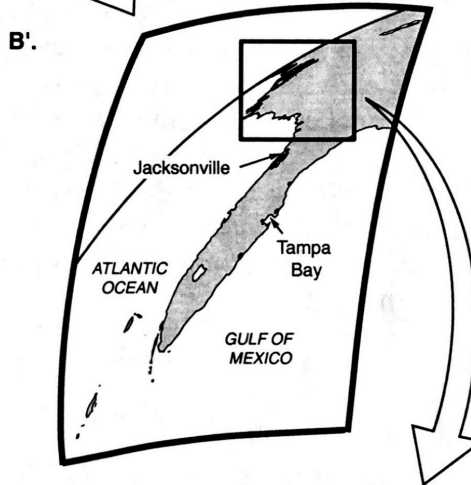
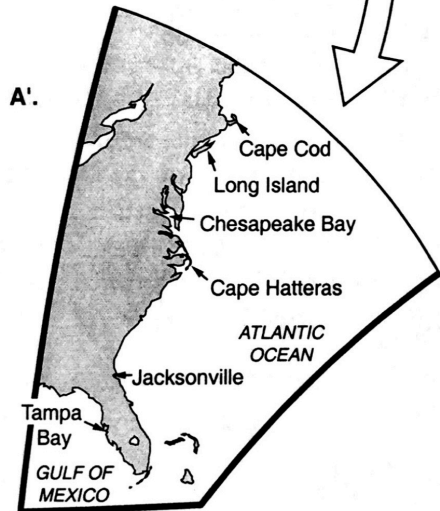

A. Geometry on the Earth's Surface
(SSP=Subsatellite Point)

B. Geometry Seen on the Spacecraft Centered
Celestial Sphere

A'. Region on the Earth Seen by the 35 mm
Camera Frame Shown in (B')

B'. Field of View of a 35 mm Camera with a
Normal Lens Looking Along the East Coast of
the US.

B''. Enlargement of the 35 mm Frame Showing
the Region from Georgia to Massachusetts.

Passaggio sopra la stazione 5/5

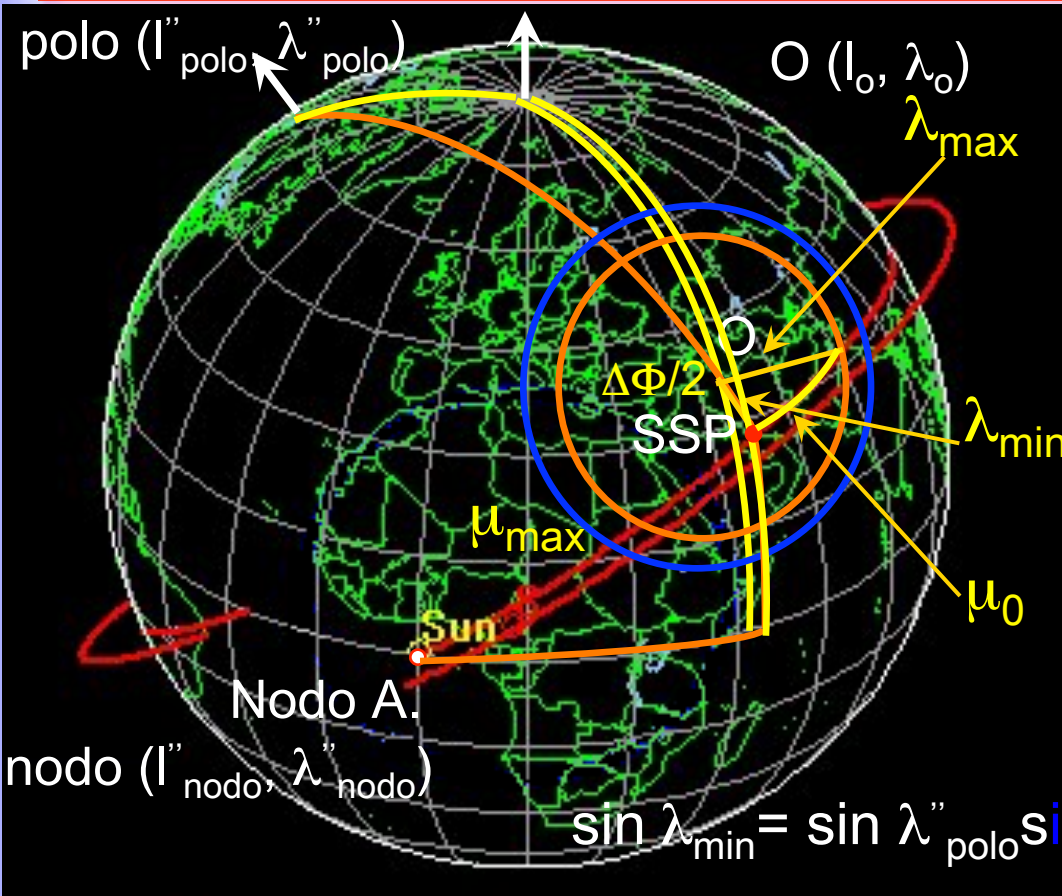

$$\sin \eta_{\max} = \cos \varepsilon_{\min} \sin \rho$$

$$\lambda_{\max} = \pi/2 - \eta_{\max} - \varepsilon_{\min}$$

“Earth centered celestial sphere”

$$D_{\max} = R_T \sin \lambda_{\max} / \sin \eta_{\max}$$

$$\lambda''_{\text{polo}} = \pi/2 - i \quad (\text{lat})$$

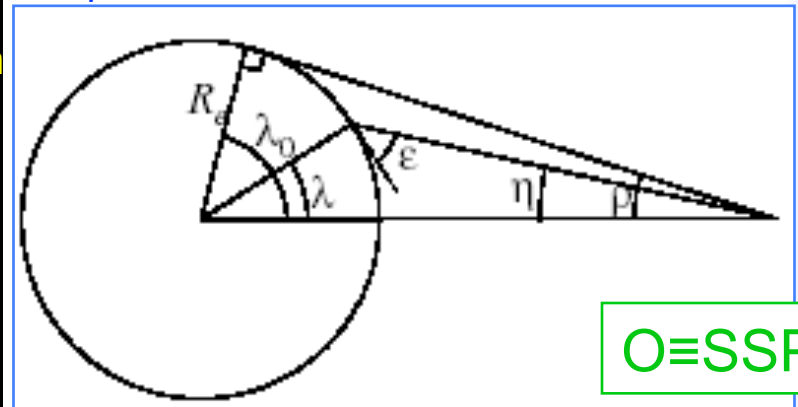

$$\sin \lambda_{\min} = \sin \lambda''_{\text{polo}} \sin \lambda_0 + \cos \lambda''_{\text{polo}} \cos \lambda_0 \cos(l_o - l''_{\text{polo}})$$

$$\tan \eta_{\min} = \sin \rho \sin \lambda_{\min} / (1 - \sin \rho \cos \lambda_{\min})$$

$$\varepsilon_{\max} = \pi/2 - \eta_{\min} - \lambda_{\min}$$

$$R_T \sin \lambda_{\min} = D_{\min} \sin \eta_{\min}$$

$$\omega_{\max} = \dot{\theta}_{\max} = v_{\text{sat}} / D_{\min}$$

$$\cos \Delta\Phi/2 = \tan \lambda_{\min} / \tan \lambda_{\max}$$

SMAD chapter 5.3.1
fig 5-17 p. 118-121

$$T = \tau/180^\circ \operatorname{acos}(\cos \lambda_{\max} / \cos \lambda_{\min})$$

Passaggio sopra la stazione 2/2

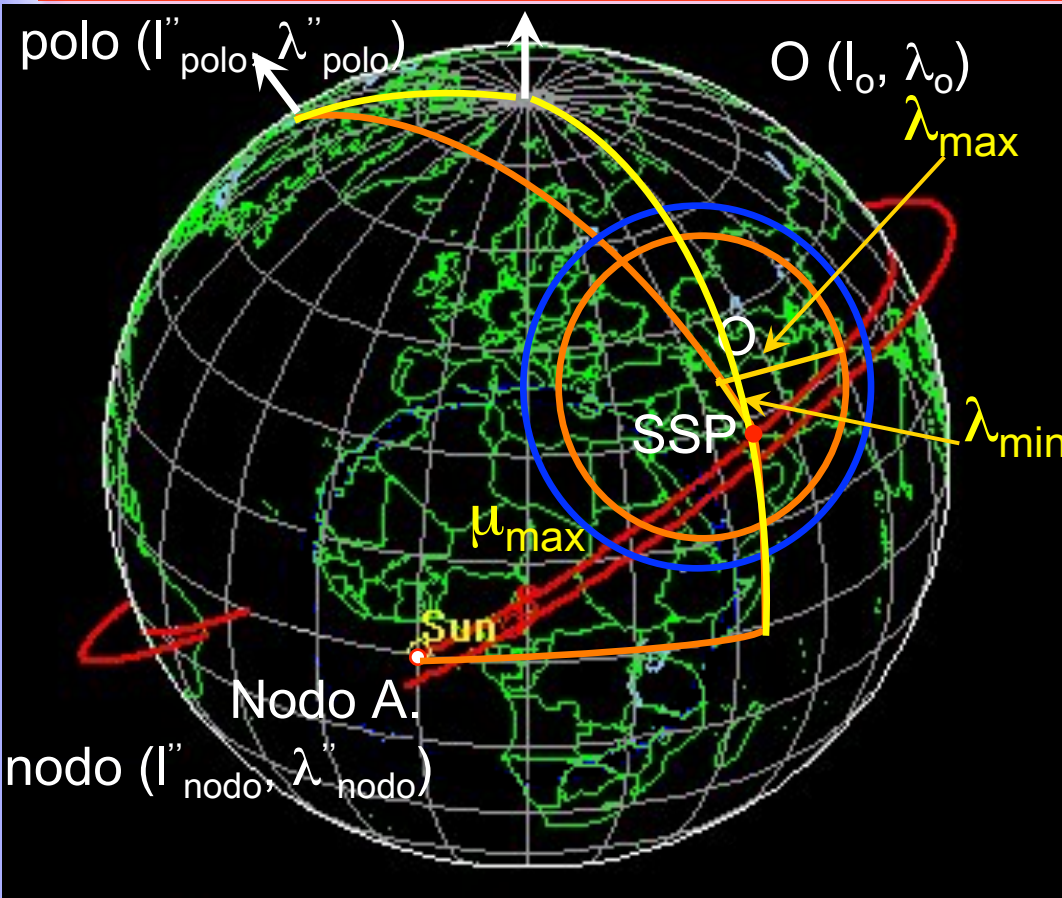

$$\sin \eta_{\max} = \cos \varepsilon_{\min} \sin \rho$$

$$\lambda_{\max} = \pi/2 - \eta_{\max} - \varepsilon_{\min}$$

$$D_{\max} = R_T \sin \lambda_{\max} / \sin \eta_{\max}$$

$$\lambda''_{\text{polo}} = \pi/2 - i \quad (\text{lat})$$

$$l''_{\text{polo}} = l''_{\text{nodo}} - \pi/2 \quad (\text{long})$$

$$\sin(l_o - l''_{\text{nodo}}) = \tan \lambda_o / \tan i$$

$$\sin \mu_{\max} = \sin \lambda_o / \sin i \quad \text{O} \equiv \text{SSP}$$

SMAD Appendix D
Table D-1 p. 905
riga 7 col. 1

SMAD Appendix D
Table D-1 p. 905
riga 7 col. 2

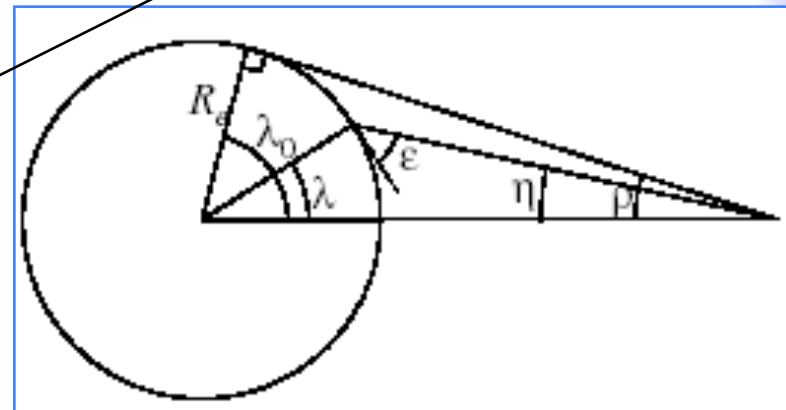

Geometria Terra / Satellite

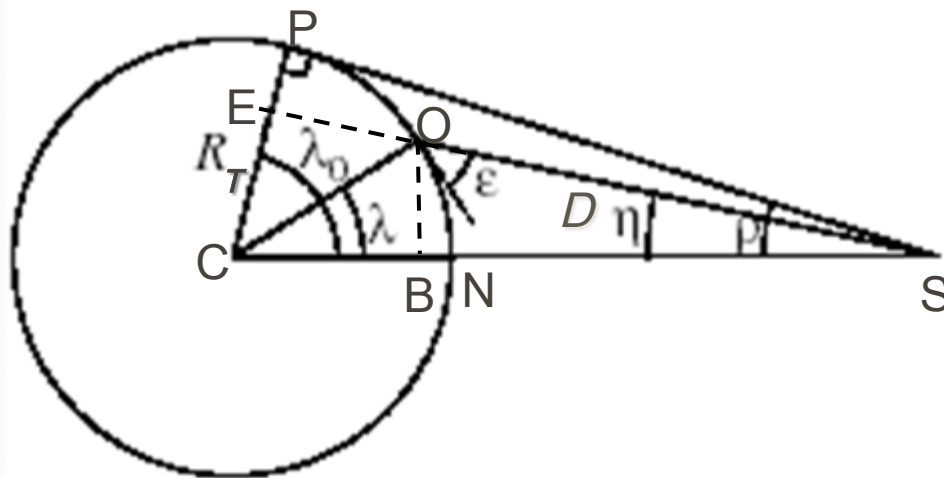

ρ raggio angolare Terra

η angolo di nadir

ε elevazione

λ angolo centrale Terra
(swath width)

SMAD chapter 5.2
fig 5-13 p. 110-113

$$\sin \rho = \cos \lambda_0 = R_T / R = R_T / (R_T + h)$$

$$\sin \eta = \cos \varepsilon \sin \rho$$

$$\lambda = \pi/2 - \eta - \varepsilon$$

$$\text{tg } \eta = \sin \rho \sin \lambda / (1 - \sin \rho \cos \lambda)$$

$$D = R_T \sin \lambda / \sin \eta$$

