

Il sistema di controllo di assetto di un satellite

SOTTO-SISTEMI

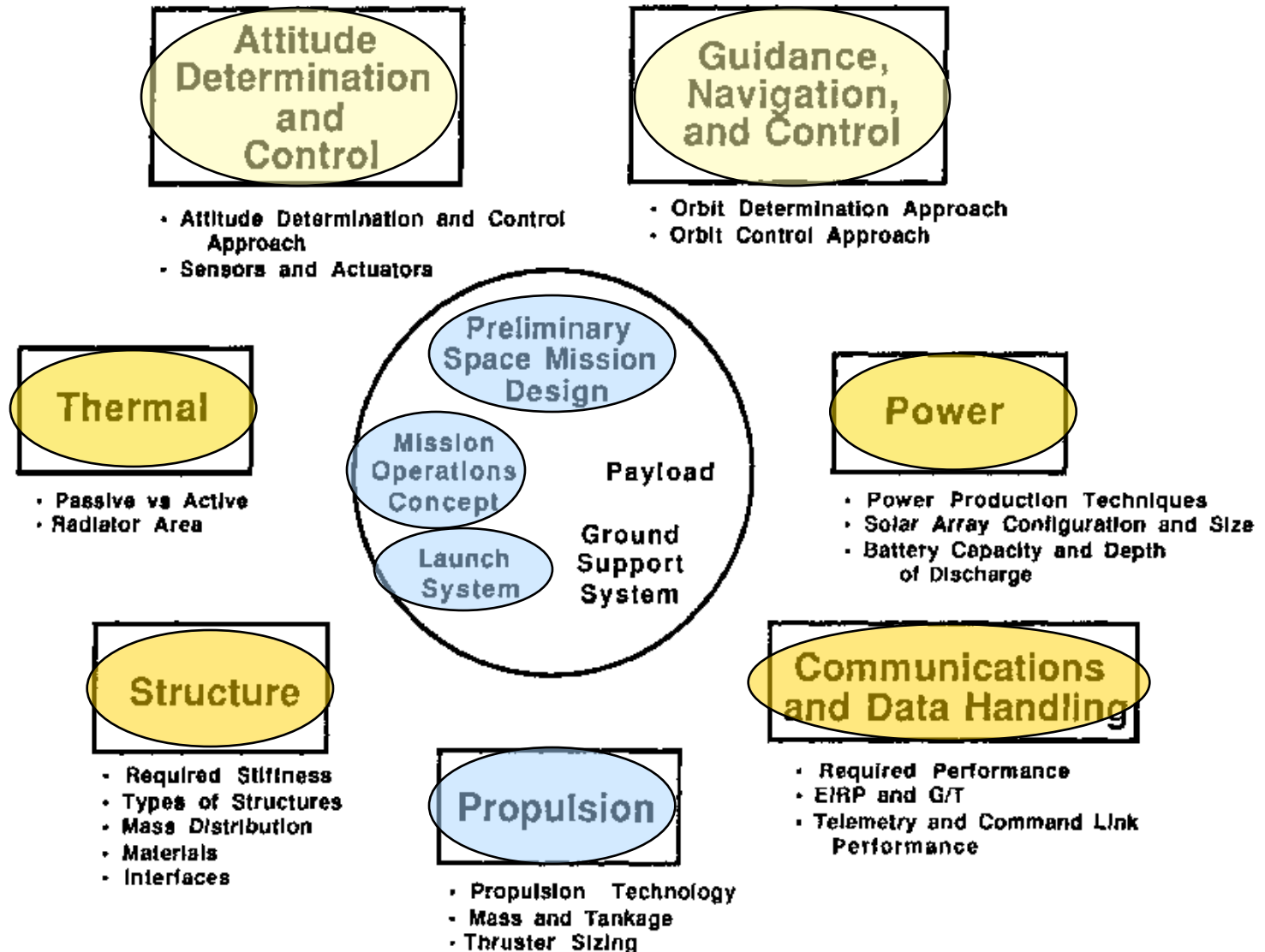

DETERMINAZIONE E CONTROLLO ASSETTO 1/5

A satellite must maintain a certain attitude while in orbit

- to allow precise pointing of an antenna toward the Earth,
- to allow the accurate orientation of observation instruments toward the object being observed,
- and to direct solar panels toward the Sun.

But the satellite receives interference from such phenomena as the Earth's gravitational and magnetic fields, and the solar wind.

These phenomena tend to disturb the satellite's attitude, so it is necessary to control attitude to keep the satellite stable.

<http://spaceinfo.jaxa.jp/>

DETERMINAZIONE E CONTROLLO ASSETTO 2/5

- The spacecraft needs an Attitude Determination and Control System (ADCS)
- To do the **determination** function requires knowledge of kinematics
- Attitude is determined using sensors
- To do the **control** function requires knowledge of kinetics and kinematics (dynamics)
- Attitude is controlled using actuators

DETERMINAZIONE E CONTROLLO ASSETTO 3/5

Modi operativi:

- Inserzione in orbita
- Acquisizione iniziale
- Normale
- Slew
- Contingency
- Speciale

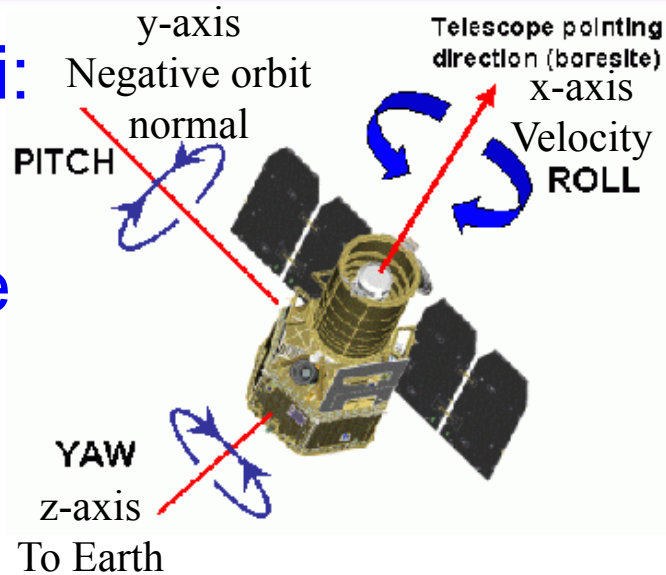

$M = 215 \text{ kg}$

$I_x = I_y = 90 \text{ kg m}^2$

$I_y = 60 \text{ kg m}^2$

Orbite attitude = 800 km, circular

Slew rate $< 0.1^\circ / \text{s}$

Pointing accuracy = 0.1°

Mission is earth looking, except one operational manoeuver per month to a target of opportunity

Mode	Description
<i>Orbit Insertion</i>	Period during and after boost while spacecraft is brought to final orbit. Options include no spacecraft control, simple spin stabilization of solid rocket motor, and full spacecraft control using liquid propulsion system.
<i>Acquisition</i>	Initial determination of attitude and stabilization of vehicle. Also may be used to recover from power upsets or emergencies.
<i>Normal, On-Station</i>	Used for the vast majority of the mission. Requirements for this mode should drive system design.
<i>Slew</i>	Reorienting the vehicle when required.
<i>Contingency, or Safe</i>	Used in emergencies if regular mode fails or is disabled. May use less power or sacrifice normal operation to meet power or thermal constraints.
<i>Special</i>	Requirements may be different for special targets or time periods, such as eclipses.

Parametri e requisiti

determinazione

& controllo

- ***Accuracy***
 - quanto bene misuro/controllo orientazione S/C (0.25° su 3 assi)
- ***Range***
 - intervallo angolare entro cui devo garantire *accuracy* (30° dal nadir)

controllo

- ***Jitter***
 - velocità angolare a breve termine, moto alta frequenza ($1^\circ/\text{s}$)
- ***Drift***
 - velocità angolare a lungo termine, moto bassa frequenza ($1^\circ/\text{hr}$)
- ***Settling time***
 - tempo limite per riprendere il controllo dopo una manovra

DETERMINAZIONE E CONTROLLO ASSETTO 5/5

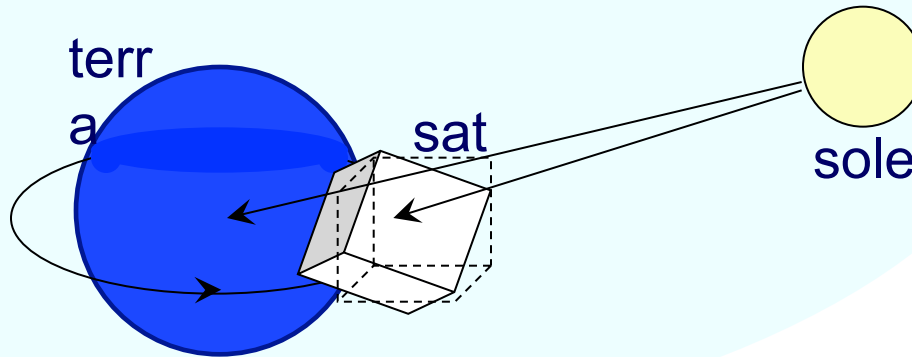

CONTROLLO:
SISTEMI ATTIVI
SISTEMI PASSIVI

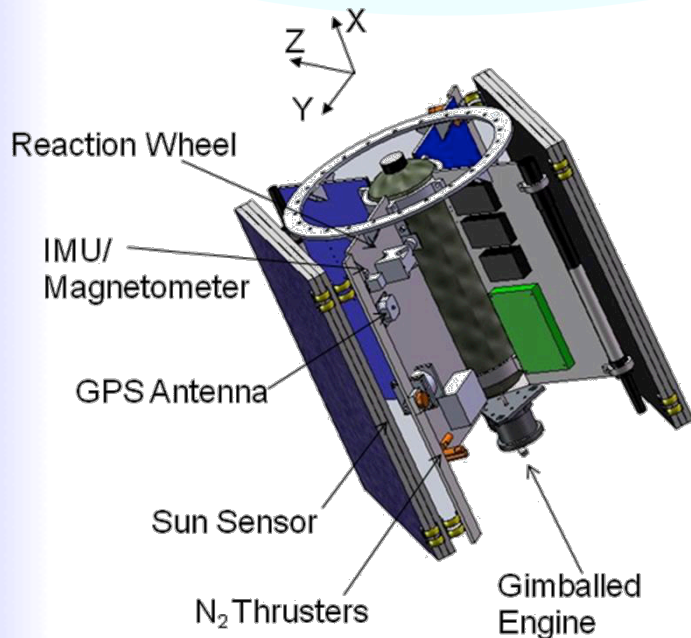

DETERMINAZIONE:
SENSORI

GPS

CELLE SOLARI,
FOTODIODI

MAGNETOMETRO

CONTROLLO PASSIVO

- Gravity gradient control
- Controllo tramite magneti permanenti
- Tecniche di controllo dello spin

CONTROLLO ATTIVO

- Controllo tramite bobine magnetiche
- Sistemi a zero momentum
- Sistemi a momentum bias
- Thrusters

Control Algorithms

- Control Algorithms are computer programs that receive input data from vehicle sensors and derive the appropriate torque commands to the actuators to rotate the vehicle to the desired attitude

Tecniche di Controllo 3/3

Equazione di Eulero

- $d\mathbf{L} / dt = \mathbf{T} = \Sigma \mathbf{M}_i$ ($\mathbf{M}_i = \mathbf{r}_i \times \mathbf{F}_i$)
- $\mathbf{L} = \mathbf{I} \cdot \boldsymbol{\omega}$ $\mathbf{T} = \mathbf{I} \cdot d\boldsymbol{\omega}/dt (\dots + \boldsymbol{\omega} \times \mathbf{I} \cdot \boldsymbol{\omega} \dots)$

CONTROLLO PASSIVO

- $f(I_x, I_y, I_z, \omega_x, \omega_y, \omega_z) = M_{dx} (\dots M_{dy}, M_{dz})$
 - $I_x \dot{\omega}_x + [(I_z - I_y) \omega_y \omega_z] = M_{dx}$
 - $I_y \dot{\omega}_y + [(I_x - I_z) \omega_z \omega_x] = M_{dy}$
 - $I_z \dot{\omega}_z + [(I_y - I_x) \omega_x \omega_y] = M_{dz}$
- Matrice nel sistema di riferimento fisso col corpo
- Sistema di riferimento principale

CONTROLLO ATTIVO

- $I_x \dot{\omega}_x + (I_z - I_y) \omega_y \omega_z = M_{dx} + M_{cx}$
- $I_y \dot{\omega}_y + (I_x - I_z) \omega_z \omega_x = M_{dy} + M_{cy}$
- $I_z \dot{\omega}_z + (I_y - I_x) \omega_x \omega_y = M_{dz} + M_{cz}$



Diagramma a Blocchi



Disturbi Ambientali

39800 km →

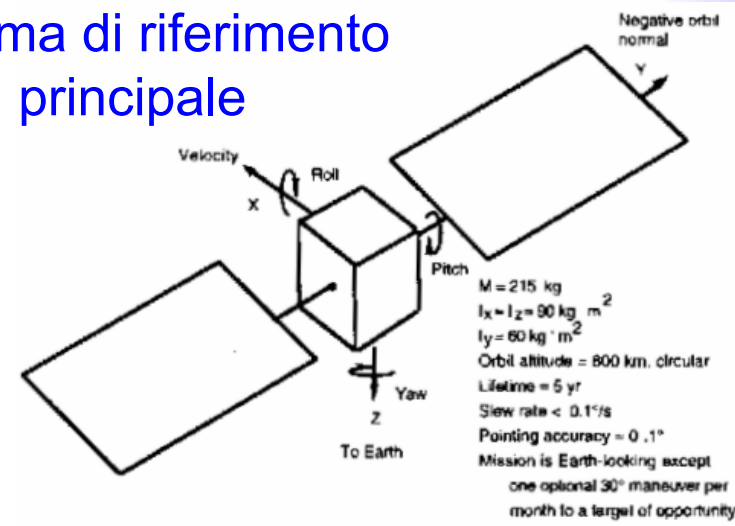
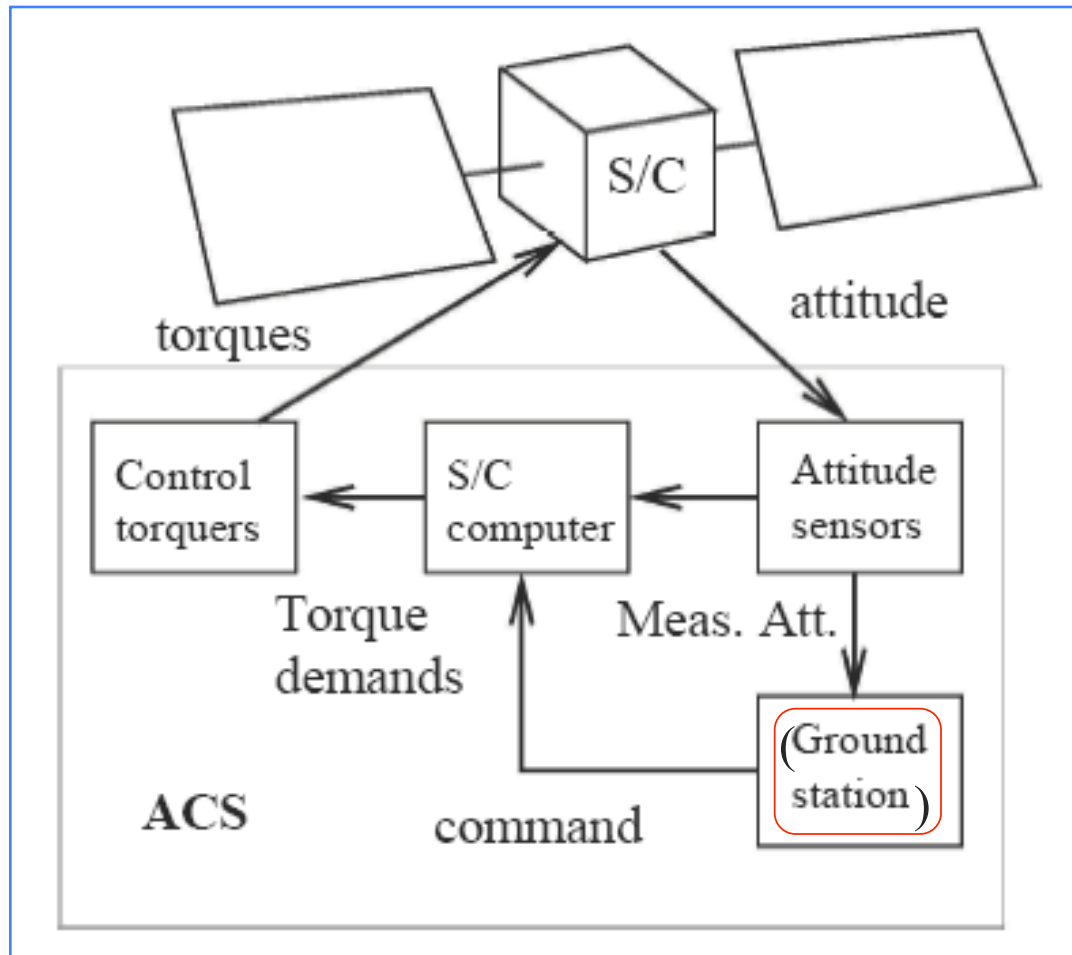
6310 km →

1000 km →

158 km →

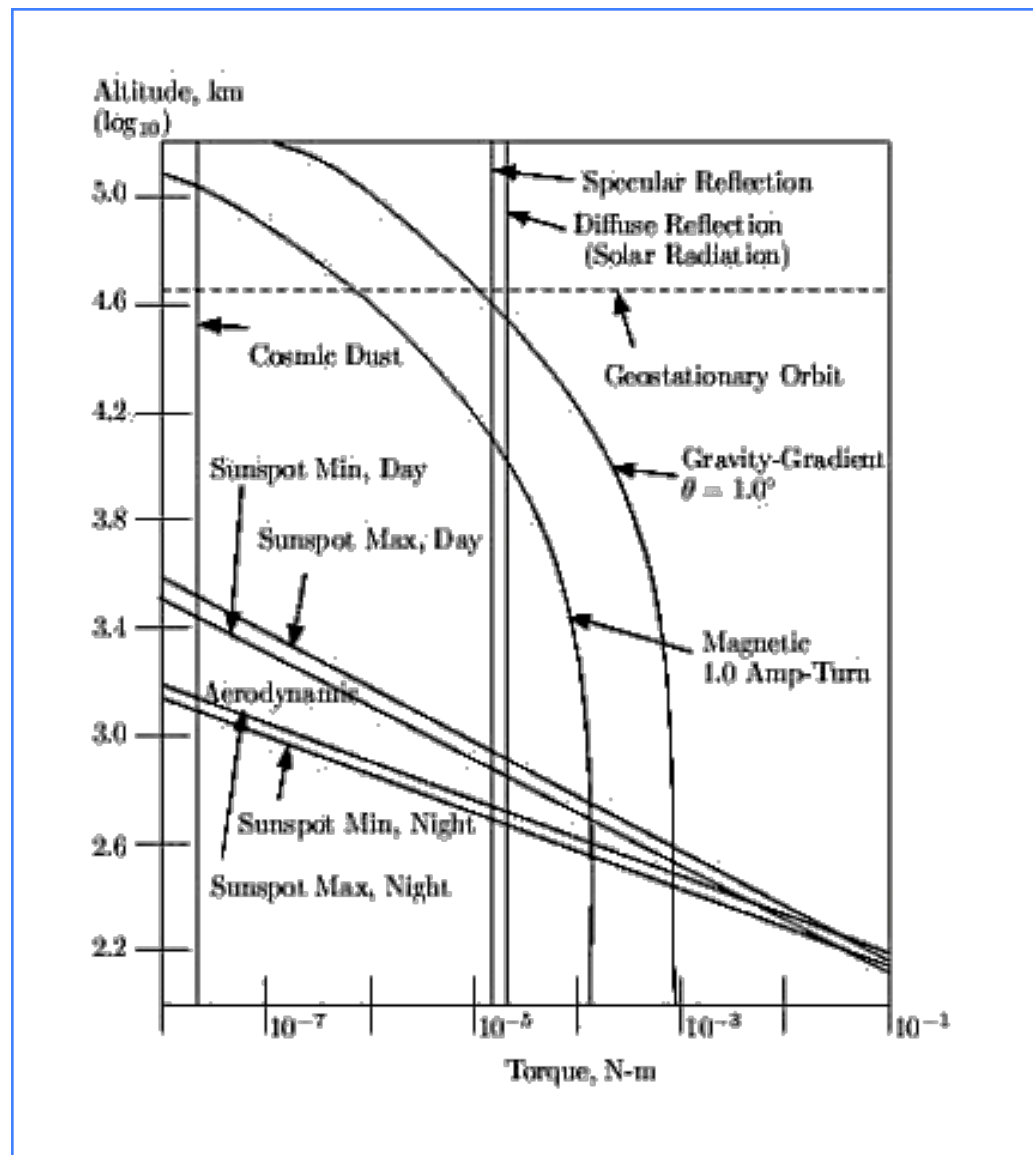

BOOM: Gradiente di Gravità

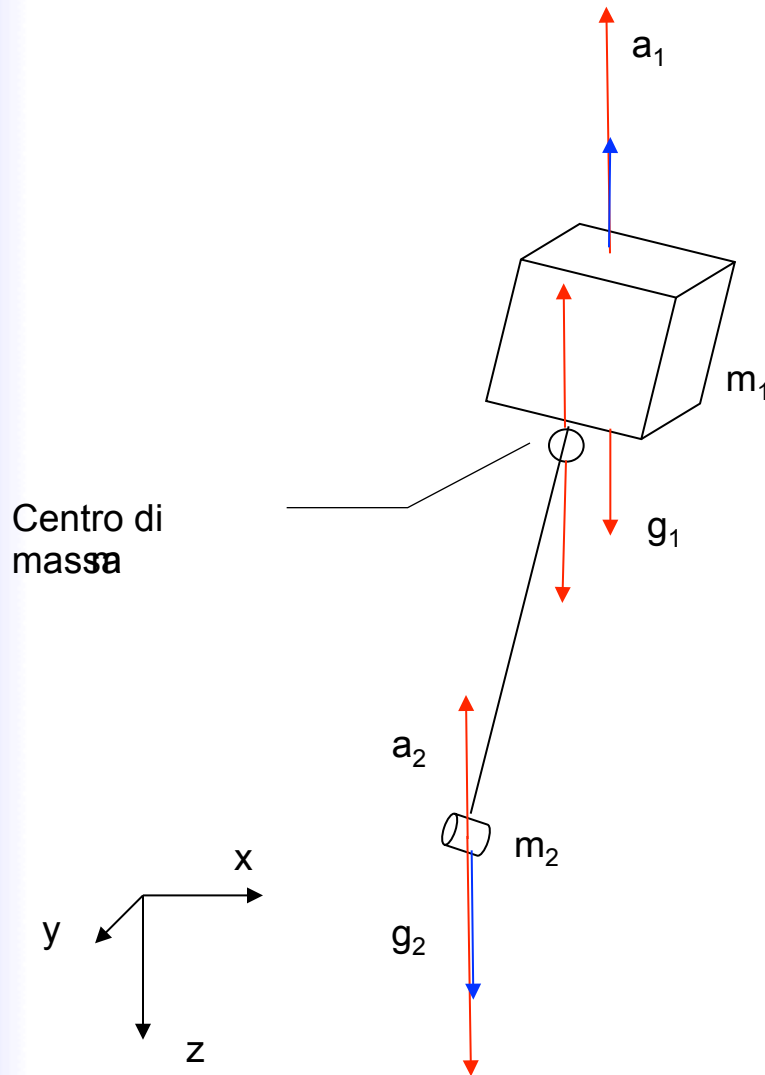

DIMENSIONAMENTO DEL BOOM

✦ CdM:

○ $F_0 = m\mu / R^2 = m\omega^2_o R$

✦ m_1 : $(\omega^2_o = \mu/R^3)$

○ $F_{g,1} = m_1\mu / R_1^2 < m_1\omega^2_o R_1$

✦ m_2 :

○ $F_{g,2} = m_2\mu / R_2^2 > m_2\omega^2_o R_2$

$$T_G = \frac{3\mu}{2a^3} |I_Z - I_{MIN}| \text{sen}(2\theta)$$

Stabilizzazione a Spin 1/2

RIGIDITA' GIROSCOPICA

$$L = I\omega$$

ω velocità angolare, I momento d'inerzia,
 $\Rightarrow L$ momento angolare (\gg)

Perturbazione \Rightarrow Forza $\Rightarrow T$ (torsione),
 \Rightarrow direzione di L varia di $d\psi$ (precessione)

\Rightarrow piccola torsione T :

$\Rightarrow d\psi/dt$ piccolo

\Rightarrow per una data torsione T :

$\Rightarrow (L \gg) d\psi/dt \ll$

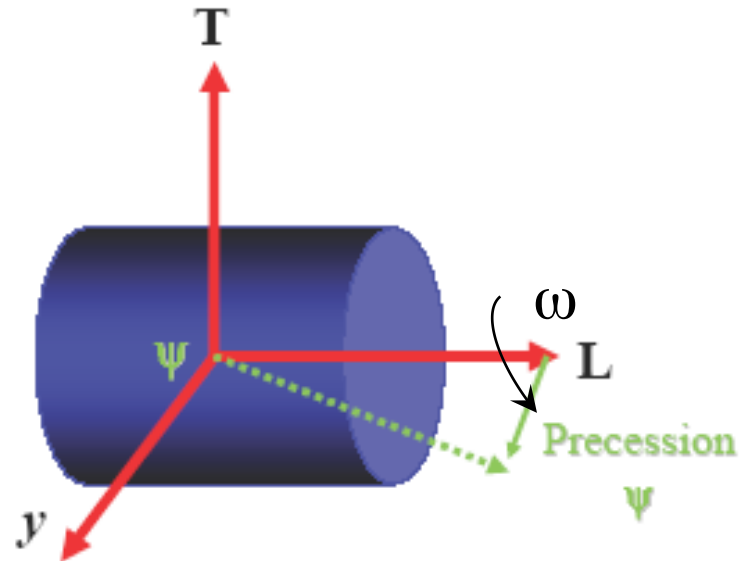

$$\frac{d\psi}{dt} \approx \frac{T}{L}$$

$$T = \frac{d\psi}{dt} \times L$$

Stabilizzazione a Spin 2/2

Valori tipici: 1 rivoluzione
al secondo

Svantaggi:

- pannelli solari ridotti
- orientamento antenne e strumenti richiedono ulteriori manovre (de-spinning)



I diversi tipi di attuatori

- Propulsori e gas jet
- Ruote di reazione e di momento
- Control moment gyro
- Magnetic torquer

Actuator	Typical Performance Range	Weight (kg)	Power (W)	Suppliers
Thrusters <ul style="list-style-type: none">• Hot gas (hydrazine)• Cold gas	0.5 to 9,000 N [*] < 5 N [*]	Variable [†] Variable [†]	N/A [†] N/A [†]	Rocket Research, Hamilton Standard, TRW, Marquardt, Walter Kidde, Hughes
Reaction & momentum wheels	0.4 to 400 N·m·s for momentum wheels at 1200 to 5000 rpm: max torques from 0.01 to 1 N·m	2 to 20	10 to 110	Bendix, GE, Honeywell
Control moment gyros (CMG)	25 to 500 N·m of torque	> 40	90 to 150	Bendix, Honeywell
Magnetic torquers	1 to 4000 A·m ² †	0.4 to 50	0.6 to 16	Ithaco, Hughes, Lockheed, McDonnell Douglas

Ruote 1/4

Momentum o Reaction Wheel

Dischi (rotori) che ruotano grazie a un motore elettrico

Quando il motore applica un momento di torsione per accelerare o rallentare il rotore, produce un momento di torsione di reazione sul corpo del satellite

Essendo un sistema chiuso, il momento angolare totale e' costante \Rightarrow qls variazione del momento angolare di una ruota comporta una variazione uguale e opposta del momento angolare del corpo del satellite

Ruote 1/4

Momentum o Reaction Wheel

Dischi (rotori) che ruotano grazie a un motore elettrico

Quando il motore applica un momento di torsione per accelerare o rallentare il rotore, produce un momento di torsione di reazione sul corpo del satellite

Essendo un sistema chiuso, il momento angolare totale è costante \Rightarrow qls variazione del momento angolare di una ruota comporta una variazione uguale e opposta del momento angolare del corpo del satellite

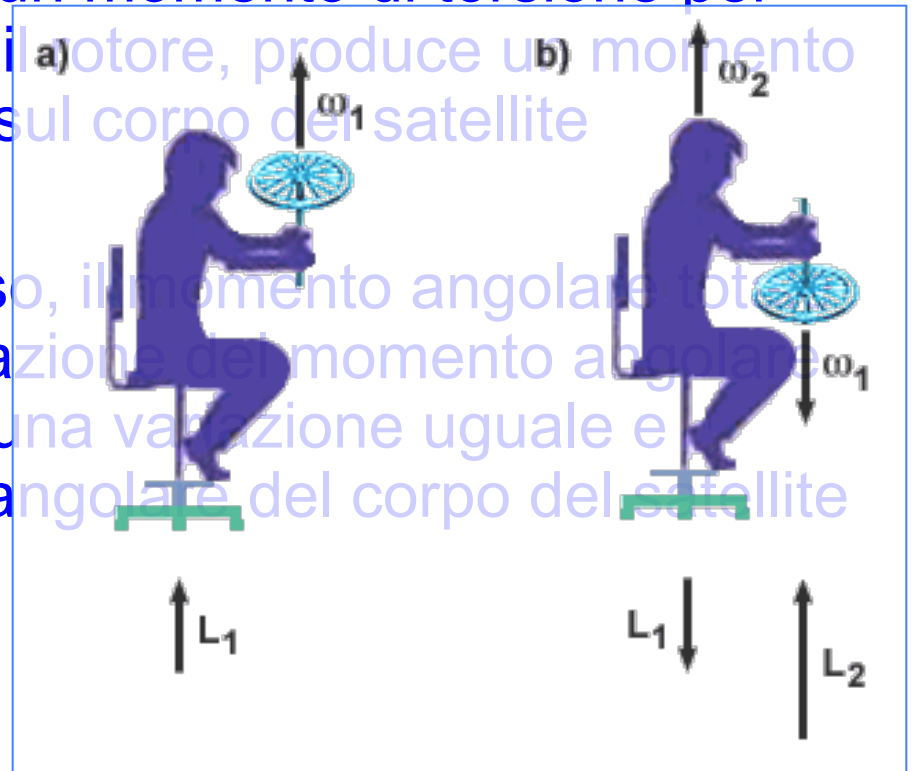

Ruote 2/4

- Asse di gimbal: fisso nel sistema rif. corpo
- Asse di spin controllato dal motore di gimbal
- Velocita' di spin controllata dal motore della ruota
- Angoli di gimbal fissi:
 - “momentum wheel” (MW)
 - “reaction wheel” (RW)
- Velocita' di ruota fissa:
 - “control moment gyro” (CMG)

L'asse di rotazione fissato per ogni ruota \Rightarrow una ruota puo' agire solo su un asse \Rightarrow almeno tre ruote per controllare il satellite su tre assi

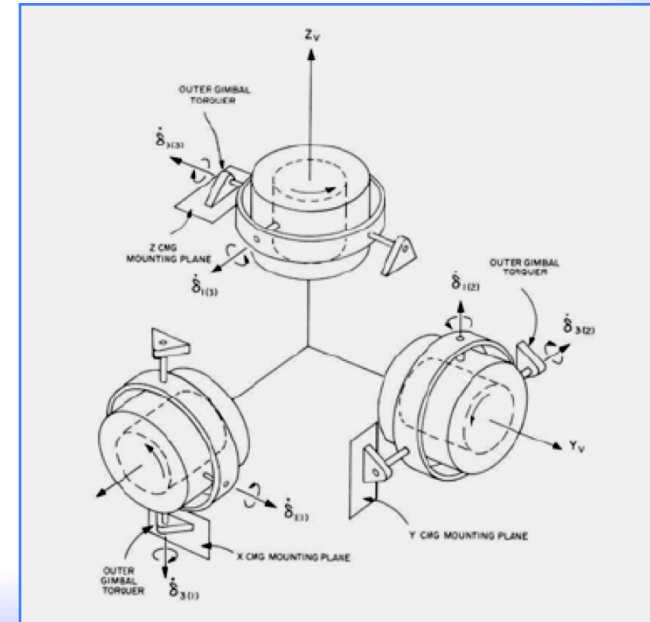
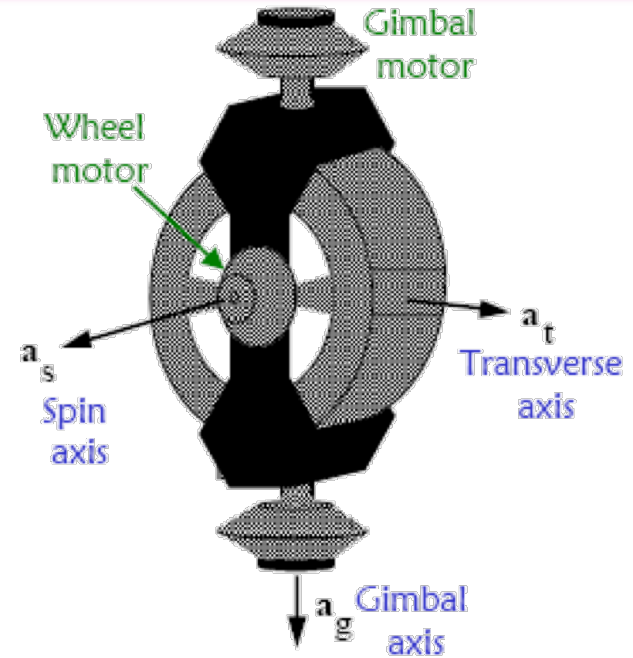

Ruote 3/4

Se le ruote sono usate ripetutamente per contrastare una torsione sempre nello stesso senso, le ruote possono superare la loro velocità massima \Rightarrow devono essere “dumpate” (thrusters or magnetic torquers)

- **Ruote di reazione:** velocità nominale zero
 - Il motore elettrico fa ruotare la RW per torcere la S/C
 - Risposta veloce
 - Saturazione può essere un problema
 - Usate quando la torsione è richiesta periodicamente
- **Ruote di momento:** velocità nominale alta (~6000 rpm) per fornire rigidità giroscopica
 - Range permesso: +/- 10% della velocità media

Ruote 4/4

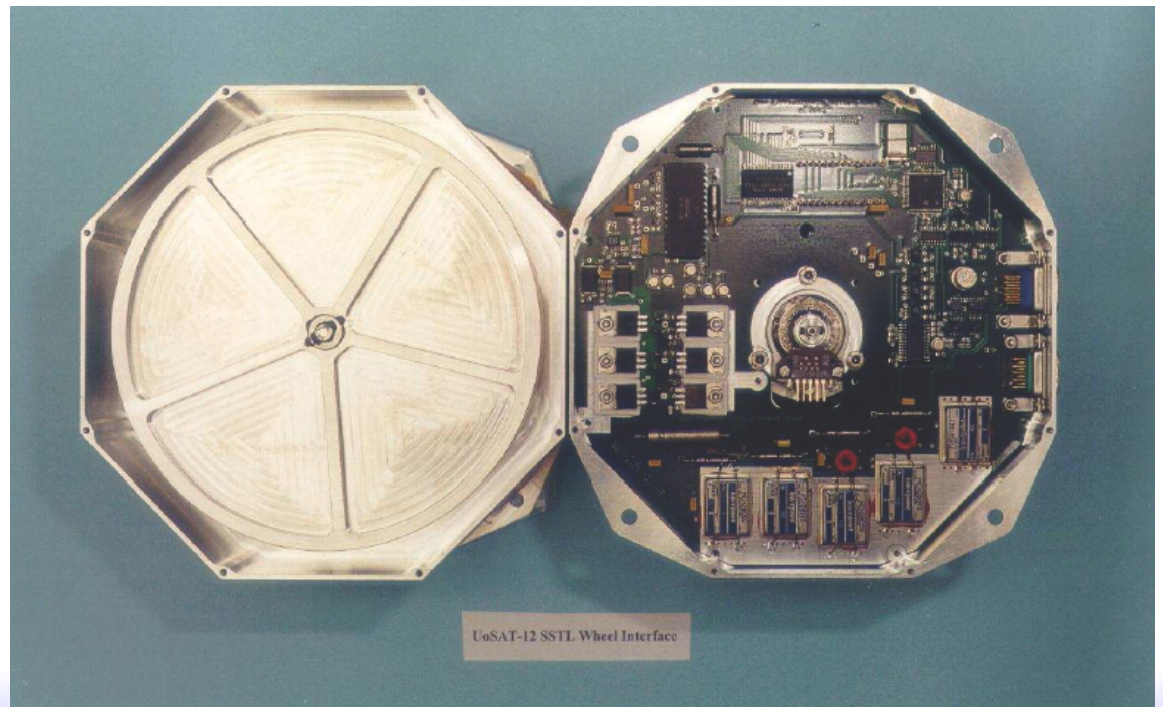
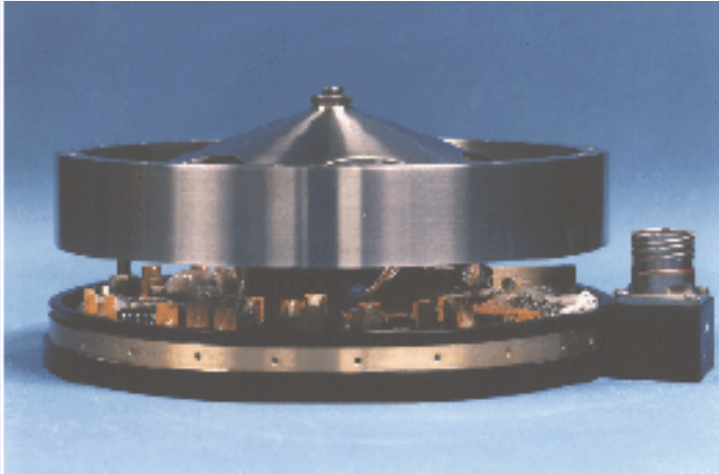

Giroscopi

- ✦ Forniscono alti livelli di controllo (100x ruote convenzionali)
- ✦ Il sistema di controllo molto più complesso delle ruote convenzionali
- ✦ Pesanti, alti consumi, rumorosi, vibrazioni

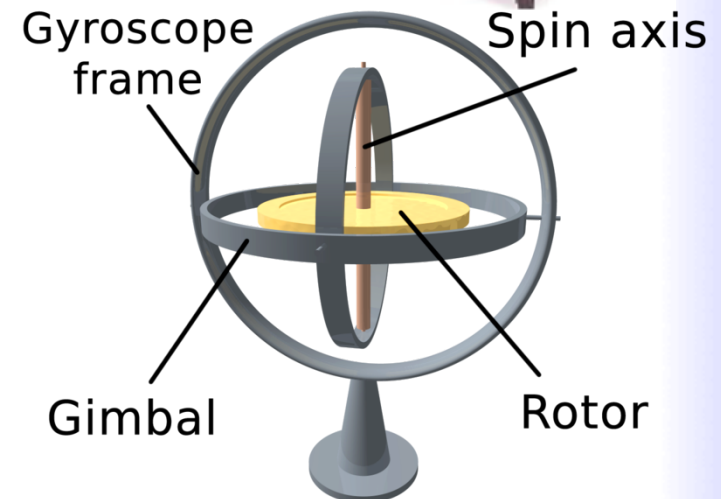

Magnetic Torquer 1/2

Il campo magnetico della S/C (momento di dipolo \mathbf{m}) interagisce con quello della Terra (\mathbf{B}) producendo un momento di torsione \mathbf{T} :

$$\mathbf{T} = \mathbf{m} \times \mathbf{B}$$

Torque rods: bobine scelte e posizionate opportunamente, percorse da correnti variabili per controllare l'assetto

$$\mathbf{T} = nIA (\mathbf{c} \times \mathbf{B})$$

n =no. di spire, I = corrente, A = sezione trasversale della bobina, \mathbf{c} = versore dell'asse della bobina

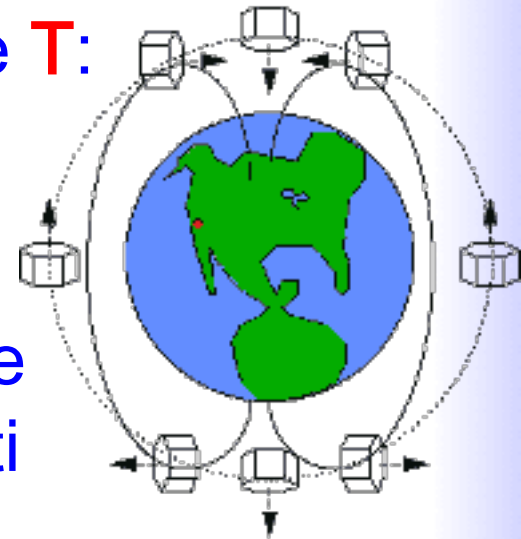

Magnetic Torquer 2/2

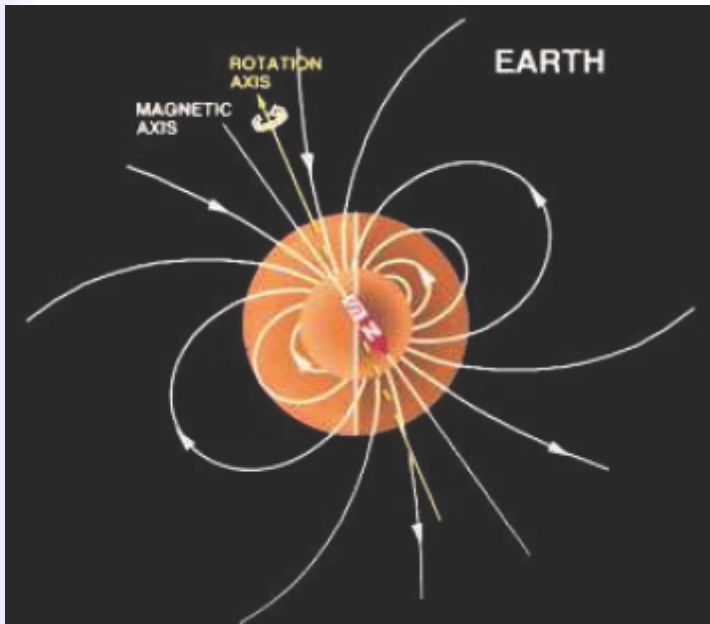

- ✦ Magnetic torquers sono efficaci anche fino alle GEO, ma il CM della Terra decresce velocemente con l' altezza
- ✦ Questi sistemi non richiedono carburante e sono controllabili (ma sistema di controllo complesso) e devono essere posizionati accuratamente
- ✦ Sono utilizzati anche per “momentum dumping” ...

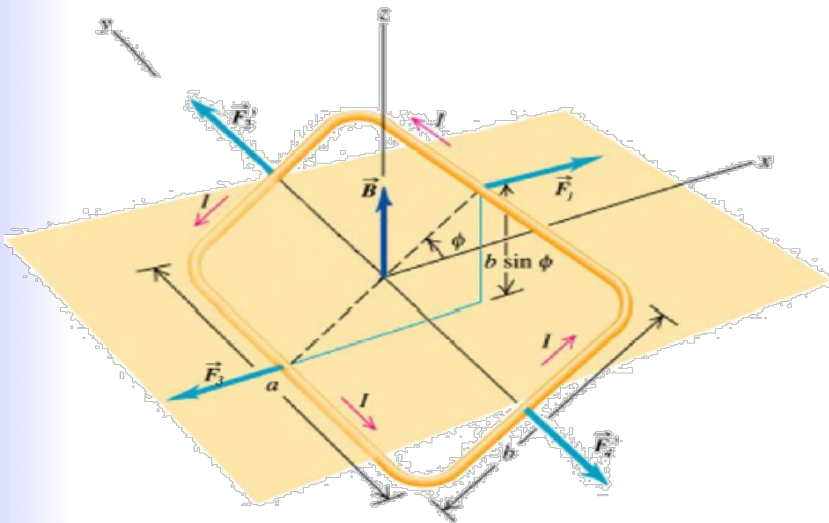

Momenti

Sommario

p. 366

SMAD

(tab.

11-9A)

Disturbance	Type	Influenced Primarily by	Formula
Gravity gradient	Constant torque for Earth-oriented vehicle, cyclic for inertially oriented vehicle	<ul style="list-style-type: none"> Spacecraft inertias Orbit altitude 	$T_g = \frac{3\mu}{2R^3} I_z - I_y \sin(2\theta)$ <p>where T_g is the max gravity torque; μ is the Earth's gravity constant ($3.986 \times 10^{14} \text{ m}^3/\text{s}^2$); R is orbit radius (m), θ is the maximum deviation of the Z axis from local vertical in radians, and I_x and I_y are moments of inertia about z and y (or x, if smaller) axes in kg m^2.</p>
Solar radiation	Cyclic torque on Earth-oriented vehicle, constant for solar-oriented vehicle or platform	<ul style="list-style-type: none"> Spacecraft geometry Spacecraft surface reflectivity Spacecraft geometry and cg location 	<p>Solar radiation pressure, T_{sp} is highly dependent on the type of surface being illuminated. A surface is either transparent, absorbent, or a reflector, but most surfaces are a combination of the three. Reflectors are classed as diffuse or specular. In general, solar arrays are absorbers and the spacecraft body is a reflector. The worst case solar radiation torque is</p> $T_{sp} = F(c_{ps} - c_g)$ <p>where $F = \frac{F_s}{c} A_s (1+q) \cos i$ and F_s is the solar constant, 1358 W/m^2, c is the speed of light, $3 \times 10^8 \text{ m/s}$, A_s is the surface area, c_{ps} is the location of the center of solar pressure, c_g is the center of gravity, q is the reflectance factor (ranging from 0 to 1, we use 0.6), and i is the angle of incidence of the Sun.</p>
Magnetic field	Cyclic	<ul style="list-style-type: none"> Orbit altitude Residual spacecraft magnetic dipole Orbit inclination 	$T_m = DB$ <p>where T_m is the magnetic torque on the spacecraft; D is the residual dipole of the vehicle in amp-turn m^2 (A m^2), and B is the Earth's magnetic field in tesla. B can be approximated as $2M/R^3$ for a polar orbit to half that at the equator. M is the magnetic moment of the Earth, $7.96 \times 10^{15} \text{ tesla m}^3$, and R is the radius from dipole (Earth) center to spacecraft in m.</p>
Aerodynamic	Constant for Earth-oriented vehicles, variable for inertially oriented vehicle	<ul style="list-style-type: none"> Orbit altitude Spacecraft geometry and cg location 	<p>Atmospheric density for low orbits varies significantly with solar activity.</p> $T_a = F(c_{pa} - c_g)$ <p>where $F = 0.5 [\rho C_d AV^2]$; F being the force; C_d the drag coefficient (usually between 2 and 2.5); ρ the atmospheric density; A, the surface area; V, the spacecraft velocity; c_{pa} the center of aerodynamic pressure; and c_g the center of gravity.</p>

Tecniche di Controllo 1/3

Type	Pointing Options	Attitude Maneuverability	Typical Accuracy	Lifetime Limits
Gravity gradient	Earth local vertical only	Very limited	$\pm 5^\circ$ (two axes)	None
Gravity gradient & momentum bias wheel	Earth local vertical only	Very limited	$\pm 5^\circ$ (three axes)	Life of wheel bearings
Passive magnetic	North/south only	Very limited	$\pm 5^\circ$ (two axes)	None
Pure spin stabilization	Inertially fixed any direction Repoint with precession maneuvers	High propellant usage to move stiff momentum vector	$\pm 0.1^\circ$ to $\pm 1^\circ$ in two axes (proportional to spin rate)	Thruster propellant (if applies)*
Dual spin stabilization	Limited only by articulation on despun platform	Momentum vector same as above Despun platform constrained by its own geometry	Same as above for spin section Despun dictated by payload reference and pointing	Thruster propellant (if applies)* Despin bearings
Bias momentum (1 wheel)	Best suited for local vertical pointing	Momentum vector of the bias wheel prefers to stay normal to orbit plane, constraining yaw maneuver	$\pm 0.1^\circ$ to $\pm 1^\circ$	Propellant (if applies)* Life of sensor and wheel bearings
Zero momentum (thruster only)	No constraints	No constraints High rates possible	$\pm 0.1^\circ$ to $\pm 5^\circ$	Propellant
Zero momentum (3 wheels)	No constraints	No constraints	$\pm 0.001^\circ$ to $\pm 1^\circ$	Propellant (if applies)* Life of sensor and wheel bearings
Zero momentum CMG	No constraints	No constraints High rates possible	$\pm 0.001^\circ$ to $\pm 1^\circ$	Propellant (if applies)* Life of sensor and

I diversi tipi di sensori 1/2

- Sensori solari
 - Analogici
 - Di presenza
 - Digitali
- Sensori stellari (star tracker)
- Sensori di orizzonte
 - ← sole/terra ~ 400
 - ← sole/terra ~ 30000
 - Terra (IR / V)
 - Luna (IR / V)
- Magnetometri
- Ricevitori GPS
- Giroscopi

Sensor	Typical Performance Range	Wt Range (kg)	Power (W)	Some Typical Suppliers
Inertial measurement unit (gyros & accelerometers)	Gyro drift rate = 0.003°/hr to 1°/hr, accel. linearity = 1 to 5 x 10 ⁻⁶ g/g ² over range of 20 to 60 g	3 to 25	10 to 200	Northrop, Bendix, Kearfott, Honeywell, Hamilton Standard, Litton, Teledyne
Sun sensors	Accuracy = 0.005° to 3°	0.5 to 2	0 to 3	Adcole, TRW, Ball Aerospace
Star sensors (scanners & mappers)	Attitude accuracy = 1 arc sec to 1 arc min 0.0003° to 0.01°	3 to 7	5 to 20	Ball Aerospace, Bendix, Honeywell, Hughes
Horizon sensors • Scanner/Pipper • Fixed head (static)	Attitude accuracy: 0.1° to 1° (LEO) <0.1° to 0.25°	2 to 5 2.5 to 3.5	5 to 10 0.3 to 5	Barnes, Ithaco, Lockheed Barnes, Lockheed
Magnetometer	Attitude accuracy = 0.5 to 3°	0.6 to 1.2	<1	Schonstedt, Develco

I diversi tipi di sensori 2/2

Sensori stellari



Sensori solari

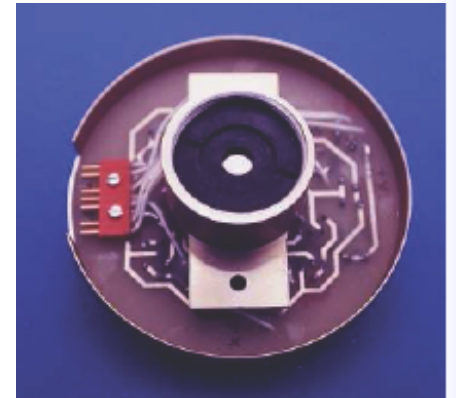
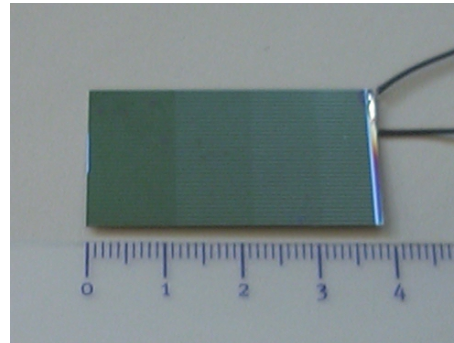
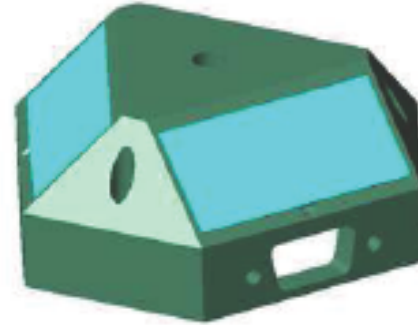

Star Trackers

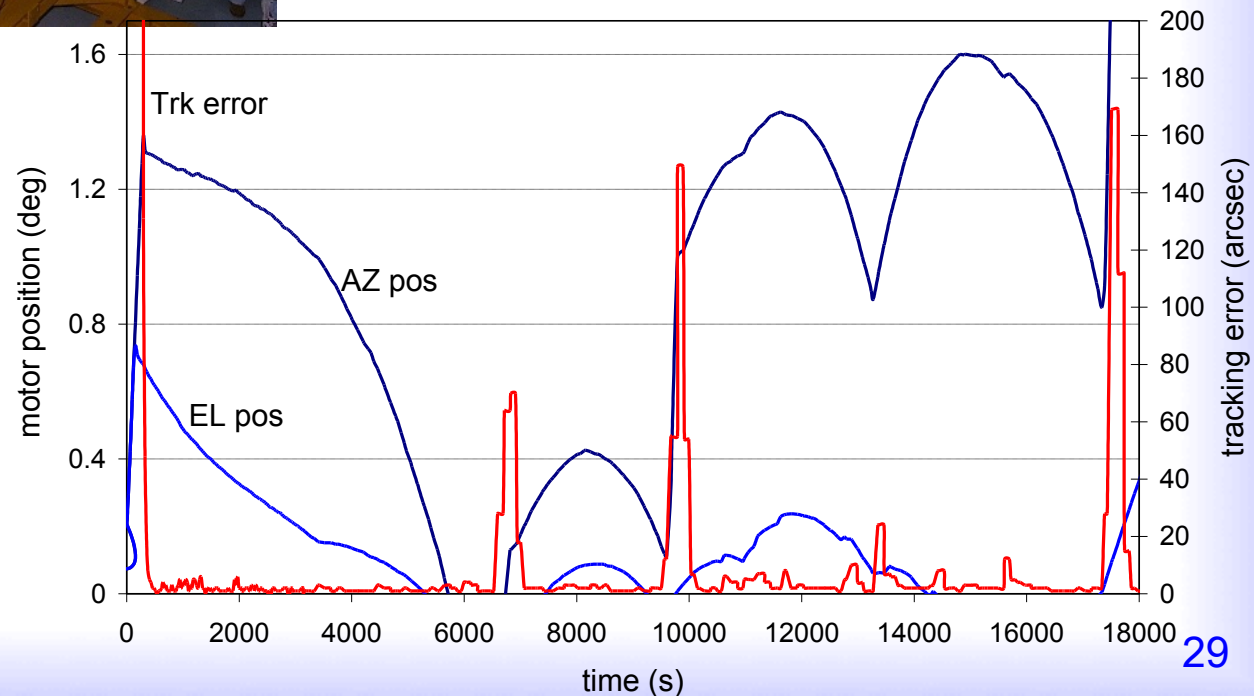
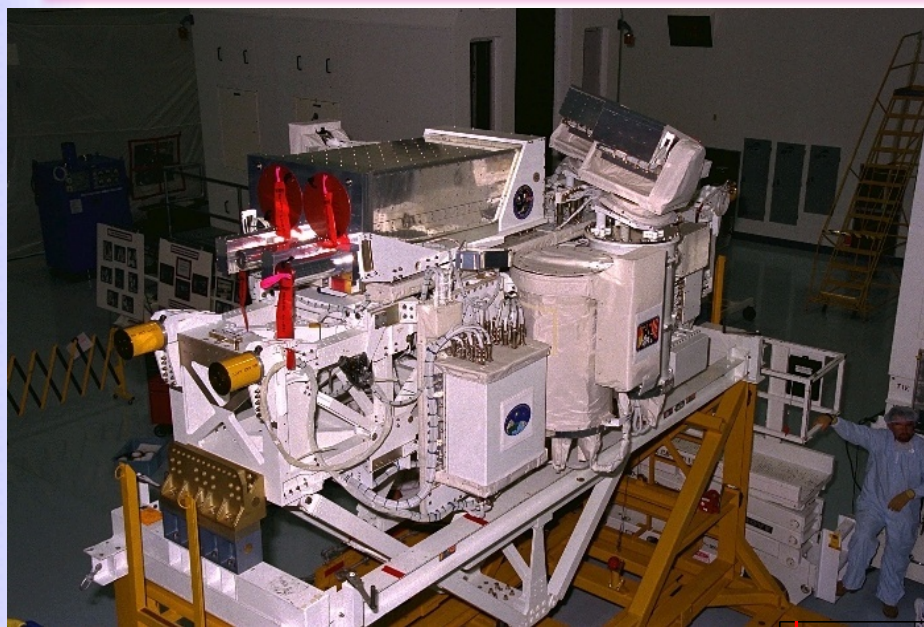

Sensori Solari Analogici

Celle solari: $I(\beta) = I_0 \cos \beta$

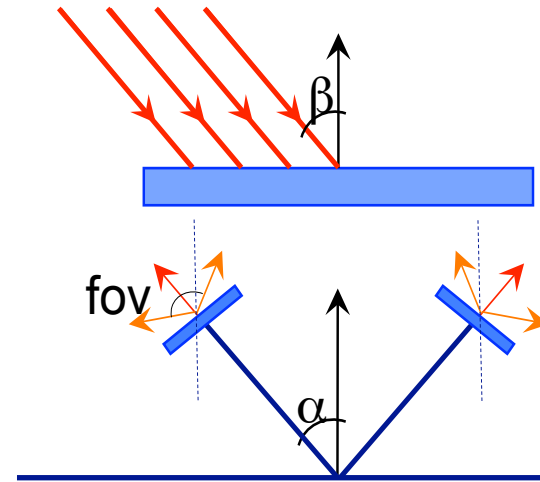
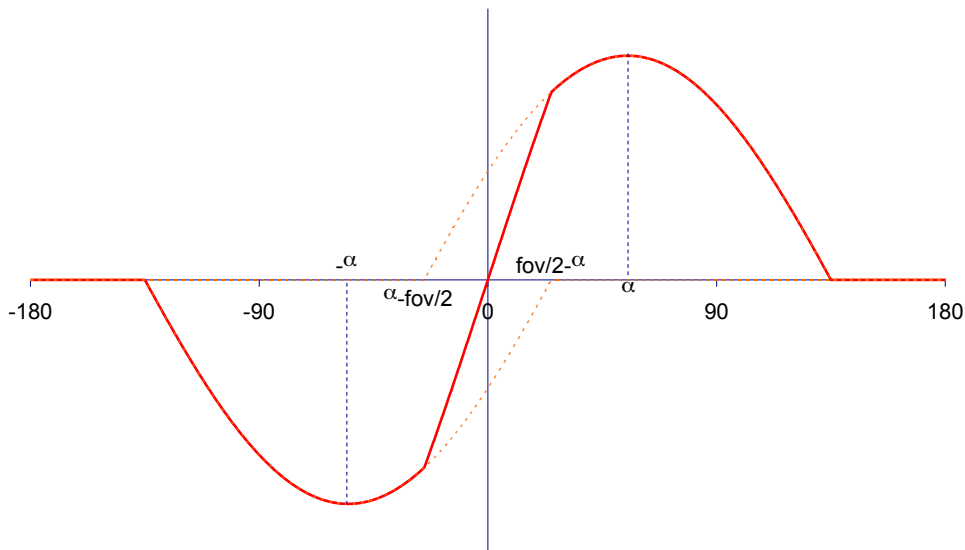

$\alpha = 55^\circ$
 $\text{fov} = 160^\circ$

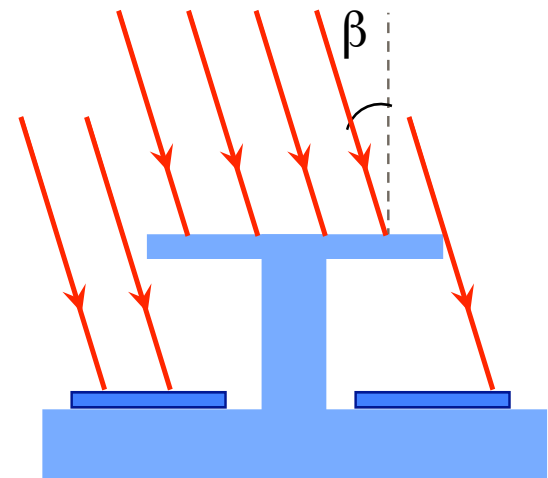
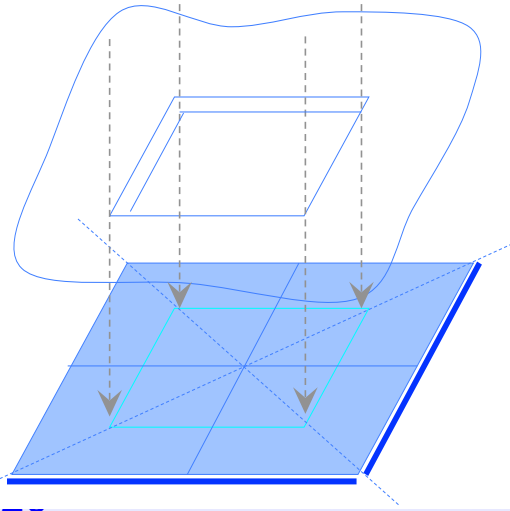

Sensori Solari di Presenza

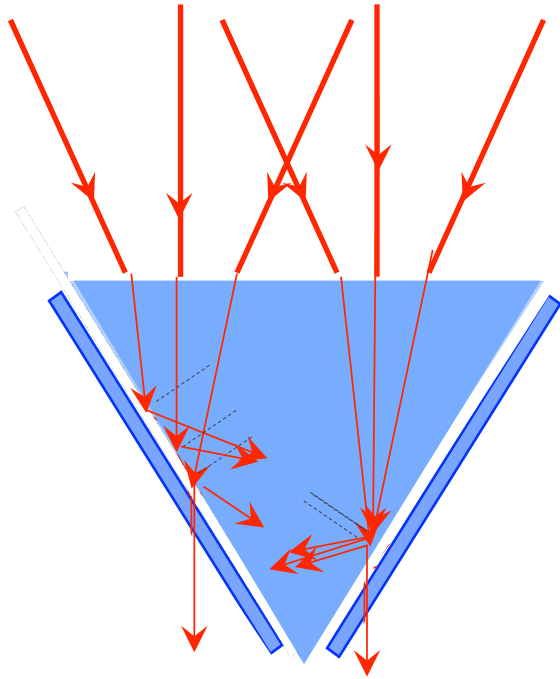

$$n \sin \gamma = 1$$

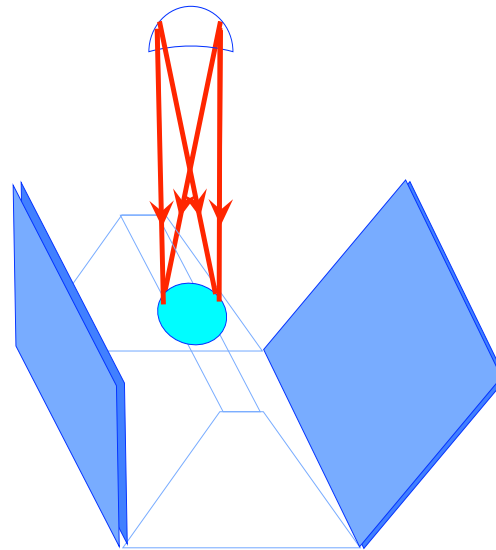
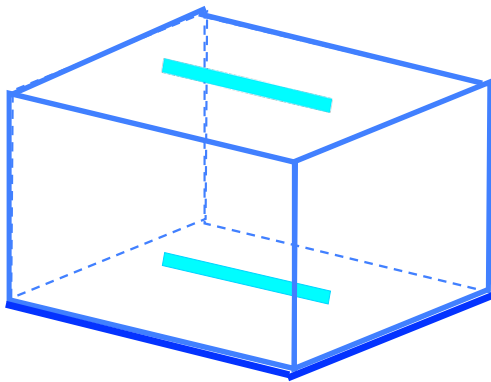

on axis



off axis

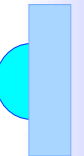

saturation

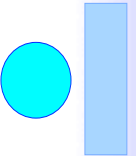

Sensori Solari Digitali

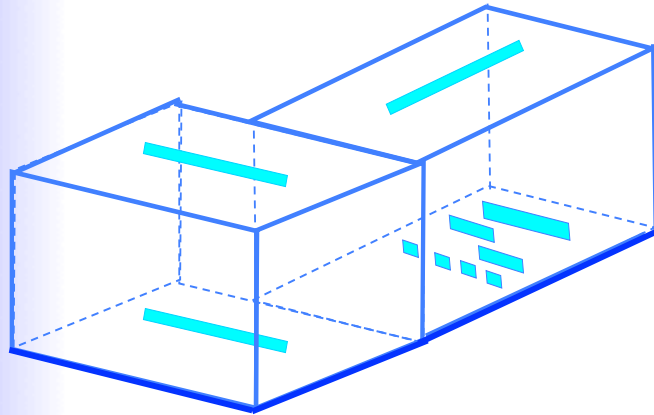

Componente di misura

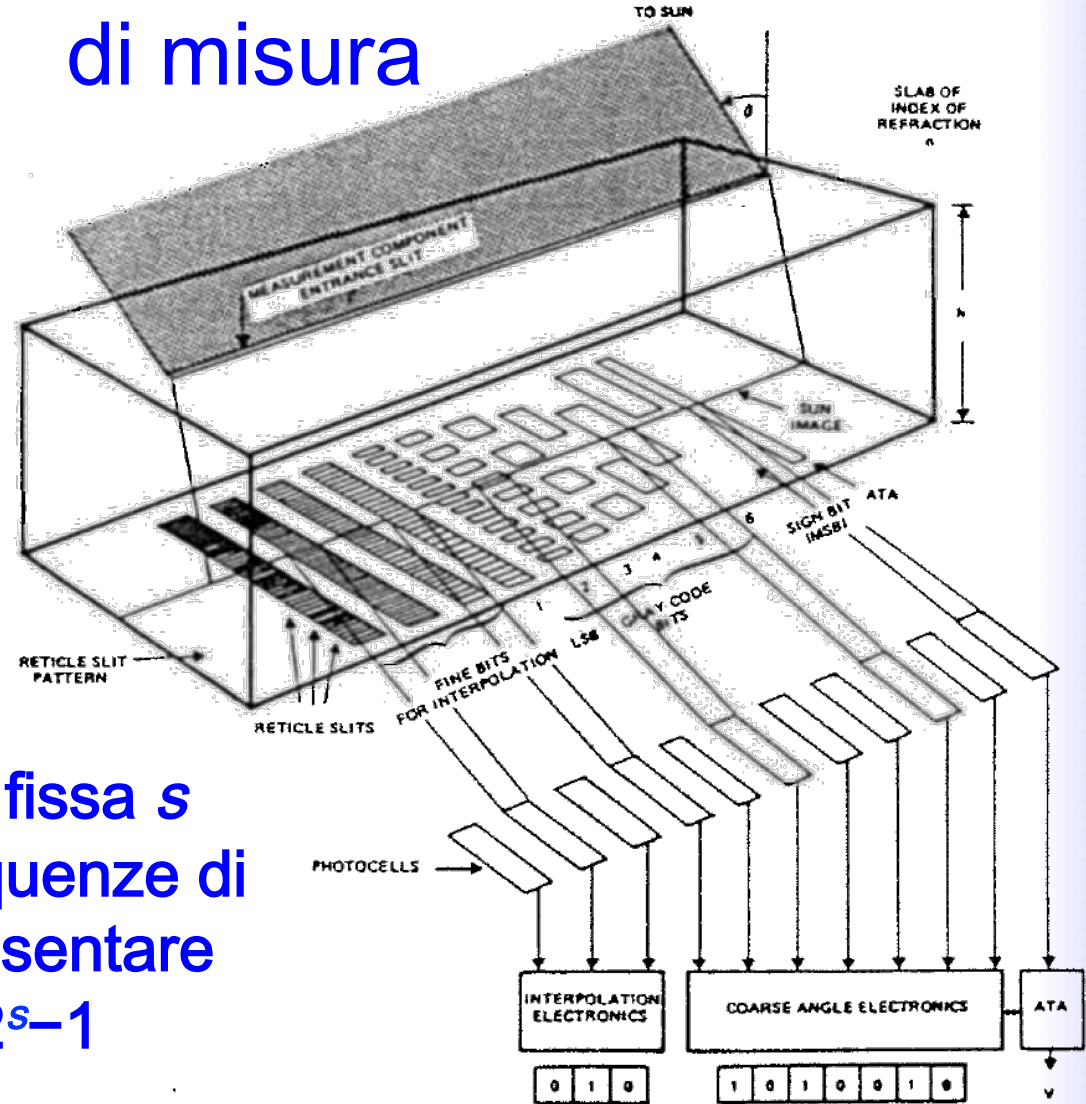

Componente di comando

Codice Gray

codice binario a lunghezza fissa s costituito da tutte le 2^s sequenze di s bit e consente di rappresentare tutti gli interi da 0 a 2^s-1

Tecniche di controllo

RICHIESTE	EFFETTI SUL SATELLITE	EFFETTI SULL'ADCS
<p>PUNTATORI TERRESTRI</p> <ul style="list-style-type: none"> - puntamento al nadir - scanning - puntamento via dal nadir 	<ul style="list-style-type: none"> - il gradiente di gravità è buono per basse precisioni (> 1 grado) - la stabilizzazione sui tre assi è accettabile con riferimento alla verticale locale 	<p>SE VIENE USATO IL GRADIENTE DI GRAVITÀ</p> <p>SONO RICHIESTI I SEGUENTI DISPOSITIVI:</p> <ul style="list-style-type: none"> - boom per creare il gradiente di gravità e smorzatori di librazione - sensori solari, magnetometri o sensori di orizzonte per la determinazione dell'assetto - una ruota di momento per il controllo dell'imbardata <p>SE VIENE USATO IL CONTROLLO SUI TRE ASSI</p> <p>SONO RICHIESTI I SEGUENTI DISPOSITIVI:</p> <ul style="list-style-type: none"> - sensori di orizzonte per il riferimento verticale (rollie e beccheggio) - un sensore stellare o solare per il riferimento lungo il terzo asse e per la determinazione dell'assetto - ruote di reazione o di momento per un puntamento fine - sistemi a reazione (propulsori) per il puntamento grezzo e per lo smorzamento dei momenti angolari - gli attuatori magnetici (magnetic torquer) possono anch'essi essere utilizzati per smorzare i momenti
<p>PUNTATORI INERZIALI</p> <ul style="list-style-type: none"> - Sole - target celesti - altri obiettivi 	<ul style="list-style-type: none"> - il gradiente di gravità non è adeguato - la stabilizzazione di spin va bene per precisioni intermedie, con poche manovre d'assetto - il controllo sui tre assi è il più versatile per frequenti ri-orientamenti 	<p>SE VIENE USATO IL CONTROLLO PER MEZZO DELLO SPIN</p> <p>SONO RICHIESTI I SEGUENTI DISPOSITIVI:</p> <ul style="list-style-type: none"> - una piattaforma non spinnata, per favorire il puntamento del payload e dei sensori d'assetto - propulsori per ri-orientare il vettore di momento angolare - smorzatori di nutazione <p>SE VIENE USATO IL CONTROLLO SUI TRE ASSI</p> <p>SONO RICHIESTI I SEGUENTI DISPOSITIVI:</p> <ul style="list-style-type: none"> - i sensori solari e stellari sono quelli tipicamente usati - i tipici attuatori sono le ruote di reazione e i propulsori - possono essere richiesti carichi (payload) articolati per effettuare scansioni

Tecniche di controllo

PRECISIONE RICHIESTA	EFFETTI SUL SATELLITE	EFFETTI SULL'ADCS
> 5 gradi	<ul style="list-style-type: none"> - consente la stabilizzazione per mezzo del gradiente di gravità - permette una maggiore limitazione dei costi 	<p>SENZA DETERMINAZIONE DELL'ASSETTO:</p> <ul style="list-style-type: none"> - non è richiesto nessun sensore per la stabilizzazione con gradiente di gravità - gli unici attuatori richiesti sono: un motore per il boem, uno smorzatore e una ruota di momentum bias <p>CON DETERMINAZIONE DELL'ASSETTO:</p> <ul style="list-style-type: none"> - sensori solari e magnetometri sono adeguati per la determinazione dell'assetto con precisione inferiore ai 2 gradi - precisioni maggiori di 2 gradi richiedono sensori stellari e sensori di orizzonte
da 1 a 5 gradi	<ul style="list-style-type: none"> - non è utilizzabile il gradiente di gravità - la stabilizzazione di spin è attuabile se la rigidità giroscopica è sufficiente - la stabilizzazione sui tre assi lavora bene 	<ul style="list-style-type: none"> - fra i sensori, i più adeguati potrebbero essere quelli solari e ad orizzonte, specialmente per uno spinner - la stabilizzazione sui tre assi richiede, come attuatori, un sistema di ruote che risparmiino propellente per missioni di lunga durata - come attuatori di spinner, propulsori e smorzatori risultano adeguati - magnetic torquer (e magnetometro) risultano utili
da 0.1 a 1 gradi	<ul style="list-style-type: none"> - stabilizzazione sui tre assi e momentum bias attuabili - dual spin stabilization anche attuabile 	<ul style="list-style-type: none"> - il bisogno di accurati riferimenti d'assetto portano all'utilizzo di sensori stellari e di orizzonte - utilizzo di ruote di reazione affiancate da razzetti per la desaturazione e per un controllo grezzo - magnetic torquer utilizzabili per veicoli leggeri (è richiesta anche un magnetometro)
< 0.1 gradi	<ul style="list-style-type: none"> - stabilizzazione sui tre assi diventa indispensabile - può richiedere carichi articolati e isolati dalle vibrazioni 	<ul style="list-style-type: none"> - il bisogno di accurati riferimenti d'assetto impongono l'utilizzo dei sensori stellari - utilizzo di ruote di reazione affiancate da razzetti per la desaturazione e per un controllo grezzo - le leggi di controllo e i calcoli necessari diventano molto più complicati

ESEMPIO: BOOM+BOBINA

BOBINA

Compromesso tra massa minima e momento magnetico massimo

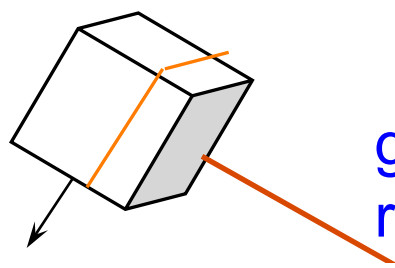

Con questa scelta AtmoCube sarà in grado di soddisfare i requisiti di missione:

BOOM

Compromesso tra massimo gradiente c

una faccia rivolta verso il nadir per mantenere l'antenna rivolta verso Terra

una faccia rivolta nella direzione del moto per il calcolo della densità atmosferica

g	Altezza (km)	$T_{AERODINAMICA}$ (Nm)	$T_{GGRAVITA'}$ (Nm)	
	650	<i>min sol</i> 1.347×10^{-9} <i>max sol</i> 3.890×10^{-8}	1.427×10^{-7}	
	500	1.350×10^{-8} 2.711×10^{-7}	1.523×10^{-7}	4.138×10^{-6} 5.668×10^{-6}
	400	1.120×10^{-7} 1.154×10^{-6}	1.590×10^{-7}	4.324×10^{-6} 5.923×10^{-6}
	300	1.270×10^{-6} 6.144×10^{-6}	1.664×10^{-7}	4.521×10^{-6} 6.193×10^{-6}



Esercizio 1/2

- Stimare i momenti di torsione esterni (di disturbo) che agiscono sulla S/C
- Supponendo di avere un sistema di 3 RW ($R=0.075$ m, vel. spin=1000 rpm), stimare quale debba essere la capacità di immagazzinamento di momento ($L=Torsione \times tempo$ accumulo) e la massa di ciascuna RW

◆ Suggestioni tab 11.12 smad

○ $I_{cilindro} = \frac{1}{2} m r^2$
(lungo l'asse longitudinale)

○ $I_{cilindro} = m(r^2/4 + l^2/12)$
(lungo l'asse trasversale)

○ $L = 0.707 T_D (\tau/4) \quad RW$

○ $L \cdot \theta = T_D (\tau/4) \quad MW$

$T_D =$ torsione di disturbo

$\tau =$ periodo orbitale

S/C characteristics

mass	2089 kg
length	4 m
diameter	2.6 m
coeff. reflectivity	0.6
magnetic dipole	2.5 A m ²
drag coeff.	2.5
diff. center pressure / center gravity	0.40 m

Operational characteristics

orbit altitude	600 km
max angular dev. from local vertical	1 deg
mission lifetime	5 years

Esercizio 2/2

- Supponendo di avere un sistema di 2 thruster (posti ai bordi del cilindro in posizione opposta) per smorzare ogni RW (una volta al giorno, $\Delta t = 1$ s, $I_{sp} = 320$ s), valutare:
 - la spinta di ciascun thrust
 - Il numero totale di impulsi per tutta la vita del satellite
 - il propellente necessario

◆ Suggestimenti:

- $F = L / (\ell \Delta t)$

F =thrust, L =momento immagazzinato dalla ruota,

ℓ =braccio, Δt =tempo di accensione thruster

- Impulso totale = $F \Delta t$

- $I_{sp} = F / (g \Delta M / \Delta t)$

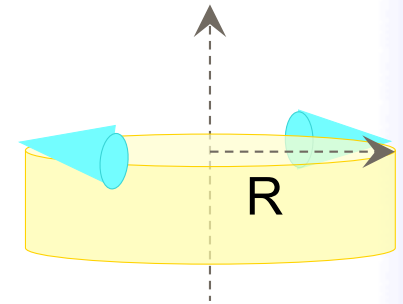

INPUTS:**S/C characteristics**

mass	2089 kg	
cylinder length	4 m	
cylinder diameter	2.6 m	
min mom. inertia	1765.205 kg m ²	1765.205
max mom. inertia	3667.935833 kg m ²	3667.9358
coeff. reflectivity	0.6	
magnetic dipole	2.5 A m ²	
drag coeff.	2.5	
diff. center pressure / center gravity	0.4 m	
area to Sun	5.309291585 m ²	
area to atmosphere	16.3362818 m ²	
max area	10.4	
v ²	57121351.19 m ² /s ²	7557.8668 m/s

operational characteristics

orbit altitude	600 km	
max angular dev. from local vertical	1 deg	0.0174533 rad
mission lifetime	5 years	157680000 s
orbit radius	6978 km	
period	5801.228868 s	
	1.611452463 hr	14.893396 numero orbite

OUTPUTS:

radius		0.075	m		
	sum		quadr sum (indip)		
REACTION WHEEL		2		1	
Storage		4.200E-01	2.279E-01	N.m.s	1 orbits
		1.141E+04	11414.741	N.m.s	lifetime
w		1000		rpm	
		104.7		rad/s	
m		1.426	0.774	kg	
			0.258	kg	
storage 1 day tot		6.255E+00	3.394E+00	N.m.s	
/wheel		2.085E+00	1.131E+00	N.m.s	

MOMENTUM WHEEL

theta		1		deg	
Storage		34.034	18.467	N.m.s	
m		115.556	62.702	kg	

THRUSTER

L		2.085E+00	N.m.s		
dt		1	s		
thrust		13.90	N		41.697684
impulso		13.90	N.s		76098.273
Isp		320	s		
Mp		0.004427634	kg		0.0265658
numero tot/wheel		1825		5475	
Mp/wheel		16.16086334	kg		
Mp tot		48.48259001	kg		

Sorgenti di Torsioni

- Thrusters (external)
- Magnetic torque (external)
- Gravity-gradient torque (external)
- Aerodynamic torques (external)
- Solar radiation pressure (external)
- Mass movement (internal)
- Momentum storage torquers (internal)

ASSETTO 2/4

Mode	Description
<i>Orbit Insertion</i>	Period during and after boost while spacecraft is brought to final orbit. Options include no spacecraft control, simple spin stabilization of solid rocket motor, and full spacecraft control using liquid propulsion system.
<i>Acquisition</i>	Initial determination of attitude and stabilization of vehicle. Also may be used to recover from power upsets or emergencies.
<i>Normal, On-Station</i>	Used for the vast majority of the mission. Requirements for this mode should drive system design.
<i>Slew</i>	Reorienting the vehicle when required.
<i>Contingency, or Safe</i>	Used in emergencies if regular mode fails or is disabled. May use less power or sacrifice normal operation to meet power or thermal constraints.
<i>Special</i>	Requirements may be different for special targets or time periods, such as eclipses.

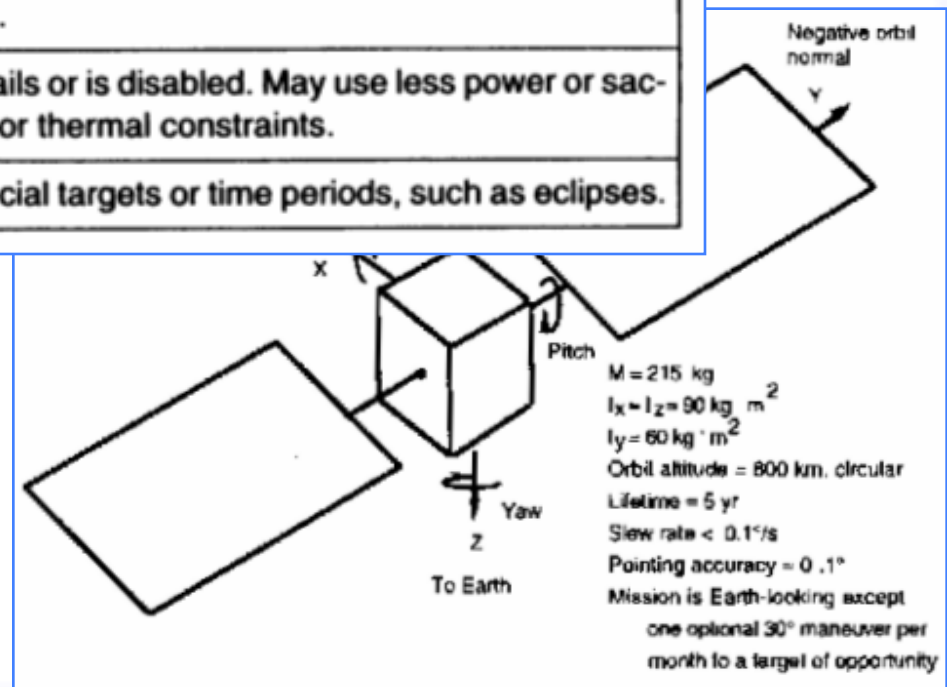

ASSETTO 3/4

Area	Definition	Examples/Comments
Determination		
<i>Accuracy</i>	How well a vehicle's orientation with respect to an absolute reference is known	0.25 deg, 3-sigma, all axes; may be real-time or post-processed on the ground
<i>Range</i>	Range of angular motion over which accuracy must be met	Any attitude within 30 deg of nadir
Control		
<i>Accuracy</i>	How well the vehicle attitude can be controlled with respect to a commanded direction	0.25 deg, 3-sigma; includes determination and control errors, may be taken with respect to an inertial or Earth-fixed reference
<i>Range</i>	Range of angular motion over which control performance must be met	All attitude, within 50 deg of nadir, within 20 deg of Sun
<i>Jitter</i>	A specified angle bound or angular rate limit on short-term, high-frequency motion	0.1 deg over 1 minute, 1 deg/s, 1 to 20 Hz; usually specified to keep spacecraft motion from blurring sensor data
<i>Drift</i>	A limit on slow, low-frequency vehicle motion. Usually expressed as angle/time.	1 deg per hour, 5 deg max. Used when vehicle may drift off target with infrequent resets (especially if actual direction is known)
<i>Settling Time</i>	Specifies allowed time to recover from maneuvers or upsets.	2 deg max motion, decaying to <0.1 deg in 1 minute; may be used to limit overshoot, ringing, or nutation

ASSETTO 3/5

Modi operativi:

- Inserzione in orbita
- Acquisizione iniziale
- Normale
- Slew
- Contingency
- Speciale

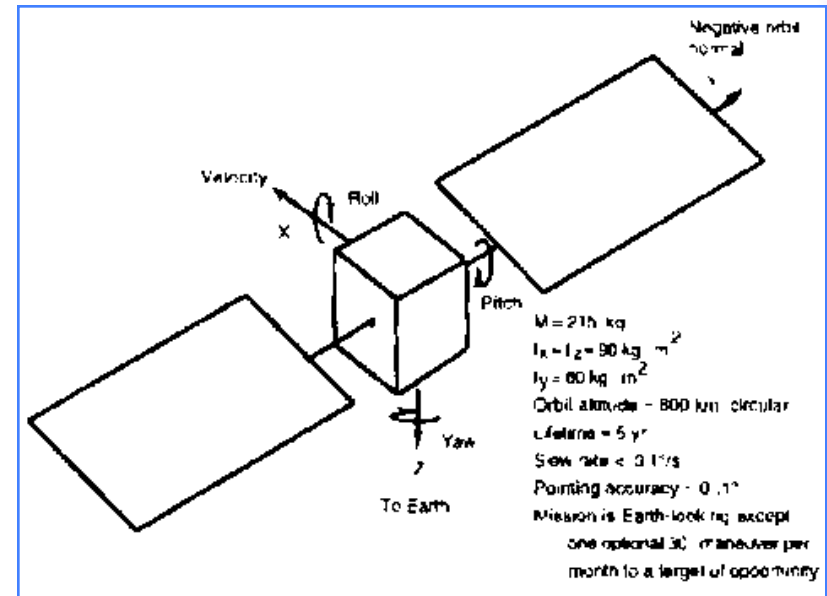

Mode	Description
<i>Orbit Insertion</i>	Period during and after boost while spacecraft is brought to final orbit. Options include no spacecraft control, simple spin stabilization of solid rocket motor, and full spacecraft control using liquid propulsion system.
<i>Acquisition</i>	Initial determination of attitude and stabilization of vehicle. Also may be used to recover from power upsets or emergencies.
<i>Normal, On-Station</i>	Used for the vast majority of the mission. Requirements for this mode should drive system design.
<i>Slew</i>	Reorienting the vehicle when required.
<i>Contingency, or Safe</i>	Used in emergencies if regular mode fails or is disabled. May use less power or sacrifice normal operation to meet power or thermal constraints.
<i>Special</i>	Requirements may be different for special targets or time periods, such as eclipses.