



A.A. 2020-2021

Corso di Laurea Magistrale in GEOSCIENZE

***Metodi Elettromagnetici in Geofisica (6 CFU)
- MEMAG -***

**UD-4b: *Ground Penetrating Radar
GPR - methods***

Docente: Emanuele Forte

Tel. 040/5582271-2274

e-mail: eforte@units.it

Ground Penetrating Radar: systems

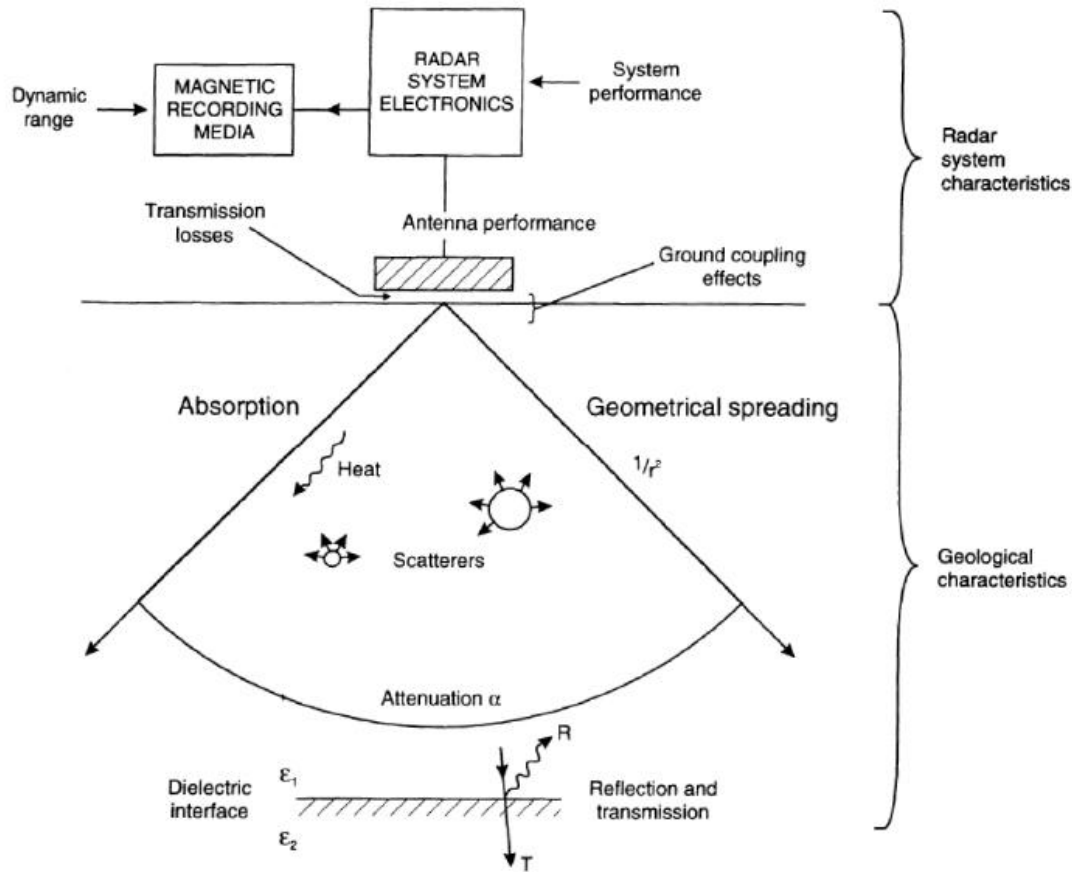

Reynolds, 1997

GPR are **Ultra-wide band (UWB) systems** transmitting an EM (short) wave into the ground by a **Transmitting antenna** and receiving reflection (and other events) from the subsurface by a **Receiving antenna**.

Ground Penetrating Radar: systems

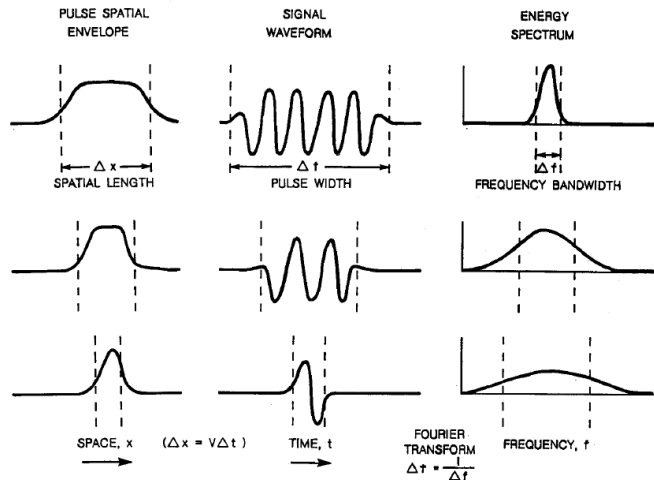

Davis, Annan, 1989

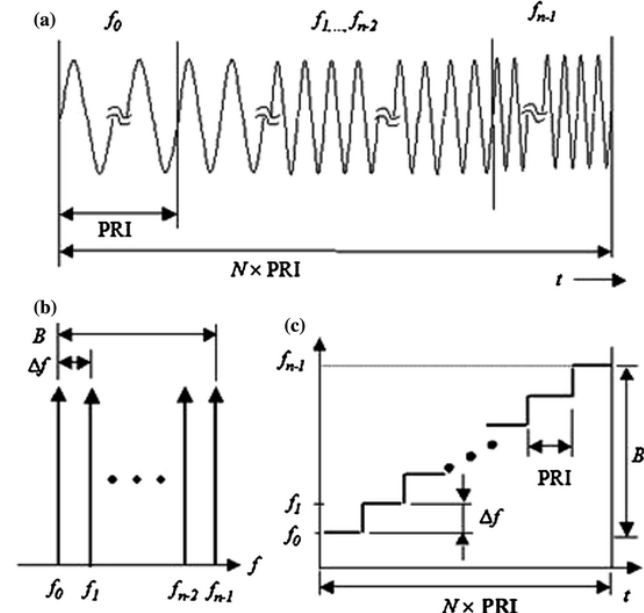

Nguyen & Park, 2016

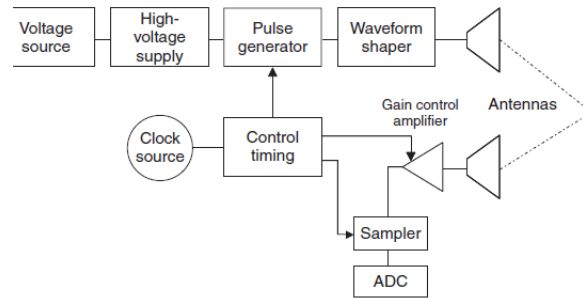

Impulse GPR system block diagram.

Most of GPR systems on the market are **Impulse radars**, using a short time transient wavelet radiated into the ground.

A valid alternative, recently widely exploited are **Stepped frequency systems**.

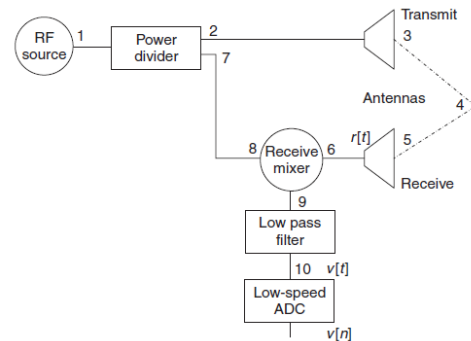

Simplified diagram of the stepped-frequency radar technique.

In this case, the transmitting frequency is stepped in linear increments over a fixed bandwidth, from a start frequency to a stop frequency. The received signal is mixed and sampled at each discrete frequency step. The digitized waveform is transformed into the time domain to create the synthesized pulse.

Ground Penetrating Radar: systems

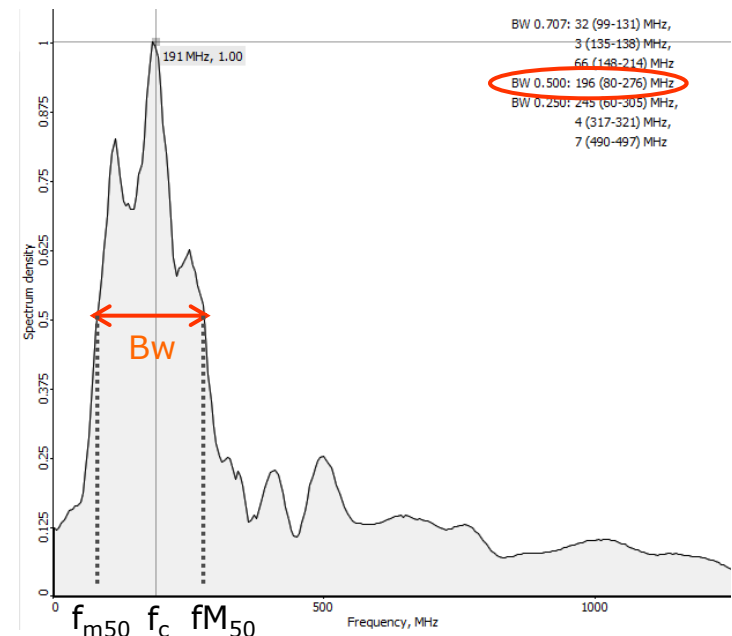
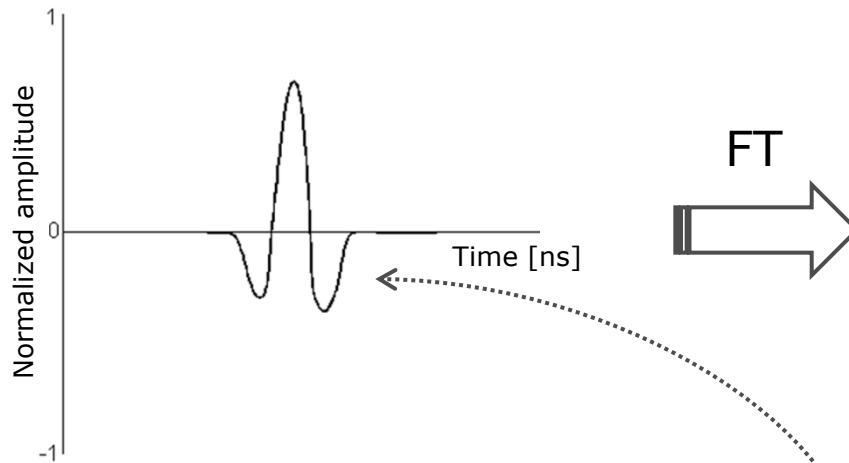

Typically, **impulsive GPR systems** emit a Ricker (Mexican hat!) wavelet, i.e. the second derivative of the Gaussian function, or similar transients with 2-5 phases.

Ultra wide band systems with the bandwidth almost equal (in air) to the central (nominal) frequency, i.e.:

$$BW = f_{M50} - f_{m50} \cong f_c$$

In the media the bandwidth is shortened and has a shift towards lower frequencies due to the low filtering effect of the media. This behavior is most relevant when the overall conductivity of the media is higher → LOWER RESOLUTION (and penetration depth).

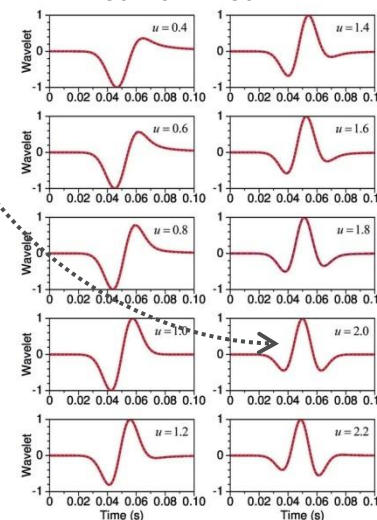

Generalized wavelets defined by fractional derivatives of a Gaussian function. Dashed curves are the approximations obtained by the timedomain fractional derivatives and are overlaid on solid curves which are the accurate waveforms obtained by a Fourier transform method. The fraction u varies from 0.4 to 2.2. When $u = 2.0$, the second derivative, it is the Ricker wavelet.

Wang, 2015

Ground Penetrating Radar: systems

GPR Dynamic Range refers to the capability of the system to handling both large signals from surface reflections and short-range targets, and also to detect small signals near the noise floor.

$$\text{Dynamic Range} = 20 \log \left(\frac{V_{max}}{V_{min}} \right)$$

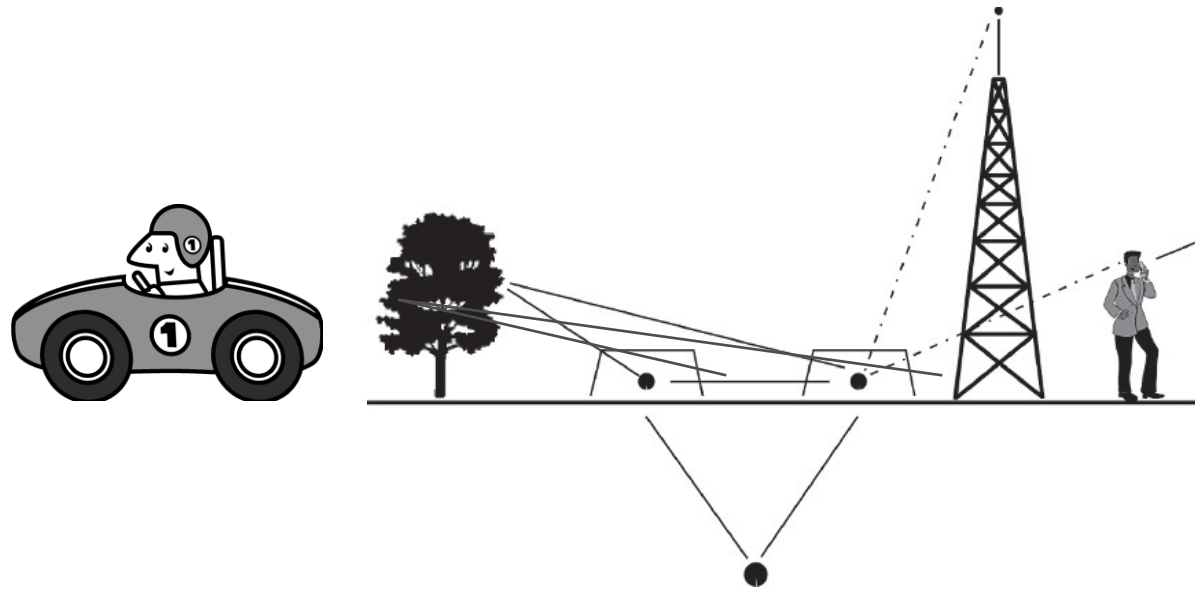

Lower S/N reduces the overall performances of GPR systems.

Beside random noises there are peculiar coherent "noises" related to the system itself like CLUTTER and RINGING.

CLUTTER encompasses all the unwanted echoes;

RINGING is due to reverberation between the antennas and within the same antenna (T or R)

Ground Penetrating Radar: antennas

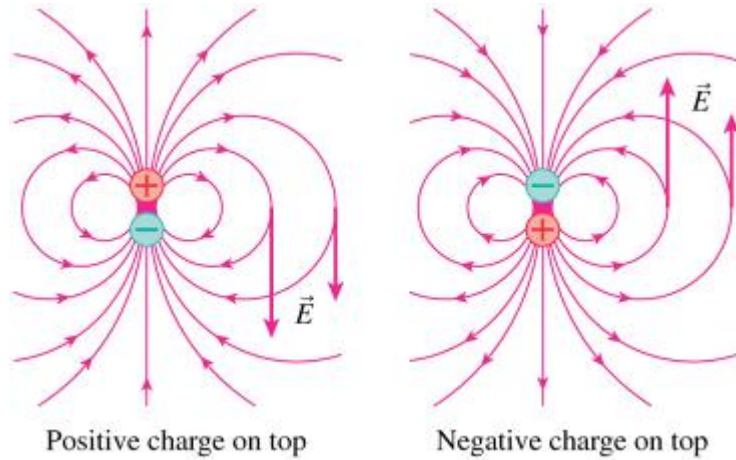

An oscillating voltage causes the dipole to oscillate.

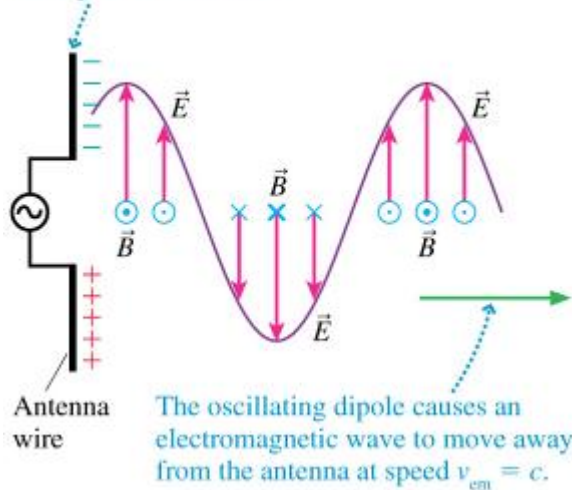

In the GPR case antennas are highly directive:

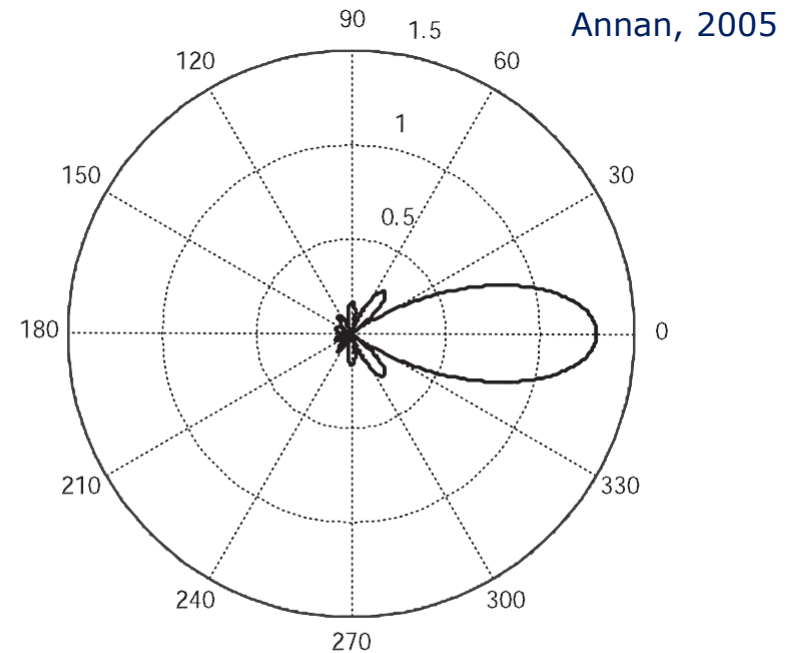

Figure 16. An example of antenna gain pattern. Similar plots can be created for directivity.

However the radiation pattern depends by the EM impedance of the top of the ground thus making difficult accurate forecasts about the actual performances of the antenna.

Ground Penetrating Radar: antennas

An **ANTENNA** is any device able to transmit and/or receive EM waves.

When dealing with antennas, usually the far-field approximation is considered → Plane EM waves.

In physical terms, the far-field represents the energy lost from the source as radiated electromagnetic energy.

The best way to view far-field radiation is to visualize the field on the surface of a large sphere which encloses the source. In theoretical terms, the far-field approximation becomes exact only when the radius of the sphere becomes infinite!

At any point on the sphere the electric (and magnetic) field is tangential to the surface. The field vector is decomposed into components that are in the $\hat{\vartheta}$ and $\hat{\varphi}$ unit vector directions; θ and ϕ are tangential to the sphere surface and perpendicular to one another. The field vector is then expressed as:

$$E = E_{\vartheta} \hat{\vartheta} + E_{\varphi} \hat{\varphi}$$

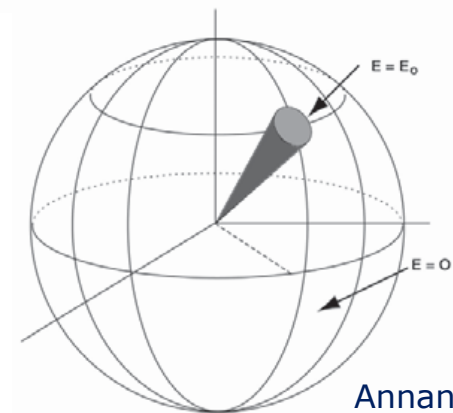
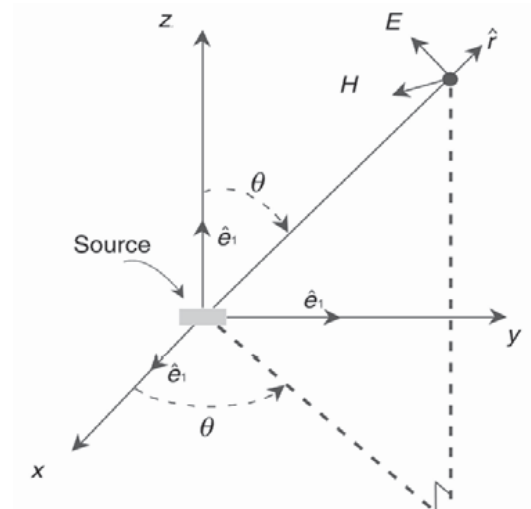

Annan, 2005

An **highly directional antenna** radiates energy in an electric field E_0 only in a small shaded area of the far-field sphere surface, while elsewhere the electric field is null.

Ground Penetrating Radar: antennas

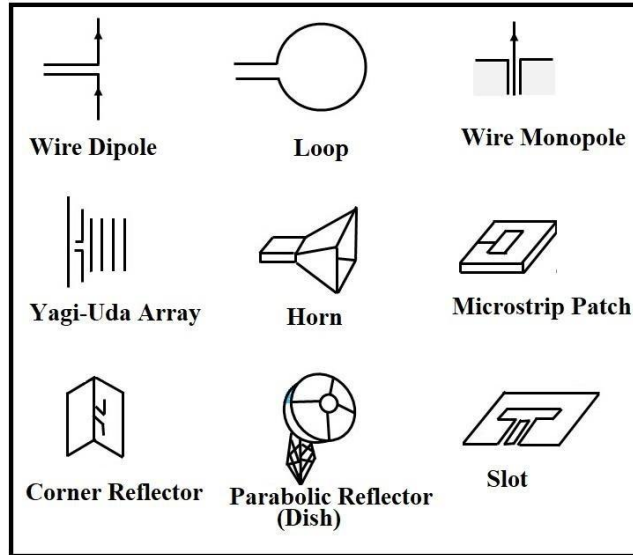

There are a plethora of antennas which can be use both as transmitting and/or receiving devices.

Some of the antennas must be in contact with the ground surface while other can operate at a certain elevation above it. Antennas are typically built for an EM impedance range and show low directivity and bad overall performances when used outside from it.

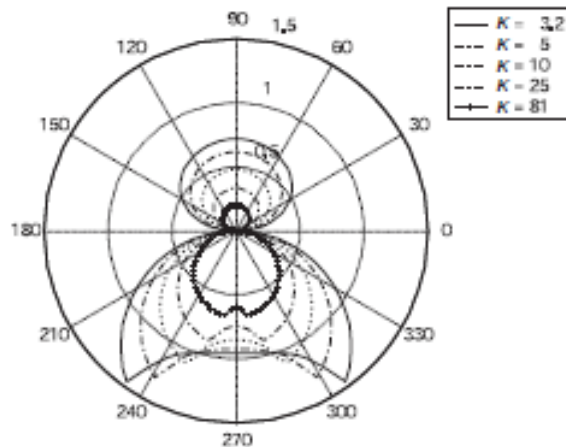

Figure 82. When the ground permittivity changes, the patterns change. The TE pattern is shown for permittivities ranging from ice (low) to water (high).

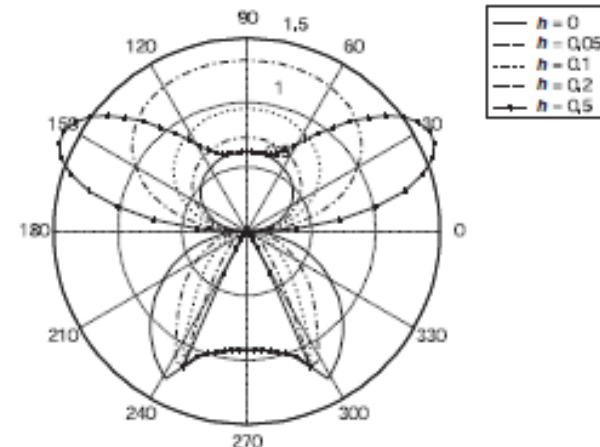

Figure 83. Antenna elevation also impacts directivity. The change in directivity is shown here as a function of height normalized against wavelength. MEMAG A.A. 2020-2021 **8**

Annan, 2005

Ground Penetrating Radar: antennas

There are Unshielded and Shielded antennas.

Shielding is used to achieve the following goals:

- maximize the energy on the path AA' i.e. from subsurface targets
- minimize the direct transmitter to receiver energy on path B
- minimize the energy emitted into the air and relative reflections as on path CC'
- minimize external electromagnetic noises as indicated by signals D

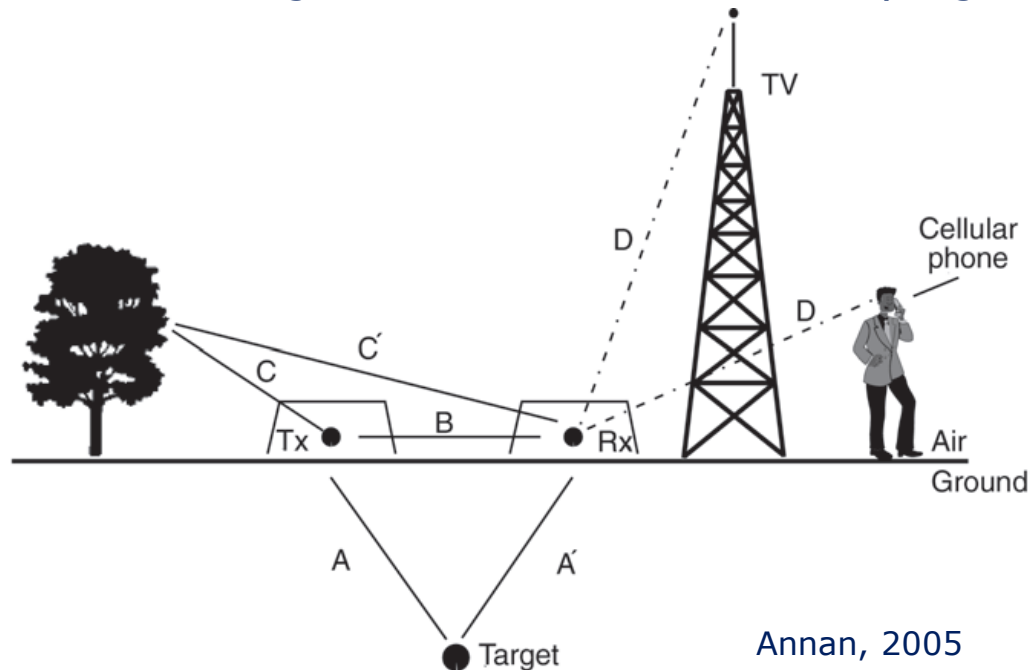

Antenna shielding requires a structure that has an important electromagnetic response → shielding must be properly designed and implemented.

Ground Penetrating Radar: antennas

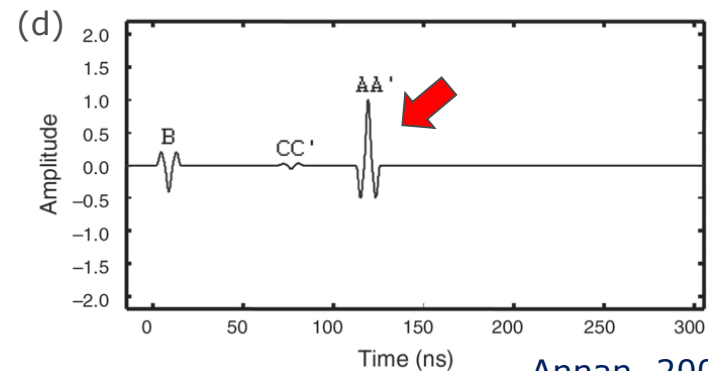
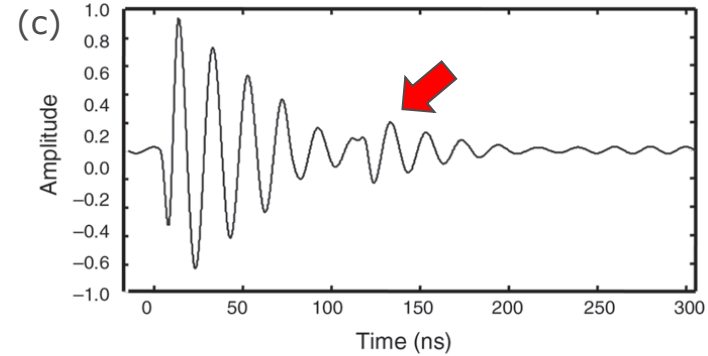
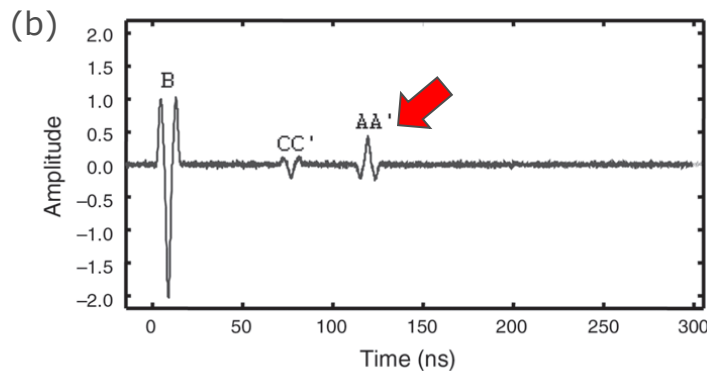
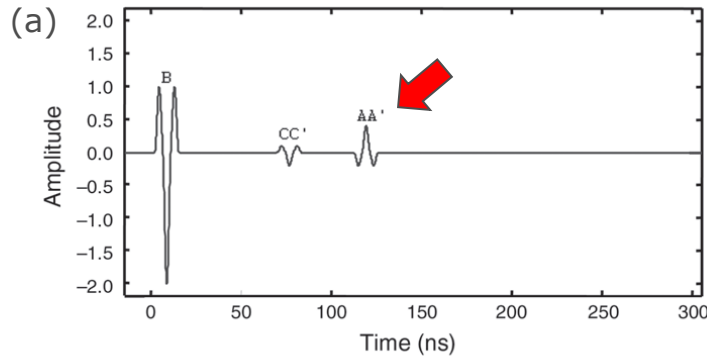

Annan, 2005

(a) Unshielded noise free response, (b) typical response with external noise, (c) transient response when shielding is improperly implemented, (d) results with a practical well-implemented shielding.

Shielding is especially helpful when GPR is used in urban areas, but there are some drawbacks:

- Overall weight and size are larger
- offset between the antennas is fixed
- only standard acquisitions can be implemented

Ground Penetrating Radar: antennas



Shielded **Unshielded**



High
freq.

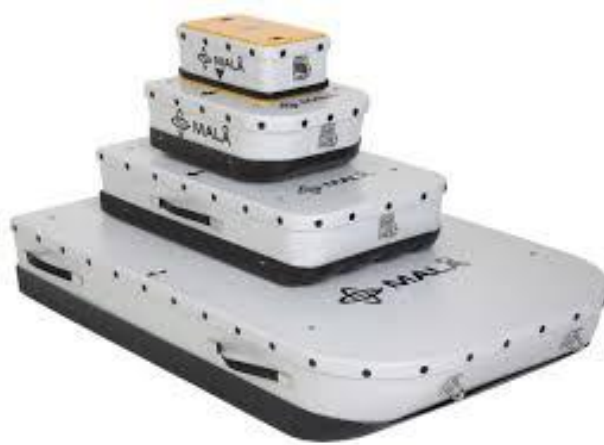

Low
freq.

Antenna dimensions are inversely proportional to the nominal frequency → Low frequency shielded antennas are wider in size and heavier than high frequency ones, thus making them logistically complex to use e.g. on rough terrains or where obstacles are present.

Two are the main reasons for that:

- 1) The far field approximation is valid at larger distances (offsets) for low freq. antennas → minimum offset cannot be as short as desired.
- 2) To emit low frequency EM components the antenna must be large in size, with minor dependence from the antenna type.



Ground Penetrating Radar: antennas and surveys



Ground Penetrating Radar: multi-array antennas

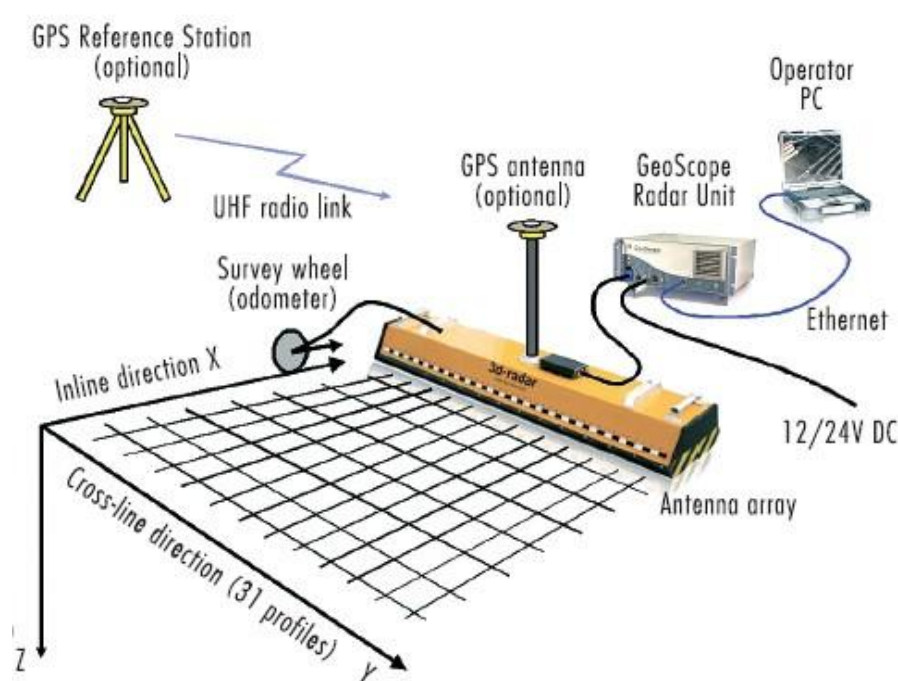

In the last decade new **multi-array GPR systems** have been implemented. Several acquisition geometries are possible (series of common offset profiles, multi offset profiles, profiles with different radiation patterns, multi azimuth profiles).

PROS:

- Shorter acquisition time → larger surveyed areas
- Higher spatial coverage (especially x-line) → data redundancy

CONS:

- Higher costs
- Lower portability and strong logistical constraints

Ground Penetrating Radar: resolution

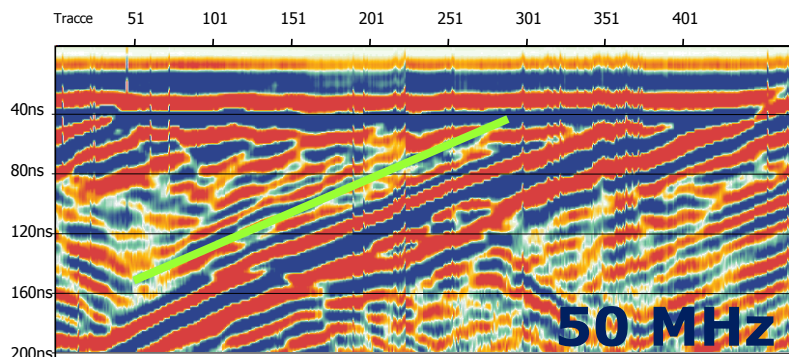
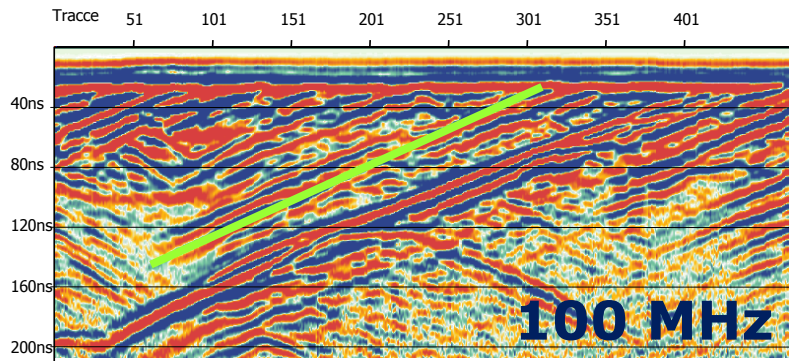
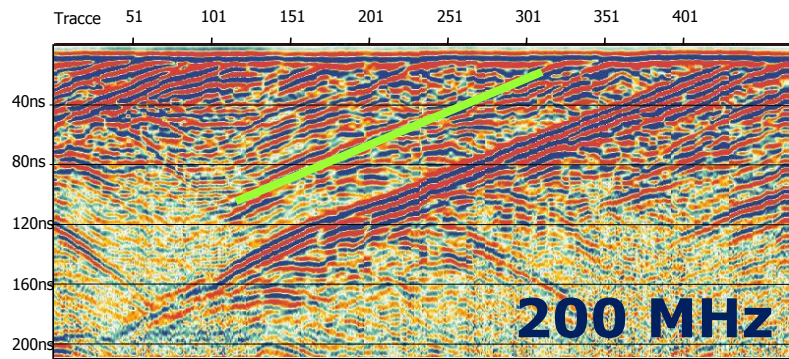

Vertical resolution is strictly proportional to the antenna frequency.

Maximum achievable vertical resolution is equal to $\lambda/4$ [m] (considering λ related to f_c).

This relation defines the "optical resolution" limit and is strictly valid only for monochromatic waves.

A more useful empirical relation, helpful in defining the required minimum central frequency f_c able to resolve targets separation equal to Δz [m] is:

$$f_c^R > \frac{75}{\Delta z \sqrt{\epsilon_r}} \text{ [MHz]}$$

Scattering in GPR systems refers to the signals returned from heterogeneity in soils and rock. The radar response of small scale features (e.g. fine-scale bedding, cracks and joints, laminations,...) increases rapidly as radar frequency increases, in turn increasing overall propagation attenuation. Scattering, as well as coherent and random noise **DECREASE** the achievable resolution making impossible to reach the optical resolution limit.

A much more common approximation is $\lambda/3$ [m].

Ground Penetrating Radar: resolution

Vertical resolution

In order to “see” into the ground to depth (i.e. to image the subsurface targets), the amount of energy scattered should be minimized. To achieve this, the signal wavelength should be much longer (nominally by a factor of ten) than the typical heterogeneity or scatterers dimension ΔL in the host environment. The scattering center frequency constraint takes the form:

$$f_c^S < \frac{30}{\Delta L \sqrt{\epsilon_r}} \text{ [MHz]}$$

If the survey problem has been properly posed, then the selected antenna central frequency f_c should be:

$$f_c^R < f_c < f_c^S$$

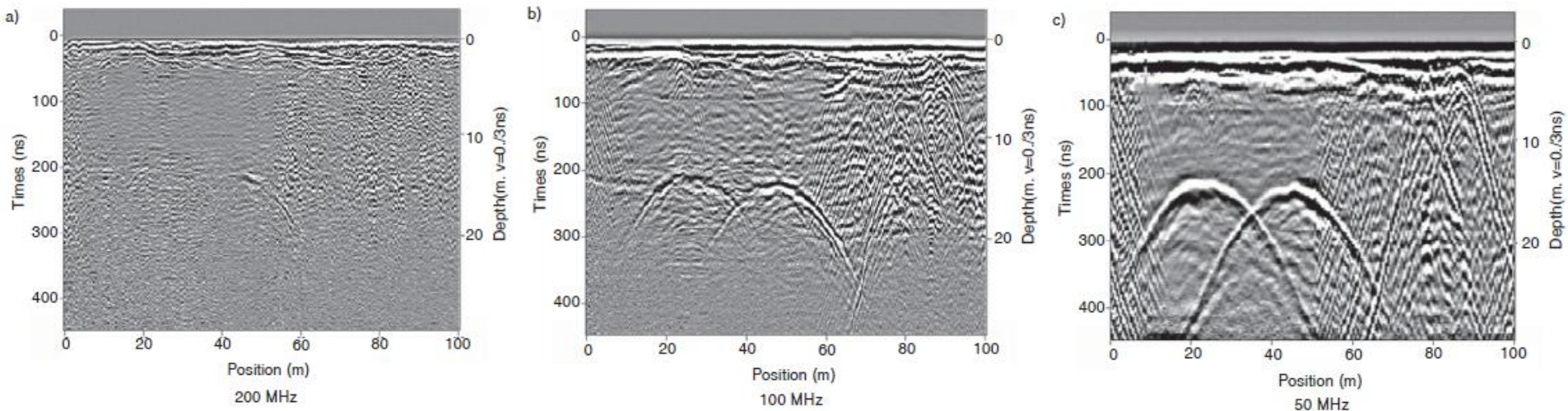

Too high attenuation and scattering

Too high scattering on the right

adequate penetration depth with low scattering

Ground Penetrating Radar: lateral resolution

Lateral resolution depends by combined frequencies, wavelengths (and so EM velocities, being $v=f\lambda$) depth of the targets and trace sampling interval.

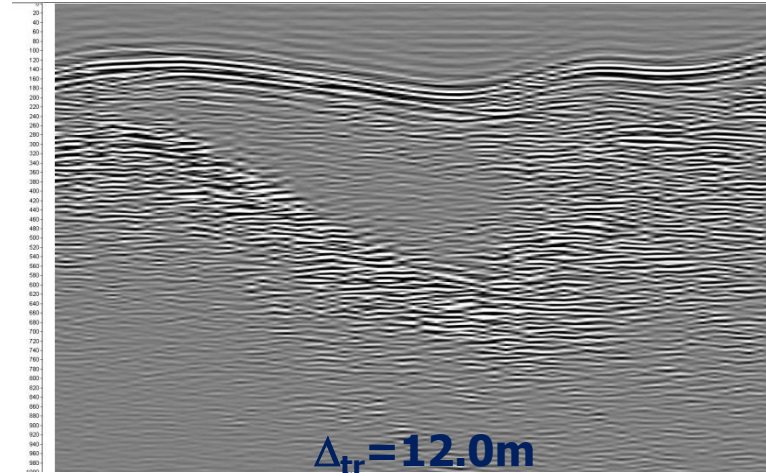
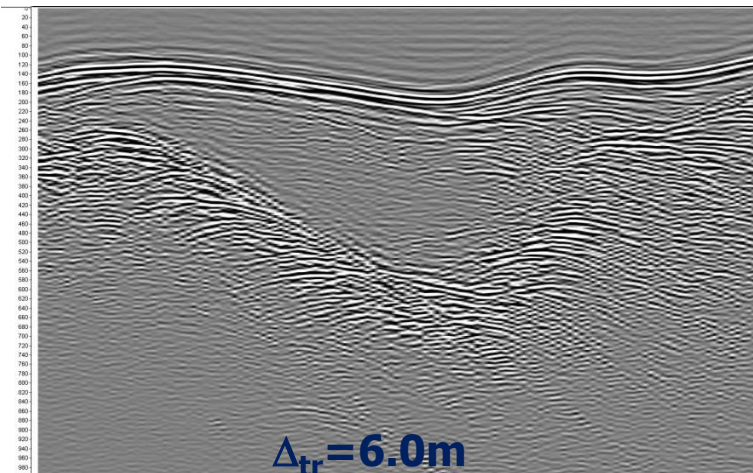
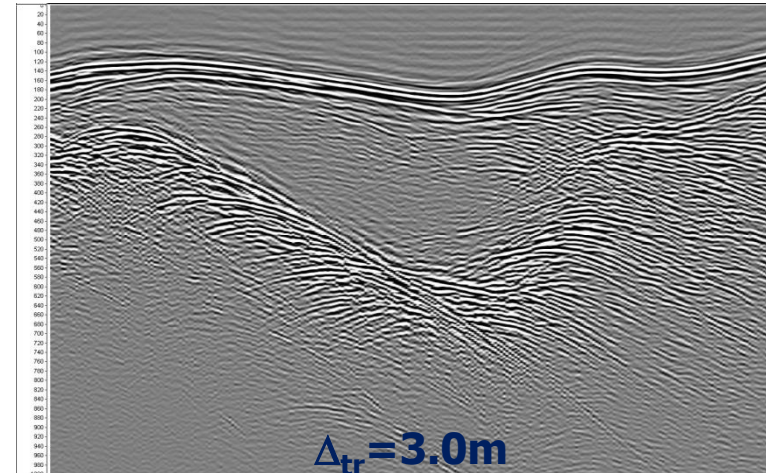
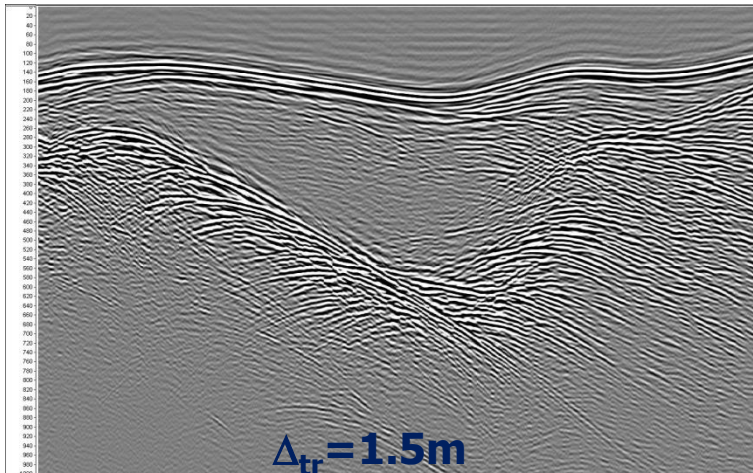

Notice that problems (aliasing) occur for high dip reflectors and diffractions

Ground Penetrating Radar: lateral resolution

The **lateral resolution** is the minimum lateral distance between two reflecting points for which they are still recognizable as separated.

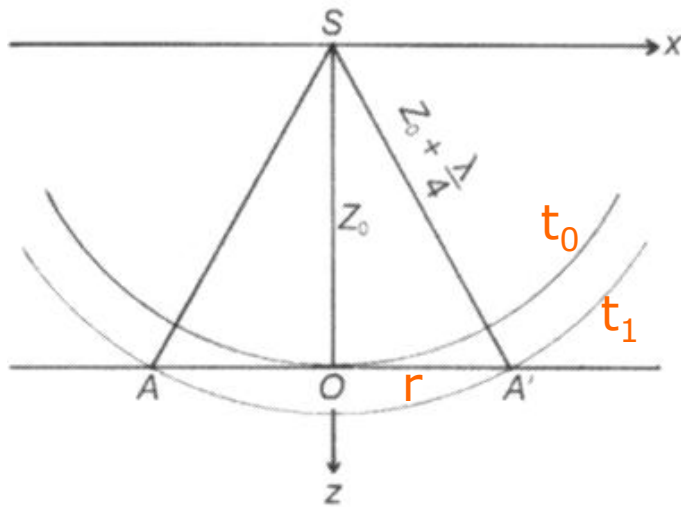

$$r = \sqrt{\left(z_0 + \frac{\lambda}{4}\right)^2 - z_0^2}$$

$$r = \sqrt{z_0^2 + \frac{\lambda^2}{16} + 2 \frac{z_0 \lambda}{4} - z_0^2}$$

$$r = \sqrt{\frac{\lambda^2}{16} + \frac{z_0 \lambda}{2}}$$

And considering that $\lambda \ll z_0$

$$r \cong \sqrt{\frac{z_0 \lambda}{2}}$$

All the energy arriving in the time interval $t_1 - t_0$ has constructing interference, because: $\rightarrow t_1 - t_0 = T/2$

$$t_0 = \frac{2z_0}{v} \quad t_1 = \frac{2(z_0 + \lambda/4)}{v}$$

Since $v = f\lambda$ and $z_0 = \frac{t_0 v}{2}$

$$r \cong \sqrt{\frac{z_0 \lambda}{2}}$$

$$r \cong \sqrt{\frac{z_0 v}{2f}}$$

$$r \cong \sqrt{\frac{t_0 v \cdot v}{2 \cdot 2f}}$$



$$r \cong \frac{v}{2} \sqrt{\frac{t_0}{f}}$$



FIRST FRESNEL ZONE \rightarrow

$$R_{LAT} \propto \frac{1}{r}$$

Ground Penetrating Radar: data acquisition

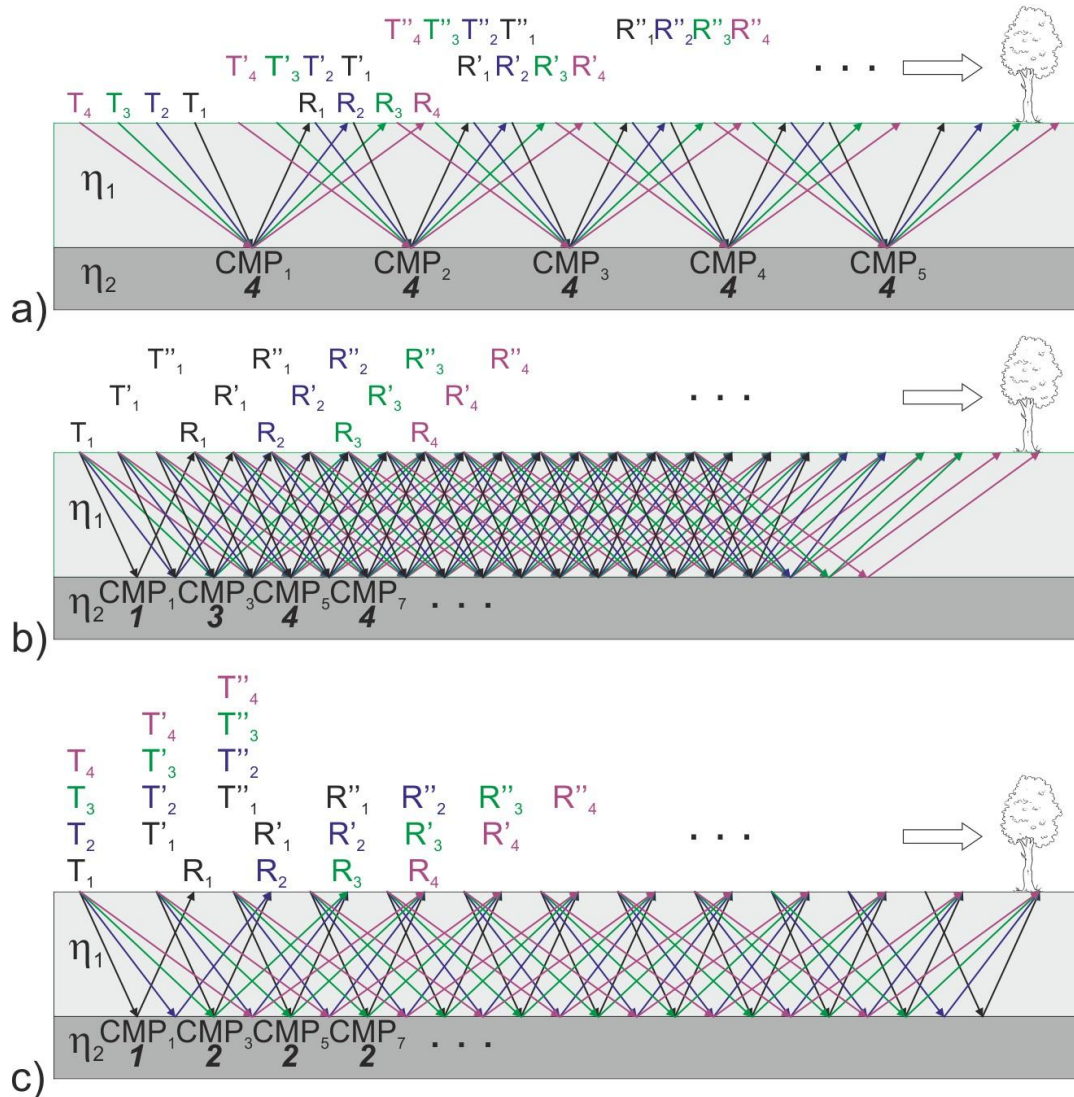

1) MULTIPLE CMP gathers
 Constant folding $\rightarrow F = N(\text{offset})$
 Maximum location accuracy
 Longest acquisition time

2) MULTIPLE Common shot (or receiver) gathers
 Variable folding \rightarrow
 $F_{max} = N\Delta_{off}/2\Delta_{SH}$
 Intermediate location accuracy
 Intermediate acquisition time

3) MULTIPLE Common offset profiles
 Variable folding \rightarrow
 $\Delta_{SH} = \Delta_{off}/2$
 Minimum location accuracy
 Shorter acquisition time

Ground Penetrating Radar: data acquisition

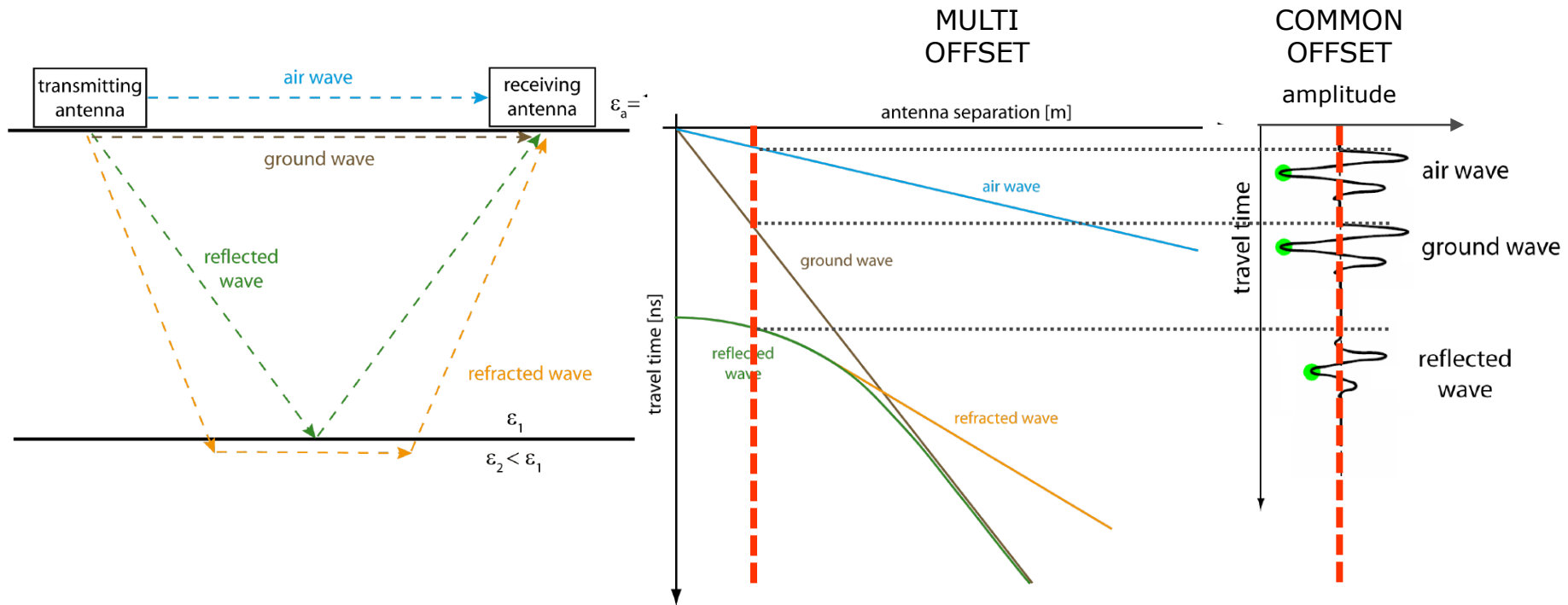

Reciprocal connections between the GPR experiment and the different EM events generated and registered in both **MULTI-OFFSET** and **COMMON-OFFSET** records.

Possible interferences can prevent single events recognition on CO data, while all the recorded wave types can be easily identified on MO data.

Ground Penetrating Radar: data acquisition

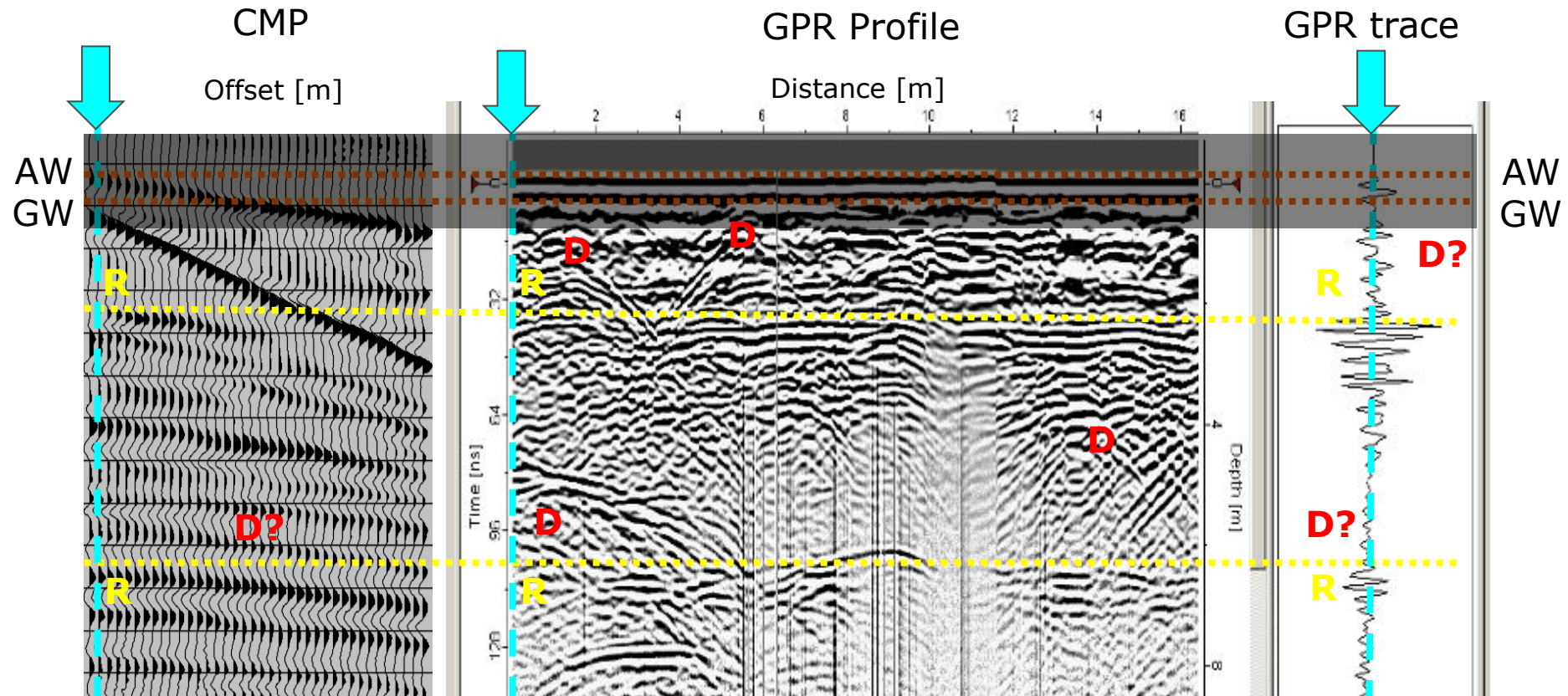

On a single trace it is very difficult (when possible) to recognize reflections and diffractions. They are easier to highlight on GPR profiles, but the most effective way to recognize different events is by exploiting MULTI FOLD data (CMP analysis).

Ground Penetrating Radar: data acquisition

Special survey geometries, exploiting peculiar characteristics of the antennas polarization and/or logistical constraints:

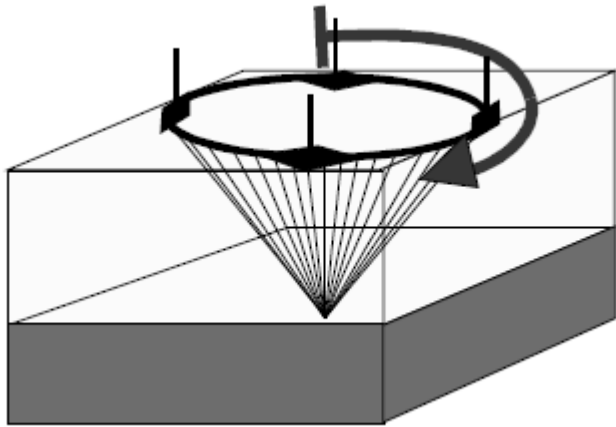

Polarimetric measurements

E a) H	CO-POLARIZED		CROSS-POLARIZED
	END FIRE	BROADSIDE	
TM	b)	c)	d)
TE	e)	f)	g)

Measurements with different antennas geometries.

They can be:

- 1) *co- or cross-polarized;*
- 2) they can have the electric field vector oscillating along (*TM mode*) or across (*TE mode*) to the survey direction;
- 3) they can be oriented with their endpoints toward each other (*End fire configuration*) or with the broadsides toward each other (*Broad-side configuration*).

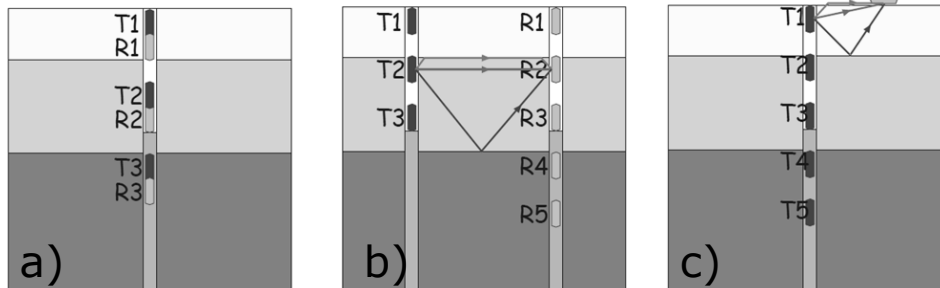

Borehole measurements

- a) reflection;
- b) tomography;
- c) Vertical Radar Profiling



Questions?