

# Sommario

- trasformazione sulla variabile tempo
- proprietà dei segnali
- segnali elementari
  - tempo continuo
  - tempo discreto
- energia e potenza

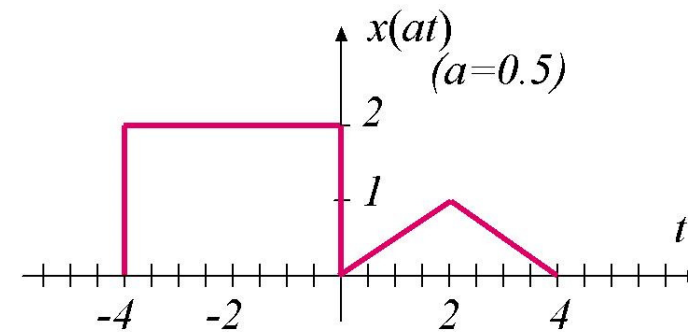

# Trasformazioni di variabile

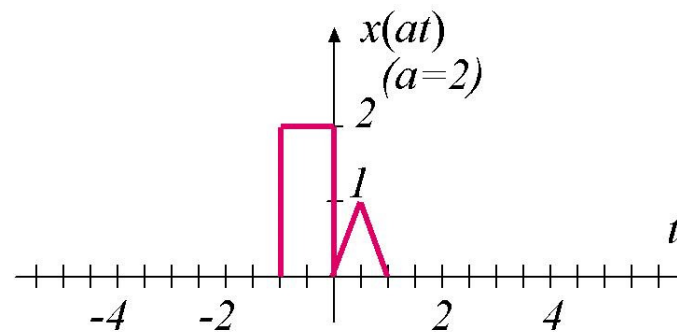
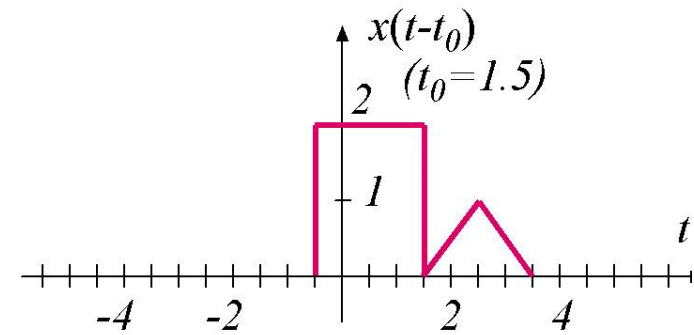
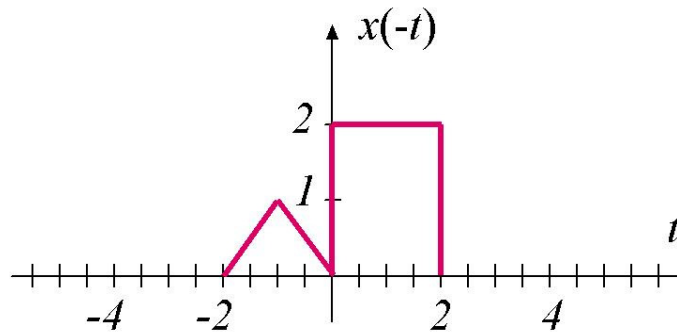
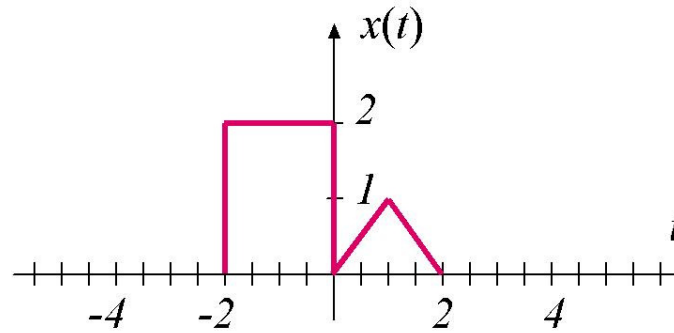

# Parità

Un segnale è pari se:

$$x(t) = x(-t) \quad \forall t$$
$$x[n] = x[-n] \quad \forall n$$

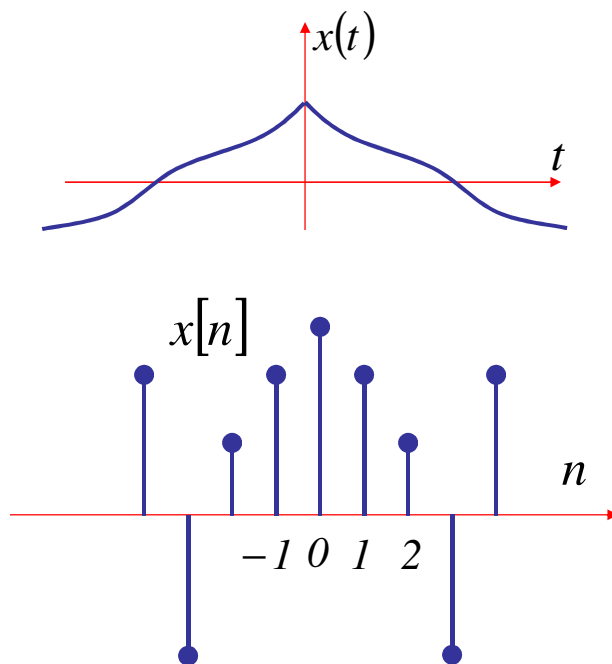

Un segnale è dispari se:

$$x(t) = -x(-t) \quad \forall t$$
$$x[n] = -x[-n] \quad \forall n$$

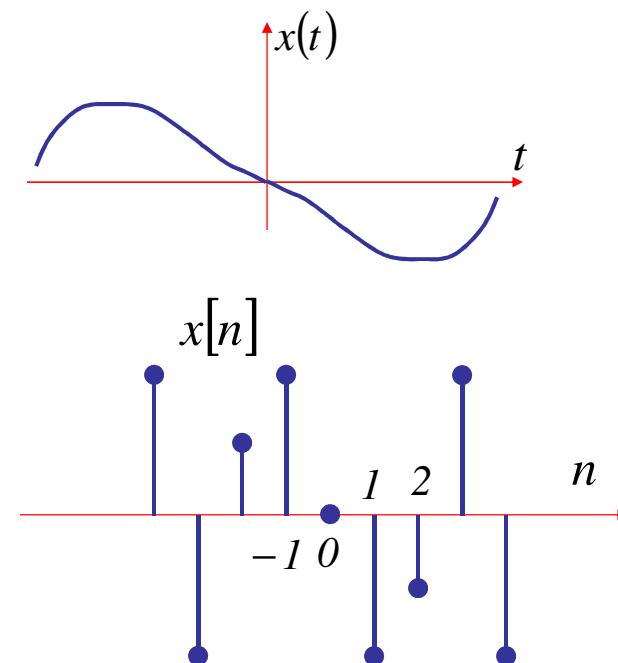

## Parte pari – Parte dispari

Ogni segnale può essere scomposto nella somma di un **segnale pari e uno dispari**

$$x(t) = x_p(t) + x_d(t)$$

$$x_p(t) = \frac{x(t) + x(-t)}{2}$$

$$x_d(t) = \frac{x(t) - x(-t)}{2}$$

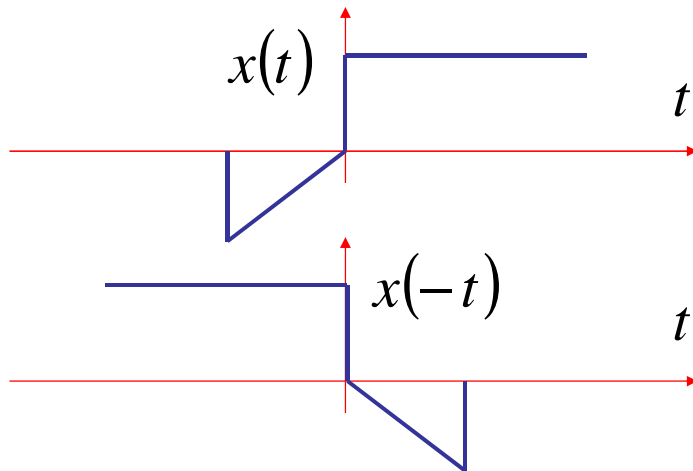

La scomposizione è **unica**

$$x[n] = x_p[n] + x_d[n]$$

$$x_p[n] = \frac{x[n] + x[-n]}{2}$$

$$x_d[n] = \frac{x[n] - x[-n]}{2}$$

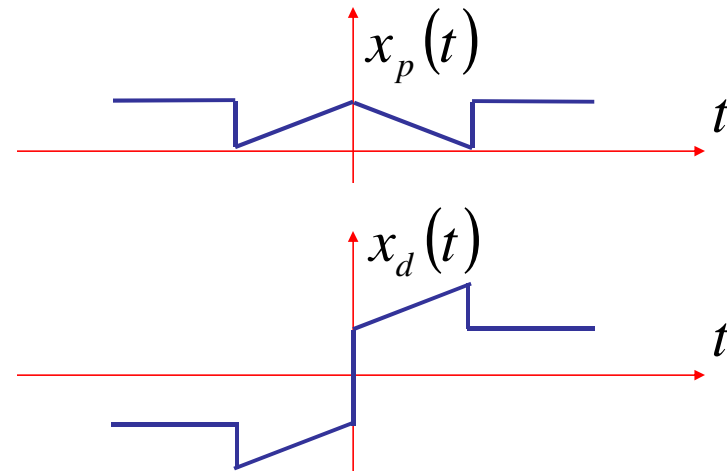

# Periodicità

Un segnale  $x(t)$  è **periodico** se esiste un numero reale  $T \neq 0$  tale che:

$$x(t + T) = x(t) \quad \forall t$$

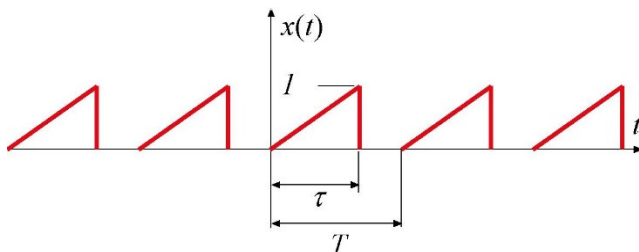

**Periodo:**

Il più piccolo valore di  $T$  per cui

$$x(t + T) = x(t) \quad \forall t$$

Un segnale  $x[n]$  è **periodico** se esiste un numero intero  $N \neq 0$  tale che:

$$x[n + N] = x[n] \quad \forall n$$

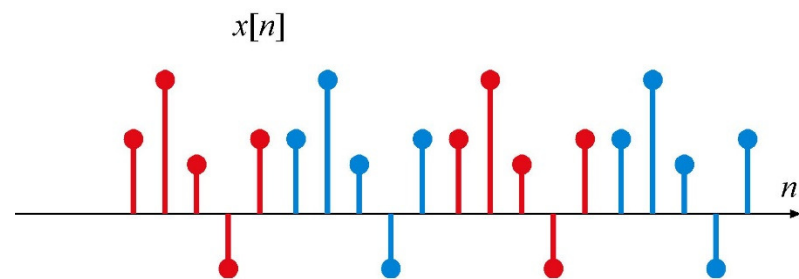

**Periodo:**

Il più piccolo valore di  $N$  per cui

$$x[n + N] = x[n] \quad \forall n$$



# Segnali elementari tempo-continuo

Esponenziale complesso:

$$x(t) = Ce^{at}$$

$C$  e  $a$  complessi

Casi particolari:

$C$  e  $a$  reali

*esponenziale reale*

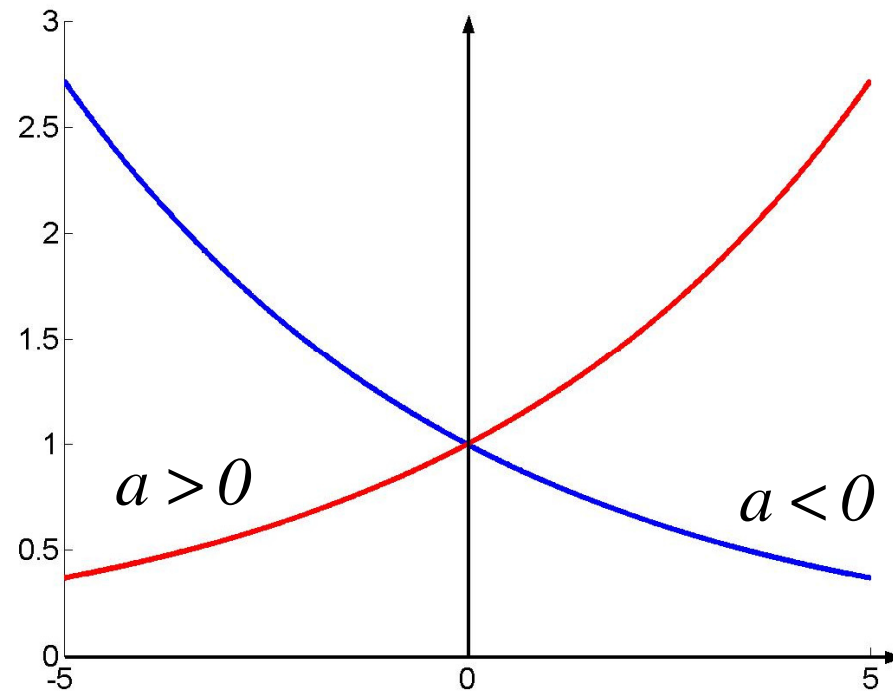

# Segnali elementari tempo-continuo

$C$  reale

$a$  immaginario  $= j\omega_0 = j2\pi f_0$

$$x(t) = e^{j\omega_0 t}$$

Segnale periodico di periodo  $T = \frac{2\pi}{\omega_0} = \frac{1}{f_0}$

## Formule di Eulero

$$e^{j\omega_0 t} = \cos\omega_0 t + j \sin\omega_0 t$$

$$e^{-j\omega_0 t} = \cos\omega_0 t - j \sin\omega_0 t$$

$$\cos\omega_0 t = \frac{e^{j\omega_0 t} + e^{-j\omega_0 t}}{2}$$

$$\sin\omega_0 t = \frac{e^{j\omega_0 t} - e^{-j\omega_0 t}}{2j}$$



# Segnali elementari tempo-continuo

Proprietà del segnale  $x(t) = e^{j\omega_0 t}$

**I segnali**

$$\phi_k(t) = e^{jk\omega_0 t}$$

con  $k$  intero sono in relazione armonica tra loro

$$\phi_k(t) = e^{jk\omega_0 t} \Rightarrow \text{periodico di periodo } \frac{2\pi}{k\omega_0} = \frac{1}{kf_0}$$

$$\text{ma anche di periodo } \frac{2\pi}{\omega_0} = \frac{1}{f_0}$$

**Pertanto:**

$$y(t) = \sum_{k=-\infty}^{+\infty} C_k e^{jk\omega_0 t} \quad \text{segnale periodico di periodo } T = \frac{2\pi}{\omega_0} = \frac{1}{f_0}$$





# Segnali elementari tempo-continuo

## Esponenziale complesso: caso generale

$C$  complesso  $\Rightarrow C = |C|e^{j\theta}$

$a$  complesso  $\Rightarrow a = \sigma + j\omega_0$

$$Ce^{at} = |C|e^{\sigma t} \cos(\omega_0 t + \theta) + j|C|e^{\sigma t} \sin(\omega_0 t + \theta)$$

Tipico andamento della parte reale o immaginaria

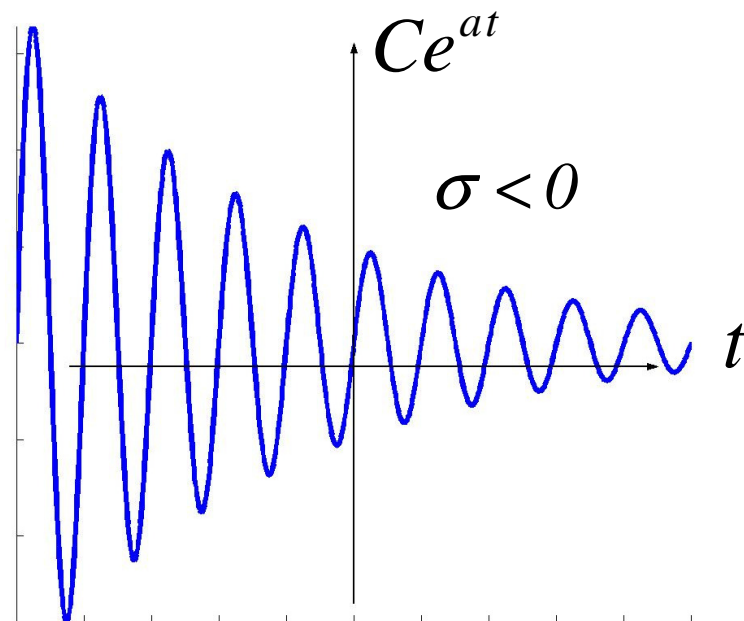

# Segnali elementari tempo-continuo

**Gradino unitario**

$$u(t) = \begin{cases} 0, & t < 0 \\ 1, & t > 0 \end{cases}$$

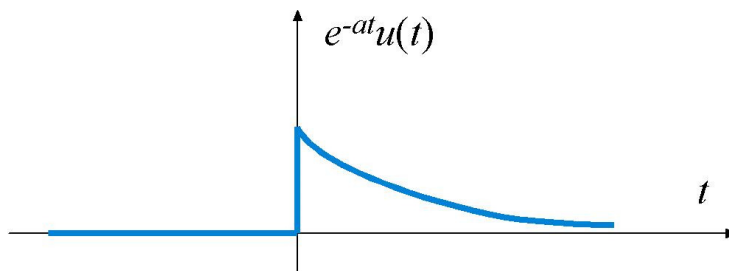
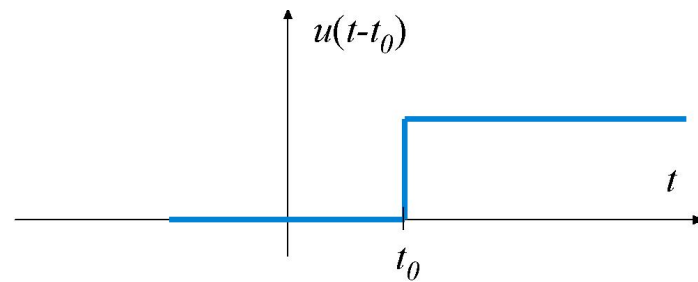
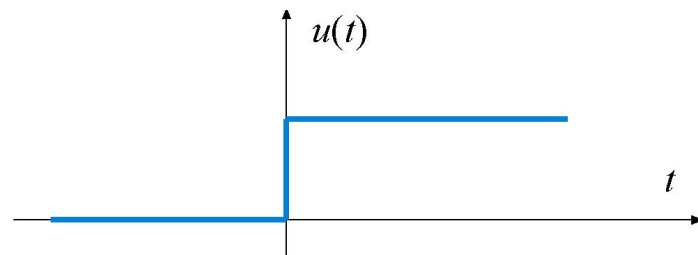

altre definizioni

$$u(t) = \begin{cases} 0, & t \leq 0 \\ 1, & t > 0 \end{cases}$$

$$u(t) = \begin{cases} 0, & t < 0 \\ 1, & t \geq 0 \end{cases}$$

$$u(t) = \begin{cases} 0, & t < 0 \\ \frac{1}{2}, & t = 0 \\ 1, & t > 0 \end{cases}$$

Tipico impiego della  
funzione gradino



# Segnali elementari tempo-continuo

## Impulso unitario ( $\delta$ - Dirac)

$$x(t) = \delta(t)$$

“**funzione**” che opera in maniera particolare sotto il segno di integrazione:

$$\int_{-\infty}^{+\infty} \delta(t) dt = \int_{-\varepsilon}^{+\varepsilon} \delta(t) dt = \int_a^a \delta(t) dt = 1$$

$(0 \in a)$

$$\int_{-\infty}^{+\infty} f(t) \delta(t) dt = f(0)$$

$$\int_{-\infty}^{+\infty} f(t) \delta(t - t_0) dt = f(t_0) \quad \int_{-\infty}^{+\infty} f(t) \delta^n(t - t_0) dt = f^n(t_0)$$

$$f(t) \delta(t) = f(0) \delta(t) \quad f(t) \delta(t - t_0) = f(t_0) \delta(t - t_0)$$



## Segnali elementari tempo-continuo

Definizione della funzione  $\delta(t)$  come limite di una successione di funzioni:

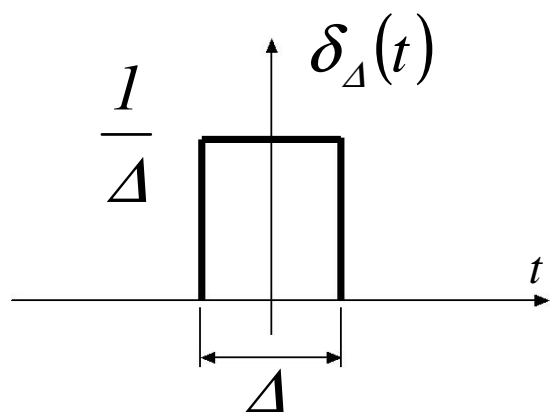

$$\int_{-\infty}^{+\infty} \delta_{\Delta}(t) dt = 1 \quad \forall \Delta$$
$$\lim_{\Delta \rightarrow 0} \delta_{\Delta}(t) = \delta(t)$$

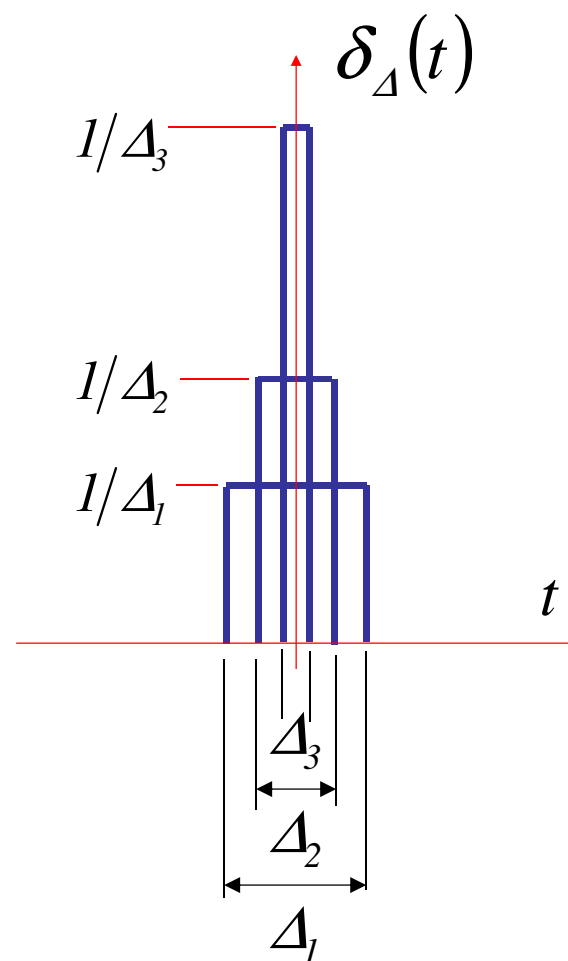

# Segnali elementari tempo-continuo

- Un impulso realistico

$$\delta_a(t) = \frac{\sin(a\pi t)}{\pi t}$$

$$\delta'_a(t) = \frac{a\pi t \cos(a\pi t) - \sin(a\pi t)}{\pi^2 t^2}$$

$$\delta''_a(t) = \frac{(2 - (a\pi t)^2) \sin(a\pi t) - 2a\pi t \cos(a\pi t)}{\pi^3 t^3}$$

$$\int_{-\infty}^{+\infty} \delta_a(t) dt = 1 \quad \forall a$$
$$\lim_{a \rightarrow \infty} \delta_a(t) = \delta(t)$$

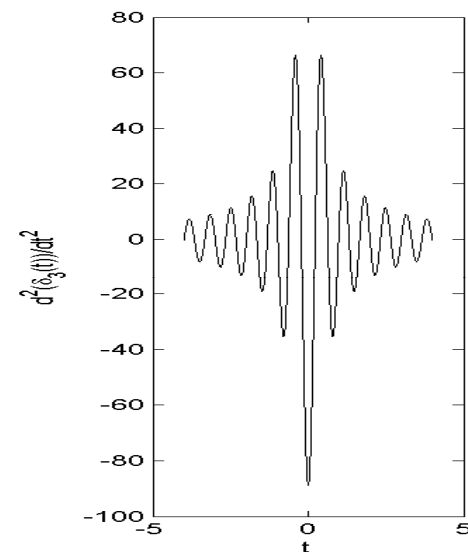
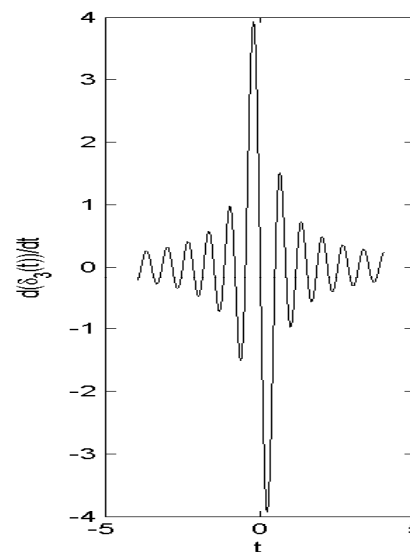
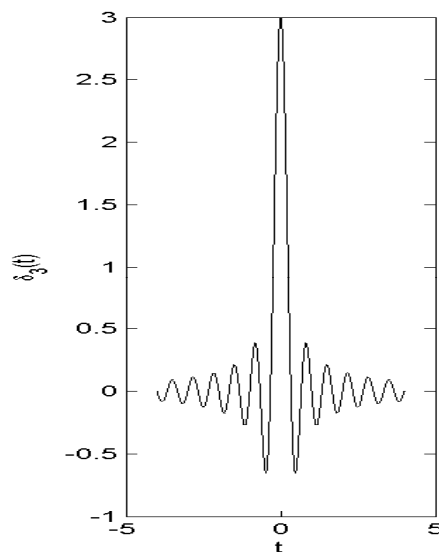

## Segnali elementari tempo-continuo

Relazioni tra  $u(t)$  e  $\delta(t)$

$$u(t) = \int_{-\infty}^t \delta(\tau) d\tau$$

$$\delta(t) = \frac{du(t)}{dt}$$

$$\lim_{\Delta \rightarrow 0} u_{\Delta}(t) = u(t)$$

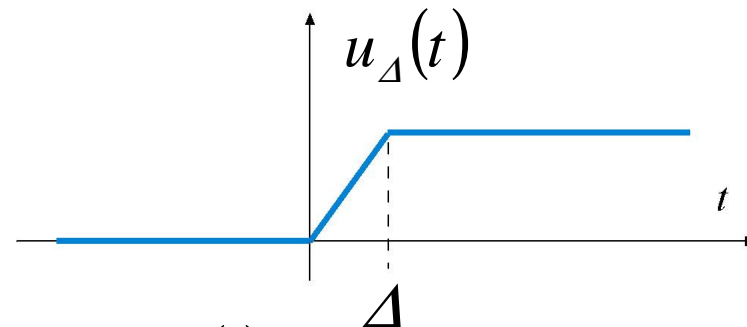

$$\delta_{\Delta}(t) = \frac{du_{\Delta}(t)}{dt}$$

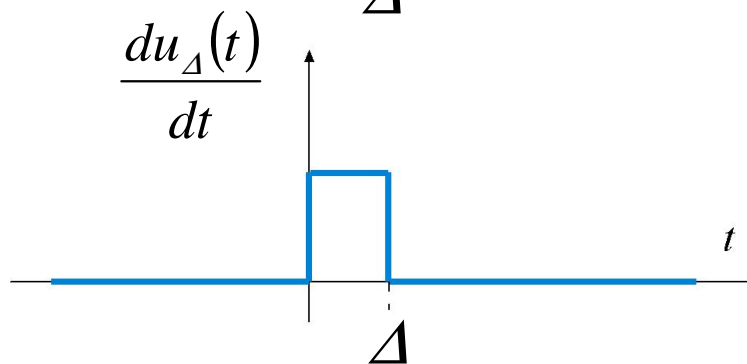

$$\lim_{\Delta \rightarrow 0} \delta_{\Delta}(t) = \delta(t)$$



# Segnali elementari tempo-discreto

**Gradino unitario**  $u[n] = \begin{cases} 0, & n < 0 \\ 1, & n \geq 0 \end{cases}$

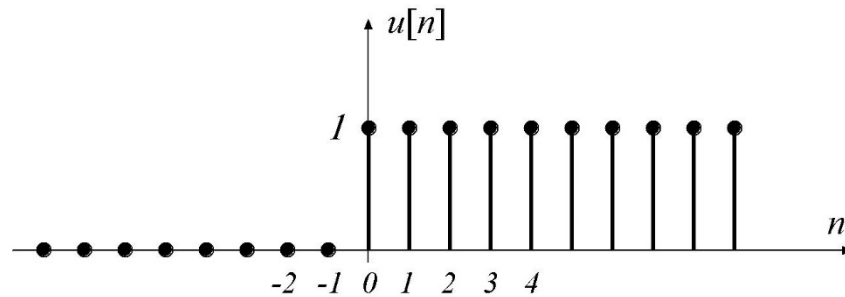

**Impulso unitario**  $\delta[n] = \begin{cases} 0, & n \neq 0 \\ 1, & n = 0 \end{cases}$

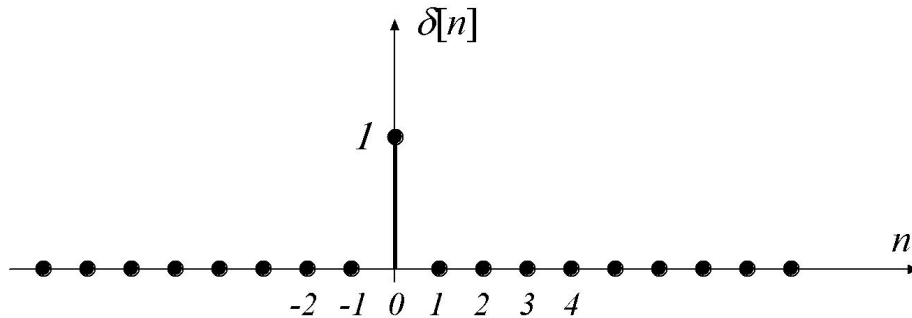

Relazioni tra

$\delta[n]$  e  $u[n]$

$$\delta[n] = u[n] - u[n-1]$$

$$u[n] = \sum_{k=-\infty}^n \delta[k]$$

$$x[n]\delta[n] = x[0]\delta[n]$$



# Segnali elementari tempo-discreto

## Esponenziale complesso

Forma generale:

$$\left\{ \begin{array}{l} x[n] = z^n \quad z \text{ complesso} \\ z = |z|e^{j\omega} \end{array} \right.$$

## $z$ reale

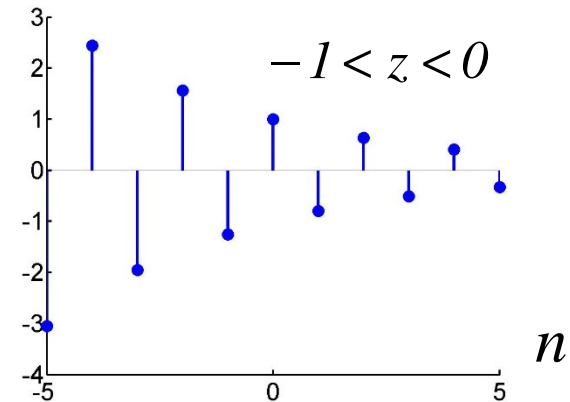
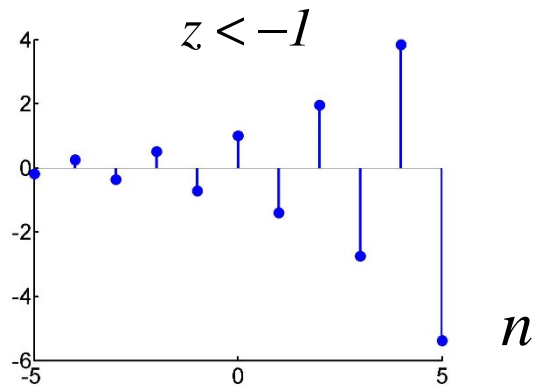
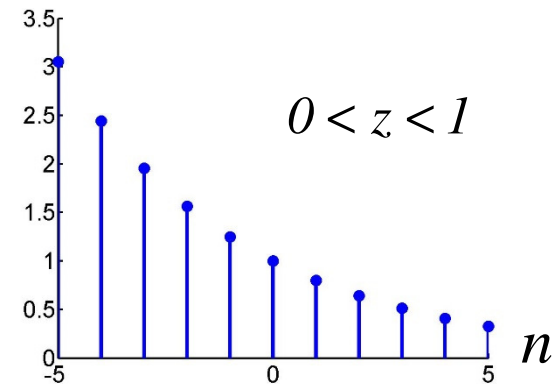
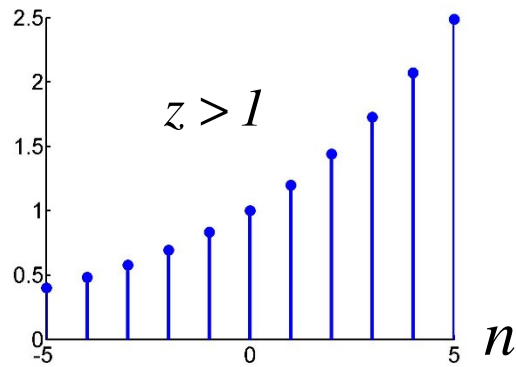



## Segnali elementari tempo-discreto

$$|z| = 1$$
$$z = e^{j\omega_0}$$

$$x[n] = z^n = e^{j\omega_0 n}$$

Proprietà:

- a) Valori  $\omega_0$  che differiscono per un multiplo di  $2\pi$  danno luogo alla medesima funzione

$$e^{j(\omega_0 + 2k\pi)n} = e^{j\omega_0 n} e^{j2k\pi n} = e^{j\omega_0 n} = 1$$

I valori di  $\omega_0$  su un intervallo lungo  $2\pi$  (es.:  $0, 2\pi$ )

generano tutte le possibili funzioni  $e^{j\omega_0 n}$  distinte



## Segnali elementari tempo-discreto

b) In generale non esiste un intero  $N$  tale che:  $e^{j\omega_0 n} = e^{j\omega_0(n+N)}$   
In generale  $e^{j\omega_0 n}$  non è periodica

$$e^{j\omega_0 n} \text{ è periodica soltanto se } \omega_0 = m \frac{2\pi}{N}$$

In questo caso:

$$e^{j\omega_0 n} = e^{jmn \frac{2\pi}{N}}$$
$$e^{j\omega_0(n+N)} = e^{jmn \frac{2\pi}{N}} e^{jm2\pi} = e^{j\omega_0 n} = 1$$

→ Periodica di periodo  $N$



# Segnali elementari tempo-discreto

## Esempio

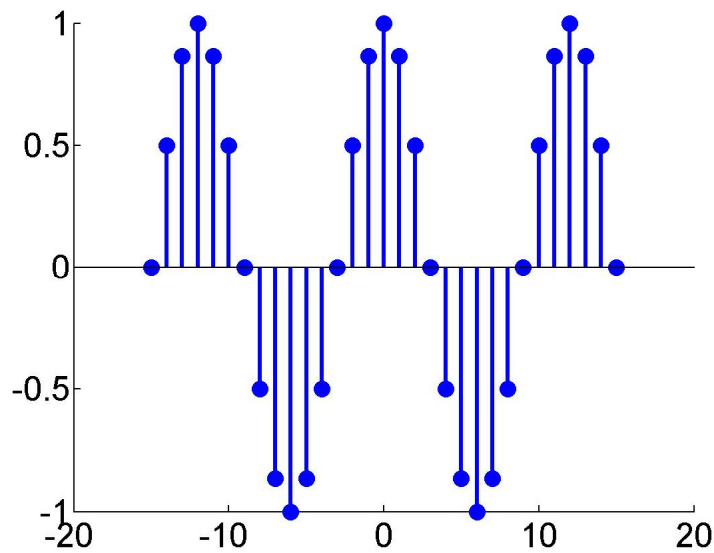

$$\cos\left(\frac{2\pi}{12}n\right)$$

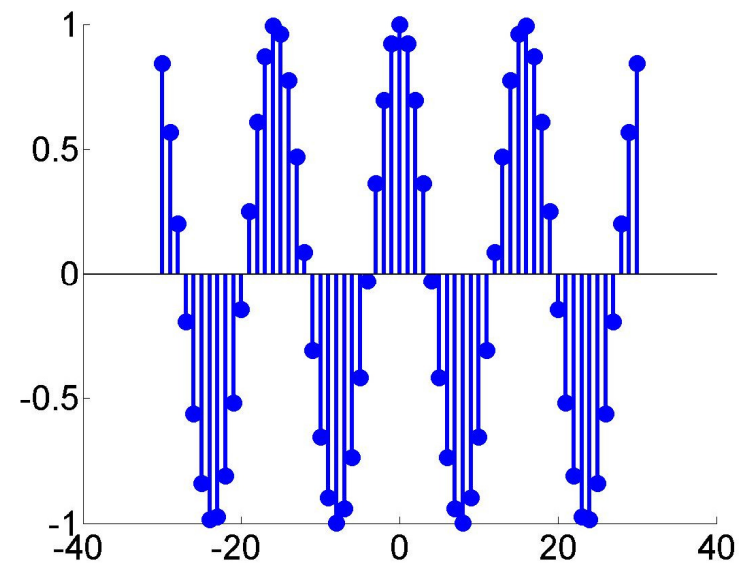

$$\cos(n/2.5)$$



## Segnali elementari tempo-discreto

c) I segnali:

$$\phi_k[n] = e^{jk \left( \frac{2\pi}{N} \right) n} \quad k = 0, \pm 1, \dots$$

con  $k$  intero sono in relazione armonica tra loro

- sono tutti periodici di periodo  $N$
- ci sono soltanto  $N$  distinti segnali  $\phi_k[n]$

**Caso generale:**

$$x[n] = C \left( |z| e^{j\omega_0} \right)^n \quad \text{con} \quad C = |C| e^{j\theta}$$

$$x[n] = |C| |z|^n \{ \cos(\omega_0 n + \theta) + j \sin(\omega_0 n + \theta) \}$$



# Segnali elementari tempo-discreto

Esempio:

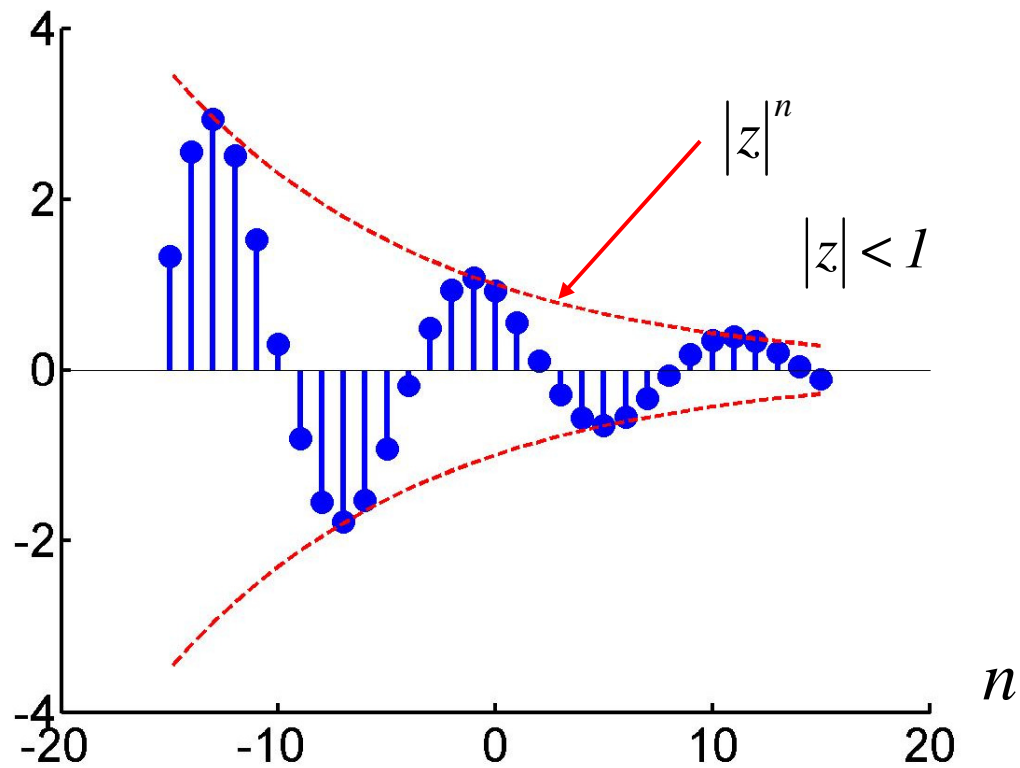

# Energia e potenza

Ipotesi:

il segnale  $x(t)$  ( $x[n]$ ) considerato rappresenti una tensione (o una corrente) applicata ad una resistenza di  $1$  ohm

$|x|^2(t)$  Potenza istantanea  
all'istante  $t$

$\int_{t_1}^{t_2} |x|^2(t) dt$  Energia sviluppata  
nell'intervallo  $t_2 - t_1$

$$T = t_2 - t_1$$

$\frac{1}{T} \int_{t_1}^{t_2} |x|^2(t) dt$  Potenza media  
nell'intervallo  $T$

$|x|^2[n]$  Potenza istantanea  
all'istante  $n$

$\sum_{n=n_1}^{n_2} |x|^2[n]$  Energia sviluppata  
nell'intervallo  $n_1, n_2$

$$N = n_2 - n_1 + 1$$

$\frac{1}{N} \sum_{n=n_1}^{n_2} |x|^2[n]$  Potenza media  
nell'intervallo  $N$



# Energia e potenza

## Classificazione segnali

### Segnali di energia

$$\int_{-\infty}^{+\infty} |x(t)|^2 dt = E < \infty$$

### Segnali di potenza

$$\int_{-\infty}^{+\infty} |x(t)|^2 dt = \infty$$

$$\lim_{T \rightarrow \infty} \frac{1}{T} \int_{-T/2}^{+T/2} |x(t)|^2 dt = P < \infty$$

### Segnali di energia

$$\sum_{n=-\infty}^{+\infty} |x|^2 [n] = E < \infty$$

### Segnali di potenza

$$\sum_{n=-\infty}^{\infty} |x|^2 [n] = \infty$$

$$\lim_{N \rightarrow \infty} \frac{1}{2N+1} \sum_{n=-N}^N |x[n]|^2 = P < \infty$$



## Riassunto

- trasformazioni di un segnale causate da trasformazioni della variabile tempo:  $t \rightarrow -t$ ,  $t \rightarrow t - t_0$ ,  $t \rightarrow at$
- alcuni segnali possono essere: pari, dispari, periodici
- principali segnali elementari a tempo continuo
  - impulso ideale  $\delta(t)$
  - gradino unitario  $u(t)$
  - esponenziale complesso ( $C \exp(\beta t)$ ,  $\exp(j\omega t)$ )
- principali segnali elementari a tempo discreto
  - impulso ideale  $\delta[n]$
  - gradino unitario  $u[n]$
  - esponenziale complesso ( $C z^n$ ,  $\exp(j\Omega n)$ )

