

Il legame chimico: l'importanza dei forti e la magia dei deboli

Prof. Lucia Pasquato

acqua



è un liquido a temperatura e pressione ambiente

MW 18 u.m.a.

t.eb. 100,00 °C

t.f. 0,00 °C

anidride carbonica o diossido di carbonio

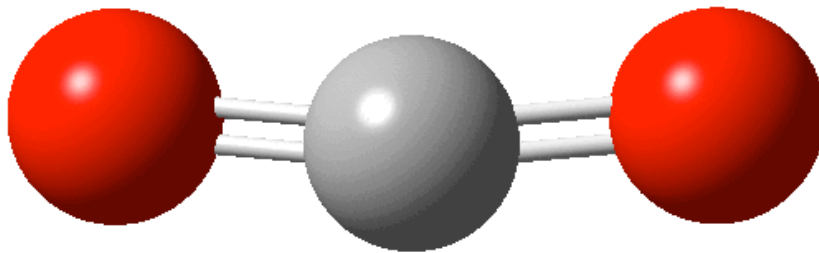

è un gas a temperatura e pressione ambiente

MW 44 u.m.a.

t.eb. -56,56 °C

t.f. -78,50 °C

Legami forti

I legami forti sono i **legami ionici** e i **legami covalenti**

I legami covalenti sono fondamentali per tenere uniti gli atomi che compongono una molecola in particolare nei composti organici.

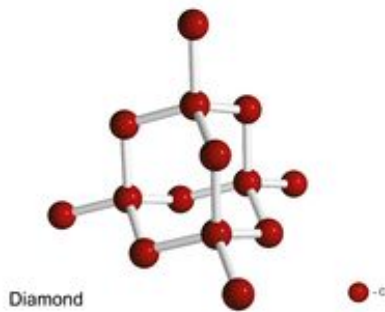

diamante

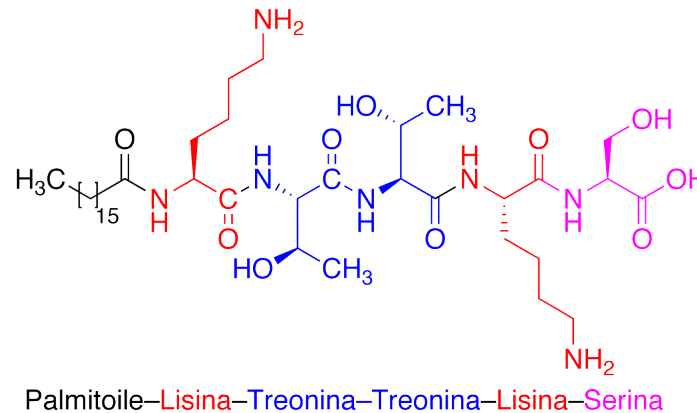

struttura primaria di proteine

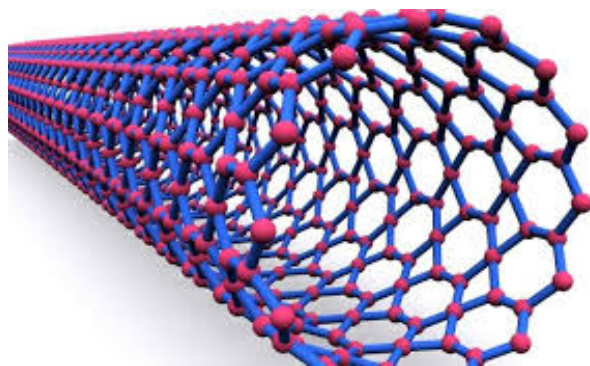

Nanotubi di carbonio

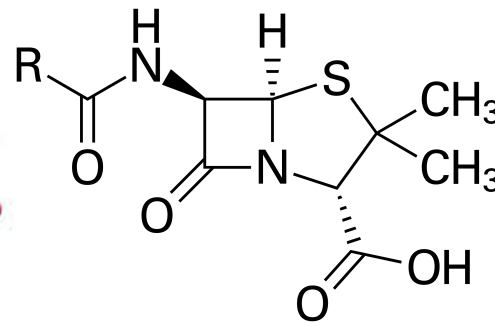

penicillina

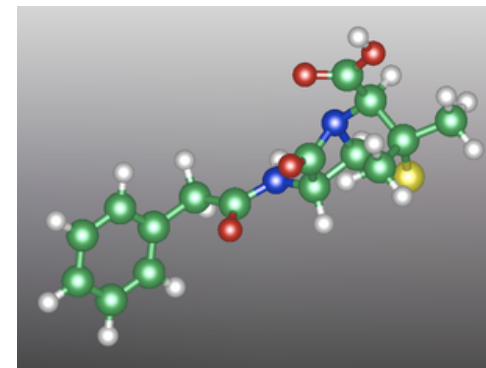
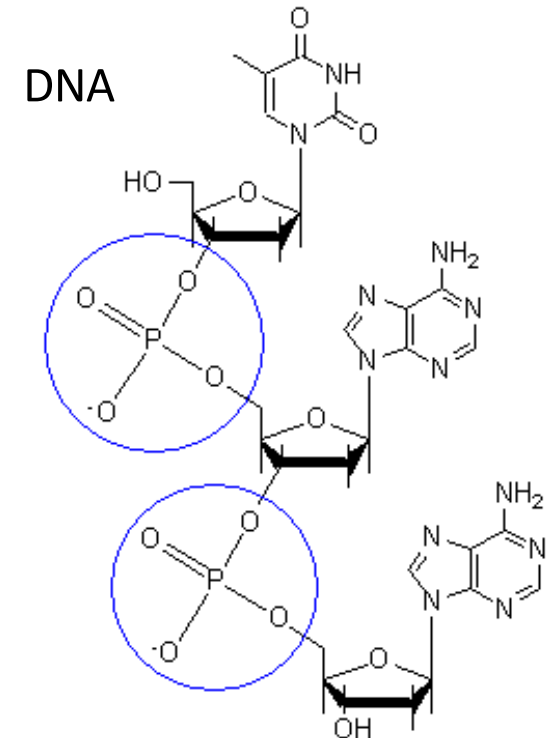

Legami forti

energie di legami covalenti

		kJ/mol	kcal/mol
Homonuclear diatomics	H-H	435	104
	F-F	159	38
	Cl-Cl	242	58
	Br-Br	192	46
	I-I	150	36
H-X bonds	H-F	568	136
	H-Cl	431	103
	H-Br	366	87.5
	H-I	297	71
	H-OH	497	119
	CH ₃ O-H	426	102

energie di legami covalenti

		kJ/mol	kcal/mol
C-H bonds	CH ₃ -H	435	104
	CH₃CH₂-H	410	98
	(CH ₃) ₂ CH-H	397	95
	(CH ₃) ₃ C-H	380	91
	C=C-H	450	108
	C≡C-H	535	128
	Ar-H	460	110
	C=CCH ₂ -H	368	88
	ArCH ₂ -H	355	85
C-C bonds	CH₃-CH₃	368	88
	CH ₃ CH ₂ -CH ₃	355	85
	(CH ₃) ₂ CH-CH ₃	351	84
	(CH ₃) ₃ C-CH ₃	334	80
C-X bonds	CH ₃ -NH ₂	364	87
	CH ₃ -OH	380	91
	CH₃-F	451	108
	CH₃-Cl	349	83.5
	CH₃-Br	293	70
Multiple bonds	C=C	611	146
	C≡C	837	200
	C=N	615	147
	C≡N	891	213
	C=O	749	179

legami deboli

Weak interactions are relatively weak compared to normal chemical bonds, but play a fundamental role in fields as diverse as:

- supramolecular chemistry,
- structural biology,
- polymer science,
- nanotechnology,
- surface science,
- and condensed matter physics.

Van der Waals forces define the chemical character of many organic compounds.

They also define the **solubility** of organic substances in polar and non-polar media.

For example, in low molecular weight alcohols, the properties of the polar hydroxyl group dominate the weak intermolecular forces of van der Waals.

In higher molecular weight alcohols, the properties of the nonpolar hydrocarbon chain(s) dominate and define the solubility.

Van der Waals-London forces grow with the length of the nonpolar part of the substance.

metanolo

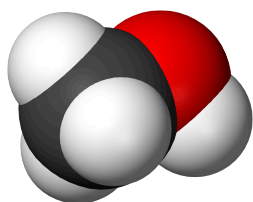

1-esanolo

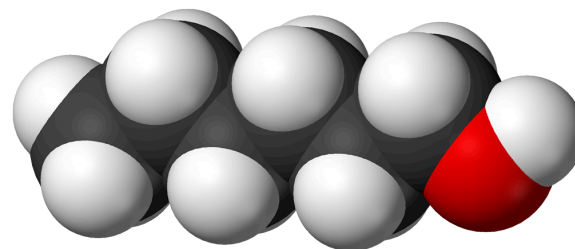

Supramolecular Chemistry

Supramolecular chemistry has been defined by Jean-Marie Lehn
“the chemistry of molecular assemblies and of the intermolecular bond”

The **Nobel Prize in Chemistry 1987** was awarded jointly to
Donald J. Cram, Jean-Marie Lehn and Charles J. Pedersen
*"for their development and use of molecules with structure-specific interactions
of high selectivity"*

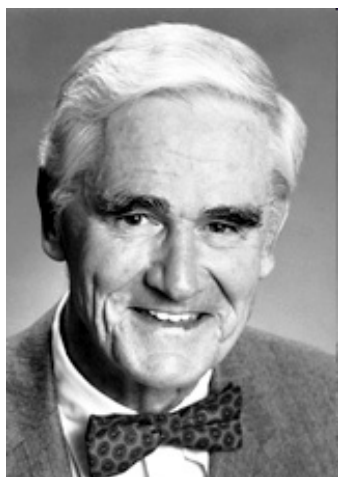

Donald J. Cram

University of California, Los Angeles,
CA, USA

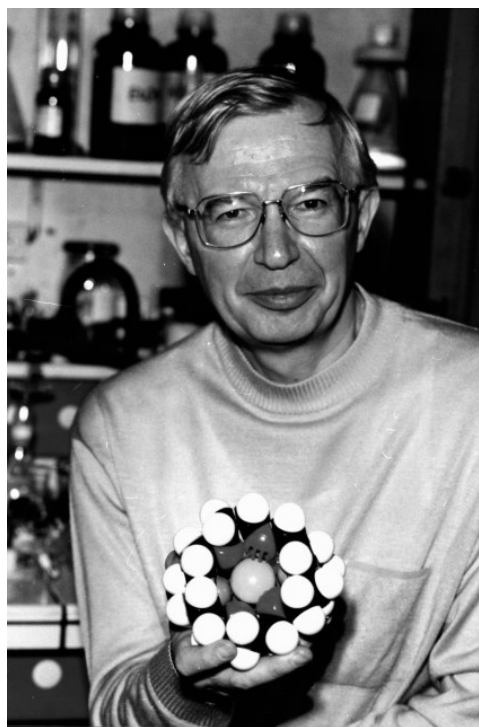

Jean-Marie Lehn

Université Louis Pasteur, Strasbourg, France,
Collège de France, Paris, France

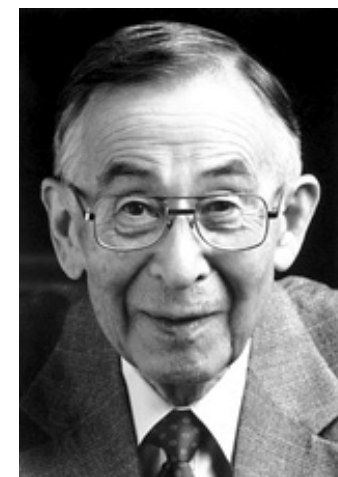

Charles J. Pedersen

Du Pont, Wilmington, DE, USA

riconoscimento molecolare

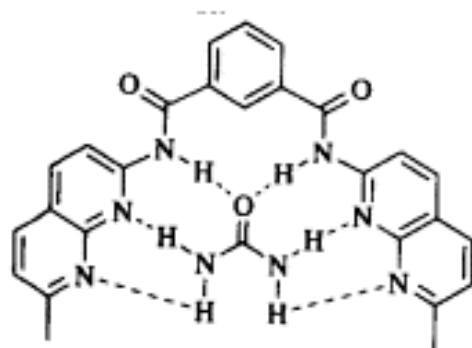
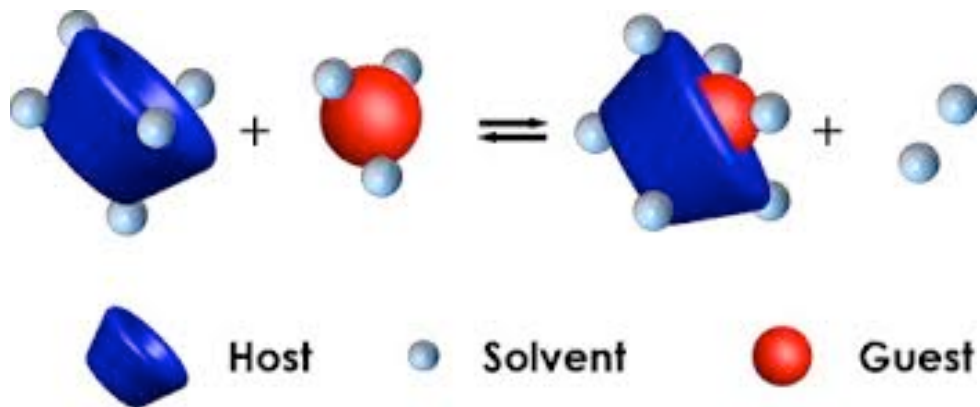

Urea Complex with 1

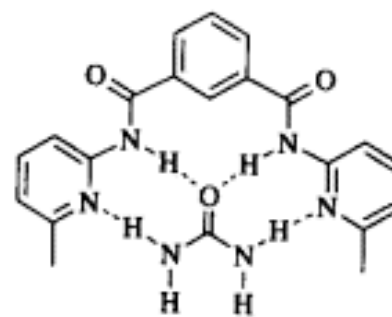

Urea Complex with 2

Additivity

In order to obtain a strong recognition between the host and the guest using weak non-covalent interaction, multiple interactions must be used.

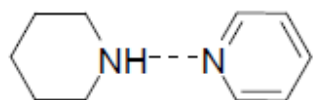

$$K_{\text{ass}} = 25 \text{ M}^{-1}$$

$$\text{DG} = -7.9 \text{ kJ mol}^{-1}$$

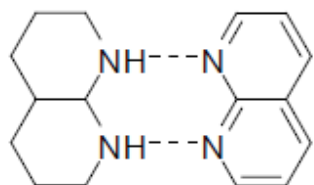

$$K_{\text{ass}} = 6.4 \times 10^3 \text{ M}^{-1}$$

$$\text{DG} = -21.6 \text{ kJ mol}^{-1}$$

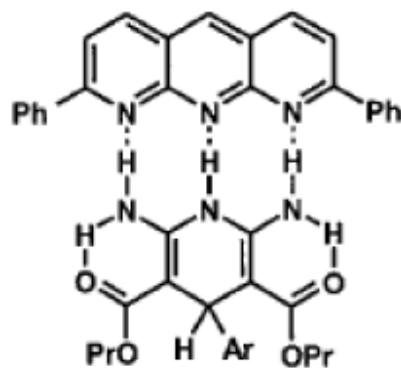

$$K_{\text{ass}} = 1.5 \times 10^6 \text{ M}^{-1}$$

$$\text{DG} = -35.3 \text{ kJ mol}^{-1}$$

Multivalenza e cooperatività



riconoscimento multivalente

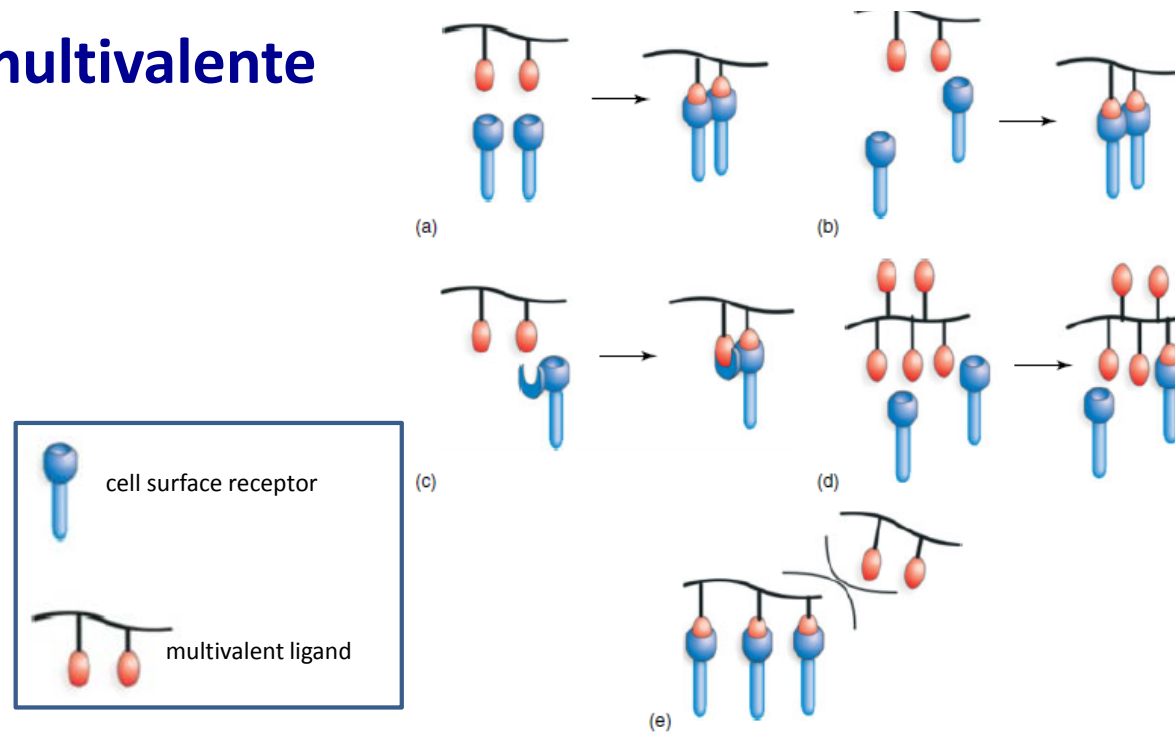
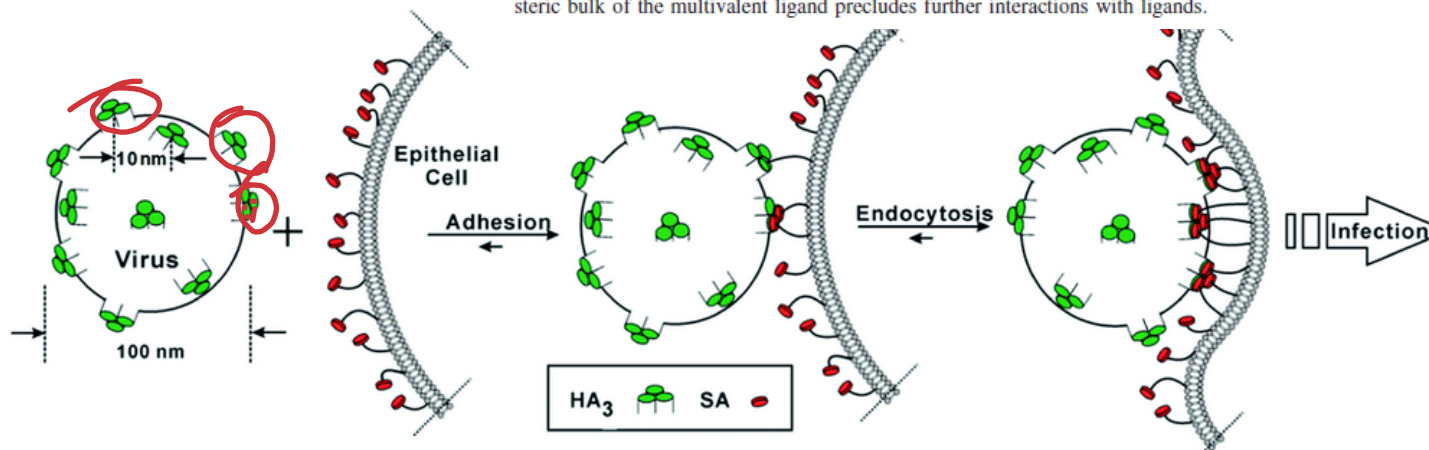

Figure 1 Mechanisms by which multivalent ligands can interact with cell-surface receptors. (a) Multivalent ligands can bind oligomeric receptors by occupying multiple binding sites (chelate effect). (b) Multivalent ligands can cause receptors to cluster on the cell surface. This can lead to activation of signaling pathways. (c) Multivalent ligands can occupy primary and secondary binding sites on a receptor. (d) Multivalent ligands display higher local concentrations of binding epitopes, which can result in higher apparent affinities. (e) The steric bulk of the multivalent ligand precludes further interactions with ligands.



macchine molecolari

The Nobel Prize in Chemistry 2016



Jean-Pierre Sauvage



Sir J. Fraser Stoddart



Bernard L. Feringa

"for the design and synthesis of molecular machines"

A Molecular Elevator

Jovica D. Badjić, Vincenzo Balzani, Alberto Credi,* Serena Silvi, J. Fraser Stoddart*

SCIENCE VOL 303 19 MARCH 2004

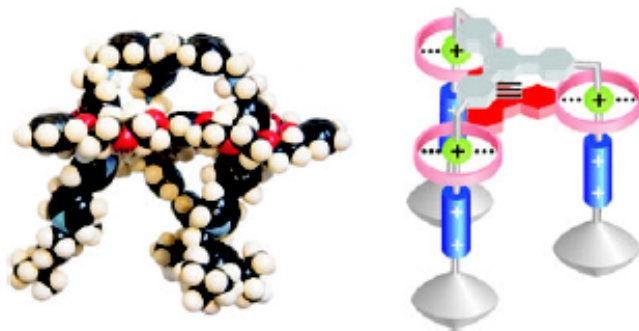
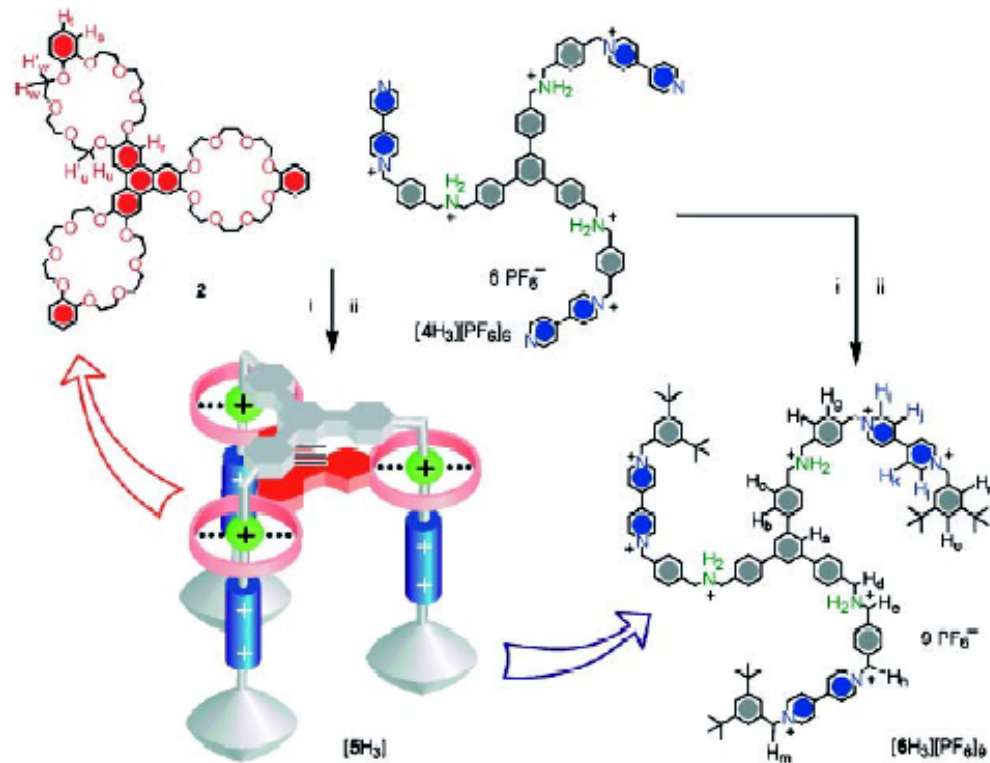
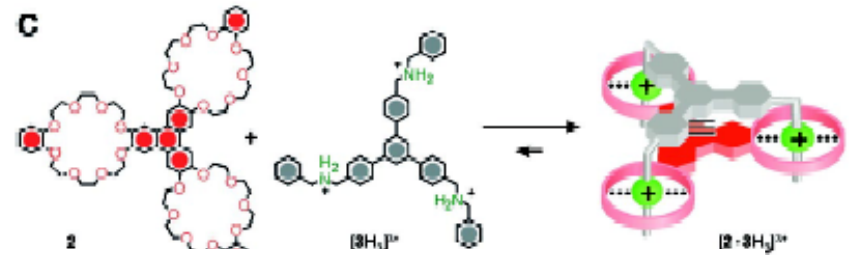
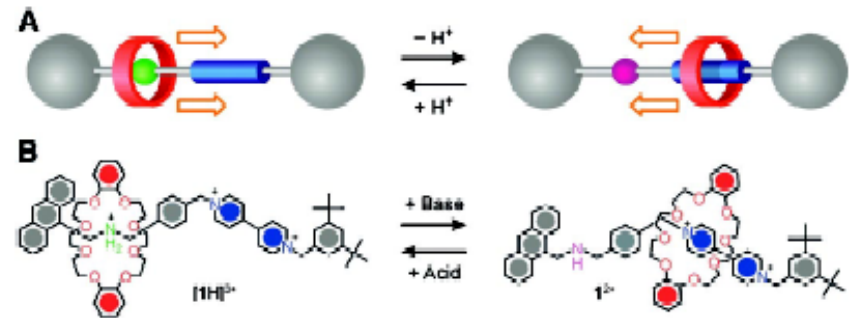

Figure 4. A molecular elevator: the red platform moves up and down upon the addition of acid and base, respectively.^[1A]



materiali organici

Light-driven monodirectional molecular rotor

Nagatoshi Koumura[†], Robert W. J. Zijlstra^{*}, Richard A. van Delden^{*}, Nobuyuki Harada[†] & Ben L. Feringa^{*}

^{*} Department of Organic and Molecular Inorganic Chemistry, Strating Institute, University of Groningen, Nijenborgh 4, 9747 AG Groningen, The Netherlands

[†] Institute for Chemical Reaction Science, Tohoku University, 2-1-1 Katahira, Aoba, Sendai 980-8577, Japan

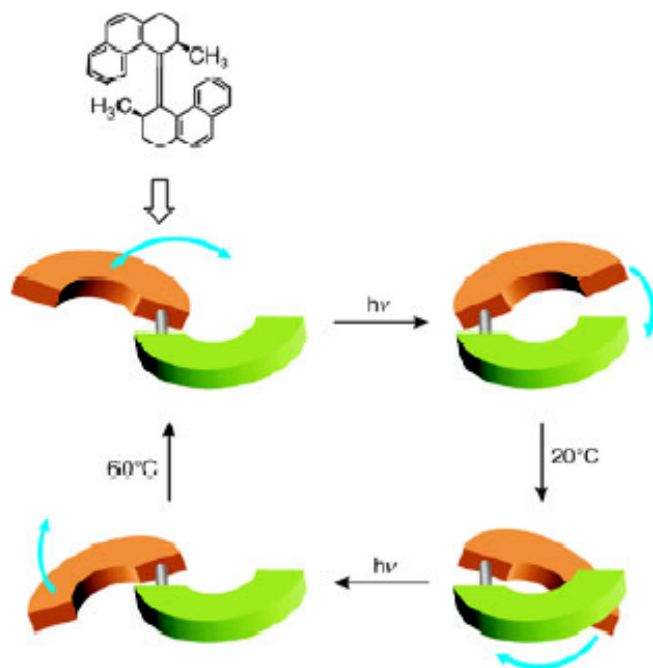

Figure 2. Structural formula and schematic representation of a molecular motor, based on the photoisomerization of an alkene-type compound containing chiral centers, that exhibits light-induced unidirectional rotation.^[11]

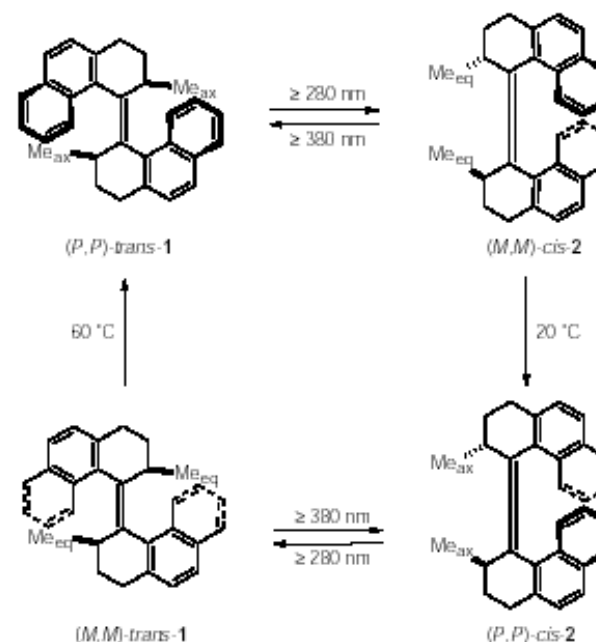
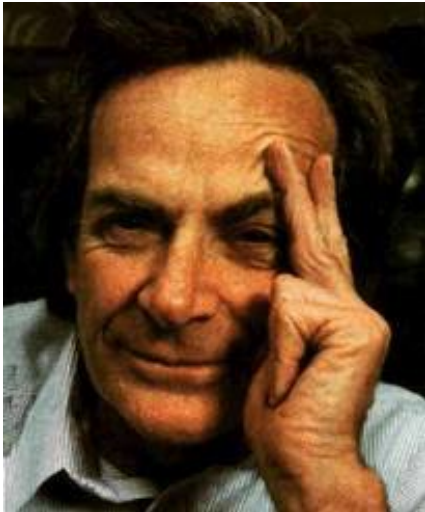

Figure 1 Photochemical and thermal isomerization processes of *(P,P)*-*trans*-1. UV irradiation with high pressure Hg-lamp, Pyrex filter, $\lambda \geq 280$ nm or Xe-lamp, Toshiba L-3g glass filter, $\lambda \geq 380$ nm. First order kinetics were observed for the thermal processes and temperature dependent ^1H NMR and CD studies in the range 50.0–81.1 °C gave $E_a = 26.4 \text{ kcal mol}^{-1}$ for the *(M,M)*-*trans*-1 to *(P,P)*-*trans*-1 interconversion. It should be noted that no racemization takes place during any of the photochemical or thermal steps as was proven by chiral HPLC analysis of the isomers obtained after the individual steps.

Nanoscience — The Interdisciplinary Science



In December of **1959**, the eminent physicist **Richard Feynman** (1965 Physics Nobel Prize) described the future in a groundbreaking talk entitled “**Plenty of Room at the Bottom**” about the physical possibilities for “*making, manipulating, visualizing and controlling things on a small scale,*” and imaging that in decades to come, it might be possible to arrange atoms “*the way we want.*”

“Why cannot we write the entire 24 volumes of the Encyclopaedia Britannica on the head of a pin?”

“..... and there is no question that there is enough room on the head of a pin to put all of the Encyclopaedia Britannica.”

nanomateriali

metodi di sintesi e fabbricazione di nanomateriali

approccio **top-down**: ricavare un oggetto più piccolo da uno più grande.

Questa tecnica comporta la riduzione delle dimensioni di un materiale fino a <10 nm.



i dispositivi sono fabbricati da materiali macroscopici attraverso un attento controllo dei processi di miniaturizzazione a livello atomico,

nanomateriali

metodi di sintesi e fabbricazione di nanomateriali

approccio **bottom up**: costruire dal basso usando elementi unitari, “**building blocks**”, per formare oggetti di dimensioni maggiori.

Il prodotto finale si ottiene assemblando progressivamente gli elementi costitutivi – atomi, ioni, molecole, nanoparticelle – per formare congegni, dispositivi, macchine a livello molecolare.

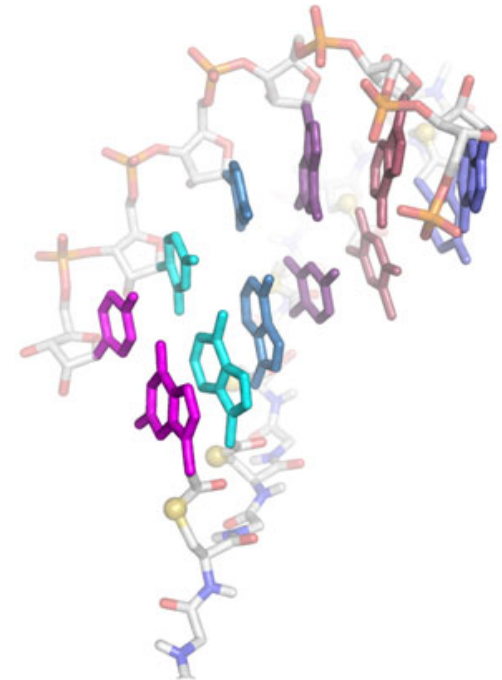
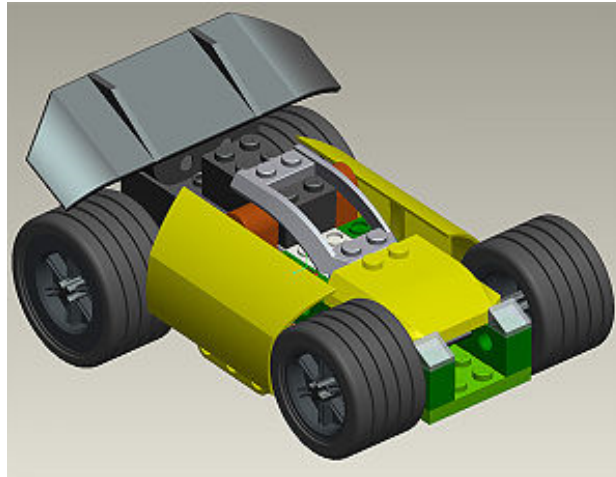

nanomateriali

self-assembly

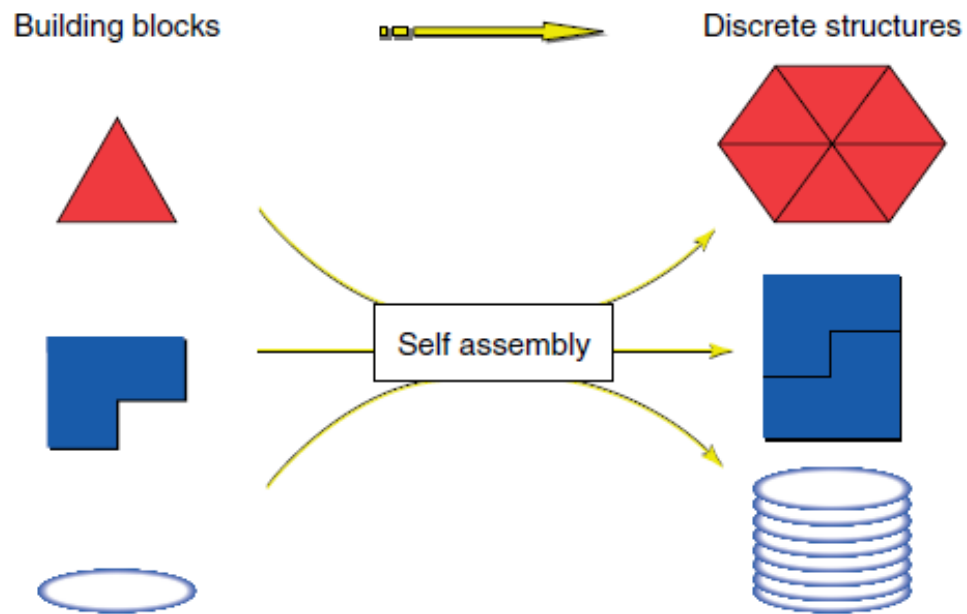
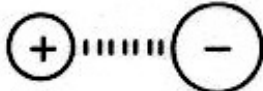
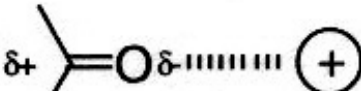
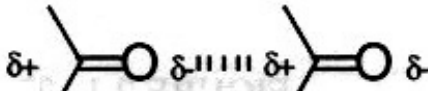
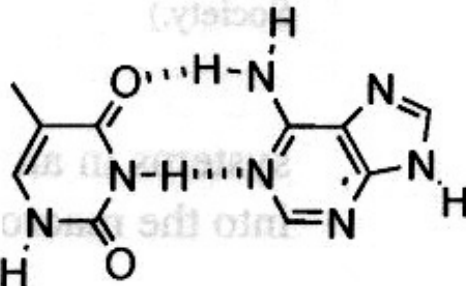

Figure 2 Schematic assembly of building blocks with various shapes to form discrete supramolecular structures.

Nature of Supramolecular Interactions - Legami deboli

TABLE 2.1. Intermolecular interactions

Interaction	Interaction Strength ^a (kJ mol ⁻¹)	Description	Example
Electrostatics	> 190 (ion-ion)	coulombic interactions between opposite charges	 ion-ion
	40–120 (ion-dipole)		 dipole-ion
	5–40 (dipole-dipole)		 dipole-dipole
Hydrogen bonding	15–40 (strong) 5–15 (moderate) <5(weak)	donor-acceptor interactions specifically involving hydrogen as the proton donor and a base as the proton acceptor	

Nature of Supramolecular Interactions - Legami deboli

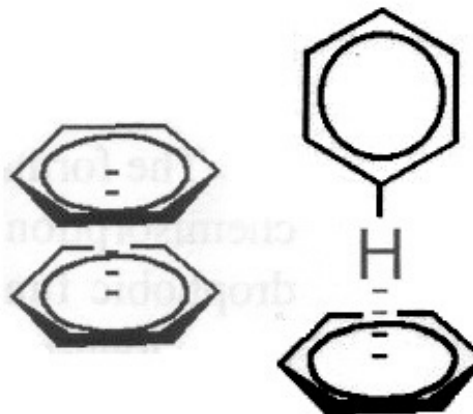
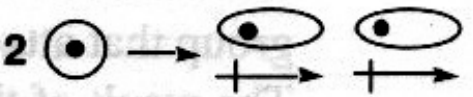
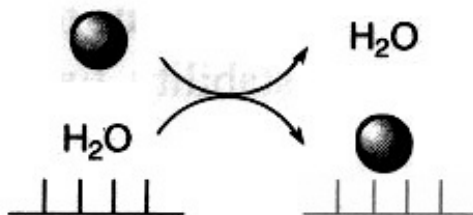
Interaction	Interaction Strength ^a (kJ mol ⁻¹)	Description	Example
π - π Interactions	10–15 (face to face) 15–20 (edge to face)	attractive forces between electron-rich interior of an aromatic ring with the electron-poor exterior of an aromatic ring	
Dispersion forces Van der Waals	<5	momentary induced dipole-dipole interactions (also called London forces)	
Hydrophobic effects	varied 5–40	association of non-polar binding partners in an aqueous medium or vice versa	

Nature of Supramolecular Interactions - Legami deboli

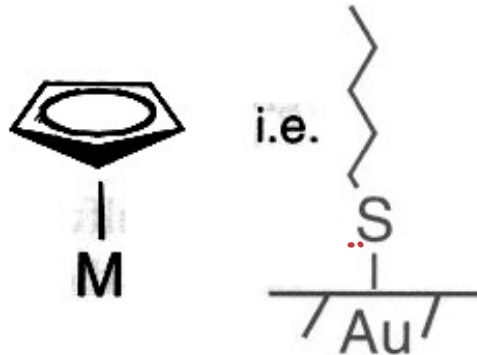
Interaction	Interaction Strength ^a (kJ mol ⁻¹)	Description	Example
Dative bonding	varied <u>20-380</u>	coordination of a metal by a ligand donating two electrons	 <p>The diagram illustrates two examples of dative bonding. On the left, a cyclopentadienyl ring is shown with a vertical line connecting it to a metal atom labeled 'M'. On the right, a thiolate ligand is shown with a vertical line connecting it to a gold atom labeled 'Au'. The thiolate ligand consists of a sulfur atom with two lone pairs of electrons (represented by two red dots) and a single bond to a gold atom. The sulfur atom is also bonded to a chain of four carbon atoms, represented by a zigzag line. The text 'i.e.' is placed between the two diagrams.</p>

^a Association constants are for systems in chloroform.

Nature of Supramolecular Interactions - Legami deboli

Halogen Bond (def. *Pure Appl. Chem.* **2013**, *85*, 1711)

A halogen bond $R-X \cdots Y-Z$ occurs when there is evidence of a net attractive interaction between an electrophilic region on a halogen atom X belonging to a molecule or a molecular fragment $R-X$ (where R can be another atom, including X, or a group of atoms) and a nucleophilic region of a molecule, or molecular fragment, $Y-Z$.

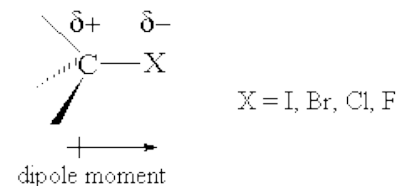

Halogen Bond Adducts

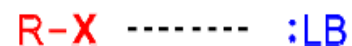

Halogen Bond Donor (Lewis Acid) *Halogen Bond Acceptor (Lewis Base)*

2.9 – 7.0 kJ mol⁻¹ 0.7 – 1.7 kcal/mol

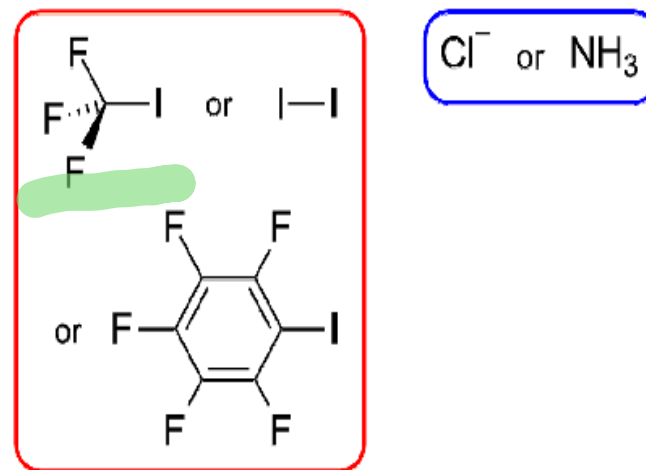
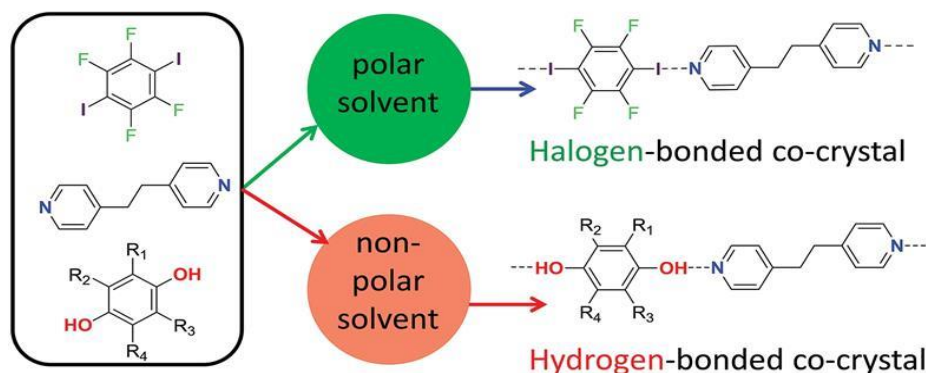

legami deboli

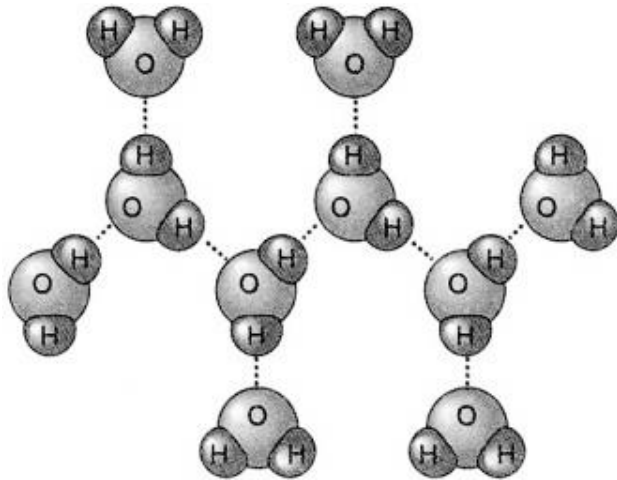

il **legame ad idrogeno** è un particolare tipo di **interazione dipolo-dipolo** che si viene a formare tra molecole nelle quali un atomo di idrogeno è legato covalentemente con un atomo di piccole dimensioni e fortemente elettronegativo (F, N e O).

Ne sono esempio l'acqua (H₂O),
l'ammoniaca (NH₃) e il fluoruro di idrogeno (HF)

legami deboli

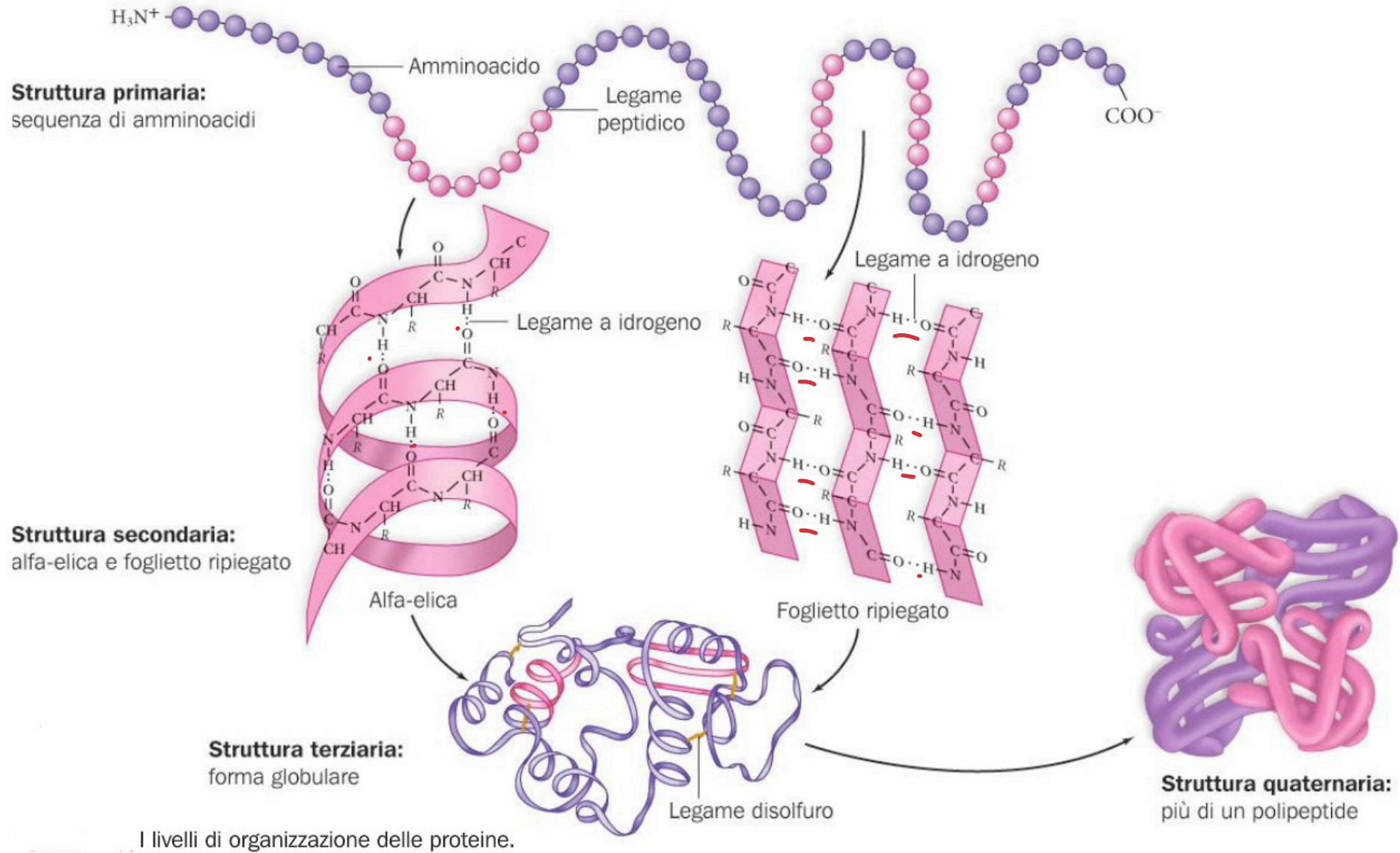

I livelli di organizzazione delle proteine.

legami deboli - legami ad idrogeno

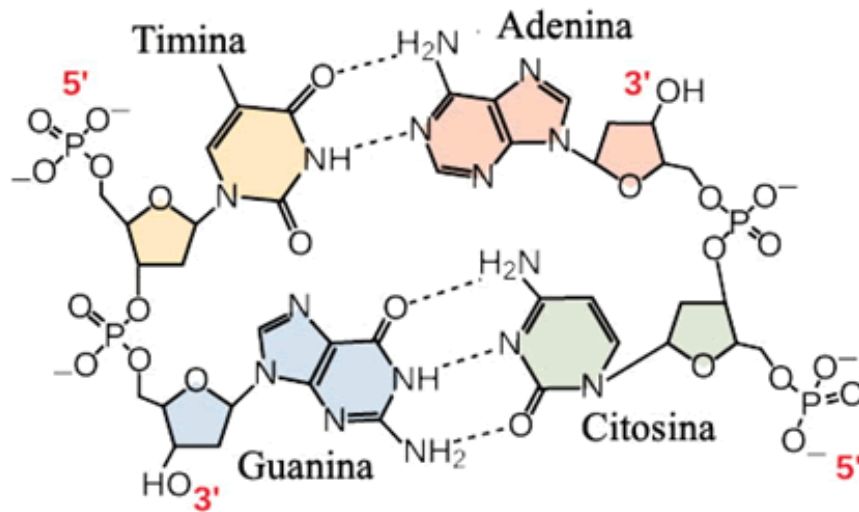

DNA



Double strand DNA

Its molecular structure was identified by James Watson and Francis Crick in 1953 (Nobel Prize 1962)

legami deboli - π - π staking

grafite

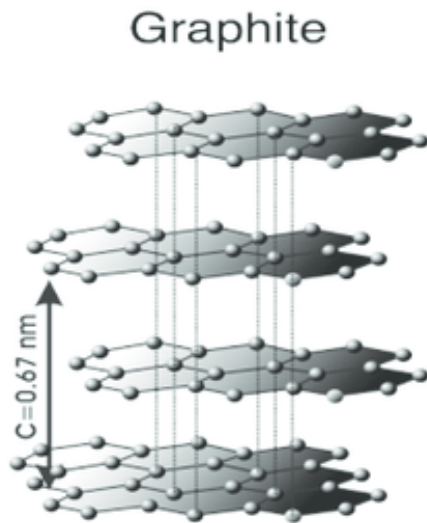
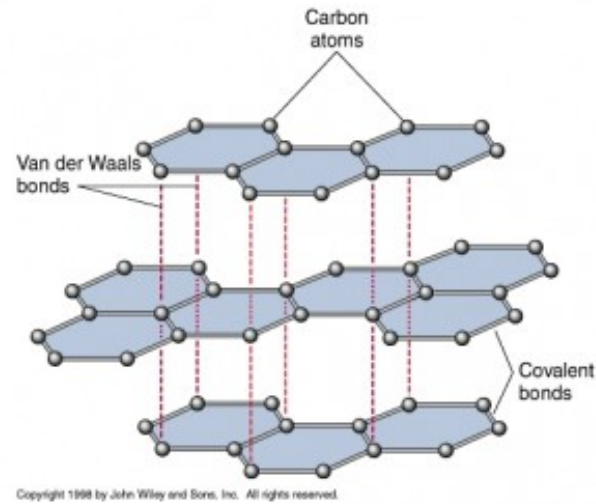

Exfoliation

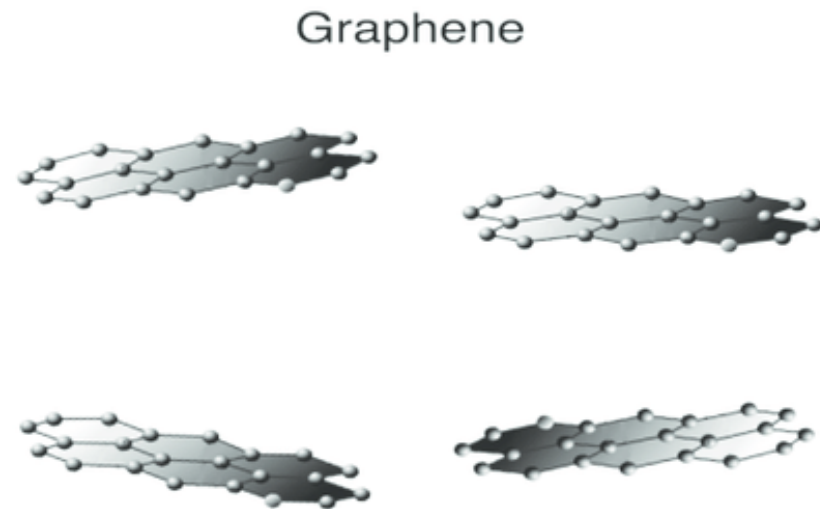

highly oriented pyrolytic graphite (HOPG)

legami deboli - van der Waals interactions

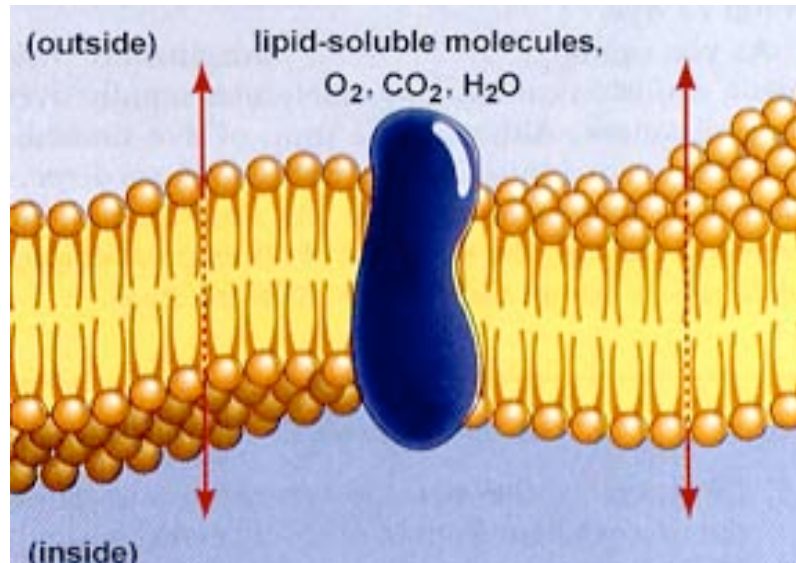

Fosfolipide di membrana (fosfatidilcolina)

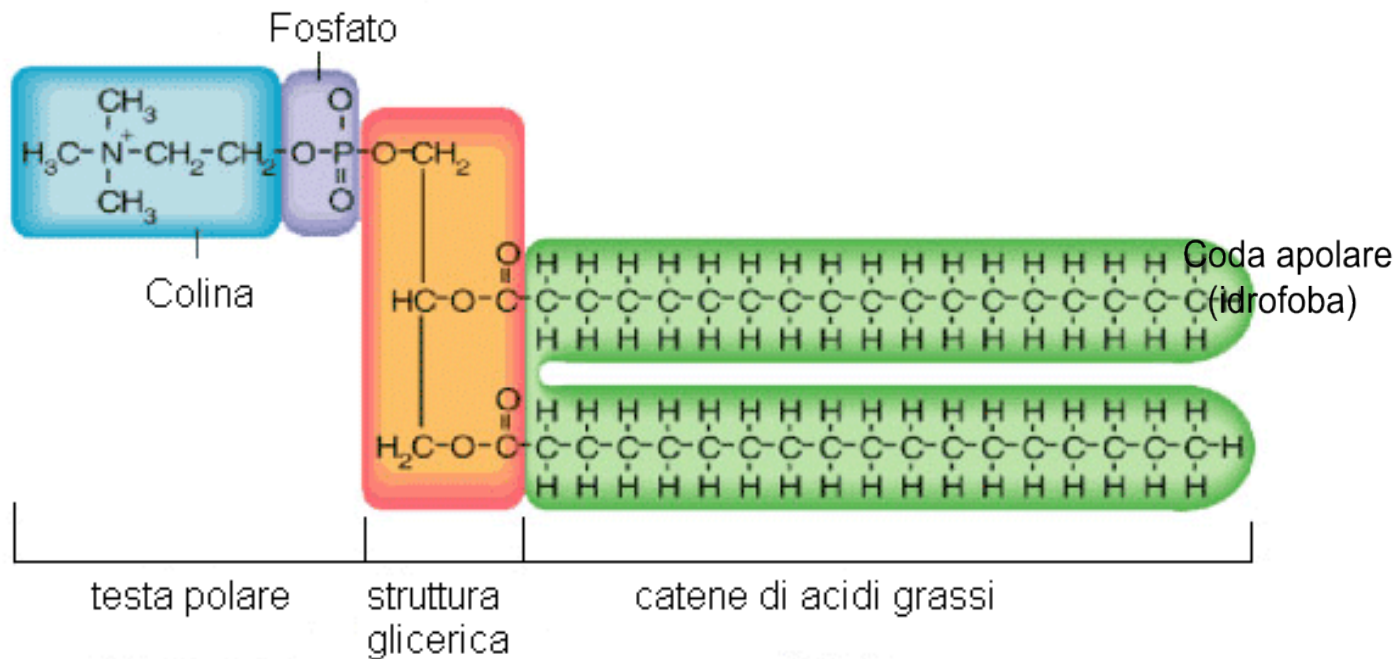
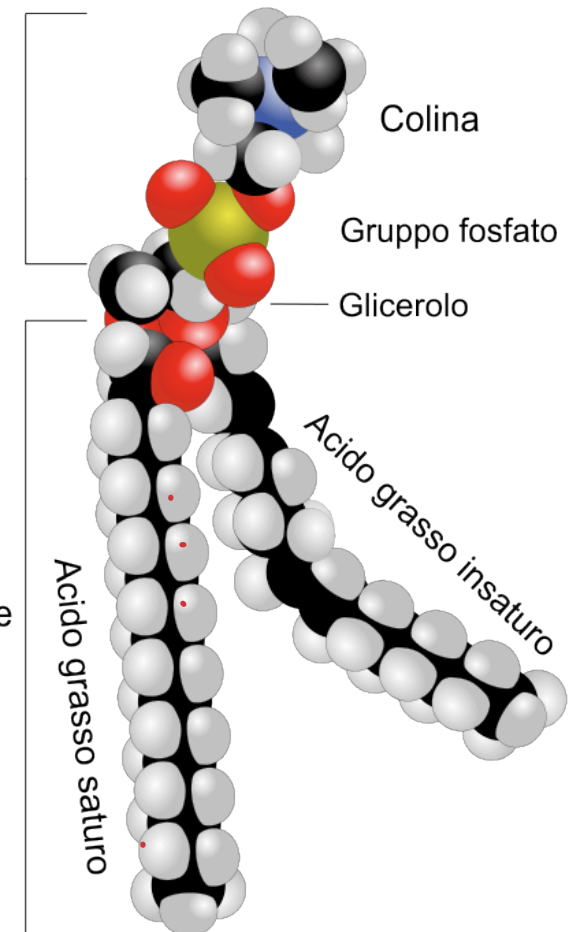

legami deboli - Van der Waals interactions

Monostrati auto-assemblati, 2D SAM

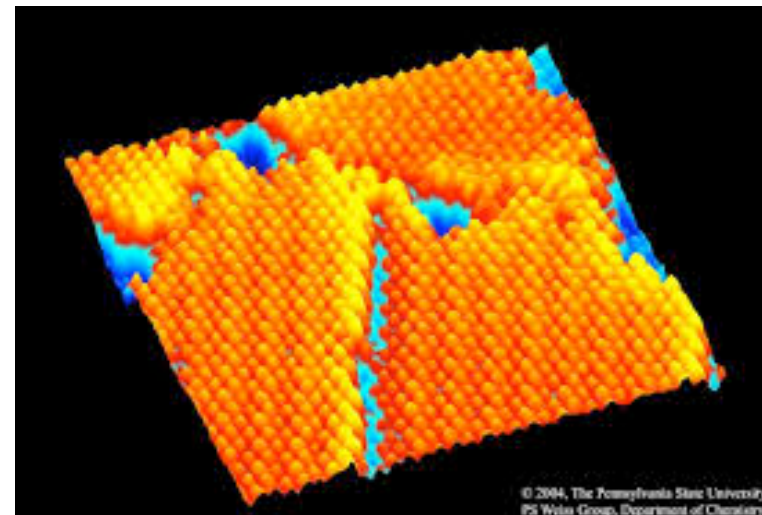
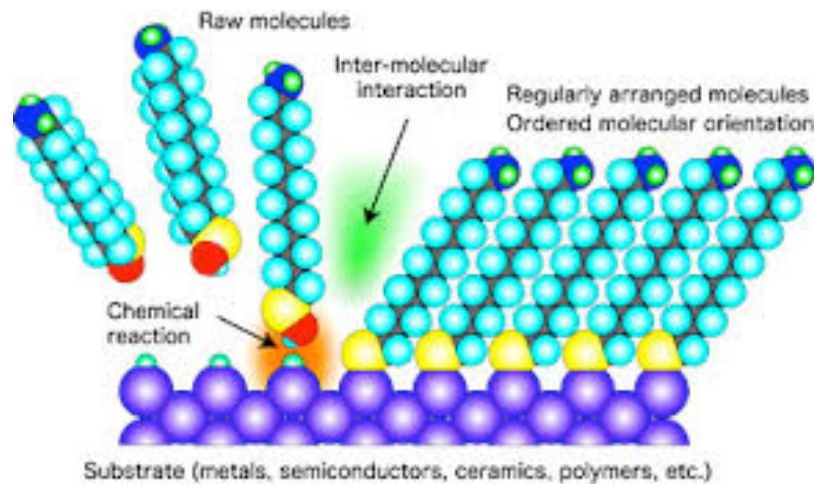

Monostrato trasparente che protegge le superfici
Rende la superficie idro- e/o oleo-repellenti, autopulenti
Devices for analysis
Molecular electronics
Etc.

Self-assembled monolayers on 2D surfaces

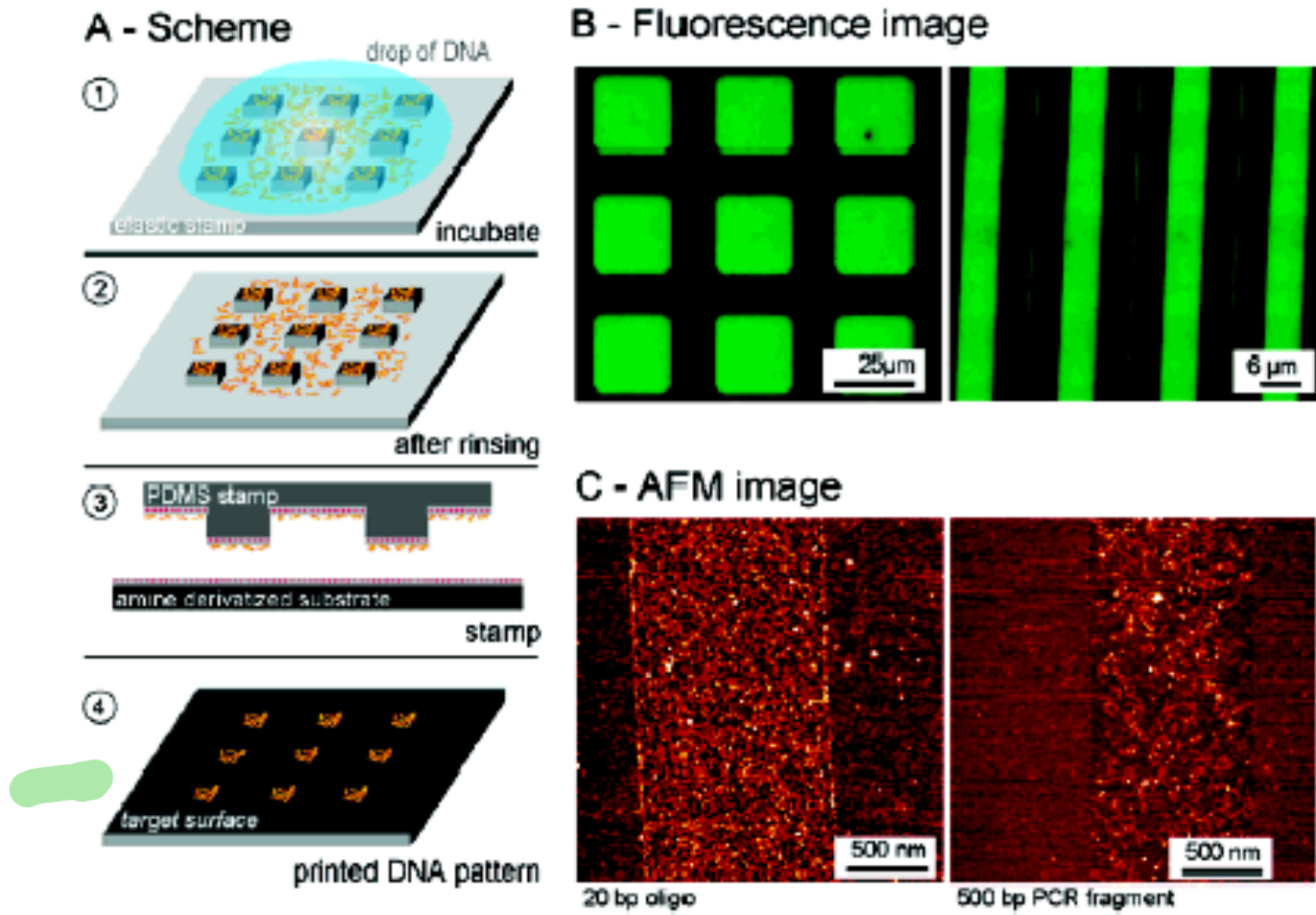

Self-assembled monolayers on 3D - sensors

Detection and identification of proteins using nanoparticle–fluorescent polymer ‘chemical nose’ sensors

C.-C. YOU, O. R. MIRANDA, B. GIDER¹, P. S. GHOSH, I.-B. KIM,
B. ERDOGAN¹, S. A. KROVI, U. H. F. BUNZ, VINCENT M. ROTELLO
nanotechnology VOL 2 | MAY 2007 , page 318

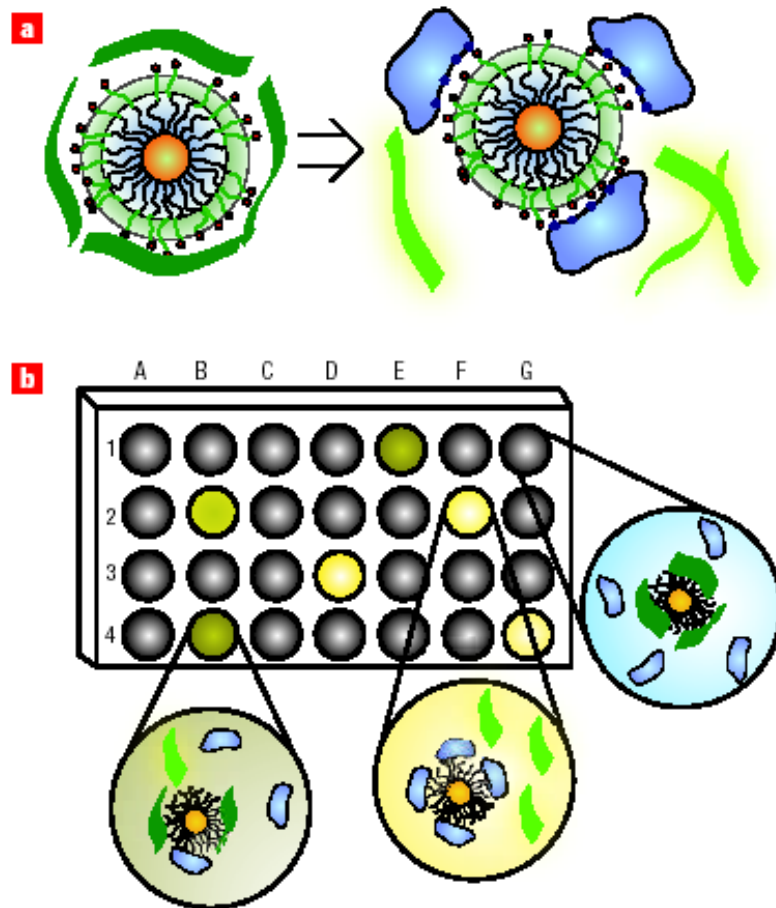

Figure 1 Fluorophore displacement protein sensor array. **a**, Displacement of quenched fluorescent polymer (dark green strips, fluorescence off; light green strips, fluorescence on) by protein analyte (in blue) with concomitant restoration of fluorescence. The particle monolayers feature a hydrophobic core for stability, an oligo(ethylene glycol) layer for biocompatibility, and surface charged residues for interaction with proteins. **b**, Fluorescence pattern generation through differential release of fluorescent polymers from gold nanoparticles. The wells on the microplate contain different nanoparticle–polymer conjugates, and the addition of protein analytes produces a fingerprint for a given protein.



.... la forza dei deboli