

Guidance Notes for the Classification of Special Service Craft

Version 1.0
Design Details
July 2014

Lloyd's Register is a trading name of Lloyd's Register Group Limited and its subsidiaries. For further details please see <http://www.lr.org/entities>

Lloyd's Register Group Limited, its subsidiaries and affiliates and their respective officers, employees or agents are, individually and collectively, referred to in this clause as 'Lloyd's Register'. Lloyd's Register assumes no responsibility and shall not be liable to any person for any loss, damage or expense caused by reliance on the information or advice in this document or howsoever provided, unless that person has signed a contract with the relevant Lloyd's Register entity for the provision of this information or advice and in that case any responsibility or liability is exclusively on the terms and conditions set out in that contract.

GUIDANCE NOTES ON DESIGN DETAILS

- Chapter 1 General Introduction**
- 2 Guidance for Designers for Steel/Aluminium Construction**
- 3 Construction Tolerances and Defect Correction Procedures for Steel/Aluminium Construction**
- 4 Detail Design Improvement for Steel/Aluminium Construction**
- 5 Detail Design Improvement for Composite Construction**

© Lloyd's Register Group Limited, 2014. All rights reserved.

Except as permitted under current legislation no part of this work may be photocopied, stored in a retrieval system, published, performed in public, adapted, broadcast, transmitted, recorded or reproduced in any form or by any means, without the prior permission of the copyright owner. Enquiries should be addressed to Lloyd's Register, 71 Fenchurch Street, London, EC3M 4BS.

CHAPTER	1	GENERAL INTRODUCTION
Section	1	Introduction
	1.1	Purpose of the Guidance Notes
	1.2	General
Section	2	Fatigue – General considerations
	2.1	Basis of the Guidance Notes
	2.2	Fatigue mechanism
	2.3	Allowable stresses
	2.4	Design loads
	2.5	Stress concentrations
	2.6	Stiffness
	2.7	Vibration
	2.8	Potential modes of failure
	2.9	Welds
	2.10	S-N curves
	2.11	Complexity of joint detail
	2.12	Surface properties
	2.13	Residual stress
	2.14	Compressive residual stress
	2.15	Grinding
CHAPTER	2	GUIDANCE FOR DESIGNERS FOR STEEL/ALUMINIUM CONSTRUCTION
Section	1	Introduction
	1.1	Definition
	1.2	General
	1.3	Application
Section	2	Fatigue strength improvement methods
	2.1	General
	2.2	Significant variables affecting fatigue strength improvement methods
	2.3	Design stage fatigue strength improvement methods
CHAPTER	3	CONSTRUCTION TOLERANCES AND DEFECT CORRECTION PROCEDURES FOR STEEL/ALUMINIUM CONSTRUCTION
Section	1	Introduction
	1.1	General
Section	2	Construction tolerances
	2.1	General
	2.2	Defects in steel/aluminium products
	2.3	Construction standards
	2.4	Prefabrication
	2.5	Assembly of units
Section	3	Defect correction procedures
	3.1	Inspection and testing
CHAPTER	4	DETAIL DESIGN IMPROVEMENT FOR STEEL/ALUMINIUM CONSTRUCTION
Section	1	Identification of critical areas
	1.1	General
	1.2	Critical areas
	1.3	Misalignment during construction
	1.4	Fatigue considerations
Section	2	Structural details
	2.1	Detail design improvement

CHAPTER 5 DETAIL DESIGN IMPROVEMENT FOR COMPOSITE CONSTRUCTION

- Section 1 Identification of critical areas**
- 1.1 General
 - 1.2 Critical areas
 - 1.3 Misalignment during construction
 - 1.4 Fatigue considerations

- Section 2 Structural details**
- 2.1 Detail design improvement

Section

- 1 **Introduction**
- 2 **Fatigue – General considerations**

■ *Section 1*
Introduction

1.1 Purpose of the Guidance Notes

1.1.1 With the advent of novel and high speed craft types the need for good structural detail has never been more important. Most structural failures that occur in the service life of a craft result from fatigue. A considerable amount of published data exists for more conventional steel vessels, however, little or no such data exists for the novel or high speed craft constructed from aluminium alloy or composite materials. Lloyd's Register (hereinafter referred to as LR) has amassed considerable knowledge in respect of structural detail which has demonstrated satisfactory service experience in resisting structural failure from fatigue. The details contained within these Guidance Notes are therefore provided to assist Builders and designers in identifying a minimum level of design detail which has provided acceptable levels of resistance to structural failure arising from fatigue.

1.1.2 It is not intended that the details contained within these Guidance Notes are the only solution to a particular structural design. Alternative structural details that have demonstrated satisfactory service experience will be acceptable.

1.2 General

1.2.1 Quality of detail design is fundamental if the craft's envisaged design life is to be attained. Experience over the past two decades, when structural concepts were revolutionised and aspects such as speed greatly increased, clearly indicated that areas of detail design became more prone to fatigue cracking with the traditional structural arrangements for details being used at that time.

1.2.2 Service experience has shown that provided the general concepts of a structural design are adequate then success or failure in structural terms will depend on the quality of detail design.

1.2.3 In general, the problems associated with aspects of detail design are those relating to fatigue ageing and failure.

1.2.4 Fatigue is failure under repeated loads. There are three phases in a fatigue fracture: crack initiation, crack propagation, and fracture. These phases are not completely separable. The process may be described as the formation of a crack, because of repeated local plasticity, its progression until a critical size is reached, where upon the structure fails. Fatigue accounts for a large percentage of all service failures.

1.2.5 A structural element can be subjected to various kinds of loading conditions, including fluctuating stress/strain, fluctuating temperature (thermal stress/strain), or any of these in a corrosive environment or at elevated temperatures. Most service failures occur as a result of tensile stresses.

1.2.6 Fatigue cracks generally initiate at high stress locations such as structural discontinuities, weld toes, matting in connections, etc. As these cracks propagate the ultimate load carrying capability of the structure is reduced until sufficient fatigue damage is accumulated for the structure to fail at normal working loads. Since fatigue cracks can be possible points of initiation for catastrophic failures or costly craft repairs, it is essential that fatigue is given more detailed consideration in the design of the structure.

1.2.7 Fatigue ageing of structural components is an accumulative process which is largely due to the environment and the loads experienced. An important realisation is that it is inevitable and where stress concentrations are present in association with significant magnitudes of stress variation then fatigue cracking will, in general, occur. Factors which influence performance, in that they affect the magnitude of stress ranges and provide stress concentrations, are as follows:

- (a) The loading experienced.
- (b) The quality of detail design.
- (c) The selecting of the type and grade of material.
- (d) The standard of workmanship in the craft construction.
- (e) Corrosion rates and magnitudes (metallic structures).
- (f) Erosion rates and magnitudes (composite structures).

1.2.8 Since the fatigue properties of higher tensile strength metallic materials are, in general, similar to those of the basic grade materials, the higher allowable stress magnitudes could entail a shorter fatigue life in standard details. Assuming that the fatigue life is a function of the stress range to the third power, it is clear that detail design requires special consideration to reduce the effects of stress concentrations. If higher tensile strength materials are incorporated and hence higher stress levels are accepted, then structural details, which would have been acceptable in mild steel structure manufactured from the basic grade material, might not be adequate.

1.2.9 The occurrence of cracking in craft is of prime concern from both a safety and maintenance point of view. Experience has shown that fatigue cracks in craft structures are normally of a self limiting nature. However, the existence of fatigue cracking may, if not repaired, render the structure susceptible to subsequent brittle or fast fracture. Thus both types of cracks are significant from a maintenance point of view. Fatigue cracks, if not repaired, may also initiate catastrophic failure as a consequence of the more extensive use of structural optimisation leading to a decrease in the level of structural redundancy.

■ Section 2 Fatigue – General considerations

2.1 Basis of the Guidance Notes

2.1.1 In assessing fatigue performance, the effect of cyclic loading should be taken into consideration. The types of cyclic loading experienced in service, will, in general, depend upon the size, type and speed of the craft. Cyclic wave induced loads created by the passage of waves along the craft sides and the associated local structural response create the highest risk for fatigue damage and cracking for large craft whereas, the major consideration for small high speed craft will relate to impact considerations, hard spots and discontinuities in the structure, etc.

2.1.2 Loading associated with bottom structures, in terms of hull girder response and local pressure variation, are heavily influenced by the length of waves and their direction in relation to the craft length and draught. Similarly, the deck structure is exposed to hull girder loads in response to relatively longer waves and cargo local loads arising from craft responses. Alternatively, these can be associated with structural discontinuities and slamming in shorter waves.

2.1.3 Deck and bottom longitudinal structure require attention to detail design and structural continuity to reduce the effects of stress concentration. Depending on the type of craft, the side shell structure may be exposed to dynamic loading from the internal pressure head from storage of consumables or cargo, in association with wave induced pressure variations, resulting in high cycle local bending stresses applied to the longitudinals and connection details at the transverse bulkhead stiffeners. This may transfer moments resulting in further increased stresses in the side longitudinals.

2.1.4 Every stress concentration and welded joint is a potential source of fatigue cracking and the design, taking note of symmetry, should reflect this. To ensure the structural integrity of the stiffening members particular attention should be given to the detail design. This document provides initial design guidance on fatigue and includes recommendations for the improvement of welded joint fatigue strength, or the bonded joint fatigue strength in the case of composite structures.

2.1.5 The fatigue strength of a structural detail is dependent on the following factors:

- (a) The direction of the fluctuating stress relative to the detail.
- (b) The location of initiating crack in the detail.
- (c) The geometrical arrangements and relative proportion of the detail.

It may also depend on:

- (d) The material (unless welded).
- (e) The method of fabrication.
- (f) The degree of inspection.

2.2 Fatigue mechanism

2.2.1 Fatigue damage starts prior to the initiation of a crack. With repeated loading, localised regions of slip (plastic deformation) develop. These deformations are accentuated by repeated loading, until a discernable crack finally appears.

2.2.2 The initial cracks form along slipped planes. The crack is crystallographically oriented along the slip plane for a short distance. This is sometimes referred to as Stage I crack growth. Eventually the crack propagation direction becomes macroscopically normal to the maximum tensile stress. This is referred to as Stage II crack propagation, and it comprises most of the crack propagation life.

2.2.3 The relative cycles for crack initiation and propagation depend on the applied stress. As the stress increases, the crack initiation phase decreases. At very low stresses (high cycle fatigue), therefore, most of the fatigue life is utilised to initiate a crack. At very high stresses (low cycle fatigue), cracks form very early. The separation of high and low cycle fatigue is not clear-cut. Generally, the low cycle region is that which results from stresses that are often high enough to develop significant plastic strains. It is usually assumed that the separation zone for low and high cycles is of the order of $10^4 - 10^5$ cycles to failure.

2.2.4 There are visual differences between high cycle (low stress) and low cycle (high stress) fatigue. In the latter, deformation resembles that seen with unidirectional loading. Strain hardening can occur and the slip bands are coarse. In high cycle fatigue, the slip bands are usually very fine.

2.3 Allowable stresses

2.3.1 For a particular craft component the allowable stresses should be in accordance with the requirements of LR's *Rules and Regulations for the Classification of Special Service Craft* (hereinafter referred to as the Rules for Special Service Craft).

2.4 Design loads

2.4.1 Applied design loads must take into consideration the appropriate environmental and dynamic conditions. Such loads are indicated in Part 5 of the Rules for Special Service Craft.

2.4.2 Realistic assessment of the fatigue loading is crucial to the estimation of fatigue life. Little or no published data for loading exists for the types of craft covered by the Rules for Special Service Craft. LR is conducting research in this field, the results of which will form the basis of Rules for Special Service Craft requirements in the future.

2.5 Stress concentrations

2.5.1 The design, fabrication and construction of all structural details should be based on procedures and processes to minimise stress concentrations.

2.5.2 Fatigue strength is seriously reduced by the introduction of a stress raiser such as a notch, of the method of termination of stiffeners and brackets, etc., or a hole. Since actual hull structure elements invariably contain stress raisers like fillet welds, end brackets, cut-outs, etc., it is not surprising to find that fatigue cracks in structural parts usually start at such geometrical irregularities. One of the most effective ways of minimising fatigue failure is by the reduction of avoidable stress raisers through careful design and the prevention of accidental stress raisers by careful processing and fabrication. While this section is concerned with stress concentrations resulting from geometrical discontinuities, stress concentration can also arise from surface roughness and metallurgical stress raisers such as porosity, inclusions, local overheating in grinding and decarburisation, etc., as appropriate to the construction material.

2.5.3 The effect of stress raisers on fatigue under uniaxial loading is that;

- (a) there is an increase or concentration of stress at the root of the notch,
- (b) a stress gradient is set up from the root of the notch,
- (c) a triaxial state of stress is produced.

2.5.4 The ratio of the maximum stress to the nominal stress is the Stress Concentration Factor.

2.5.5 Values of the stress concentration factor will vary depending upon:

- (a) the severity of the notch,
- (b) the type of notch,
- (c) the material,
- (d) the type of loading, and
- (e) the stress level.

2.6 Stiffness

2.6.1 Abrupt changes in stiffness of the structure should be avoided as they can induce local stress concentrations and reductions of fatigue life.

2.7 Vibration

2.7.1 If possible, precautions should be taken in the design against the possibility of excessive structural vibration being induced, for example, by machinery. This would entail investigation of the natural frequencies of the panel members and of the sources of excitation.

2.8 Potential modes of failure

2.8.1 The potential modes of fatigue failure are dependent upon the direction of the applied stress relative to the position of the weld and the position of stress concentrations due to structural discontinuities.

2.8.2 For longitudinal butt welds in plates, dressed flush, and lying parallel to the direction of applied stress, the initiation of potential fatigue failures is expected to be found at weld defect locations. In the 'as-welded' condition, fatigue cracks may be initiated at the weld start-stop positions or, weld surface ripples.

2.8.3 For transverse butt welds in plates, essentially perpendicular to the direction of applied stress, the fatigue strength depends largely upon the shape of the weld profile. Fatigue cracks normally initiate at the weld toe.

2.8.4 Cruciform fillet weld joints associated with the four way connection of plate or stiffeners, may be separated into two distinct types depending on whether or not the fillet weld transmits direct load i.e. non-load carrying or load carrying cruciform joints. In the case of the non-load carrying cruciform joint, the fatigue crack will initiate at the weld toe and propagate through the thickness of the load bearing plate in a plane perpendicular to the direction of the applied stress.

2.8.5 In load carrying cruciform joints, in addition to the weld toe, acute stress concentration occurs at the root of the fillet weld and generally fatigue cracks are initiated at the root of the weld and propagate through the weld throat. The fatigue life of such connections can be improved either by increasing the throat size of the fillet weld or by requiring improved weld penetration. In high stress regions however, such measures may not be adequate and there is then a need to specify a full penetration weld in order to achieve the necessary fatigue life for the joint.

2.8.6 Tee joints, since they represent a semi-cruciform joint in a three way connection of plates or stiffeners, would be expected to demonstrate similar fatigue characteristics to the load bearing cruciform joint. However, if bending stresses are induced in the base plate material of the tee, which are of a similar or greater magnitude than the direct stress in the tee, then a fatigue crack may initiate in the base plate at the toe of the fillet weld and propagate through the base plate.

2.8.7 Where tee or cruciform connections employ full penetration welds, and the plate material is subject to significant strains in a direction perpendicular to the rolled surfaces, it is recommended that consideration be given to the use of special plate material with specific through thickness properties, as detailed in Ch 3.8 of the *Rules for Manufacture, Testing and Certification of Materials* (hereinafter referred as the Rules for Materials).

2.8.8 For welded stiffeners and girders, fatigue cracks can be expected to be initiated at weld toes and may be associated with local stress concentrations at the weld ends of connecting end brackets or stiffeners.

2.8.9 The most common sites for potential fatigue cracks therefore are:

- (a) Toes and roots of fusion welds.
- (b) Machined corners.
- (c) Drilled holes, cut-outs or other openings.

2.8.10 The main conditions affecting fatigue performance are:

- (a) High ratios of dynamic to static loads.
- (b) Loading frequency.
- (c) Material selection.
- (d) Welding.
- (e) Complexity of joint detail.
- (f) Environment.

2.8.11 For craft operating for long periods in low air temperatures, or high temperatures for composites, the material of exposed structures will need to be specially considered.

2.9 Welds

2.9.1 Some commonly used weld details have low fatigue strength. This applies not only to joints between members, but also to any attachment to a loaded member, whether or not the resulting connections are considered to be structural.

2.9.2 The heat-affected zone (HAZ) is of great importance to the fatigue strength of welds because this is usually the region where a fatigue crack will develop. Moreover, when the reinforcement of a butt weld is not removed, or when fillet welds are used, a resulting sudden change of section occurs, and stress concentrations occur at the weld toe.

2.9.3 For the specification of welding and structural details, see Pt 6, Ch 2 and Pt 7, Ch 2 of the Rules for Special Service Craft for steel and aluminium alloy craft respectively.

2.10 S-N curves

2.10.1 A material's fatigue characteristics are fatigue strength and fatigue limit.

2.10.2 The fatigue strength is the stress value beyond which the material will fail at a specified number of stress cycles.

2.10.3 The fatigue limit is the fatigue strength corresponding to an infinite number of stress cycles.

2.10.4 The S-N curve represents the dependence of the life of the 'specimen' in a number of cycles, N, to the maximum applied stress, S. N is usually taken (unless specified otherwise) as the number of stress cycles to cause a complete fracture in the 'specimen'.

2.10.5 Usually no distinction is made between the number of cycles to initiate a crack and the number of cycles to propagate the crack completely through the specimen, although it can be appreciated that the number of cycles for crack propagation will vary with the dimensions of the specimen. Fatigue tests for high cycle fatigue are usually carried out for $10^5 - 10^7$ cycles and sometimes to 5×10^8 cycles for non-ferrous metals. For a few important engineering materials such as steel and titanium, the S-N curve becomes horizontal at a certain limiting stress. Below this limiting stress, which is called the fatigue limit, or endurance limit, the material can presumably endure an infinite number of cycles without failure.

2.11 Complexity of joint detail

2.11.1 Complex joints frequently lead to high stress concentrations due to local variations on stiffness and load path. Whilst these may have little effect on the ultimate static capacity of the joint they can have a severe effect on fatigue resistance.

2.11.2 If fatigue control is the dominant criteria, the member cross-sectional shape should be selected to ensure smoothness and simplicity of joint design, so that stresses can be calculated and adequate standards of fabrication and inspection assured.

2.11.3 The best fatigue behaviour will be obtained by ensuring that the structure is detailed and constructed so that stress concentrations are kept to a minimum and that, where possible, the elements may deform without introducing secondary deformations and stresses due to local restraints.

2.11.4 Stresses may be reduced by increasing the thickness of the parent metal and this would theoretically increase fatigue life due to a reduction of the nominal stresses. However, it should be borne in mind that fatigue strength decreases, in general, with increasing thickness.

2.12 Surface properties

2.12.1 Since fatigue failure is dependent on the condition of the surface, anything that changes the fatigue strength of the surface material will greatly alter the fatigue properties.

2.12.2 As an example most mechanically finished metallic parts have a shallow surface layer in residual compression. Aside from the effect on surface roughness, the final surface finishing process will be beneficial to fatigue when it increases the depth and intensity of the compressively stressed layer and detrimental when it decreases or removes this desirable layer. Thus sandblasting, glass bead peening, burnishing, and other similar operations generally improve fatigue properties.

2.13 Residual stress

2.13.1 Residual stresses arise when plastic deformation is not uniform throughout the entire cross section of the detail being deformed. They therefore comprise a system of internal stresses in the material balanced within the material itself and can exist in the absence of any external loading. Thus if there is an area of tensile residual stress in any cross section at one part of a material there must be a residual compressive stress at some other point. There would in addition be a variation of stress through the thickness of the material, particularly for thicker sections.

2.13.2 In a welded joint residual stresses are induced as a consequence of local heating and cooling cycles associated with the welding procedure and in particular the shrinkage of the weld metal. The actual situation in a welded joint is complicated by practical factors such as the type and size of joint, the welding process used and the weld procedure. In a butt weld for example, high residual tensile stress will exist in the direction of the weld and at right angles to it. In the case of multi-pass or high energy welding these residual stresses may reach the level of the yield strength of the material. As such tensile residual stresses can occur in locations where fatigue cracks are likely to initiate, it will be appreciated that they can lead to a proportional reduction in the fatigue strength of a joint when it is subjected to additional dynamic tensile loads.

2.14 Compressive residual stress

2.14.1 The formation of a favourable compressive residual-stress pattern at the surface is probably the most effective method of increasing fatigue performance. As indicated in 2.13, residual stresses are locked-in stresses which are present in a part which is not subjected to an external force. Only macro-stresses, which act over regions which are large compared with the grain size, are considered here.

2.14.2 In general, for a situation where part of the cross section is deformed plastically while the rest undergoes elastic deformation, the region which was plastically deformed in tension will have a compressive residual stress after unloading, while the region which was deformed plastically in compression will have a tensile residual stress when the external force is removed. The maximum value of residual stress which can be produced is equal to the elastic limit of the metal.

2.14.3 The high compressive residual stresses at the surface must be balanced by tensile residual stresses over the interior of the cross section.

2.14.4 The improvement in fatigue performance, which results from the introduction of surface compressive residual stress, will be greater when the loading is one in which a stress gradient exists than the case when no stress gradient is present.

2.14.5 It is important to recognise that improvements in fatigue properties do not automatically result from the use of shot peening or surface rolling. It is possible to damage the surface by excessive peening or rolling.

2.14.6 In order for the desirable effect of surface cold working to be maintained, the cold-working process must be accomplished in the final heat-treated condition and subsequent thermal treatment eliminated when feasible and closely controlled when essential. Exposure of cold-worked surfaces to elevated temperature initially results in stress relief of the plastically deformed zone and ultimately in recovery or perhaps re-crystallisation of the work-hardened area, with complete loss of the desirable residual stress gradient.

2.15 Grinding

2.15.1 There are some processes that are capable of developing high localised surface temperatures which are often difficult to detect and occasionally are responsible for a failure in service. Grinding can be one of these processes.

2.15.2 The rapid quenching of the material immediately below the grinding wheel by the large mass of cold metal can produce cracks or 'check'. High strength steels (for which grinding is most often used) are particularly sensitive to grinding techniques.

Section

- 1 **Introduction**
- 2 **Fatigue strength improvement methods**

■ Section 1 Introduction

1.1 Definition

1.1.1 **Critical areas** can be defined as locations that, by reason of stress concentration, alignment/discontinuity and corrosion will have a higher probability of failure during the life of the craft than the surrounding structures. **Critical locations** are defined as the specific locations within the critical area that can be prone to fatigue damage for which design improvements are provided.

1.2 General

1.2.1 In order to assist the designer to minimise fatigue failures, LR has developed an extensive database on structural detail design aspects.

1.2.2 Utilising the results from detailed finite element analyses for an extensive range of structural details it has been possible to examine a variety of configurations for each detail thereby enabling a grading to be made of their relative fatigue performance.

1.2.3 The outcome from some of this work has been condensed into these Guidance Notes. It is intended as a conservative approach to improving the fatigue life performance of structural details.

1.2.4 The designer may therefore, using these Guidance Notes, readily upgrade the detail design arrangements to provide a higher fatigue performance configuration.

1.2.5 It is intended that the detail design database given in Chapter 4 will be extended to incorporate further detail arrangements, to reflect in-service experience of their fatigue performance, design and construction practice, as well as any significant data made available from research studies.

1.2.6 In addition, guidance is provided to the designer and Builder on other methods to improve the fatigue life performance of the structural detail such as detail geometry, construction tolerances, welding sequence, weld defect, weld dressing, etc.

1.3 Application

1.3.1 The detail design improvements provided in these Guidance Notes are applicable to all grades of steel, commonly used aluminium alloys and composite structures. This is because the fatigue life improvement will be achieved through the suggested change of **geometry** which will reduce the stress concentrations and the **improved construction** requirements which will improve the performance throughout the design lifetime of the structural detail under the expected stress variations.

1.3.2 In areas where **mild steel** and basic grade aluminium may be used a number of the suggested detail improvements may not be necessary due to the lower stress ranges that the details are designed to experience. However, in areas where **higher tensile steel** (HTS) or higher strength grade aluminium are used, the operating stresses will generally be higher. Therefore the detail improvements suggested may become necessary in order to meet the fatigue strength of the structure.

1.3.3 **Alternative structural arrangements** will, in general, be acceptable provided it can be demonstrated, that a satisfactory fatigue life performance will be maintained throughout the design life span. In addition the structural arrangements and scantlings are to satisfy the Rules for Special Service Craft.

1.3.4 Where suggested values are indicated regarding geometries or scantlings, these are given as guidance.

■ Section 2 Fatigue strength improvement methods

2.1 General

2.1.1 In general, the presence of a weld or a bonded joint in a structural component represents a possible weakness with regard to both brittle fracture and fatigue life. The low fatigue life of welded details can be considered as a limiting factor for the design of more efficient structures, in particular, since the fatigue strength of steel and aluminium materials does not increase with the yield strength.

2.1.2 Upgrading of the fatigue life of a structural detail can be achieved in a number of ways as follows:

Design Stage

- By adopting good detail design configuration, i.e., by the provision of soft connections, the geometrical stress concentration factor due to the geometrical discontinuity may be reduced to a satisfactory level.
- By increasing the local scantlings, in particular those of the plate in which the potential crack sites are located, to reduce the local hot spot stresses.
- By modifying the structural load path and/or reducing the structural load level by the provision of additional load carrying members.

Fabrication Stage

- By improving the fatigue life of the detail by using an improvement method.

2.1.3 It is LR's intention to promote the Design Stage method for fatigue strength improvement of a craft's structural details. Fabrication stage improvement methods should only be considered as remedial measures, and subjected to strict quality control procedures. Where a fabrication stage improvement method is planned at the design stage, it is to be specially considered by LR to ensure that a satisfactory level of fatigue strength improvement is achieved.

2.2 Significant variables affecting fatigue strength improvement methods

2.2.1 The significant variables affecting the fatigue strength of a craft's structural details are reviewed:

- The geometrical notch at the weld toe region is normally the most fatigue critical area. Welded joints inherently contain a number of defects, most of which are so sharp that they start growing as fatigue cracks when the structure is subjected to dynamic loads, thus eliminating the crack initiation stage of the fatigue life.
- The fatigue crack is most likely to initiate and propagate in the Heat Affected Zone (HAZ) region, since local metallurgical changes may affect the local fatigue properties of the material, and defects are usually concentrated in this area.
- Residual stresses are set up in and near the weld due to the contraction of the weld metal during the cooling phase. These local residual stresses due to welding may reach yield stress magnitude, and affect the fatigue properties in a similar manner to externally imposed loads. Tensile residual stresses tend to reduce the fatigue strength, while compressive residual stresses may improve the fatigue strength. Attention to residual stresses is not only limited to the welding process, residual stresses may arise due to the restraints applied to the prefabricated units, the forcing of the prefabricated units during assembly, or uneven thermal expansion creating long range residual stresses acting over large areas. These long range residual stresses tend not to be relaxed by the occurrence of peak loads resulting in the so called shakedown process, or local treatment of the structural detail. However, they are generally of small magnitude compared to welding residual stresses.

2.3 Design stage fatigue strength improvement methods

2.3.1 It is clear that the most efficient method to improve the fatigue strength of welded structural details is at the design stage. To this effect, there are four factors which need to be specially considered to improve the fatigue strength of ship structural details as follows:

- Nominal stress level.
- Geometrical stress concentration due to the structural detail geometry.
- Weld geometry and construction tolerances.
- Residual stresses and construction procedure.

Each item outlined above is presented in the following Sections.

2.3.2 **Nominal stress level.** The most efficient way to improve fatigue strength is to increase the local scantling to reduce the nominal stress level, and hence the hot spot stress for a given structural detail. In general, structural details on higher tensile steel and aluminium require improvement in detail design over the mild steel and the base grade aluminium equivalent structural detail by virtue of the higher stress level and the constant fatigue strength for material of various yield strength. The advantages and disadvantages of this fatigue strength improvement method are summarised in Table 2.3.1.

Table 2.3.1 Nominal stress level

Advantages	Disadvantages
<ul style="list-style-type: none"> • Reduce stress level • Increase static strength • Potential decrease in number of structural components and/or complexity required over that for a structural detail in higher tensile strength material 	<ul style="list-style-type: none"> • Increase structure weight

2.3.3 **Geometrical stress concentration.** The adoption of a good detail design configuration by the provision of soft connections reduces the geometrical stress concentration factor due to the geometrical discontinuity to a satisfactory level. Typical detail design improvements for the critical areas are provided in Chapters 4 and 5 of these Guidance Notes for steel/aluminium alloy and composite construction respectively. These detail design improvements have been developed from the consolidation of service experience and finite element analysis. The advantages and disadvantages of the subject fatigue improvement method are summarised in Table 2.3.2.

Guidance for Designers for Steel/Aluminium Construction

Chapter 2

Section 2

Table 2.3.2 Geometrical stress concentration

Advantages	Disadvantages
<ul style="list-style-type: none"> Reduce hot spot stress level by reducing the local geometrical stress concentration Most effective fatigue strength improvement technique May provide additional structural redundancy 	<ul style="list-style-type: none"> May increase structural weight if additional pieces are required Requires good workmanship where soft toe/heel are required

2.3.4 Weld geometry and construction tolerances. At the design stage, special attention may be given to achieving a favourable geometry and smooth transition at the weld toe, and minimising secondary stress concentration which may arise from the fit up and misalignment. Since the weld notch stress concentration is a direct function of the weld flank angle and the weld toe radius, critical structural details may be specified with an enhanced weld procedure and construction tolerances.

In view of the size and hull form of special service craft, additional considerations must, in general, be given to the accessibility for welding. This should include the selection of the depth, geometry and orientation of the stiffening members to provide the necessary access to carry out the required welding sequences, with the type and size of welding equipment available to the Builder.

The advantages and disadvantages of the subject fatigue improvement method are summarised in Table 2.3.3.

Table 2.3.3 Weld geometry and construction tolerances

Advantages	Disadvantages
<ul style="list-style-type: none"> The improvement may be introduced at the design stage The improvement is performed in the welding process itself Subject to well defined inspection plan and hence higher reliability 	<ul style="list-style-type: none"> Improvement can be subject to large scatter if not controlled under QA survey conditions i.e., Fatigue Control Plan

2.3.5 Residual stresses, and construction procedures.

The minimising of residual stresses through the adoption of appropriate welding procedures and sequences, the use of adequate unit size, and appropriate sequence of erection of the prefabrication unit do not constitute in themselves a fatigue strength improvement procedure. Nevertheless careful planning should be considered at the design stage to ensure that detrimental effects will not be introduced during the construction process.

Construction Tolerances and Defect Correction Procedures for Steel/Aluminium Construction

Chapter 3

Sections 1 & 2

Section

- 1 **Introduction**
- 2 **Construction tolerances**
- 3 **Defect correction procedures**

■ Section 1 Introduction

1.1 General

1.1.1 The fatigue life of structural details can be adversely affected by a variety of imperfections. The most common type of imperfections are:

- (a) Misalignment of structural members, poor fit-up.
- (b) Welding defects.
- (c) Material defects.
- (d) Poor manufacture and fabrication procedures resulting in stress concentrations.
- (e) Unfairness of plating.

1.1.2 The actual influence on fatigue life will depend on the number, location and size of such imperfections.

1.1.3 Where design calculations highlight regions of stress concentration then experience clearly indicates that such regions will have a higher probability of failure during the life of the craft than surrounding structures. Hence in such locations there is a need to introduce standards that will reduce or eliminate the number or type of imperfections present.

1.1.4 Basic requirements concerning welding and structural details are given in Pt 6, Ch 2 and Pt 7, Ch 2 of the Rules for Special Service Craft for steel and aluminium alloy craft respectively. The individual standards employed by Builders are normally based on individual national standards, e.g. British Standards, and these supplement the Rule requirements.

1.1.5 Construction and erection criteria in accordance with such standards must inevitably be taken into account in the fatigue life calculation for any structural detail. Whilst it may be anticipated that such criteria may, in general, in association with an acceptable detail arrangement, provide for adequate fatigue life, there may well be instances where there is a specific need to introduce construction tolerances that are more rigorous.

1.1.6 The LR Surveyors will be required to confirm that the work is carried out in accordance with the approved construction tolerances. Where the approved tolerances are exceeded then corrective action to the satisfaction of the Surveyor will be required. Details of the construction tolerances and defect correction procedures to be applied are indicated in Pt 3, Ch 1 of the Rules for Special Service Craft.

■ Section 2 Construction tolerances

2.1 General

2.1.1 Construction tolerances are to comply with Pt 3, Ch 1 of the Rules for Special Service Craft. The additional guidance given in this Chapter should also be complied with where practicable.

2.2 Defects in steel/aluminium products

2.2.1 Where defects are found in materials after delivery to the Builder, any rectification should be agreed with the LR Surveyor and should generally be in accordance with Ch 3,1.11 or Ch 8,1.10 of the Rules for Materials and aluminium respectively.

2.2.2 If lamination is found during plate preparation the extent of the lamination should be ascertained by ultrasonic examination. Renewal of the affected material is normally recommended.

2.3 Construction standards

2.3.1 Construction standards (including preparation of material, joint alignment, type of welded joint, fit-up prior to welding, steps to be taken for rectification of defects, etc.) are to be agreed between LR and the Builder. Such standards will be recorded and kept on file by LR. In a number of countries national standards exist in respect of the acceptable ship-building standards.

2.3.2 In shipyards certified under the LR Quality Assurance Scheme, the standards will have received general approval as part of the certification procedures and their application to particular craft will be included in the quality plan submitted to LR for approval.

2.3.3 In considering critical locations and their construction standards it also has to be borne in mind that craft construction is a traditional process with alignment standards based on heel lines. In addition, therefore, to establishing the more critical joints in terms of fatigue life, consideration of the thicknesses to be employed in these joints should be a fundamental factor. If the heel line principle is maintained at the toes of, for example, primary member end brackets, where increased thicknesses are employed, the arrangements will in reality, be out of line, even though perfect alignment is attained to the standard, see Fig. 3.2.1(a). It is therefore recommended, particularly for aluminium, that a median line principle is employed at this local area so that an improved alignment can be more easily attained. From LR's point of view the various thicknesses of plating at structural joints, particularly the higher stress joints, is an important consideration. In this respect the gradient of load through the through-thickness loaded plate should be controlled to a maximum of one in three, see Fig. 3.2.1(b).

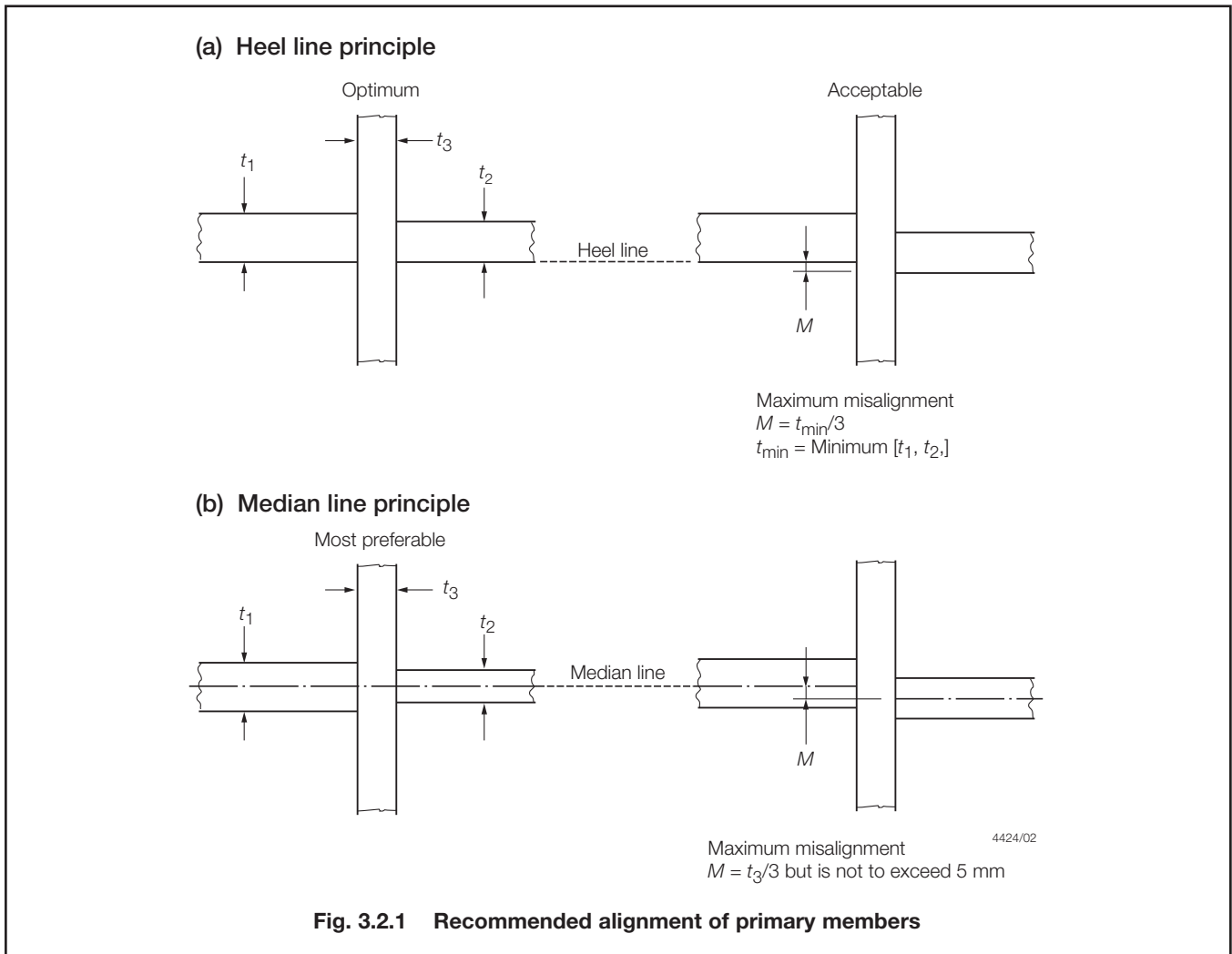

2.3.4 In addition to cruciform joint misalignment, the alignment of secondary stiffening and associated brackets is also important. Recommendations are made in Fig. 3.2.1 and Fig. 3.2.2. Where centreline alignment is recommended the tolerance guideline in Fig. 3.2.2 should be followed.

2.3.5 Whenever possible the plate thicknesses, t_1 and t_2 , (see Fig. 3.2.1) should be kept as close as possible in order to minimise the potential difficulties associated with a median line alignment.

2.4 Prefabrication

2.4.1 Throughout the preparation of material and assembly of prefabrication units, the workmanship is to be inspected in order to ensure that correct procedures are being followed. By attention in the early stages of construction, undesirable procedures and faulty workmanship can be avoided, or their consequences minimised. When the existence of such defects is noticed prompt and suitable measures are to be taken for rectification.

2.4.2 Examination of structure will normally be carried out during the prefabrication of units, and liaison between the LR Surveyor and the Builder's drawing offices and quality control departments will ensure that attention is also given to details which may not have been included on approved plans (air and drainage holes, etc.) during early material preparation stages.

2.4.3 It should be borne in mind that visual examination of welds and plating of a finished structure does not necessarily ensure a complete and satisfactory survey. Procedures are to be such as to ensure that adequate inspection is made of joint preparation before welding. Attention is drawn to the guidance on welding and structural details in Pt 6, Ch 2 and Pt 7, Ch 2 of the Rules for Special Service Craft for steel and aluminium alloy craft respectively. Regular examination by the LR Surveyor, in conjunction with the Builder, of non-destructive examination and other Quality records provides a check on the quality of welding operations and any decline in standards should be investigated, including additional tests as considered desirable.

2.4.4 It is essential that a good standard of cleaning be achieved for these inspections. Special attention, as indicated in Pt 7, Ch 2,3.11.5 of the Rules for Special Service Craft, are to be applied for aluminium. For steel structures welding slag should be removed and rusting of weld deposits should be removed by wire brushing.

Construction Tolerances and Defect Correction Procedures for Steel/Aluminium Construction

Chapter 3

Sections 2 & 3

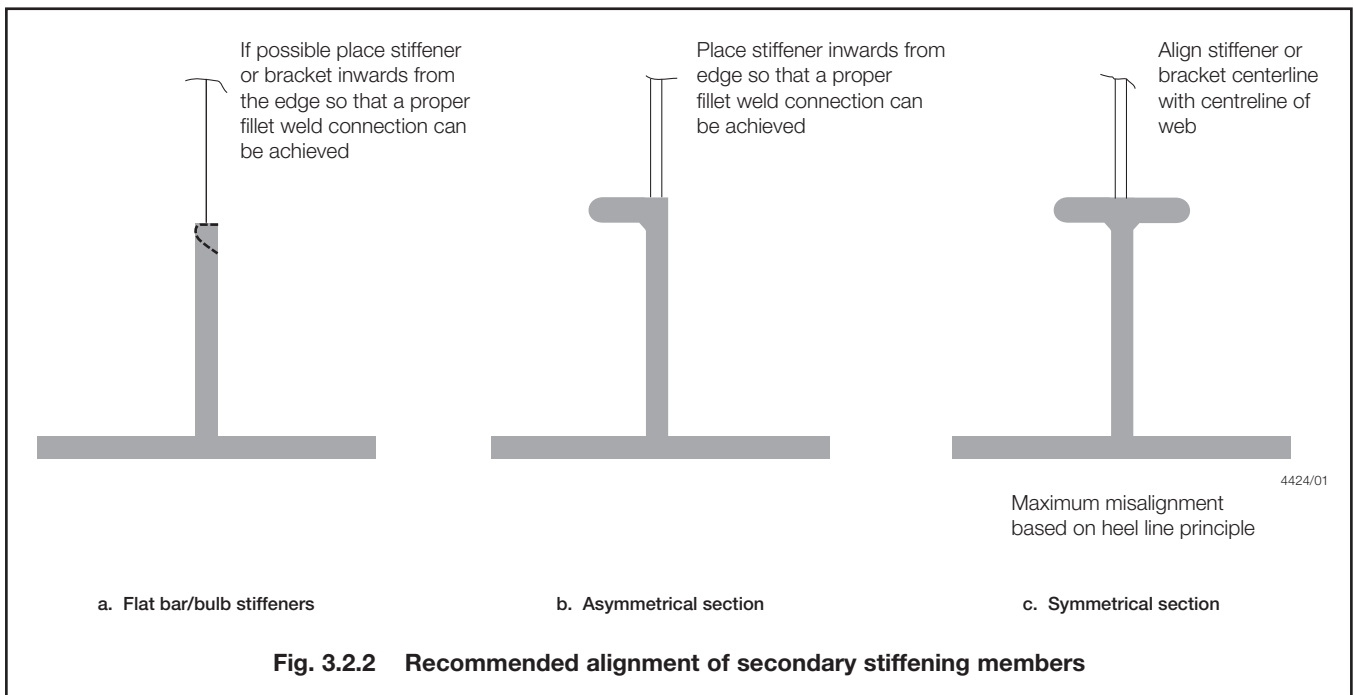

2.5 Assembly of units

2.5.1 The Builder and the LR Surveyors must ensure by regular and systematic examination that the control exercised up to the stage of block assembly is maintained by the efficient erection of blocks at the berth. It is particularly necessary at this point to ensure that fit-up, alignment, adjustment and welding of blocks is in accordance with the approved plans and building standards. Attention is to be given to the sequence of erection and of welding. Particular attention should be given to length allowance for unwelded stiffening member alignment.

2.5.2 With the assembly of large blocks careful attention should be paid to the areas in way of lifting lugs. It is not unusual to find small cracks in the vicinity of the weld area after removal of lugs. Where lugs are removed the dressing of the plate must be thorough and examination by means of crack detection of the finished surface is good practice. Repair of any cracks found must be carried out by skilled welders under strict control.

2.5.3 Any unusual incidents during construction, such as fracturing of plates, should be noted and brought to the attention of the LR Surveyor. It will be necessary to have full information on the circumstances affecting such cases, such as position and extent of the fracture relative to adjacent structure and welds, atmospheric temperature, details of joints, precise stage and sequence of welding, type of electrode filler wire used, whether or not pre-heating was used, grades of steel or aluminium alloy involved and any other factors considered to have had a possible influence. Test details of affected plates and proposals for remedial measures should also be made available. Where doubt exists in establishing the source of such incidents, the assistance of LR's staff at Headquarters, should be sought.

Section 3

Defect correction procedures

3.1 Inspection and testing

3.1.1 The fabrication specification should state the extent of visual inspection and non-destructive examination along with details of the techniques and the appropriate acceptance criteria.

3.1.2 All non-destructive examination should be in accordance with written procedures. (See also Pt 6, Ch 2 and Pt 7, Ch 2 of the Rules for Special Service Craft for steel and aluminium craft respectively.)

3.1.3 Quality control levels for weld flaws found by radiographs, ultrasonic testing, magnetic particle and dye penetrant inspection, as appropriate, are to be approved by LR and shall be imposed during fabrication as a means of quality control.

3.1.4 Welded joints critical to the integrity of the structure should be subjected to radiographic examination and/or, where applicable, surface examination during construction. This non-destructive examination should be carried out prior to delivery, after the completion of welding and prior to any coating which would adversely effect the type of non-destructive examination being undertaken. Any repairs resulting from the testing are to be re-examined.

3.1.5 Any necessary repairs and corrective actions are to be carried out to the satisfaction of the LR Surveyor and in accordance with an agreed procedure.

Section

- 1 **Identification of critical areas**
- 2 **Structural details**

■ Section 1 Identification of critical areas

1.1 General

1.1.1 LR has applied direct calculation procedures in the structural appraisal and approval of new buildings and in various investigations on special service craft of both steel and aluminium alloy construction. Through these procedures and the wealth of information collected on the LR fleet database, a number of locations have been identified where good design, workmanship and alignment during construction are particularly important. These are usually locations where high stress variations can be experienced during the lifetime of the craft. These are referred to as **critical locations** and are highlighted in this Chapter.

1.1.2 This Chapter identifies the **critical areas** within various structural elements of the hull structure and transverse bulkheads.

1.1.3 In Section 2 the structural **detail design improvements** that can be applied to increase the fatigue life of the structural components are provided. These detail improvements are intended to give the designer guidance for meeting the design criteria for structural detail components.

1.1.4 The application of 2 and 3-dimensional finite element analyses techniques to the hull structure enables the global and local capabilities of the hull structure to withstand static and dynamic loadings to be assessed. Such analyses will enable those high stress locations and joints within the craft to be readily identified. Such locations will then, by their very nature, be at risk to fatigue damage unless appropriate measures are taken at the design stage and subsequently during construction.

1.1.5 Extensive 'in service' experience of the performance of existing craft structures, already provide an awareness of those critical locations which merit particular attention either due to stress or alignment difficulties.

1.2 Critical areas

1.2.1 Stress concentrations occur in both the primary and secondary structures of all craft and are identified during the design process by such means as finite element calculations. The designer will modify the detail to alleviate the stress concentration either by redesign or increase in scantlings. However, even after modification that area will still, in general, be exposed throughout the life of the craft to stresses higher than in surrounding areas.

1.2.2 At the design appraisal stage, a plan of the structure should, where appropriate, be prepared indicating by the Builder or designer these regions, and consideration can then be given, by the production team, into the appropriate methods of construction and the tolerances to be applied in order to remain within the assigned design parameters.

1.3 Misalignment during construction

1.3.1 The very nature of steel/aluminium construction requires the assembly of a multitude of structural components into blocks within an assembly shop and then the erection of these blocks within a building dock or on a building berth. The welded interface between structural components in sub-assembly areas can be reasonably controlled; however, the welded connections between large prefabricated blocks in the building dock or on the building berth cannot be so easily controlled due to the sheer size of the blocks being handled.

1.3.2 The most critical type of joint is the welded cruciform joint where it is subjected to high magnitudes of tensile stress normal to the table member of the joint. The double bottom construction lends itself to the block construction. The interfaces between these blocks and those formed by the primary transverse structure may lie in areas of high stress. Critical cruciform joints are also found within the prefabricated blocks and also require close attention to alignment, but this is more easily achieved.

1.3.3 It can readily be seen that the combination of stress concentration and misalignment is to be avoided if the fatigue strength is to be satisfactory during the service life of the craft.

1.4 Fatigue considerations

1.4.1 The bottom shell area of high speed craft is subjected to the highest cyclic loading throughout the life of such craft.

1.4.2 The fatigue fractures in bottom longitudinal end-connections of higher tensile steel and aluminium alloy has been well documented, and constructional details in way of these connections, designed to increase fatigue life, are now incorporated by many Builders as standard. It is, therefore, important that due consideration be given to this detail at the design stage to reduce the risk of fatigue cracking during service.

1.4.3 Detailed recommendations are given herein for the critical areas, see Section 2.

■ Section 2 Structural details

2.1 Detail design improvement

2.1.1 For the purposes of these Guidance Notes, structural locations have been divided into three separate groups, with a series of examples of critical structural areas together with alternative associated detail design improvements.

2.1.2 A summary of the data presented is given in Table 4.2.1 whilst the full details are given in Figs. 1 to 29 as contained in this Section.

2.1.3 Generally, where alternative structural detail design improvements are provided, the details shown will provide improved fatigue strength.

2.1.4 Where asymmetrical sections are shown, the same requirements apply to bulb plate stiffeners and flat bars.

Detail Design Improvement for Steel/Aluminium Construction

Chapter 4

Section 2

Table 4.2.1

Group	Application	Area	Item	Fig. No
High speed craft				
1		Hull structure	Chine to frame connection	1
		Hull structure	Chine and chine bar details (1)	2
		Hull structure	Chine and chine bar details (2)	3
		Hull internal structure	Frame to beam connection (radiused)	4
		Hull internal structure	Frame to beam connection (continuous bracket)	5
		Hull internal structure	Lug connections between secondary stiffeners and primary stiffener webs (1)	6
		Hull internal structure	Lug connections between secondary stiffeners and primary stiffener webs (2)	7
		Watertight/oiltight bulkheads	Shell longitudinals collared, brackets aligned	8
		Watertight/oiltight bulkheads	Shell longitudinal (fitted brackets)	9
		Watertight/oiltight bulkheads with boundary bar	Shell longitudinal (fitted brackets)	10
		Watertight/oiltight bulkheads	Collar inserts in way of secondary stiffening members	11
		Watertight/oiltight bulkheads	Collar inserts in way of primary stiffening members	12
		Cross-deck structure, multi-hulls	Inner side web frame to deck transverse connection	13
		Cross-deck structure	Deck transverse to watertight bulkhead connection	14
		Multi-hull structure	Cross-deck beam to bulkhead connection	15
Low speed craft				
2		Hull internal structure	Floor to frame connection (bracketed)	16
		Hull internal structure	Frame to beam connection	17
		Watertight/oiltight bulkheads with boundary bar	Shell longitudinals (lapped brackets)	18
		Watertight/oiltight bulkheads	Shell longitudinals (lapped brackets)	19
		Watertight/oiltight bulkheads	Shell longitudinals collared, brackets lapped	20
		Cross-deck structure, multi-hulls	Connection between cross-deck beams and side hulls	21
General detail				
3		Cross-deck structure, multi-hulls	Connection between cross-deck beams and side hulls	22
		Hull centreline structure	Bar and plate keels	23
		Hull centreline structure	Bar keels	24
		Hull centreline structure	Fabricated plate keel/skeg	25
		Hull centreline structure	Round bar and flat bar stems	26
		Hull centreline structure	Fabricated and plate stems	27
		Hull internal structure	Floors to frame connection (radiused)	28
		Hull internal structure	Web frame to tank boundary connection	29

Detail Design Improvement for Steel/Aluminium Construction

Chapter 4

Section 2

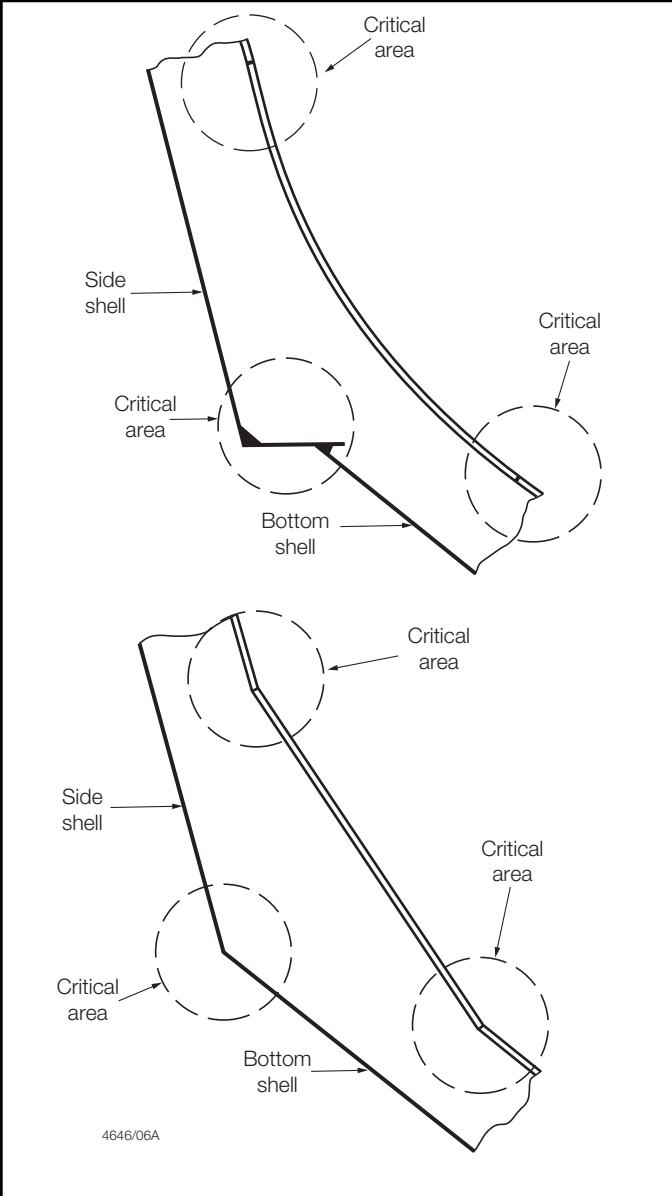
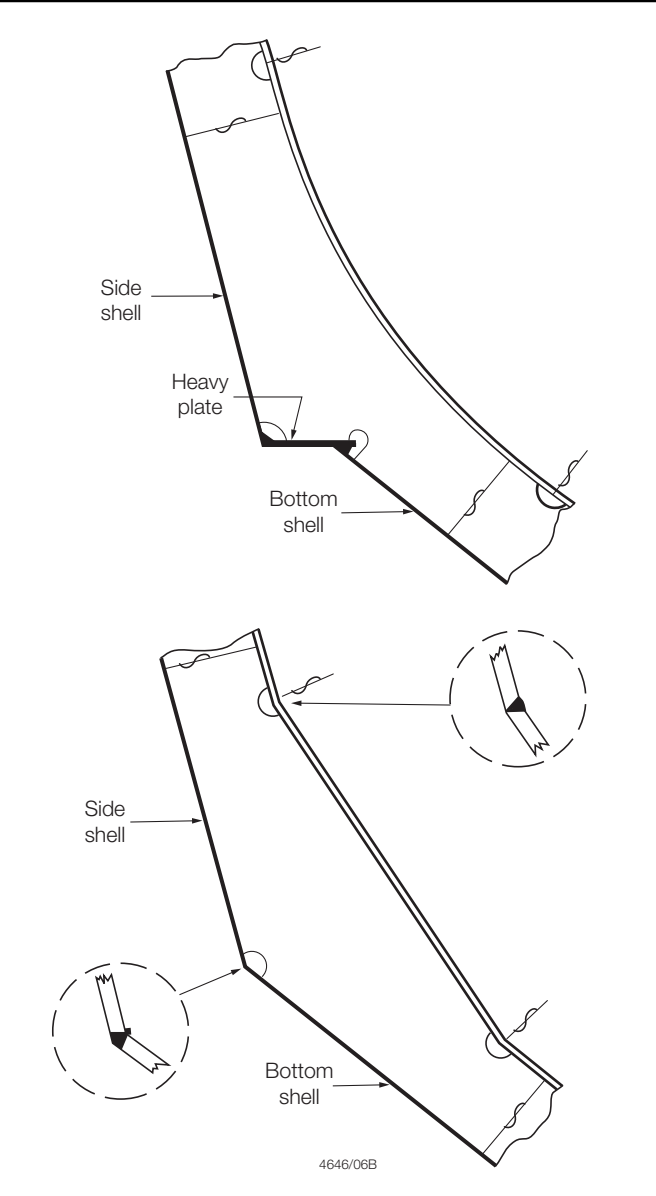
AREA: Hull structure ITEM: Chine to frame connection		
CRITICAL AREAS	DETAIL DESIGN IMPROVEMENT	
 <p>4646/06A</p>		 <p>4646/06B</p>
NOTES Failure Mechanism Fatigue fractures from areas of tri-axial stress. Building Tolerance To be in accordance with Pt 3, Ch 1 of the Rules for Special Service Craft. Welding Requirements To be in accordance with Pt 6, Ch 2 and Pt 7, Ch 2 of the Rules for Special Service Craft, for steel and aluminium alloy craft respectively. All welding between chine bars and shell plating is to be full penetration type. Butts in web plating and face flats are to be staggered.		
GROUP 1	GUIDANCE NOTES FOR DESIGN DETAILS STEEL/ALUMINIUM CONSTRUCTION	FIGURE 1

Detail Design Improvement for Steel/Aluminium Construction

Chapter 4

Section 2



AREA: Hull structure
 ITEM: Chine and chine bar details (1)

CRITICAL AREAS

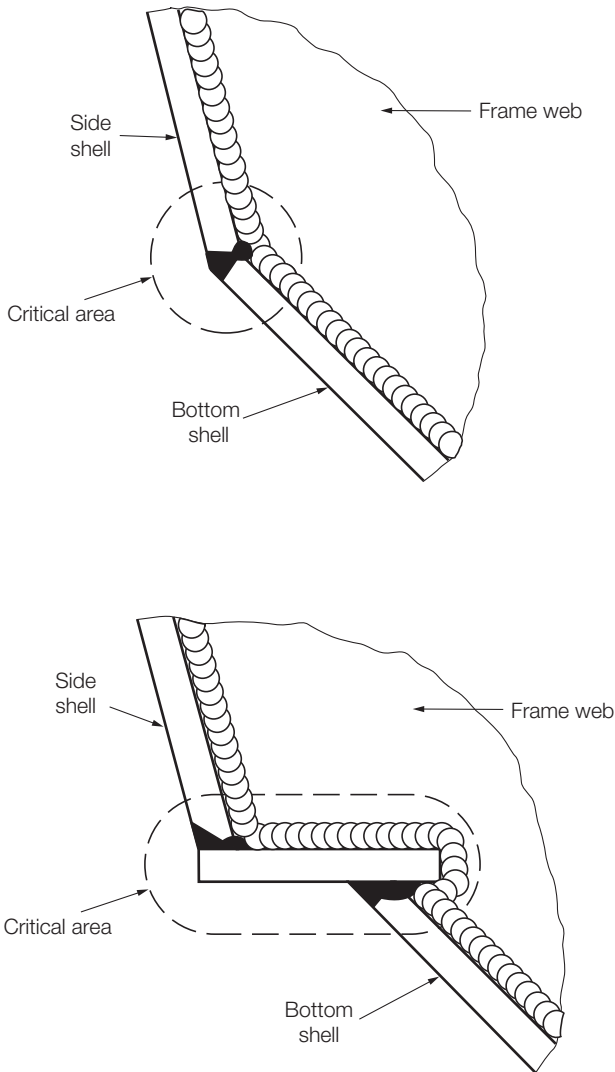

4646/07A

DETAIL DESIGN IMPROVEMENT

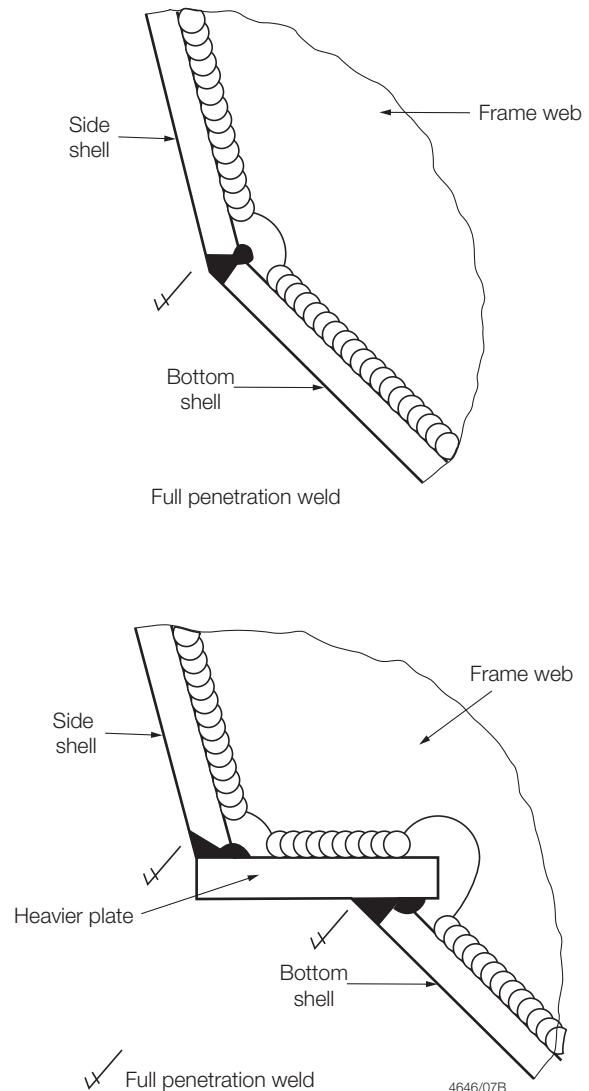

4646/07B

NOTES

- Failure Mechanism: Fatigue fractures from areas of tri-axial stress.
- Building Tolerance: To be in accordance with Pt 3, Ch 1 of the Rules for Special Service Craft.
- Welding Requirements: To be in accordance with Pt 6, Ch 2 and Pt 7, Ch 2 of the Rules for Special Service Craft, for steel and aluminium alloy craft respectively. All welding in way of shell plating and between chine bar and shell plating is to be full penetration type. Welds are to be returned around scallops.

GROUP
1

GUIDANCE NOTES FOR DESIGN DETAILS
STEEL/ALUMINIUM CONSTRUCTION

FIGURE
2

Detail Design Improvement for Steel/Aluminium Construction

Chapter 4

Section 2

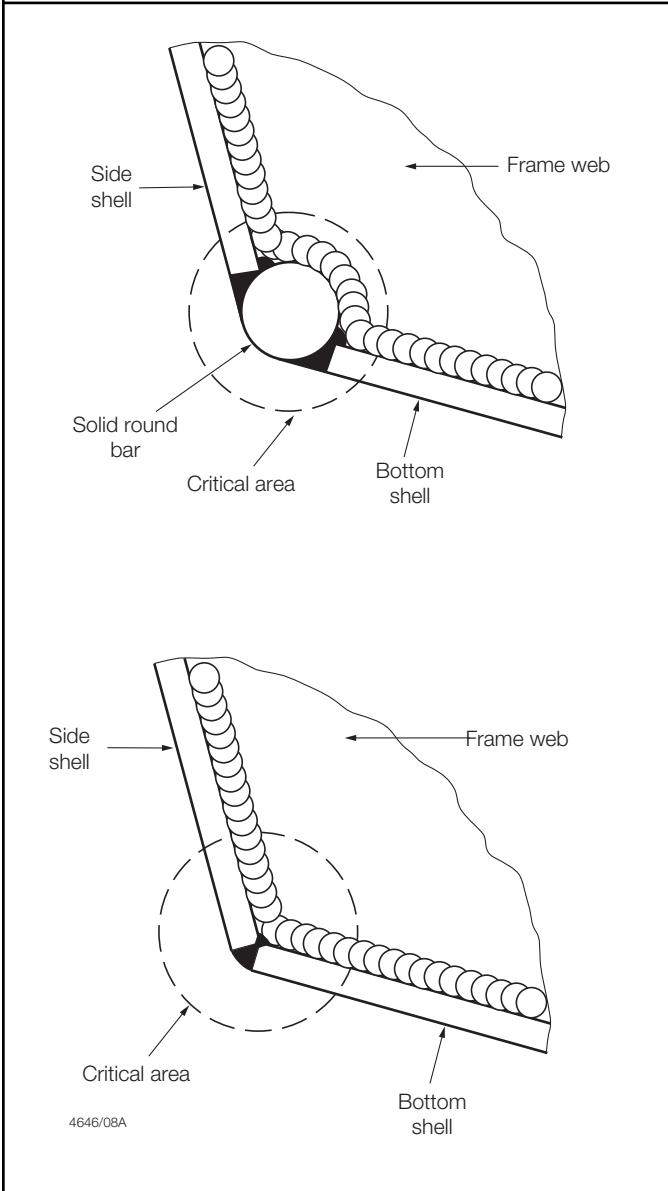
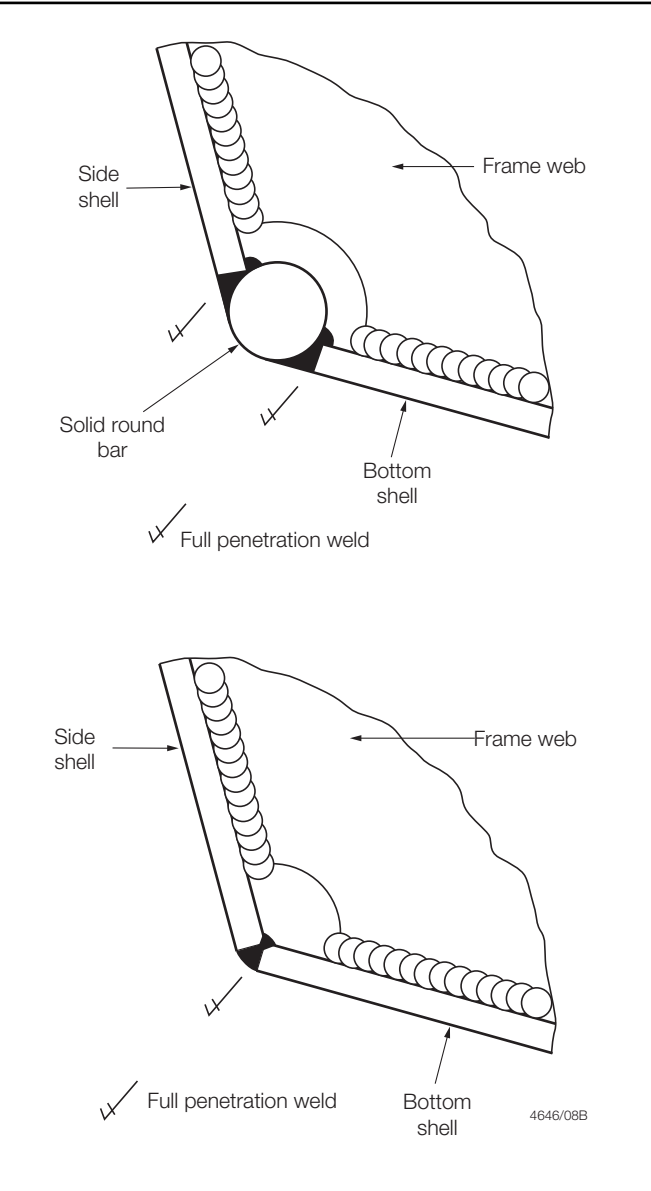
AREA: Hull structure ITEM: Chine and chine bar details (2)		
CRITICAL AREAS	DETAIL DESIGN IMPROVEMENT	
		
NOTES Failure Mechanism Fatigue fractures from areas of tri-axial stress. Building Tolerance To be in accordance with Pt 3, Ch 1 of the Rules for Special Service Craft. Welding Requirements To be in accordance with Pt 6, Ch 2 and Pt 7, Ch 2 of the Rules for Special Service Craft, for steel and aluminium alloy craft respectively. All welding in way of shell plating and between chine bar and shell plating is to be full penetration type. Welds to be returned around scallops.		
GROUP 1	GUIDANCE NOTES FOR DESIGN DETAILS STEEL/ALUMINIUM CONSTRUCTION	FIGURE 3

Detail Design Improvement for Steel/Aluminium Construction

Chapter 4

Section 2

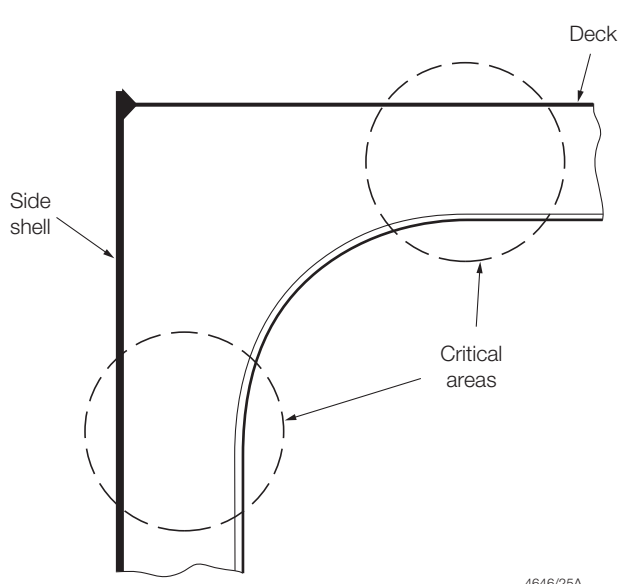
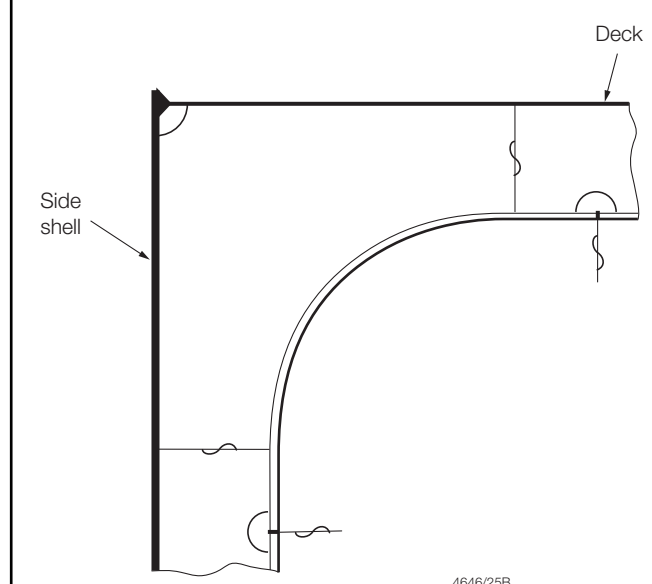
AREA: Hull internal structure ITEM: Frame to beam connection (radiused)					
CRITICAL AREAS	DETAIL DESIGN IMPROVEMENT				
 <p style="text-align: right;">4646/25A</p>			 <p style="text-align: right;">4646/25B</p>		
NOTES Failure Mechanism Fatigue fractures in way of welds. Building Tolerance To be in accordance with Pt 3, Ch 1 of the Rules for Special Service Craft. Welding Requirements To be in accordance with Pt 6, Ch 2 and Pt 7, Ch 2 of the Rules for Special Service Craft, for steel and aluminium alloy craft respectively. Webs to be accurately aligned. Butts in webs are to be staggered from the butts in face flats. All welds to be returned around scallops.					
GROUP 1	GUIDANCE NOTES FOR DESIGN DETAILS STEEL/ALUMINIUM CONSTRUCTION	FIGURE 4			

Detail Design Improvement for Steel/Aluminium Construction

Chapter 4

Section 2

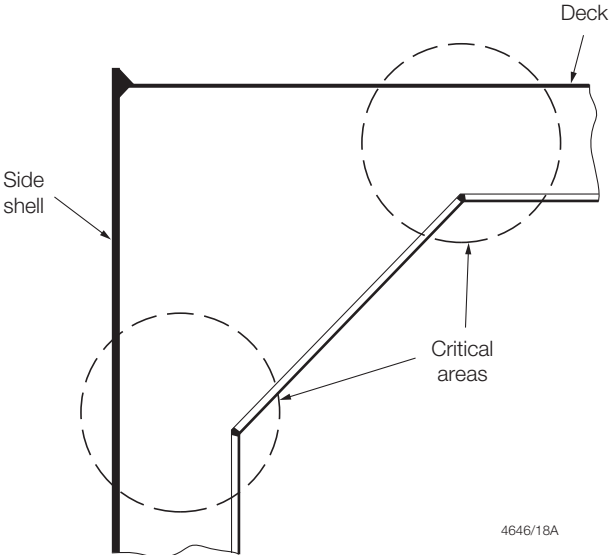
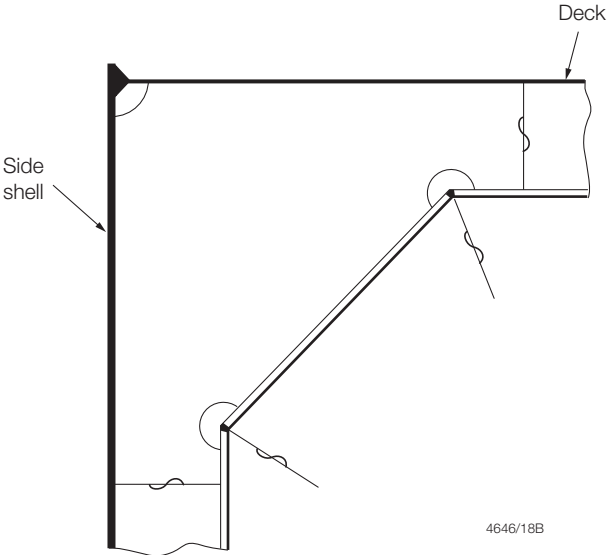
AREA: Hull internal structure ITEM: Frame to beam connection (continuous bracket)		
CRITICAL AREAS	DETAIL DESIGN IMPROVEMENT	
 <p style="text-align: right;">4646/18A</p>	 <p style="text-align: right;">4646/18B</p>	
NOTES Failure Mechanism Fatigue fractures in way of welds. Building Tolerance To be in accordance with Pt 3, Ch 1 of the Rules for Special Service Craft. Welding Requirements To be in accordance with Pt 6, Ch 2 and Pt 7, Ch 2 of the Rules for Special Service Craft, for steel and aluminium alloy craft respectively. Webs to be carefully aligned. Butts in webs are to be staggered from the butts in face flats. All welds to be returned around scallops.		
GROUP 1	GUIDANCE NOTES FOR DESIGN DETAILS STEEL/ALUMINIUM CONSTRUCTION	FIGURE 5

Detail Design Improvement for Steel/Aluminium Construction

Chapter 4

Section 2

AREA:	Hull internal structure	 Lloyd's Register
ITEM:	Lug connections between secondary stiffeners and primary stiffener webs (1)	

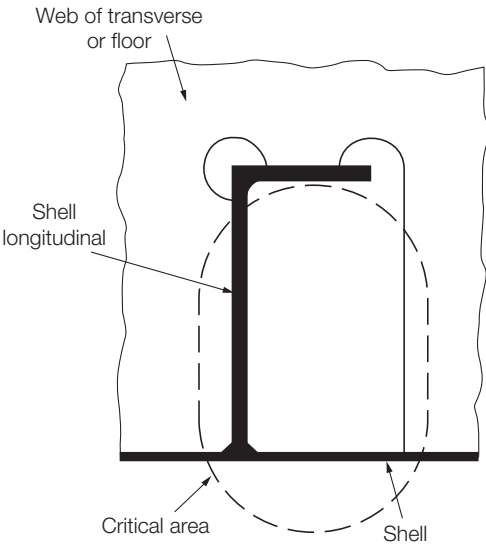
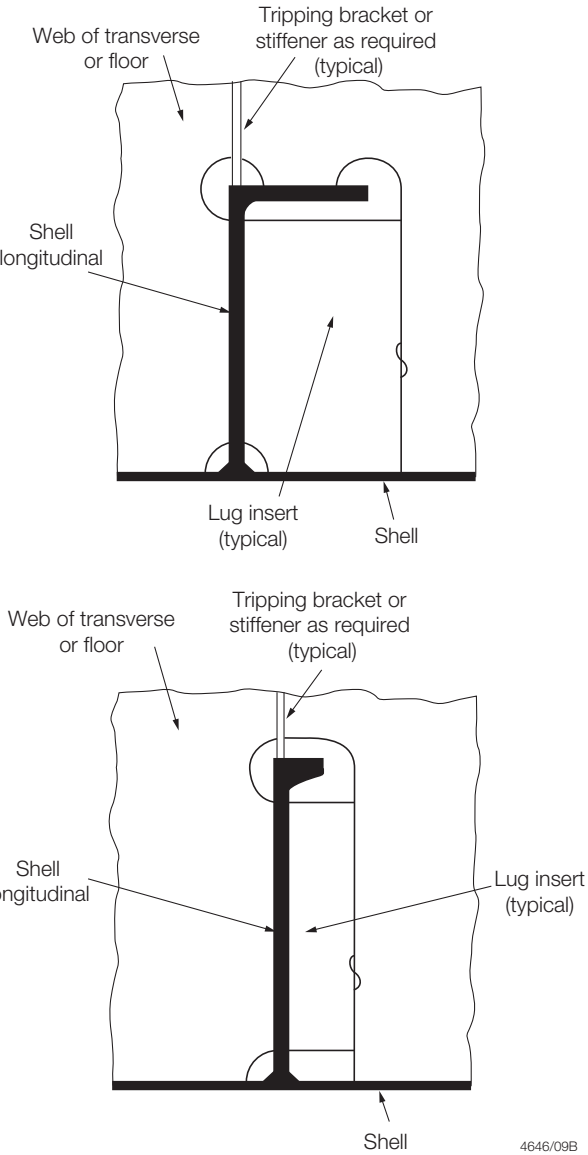
CRITICAL AREAS	DETAIL DESIGN IMPROVEMENT
 4646/09A	 4646/09B

NOTES

Failure Mechanism	Fatigue cracking of shell plate in way of hardspot, buckling and shear failure of the web of the primary member.
Building Tolerance	To be in accordance with Pt 3, Ch 1 of the Rules for Special Service Craft.
Welding Requirements	To be in accordance with Pt 6, Ch 2 and Pt 7, Ch 2 of the Rules for Special Service Craft, for steel and aluminium alloy craft respectively. All welding in way of lugs is to be double continuous. Welds to be returned around scallops. Lug inserts to align with primary stiffener web plating or floor.

GROUP 1	GUIDANCE NOTES FOR DESIGN DETAILS STEEL/ALUMINIUM CONSTRUCTION	FIGURE 6
------------	---	-------------

Detail Design Improvement for Steel/Aluminium Construction

Chapter 4

Section 2

AREA:	Hull internal structure	 Lloyd's Register
ITEM:	Lug connections between secondary stiffeners and primary stiffener webs (2)	

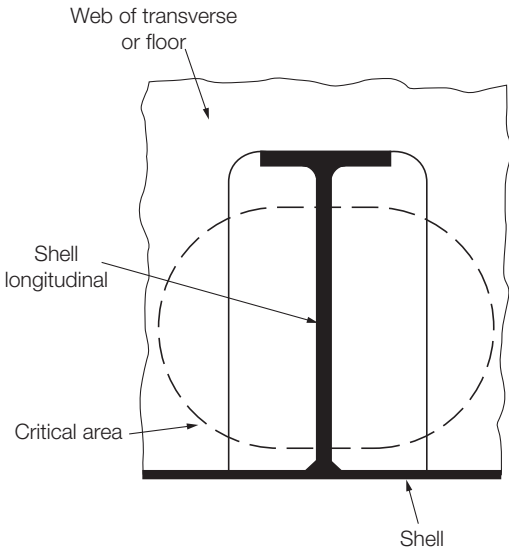
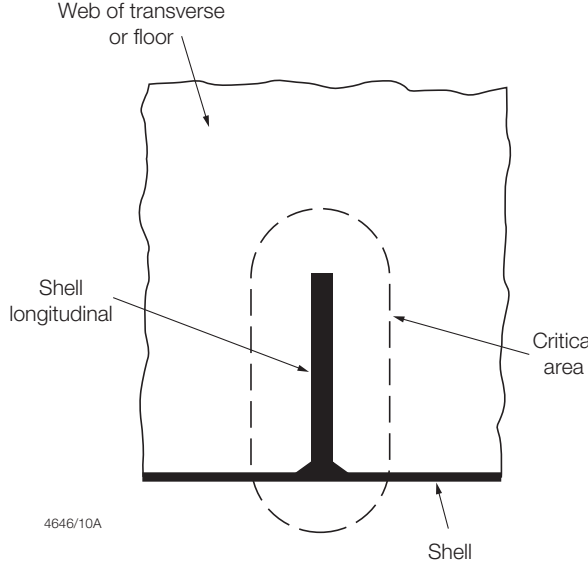
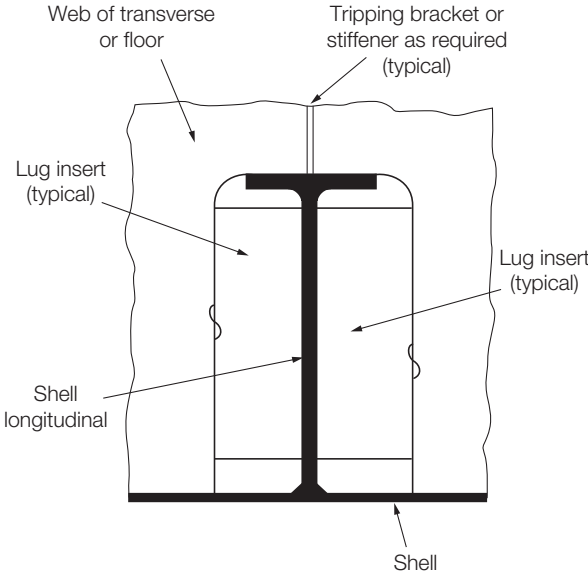
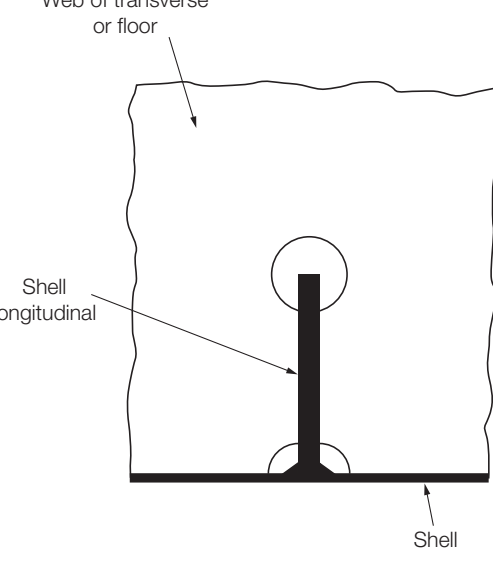
CRITICAL AREAS	DETAIL DESIGN IMPROVEMENT
  <p style="text-align: left; margin-left: 100px;">4646/10A</p>	  <p style="text-align: right; margin-right: 100px;">4646/10B</p>

NOTES	
Failure Mechanism	Fatigue cracking of shell plate in way of hardspot, buckling and shear failure of the web of the primary member.
Building Tolerance	To be in accordance with Pt 3, Ch 1 of the Rules for Special Service Craft.
Welding Requirements	To be in accordance with Pt 6, Ch 2 and Pt 7, Ch 2 of the Rules for Special Service Craft, for steel and aluminium alloy craft respectively. All welding in way of lugs is to be double continuous. Welds to be returned around scallops. Lug inserts to align with primary stiffener web plating or floor.

GROUP 1	GUIDANCE NOTES FOR DESIGN DETAILS STEEL/ALUMINIUM CONSTRUCTION	FIGURE 7
------------	---	-------------

Detail Design Improvement for Steel/Aluminium Construction

Chapter 4

Section 2

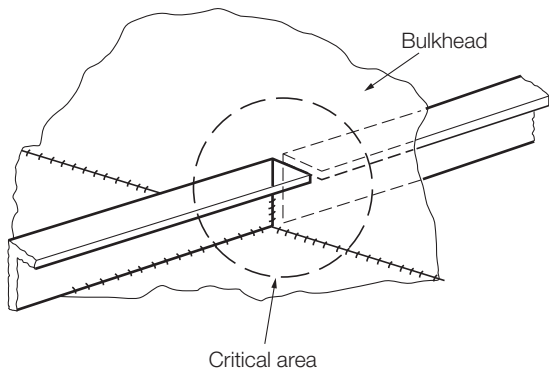
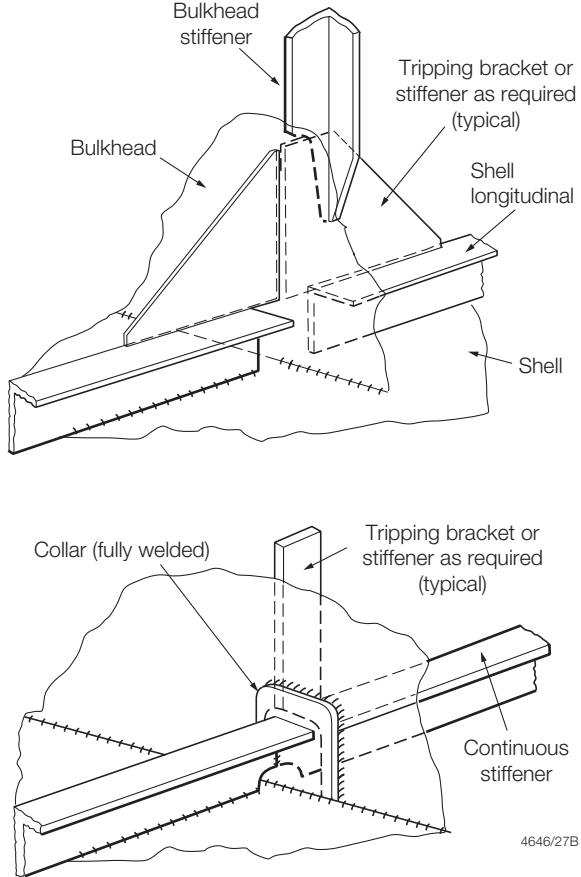
AREA: Watertight/oiltight bulkheads ITEM: Shell longitudinals collared, brackets aligned		
CRITICAL AREAS	DETAIL DESIGN IMPROVEMENT	
 <p style="text-align: center;">4646/27A</p>	 <p style="text-align: right;">4646/27B</p>	
NOTES		
Failure Mechanism Building Tolerance Welding Requirements	Fractures in bulkhead plating arising from stress concentrations in way of longitudinal stiffener end connections. To be in accordance with Pt 3, Ch 1 of the Rules for Special Service Craft. To be in accordance with Pt 6, Ch 2 and Pt 7, Ch 2 of the Rules for Special Service Craft, for steel and aluminium alloy craft respectively. All welding in way of collar and stiffener end connections is to be double continuous type. Welds to be returned around scallops.	
GROUP 1	GUIDANCE NOTES FOR DESIGN DETAILS STEEL/ALUMINIUM CONSTRUCTION	FIGURE 8

Detail Design Improvement for Steel/Aluminium Construction

Chapter 4

Section 2

AREA:	Watertight/oiltight bulkheads	
ITEM:	Shell longitudinals (fitted brackets)	

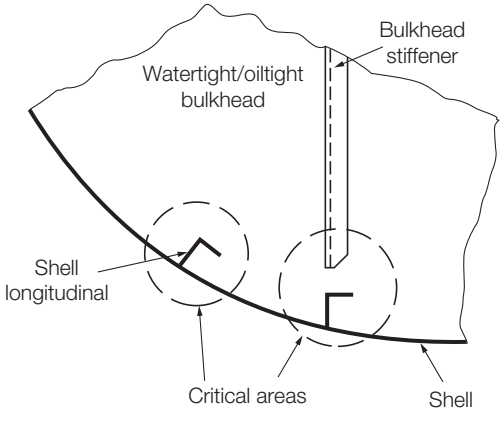
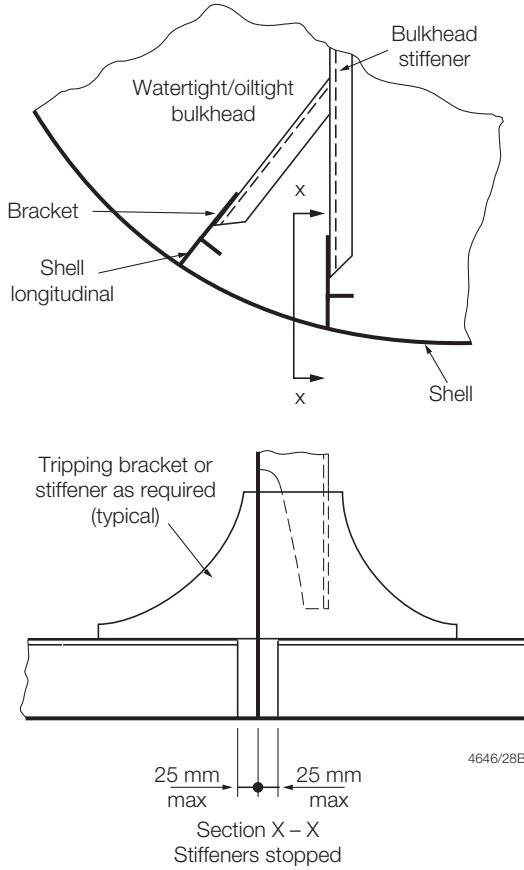
CRITICAL AREAS	DETAIL DESIGN IMPROVEMENT
 <p style="text-align: right; font-size: small;">4646/28A</p>	 <p style="text-align: right; font-size: small;">4646/28B</p>

NOTES

Failure Mechanism	Fractures in bulkhead plating arising from stress concentrations in way of longitudinal stiffener end connections.
Building Tolerance	To be in accordance with Pt 3, Ch 1 of the Rules for Special Service Craft.
Welding Requirements	To be in accordance with Pt 6, Ch 2 and Pt 7, Ch 2 of the Rules for Special Service Craft, for steel and aluminium alloy craft respectively. Webs of brackets are to be accurately aligned through the bulkhead plating and with the webs of the longitudinal stiffeners. All welding in way of brackets and stiffener end connections is to be double continuous type.

GROUP 1	GUIDANCE NOTES FOR DESIGN DETAILS STEEL/ALUMINIUM CONSTRUCTION	FIGURE 9
------------	---	-------------

Detail Design Improvement for Steel/Aluminium Construction

Chapter 4

Section 2

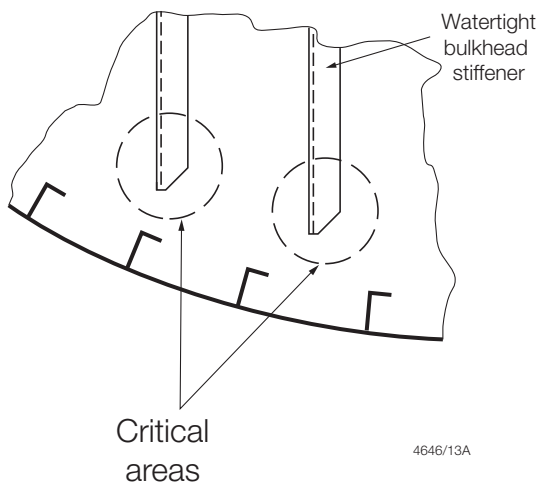
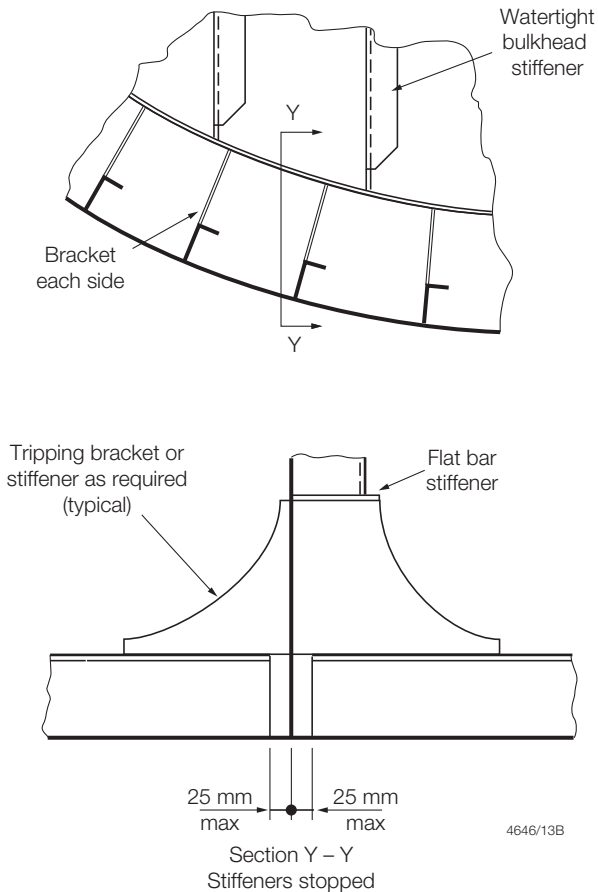
AREA: Watertight/oiltight bulkheads with boundary bar ITEM: Shell longitudinals (fitted brackets)		
CRITICAL AREAS	DETAIL DESIGN IMPROVEMENT	
		
NOTES Failure Mechanism Fractures in bulkhead plating arising from stress concentrations in way of longitudinal stiffener end connections. Building Tolerance To be in accordance with Pt 3, Ch 1 of the Rules for Special Service Craft. Welding Requirements To be in accordance with Pt 6, Ch 2 and Pt 7, Ch 2 of the Rules for Special Service Craft, for steel and aluminium alloy craft respectively. Webs of brackets are to be accurately aligned through the bulkhead plating and with the webs of the longitudinal stiffeners. All welding in way of brackets and stiffener end connections is to be double continuous type.		
GROUP 1	GUIDANCE NOTES FOR DESIGN DETAILS STEEL/ALUMINIUM CONSTRUCTION	FIGURE 10

Detail Design Improvement for Steel/Aluminium Construction

Chapter 4

Section 2

AREA:	Watertight/oiltight bulkheads	
ITEM:	Collar inserts in way of secondary stiffening members	

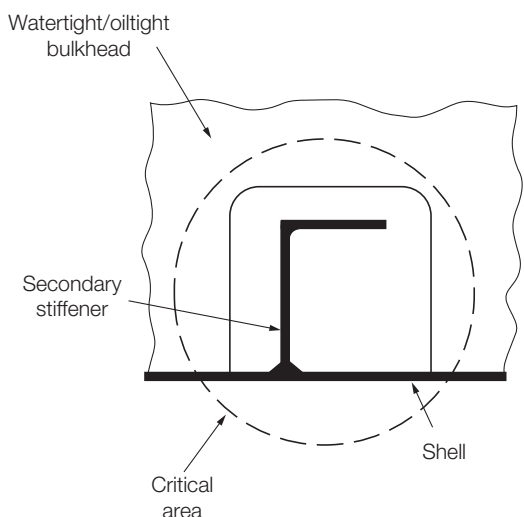
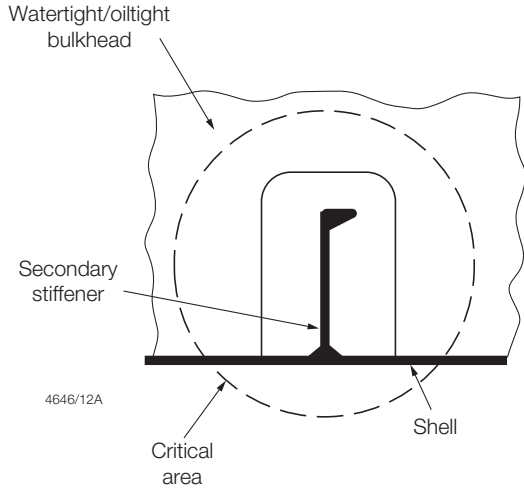
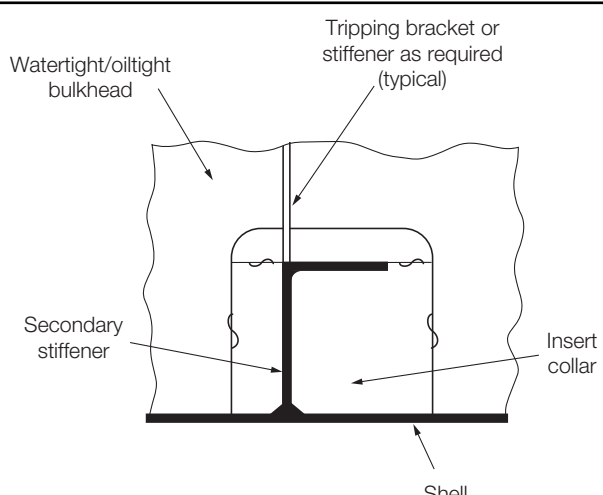
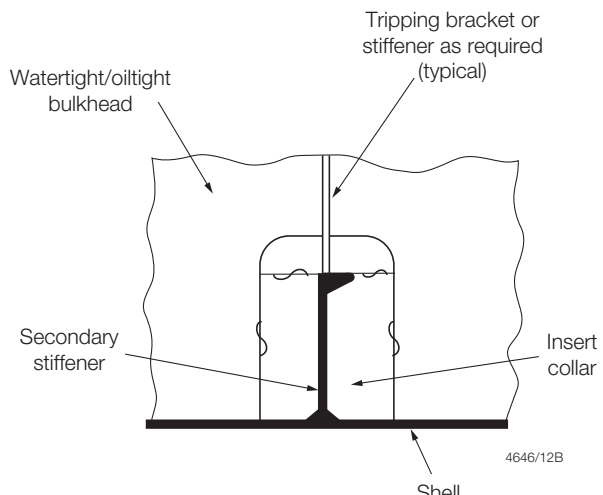
CRITICAL AREAS	DETAIL DESIGN IMPROVEMENT
 <p>Watertight/oiltight bulkhead</p> <p>Secondary stiffener</p> <p>Critical area</p> <p>Shell</p>  <p>Watertight/oiltight bulkhead</p> <p>Secondary stiffener</p> <p>Critical area</p> <p>Shell</p> <p>4646/12A</p>	 <p>Watertight/oiltight bulkhead</p> <p>Tripping bracket or stiffener as required (typical)</p> <p>Secondary stiffener</p> <p>Insert collar</p> <p>Shell</p>  <p>Watertight/oiltight bulkhead</p> <p>Tripping bracket or stiffener as required (typical)</p> <p>Secondary stiffener</p> <p>Insert collar</p> <p>Shell</p> <p>4646/12B</p>

NOTES	
Failure Mechanism	Fatigue fractures and leakage.
Building Tolerance	To be in accordance with Pt 3, Ch 1 of the Rules for Special Service Craft.
Welding Requirements	To be in accordance with Pt 6, Ch 2 and Pt 7, Ch 2 of the Rules for Special Service Craft, for steel and aluminium alloy craft respectively. Inserts to align with watertight/oiltight bulkhead plating. All welding in way of collar inserts and stiffener end connections is to be double continuous type.

GROUP 1	GUIDANCE NOTES FOR DESIGN DETAILS STEEL/ALUMINIUM CONSTRUCTION	FIGURE 11
------------	---	--------------

Detail Design Improvement for Steel/Aluminium Construction

Chapter 4

Section 2

AREA:	Watertight/oiltight bulkheads	 Lloyd's Register
ITEM:	Collar inserts in way of primary stiffening members	

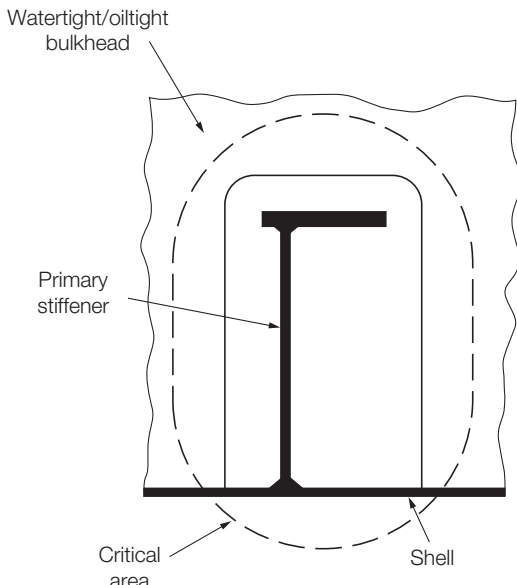
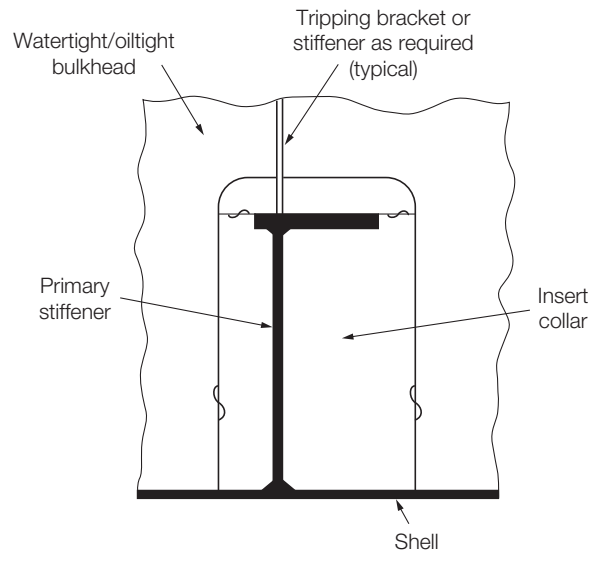
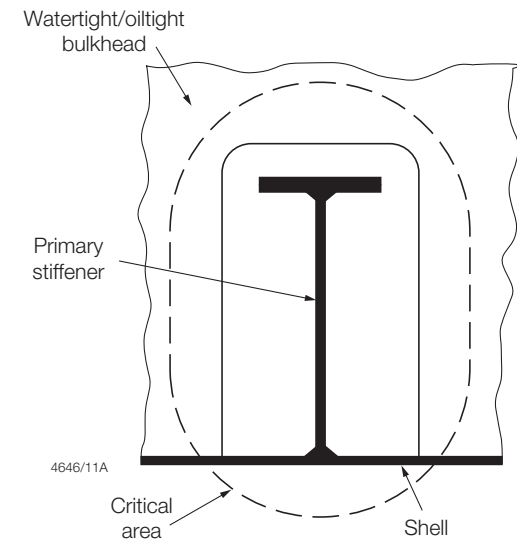
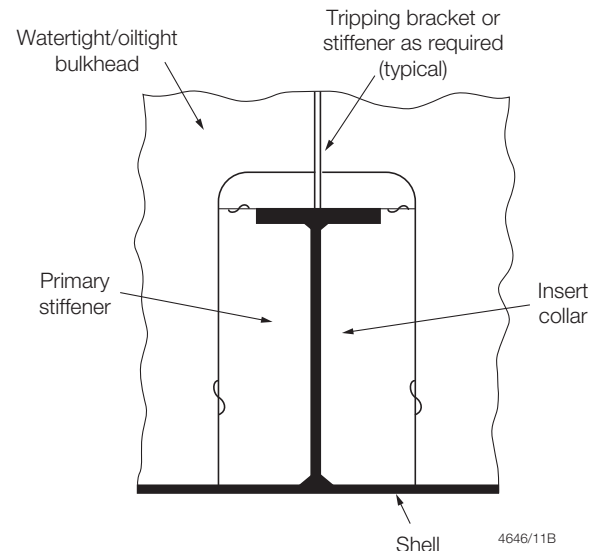
CRITICAL AREAS	DETAIL DESIGN IMPROVEMENT
 <p style="text-align: center;">4646/11A</p>	 <p style="text-align: center;">4646/11B</p>
 <p style="text-align: center;">4646/11A</p>	 <p style="text-align: center;">4646/11B</p>

NOTES	
Failure Mechanism	Fatigue fractures and leakage.
Building Tolerance	To be in accordance with Pt 3, Ch 1 of the Rules for Special Service Craft.
Welding Requirements	To be in accordance with Pt 6, Ch 2 and Pt 7, Ch 2 of the Rules for Special Service Craft, for steel and aluminium alloy craft respectively. Inserts to align with watertight/oiltight bulkhead plating. All welding in way of collar inserts and stiffener end connections is to be double continuous type.

GROUP 1	GUIDANCE NOTES FOR DESIGN DETAILS STEEL/ALUMINIUM CONSTRUCTION	FIGURE 12
------------	---	--------------

Detail Design Improvement for Steel/Aluminium Construction

Chapter 4

Section 2

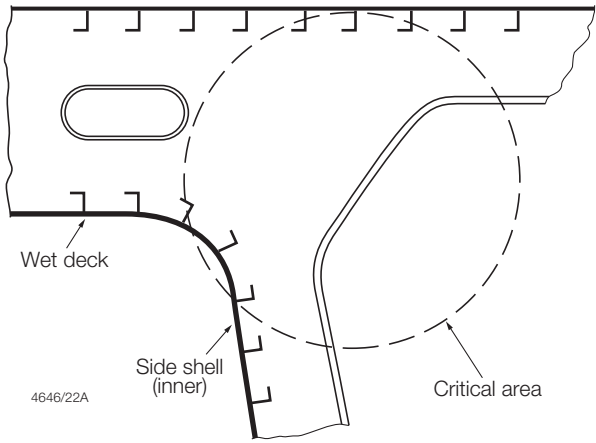
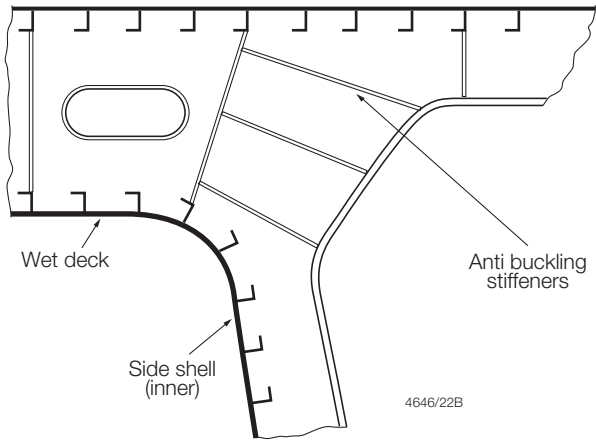
AREA: Cross-deck structure, multi-hulls ITEM: Inner side web frame to deck transverse connection		
CRITICAL AREAS	DETAIL DESIGN IMPROVEMENT	
 <p>Wet deck Side shell (inner) Critical area 4646/22A</p>	 <p>Wet deck Side shell (inner) Anti buckling stiffeners 4646/22B</p>	
<p>NOTES</p> <p>Failure Mechanism Buckling of deep webs.</p> <p>Building Tolerance To be in accordance with Pt 3, Ch 1 of the Rules for Special Service Craft.</p> <p>Welding Requirements To be in accordance with Pt 6, Ch 2 and Pt 7, Ch 2 of the Rules for Special Service Craft, for steel and aluminium alloy craft respectively.</p>		
GROUP 1	GUIDANCE NOTES FOR DESIGN DETAILS STEEL/ALUMINIUM CONSTRUCTION	FIGURE 13

Detail Design Improvement for Steel/Aluminium Construction

Chapter 4

Section 2

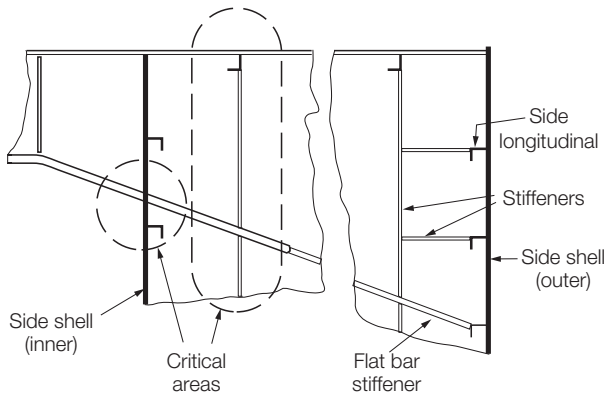
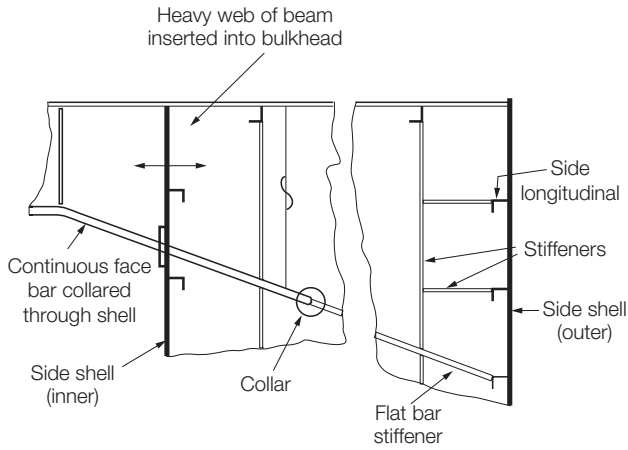
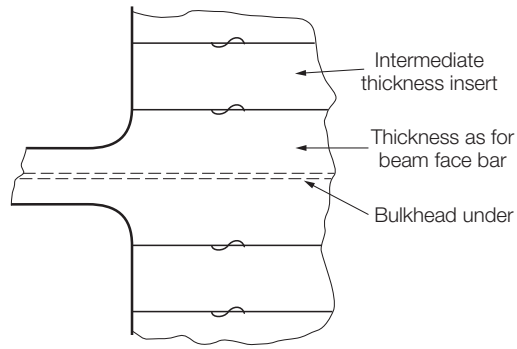
AREA: Cross-deck structure ITEM: Deck transverse to watertight bulkhead connection		
CRITICAL AREAS	DETAIL DESIGN IMPROVEMENT	
 <p style="text-align: right; margin-right: 100px;">4646/23A</p>	  <p style="text-align: center;">Plan view</p> <p style="text-align: right; margin-right: 100px;">4646/23B</p>	
NOTES		
Failure Mechanism	Failure fractures in areas of high stress, cracking due to both stress concentrations and tri-axial stress.	
Building Tolerance	To be in accordance with Pt 3, Ch 1 of the Rules for Special Service Craft.	
Welding Requirements	To be in accordance with Pt 6, Ch 2 and Pt 7, Ch 2 of the Rules for Special Service Craft, for steel and aluminium alloy craft respectively. All welds in way of shell penetration are to be full penetration type.	
GROUP 1	GUIDANCE NOTES FOR DESIGN DETAILS STEEL/ALUMINIUM CONSTRUCTION	FIGURE 14

Detail Design Improvement for Steel/Aluminium Construction

Chapter 4

Section 2

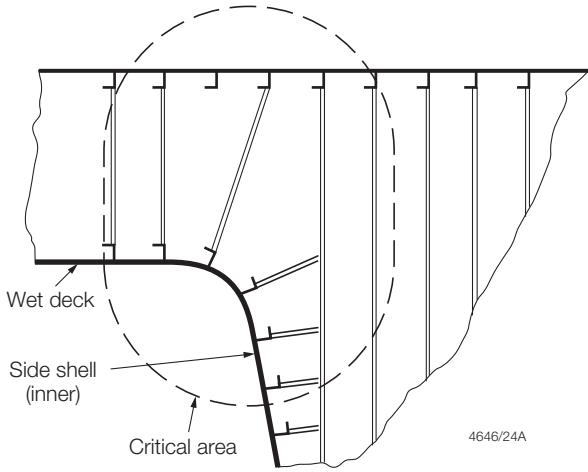
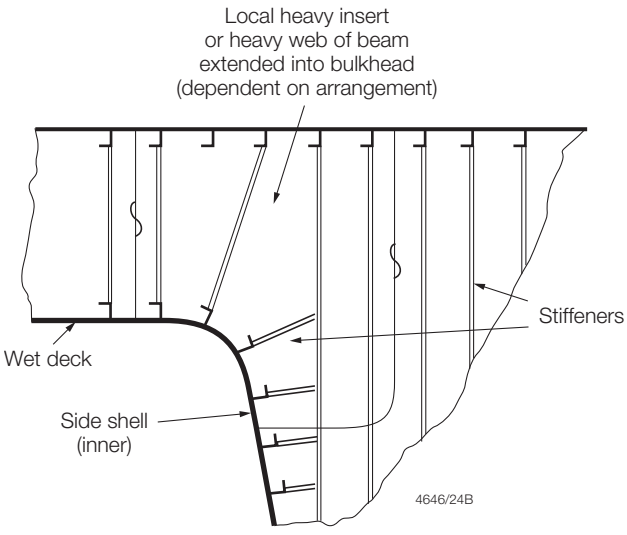
AREA: Multi-hull structure ITEM: Cross-deck beam to bulkhead connection		
CRITICAL AREAS	DETAIL DESIGN IMPROVEMENT	
 <p>4646/24A</p>	 <p>4646/24B</p>	
<p>NOTES</p> <p>Failure Mechanism Buckling of deep webs and bulkhead in way of connection.</p> <p>Building Tolerance To be in accordance with Pt 3, Ch 1 of the Rules for Special Service Craft.</p> <p>Welding Requirements To be in accordance with Pt 6, Ch 2 and Pt 7, Ch 2 of the Rules for Special Service Craft, for steel and aluminium alloy craft respectively. Webs of deep transverses are to be accurately aligned with the bulkhead plating. All welding in way of end connection is to be double continuous type.</p>		
GROUP 1	GUIDANCE NOTES FOR DESIGN DETAILS STEEL/ALUMINIUM CONSTRUCTION	FIGURE 15

Detail Design Improvement for Steel/Aluminium Construction

Chapter 4

Section 2

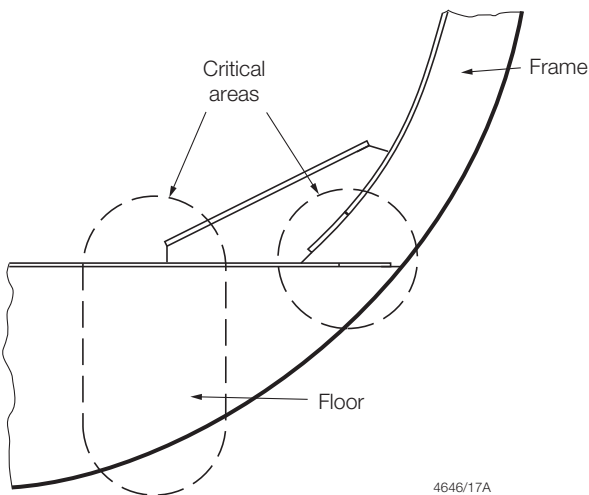
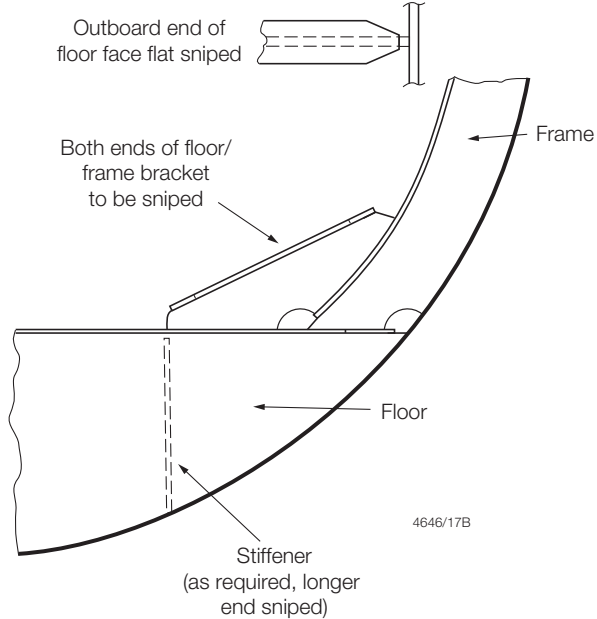
AREA: Hull internal structure ITEM: Floor to frame connection (bracketed)		
CRITICAL AREAS	DETAIL DESIGN IMPROVEMENT	
		
NOTES		
Failure Mechanism	Buckling of floor under bracket toe. Fracturing of frame and floor structure in way of end connections.	
Building Tolerance	To be in accordance with Pt 3, Ch 1 of the Rules for Special Service Craft.	
Welding Requirements	To be in accordance with Pt 6, Ch 2 and Pt 7, Ch 2 of the Rules for Special Service Craft, for steel and aluminium alloy craft respectively. All welding in way of brackets and end connections is to be double continuous type. All welds to be returned around scallops. Webs of frames to be accurately aligned with floor plating.	
GROUP 2	GUIDANCE NOTES FOR DESIGN DETAILS STEEL/ALUMINIUM CONSTRUCTION	FIGURE 16

Detail Design Improvement for Steel/Aluminium Construction

Chapter 4

Section 2

AREA:	Hull internal structure	
ITEM:	Frame to beam connection	

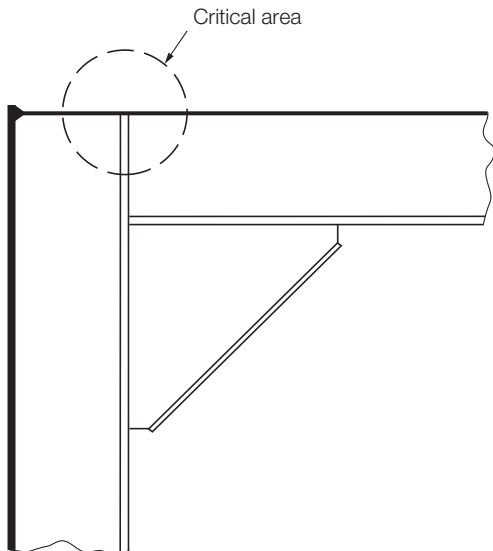
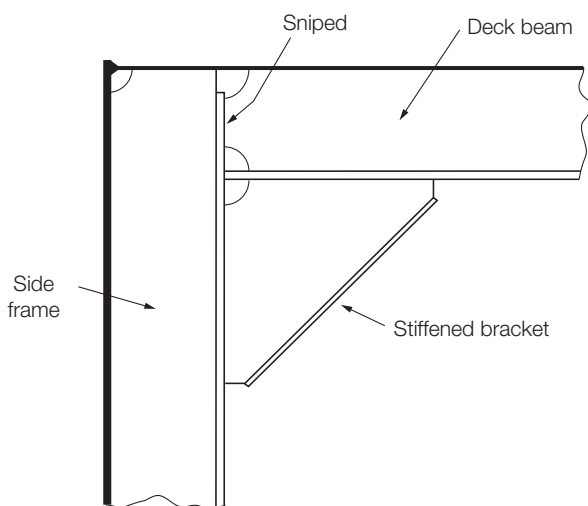
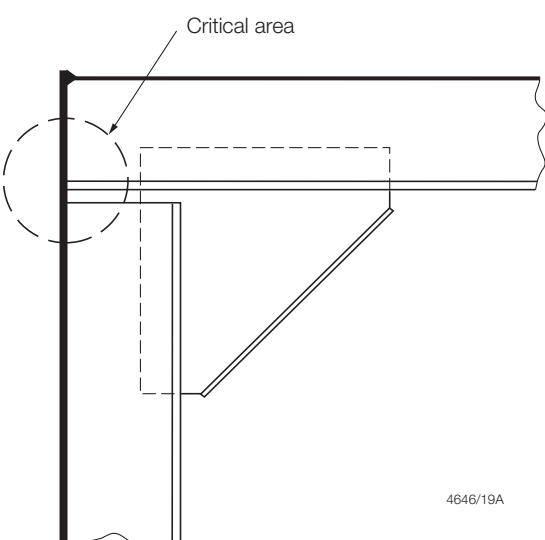
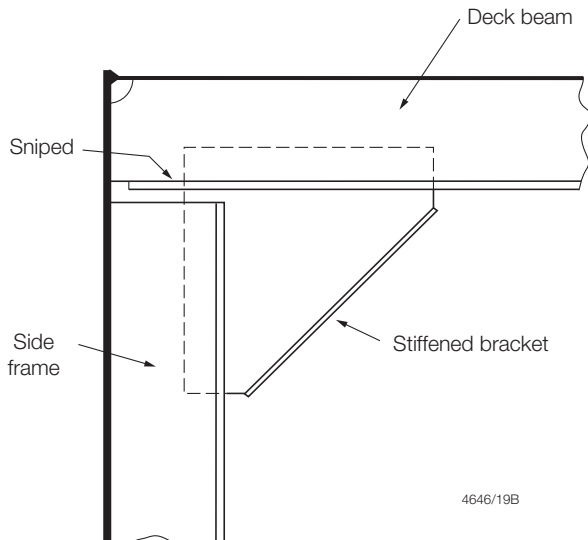
CRITICAL AREAS	DETAIL DESIGN IMPROVEMENT
 <p style="text-align: center;">Critical area</p>	 <p style="text-align: center;">Sniped Deck beam Side frame Stiffened bracket</p>
 <p style="text-align: center;">Critical area</p> <p style="text-align: right;">4646/19A</p>	 <p style="text-align: center;">Sniped Deck beam Side frame Stiffened bracket</p> <p style="text-align: right;">4646/19B</p>

NOTES

Failure Mechanism	Fractures in the shell and deck plating due to stress concentration arising from hard spots.
Building Tolerance	To be in accordance with Pt 3, Ch 1 of the Rules for Special Service Craft.
Welding Requirements	To be in accordance with Pt 6, Ch 2 and Pt 7, Ch 2 of the Rules for Special Service Craft, for steel and aluminium alloy craft respectively. Webs of deck beam to be accurately aligned with webs of frames. All welding in way of end connections and brackets is to be double continuous type. All welds to be returned around scallops.

GROUP 2	GUIDANCE NOTES FOR DESIGN DETAILS STEEL/ALUMINIUM CONSTRUCTION	FIGURE 17
------------	---	--------------

Detail Design Improvement for Steel/Aluminium Construction

Chapter 4

Section 2

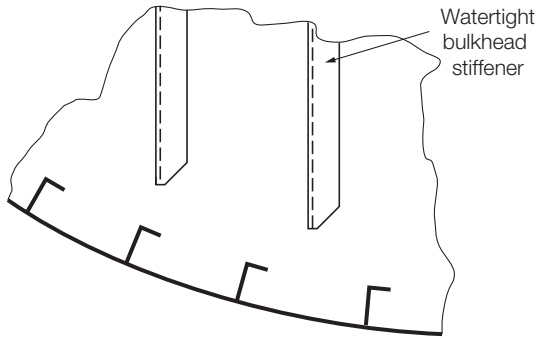
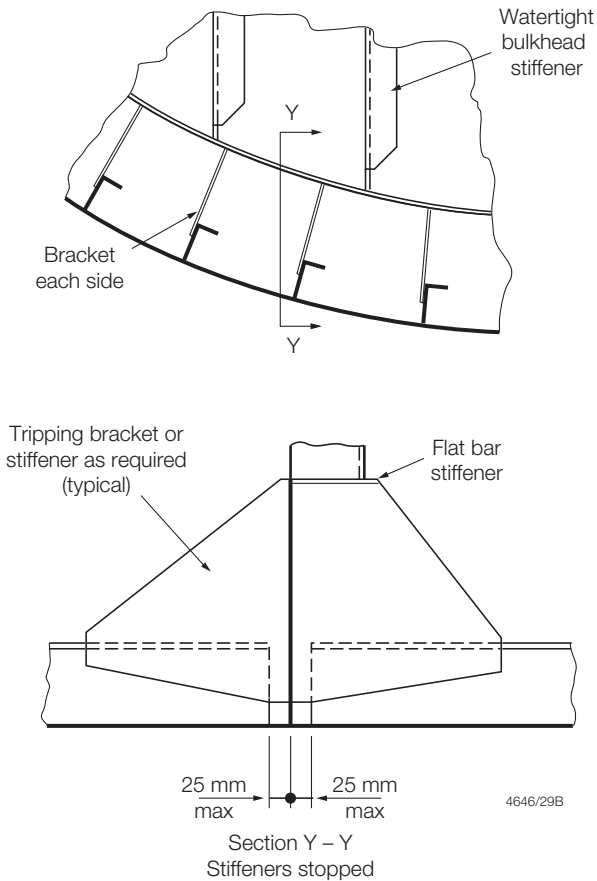
AREA: Watertight/oiltight bulkheads with boundary bar ITEM: Shell longitudinals (lapped brackets)		 Lloyd's Register
CRITICAL AREAS	DETAIL DESIGN IMPROVEMENT	
 <p style="text-align: right;">Watertight bulkhead stiffener</p> <p style="text-align: right;">4646/29A</p>	 <p style="text-align: right;">Watertight bulkhead stiffener</p> <p style="text-align: left;">Bracket each side</p> <p style="text-align: right;">Flat bar stiffener</p> <p style="text-align: left;">Tripping bracket or stiffener as required (typical)</p> <p style="text-align: center;">25 mm max 25 mm max</p> <p style="text-align: center;">Section Y – Y Stiffeners stopped</p> <p style="text-align: right;">4646/29B</p>	
NOTES		
Failure Mechanism Building Tolerance Welding Requirements	Fractures in bulkhead plating arising from stress concentrations in way of longitudinal stiffener end connections. To be in accordance with Pt 3, Ch 1 of the Rules for Special Service Craft. To be in accordance with Pt 6, Ch 2 and Pt 7, Ch 2 of the Rules for Special Service Craft, for steel and aluminium alloy craft respectively. Webs of brackets are to be accurately aligned through the bulkhead platings. All welding in way of brackets and stiffener end connections is to be double continuous type.	
GROUP 2	GUIDANCE NOTES FOR DESIGN DETAILS STEEL/ALUMINIUM CONSTRUCTION	FIGURE 18

Detail Design Improvement for Steel/Aluminium Construction

Chapter 4

Section 2

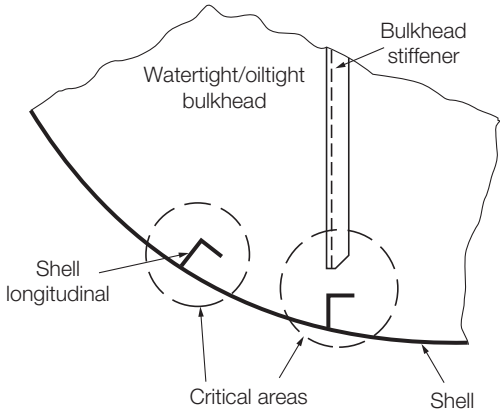
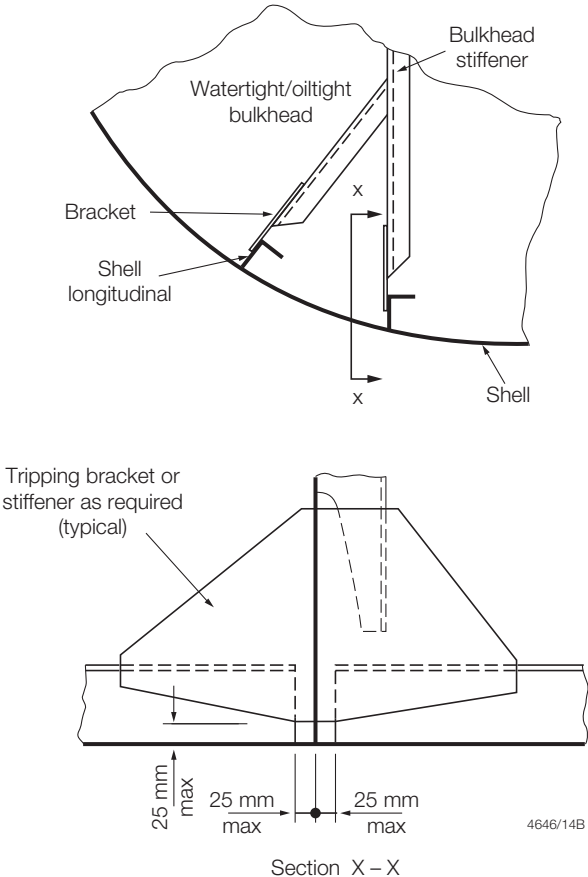
AREA: Watertight/oiltight bulkheads ITEM: Shell longitudinals (lapped brackets)		
CRITICAL AREAS	DETAIL DESIGN IMPROVEMENT	
		
NOTES		
Failure Mechanism Building Tolerance Welding Requirements	Fractures in bulkhead plating arising from stress concentrations in way of longitudinal stiffener end connections. To be in accordance with Pt 3, Ch 1 of the Rules for Special Service Craft. To be in accordance with Pt 6, Ch 2 and Pt 7, Ch 2 of the Rules for Special Service Craft, for steel and aluminium alloy craft respectively. Webs of brackets are to be accurately aligned through the bulkhead platings. All welding in way of brackets and end connections of stiffeners is to be double continuous type.	
GROUP 2	GUIDANCE NOTES FOR DESIGN DETAILS STEEL/ALUMINIUM CONSTRUCTION	FIGURE 19

Detail Design Improvement for Steel/Aluminium Construction

Chapter 4

Section 2

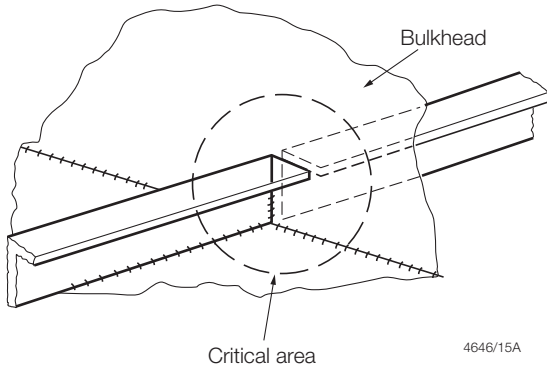
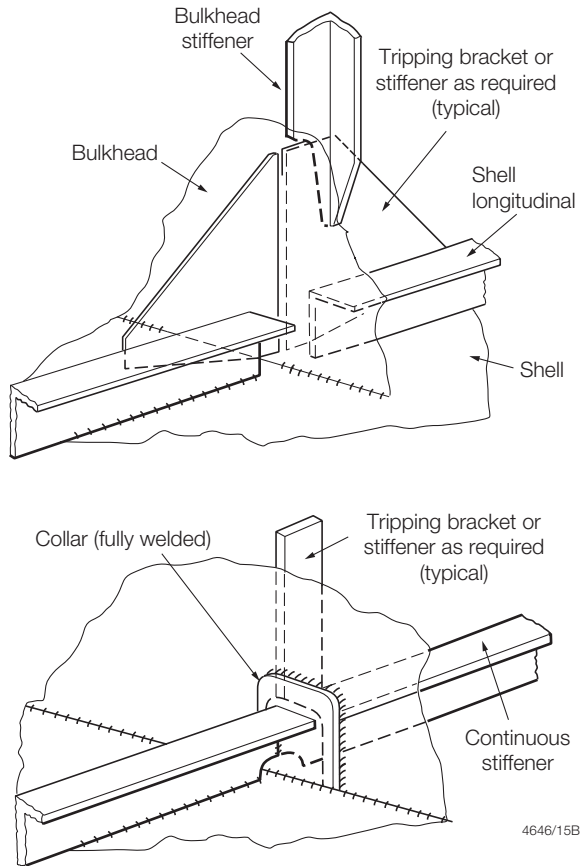
AREA: Watertight/oiltight bulkheads ITEM: Shell longitudinals collared, brackets lapped		
CRITICAL AREAS	DETAIL DESIGN IMPROVEMENT	
 <p>4646/15A</p>	 <p>4646/15B</p>	
NOTES		
Failure Mechanism	Fractures in bulkhead plating arising from stress concentrations in way of longitudinal stiffener end connections.	
Building Tolerance	To be in accordance with Pt 3, Ch 1 of the Rules for Special Service Craft.	
Welding Requirements	To be in accordance with Pt 6, Ch 2 and Pt 7, Ch 2 of the Rules for Special Service Craft, for steel and aluminium alloy craft respectively. All welding in way of collar and stiffener end connections is to be double continuous type. Welds are to be returned around scallops.	
GROUP 2	GUIDANCE NOTES FOR DESIGN DETAILS STEEL/ALUMINIUM CONSTRUCTION	FIGURE 20

Detail Design Improvement for Steel/Aluminium Construction

Chapter 4

Section 2

AREA:	Cross-deck structure, multi-hulls	
ITEM:	Connection between cross-deck beams and side hulls	

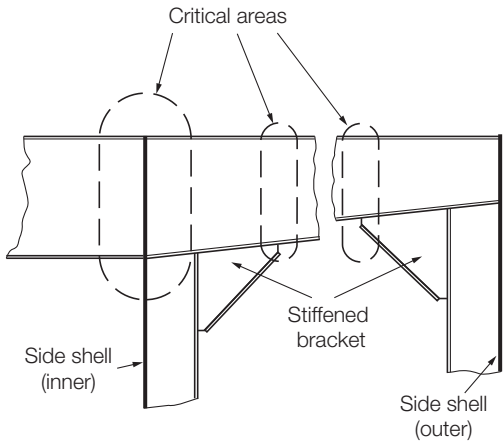
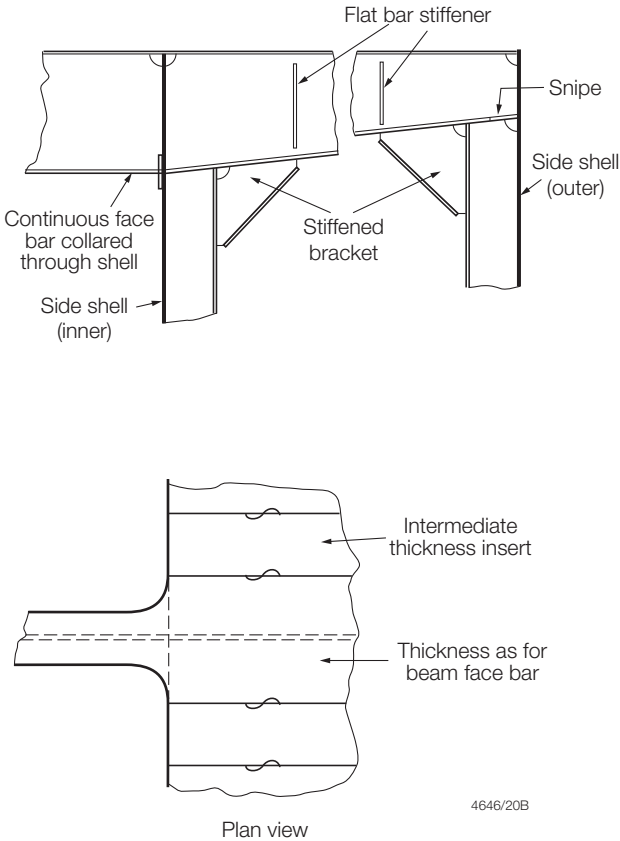
CRITICAL AREAS	DETAIL DESIGN IMPROVEMENT
 <p style="text-align: center;">4646/20A</p>	 <p style="text-align: center;">4646/20B</p>

NOTES	
Failure Mechanism	Buckling of webs of cross-deck beams, and fracturing of deck plating in way of end connection due to hard spot.
Building Tolerance	To be in accordance with Pt 3, Ch 1 of the Rules for Special Service Craft.
Welding Requirements	To be in accordance with Pt 6, Ch 2 and Pt 7, Ch 2 of the Rules for Special Service Craft, for steel and aluminium alloy craft respectively. Webs of frames to be accurately aligned with webs of cross-deck beams. All welds in way of end connection of frames are to be double continuous type. Webs of transverse beams are to be accurately aligned.

GROUP 2	GUIDANCE NOTES FOR DESIGN DETAILS STEEL/ALUMINIUM CONSTRUCTION	FIGURE 21
------------	---	--------------

Detail Design Improvement for Steel/Aluminium Construction

Chapter 4

Section 2

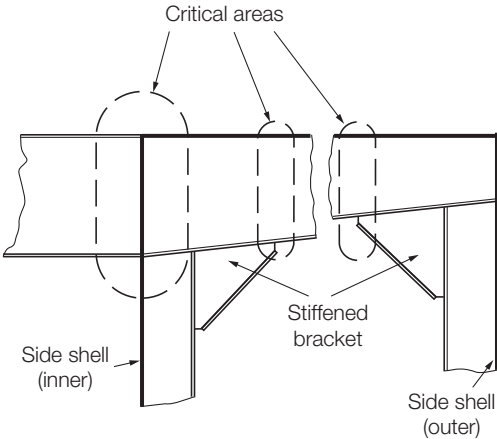
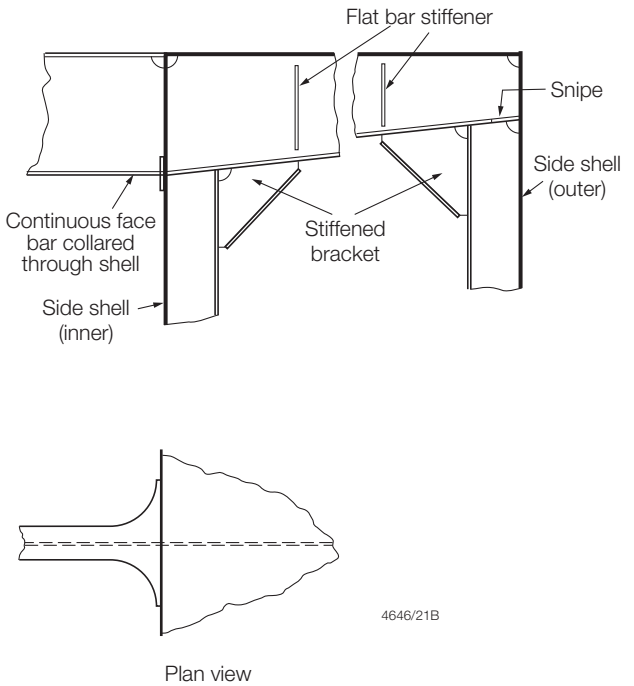
<p>AREA: Cross-deck structure, multi-hulls</p> <p>ITEM: Connection between cross-deck beams and side hulls</p>		 <p>Lloyd's Register</p>
CRITICAL AREAS	DETAIL DESIGN IMPROVEMENT	
 <p style="text-align: center;">4646/21A</p>	 <p style="text-align: center;">4646/21B</p> <p style="text-align: center;">Plan view</p>	
<p>NOTES</p> <p>Failure Mechanism Buckling of webs of cross-deck beams, and fracturing of deck plating in way of end connection due to hard spot.</p> <p>Building Tolerance To be in accordance with Pt 3, Ch 1 of the Rules for Special Service Craft.</p> <p>Welding Requirements To be in accordance with Pt 6, Ch 2 and Pt 7, Ch 2 of the Rules for Special Service Craft, for steel and aluminium alloy craft respectively. Webs of frames to be accurately aligned with webs of cross-deck beams. All welds in way of end connections to be double continuous type. Webs of transverse beams are to be accurately aligned.</p>		
GROUP 3	GUIDANCE NOTES FOR DESIGN DETAILS STEEL/ALUMINIUM CONSTRUCTION	FIGURE 22

Detail Design Improvement for Steel/Aluminium Construction

Chapter 4

Section 2

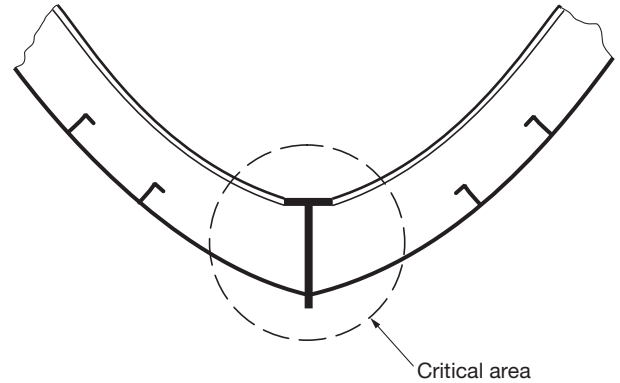
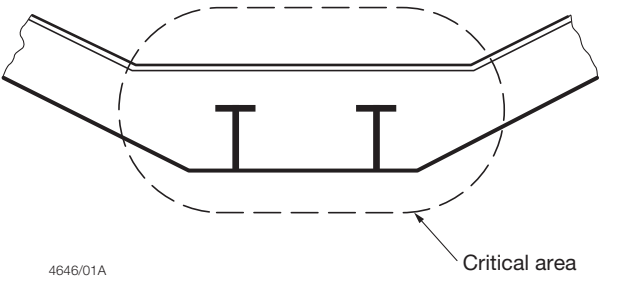
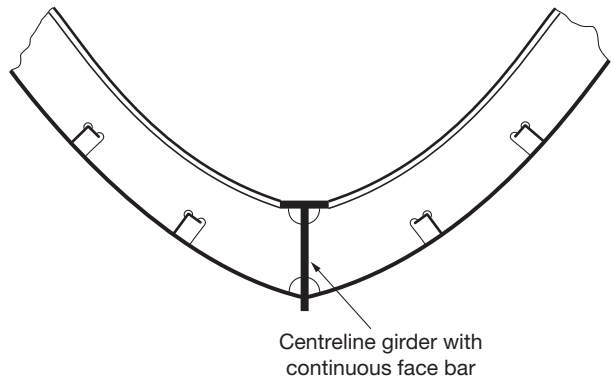
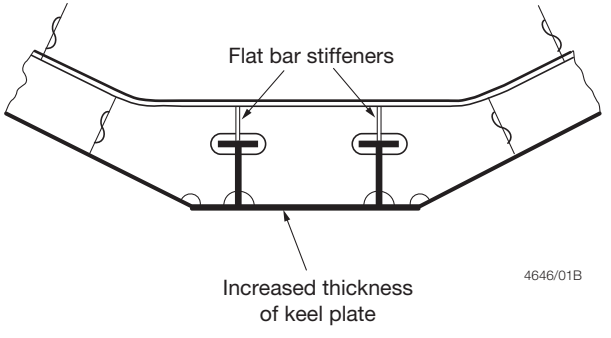
AREA: Hull centreline structure ITEM: Bar and plate keels		
CRITICAL AREAS	DETAIL DESIGN IMPROVEMENT	
 <p style="text-align: center;">Critical area</p>  <p style="text-align: center;">Critical area</p> <p>4646/01A</p>	 <p style="text-align: center;">Centreline girder with continuous face bar</p>  <p style="text-align: center;">Flat bar stiffeners</p> <p style="text-align: center;">Increased thickness of keel plate</p> <p>4646/01B</p>	
NOTES Failure Mechanism Fracturing of centre girder(s), buckling of keel plate and floors. Building Tolerance To be in accordance with Pt 3, Ch 1 of the Rules for Special Service Craft. Welding Requirements To be in accordance with Pt 6, Ch 2 and Pt 7, Ch 2 of the Rules for Special Service Craft, for steel and aluminium alloy craft respectively. Butts in webs are to be staggered from butts in face flats.		
GROUP 3	GUIDANCE NOTES FOR DESIGN DETAILS STEEL/ALUMINIUM CONSTRUCTION	FIGURE 23

Detail Design Improvement for Steel/Aluminium Construction

Chapter 4

Section 2

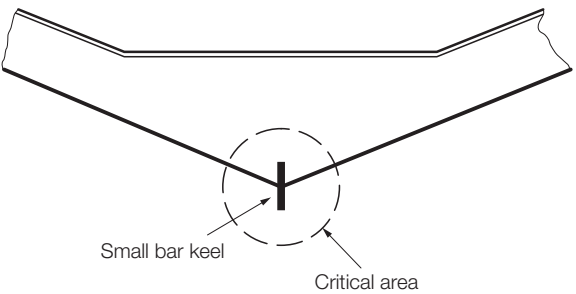
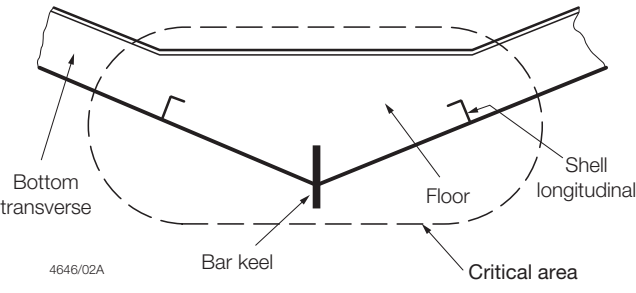
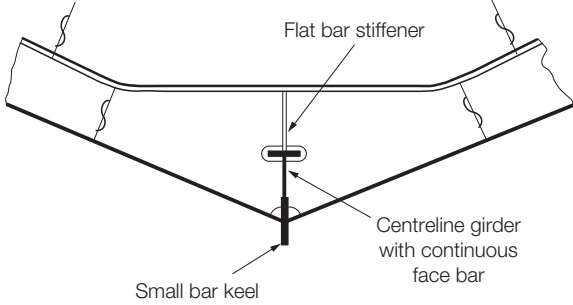
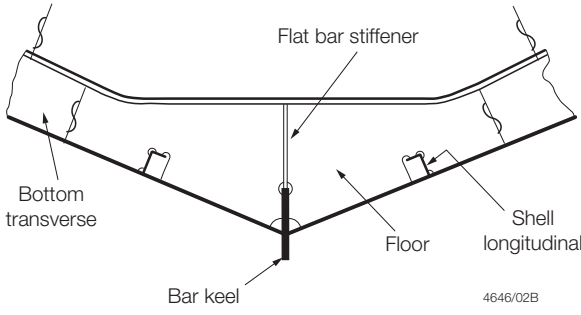
AREA: Hull centreline structure ITEM: Bar keels		
CRITICAL AREAS		DETAIL DESIGN IMPROVEMENT
 		 
NOTES Failure Mechanism Buckling of bar keel, shell plate and floors. Building Tolerance To be in accordance with Pt 3, Ch 1 of the Rules for Special Service Craft. Welding Requirements To be in accordance with Pt 6, Ch 2 and Pt 7, Ch 2 of the Rules for Special Service Craft, for steel and aluminium alloy craft respectively. Butts in webs are to be staggered from butts in face flats.		
GROUP 3	GUIDANCE NOTES FOR DESIGN DETAILS STEEL/ALUMINIUM CONSTRUCTION	FIGURE 24

Detail Design Improvement for Steel/Aluminium Construction

Chapter 4

Section 2

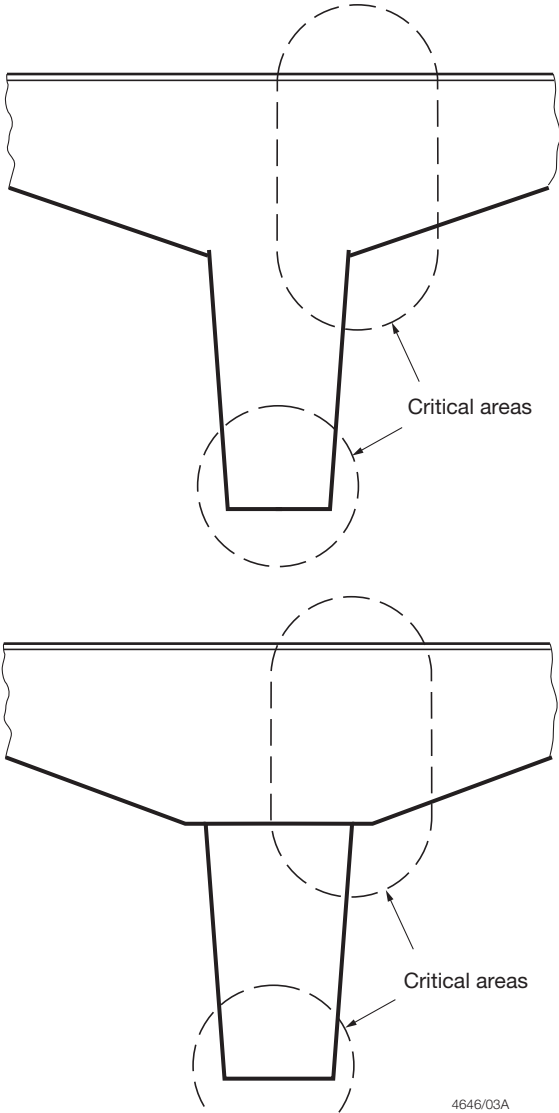
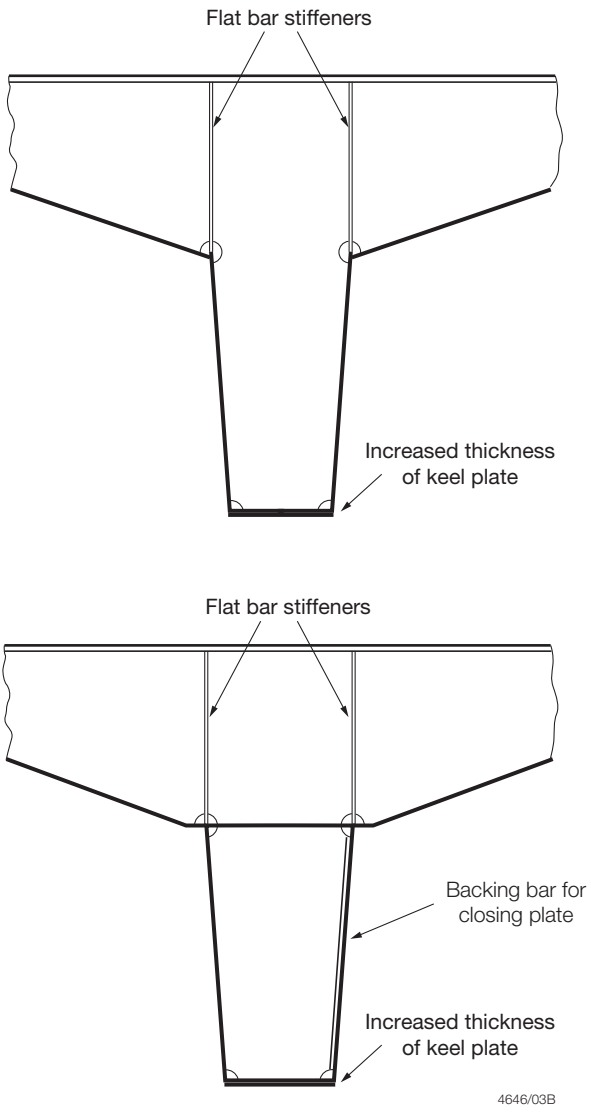
AREA: Hull centreline structure ITEM: Fabricated plate keel/skeg		
CRITICAL AREAS		DETAIL DESIGN IMPROVEMENT
 <p style="text-align: right;">4646/03A</p>		 <p style="text-align: right;">4646/03B</p>
NOTES Failure Mechanism Buckling of keel plate, shell and floor. Fractures from stress concentrations. Building Tolerance To be in accordance with Pt 3, Ch 1 of the Rules for Special Service Craft. Welding Requirements To be in accordance with Pt 6, Ch 2 and Pt 7, Ch 2 of the Rules for Special Service Craft, for steel and aluminium alloy craft respectively.		
GROUP 3	GUIDANCE NOTES FOR DESIGN DETAILS STEEL/ALUMINIUM CONSTRUCTION	FIGURE 25

Detail Design Improvement for Steel/Aluminium Construction

Chapter 4

Section 2

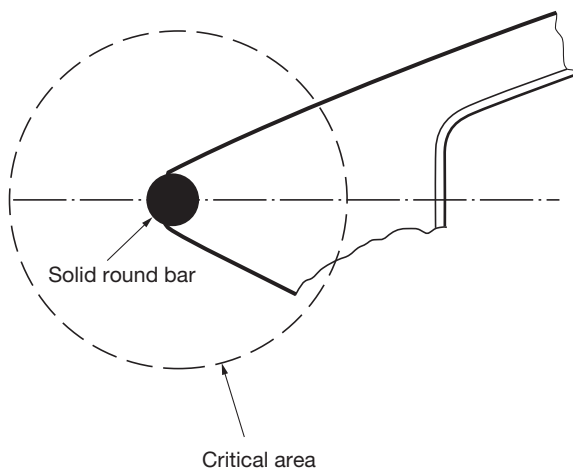
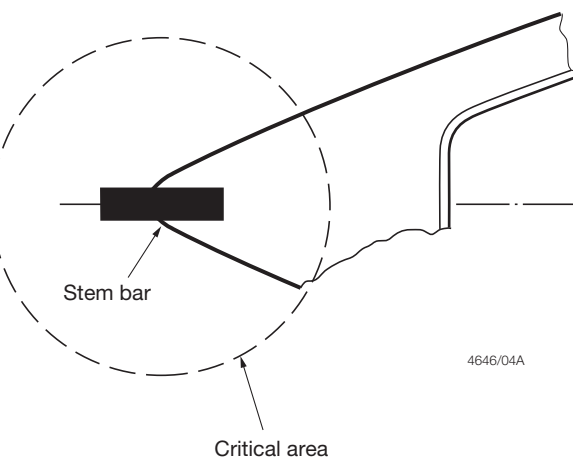
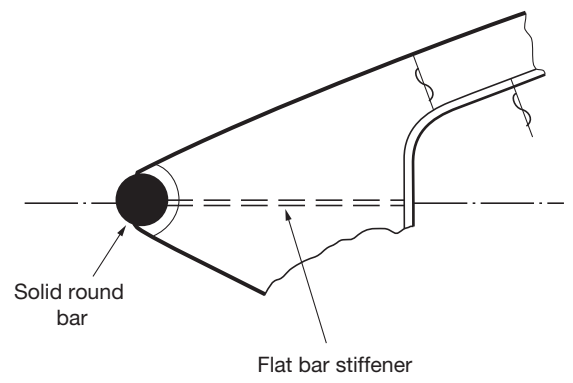
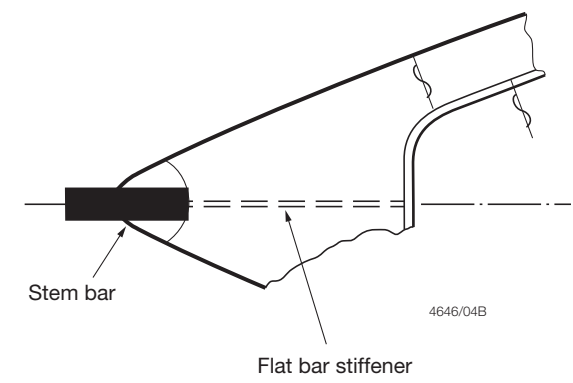
AREA: Hull centreline structure ITEM: Round bar and flat bar stems		
CRITICAL AREAS		DETAIL DESIGN IMPROVEMENT
 <p>Solid round bar</p> <p>Critical area</p>  <p>Stem bar</p> <p>Critical area</p> <p>4646/04A</p>		 <p>Solid round bar</p> <p>Flat bar stiffener</p>  <p>Stem bar</p> <p>Flat bar stiffener</p> <p>4646/04B</p>
NOTES Failure Mechanism Buckling of stem plating due to collision and impact with floating debris. Building Tolerance To be in accordance with Pt 3, Ch 1 of the Rules for Special Service Craft. Welding Requirements To be in accordance with Pt 6, Ch 2 and Pt 7, Ch 2 of the Rules for Special Service Craft, for steel and aluminium alloy craft respectively. All welding between stem bar and shell plating to be full penetration type. Butts in webs are to be staggered from butts in face flats.		
GROUP 3	GUIDANCE NOTES FOR DESIGN DETAILS STEEL/ALUMINIUM CONSTRUCTION	FIGURE 26

Detail Design Improvement for Steel/Aluminium Construction

Chapter 4

Section 2

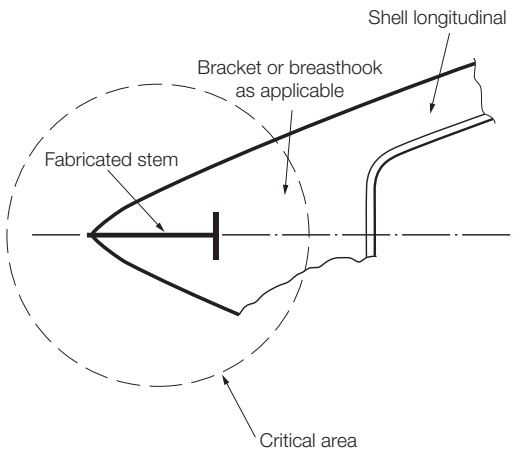
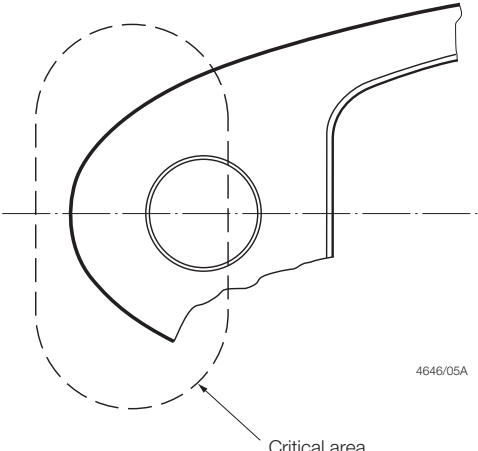
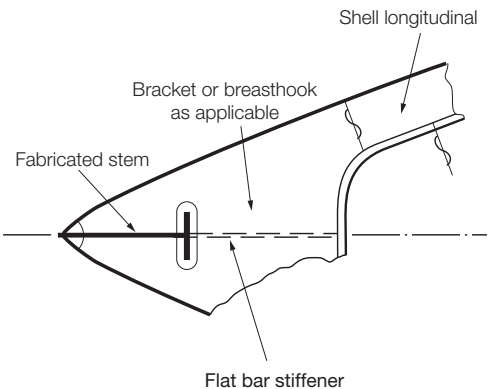
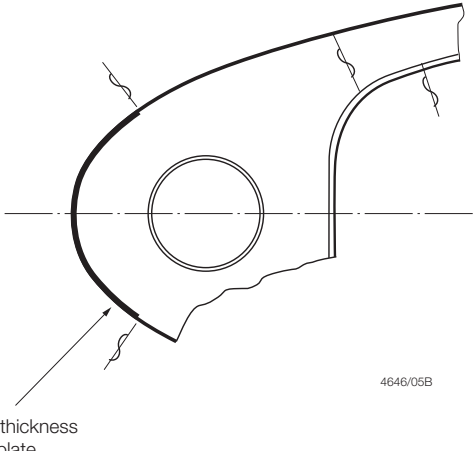
AREA: Hull centreline structure ITEM: Fabricated and plate stems		
CRITICAL AREAS	DETAIL DESIGN IMPROVEMENT	
  <p style="text-align: right;">4646/05A</p>	  <p style="text-align: right;">4646/05B</p>	
NOTES		
Failure Mechanism	Buckling of stem plating due to collision and impact with floating debris.	
Building Tolerance	To be in accordance with Pt 3, Ch 1 of the Rules for Special Service Craft.	
Welding Requirements	To be in accordance with Pt 6, Ch 2 and Pt 7, Ch 2 of the Rules for Special Service Craft, for steel and aluminium alloy craft respectively. All welding between stem and shell plating to be full penetration type. Butts in webs are to be staggered from the butts in face flats.	
GROUP 3	GUIDANCE NOTES FOR DESIGN DETAILS STEEL/ALUMINIUM CONSTRUCTION	FIGURE 27

Detail Design Improvement for Steel/Aluminium Construction

Chapter 4

Section 2

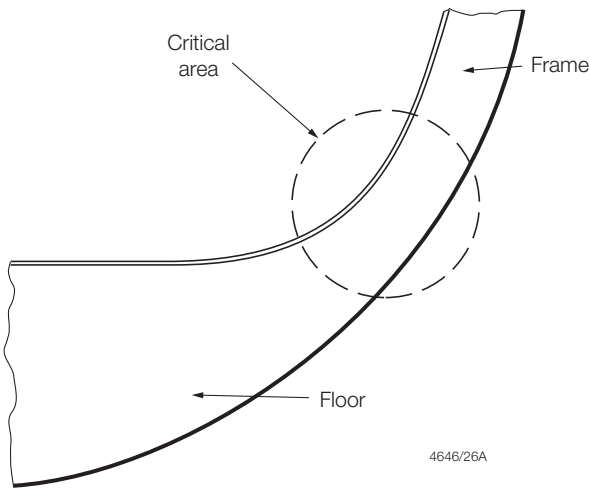
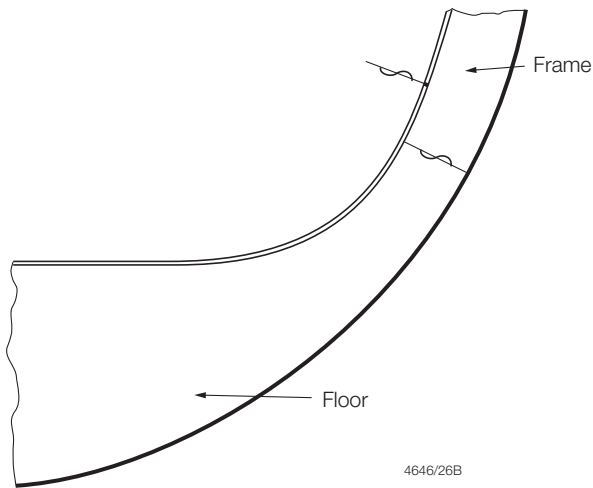
AREA: Internal hull structure ITEM: Floor to frame connection (radiused)		
CRITICAL AREAS	DETAIL DESIGN IMPROVEMENT	
 <p style="text-align: right;">4646/26A</p>		 <p style="text-align: right;">4646/26B</p>
NOTES		
Failure Mechanism	Fatigue fractures in way of welds.	
Building Tolerance	To be in accordance with Pt 3, Ch 1 of the Rules for Special Service Craft.	
Welding Requirements	To be in accordance with Pt 6, Ch 2 and Pt 7, Ch 2 of the Rules for Special Service Craft, for steel and aluminium alloy craft respectively. Webs and face flats are to be accurately aligned with butts between face flats staggered from the butts in the frame webs.	
GROUP 3	GUIDANCE NOTES FOR DESIGN DETAILS STEEL/ALUMINIUM CONSTRUCTION	FIGURE 28

Detail Design Improvement for Steel/Aluminium Construction

Chapter 4

Section 2

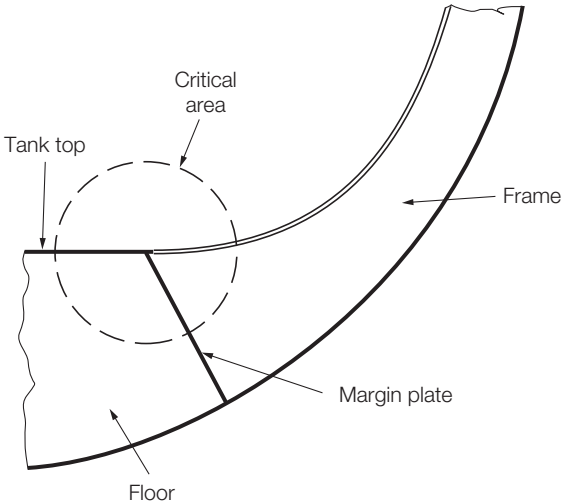
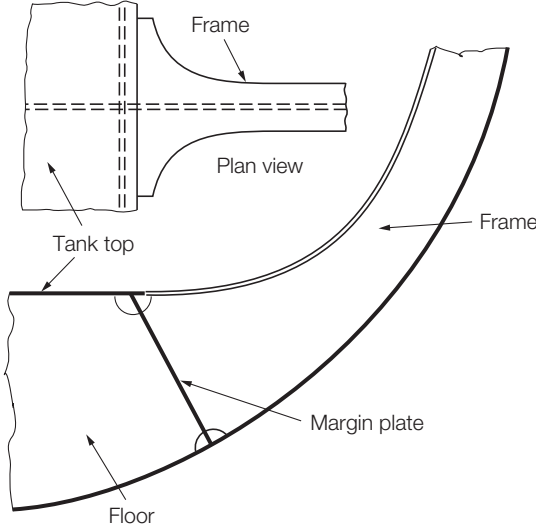
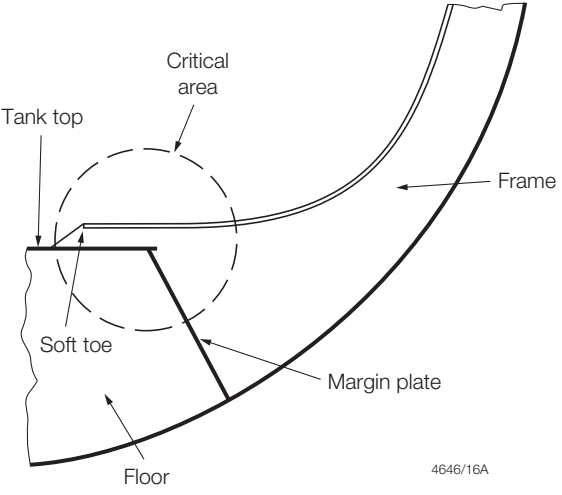
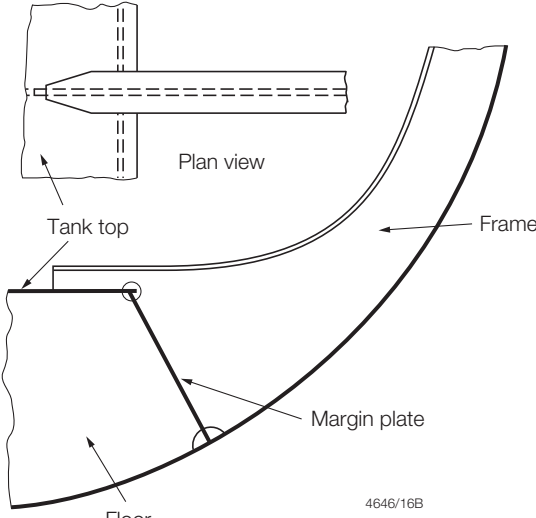
AREA: Hull internal structure ITEM: Web frame to tank boundary connection		
CRITICAL AREAS		DETAIL DESIGN IMPROVEMENT
		
		
NOTES Failure Mechanism Fractures arising from stress concentrations. Building Tolerance To be in accordance with Pt 3, Ch 1 of the Rules for Special Service Craft. Welding Requirements To be in accordance with Pt 6, Ch 2 and Pt 7, Ch 2 of the Rules for Special Service Craft, for steel and aluminium alloy craft respectively. Webs of frames to be accurately aligned with floor plating. All welds in way of end connection of frames are to be double continuous type.		
GROUP 3	GUIDANCE NOTES FOR DESIGN DETAILS STEEL/ALUMINIUM CONSTRUCTION	FIGURE 29

Detail Design Improvement for Composite Construction

Chapter 5

Section 1

Section

1 Identification of critical areas

2 Structural details

■ Section 1 Identification of critical areas

1.1 General

1.1.1 LR has applied direct calculation procedures in the structural appraisal and approval of new buildings and in various investigations on special service craft of composite construction. Through these procedures and the wealth of information collected on the LR fleet database, a number of locations have been identified where good design, workmanship and alignment during construction are particularly important. These are usually locations where high stress variations can be experienced during the lifetime of the craft. These are referred to as **critical locations** and are highlighted in this Chapter.

1.1.2 This Chapter identifies the **critical areas** within various structural elements of the hull structure and transverse bulkheads.

1.1.3 In Section 2 the structural **detail design improvements** that can be applied to increase the fatigue life of the structural components are provided. These detail improvements are intended to give the designer guidance for meeting the design criteria for structural detail components.

1.1.4 The application of 2 and 3-dimensional finite element analyses techniques to the hull structure enables the global and local capabilities of the hull structure to withstand static and dynamic loadings to be assessed. Such analyses will enable those high stress locations and joints within the craft to be readily identified. Such locations will then, by their very nature, be at risk to fatigue damage unless appropriate measures are taken at the design stage and subsequently during construction.

1.1.5 Extensive 'in-service' experience of the performance of existing craft structures, already provide an awareness of those critical locations which merit particular attention either due to stress or alignment difficulties.

1.2 Critical areas

1.2.1 Stress concentrations occur in both the primary and secondary structures of all craft and are identified during the design process by such means as finite element calculations. The designer will modify the detail to alleviate the stress concentration either by redesign or increase in scantlings. However, even after modification that area will still, in general, be exposed throughout the life of the craft to stresses higher than in surrounding areas.

1.2.2 At the design appraisal stage, a plan of the structure should, where appropriate, be prepared by the Builder or designer indicating these regions, and consideration can then be given, by the production team, into the appropriate methods of construction and the tolerances to be applied in order to remain within the assigned design parameters.

1.3 Misalignment during construction

1.3.1 The very nature of composite construction involves the manufacture of the material at the same time as the product and therefore, the alignment of the moulds and formers is one of the major considerations. The bonded interface between structural components in sub-assembly areas, prefabrication stages must also be carefully controlled to ensure accurate alignment and to achieve a satisfactory bond.

1.3.2 The most critical type of joint is the bonded 'tee joint' where it is subjected to high magnitudes of tensile and shear stresses. Particular attention must also be given to the transition between different types of stiffener members i.e., top-hat to plate laminates.

1.3.3 It can readily be seen that the combination of stress concentration and misalignment is to be avoided if the fatigue strength is to be satisfactory during the service life of the craft.

1.4 Fatigue considerations

1.4.1 The bottom shell area of high speed craft is subjected to the highest cyclic loading throughout the life of such craft.

1.4.2 The fatigue cracks in bottom shell laminates in way of internal hard spots, and in way of longitudinal end-connections, has been well documented. Constructional details in way of these areas, designed to increase fatigue life, are now incorporated by many Builders as standard. It is, therefore, important that due consideration be given to these details at the design stage to reduce the risk of fatigue cracking during service.

1.4.3 Detailed recommendations are detailed herein for the critical areas, see Section 2.

■ Section 2

Structural details

2.1 Detail design improvement

2.1.1 For the purposes of these Guidance Notes, structural locations have been divided into five separate groups, with a series of examples of critical structural areas together with alternative associated detail design improvements.

2.1.2 A summary of the data presented is given in Table 5.2.1 whilst the full details are given in Figs. 1 to 30 as contained in this Section.

2.1.3 Generally, where alternative structural detail design improvements are provided, the details shown will provide improved fatigue strength.

2.1.4 Where 'top-hat' sections are shown, the same requirements apply to plate and other stiffening members sections.

Detail Design Improvement for Composite Construction

Chapter 5

Section 2

Table 5.2.1

Group	Application	Area	Item	Fig. No
High speed craft				
1	Sandwich	Chine in way of side shell and bottom shell connection	Chine reinforcement	1
		Stem	Stem reinforcement	2
		Hull bottom structure	Bulkhead to hull connection	3
		Hull bottom structure	Bulkhead to hull connection	4
2	Single skin	Hull structure	Spray rails	5
		Hull structure	Spray rails	6
		Chine in way of side shell and bottom shell connection	Chine reinforcement	7
		Hull internal structure	Bulkhead to hull connection	8
		Hull internal structure	Bulkhead to hull connection	9
Low speed craft				
3	Sandwich	Hull internal structure	Bulkhead to hull connection	10
		Hull internal structure	Bulkhead to hull connection	11
4	Single skin	Hull bottom structure	Bulkhead to hull connection	12
		Hull bottom structure	Bulkhead to hull connection	13
5	General detail	Hull centreline structure	Keel/stem reinforcement and keel stiffening	14
		Hull centreline structure	Keel/stem reinforcement and keel stiffening	15
		Hull structure	Deck to hull connection	16
		Hull structure	Transom boundary	17
		Hull structure	Deck to hull connection	18
		Hull bottom structure	Limber holes	19
		Hull bottom structure	Machinery seating, tapping plates	20
		Hull internal structure	Deep girders and floors	21
		Hull internal structure	'Top-hat' stiffeners penetrating tank boundaries	22
		Hull internal structure	Lower deck/tank top to bottom shell connection	23
		Hull internal structure	Integral tanks access manholes	24
		Skeg (open type)	Skeg stiffening and reinforcement	25
		Skeg (closed type)	Skeg diaphragm plates and sealing laminate	26
		Deck structure	Well deck, lower/sole deck to hull connection	27
		Deck structure	Well deck, lower/sole deck to hull connection	28
		Deck	Bulkhead to deck connection	29
Deck	Deckhouse to deck connection	30		

Detail Design Improvement for Composite Construction

Chapter 5

Section 2



AREA: Chine in way of side shell and bottom shell connection

ITEM: Chine reinforcement

CRITICAL AREAS

DETAIL DESIGN IMPROVEMENT

Sandwich construction

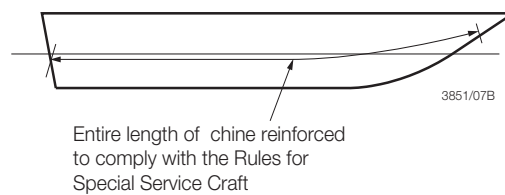
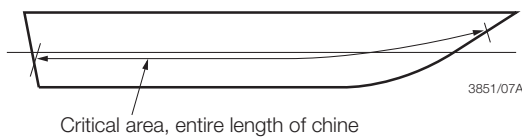
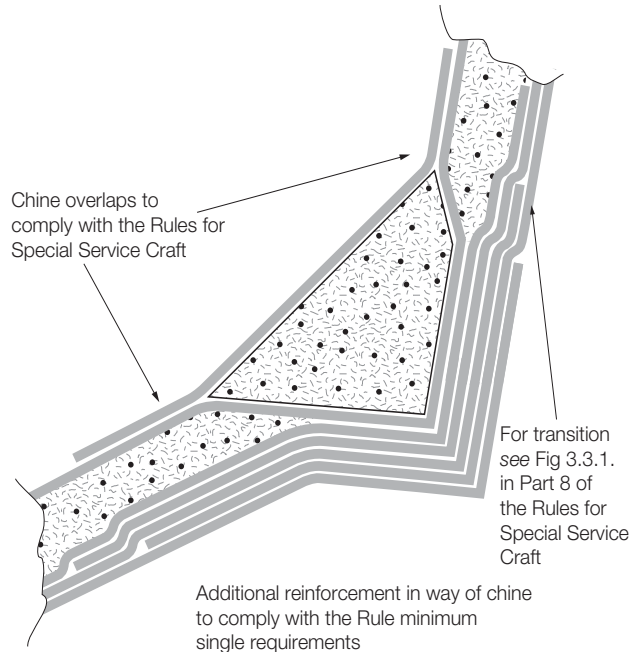
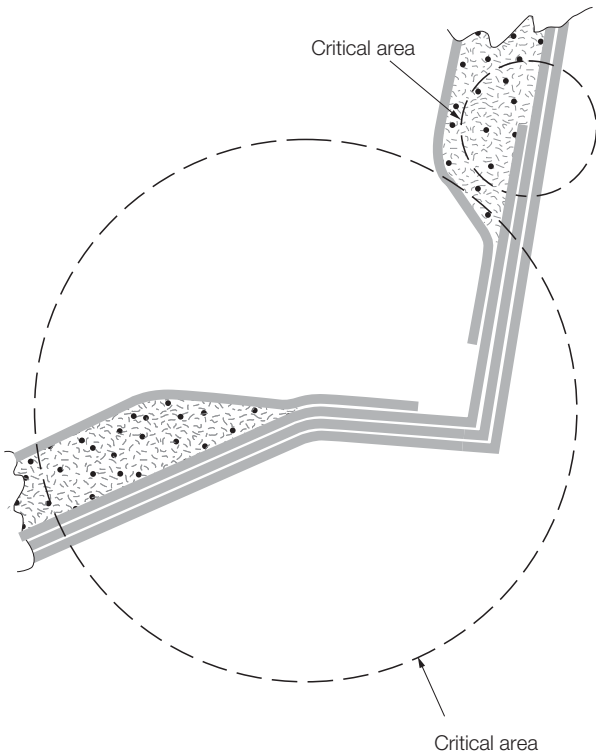

NOTES

Failure Mechanism	Excess loads due to grounding, docking, slinging, hydrodynamic and other types of impact.
Building Tolerance	All FRP materials to comply with the Rules for Special Service Craft.
Laminating Requirements	To be in accordance with Part 8 of the Rules for Special Service Craft.

GROUP
1

GUIDANCE NOTES FOR DESIGN DETAILS
COMPOSITE CONSTRUCTION

FIGURE
1

Detail Design Improvement for Composite Construction

Chapter 5

Section 2

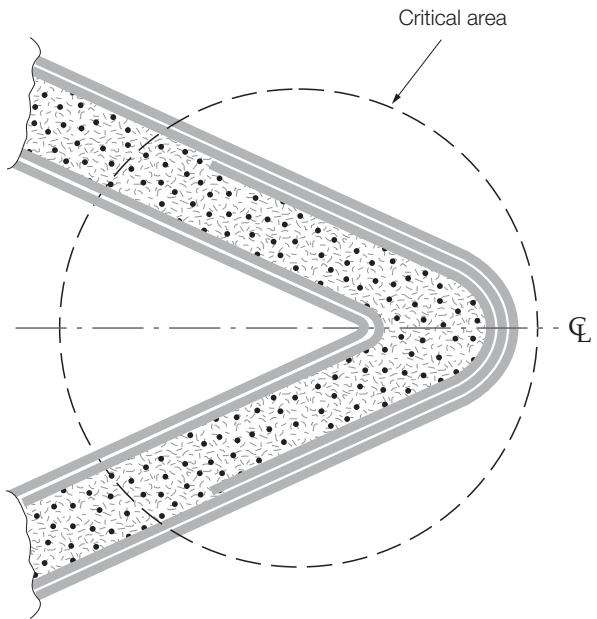
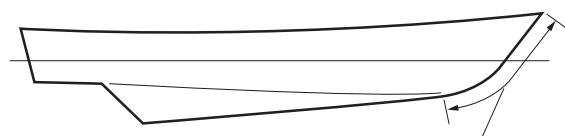
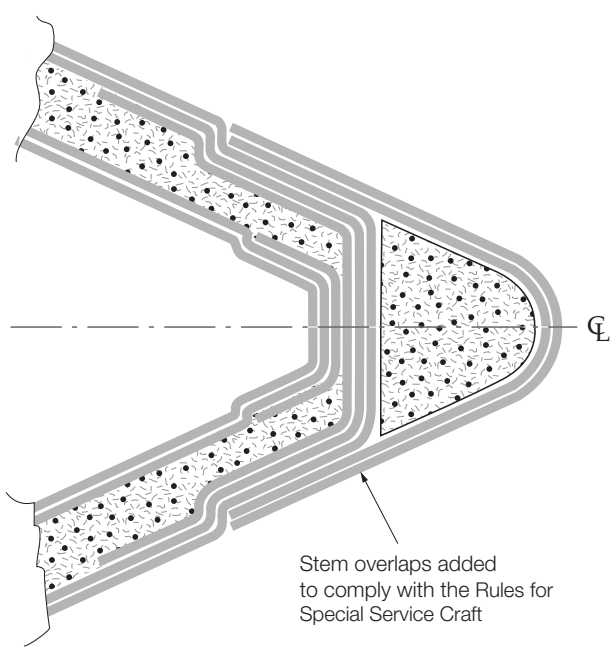
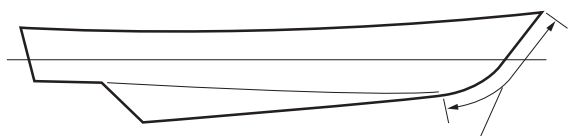
AREA: Stem ITEM: Stem reinforcement		
CRITICAL AREAS		DETAIL DESIGN IMPROVEMENT
<p>Sandwich construction</p>   <p>3851/05A</p> <p>Critical area, entire length of stem</p>		 <p>Stem overlaps added to comply with the Rules for Special Service Craft</p>  <p>3851/05A</p> <p>Entire length of stem reinforced to comply with the Rules for Special Service Craft</p>
<p>NOTES</p> <p>Failure Mechanism Excess loads due to collision and impact with floating debris.</p> <p>Building Tolerance All FRP materials to comply with the Rules for Special Service Craft.</p> <p>Laminating Requirements To be in accordance with Part 8 of the Rules for Special Service Craft.</p>		
GROUP 1	GUIDANCE NOTES FOR DESIGN DETAILS COMPOSITE CONSTRUCTION	FIGURE 2

Detail Design Improvement for Composite Construction

Chapter 5

Section 2



AREA: Hull bottom structure
 ITEM: Bulkhead to hull connection

CRITICAL AREAS

Sandwich construction, high speed

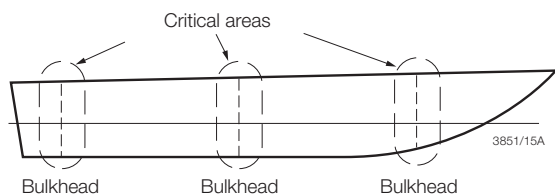
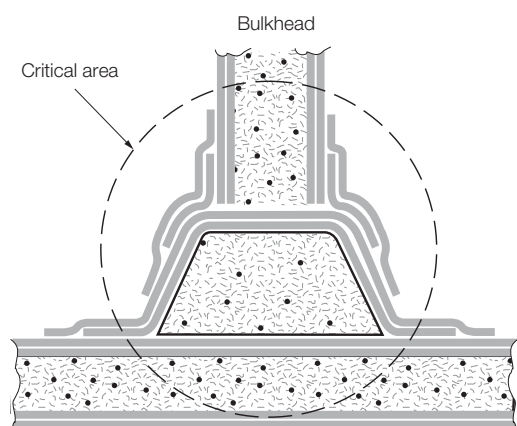

DETAIL DESIGN IMPROVEMENT

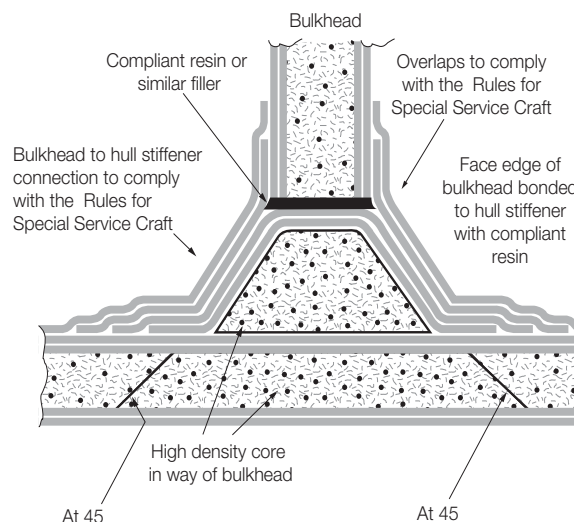

All bulkhead hull connections to comply with the Rules for Special Service Craft

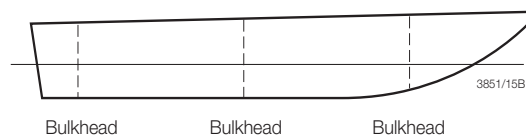

NOTES

Failure Mechanism	Crushing of the sandwich core under the bulkhead, and delamination of the sandwich bulkhead due to excess loads arising from berthing, slinging, impact and racking.
Building Tolerance	All FRP material to comply with the Rules for Special Service Craft.
Laminating Requirements	To be in accordance with Part 8 of the Rules for Special Service Craft.

GROUP
1

GUIDANCE NOTES FOR DESIGN DETAILS
COMPOSITE CONSTRUCTION

FIGURE
3

Detail Design Improvement for Composite Construction

Chapter 5

Section 2

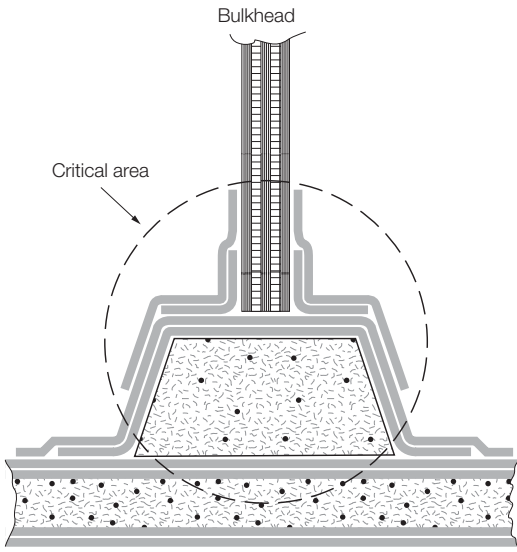
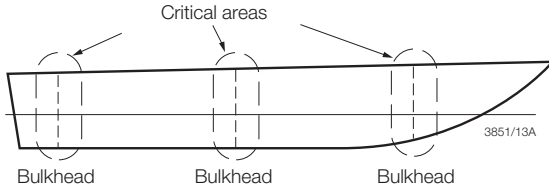
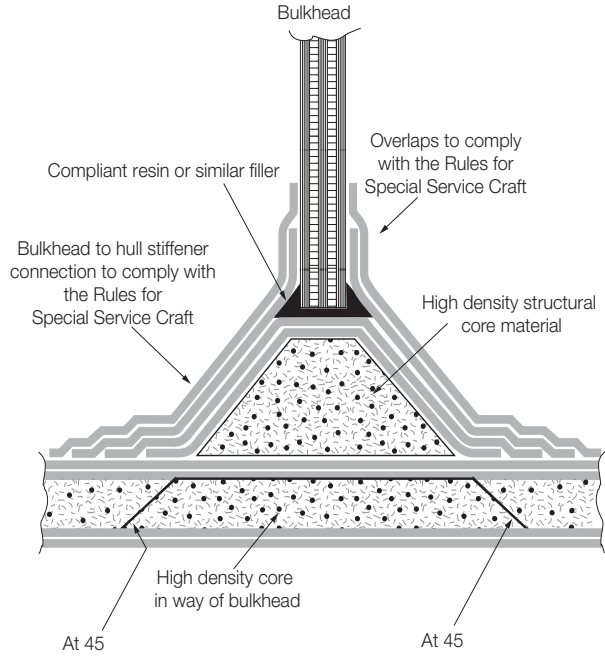
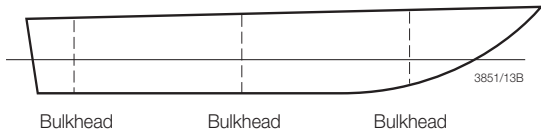
AREA: Hull bottom structure ITEM: Bulkhead to hull connection		
CRITICAL AREAS	DETAIL DESIGN IMPROVEMENT	
<p>Sandwich construction, high speed</p>   <p style="text-align: right; font-size: small;">3851/13A</p>	 <p style="text-align: center;">All bulkhead hull connections to comply with the Rules for Special Service Craft</p>  <p style="text-align: right; font-size: small;">3851/13B</p>	
NOTES Failure Mechanism Crushing of the sandwich core under the bulkhead due to excess loads arising from berthing, slinging, impact and racking. Building Tolerance All FRP material to comply with the Rules for Special Service Craft. Laminating Requirements To be in accordance with Part 8 of the Rules for Special Service Craft.		
GROUP 1	GUIDANCE NOTES FOR DESIGN DETAILS COMPOSITE CONSTRUCTION	FIGURE 4

Detail Design Improvement for Composite Construction

Chapter 5

Section 2

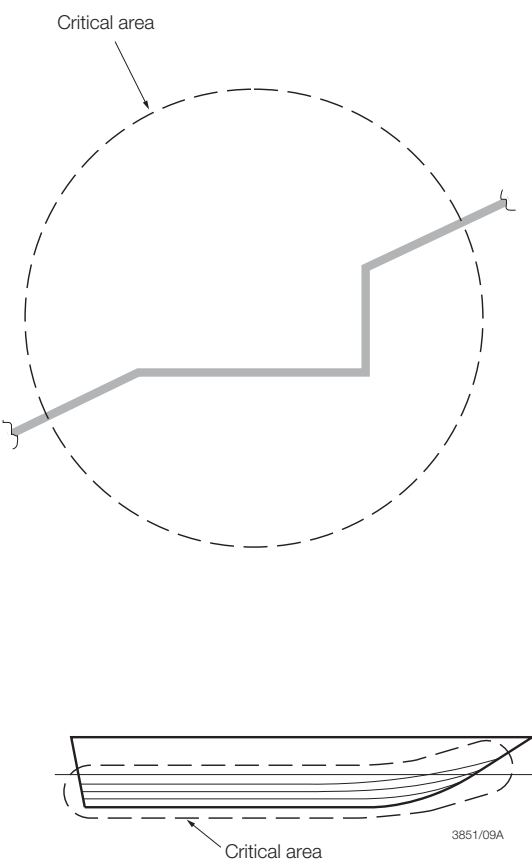
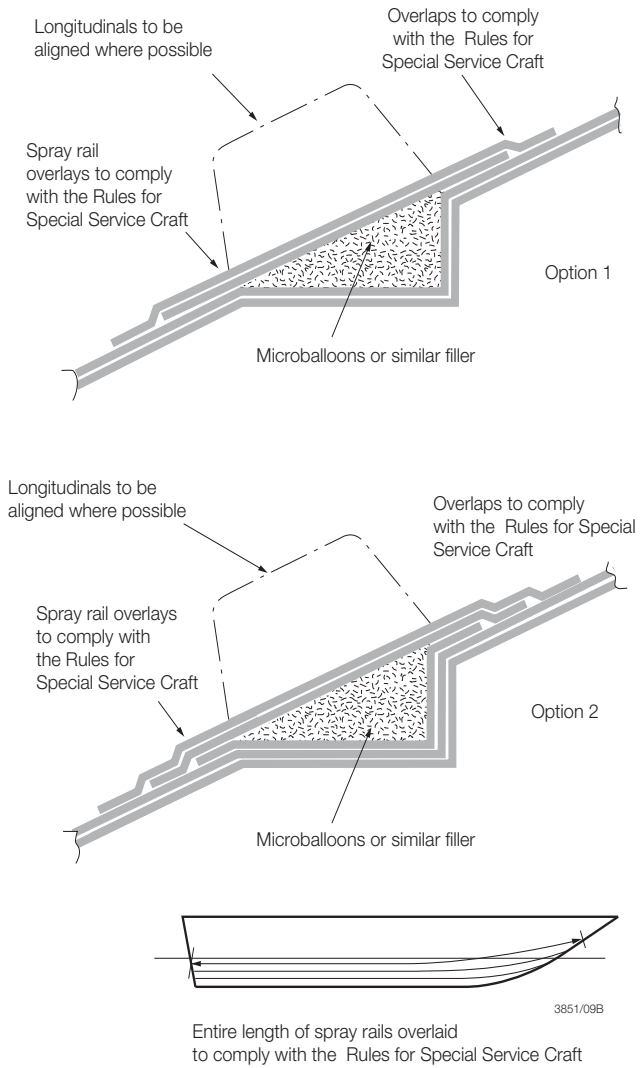
AREA: Hull structure ITEM: Spray rails		
CRITICAL AREAS		DETAIL DESIGN IMPROVEMENT
<p>Single skin construction</p> 		
<p>NOTES</p> <p>Failure Mechanism Excess loads due to grounding and impact.</p> <p>Building Tolerance All FRP material to comply with the Rules for Special Service Craft.</p> <p>Laminating Requirements To be in accordance with Part 8 of the Rules for Special Service Craft.</p>		
GROUP 2	GUIDANCE NOTES FOR DESIGN DETAILS COMPOSITE CONSTRUCTION	FIGURE 5

Detail Design Improvement for Composite Construction

Chapter 5

Section 2

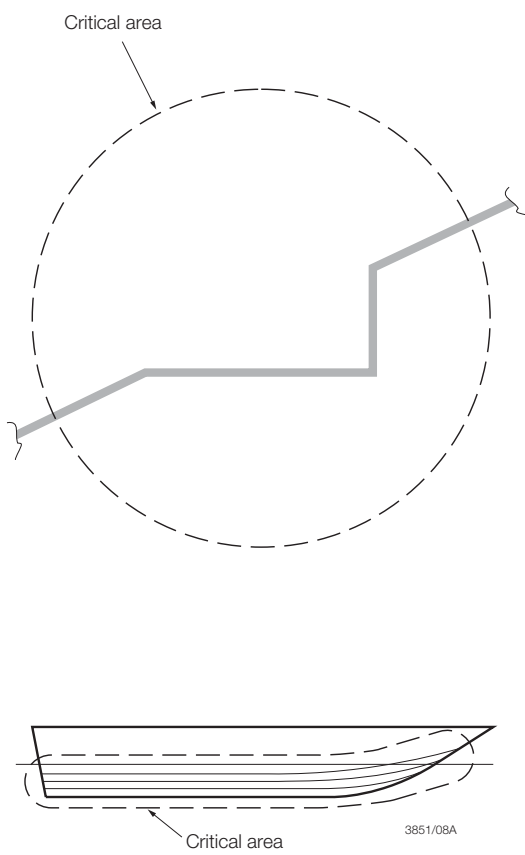
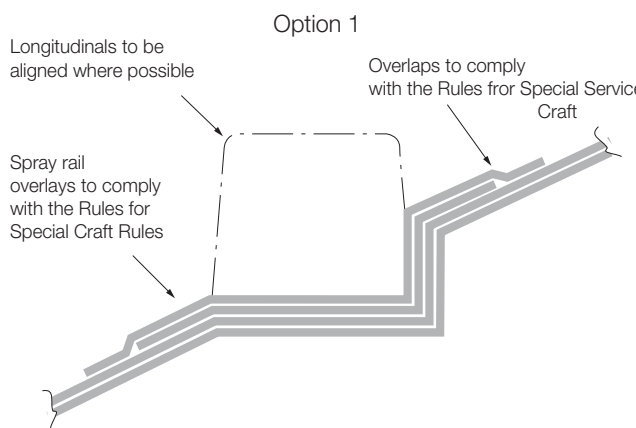
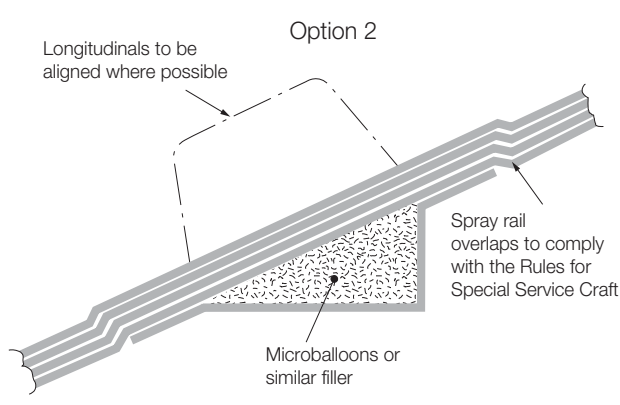
AREA: Hull structure ITEM: Spray rails		
CRITICAL AREAS		DETAIL DESIGN IMPROVEMENT
<p>Single skin construction</p>  <p>Critical area</p> <p>Critical area</p> <p>3851/08A</p>		<p>Option 1</p> <p>Longitudinals to be aligned where possible</p> <p>Overlaps to comply with the Rules for Special Service Craft</p> <p>Spray rail overlays to comply with the Rules for Special Craft Rules</p>  <p>Option 2</p> <p>Longitudinals to be aligned where possible</p> <p>Microballoons or similar filler</p> <p>Spray rail overlaps to comply with the Rules for Special Service Craft</p>  <p>3851/08B</p> <p>Entire length of spray rails overlaid to comply with the Rules for Special Service Craft</p>
<p>NOTES</p> <p>Failure Mechanism Excess loads due to grounding and impact.</p> <p>Building Tolerance All FRP material to comply with the Rules for Special Service Craft.</p> <p>Laminating Requirements To be in accordance with the Part 8 of the Rules for Special Service Craft.</p>		
GROUP 2	GUIDANCE NOTES FOR DESIGN DETAILS COMPOSITE CONSTRUCTION	FIGURE 6

Detail Design Improvement for Composite Construction

Chapter 5

Section 2

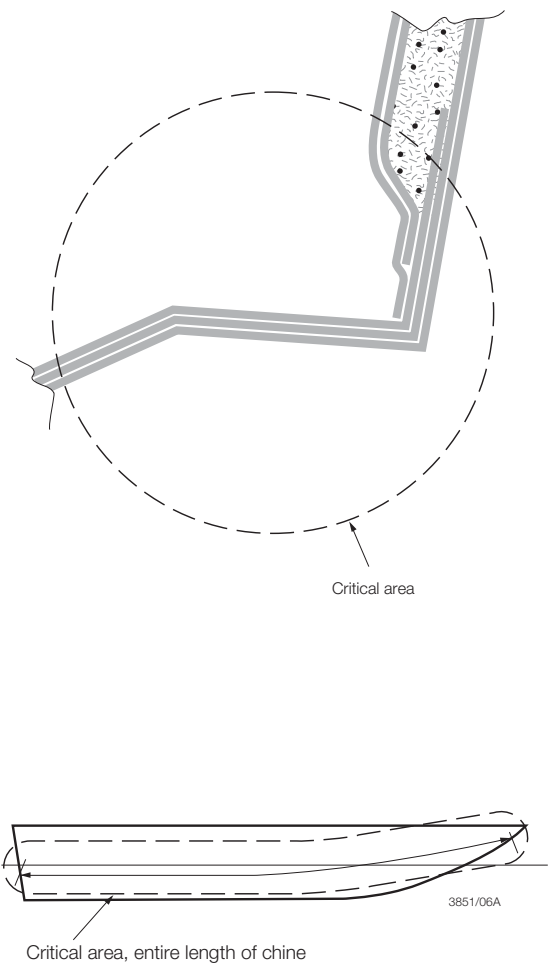
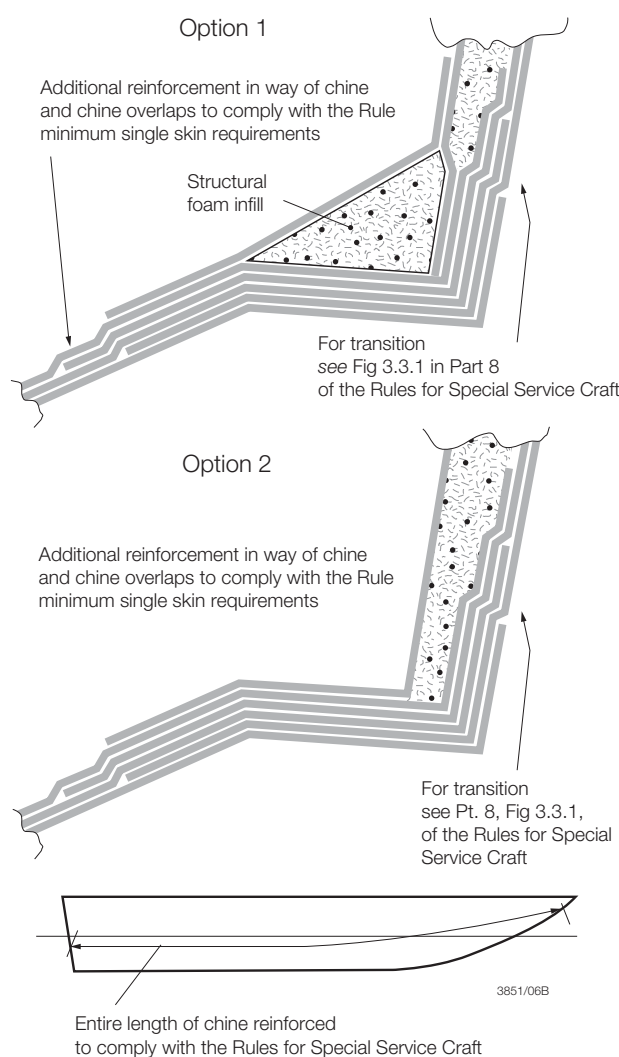
<p>AREA: Chine in way of side shell and bottom shell connection</p> <p>ITEM: Chine reinforcement</p>		
CRITICAL AREAS	DETAIL DESIGN IMPROVEMENT	
<p>Sandwich side and single skin bottom</p> 	<p>Option 1</p> <p>Additional reinforcement in way of chine and chine overlaps to comply with the Rule minimum single skin requirements</p> <p>Structural foam infill</p> <p>For transition see Fig 3.3.1 in Part 8 of the Rules for Special Service Craft</p> <p>Option 2</p> <p>Additional reinforcement in way of chine and chine overlaps to comply with the Rule minimum single skin requirements</p> <p>For transition see Pt. 8, Fig 3.3.1, of the Rules for Special Service Craft</p> <p>Entire length of chine reinforced to comply with the Rules for Special Service Craft</p> 	
<p>NOTES</p> <p>Failure Mechanism Excess loads due to grounding, docking, slinging and hydrodynamic impact.</p> <p>Building Tolerance All FRP material to comply with the Rules for Special Service Craft</p> <p>Laminating Requirements To be in accordance with the Part 8 of the Rules for Special Service Craft.</p>		
GROUP 2	GUIDANCE NOTES FOR DESIGN DETAILS COMPOSITE CONSTRUCTION	FIGURE 7

Detail Design Improvement for Composite Construction

Chapter 5

Section 2

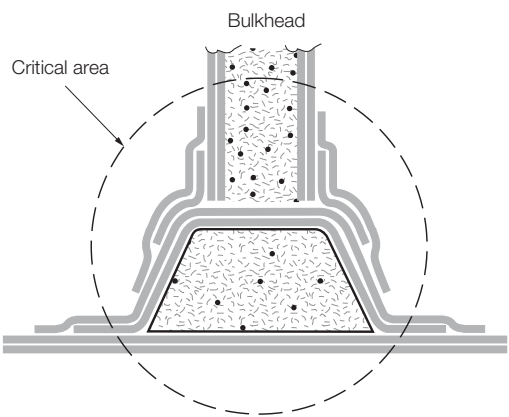
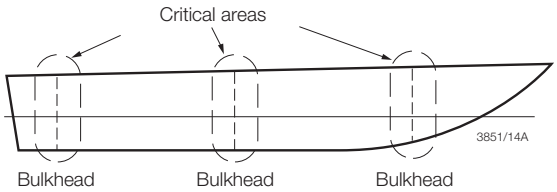
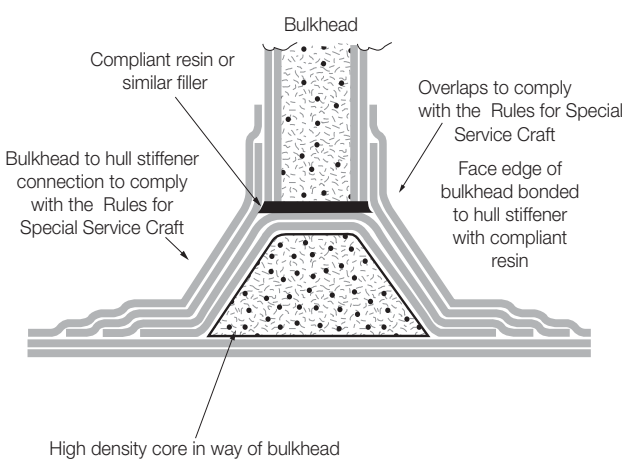
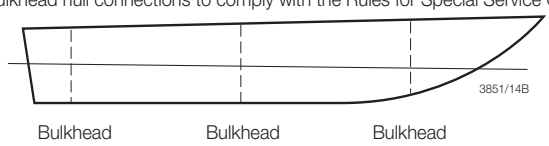
AREA: Hull internal structure ITEM: Bulkhead to hull connection		
CRITICAL AREAS		DETAIL DESIGN IMPROVEMENT
<p>Single skin construction, high speed</p>   <p style="text-align: right;">3851/14A</p>		 <p>All bulkhead hull connections to comply with the Rules for Special Service Craft</p>  <p style="text-align: right;">3851/14B</p>
<p>NOTES</p> <p>Failure Mechanism Excess loads due to berthing, slinging, impact and racking.</p> <p>Building Tolerance All FRP material to comply with the Rules for Special Service Craft.</p> <p>Laminating Requirements To be in accordance with the Part 8 of the Rules for Special Service Craft.</p>		
GROUP 2	GUIDANCE NOTES FOR DESIGN DETAILS COMPOSITE CONSTRUCTION	FIGURE 8

Detail Design Improvement for Composite Construction

Chapter 5

Section 2

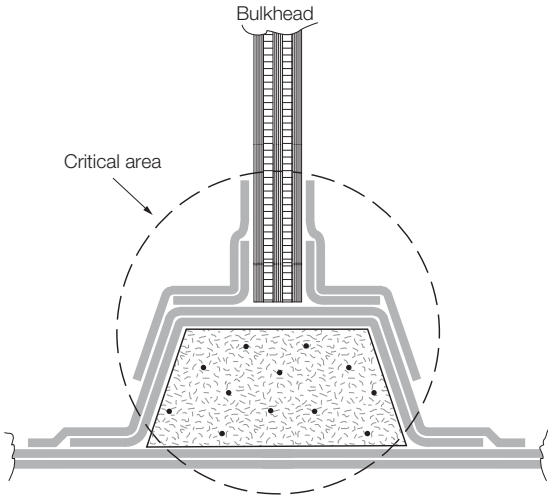
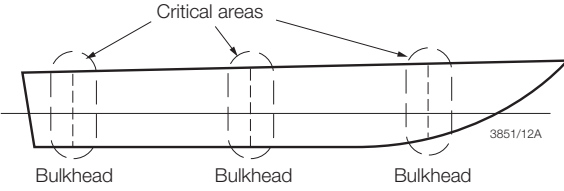
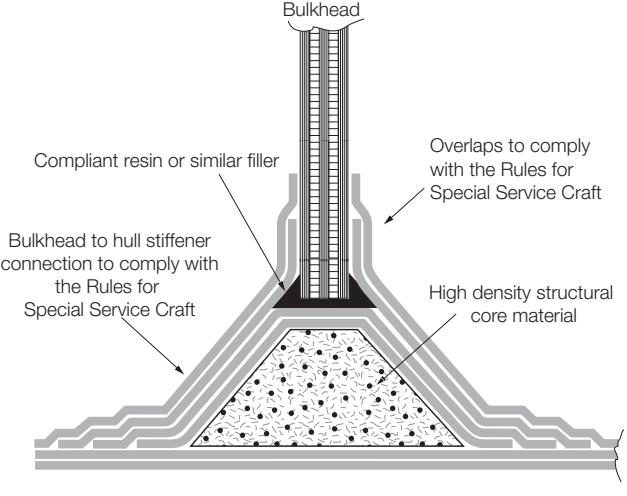
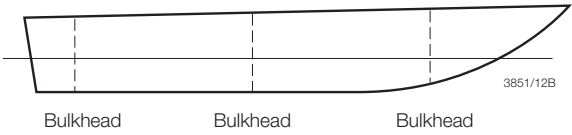
AREA: Hull internal structure ITEM: Bulkhead to hull connection		
CRITICAL AREAS		DETAIL DESIGN IMPROVEMENT
<p>Single skin construction, high speed</p>   <p style="text-align: right;">3851/12A</p>		 <p>All bulkhead to hull connections to comply with the Rules for Special Service Craft</p>  <p style="text-align: right;">3851/12B</p>
<p>NOTES</p> <p>Failure Mechanism Excess loads due to berthing, slinging, impact and racking.</p> <p>Building Tolerance All FRP material to comply with the Rules for Special Service Craft.</p> <p>Laminating Requirements To be in accordance with Part 8 of the Rules for Special Service Craft.</p>		
GROUP 2	GUIDANCE NOTES FOR DESIGN DETAILS COMPOSITE CONSTRUCTION	FIGURE 9

Detail Design Improvement for Composite Construction

Chapter 5

Section 2

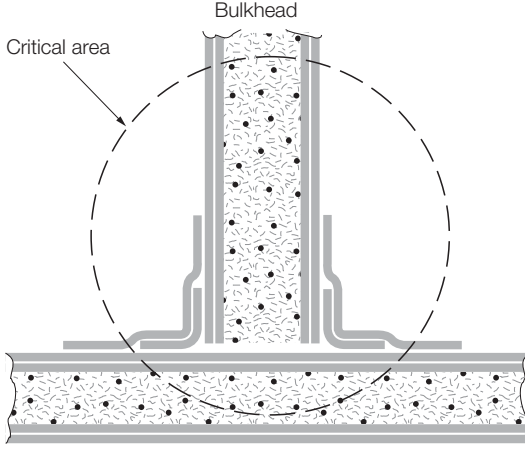
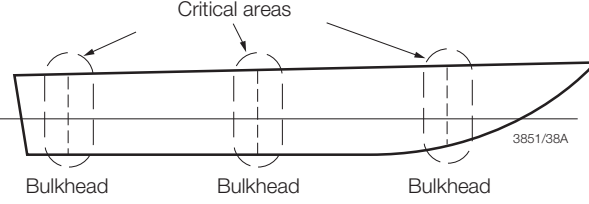
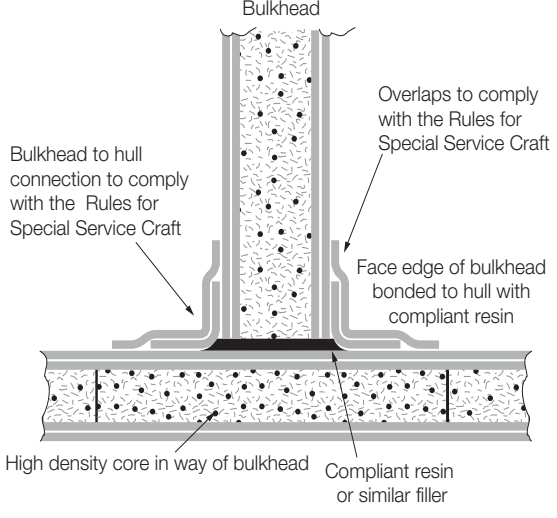
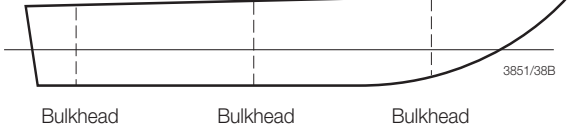
<p>AREA: Hull internal structure</p> <p>ITEM: Bulkhead to hull connection</p>		
CRITICAL AREAS	DETAIL DESIGN IMPROVEMENT	
<p>Sandwich construction, low speed</p>  	 <p>All bulkhead hull connections to comply with the Rules for Special Service Craft</p> 	
<p>NOTES</p> <p>Failure Mechanism Crushing of the sandwich core under the bulkhead, and delamination of the sandwich bulkhead due to excess loads arising from berthing, slinging, impact and racking.</p> <p>Building Tolerance All FRP material to comply with the Rules for Special Service Craft.</p> <p>Laminating Requirements To be in accordance with Part 8 of the Rules for Special Service Craft.</p>		
<p>GROUP 3</p>	<p>GUIDANCE NOTES FOR DESIGN DETAILS COMPOSITE CONSTRUCTION</p>	<p>FIGURE 10</p>

Detail Design Improvement for Composite Construction

Chapter 5

Section 2



AREA: Hull internal structure
 ITEM: Bulkhead to hull connection

CRITICAL AREAS

Sandwich construction, low speed

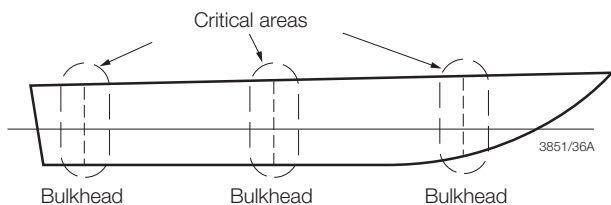
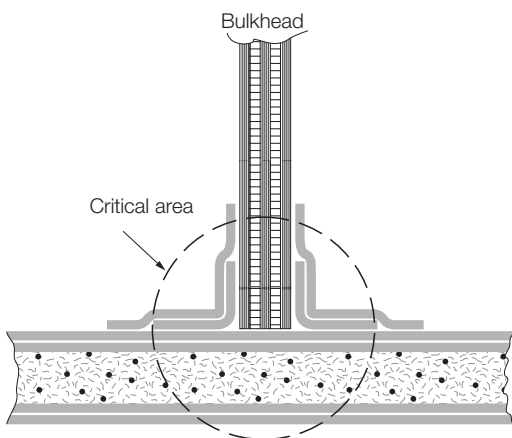

DETAIL DESIGN IMPROVEMENT

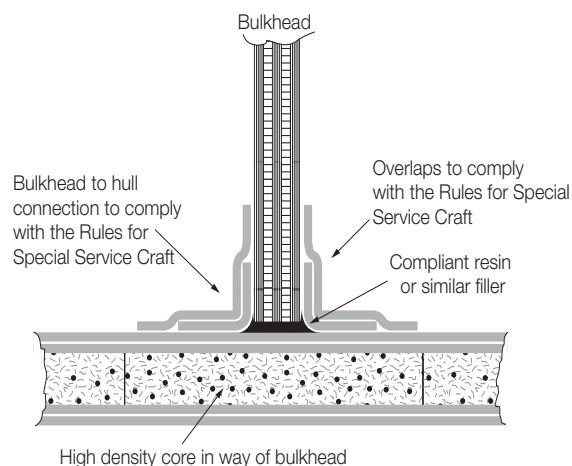

All bulkhead hull connections to comply with the Rules for Special Service Craft

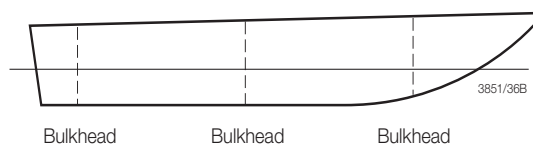

NOTES

- Failure Mechanism** Crushing of the sandwich core under the bulkhead due to excess loads arising from berthing, slinging, impact and racking.
- Building Tolerance** All FRP material to comply with the Rules for Special Service Craft.
- Laminating Requirements** To be in accordance with Part 8 of the Rules for Special Service Craft.

GROUP
3

GUIDANCE NOTES FOR DESIGN DETAILS
COMPOSITE CONSTRUCTION

FIGURE
11

Detail Design Improvement for Composite Construction

Chapter 5

Section 2



AREA: Hull bottom structure
 ITEM: Bulkhead to hull connection

CRITICAL AREAS

Single skin construction, low speed

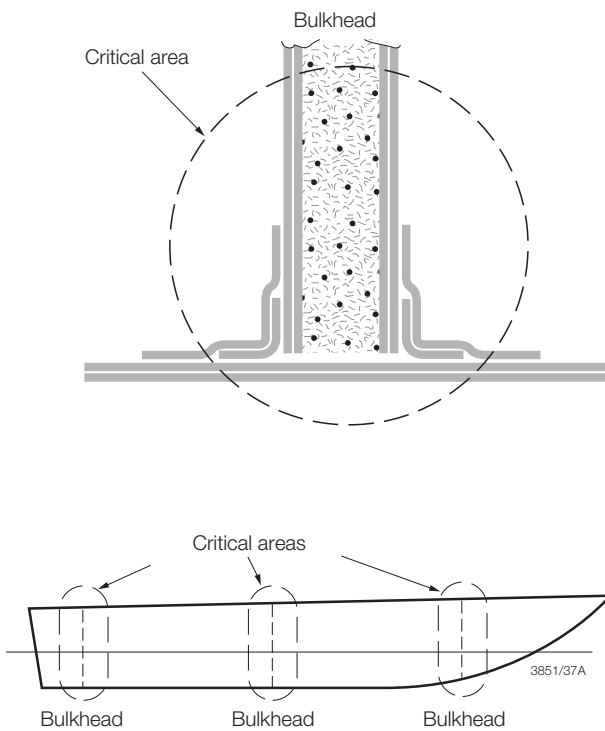

DETAIL DESIGN IMPROVEMENT

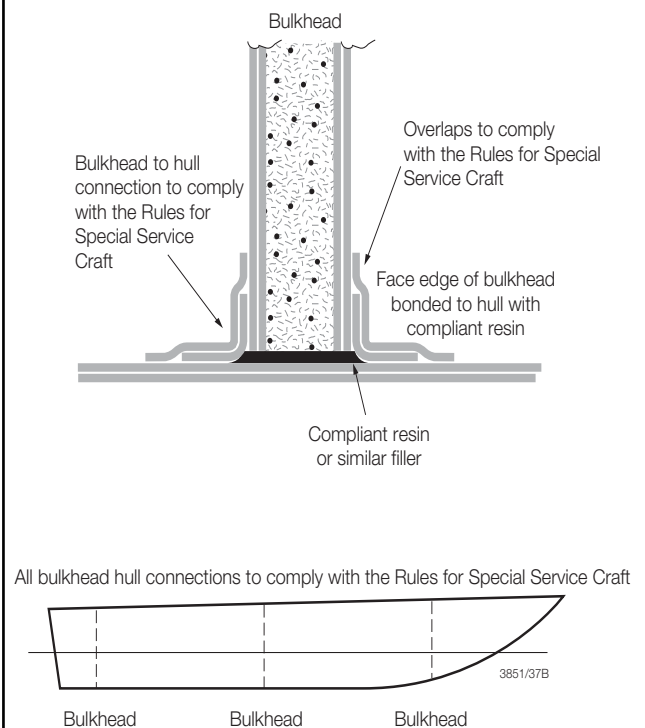

NOTES

- Failure Mechanism: Excess loads due to berthing, slinging, impact and racking.
- Building Tolerance: All FRP material to comply with the Rules for Special Service Craft.
- Laminating Requirements: To be in accordance with Part 8 of the Rules for Special Service Craft.

GROUP
4

GUIDANCE NOTES FOR DESIGN DETAILS
COMPOSITE CONSTRUCTION

FIGURE
12

Detail Design Improvement for Composite Construction

Chapter 5

Section 2



AREA: Hull bottom structure
 ITEM: Bulkhead to hull connection

CRITICAL AREAS

Single skin construction, low speed

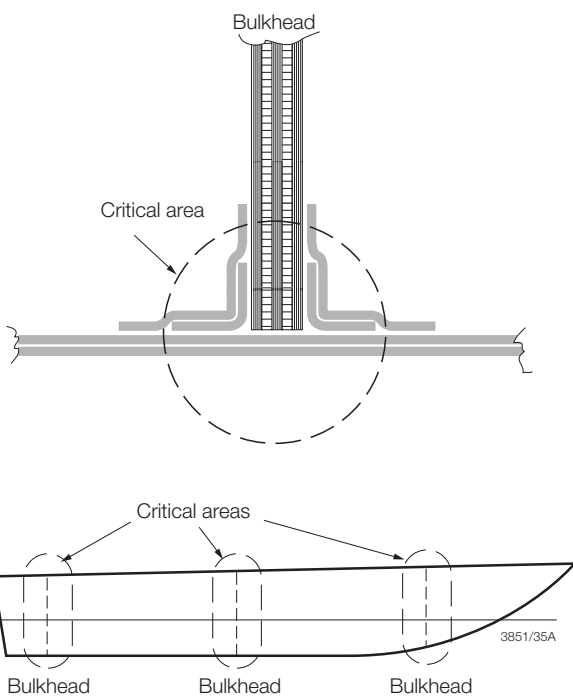

DETAIL DESIGN IMPROVEMENT

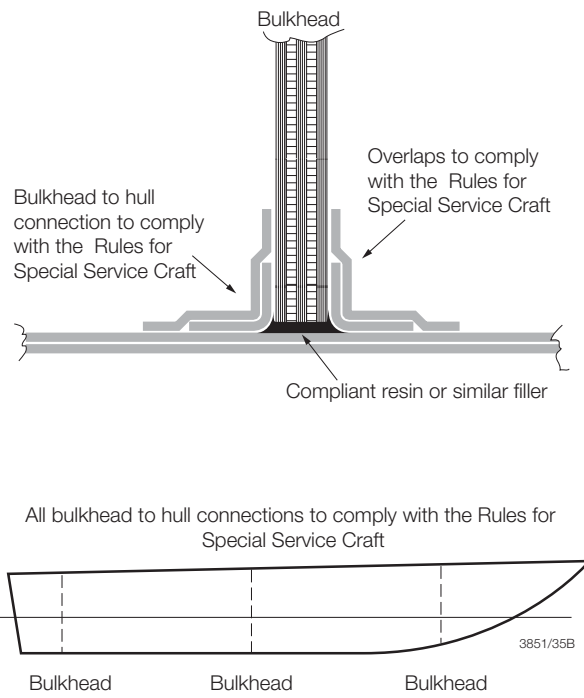

NOTES

- Failure Mechanism: Excess loads due to berthing, slinging, impact and racking.
- Building Tolerance: All FRP material to comply with the Rules for Special Service Craft.
- Laminating Requirements: To be in accordance with Part 8 of the Rules for Special Service Craft.

GROUP
4

GUIDANCE NOTES FOR DESIGN DETAILS
COMPOSITE CONSTRUCTION

FIGURE
13

Detail Design Improvement for Composite Construction

Chapter 5

Section 2

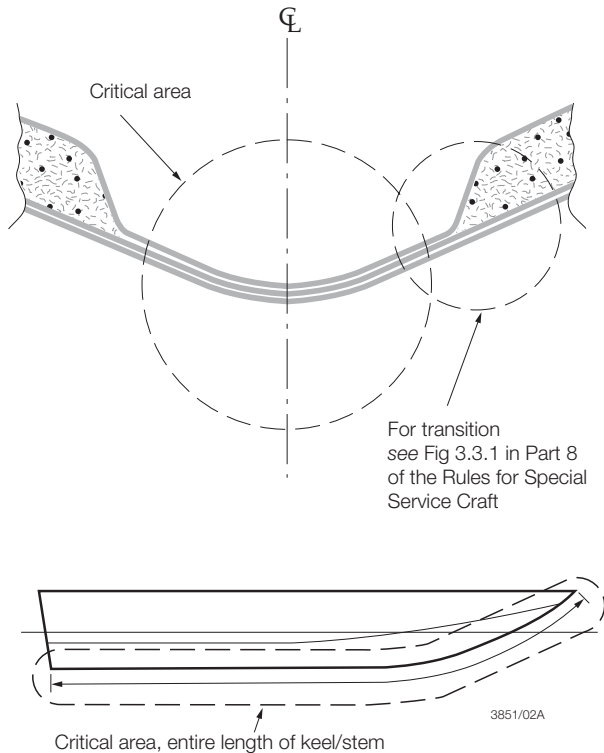
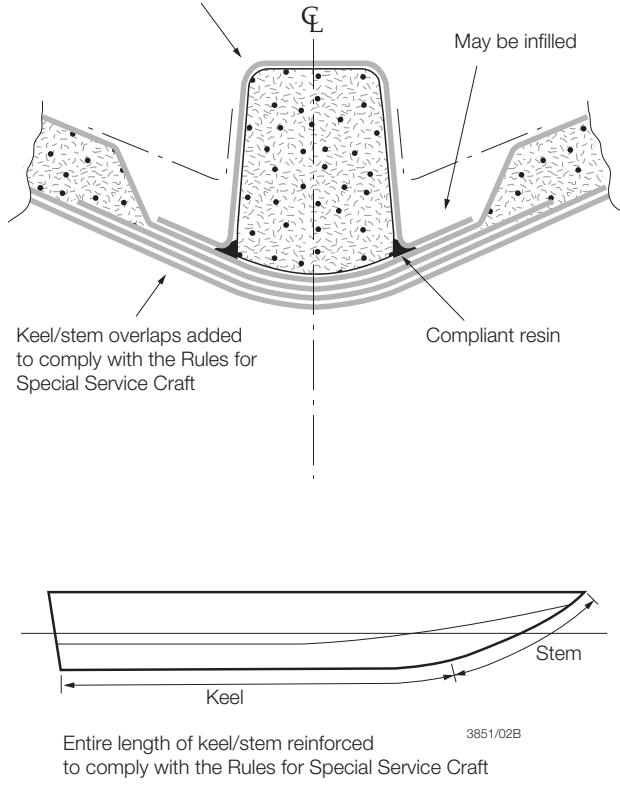
AREA: Hull centreline structure ITEM: Keel/stem reinforcement and keel stiffening		
CRITICAL AREAS		DETAIL DESIGN IMPROVEMENT
<p>Sandwich construction</p>  <p>For transition see Fig 3.3.1 in Part 8 of the Rules for Special Service Craft</p> <p>3851/02A</p>		<p>Centre line stiffener/girder added in way of keel to accommodate docking, grounding and slinging loads</p>  <p>Keel/stem overlaps added to comply with the Rules for Special Service Craft</p> <p>3851/02B</p>
<p>NOTES</p> <p>Failure Mechanism Excess loads due to grounding, docking and slinging.</p> <p>Building Tolerance All FRP materials to comply with the Rules for Special Service Craft.</p> <p>Laminating Requirements To be in accordance with the Part 8 of the Rules for Special Service Craft.</p>		
GROUP 5	GUIDANCE NOTES FOR DESIGN DETAILS COMPOSITE CONSTRUCTION	FIGURE 14

Detail Design Improvement for Composite Construction

Chapter 5

Section 2

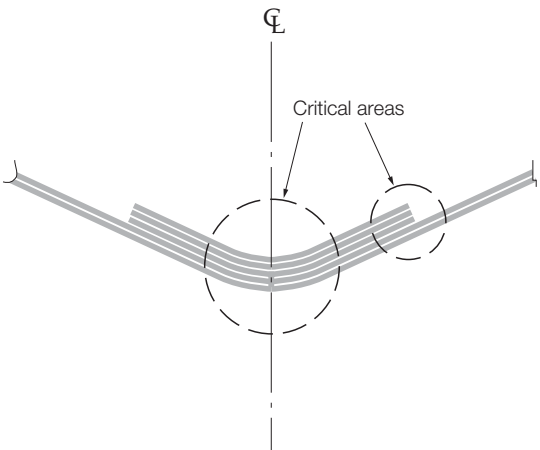
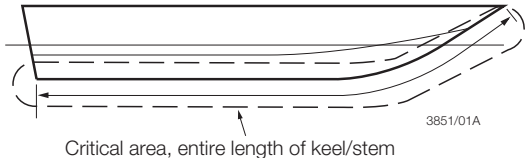
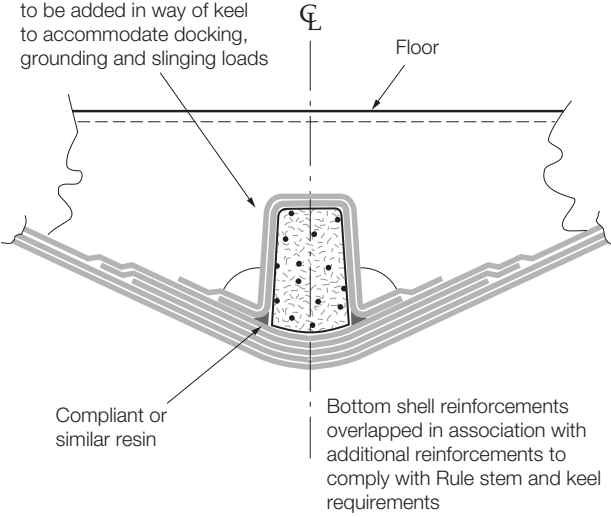
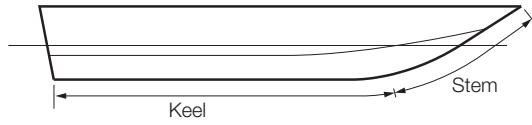
<p>AREA: Hull centreline structure</p> <p>ITEM: Keel/stem reinforcement and keel stiffening</p>		
CRITICAL AREAS	DETAIL DESIGN IMPROVEMENT	
<p>Single skin construction</p>   <p style="text-align: center;">Critical area, entire length of keel/stem</p> <p style="text-align: right;">3851/01A</p>	<p>Where a skeg is not fitted a centre line stiffener/girder is to be added in way of keel to accommodate docking, grounding and slinging loads</p>   <p style="text-align: center;">Entire Length of keel/stem reinforced to comply with the Rules for Special Service Craft</p> <p style="text-align: right;">3851/01B</p>	
<p>NOTES</p> <p>Failure Mechanism Excess loads due to grounding, docking and slinging.</p> <p>Building Tolerance All FRP materials to comply with the Rules for Special Service Craft.</p> <p>Laminating Requirements To be in accordance with Part 8 of the Rules for Special Service Craft.</p>		
GROUP 5	GUIDANCE NOTES FOR DESIGN DETAILS COMPOSITE CONSTRUCTION	FIGURE 15

Detail Design Improvement for Composite Construction

Chapter 5

Section 2

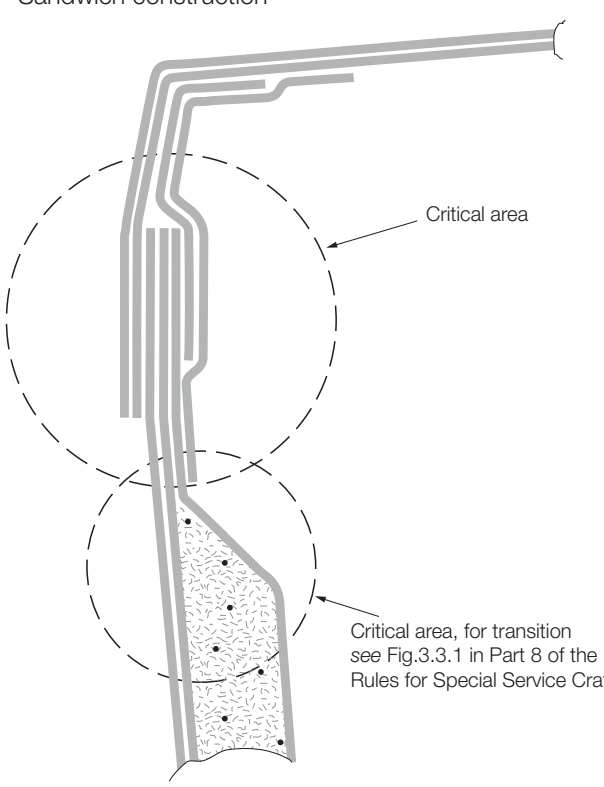
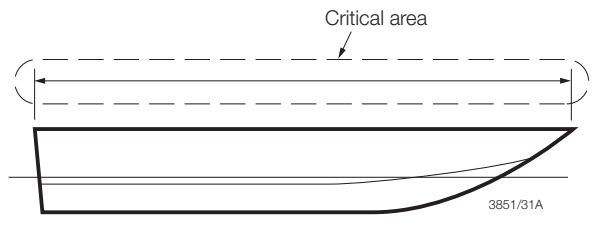
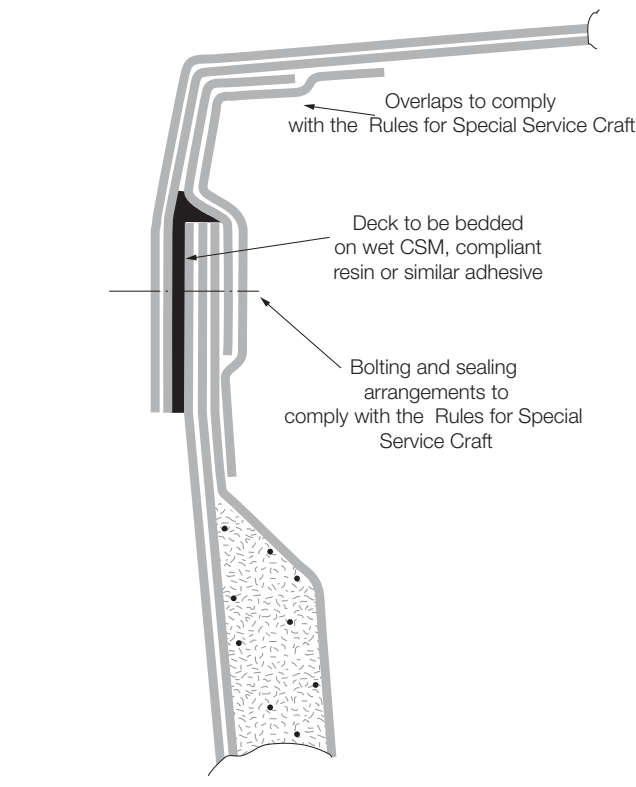
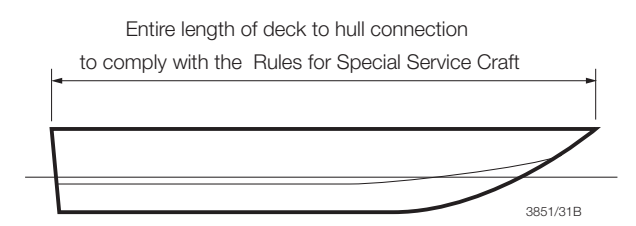
AREA: Hull structure ITEM: Deck to hull connection		
CRITICAL AREAS	DETAIL DESIGN IMPROVEMENT	
<p>Sandwich construction</p>   <p style="text-align: right;">3851/31A</p>	  <p style="text-align: right;">3851/31B</p>	
<p>NOTES</p> <p>Failure Mechanism Excess loads due to berthing, slinging, impact from green seas and other loadings arising from heavy weather.</p> <p>Building Tolerance All FRP material to comply with the Rules for Special Service Craft.</p> <p>Laminating Requirements To be in accordance with Part 8 of the Rules for Special Service Craft.</p>		
GROUP 5	GUIDANCE NOTES FOR DESIGN DETAILS COMPOSITE CONSTRUCTION	FIGURE 16

Detail Design Improvement for Composite Construction

Chapter 5

Section 2



AREA: Hull structure
ITEM: Transom boundary

CRITICAL AREAS

Single skin construction

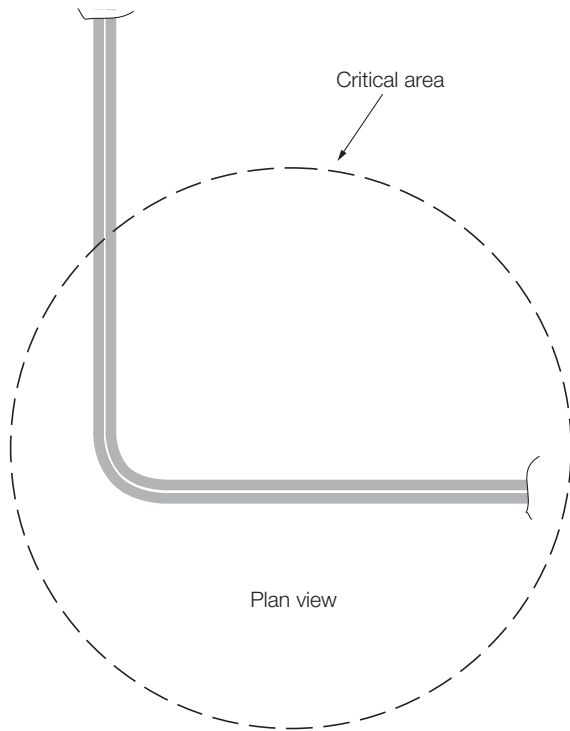

Critical area, entire length of transom boundary

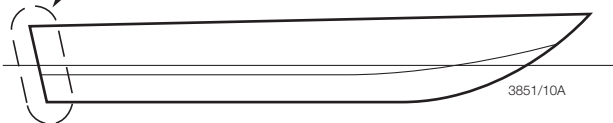

DETAIL DESIGN IMPROVEMENT

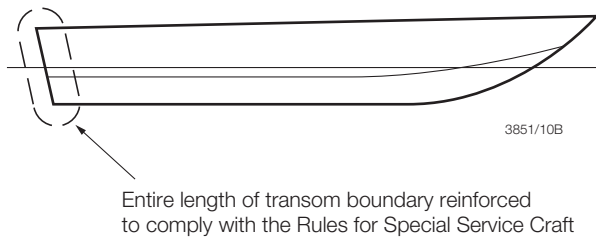
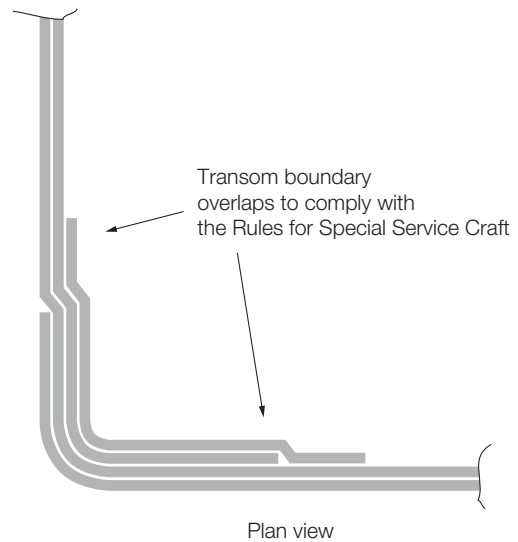

NOTES

- Failure Mechanism: Excess loads due to docking and impact due to berthing.
- Building Tolerance: All FRP materials to comply with the Rules for Special Service Craft.
- Laminating Requirements: To be in accordance with Part 8 of the Rules for Special Service Craft.

GROUP 5

GUIDANCE NOTES FOR DESIGN DETAILS
COMPOSITE CONSTRUCTION

FIGURE 17

Detail Design Improvement for Composite Construction

Chapter 5

Section 2

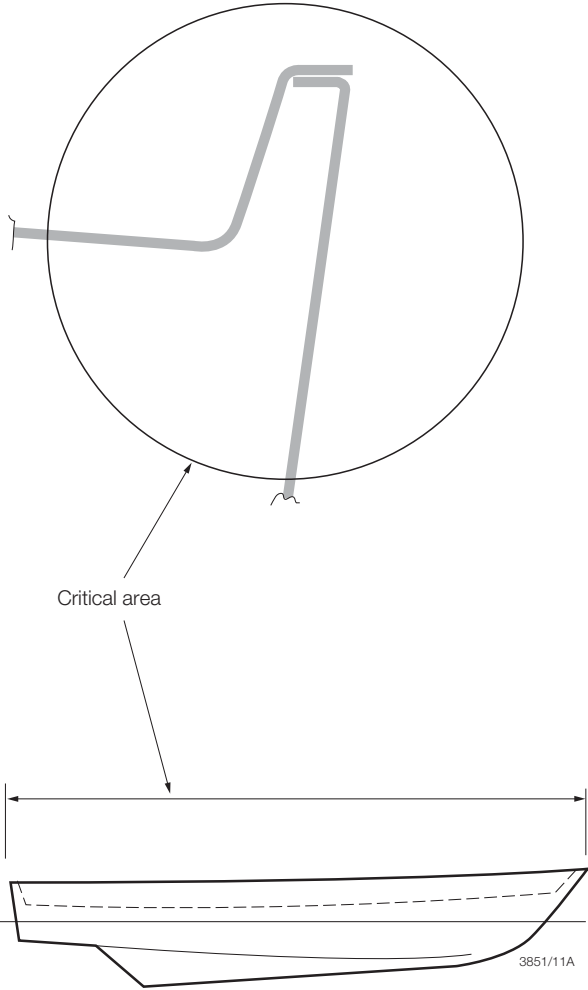
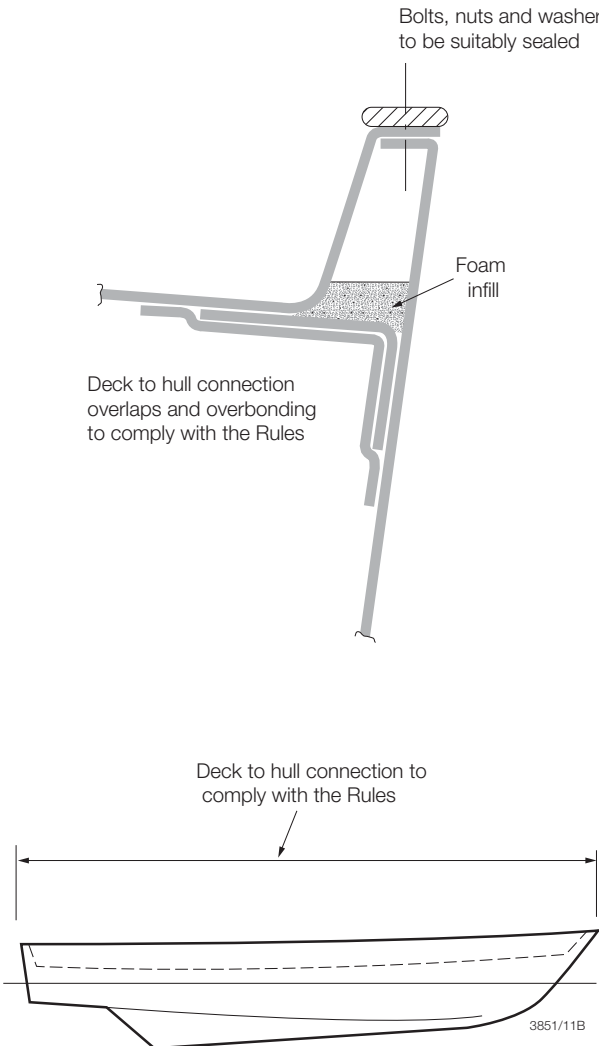
<p>AREA: Hull structure</p> <p>ITEM: Deck to hull connection</p>	 <p>Lloyd's Register</p>	
CRITICAL AREAS	DETAIL DESIGN IMPROVEMENT	
<p>Single skin construction</p>  <p>Critical area</p> <p>3851/11A</p>	 <p>Bolts, nuts and washers to be suitably sealed</p> <p>Foam infill</p> <p>Deck to hull connection overlaps and overbonding to comply with the Rules</p> <p>Deck to hull connection to comply with the Rules</p> <p>3851/11B</p>	
<p>NOTES</p> <p>Failure Mechanism Excess loads due to berthing, slinging, impact from green seas and other loadings arising from heavy weather.</p> <p>Building Tolerance All FRP material to comply with the Rules for Special Service Craft.</p> <p>Laminating Requirements To be in accordance with Part 8 of the Rules for Special Service Craft.</p>		
<p>GROUP 5</p>	<p>GUIDANCE NOTES FOR DESIGN DETAILS COMPOSITE CONSTRUCTION</p>	<p>FIGURE 18</p>

Detail Design Improvement for Composite Construction

Chapter 5

Section 2



AREA: Hull bottom structure

ITEM: Limber holes

CRITICAL AREAS

Single skin construction

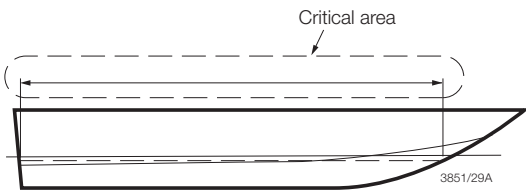
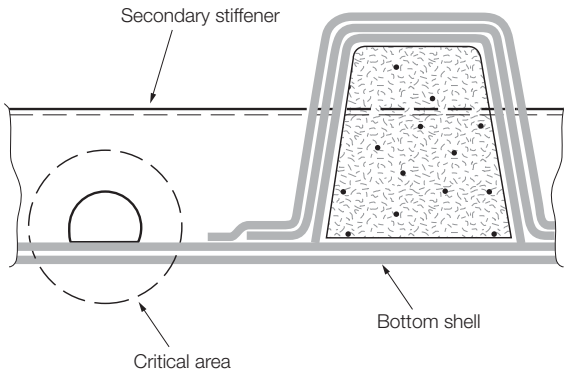

DETAIL DESIGN IMPROVEMENT

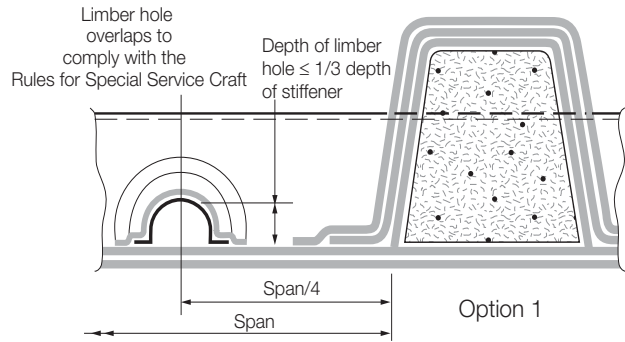

Option 1

FRP preform bonded to shell and stiffener with compliant resin adhesive

NOTE: PVC preforms to be overlaminated to shell before installation of stiffener

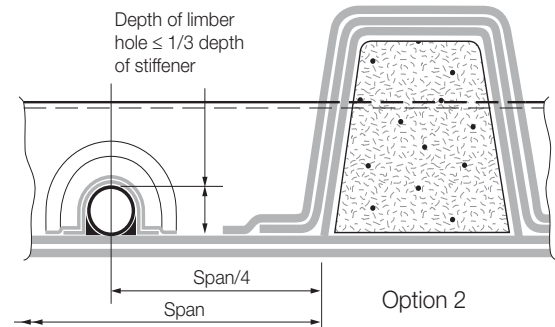

Option 2

All limber holes to comply with the Rules for Special Service Craft



NOTES

Failure Mechanism	Excess loads due to hydrodynamic impact, grounding, docking and slinging leading to stiffener web failure.
Building Tolerance	All FRP materials to be in accordance with the Rules for Special Service Craft.
Laminating Requirements	To be in accordance with Part 8 of the Rules for Special Service Craft.

GROUP
5

GUIDANCE NOTES FOR DESIGN DETAILS
COMPOSITE CONSTRUCTION

FIGURE
19

Detail Design Improvement for Composite Construction

Chapter 5

Section 2

AREA:	Hull bottom structure	
ITEM:	Machinery seating, tapping plates	

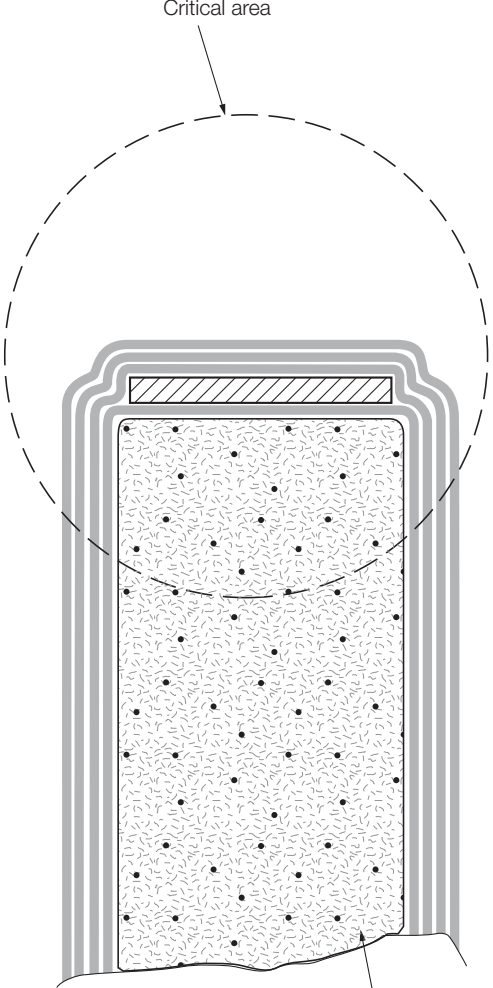
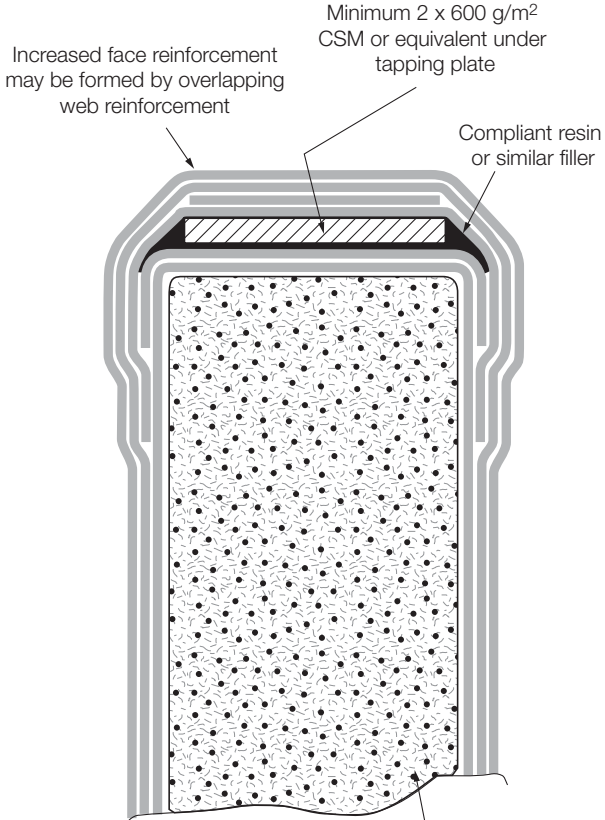
CRITICAL AREAS	DETAIL DESIGN IMPROVEMENT
 <p style="text-align: center;">Critical area</p> <p style="text-align: center;">Non structural foam core</p> <p style="text-align: center;">3851/28A</p>	 <p style="text-align: center;">Increased face reinforcement may be formed by overlapping web reinforcement</p> <p style="text-align: center;">Minimum 2 x 600 g/m² CSM or equivalent under tapping plate</p> <p style="text-align: center;">Compliant resin or similar filler</p> <p style="text-align: center;">Structural foam core</p> <p style="text-align: center;">3851/28B</p> <p style="text-align: center;">Tapping plate is to be suitably abraded, all sharp edges removed and all corners radiused prior to encapsulating</p>

NOTES	
Failure Mechanism	Engine loadings arising from thrust, torque and mass.
Building Tolerance	All FRP materials to comply with the Rules for Special Service Craft.
Laminating Requirements	To be in accordance with Part 8 of the Rules for Special Service Craft.

GROUP 5	GUIDANCE NOTES FOR DESIGN DETAILS COMPOSITE CONSTRUCTION	FIGURE 20
------------	---	--------------

Detail Design Improvement for Composite Construction

Chapter 5

Section 2



AREA: Hull internal structure
 ITEM: Deep girders and floors

CRITICAL AREAS

Sandwich construction/single skin construction

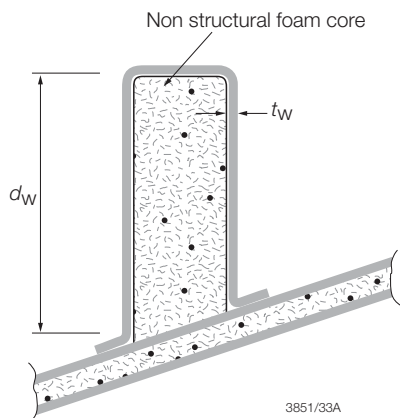

t_w is to satisfy the Rule requirement for d_w , see Pt 8, Ch 2,5.9 of the Rules for Special Service Craft

d_w = unsupported web depth
 t_w = web thickness

DETAIL DESIGN IMPROVEMENT

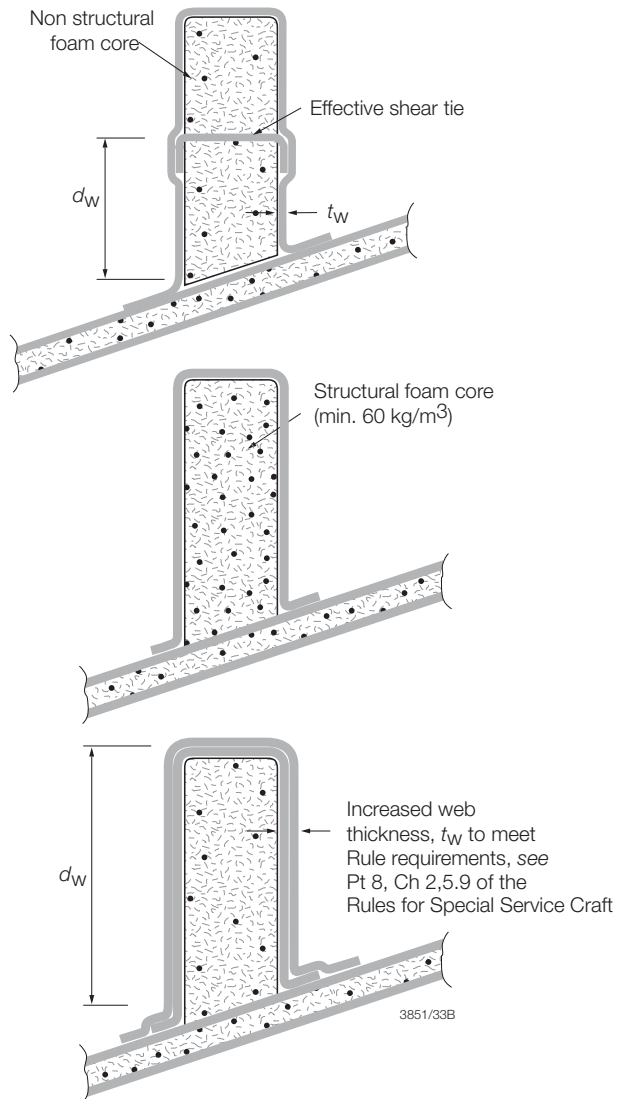

NOTES

- Failure Mechanism: Web buckling under design load, docking and berthing loads.
- Building Tolerance: All FRP material to comply with the Rules for Special Service Craft.
- Laminating Requirements: To be in accordance with Part 8 of the Rules for Special Service Craft.

GROUP
5

GUIDANCE NOTES FOR DESIGN DETAILS
COMPOSITE CONSTRUCTION

FIGURE
21

Detail Design Improvement for Composite Construction

Chapter 5

Section 2

AREA:	Hull internal structure	
ITEM:	'Top-hat' stiffeners penetrating tank boundaries	

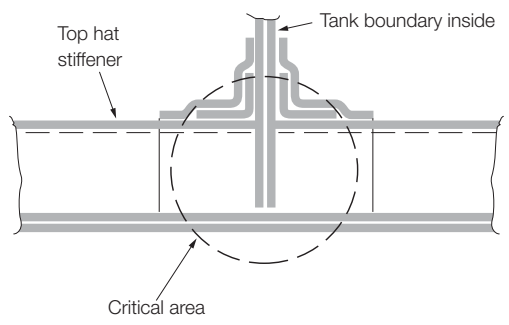
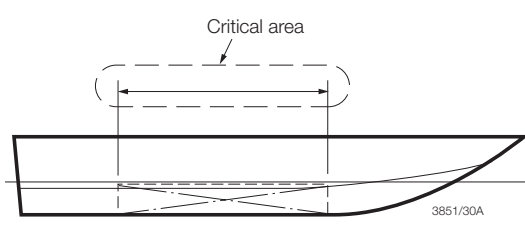
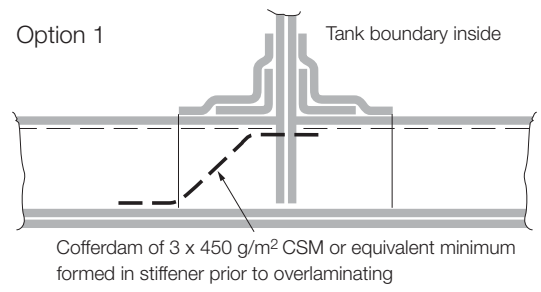
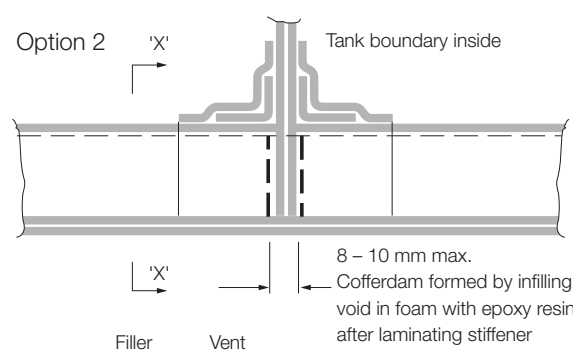
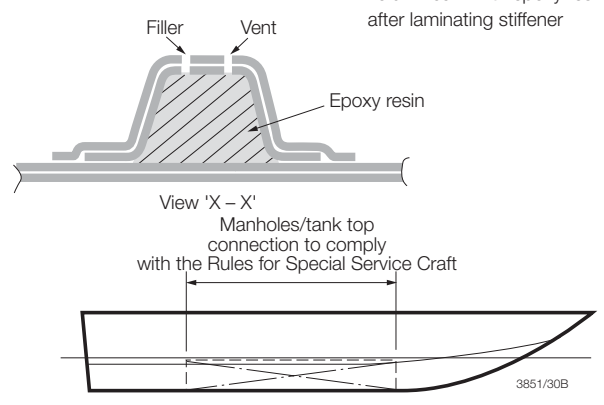
CRITICAL AREAS	DETAIL DESIGN IMPROVEMENT
 	<p>Option 1</p>  <p>Option 2</p>   <p>View 'X - X' Manholes/tank top connection to comply with the Rules for Special Service Craft</p>

NOTES	
Failure Mechanism	Ingress and permeation of fluid along stiffener.
Building Tolerance	All FRP material to comply with the Rules for Special Service Craft. Fit-up is to be very good.
Laminating Requirements	To be in accordance with Part 8 of the Rules for Special Service Craft.

GROUP 5	GUIDANCE NOTES FOR DESIGN DETAILS COMPOSITE CONSTRUCTION	FIGURE 22
------------	---	--------------

Detail Design Improvement for Composite Construction

Chapter 5

Section 2

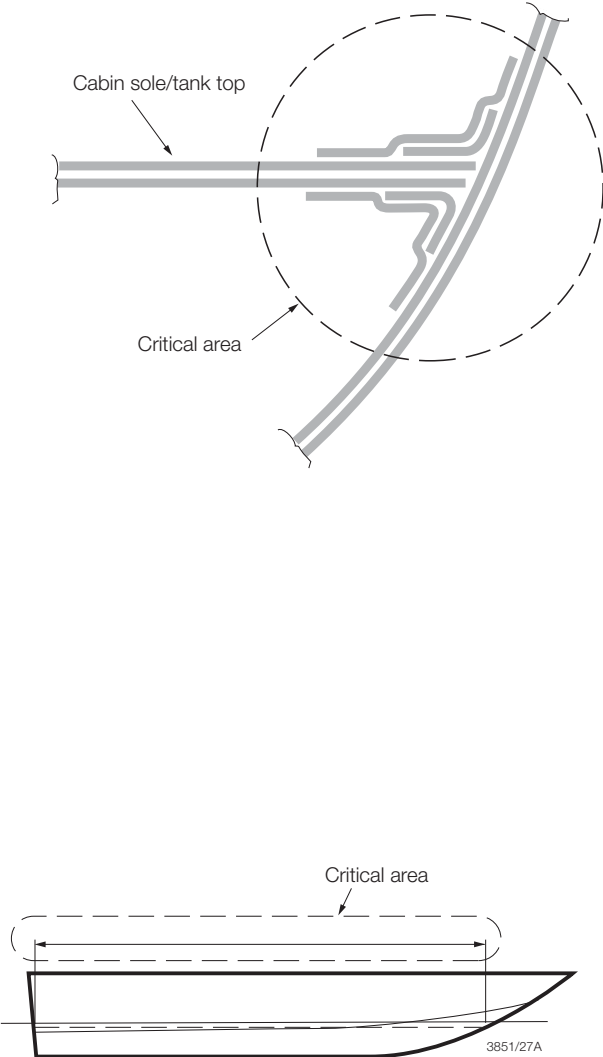
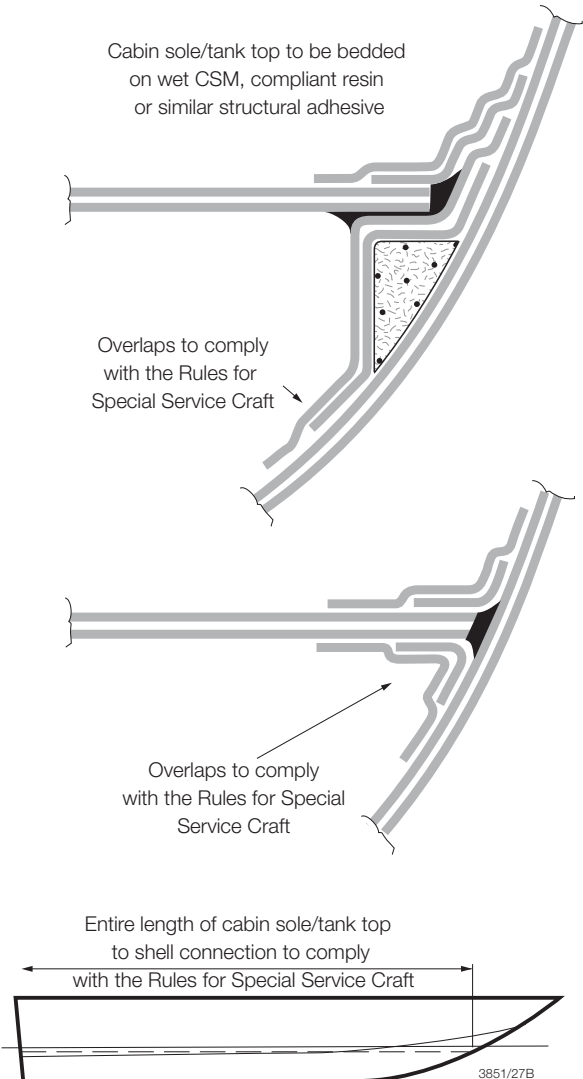
<p>AREA: Hull internal structure</p> <p>ITEM: Lower deck/tank top to bottom shell connection</p>		
CRITICAL AREAS	DETAIL DESIGN IMPROVEMENT	
<p>Single skin construction</p>  <p style="text-align: right;">3851/27A</p>	<p>Cabin sole/tank top to be bedded on wet CSM, compliant resin or similar structural adhesive</p>  <p style="text-align: right;">3851/27B</p>	
<p>NOTES</p> <p>Failure Mechanism Excess loads due to impact also hydrostatic pressure where the internal structure forms the boundary of an integral tank.</p> <p>Building Tolerance All FRP materials to comply with the Rules for Special Service Craft.</p> <p>Laminating Requirements To be in accordance with Part 8 of the Rules for Special Service Craft.</p>		
<p>GROUP 5</p>	<p>GUIDANCE NOTES FOR DESIGN DETAILS COMPOSITE CONSTRUCTION</p>	<p>FIGURE 23</p>

Detail Design Improvement for Composite Construction

Chapter 5

Section 2



AREA: Hull internal structure
 ITEM: Integral tanks access manholes

CRITICAL AREAS

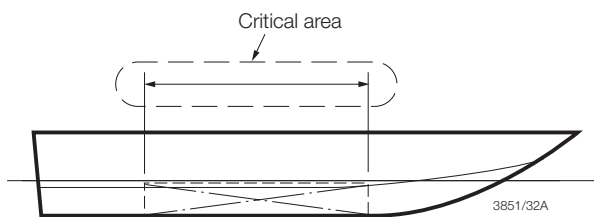
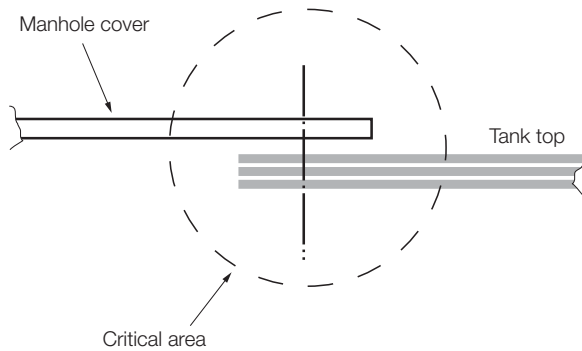

DETAIL DESIGN IMPROVEMENT

Manhole cover bolted to tank top with bolts spaced at not greater than 8 diameter centres

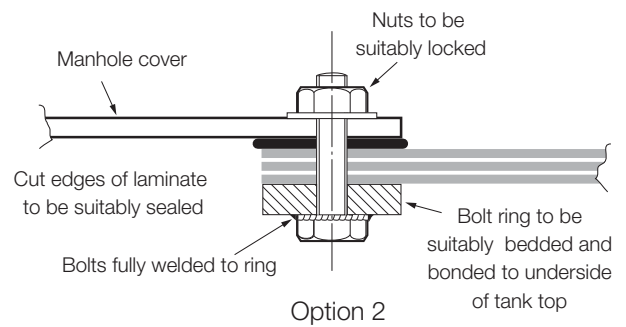
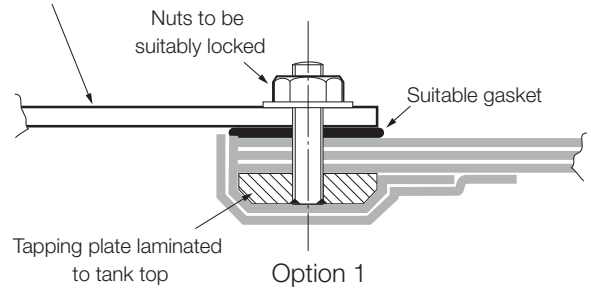

Manholes/tank top connection to comply with the Rules for Special Service Craft

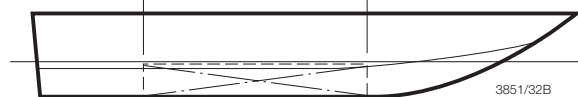

NOTES

- Failure Mechanism: Leakage under hydrostatic pressure.
- Building Tolerance: All FRP material to comply with the Rules for Special Service Craft.
- Laminating Requirements: To be in accordance with Part 8 of the Rules for Special Service Craft.

GROUP 5

GUIDANCE NOTES FOR DESIGN DETAILS
 COMPOSITE CONSTRUCTION

FIGURE 24

Detail Design Improvement for Composite Construction

Chapter 5

Section 2



AREA: Skeg (open type)
 ITEM: Skeg stiffening and reinforcement

CRITICAL AREAS

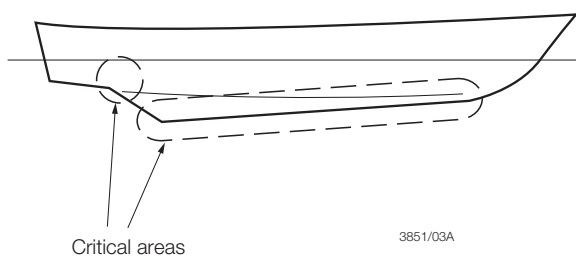
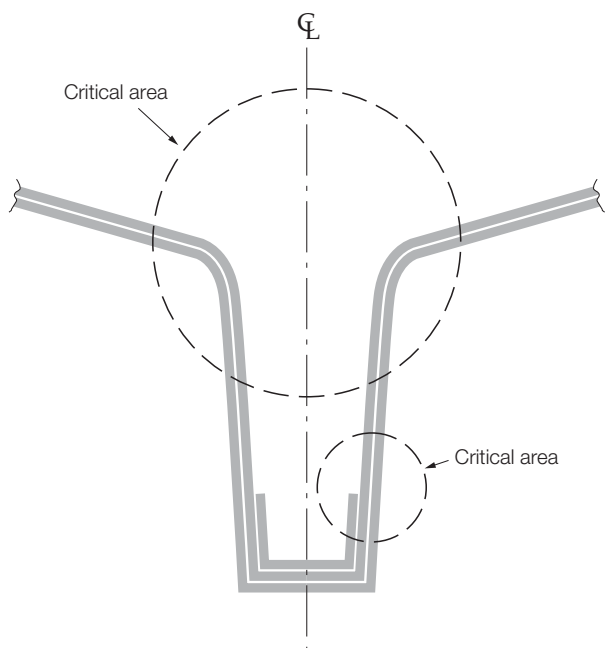

3851/03A

DETAIL DESIGN IMPROVEMENT

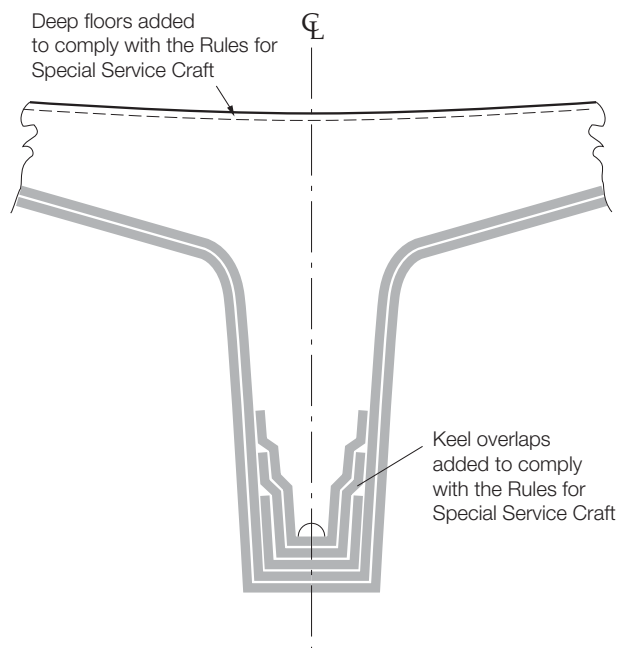

Note : Where the hull is moulded in two halves, the bottom shell laminate is to be reinstated across CL prior to additional reinforcements to comply with the Rule keel requirements.



3851/03B

NOTES

Failure Mechanism	Excess loads due to grounding, docking, slinging and hydrostatic pressure.
Building Tolerance	All FRP materials to comply with the Rules for Special Service Craft.
Laminating Requirements	To be in accordance with Part 8 of the Rules for Special Service Craft.

GROUP
5

GUIDANCE NOTES FOR DESIGN DETAILS
COMPOSITE CONSTRUCTION

FIGURE
25

Detail Design Improvement for Composite Construction

Chapter 5

Section 2

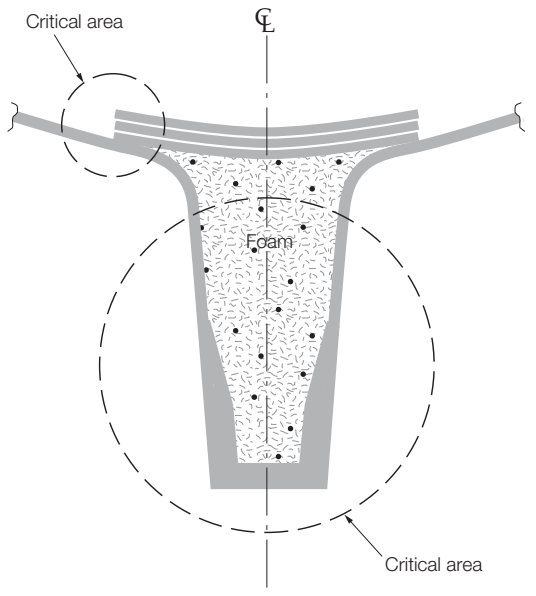
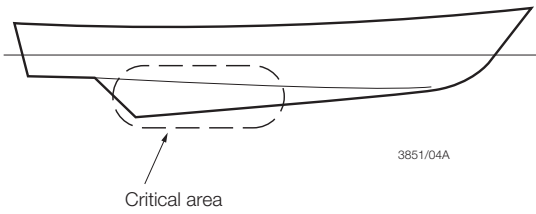
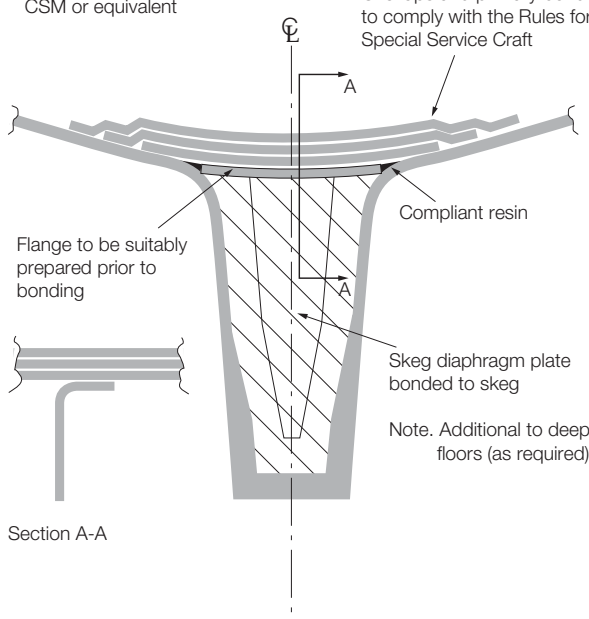
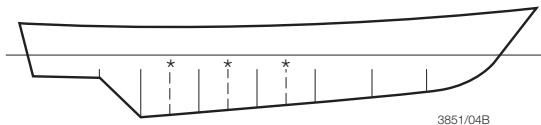
<p>AREA: Skeg (closed type)</p> <p>ITEM: Skeg diaphragm plates and sealing laminate</p>		
CRITICAL AREAS	DETAIL DESIGN IMPROVEMENT	
  <p style="text-align: right;">3851/04A</p>	<p>Skeg foam sealing as SSC Rules but not to be less than 3 x 600 g/m² CSM or equivalent</p> <p>Overlaps and primary bonding to comply with the Rules for Special Service Craft</p>  <p>Flange to be suitably prepared prior to bonding</p> <p>Note. Additional to deep floors (as required)</p>  <p style="text-align: right;">3851/04B</p> <p>* Skeg diaphragm plates added as required to ensure that skeg panel sizes comply with the Rules for Special Service Craft</p>	
<p>NOTES</p> <p>Failure Mechanism Excess loads due to grounding, docking, slinging and hydrostatic pressure both externally and internally in the case of integral tanks.</p> <p>Building Tolerance To align with bottom framing. All FRP materials to comply with the Rules for Special Service Craft.</p> <p>Laminating Requirements To be in accordance with Part 8 of the Rules for Special Service Craft.</p>		
GROUP 5	GUIDANCE NOTES FOR DESIGN DETAILS COMPOSITE CONSTRUCTION	FIGURE 26

Detail Design Improvement for Composite Construction

Chapter 5

Section 2

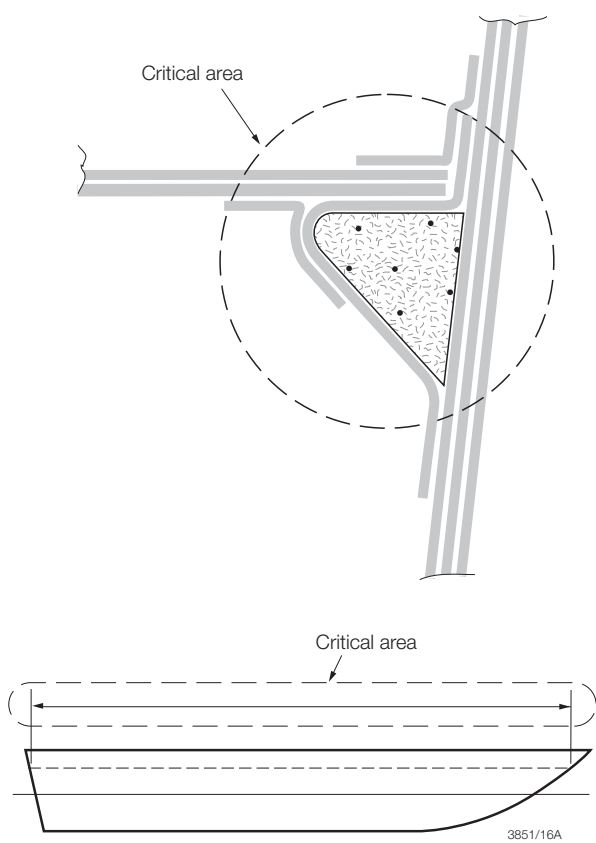
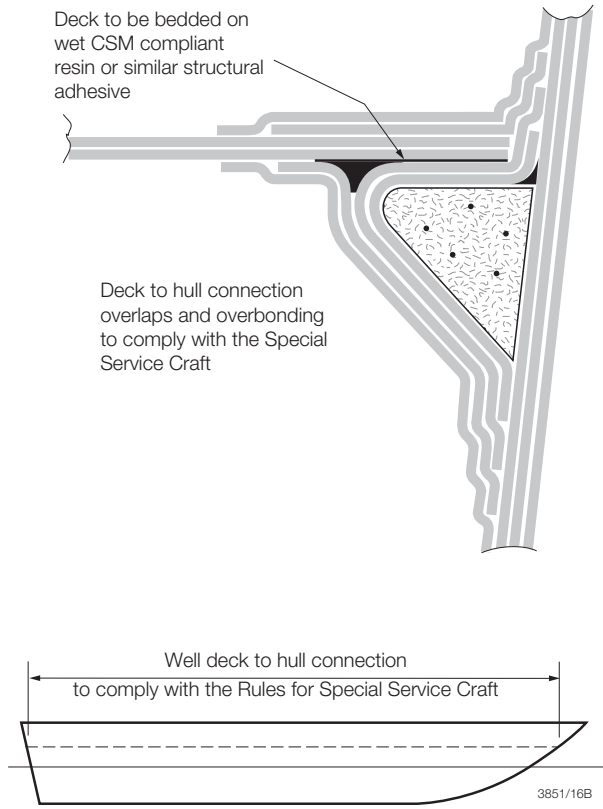
<p>AREA: Deck structure</p> <p>ITEM: Well deck, lower/sole deck to hull connection</p>		
CRITICAL AREAS	DETAIL DESIGN IMPROVEMENT	
		
<p>NOTES</p> <p>Failure Mechanism Excess loads due to berthing and slinging.</p> <p>Building Tolerance All FRP material to comply with the Rules for Special Service Craft.</p> <p>Laminating Requirements To be in accordance with Part 8 of the Rules for Special Service Craft.</p>		
<p>GROUP 5</p>	<p>GUIDANCE NOTES FOR DESIGN DETAILS COMPOSITE CONSTRUCTION</p>	<p>FIGURE 27</p>

Detail Design Improvement for Composite Construction

Chapter 5

Section 2

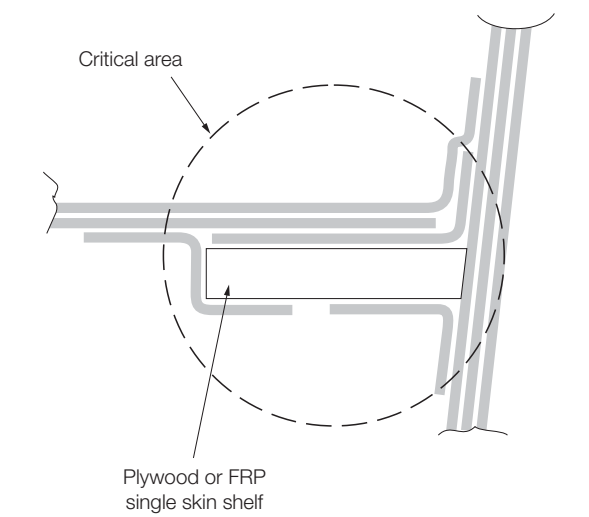
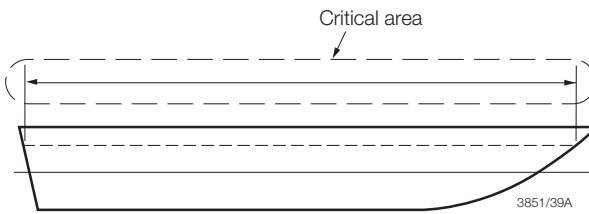
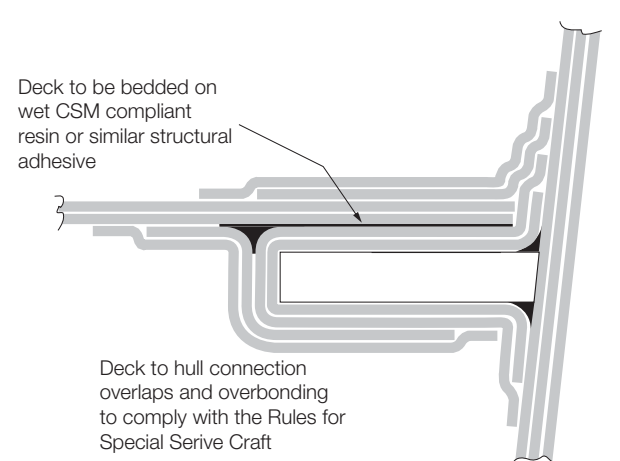
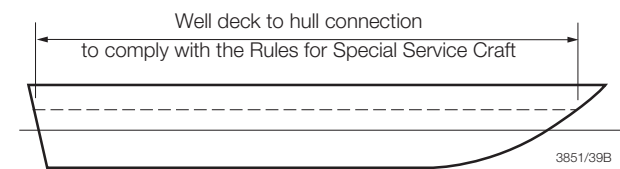
<p>AREA: Deck structure</p> <p>ITEM: Well deck, lower/sole deck to hull connection</p>		
CRITICAL AREAS	DETAIL DESIGN IMPROVEMENT	
 <p style="text-align: center;">Critical area</p> <p style="text-align: center;">Plywood or FRP single skin shelf</p>  <p style="text-align: center;">Critical area</p> <p style="text-align: right;">3851/39A</p>	 <p>Deck to be bedded on wet CSM compliant resin or similar structural adhesive</p> <p>Deck to hull connection overlaps and overbonding to comply with the Rules for Special Service Craft</p>  <p style="text-align: center;">Well deck to hull connection to comply with the Rules for Special Service Craft</p> <p style="text-align: right;">3851/39B</p>	
<p>NOTES</p> <p>Failure Mechanism Excess loads due to berthing and slinging.</p> <p>Building Tolerance All FRP material to comply with the Rules for Special Service Craft.</p> <p>Laminating Requirements To be in accordance with Part 8 of the Rules for Special Service Craft.</p>		
<p>GROUP 5</p>	<p>GUIDANCE NOTES FOR DESIGN DETAILS COMPOSITE CONSTRUCTION</p>	<p>FIGURE 28</p>

Detail Design Improvement for Composite Construction

Chapter 5

Section 2

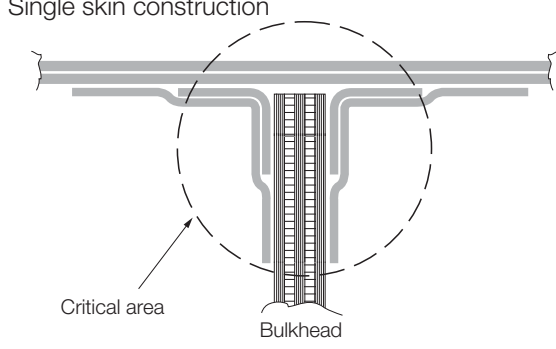
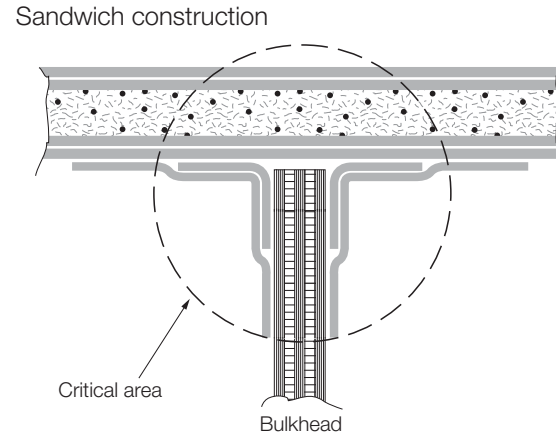
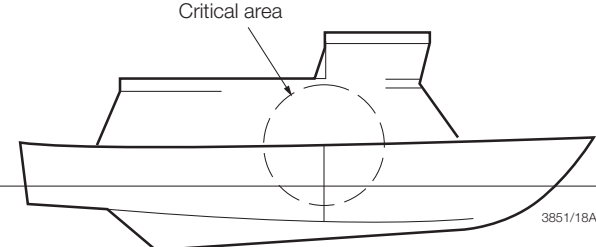
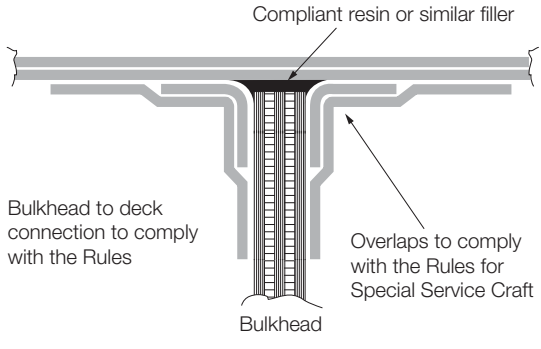
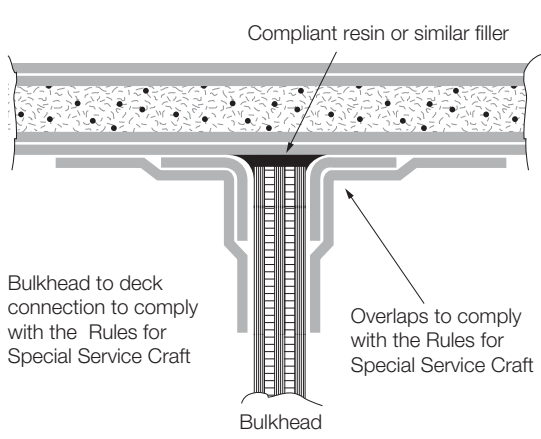
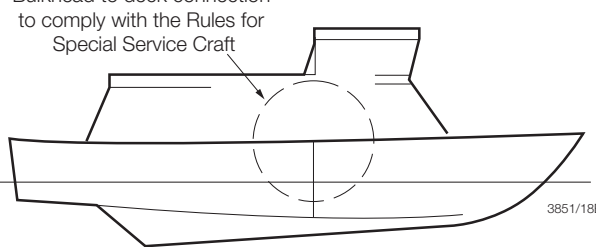

AREA: Deck
ITEM: Bulkhead to deck connection

CRITICAL AREAS	DETAIL DESIGN IMPROVEMENT
<p>Single skin construction</p>  <p>Sandwich construction</p>  	<p>Compliant resin or similar filler</p>  <p>Bulkhead to deck connection to comply with the Rules</p> <p>Overlaps to comply with the Rules for Special Service Craft</p> <p>Bulkhead</p> <p>Compliant resin or similar filler</p>  <p>Bulkhead to deck connection to comply with the Rules for Special Service Craft</p> <p>Overlaps to comply with the Rules for Special Service Craft</p> <p>Bulkhead</p> <p>Bulkhead to deck connection to comply with the Rules for Special Service Craft</p> 

NOTES

- Failure Mechanism: Excess loads due to berthing, slinging and impact.
- Building Tolerance: All FRP material to comply with the Rules for Special Service Craft. Alignment and fit to be good, all gaps to be filled.
- Laminating Requirements: To be in accordance with Part 8 of the Rules for Special Service Craft.

GROUP 5

GUIDANCE NOTES FOR DESIGN DETAILS
COMPOSITE CONSTRUCTION

FIGURE 29

Detail Design Improvement for Composite Construction

Chapter 5

Section 2



AREA: Deck
 ITEM: Deckhouse to deck connection

CRITICAL AREAS

Single skin deck construction

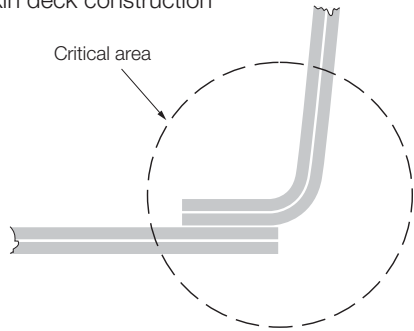

Sandwich deck construction

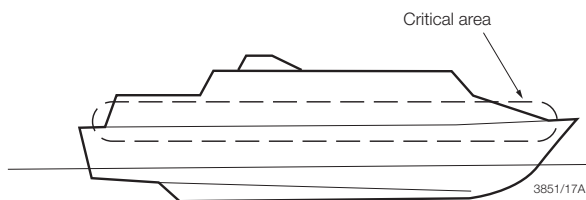
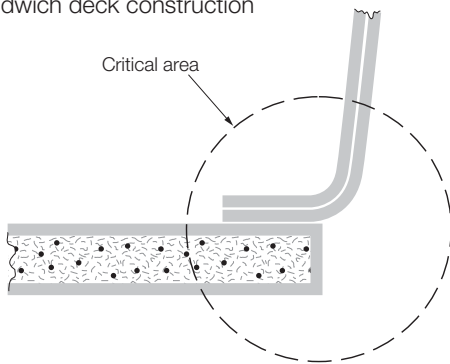

DETAIL DESIGN IMPROVEMENT

Deckhouse to deck connection to comply with the Rules for Special Service Craft

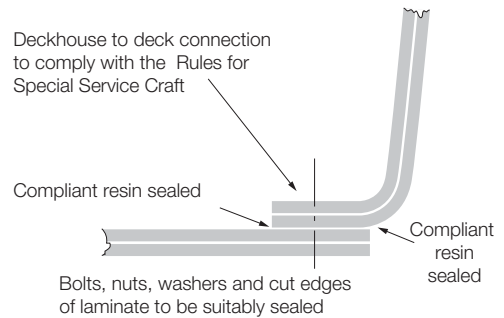

Deckhouse to deck connection to comply with the Rules for Special Service Craft

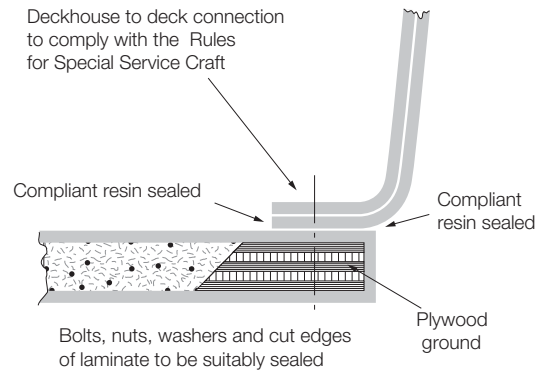

Deckhouse to deck connection to comply with the Rules for Special Service Craft

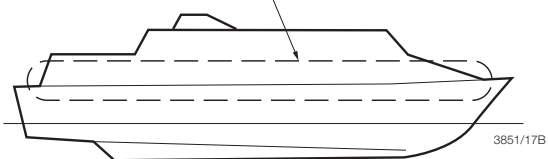

NOTES

Failure Mechanism	Excess loads due to berthing, slinging, impact from green seas and other loads arising from heavy weather.
Building Tolerance	All FRP material to comply with the Rules for Special Service Craft.
Laminating Requirements	To be in accordance with Part 8 of the Rules for Special Service Craft.

GROUP 5

GUIDANCE NOTES FOR DESIGN DETAILS
 COMPOSITE CONSTRUCTION

FIGURE 30

© Lloyd's Register Group Limited 2014
Published by Lloyd's Register Group Limited
Registered office (Reg. no. 08126909)
71 Fenchurch Street, London, EC3M 4BS
United Kingdom