

Basics of Geophysical Well Logs: Porosity

Porosity Logs

Porosity (F), can be defined as the ratio between the volume of the pores and the total rock volume.

Porosity defines the formation fluid storage capabilities of the reservoir.

Well logs allow the in-situ, indirect evaluation of the formation porosity. The most used ones are:

- **Density**
- **Neutron**
- **Sonic**
- **Nuclear Magnetic Resonance**

Since all these measurements are influenced by formation fluids and minerals of the matrix, these logs are also used to identify the different lithologies.

Density log

The Density log measures the apparent density (RHOB) of the formation, by means of the interaction between the gamma rays emitted by a radioactive source and the rock.

The apparent density is affected by:

- density of the “matrix” of the rock,
- porosity of rock,
- density of the fluids that saturate the rock.

Applications of the density log are:

- in-situ evaluation of the porosity,
- in-situ lithological analysis,
- in-situ analysis of the fluids.

Density log

The Density Log allows the measurement, at in situ conditions, of the bulk density (ρ_b) subsurface formations.

The bulk density ρ_b is proportional to the Total Porosity of the rock (Φ_t) and, taking advantage of this relationship, it is possible to determine the porosity of the formation with high accuracy.

The primary measurement of porosity is the electronic density (ρ_e) of the rock which is proportional to ρ_b .

The physical principle used is the interaction between the Gamma Rays emitted by a GR source and the matter.

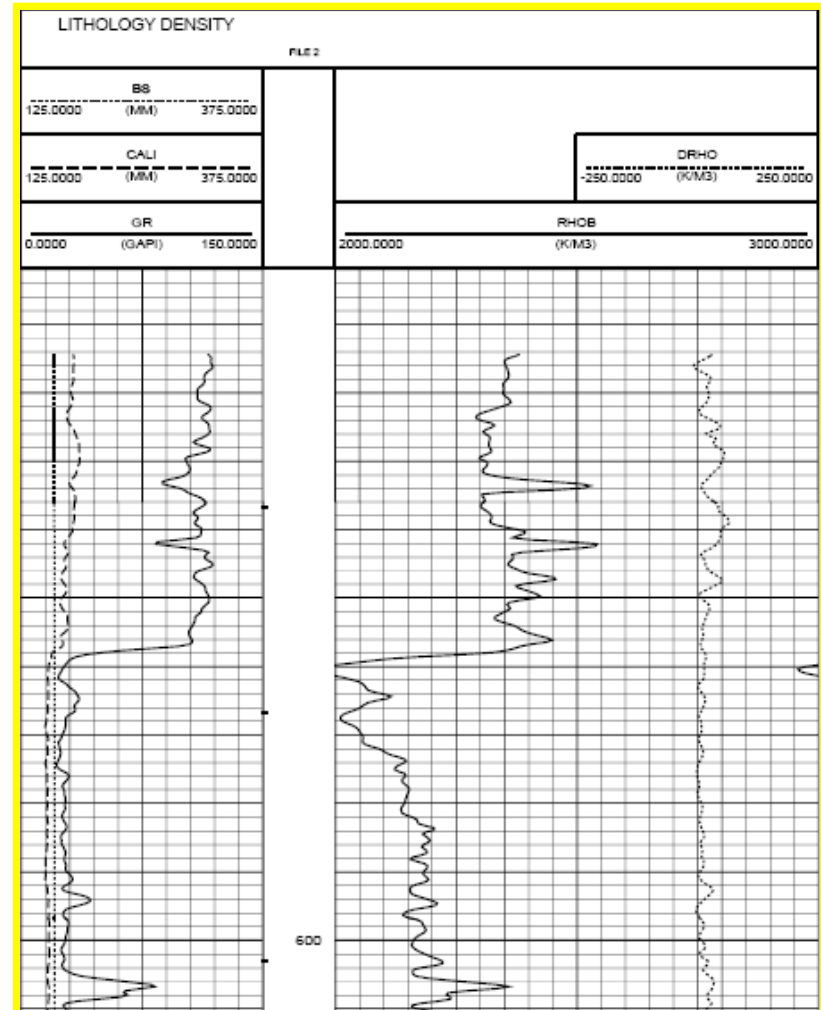

Density log

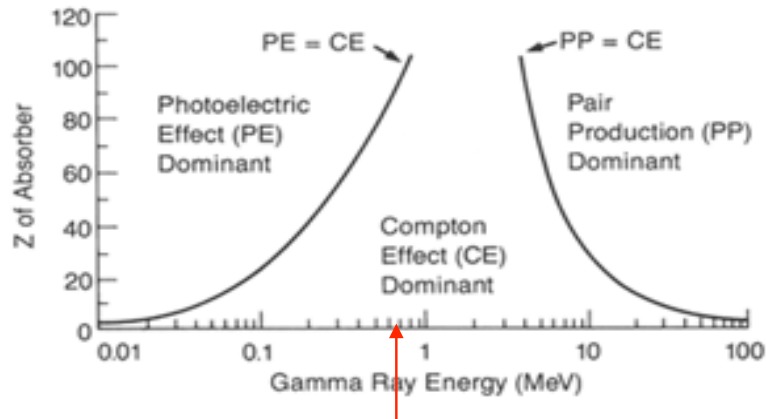

Energy of the density log source (662 KeV)

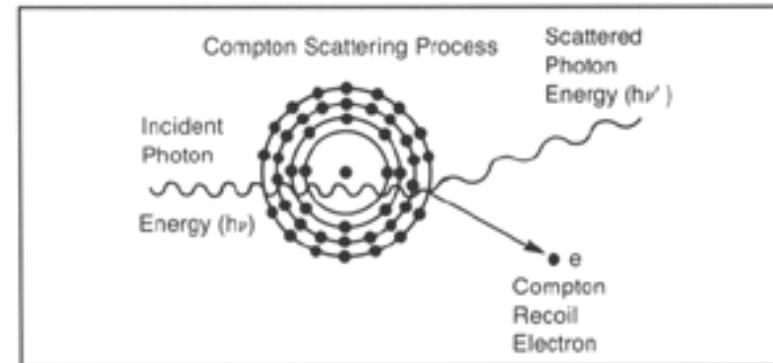

Compton scattering process

Predominant interaction for the ρ_b measurement

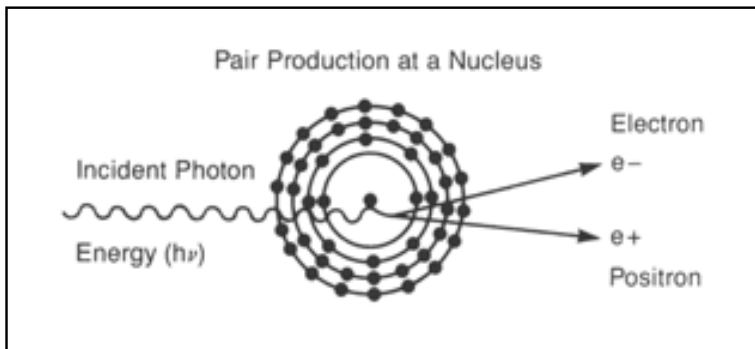

Pair production at a nucleus

This interaction does not occur due to the lower energy of GRs emitted by the Density log source

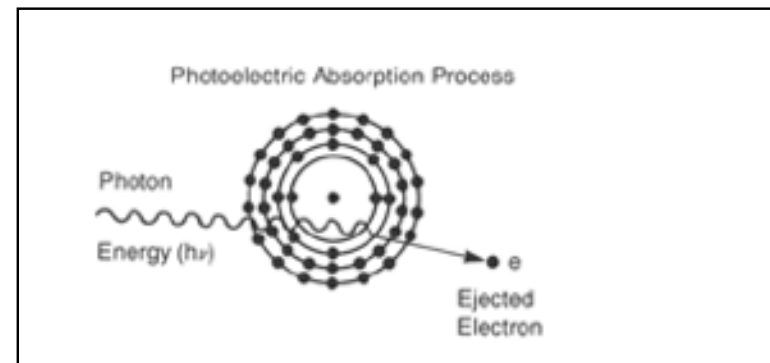

Photoelectric absorption process

Predominant interaction for the measurement of P_{ef}

Density log

Gamma rays produced by a radioactive source interact with the subsurface formations.

The Gamma rays generated by a Cs 137 source, because of their energy (662 KeV), may only interact with the electrons orbiting around atomic nuclei.

Heavier is the formation higher is its electronic density and lesser is the count rate of gamma rays detected by the Sodium Iodide (NaI) scintillation detectors placed at a fixed distance from the source.

This is due to both the Compton interaction for higher energy gamma rays and by the Photoelectric Absorption effect for lower energy gamma rays.

The Count Rate of gamma rays at a high energy window is used for the measurement of the bulk density (r_b) and the Count Rate of the gamma rays at a low energy window is used for the measurement of the P_{ef} .

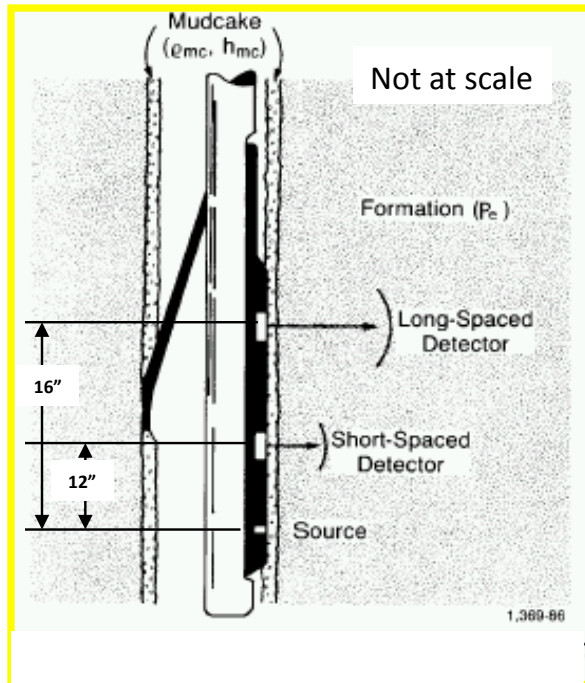

DOI @ 5"
VR @ 1 ft

ρ_b = bulk density
 ρ_e = electronic density
 Z = Atomic number
 A = Atomic weight
 $\rho_e = \rho_b (2Z/A)$
 for a monoatomic substance
 $\rho_b = 1,0704 \rho_e - 0,1883$
 for a large number of substances

Density log

Z/A Ratios of Common Earth Elements			
Element	Abundance (ppm)	Atomic Weight	Z/A
Hydrogen	1,400	1.0079	0.9922
Carbon	200	12.0010	0.4995
Nitrogen	20	14.0067	0.4998
Oxygen	466,000	16.0000	0.5000
Sodium	28,300	23.00	0.4785
Magnesium	20,900	24.305	0.4937
Aluminium	81,300	26.98	0.4818
Silicon	339,600	28.086	0.4985
Sulphur	260	32.06	0.4991
Chlorine	130	35.453	0.4795
Potassium	25,900	39.098	0.4859
Calcium	36,300	40.08	0.4990
Titanium	4,400	47.9	0.4593
Manganese	950	54.938	0.4551
Iron	50,0000	55.847	0.4656
Barium	425	137.33	0.4078
Lead	13	207.2	0.3958

Charge-to-Mass Ratios, Mass Densities, Log Response Densities, Photoelectric Absorption Index Values for Materials Commonly Found in Boreholes					
Material	Chemical Formula	$\Sigma Z/\Sigma M$ (charge/amu)	ρ (g cm ⁻³)	ρ_b (g cm ⁻³)	P_e (b/e)
Quartz	SiO ₂	0.499	2.65	2.64	1.806
Calcite	CaCO ₃	0.500	2.71	2.71	5.084
Dolomite	CaMg(CO ₃) ₂	0.499	2.87	2.87	3.142
Montmorillonite (Smectite)	(Na,Ca) _{0.33} (Al,Mg) ₂ Si ₄ O ₁₀ (OH) ₂ nH ₂ O	0.502	2.06	2.02	2.04
Illite	KAl ₃ (Si,Al) ₃ O ₂₀ (OH) ₄ (O,OH) ₁₀	0.499	2.64	2.63	3.45
Kaolinite	Al ₂ O ₃ ·2SiO ₂ ·2H ₂ O	0.504	2.59	2.61	1.83
Chlorite	Mg ₂ (Al,Fe)(OH) ₆ (Al,Si) ₄ O ₁₀	0.497	2.88	2.88	6.30
K-Feldspar	KAlSi ₃ O ₈	0.496	2.56	2.53	2.86
Plagioclase (Na)	NaAlSi ₃ O ₈	0.496	2.62	2.59	1.68
Plagioclase (Ca)	CaAl ₂ Si ₂ O ₈	0.496	2.76	2.74	3.13
Barite	BaSO ₄	0.446	4.48	4.09	266.8
Siderite	FeCO ₃	0.483	3.94	3.89	14.69
Pyrite	FeS ₂	0.483	5.01	4.99	16.97
Hematite	FeS ₂ O ₃	0.476	5.27	5.18	1.48
Anhydrite	CaSO ₄	0.499	2.96	2.97	5.05
Gypsum	CaSO ₄ ·2H ₂ O	0.511	2.31	2.34	3.420
Halite	NaCl	0.479	2.165	2.03	4.65
Sylvite	KCl	0.483	1.99	1.87	8.510
Aluminum	Al	0.482	2.702	2.60	2.5715
Sulfur	S	0.499	2.067	2.02	5.4304
Coal:					
Anthracite	C ₇₂₀ H ₂₃₈ N ₆ O ₁₆	0.513	1.60	1.57	0.161
Bituminous	C ₅₃₂ H ₄₁₈ N ₈ O ₄₁	0.527	1.35	1.33	0.180
Lignite	C ₄₈₀ H ₄₁₂ N ₇ O ₁₀₁	0.500	1.10	0.99	
Oil (medium gravity)	n(CH ₂)	0.570	0.80	0.79	0.125
Gas (160°F, 5,000 psia)	C _n H _{2n+2} (n=1-6)	0.619	0.20	0.08	0.119
Formation water:					
	H ₂ O (fresh)	0.555	1.00	1.00	0.358
	120,000 ppm NaCl	0.546	1.086	1.081	0.807

Density log: the calibration process

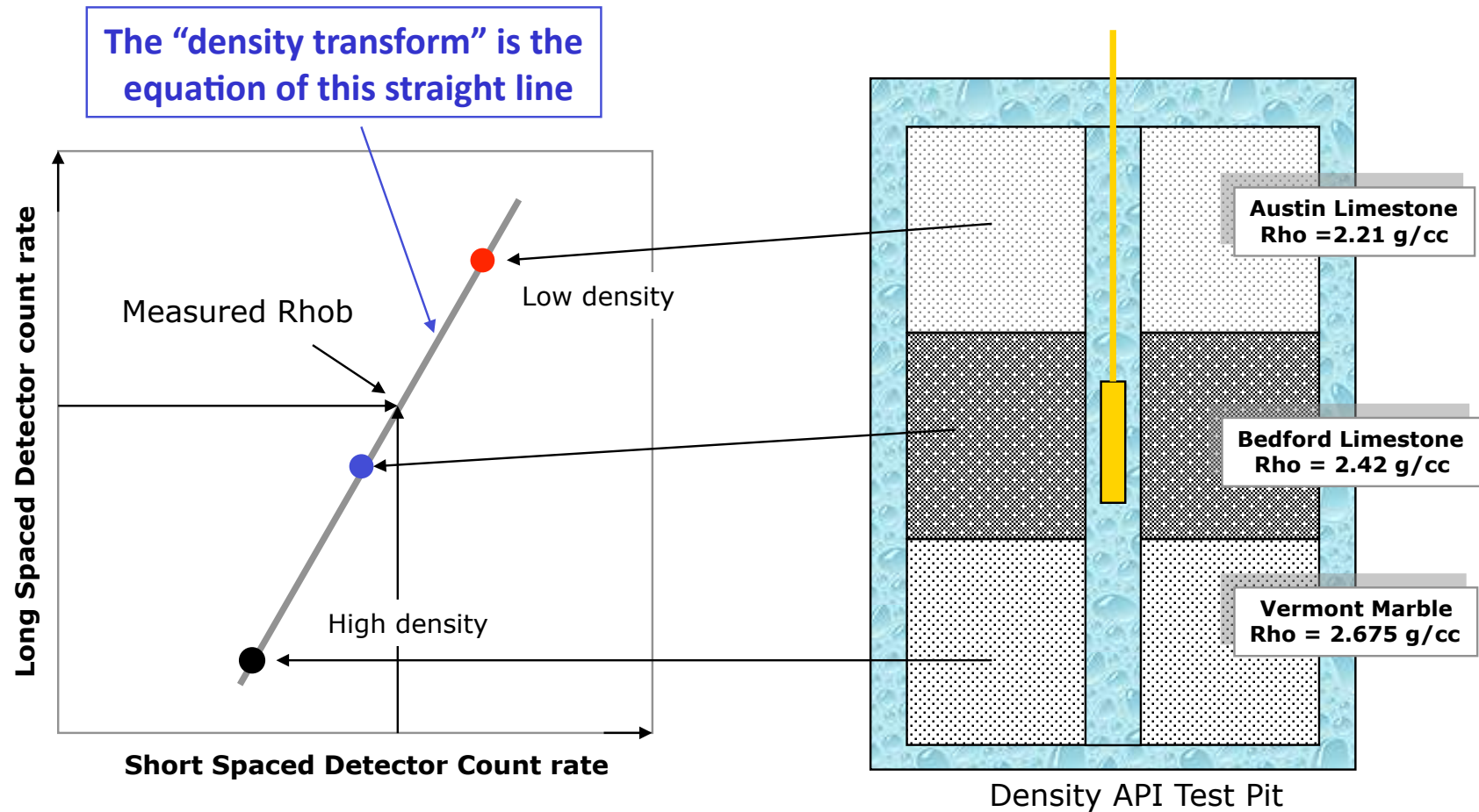

“Density transform” and DRHO

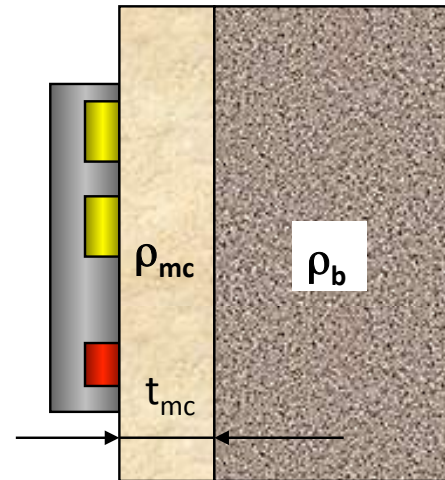
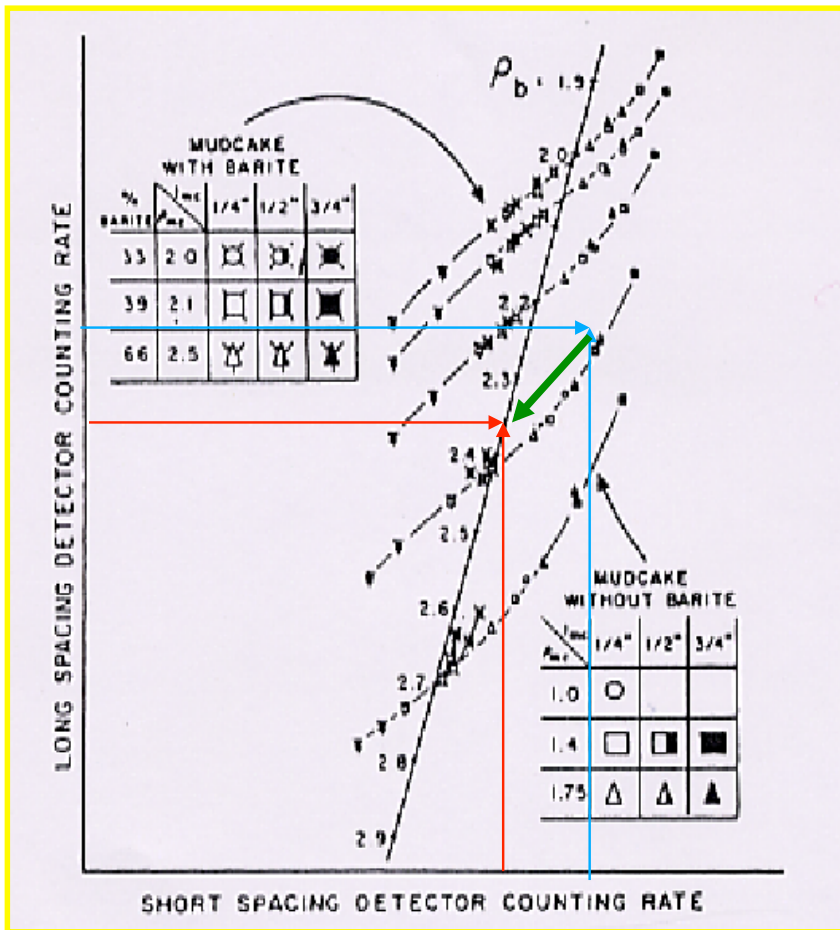

DRHO Correction is a function of:
 $\rho_{mc} - \rho_b$ contrast & t_{mc}

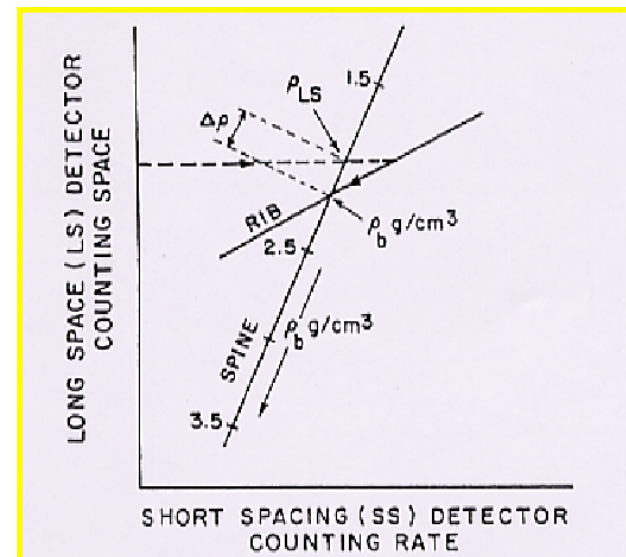

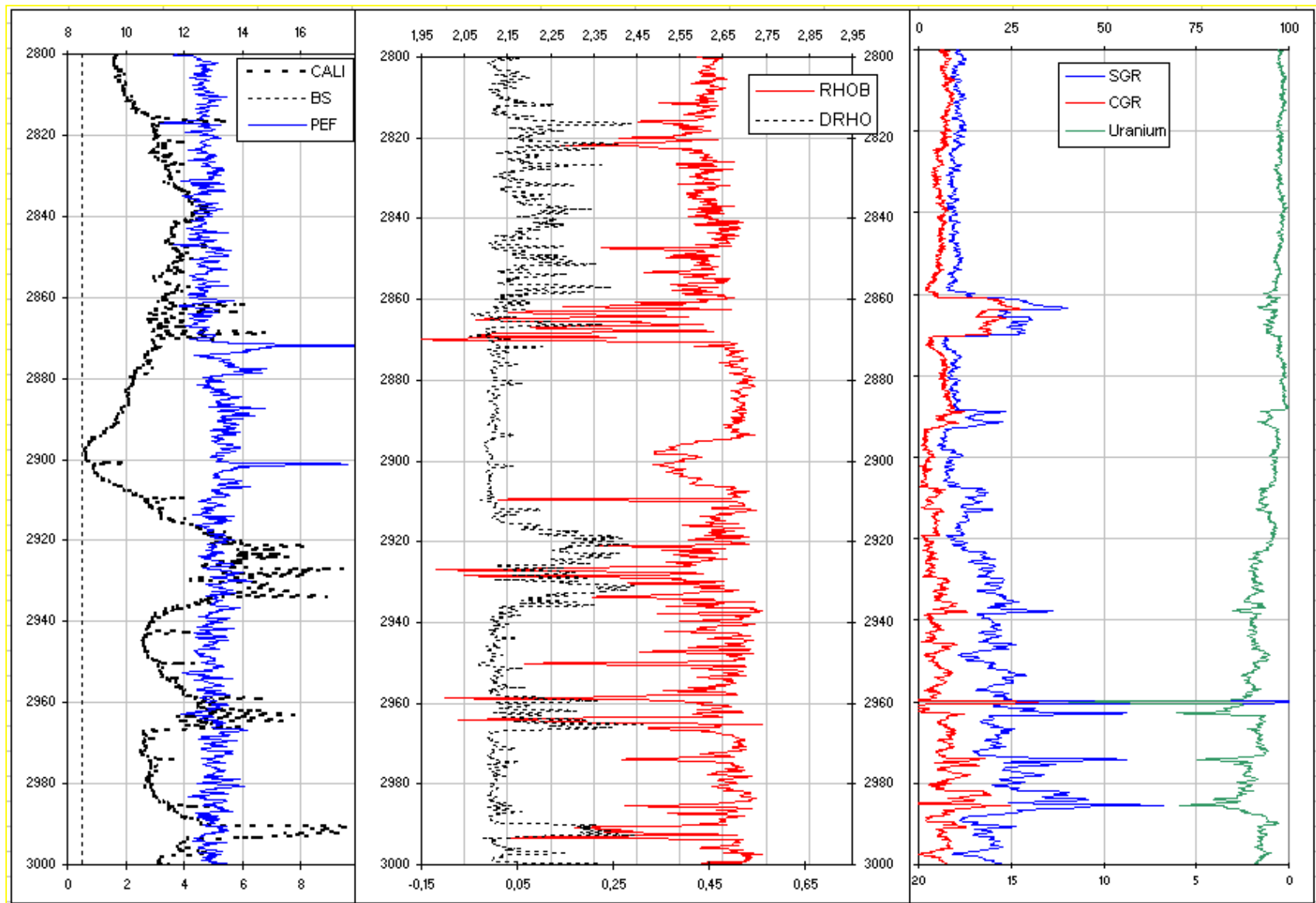

Density log porosity

Matrix	Fluid
ρ_{ma}	ρ_f
$(1 - \phi)$	ϕ

ρ_b

$$\rho_b = \phi \rho_f + (1 - \phi) \rho_{ma} \text{ (clean wet zone)}$$

where:

ρ_b is the measured bulk density (from Litho-Density tool)

ρ_{ma} is the density of the matrix

ρ_f is the density of the fluid

ϕ is the percent volume of pore space

$(1 - \phi)$ is the percent volume of matrix.

This can be written as

$$\phi_D = \frac{\rho_{ma} - \rho_b}{\rho_{ma} - \rho_f}$$

where:

ρ_{ma} depends on lithology

ρ_b is measured by the density log

ρ_f depends on fluid type in pore volumes.

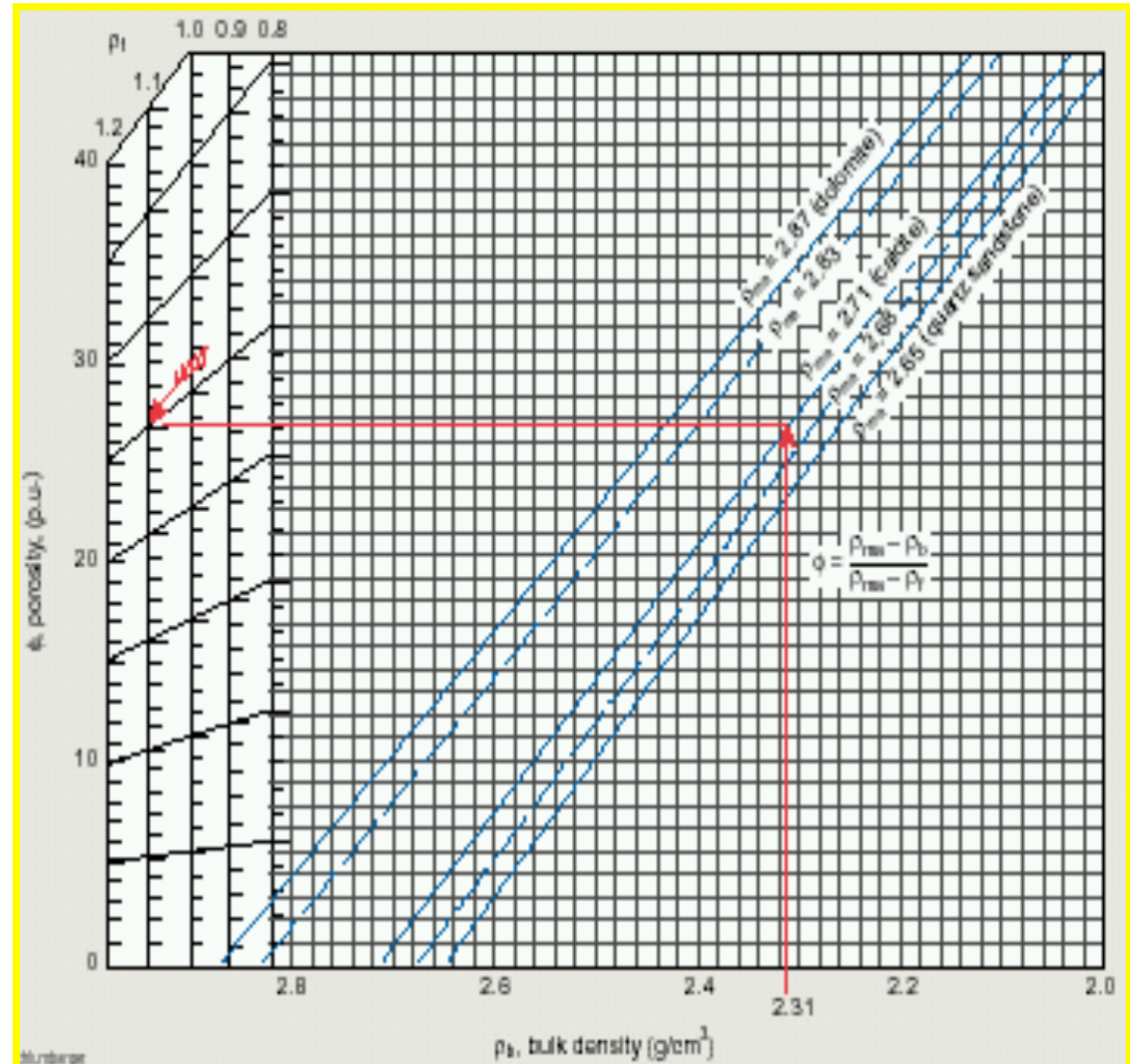

Densities of minerals and reservoir fluids

Charge-to-Mass Ratios, Mass Densities, Log Response Densities, Photoelectric Absorption Index Values for Materials Commonly Found in Boreholes					
Material	Chemical Formula	ΣZ^2EM (charge/amu)	ρ (g cm ⁻³)	ρ_b (g cm ⁻³)	P_e (b/e)
Quartz	SiO ₂	0.499	2.65	2.64	1.806
Calcite	CaCO ₃	0.500	2.71	2.71	5.084
Dolomite	CaMg(CO ₃) ₂	0.499	2.87	2.87	3.142
Montmorillonite (Smectite)	(Na,Ca) _{0.33} (Al,Mg) ₂ Si ₄ O ₁₀ (OH) ₂ nH ₂ O	0.502	2.06	2.02	2.04
Illite	KAl ₄ (Si,Al) ₈ O ₂₀ (OH) ₄ (O,OH) ₁₀	0.499	2.64	2.63	3.45
Kaolinite	Al ₂ O ₃ ·2SiO ₂ ·2H ₂ O	0.504	2.59	2.61	1.83
Chlorite	Mg ₃ (Al,Fe)(OH) ₆ (Al,Si) ₄ O ₁₀	0.497	2.88	2.88	6.30
K-Feldspar	KAlSi ₃ O ₈	0.496	2.56	2.53	2.86
Plagioclase (Na)	NaAlSi ₃ O ₈	0.496	2.62	2.59	1.68
Plagioclase (Ca)	CaAl ₂ Si ₂ O ₈	0.496	2.76	2.74	3.13
Barite	BaSO ₄	0.446	4.48	4.09	266.8
Siderite	FeCO ₃	0.483	3.94	3.89	14.69
Pyrite	FeS ₂	0.483	5.01	4.99	16.97
Hematite	Fe ₂ O ₃	0.476	5.27	5.18	1.48
Anhydrite	CaSO ₄	0.499	2.96	2.97	5.05
Gypsum	CaSO ₄ ·2H ₂ O	0.511	2.31	2.34	3.420
Halite	NaCl	0.479	2.165	2.03	4.65
Sylvite	KCl	0.483	1.99	1.87	8.510
Aluminum	Al	0.482	2.702	2.60	2.5715
Sulfur	S	0.499	2.067	2.02	5.4304
Coal:					
Anthracite	C ₇₂₀ H ₂₃₈ N ₆ O ₁₆	0.513	1.60	1.57	0.161
Bituminous	C ₅₃₂ H ₄₄₈ N ₈ O ₄₁	0.527	1.35	1.33	0.180
Lignite	C ₄₈₀ H ₄₁₂ N ₇ O ₁₀₁	0.500	1.10	0.99	
Oil (medium gravity)	n(CH ₂)	0.570	0.80	0.79	0.125
Gas (160°F., 5,000 psia)	C _n H _{2n+2} (n=1-6)	0.619	0.20	0.08	0.119
Formation water:					
	H ₂ O (fresh)	0.555	1.00	1.00	0.358
	120,000 ppm NaCl	0.546	1.086	1.081	0.807

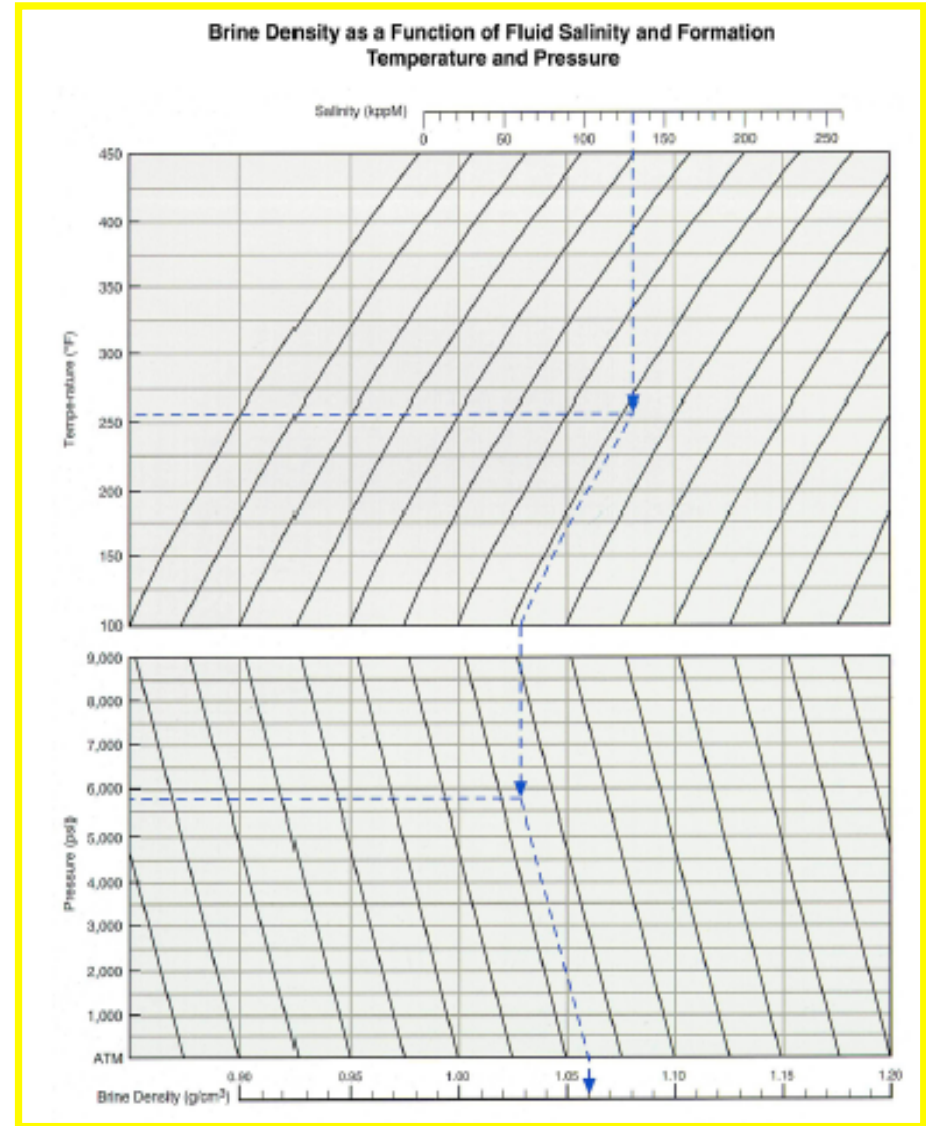

Basic Density log equations

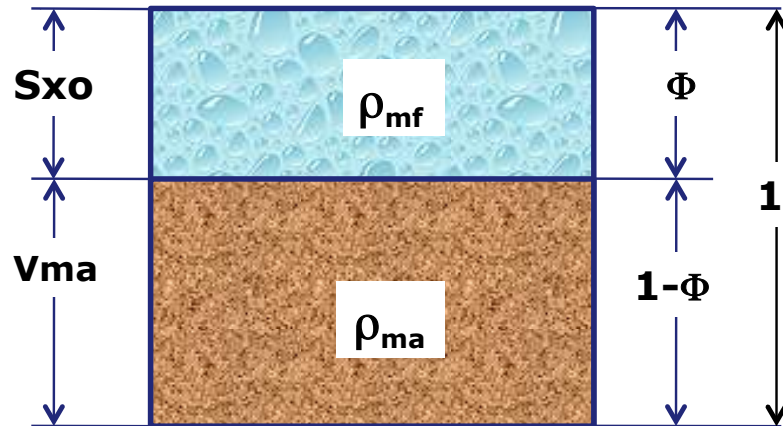

$S_w = 100\%$ and $S_w = S_{xo}$

$$\rho_b = (1 - \Phi) \rho_{ma} + \Phi \rho_{mf}$$

Mineral	Formula	ρ_{ma} (g/cc)	Pef (b/e)
Quartz	SiO_2	2.65	1.80
Calcite	$CaCO_3$	2.71	5.08
Dolomite	$MgCa(CO_3)_2$	2.87	3.50
Anhydrite	$CaSO_4$	2.97	5.05
Halite	$NaCl$	2.15	4.65
Oil (average Gravity)	$n(CH_2)$	0.80	0.125
Gas (Reservoir conditions)	C_nH_{2n+2}	0.20	0.120
Water (fresh)	H_2O	1.00	0.36
Water (salty)	H_2O	1.08	0.80

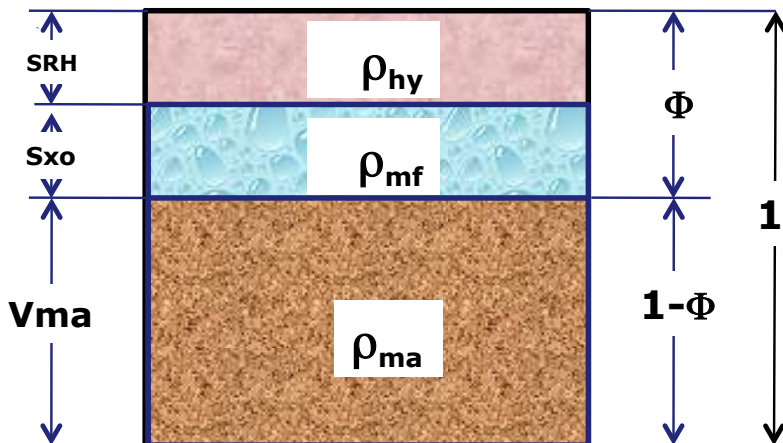

$S_w < 100\%$ and $SRH = 1 - S_{xo}$

$$\rho_b = (1 - \Phi) \rho_{ma} + S_{xo} \Phi \rho_{mf} + [(1 - S_{xo}) \Phi] \rho_{hy}$$

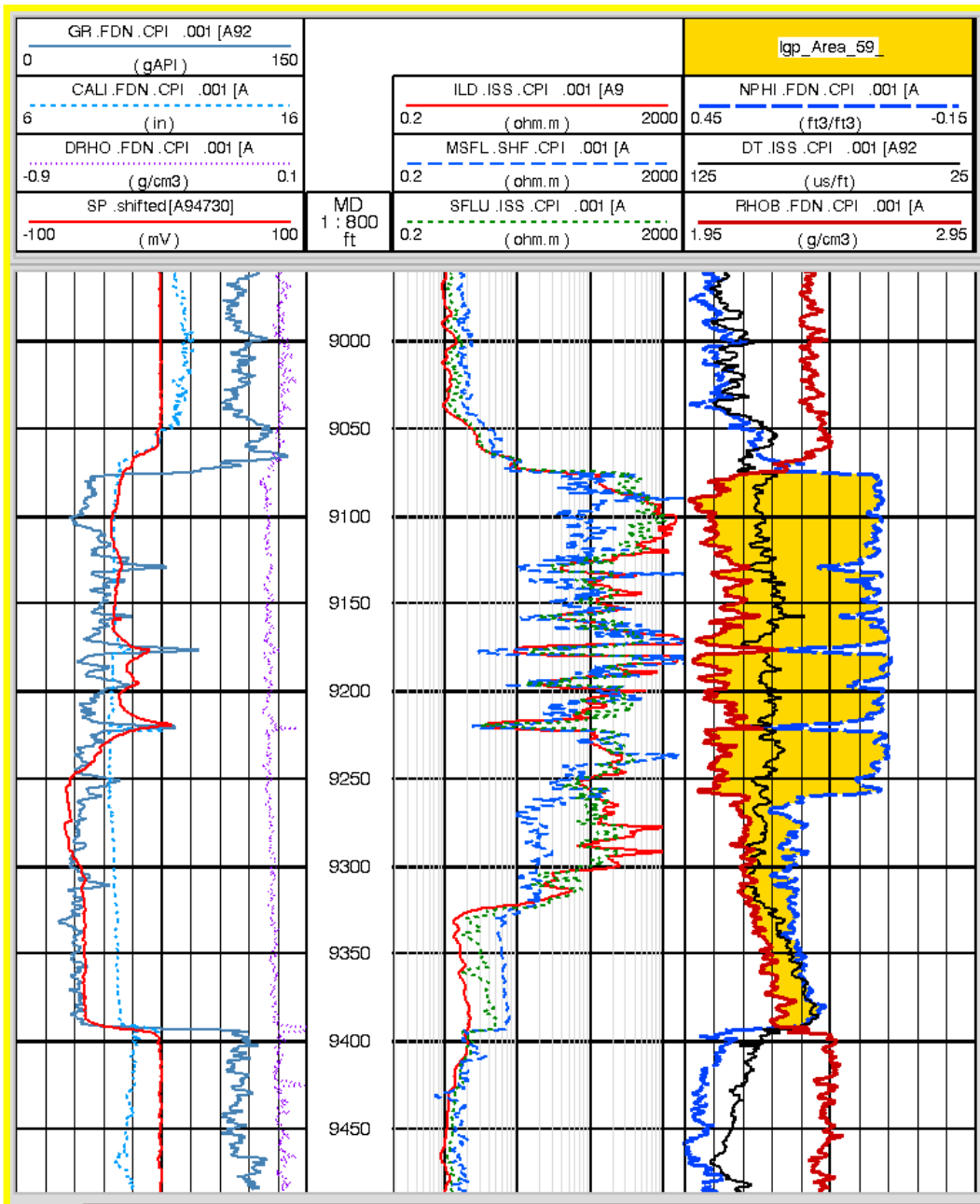

Density log: the gas effect

When the reservoir is partially gas saturated, the Formation Density is lower with respect to the one we can measure when the same rock is totally oil or water saturated.

This effect is known as “GAS EFFECT ON DENSITY LOG”.

In front of Gas Bearing levels, the RHOB curve needs to be corrected for this “GAS EFFECT”.

Neutron log

The neutron log is mostly influenced by the hydrogen content of the formation.

In “clean” water or oil saturated formations, the neutron log measures an “apparent” total porosity of the rock.

When the log is acquired in “limestone matrix” (i.e. $\rho_{ma} = 2,71$ g/cc), the neutron log measures directly the total porosity of the formation.

If the lithology of the matrix is different from “limestone” (calcite), the so called lithology correction is required.

Other neutron log applications are:

- formation fluid analysis,
- lithology analysis.

Neutron log (CNL)

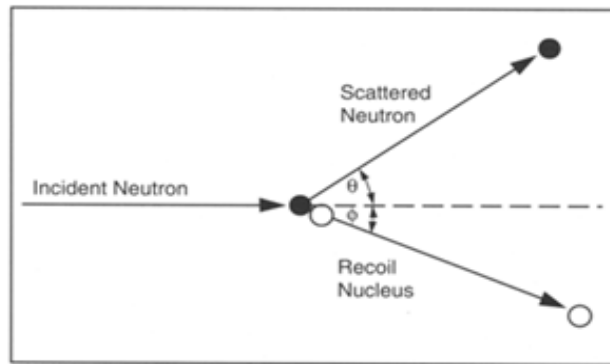

Schematic diagram of a neutron-nucleus collision. θ is the "scattering angle," and ϕ is the "recoil angle." The energy loss of the neutron on collision equals the recoil energy of the nucleus.

Neutron Energy Losses

Element	Average Number Collisions	Maximum Energy Loss/ Collision	Atomic Weight	Atomic Number
Calcium	371	8%	40.1	20
Chlorine	316	10%	35.5	17
Silicon	261	12%	28.1	14
Oxygen	150	21%	16.0	8
Carbon	115	28%	12.0	6
Hydrogen	18	100%	1.0	1

Hydrogen – Average loss due to angular collision is 63%.

The neutrons produced by the chemical source at the average energy of 4,5 MeV, interact with the nuclei of the elements present in the formation losing some of their energy at each collision.

The highest energy is lost when the neutron hits a Hydrogen atom of a similar mass.

With high formation hydrogen content the loss of energy by the neutrons is fast and less time is necessary to reduce the energy of the neutron to "epithermal" level first (0,6 eV) and to "thermal" energy later (0,025 eV).

When a neutron is "thermalized" it can only be captured by high cross section elements present in the formation such as Chlorine (Cl), Iron (Fe), Boron (Bo) and Gadolinium (Gd).

The excess of energy of these atoms is released by the emission of capture γ rays of specific energy (γ ray Spectrometry).

Neutron log

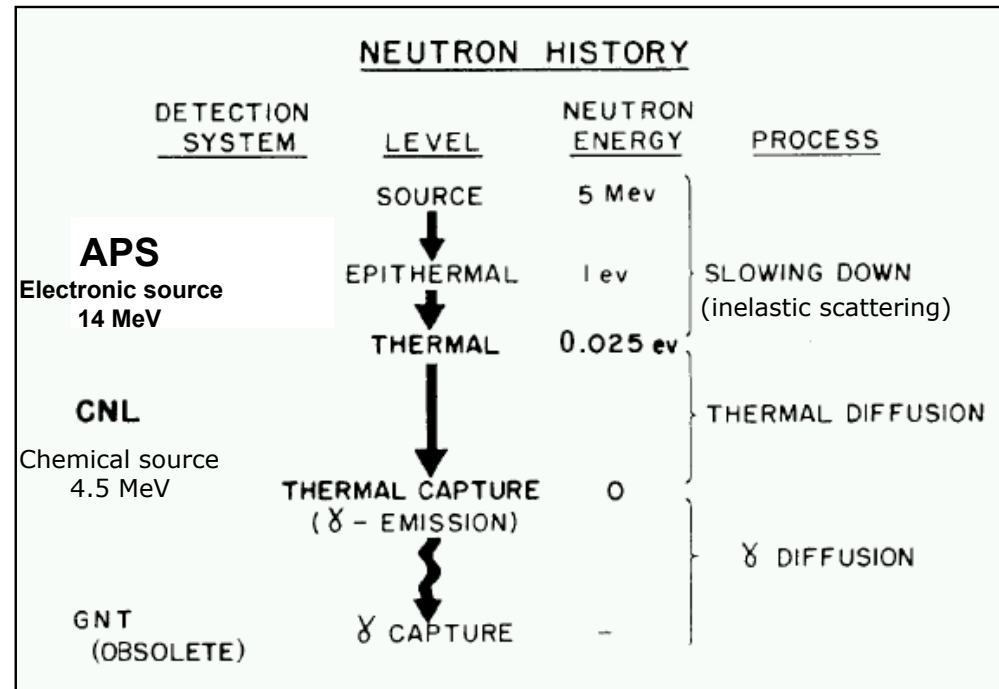
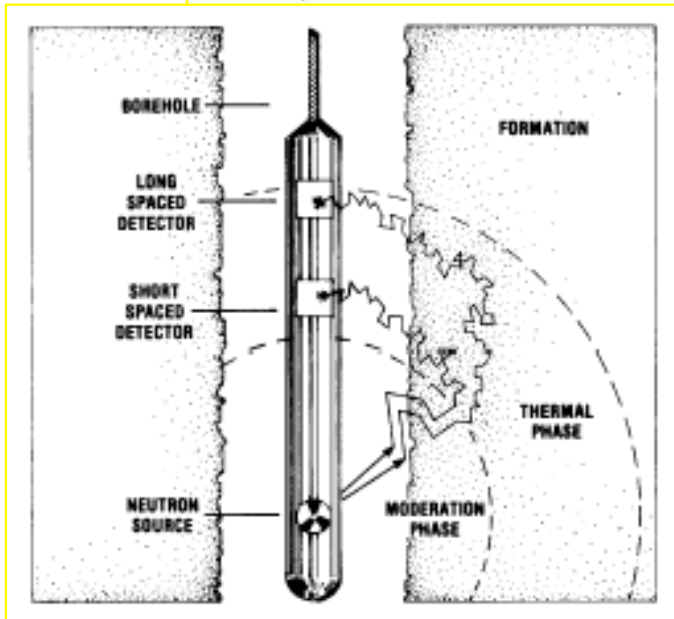
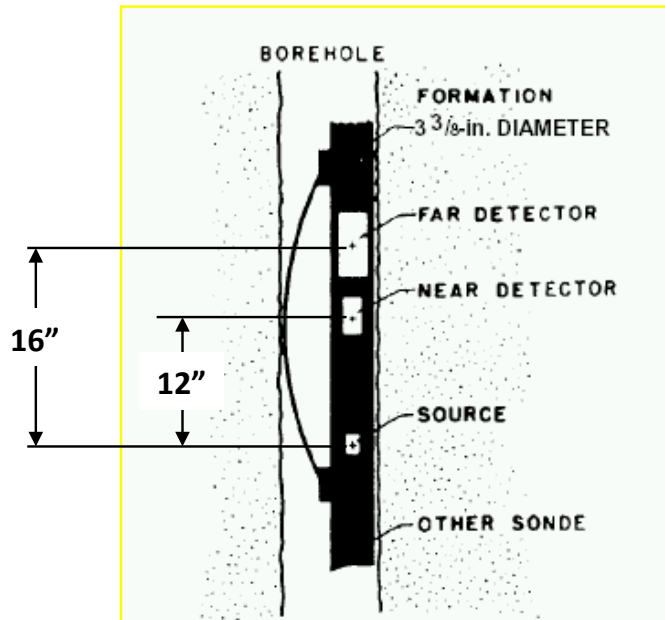

CNL type of tool
DOI @ 8"-12"
VR @ 2 ft

Neutron calibration & “Neutron Porosity Transform”

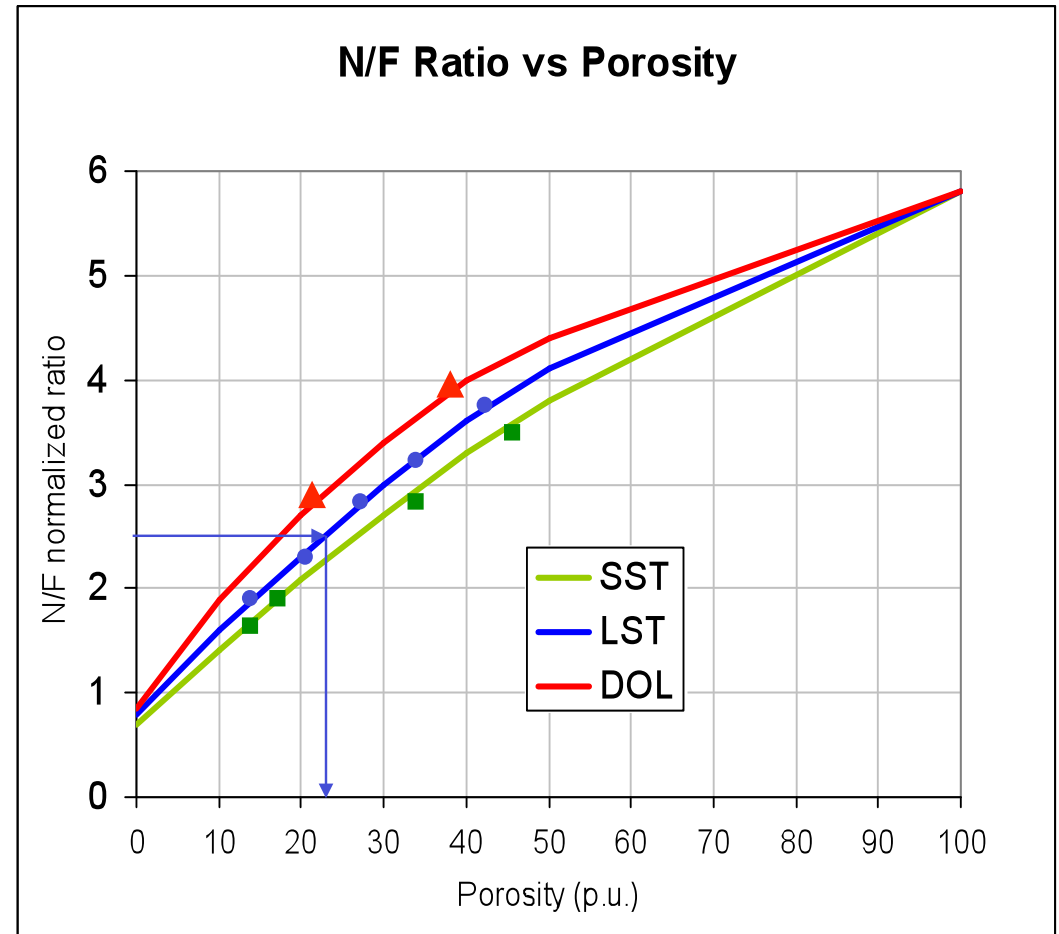
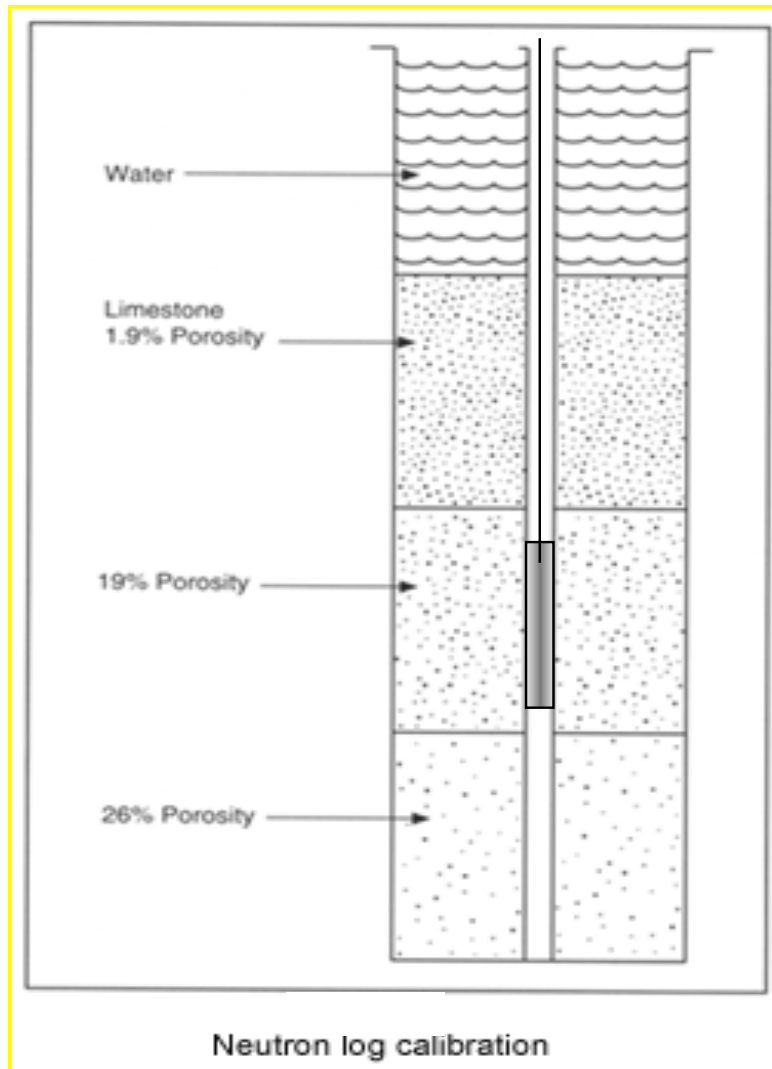

Neutron log

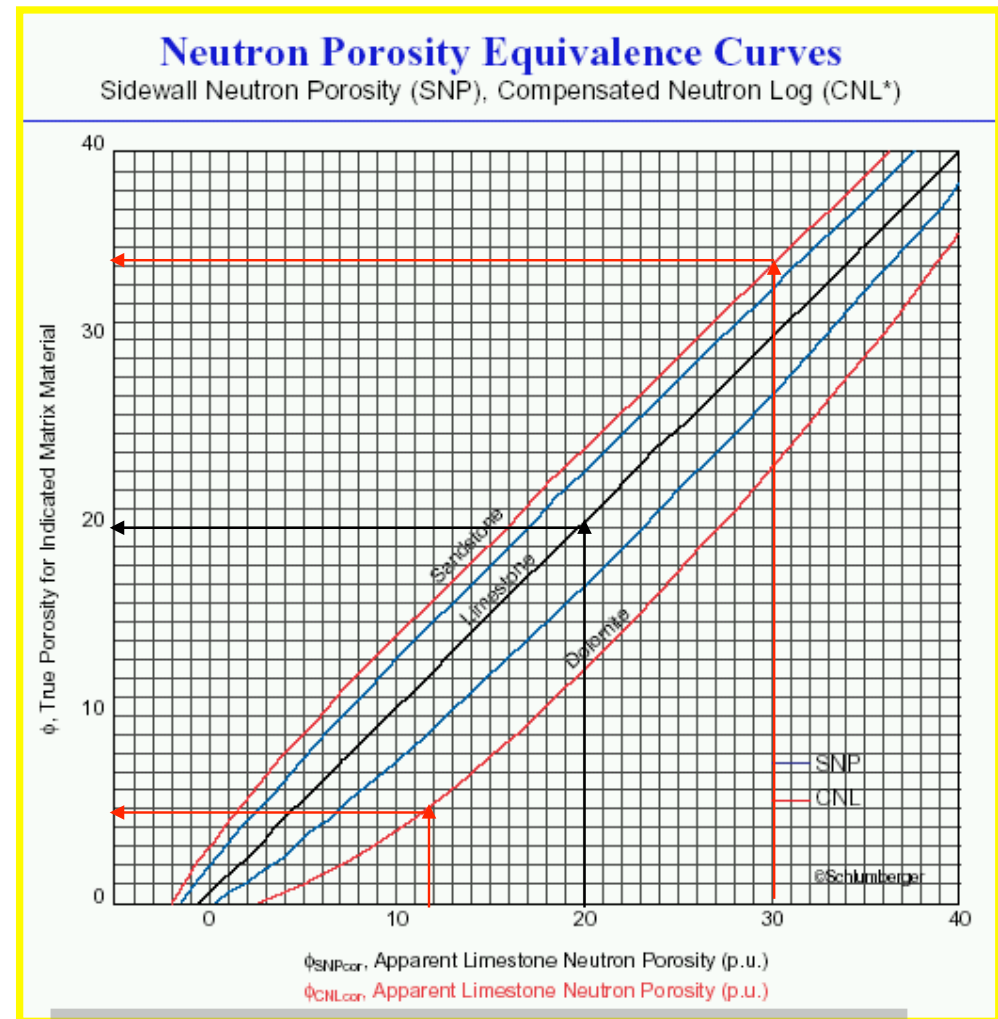
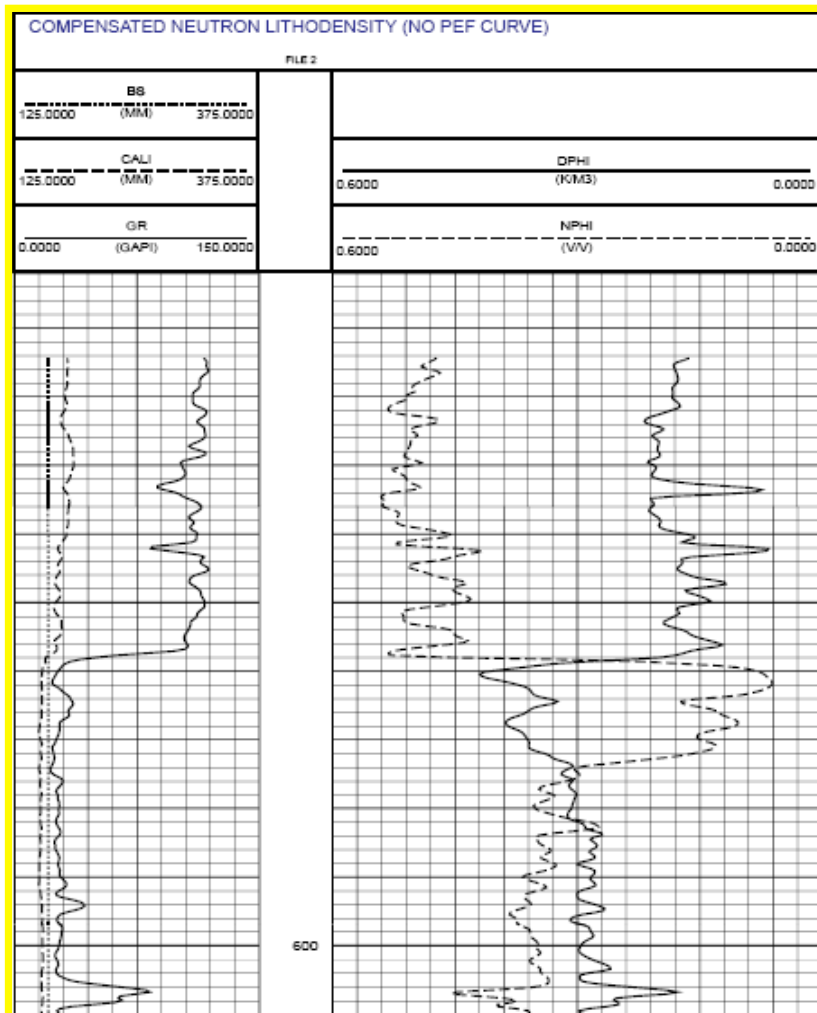

This chart is used for the lithology correction of Neutron readings

Basic Neutron log equations

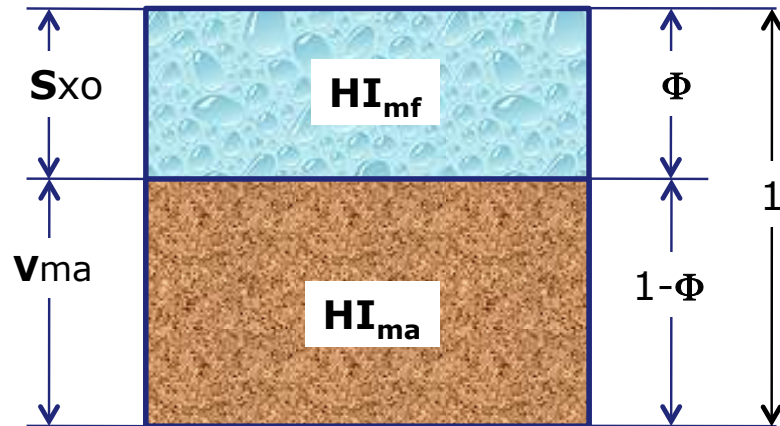

$$S_w = 100 \% \text{ and } S_w = S_{xo}$$

$$HI_{log} = (1 - \Phi) HI_{ma} + \Phi HI_{mf}$$

since HI_{ma} is negligible

$$HI_{log} = \Phi HI_{mf}$$

where $HI_{mf} = 1$

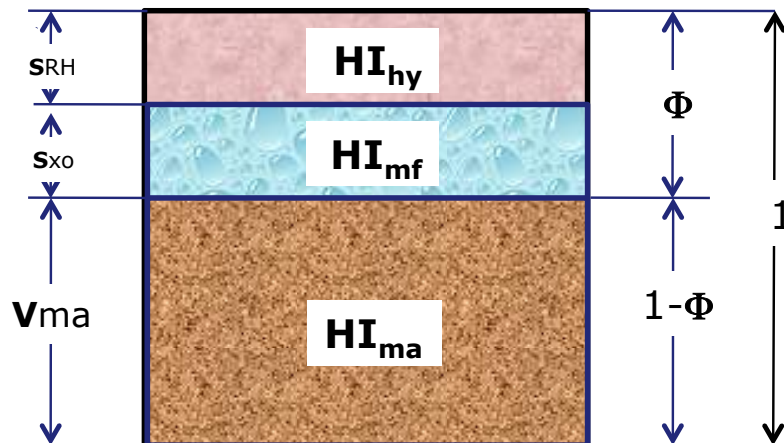

$$S_w < 100 \% \text{ and } SRH = 1 - S_{xo}$$

$$HI_{log} = (1 - \Phi) HI_{ma} + S_{xo} \Phi HI_{mf} + [(1 - S_{xo}) \Phi] HI_{hy}$$

Neutron log Gas effect

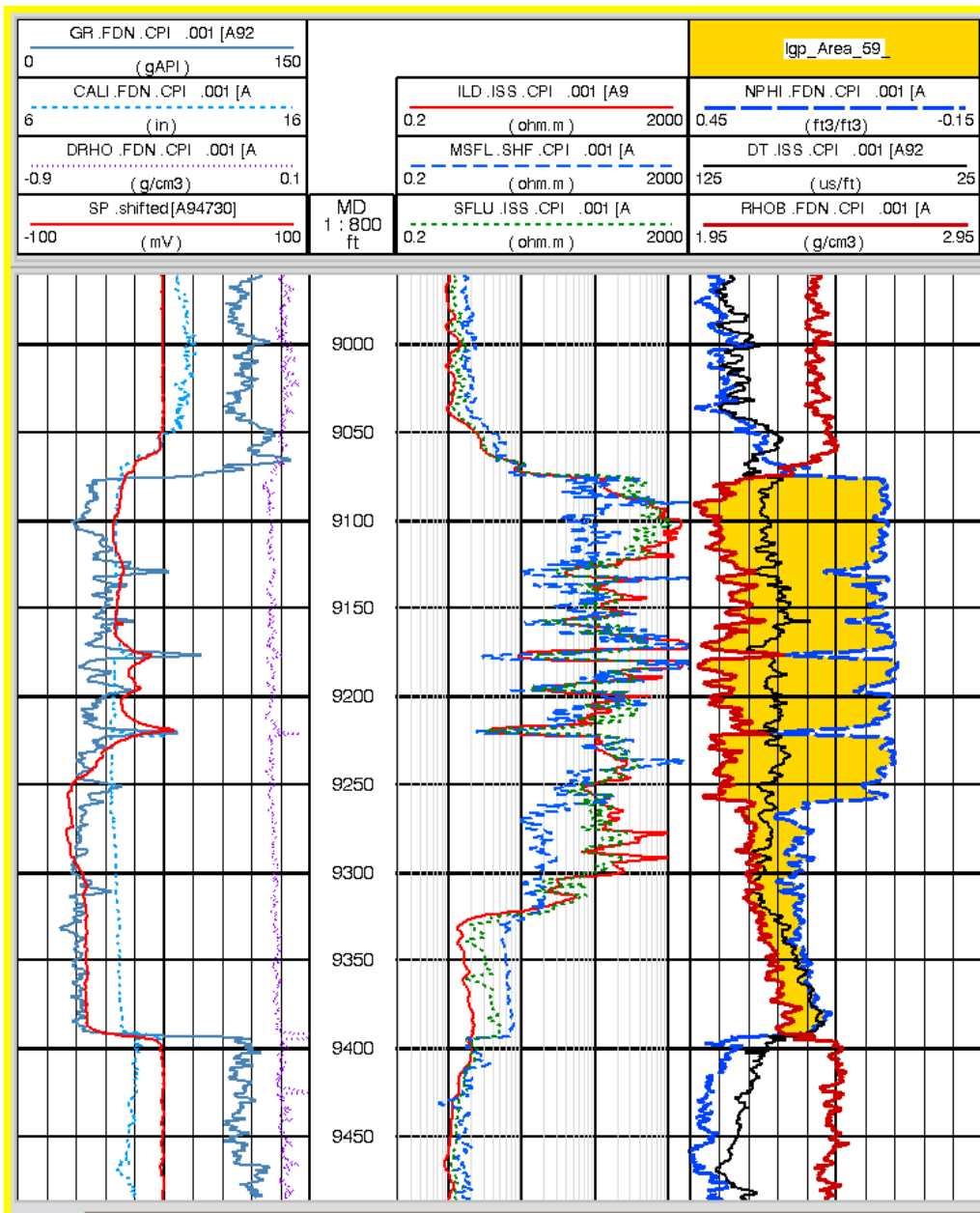

When the porosity is partially saturated by low density hydrocarbon, neutron readings are lower with respect to the ones in a water or water and oil saturated formation.

This is the so called gas effect.

In gas bearing zones, a “light hydrocarbon correction” is necessary before a quantitative use of the neutron curve.

Density/Neutron scales

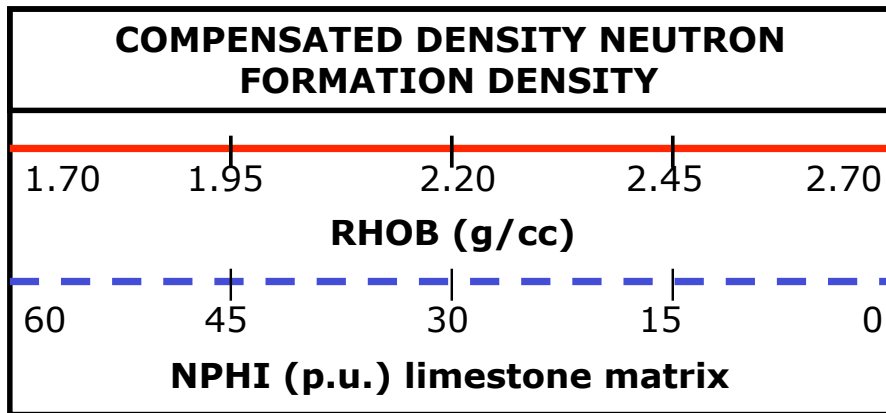
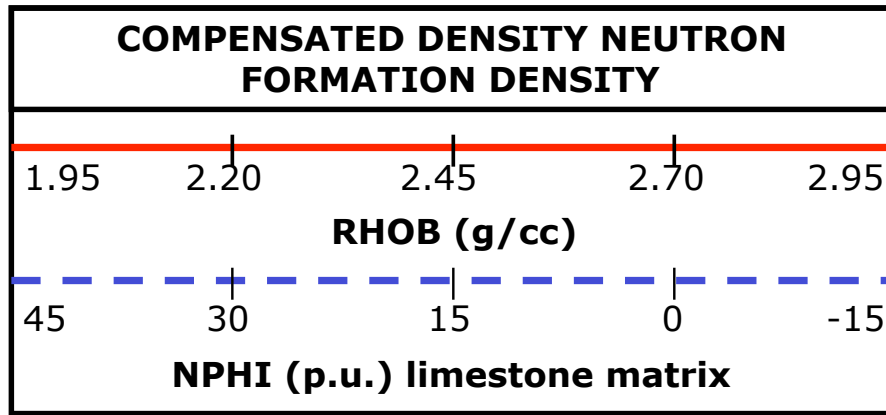

These are the so called “compatible” scales for the presentation of Density Neutron logs based on a “limestone” matrix, i.e. when $NPHI = 0$, $RHOB$ is 2,70 g/cc).

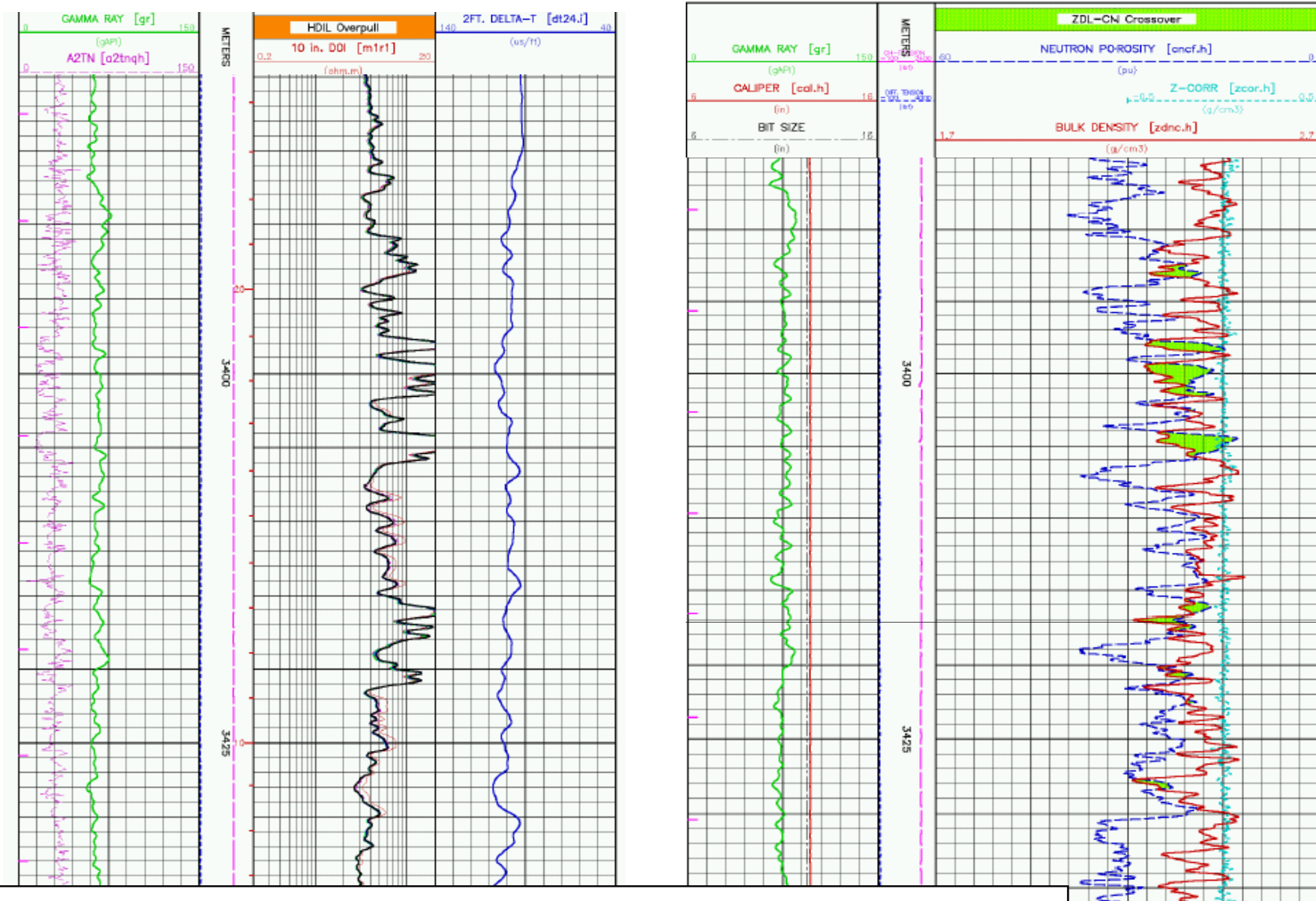

An example from a North Adriatic Sea sand/shale reservoir

RHOB vs NPHI Crossplot for CNL Schlumberger

Porosity and Lithology Determination from
Formation Density Log and CNL* Compensated Neutron Log
For CNL logs before 1986, or labeled NPHI

CP-10

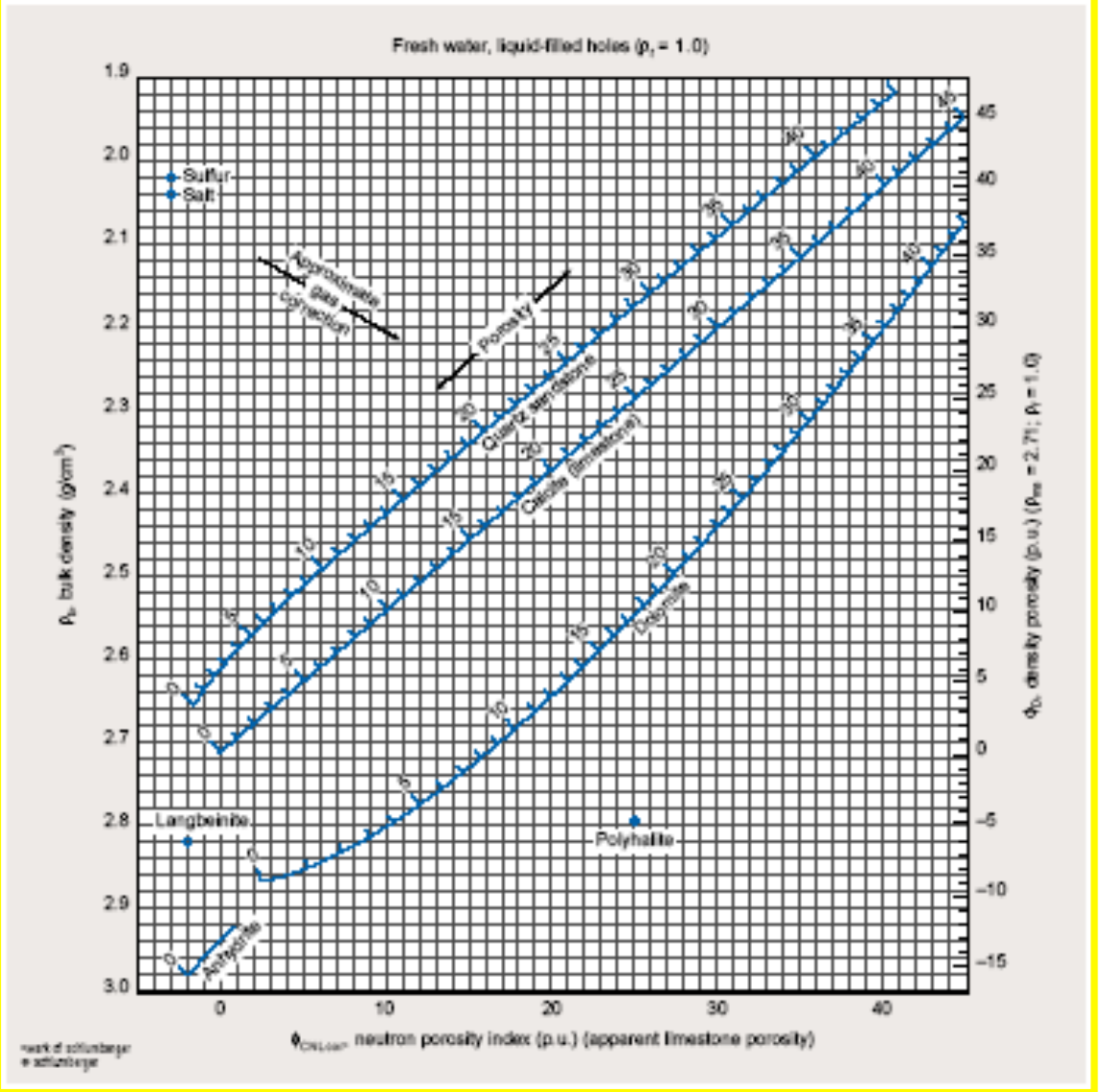

GR .FDN .CPI .001 [A92]				lqp_Area_59	
0	(gAPI)	150			
CALI .FDN .CPI .001 [A				NPFI .FDN .CPI .001 [A	
6	(in)	16		0.45	(ft3/ft3) -0.15
DRHO .FDN .CPI .001 [A				DT .ISS .CPI .001 [A92	
-0.9	(g/cm3)	0.1		125	(us/ft) 25
SP .shifted[A94730]		MD		RHOB .FDN .CPI .001 [A	
-100	(mV)	100	1 : 800	1.95	(g/cm3) 2.95
			ft		
ILD .ISS .CPI .001 [A9		MSFL .SHF .CPI .001 [A		SFLU .ISS .CPI .001 [A	
0.2	(ohm.m)	2000		0.2	(ohm.m) 2000

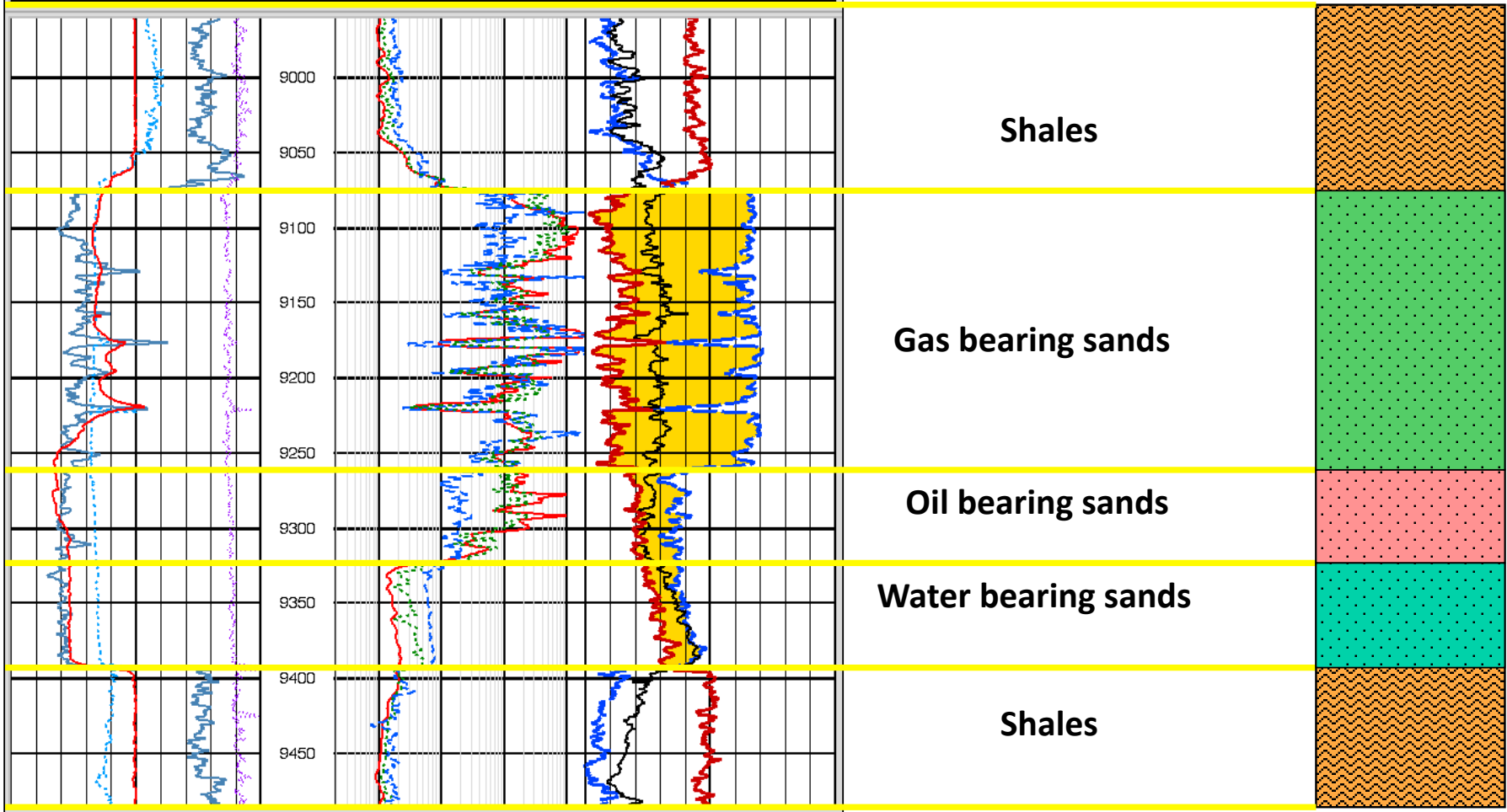

Basics of Geophysical well Logs_Porosity

Complex Sand Xplot Density Neutron (RHOF 1 g/cc)

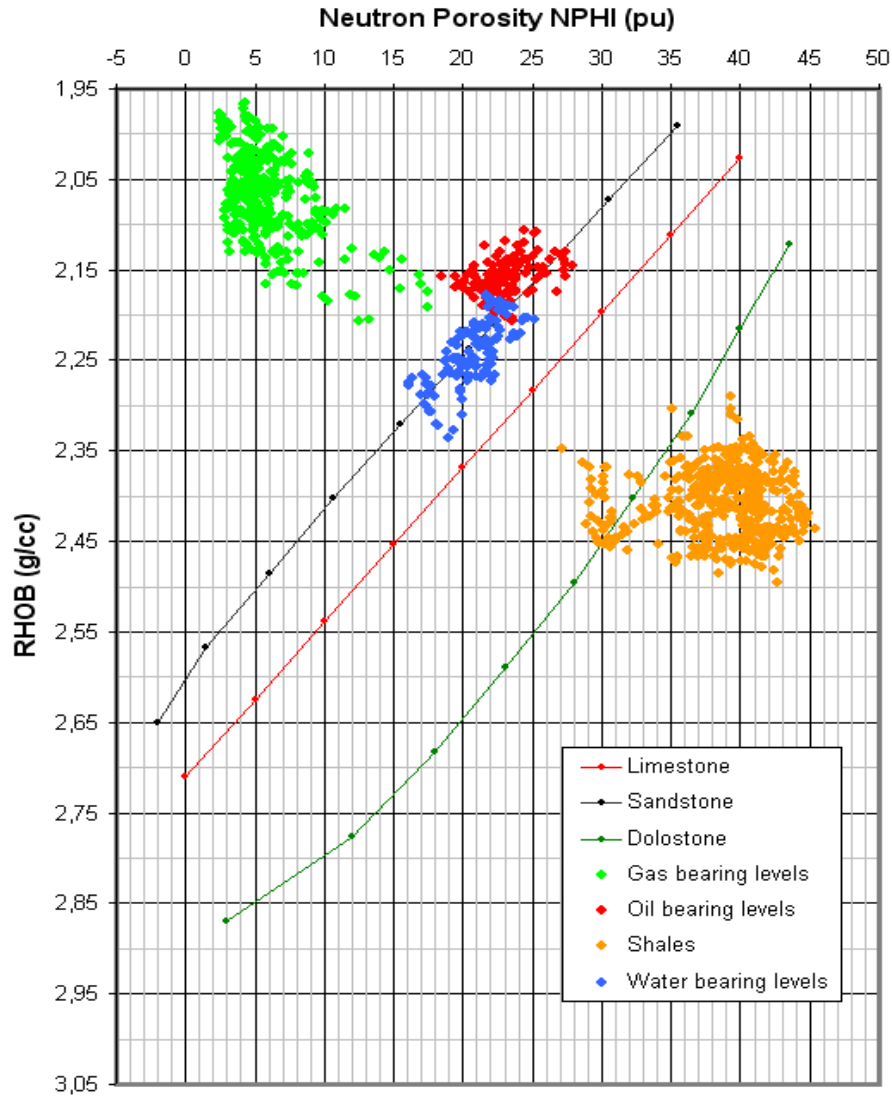

**A typical
Density/Neutron
crossplot**

Acoustic (sonic) logs

Acoustic logs measure the velocity of propagation of acoustic waves in subsurface formations.

This velocity is a function of:

- rock matrix
- porosity distribution

Applications of acoustic logs are:

- porosity evaluation,
- lithology identification.

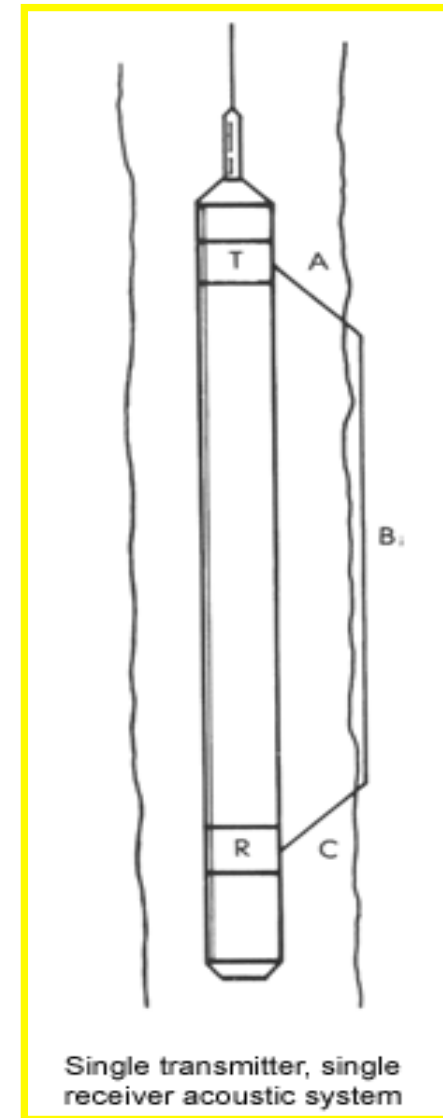

Acoustic waves in a wellbore

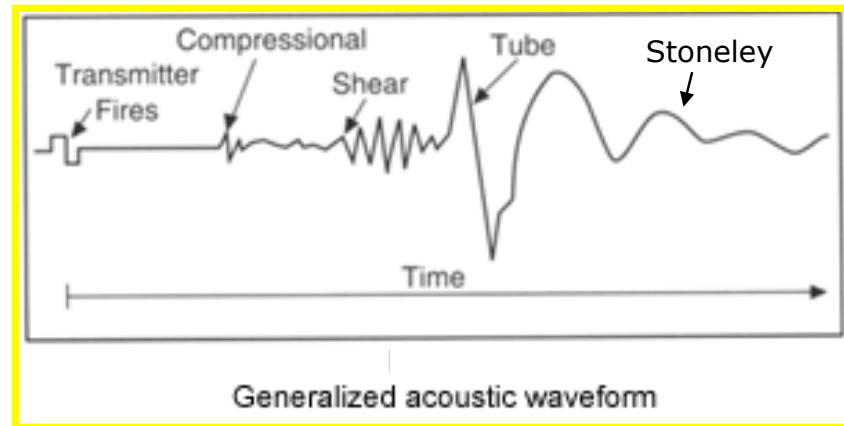
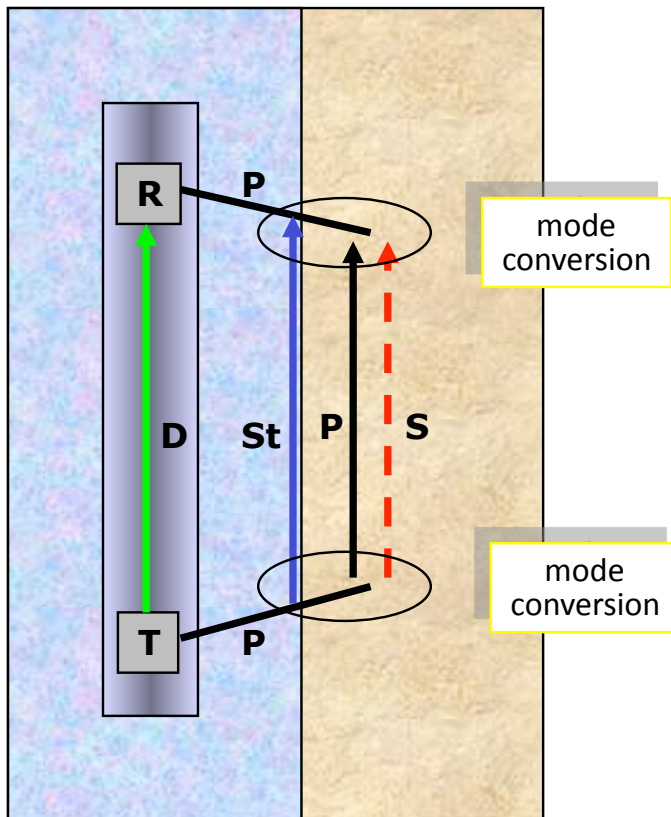

Wave train components

D Direct waves

P Compressional waves

S Shear waves

St Stoneley waves

Standard acoustic tools are based only on compressional wave measurements, while new technology acoustic tools (Array Sonic) measure all the component of the wave train (P, S and Stoneley). Direct waves are strongly attenuated and not detected.

Acoustic logs: conventional BHC tools

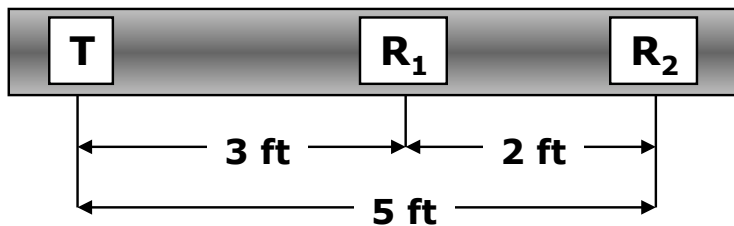
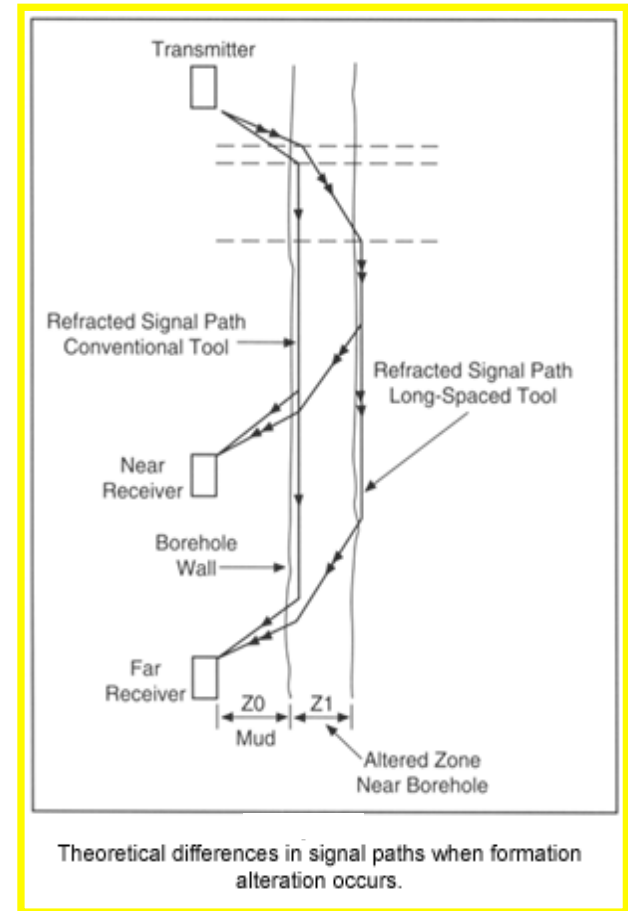
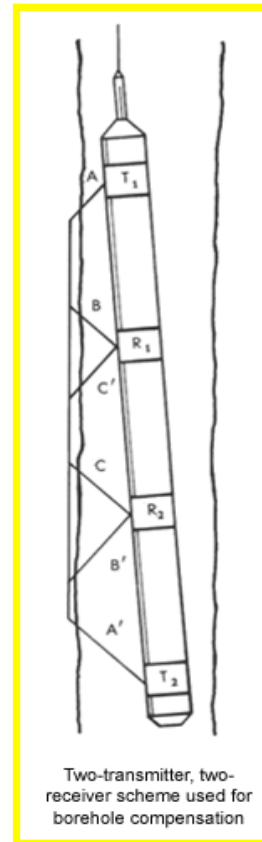
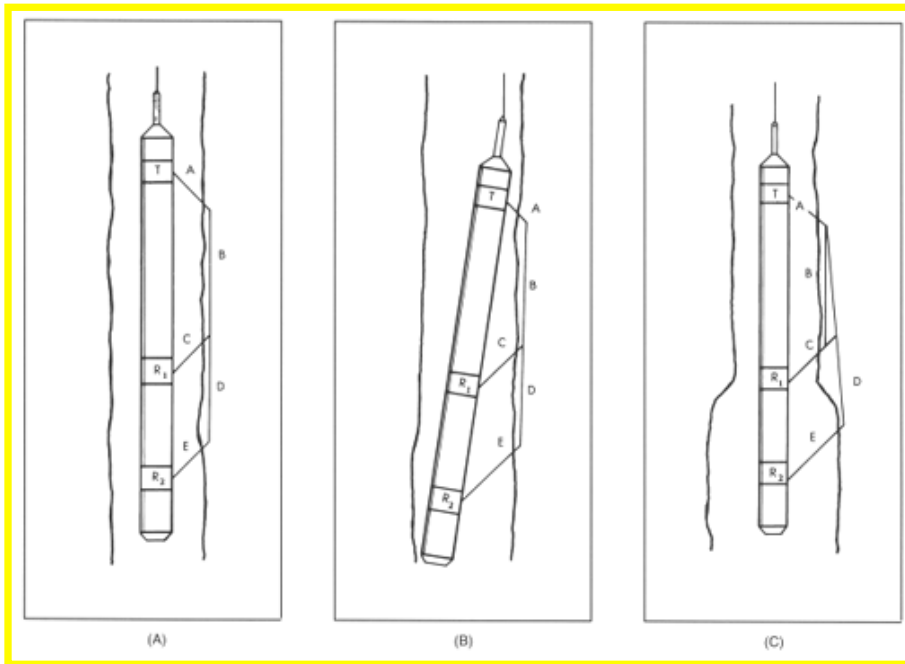

Spaziature Long Spacing
8'-10'/10'-12'

Acoustic log measurements

Acoustic logging tools measure the reciprocal of the acoustic velocity, the interval Transit Time Δt .

Transit Time is measured in $\mu\text{sec}/\text{ft}$, i.e. the time in μsec required to the wave to cross 1 foot of formation.

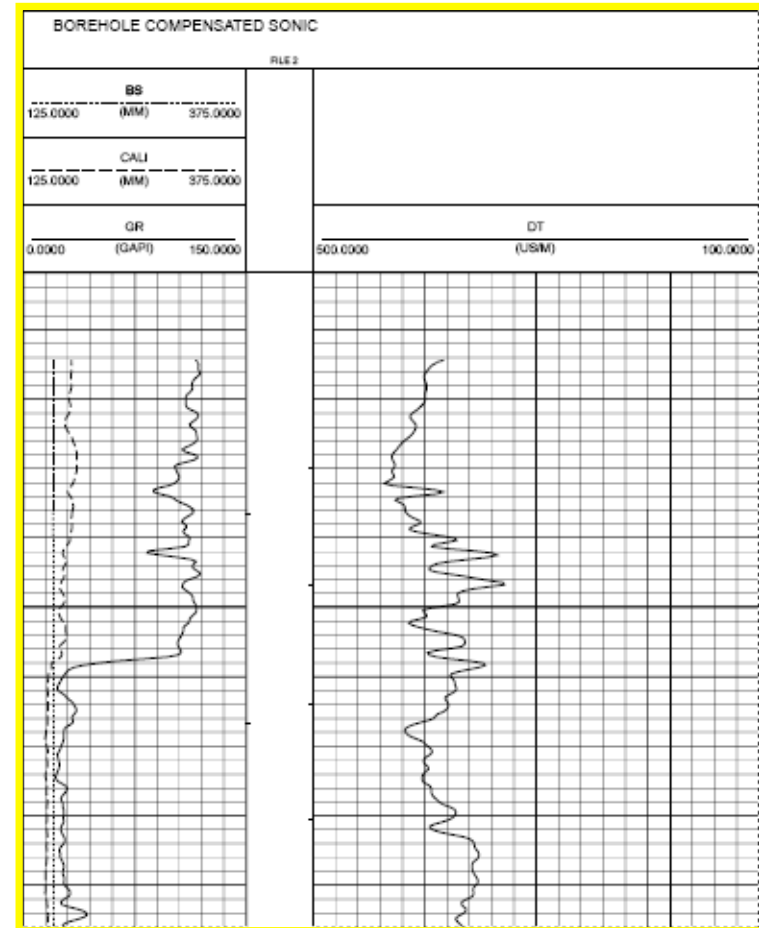

Porosity from Sonic Logs Wyllie equation

$$t_{LOG} = \phi t_f + (1 - \phi)t_{ma}$$

$$\text{or } \phi = \frac{t_{LOG} - t_{ma}}{t_f - t_{ma}}$$

Table 1

	v_{ma} (ft/sec)	Δt_{ma} (μ s/ft)	Δt_{ma} (μ s/ft) (commonly used)
Sandstones	18,000-19,500	55.5-51.0	55.5 or 51.0
Limestones	21,000-23,000	47.6-43.5	47.5
Dolomites	23,000	43.5	43.5
Anhydrite	20,000	50.0	50.0
Salt	15,000	66.7	67.0
Casing (Iron)	17,500	57.0	57.0

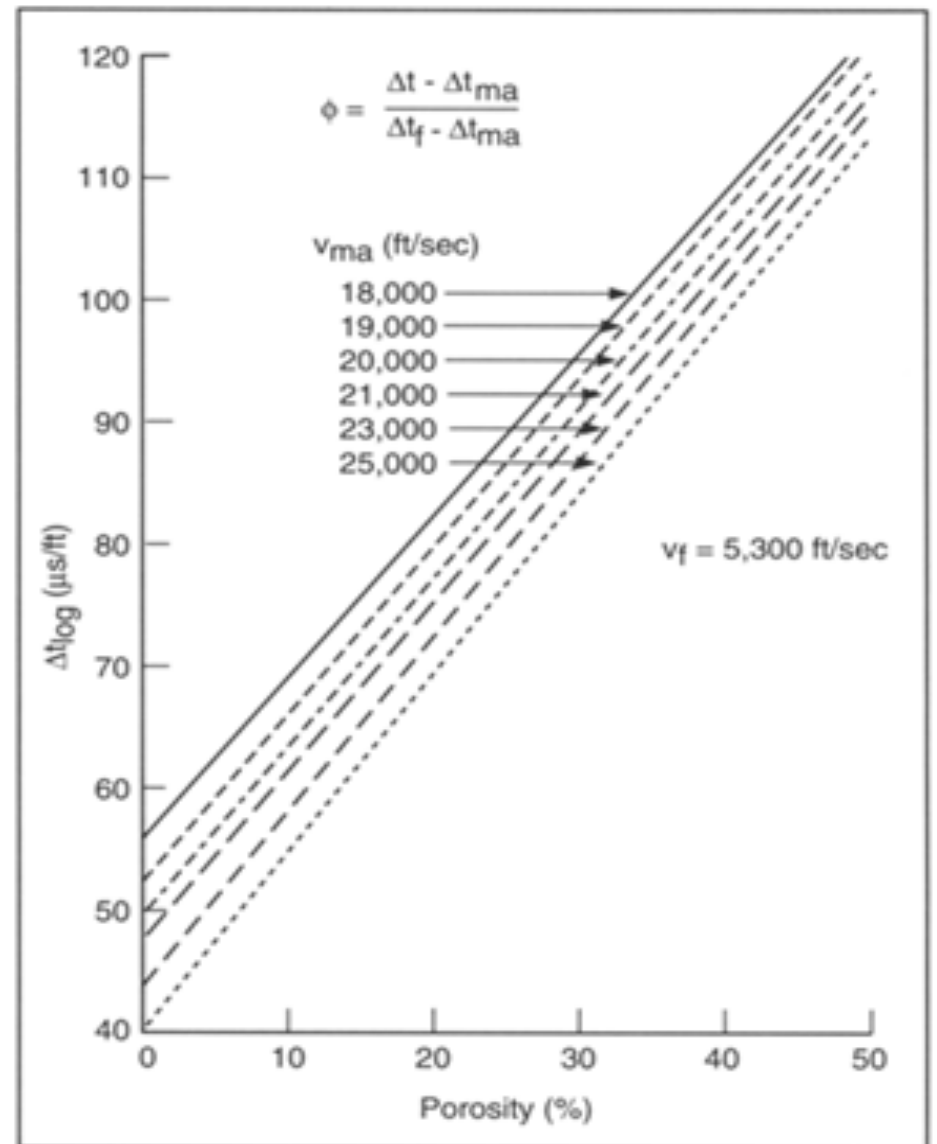

Graphical solution of the time-averaged formula

Porosity from sonic logs: Raimer Hunt equations

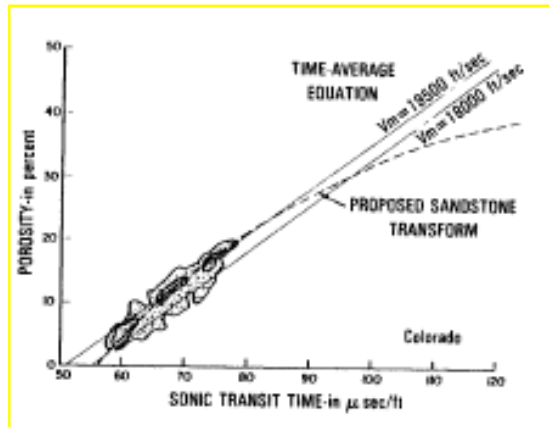

Comparison of sonic transit time to porosity in low-porosity sandstones of a Colorado well.

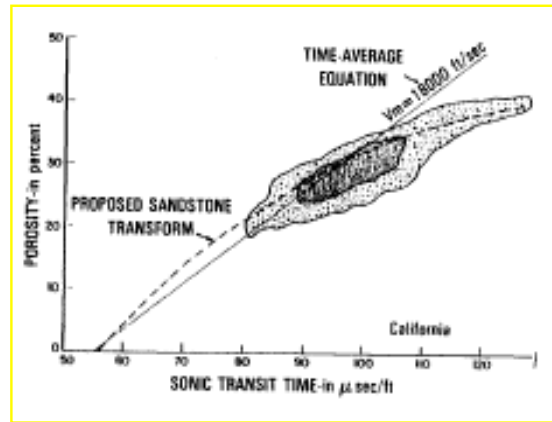

Comparison of sonic transit time to porosity in medium-to-high porosity sandstones of a California well.

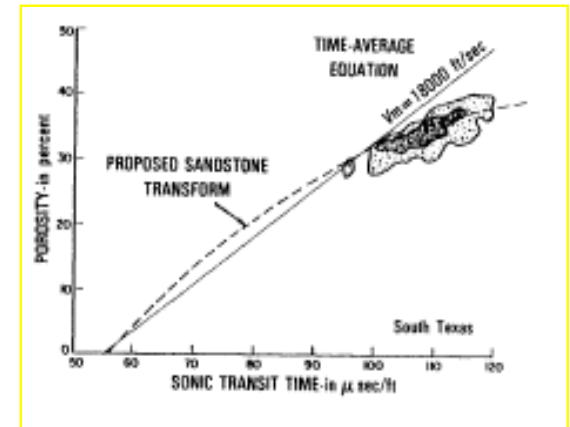

Comparison of sonic transit time to porosity in high-porosity sandstones of a South Texas well.

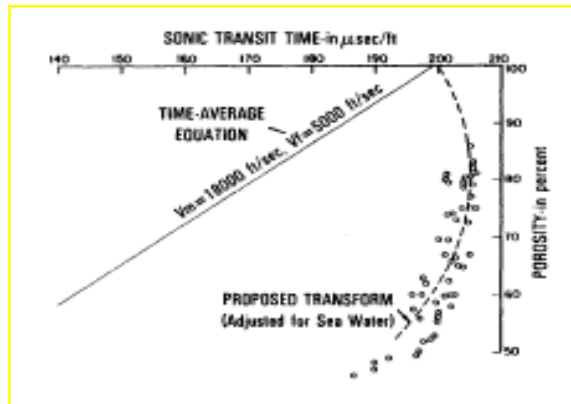

Comparison of transit time to porosity in ocean floor sediments, from data published by Shumway (1960).

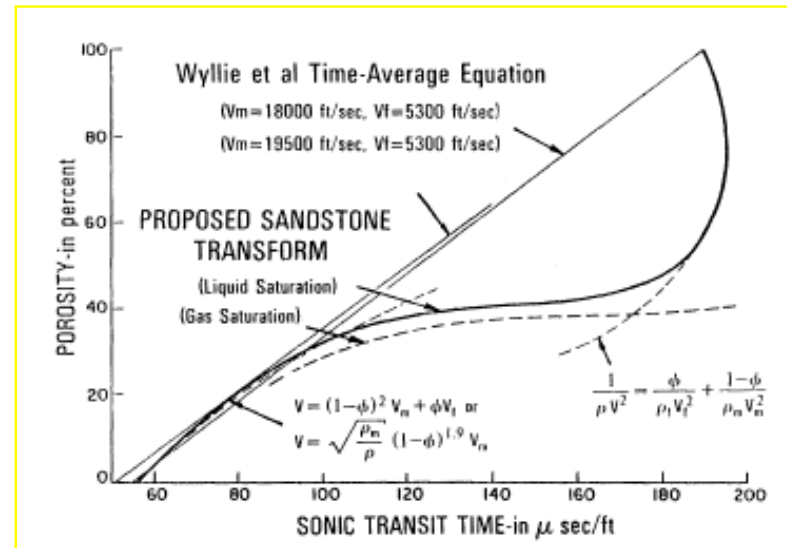

Porosity from sonic: Wyllie vs Raimier Hunt

Raimier Hunt equations are mostly used in unconsolidated formations because they allow for an intrinsic correction of the under-compaction effect.

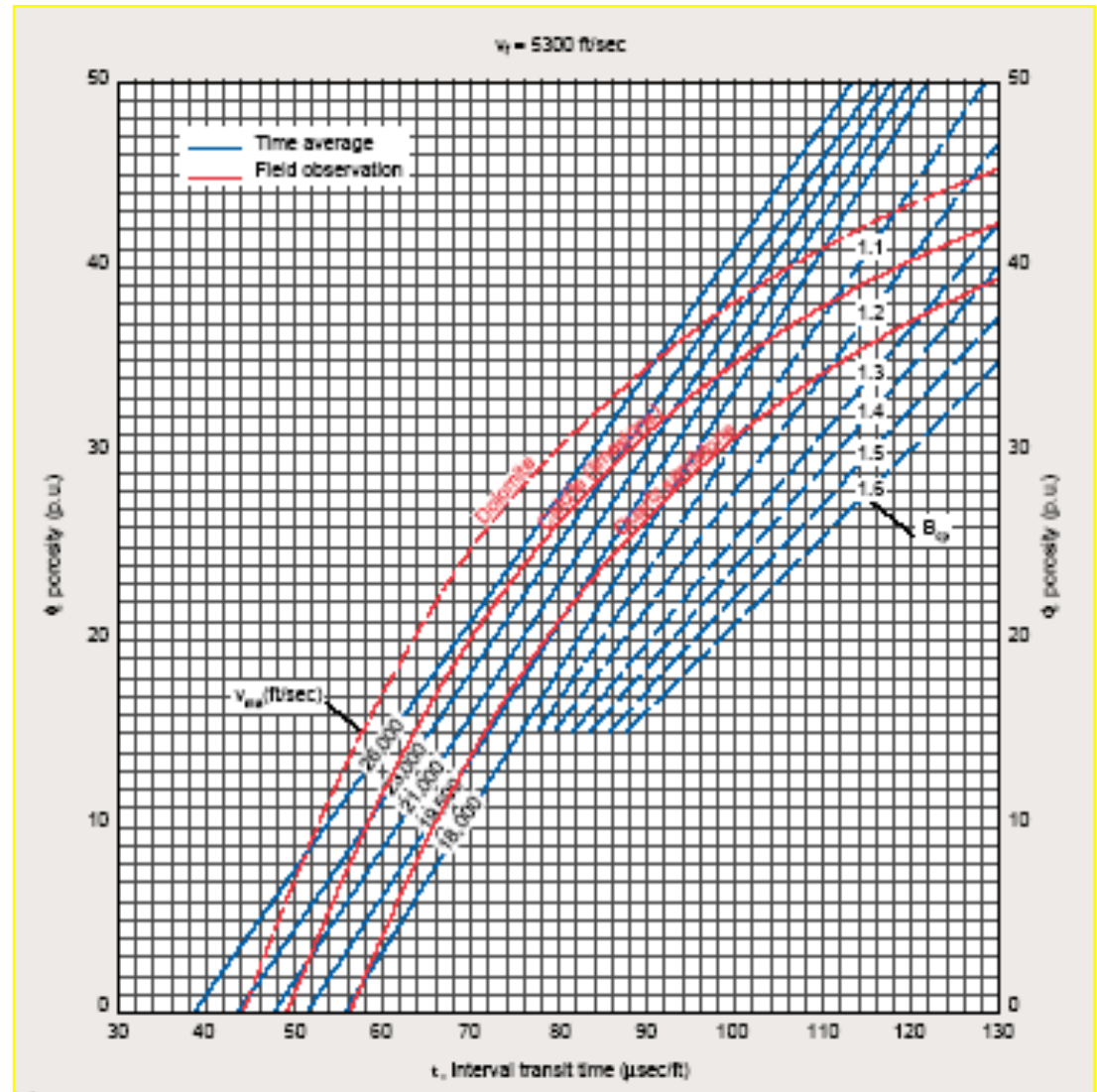

Cycle Skipping on BHC Acoustic Logs in presence of gas

In acoustic transit time or sonic logging when, **due to the attenuation of the acoustic waves generated by the presence of gas**, the amplitude of the first arrival of the acoustic wave train is large enough to be detected by the near receiver of a receiver pair but not large enough to be detected by the far receiver, then one or more cycles will be skipped until a later cycle arrives which has energy above the detection level.

This situation is called "cycle skipping."

Its onset is characterized by a sharp deflection on the transit time curve corresponding to one or more added cycles of time between receivers.

"Short cycle skipping," where the near receiver is triggered a cycle too late can also occur, resulting in an abnormally short travel time (TT).

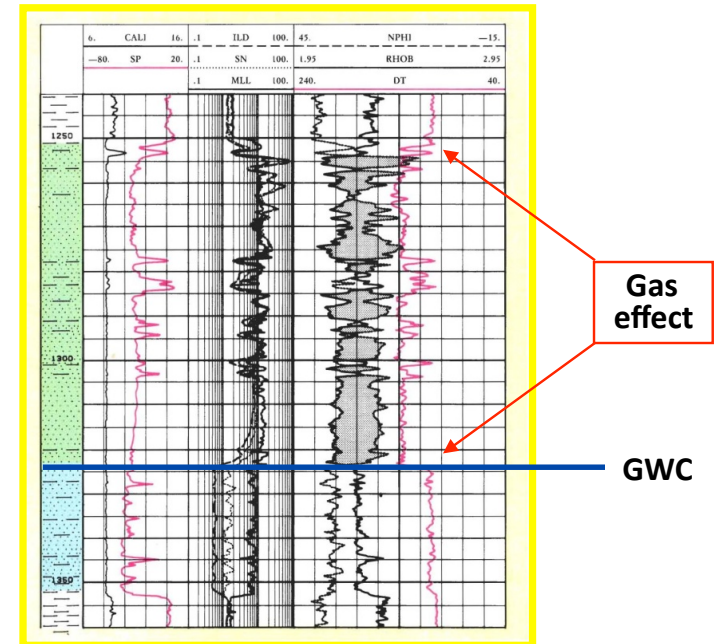

Cycle Skipping on BHC Acoustic Logs in presence of gas

In acoustic transit time or sonic logging when, **due to the attenuation of the acoustic waves generated by the presence of gas**, the amplitude of the first arrival of the acoustic wave train is large enough to be detected by the near receiver of a receiver pair but not large enough to be detected by the far receiver, then one or more cycles will be skipped until a later cycle arrives which has energy above the detection level.

This situation is called "cycle skipping."

Its onset is characterized by a sharp deflection on the transit time curve corresponding to one or more added cycles of time between receivers.

"Short cycle skipping," where the near receiver is triggered a cycle too late can also occur, resulting in an abnormally short travel time (TT).

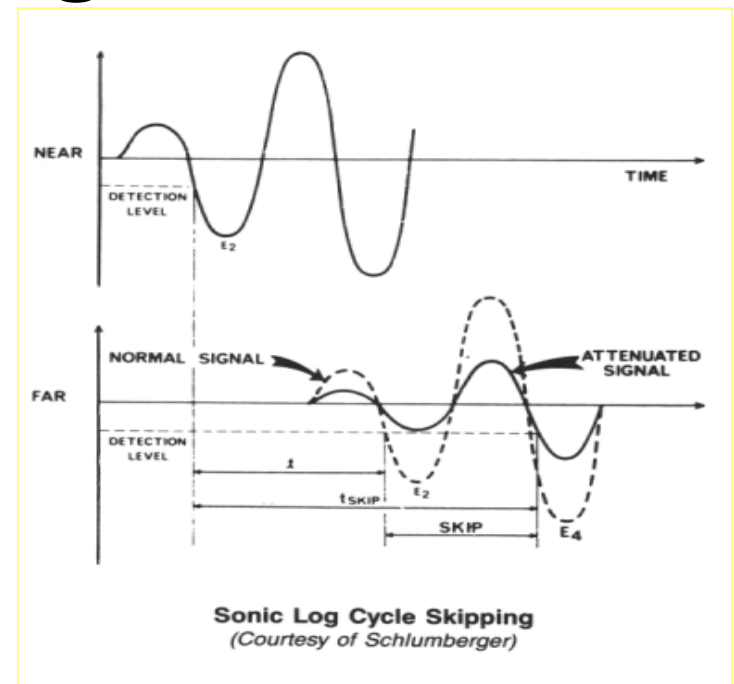

Lithology and porosity determination by means of the Sonic/ Neutron crossplot.

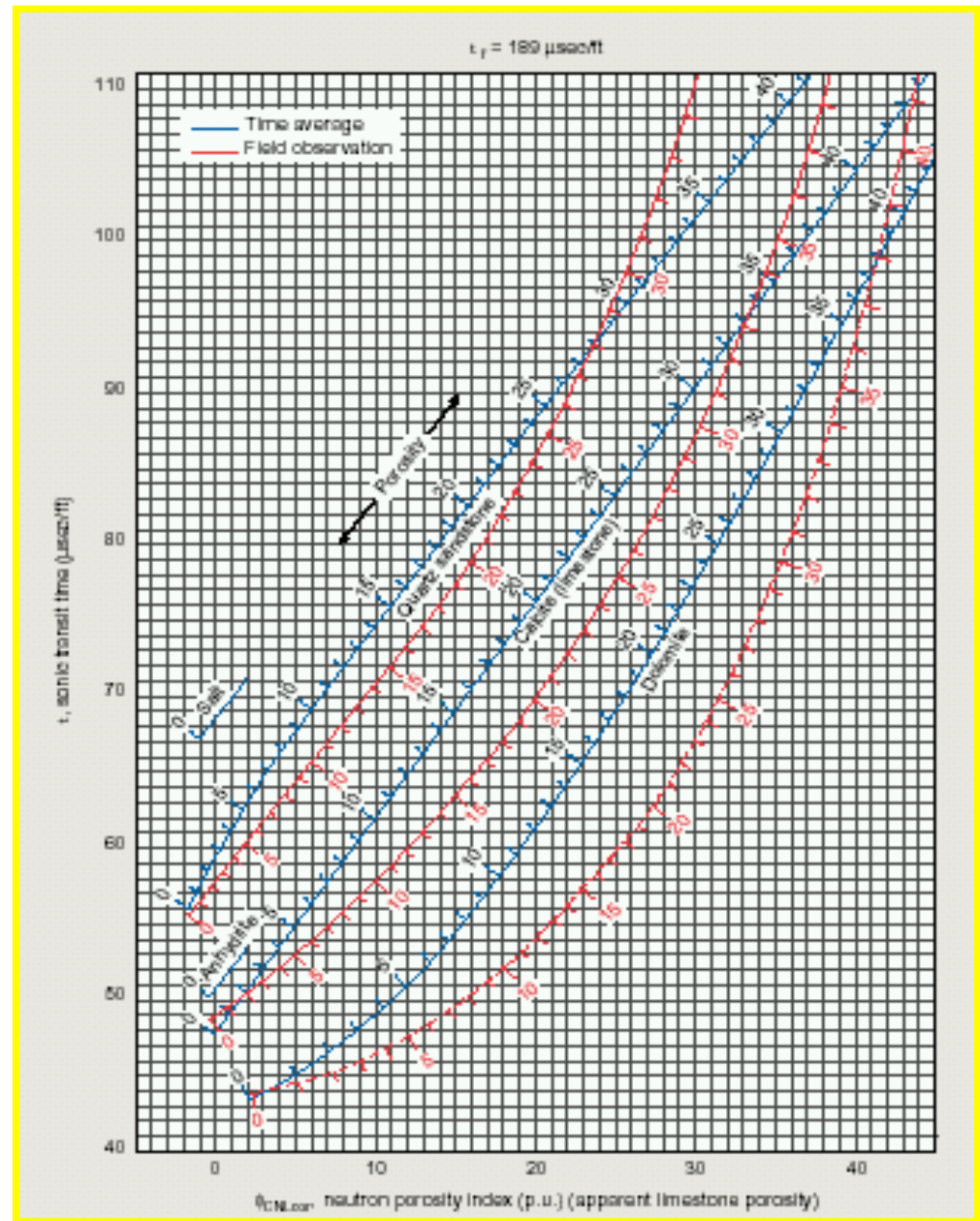

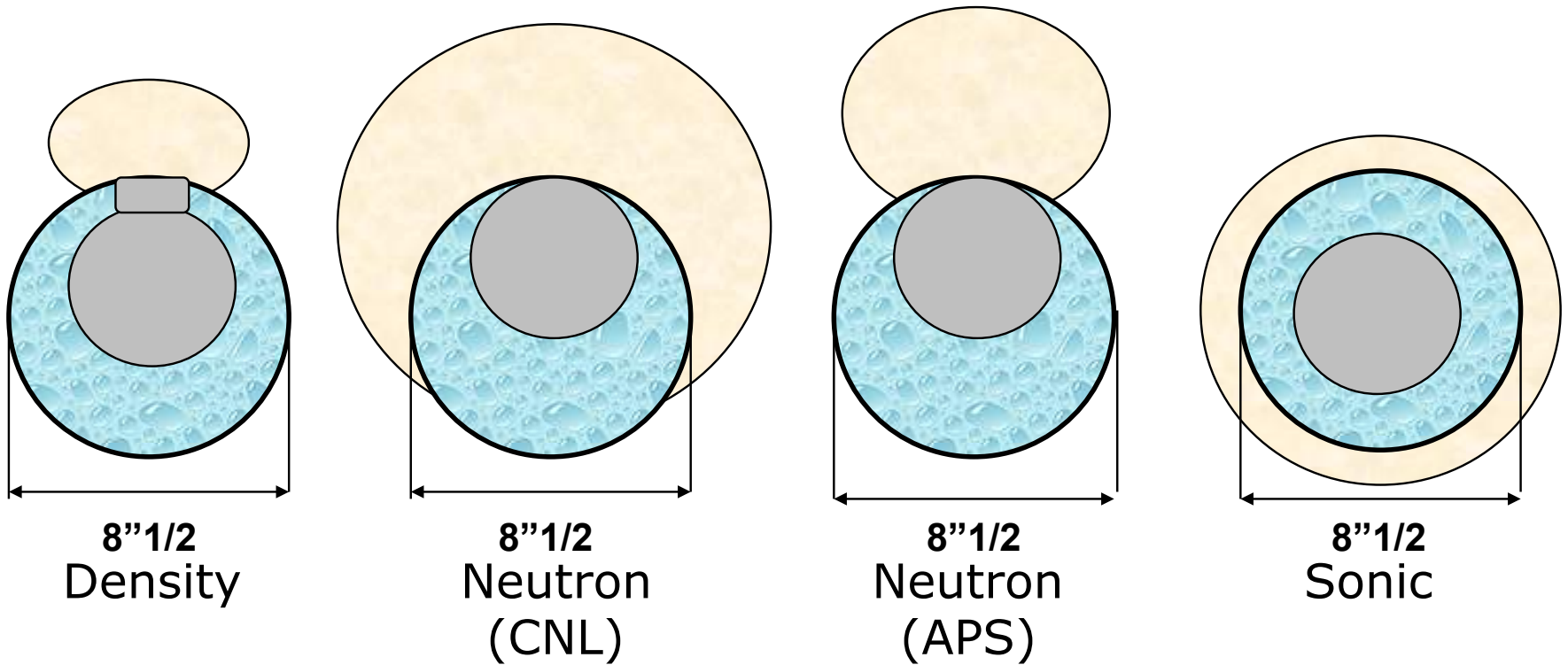

Comparisons among porosity logging tools

	Density	Neutron CNL	Neutron APS	Sonic
Azimuthal aperture (deg.)	45	360	45	360
Depth of investigation (inch)	4	9	7	2
Vertical resolution (ft)	1	2	1	2,5