

Bromodomain proteins, Cancer and Extraterminal Domain Inhibitors (BETi)

**READERS OF HISTONE ACETYLATION:
BROMO DOMAIN PROTEINS**

BET family proteins: a subgroup of Bromodomain proteins

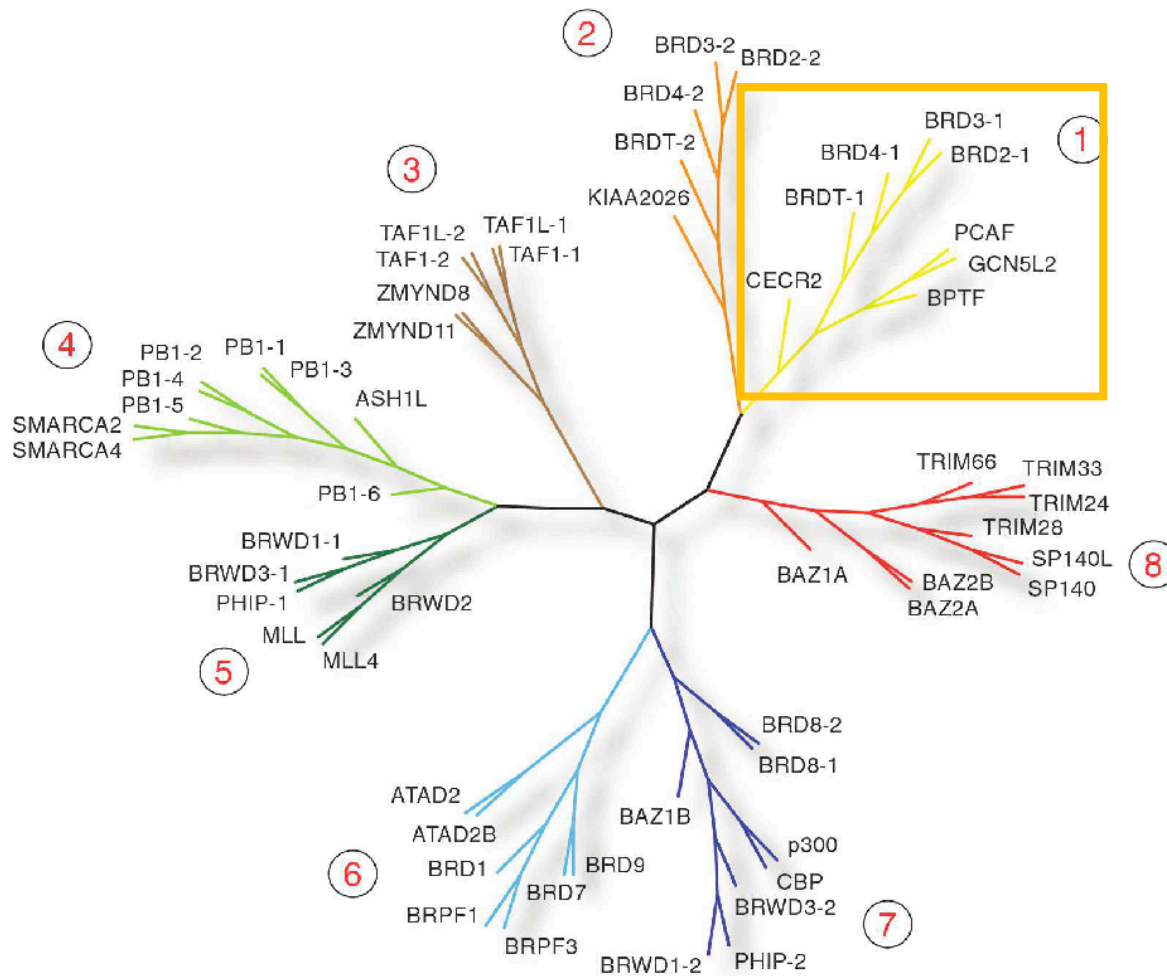

Humans: 43 Bromo-domain proteins

BET proteins:
(Bromo and extraterminal proteins)

- BRD2
- BRD3
- BRD4
- Brdt (testis specific)

BET proteins:

Transcriptional regulators:

- Transcriptional elongation
- Mediator complex

BET family protein organization

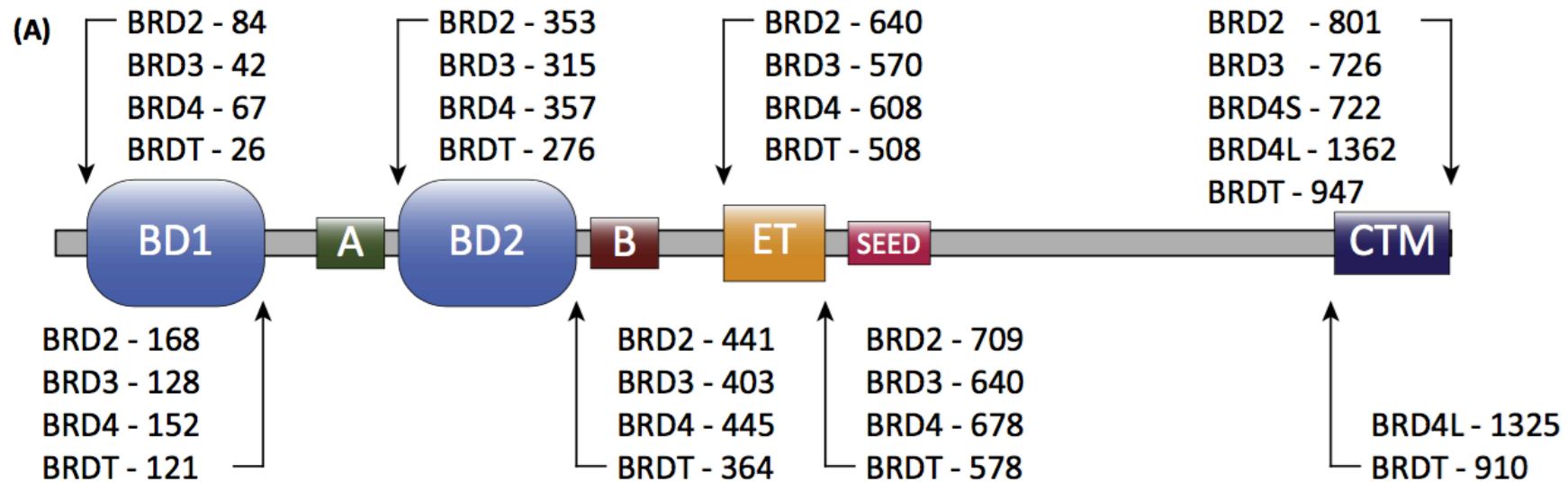

N-terminus: BD1, BD2 tandem bromodomain modules : recognition of acetylated lysines
 ET domain: extra-terminal protein-protein interaction domain
 CTM: C-terminal motif: protein interaction domain (BRD4L, BRDT)

Figure 1. Domain organisation of bromo and extra-terminal (BET) proteins and module structures. (A) BET proteins contain a modular architecture, including two N-terminal tandem bromodomain (BRD) modules (BD1, BD2; shown in blue) responsible for acetyl-lysine recognition and an extra-terminal protein-protein interaction domain (ET; shown in orange). BRDT, as well as the long variant of BRD4 (BRD4L), contains a C-terminal motif (CTM; shown in dark blue) that interacts with the positive transcription elongation factor b (P-TEFb). The CTM is sometimes referred to as P-TEFb-interacting domain (PID). Several conserved motifs are also present (A, B; motifs shown in green and dark red, respectively) as well as a serine-glutamate-aspartate-rich region (SEED). Domain boundaries for all family members are annotated in the figure. (B) Crystal structure of the human BRD2 first BRD module [BD1 or BRD2(1); from PDB ID: 2DVQ] [10]. Structural elements are annotated in the figure and the conserved asparagine is shown in stick representation. (C) Solution structure of the murine BRD4 ET domain (from PDB ID: 2JNS) [5]. Structural elements are annotated in the figure. (D) Crystal structure of human papillomavirus protein E2 in complex with a CTM peptide of BRD4 (residues 1343-1362) showing binding of the BRD4 CTM on a basic groove of the E2 protein [7]. The electrostatic potential of the viral protein is coloured as indicated in the inset. (E) Electrostatic potential of BET BRDs calculated from high-resolution crystal structures of the human [or murine in the case of BRDT(2)] modules [1,8-11]. The structures are oriented with the acetyl-lysine-binding cavity facing outwards, annotated with a dotted circle, and the electrostatic potentials are coloured as indicated in the inset. PDB IDs (<http://www.pdb.org>) are given for each protein module.

BET family proteins: a subgroup of Bromodomain proteins

Bromodomain structure

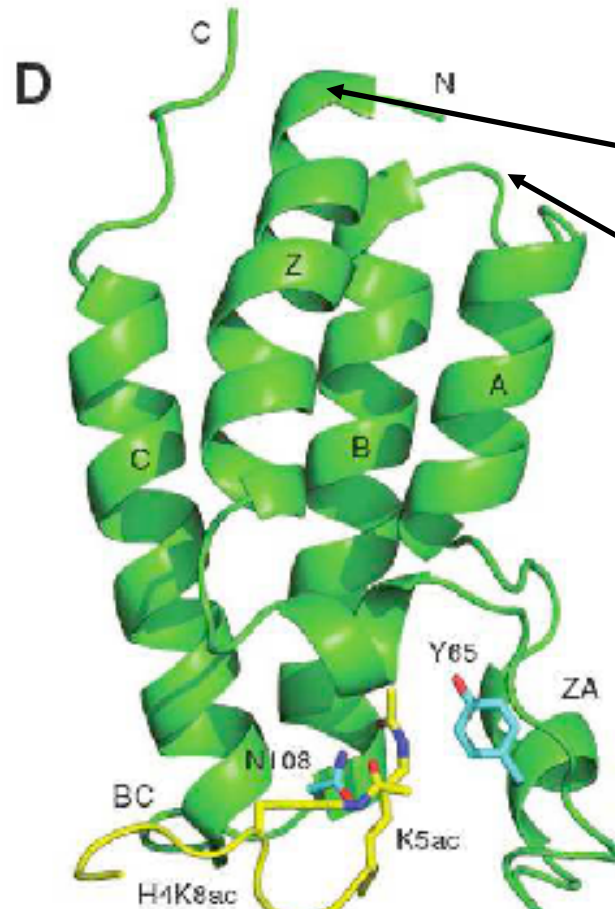

Left-handed **four** helix bundle = BrD fold:

α_Z, α_A : ZA loop
 α_B, α_C : BC loop

} form hydrophobic pocket that binds to acetylated histone

alpha helices are connected by loops

BET family Bromodomain proteins (Brdt, BRD4)

1st bromodomain recognizes 2 acetylated lysine residues in histones

2nd bromodomain recognizes 1 acetylated lysine residue in histone

Brdt + H4K5acK8ac

TAF1 (PDB code: 1EQF). (D) The crystal structure of the first bromodomain of Brdt bound to an H4K5acK8ac peptide (PDB code: 2WP2).

BET family protein organization

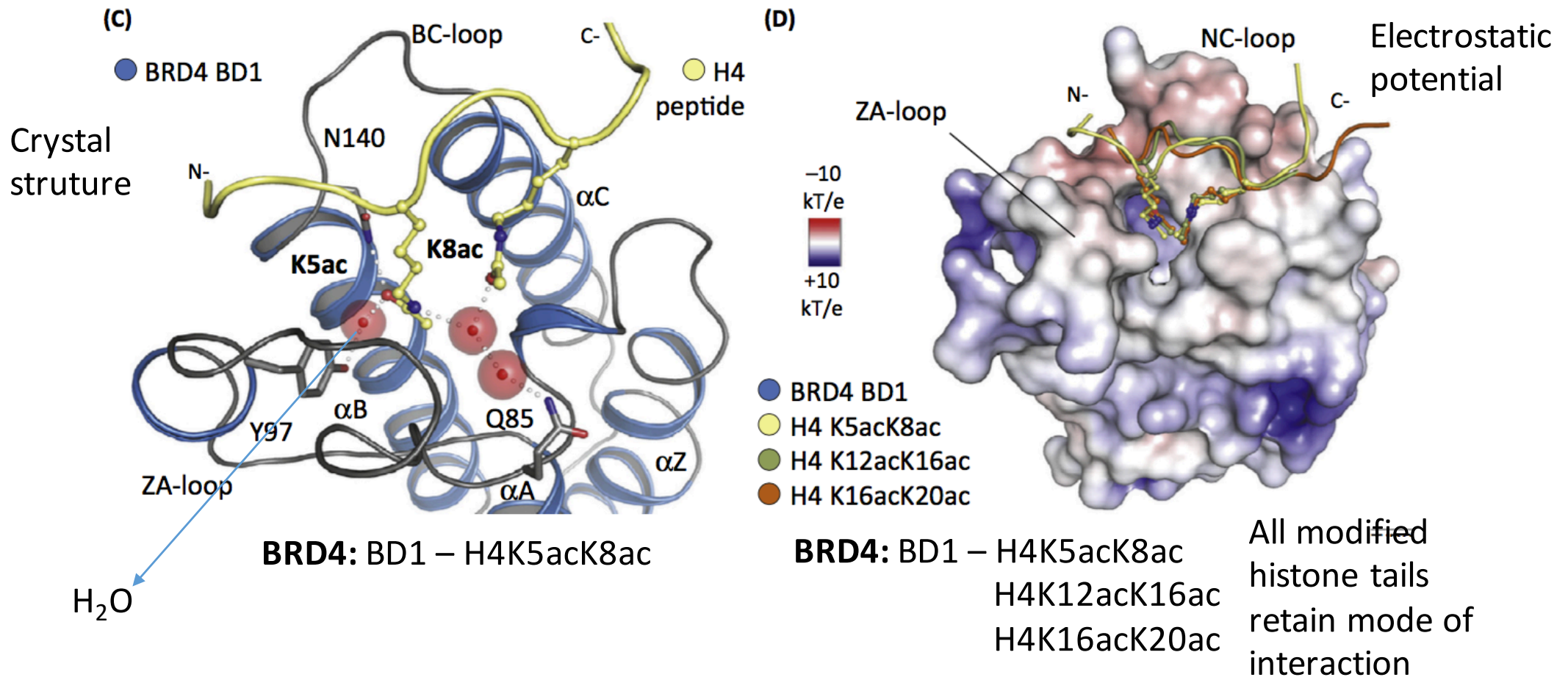

acetylated lysine and the peptide termini have been annotated in the inset. (C) Crystal structure of the first BRD of human BRD4 in complex with a histone H4 diacetylated peptide (at K5 and K8; PDB ID: 3UVW) [1]. While the first acetyl-lysine (K5ac) directly engages the protein via the conserved asparagine residue (N140 in BRD4 BD1) (and is further stabilised via a water-mediated interaction to Y97), the second acetyl-lysine (K8ac) stabilises the peptide fold via water-mediated bridges to K5ac and to BRD4 Q85. (D) Surface representation of the electrostatic potential of human BRD4 BD1 (from PDB ID: 3UVW) in complex with a histone H4 peptide (H4K5acK8ac from PDB ID: 3UVW) superimposed to other double-acetylated peptide complexes of BRD4 BD1 (H4K12acK16ac from PDB ID: 3UVX and H4K16acK20ac from PDB ID: 3UVY). The surface is coloured as indicated in the inset. All three complexes retain the mode of interactions seen in (C) with both acetylated lysines filling the entire recognition cavity. All PDB codes shown are taken from the Protein DataBank (www.pdb.org).

Presence of multiple acetylations on histone tail enhances binding by BD domains in BET family proteins

BET family proteins bind multiple positions at acetylated histone tails

BET family proteins efficiently bind to hyper-acetylated chromatin

	H3				Assay					
	4	9	14	18						
	ART K Q T A K S T G G K A P R K Q L									
mBrdt-BD2 (bac, purified)					+	Peptide binding				
mBrd4 (NE)						+	Peptide binding			
mBrd4-BD1 (bac, purified)							+	Peptide binding		
hBrd4 (293)								+	ChIP assay, IP	
	H4									
	5	8	12	16						
	S G R G K G G K G L G K G G A K R H R									
mBrdt-BD1+2 (NE)						+	+		Peptide binding	
mBrdt-BD1 (bac, purified)						+	+	+	+	Peptide binding
hBrd2 (NE)									+	Peptide binding
hBrd2 & hBrd3 (293, purified)						+			+	IP & <i>in vitro</i> transcription
mBrd4 (NE)						+	+	+	+	Peptide binding
mBrd4 (NIH3T3)						+	+	+	+	ChIP assay
mBrd4 (BMMφs) (BD1 or BD2) (bac, purified)						+	+	+		ChIP assay Peptide binding
mBrd4-BD2 (bac, purified)						+			+	Peptide binding
hBrd4 (HeLa)						+	+	+	+	ChIP assay
hBrd4 (293)									+	ChIP assay & IP
hTAF1-BD1+2 (bac, purified)						+	+	+	+	Peptide binding

BRD4 binds to chromatin in interphase and metaphase

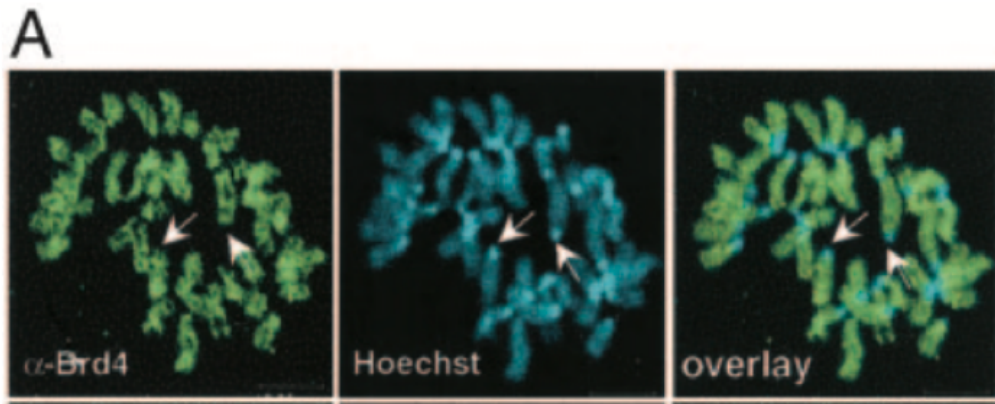

NO Brd4 at centromeres
(heterochromatin –
under-acetylated)

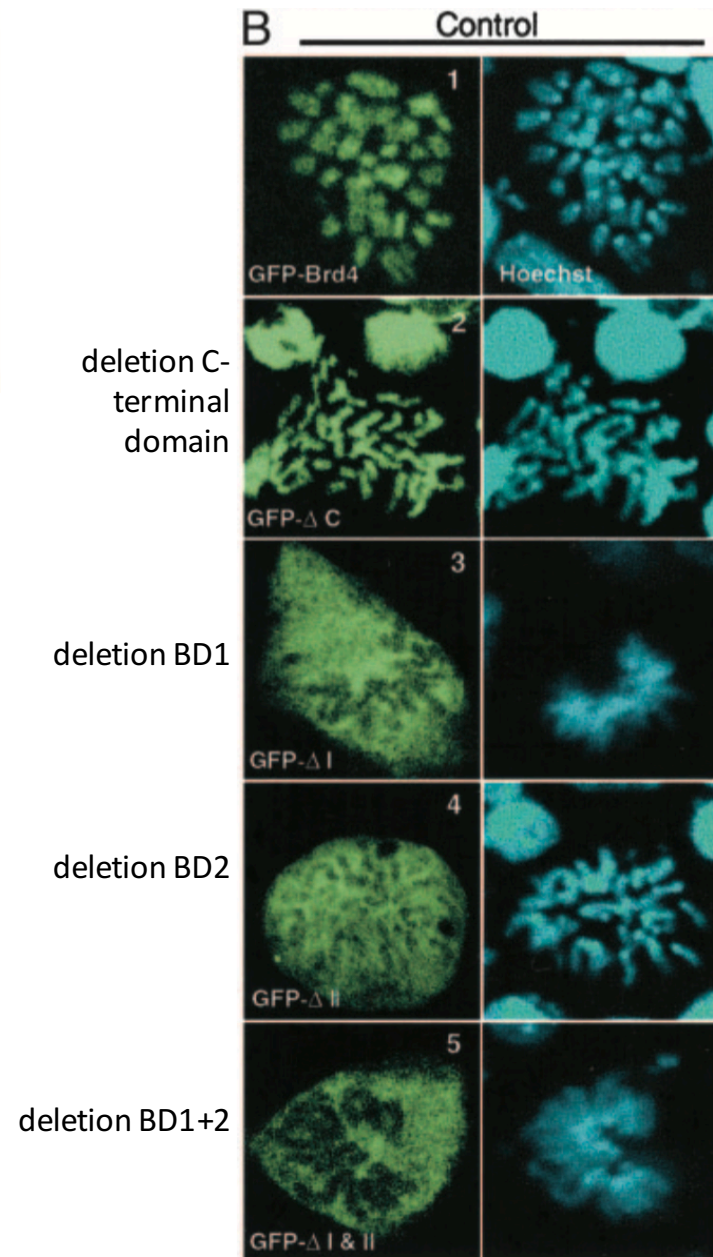

Expression of GFP tagged BRD4 wt and BD deletion Constructs. BD deletion constructs do not bind to chromatin

BRD4 controls gene expression via 2 major pathways

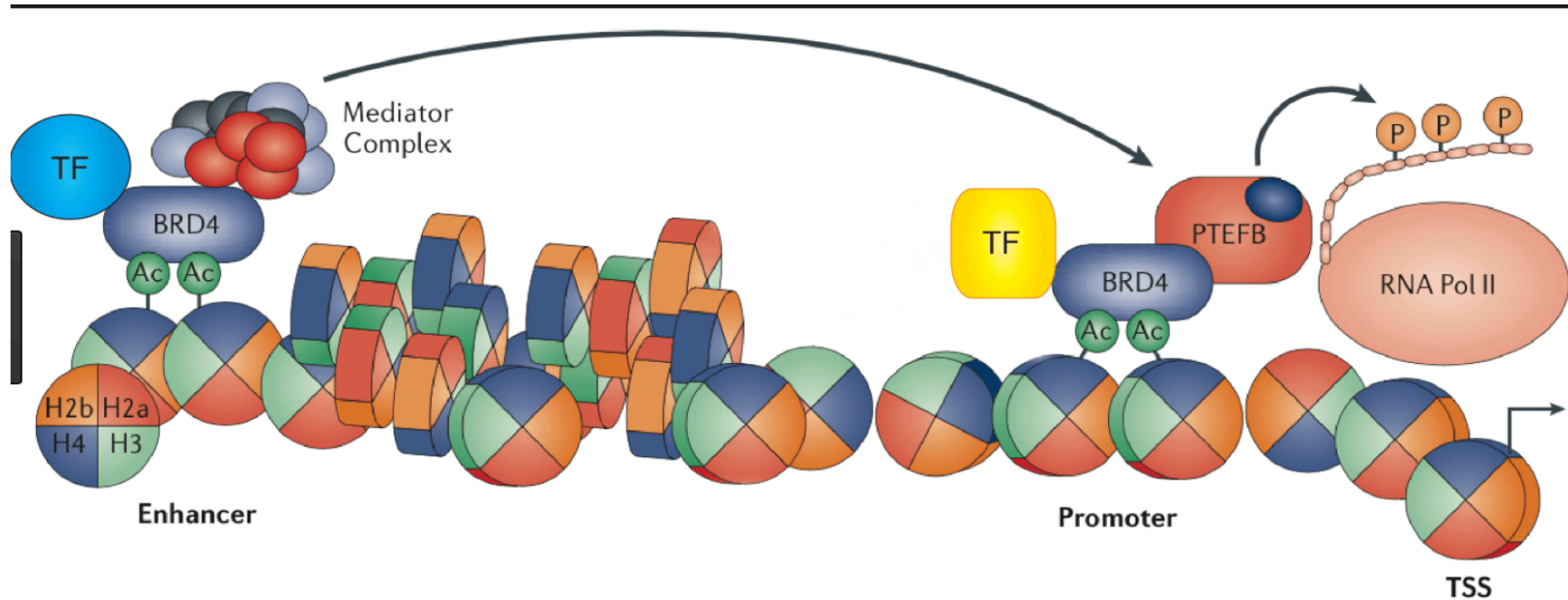

**Enhancer regulation
via the mediator
complex**

**Regulation of processivity
of RNA Polymerase II**

The Mediator complex

- The mediator complex (<20 protein subunits) communicates between promoter and enhancer elements (interconnects transcription factors)
- **Essential for transcriptional activation**

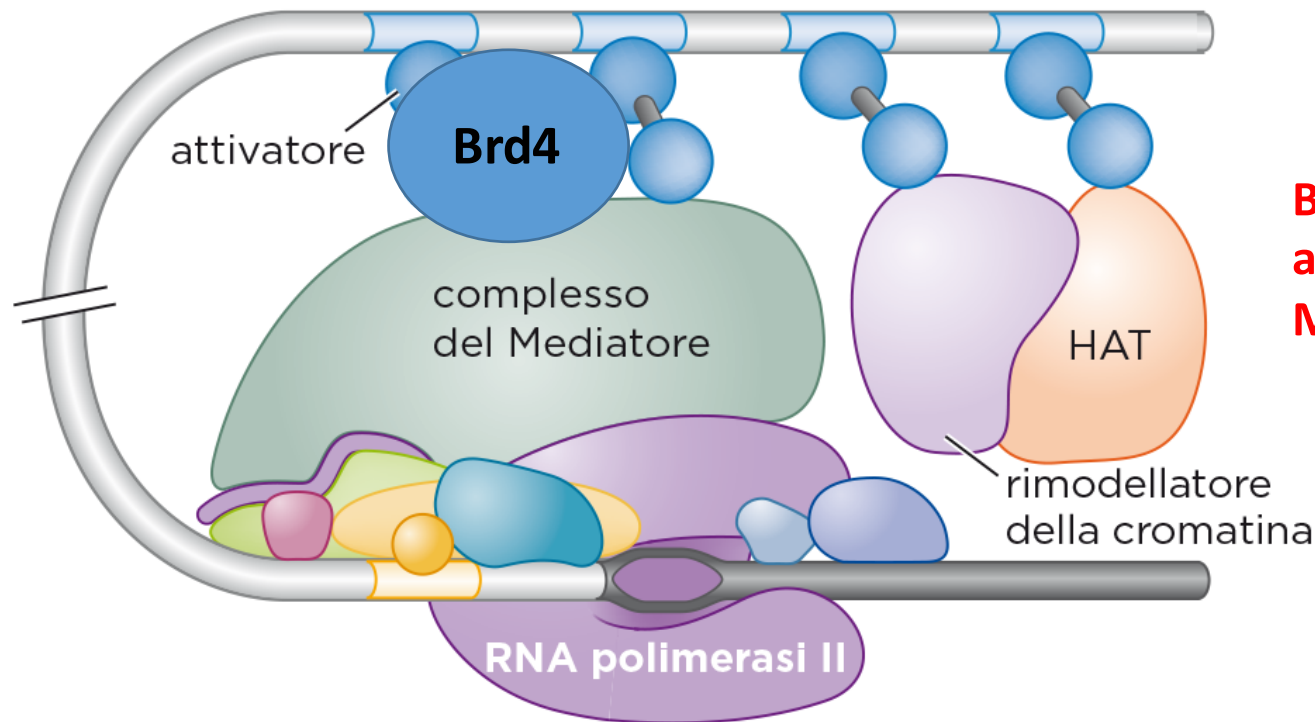

Brd4 was found to be associated with the Mediator complex

LOOP FORMATION BRINGS ENHANCER ELEMENTS TO PROMOTER

→ EFFICIENT ACTIVATION OF TRANSCRIPTION

→ LOOP IS FORMED BY COHESIN PROTEINS

Relevance of BRD4 in Acute Myeloid Leukemia (AML) and Multiple Myeloma (MM)

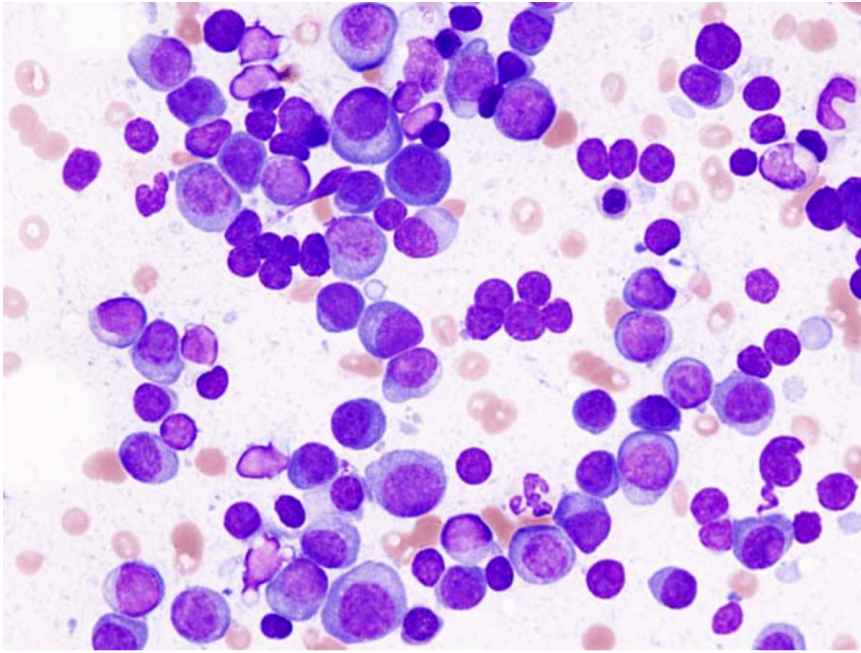

MM

- Multiple myeloma, also known as **plasma cell myeloma**, is a **cancer of plasma cells, a type of white blood cell normally responsible for producing antibodies.**
- Initially, often no symptoms are noticed. When advanced, bone pain, bleeding, frequent infections, and anemia may occur. Complications may include amyloidosis. The cause is generally unknown. Risk factors include drinking alcohol and obesity.
- The underlying mechanism involves **abnormal plasma cells producing abnormal antibodies which can cause kidney problems and overly thick blood.** The plasma cells can also form a mass in the **bone marrow or soft tissue.** When only **one mass is present, it is known as a plasmacytoma** while more than one is known as **multiple myeloma.** Multiple myeloma is diagnosed based on blood or urine tests finding abnormal antibodies, bone marrow biopsy finding cancerous plasma cells, and medical imaging finding bone lesions. Another common finding is high blood calcium levels.
- **Multiple myeloma is considered treatable but generally incurable.** Remissions may be brought about with steroids, chemotherapy, thalidomide or lenalidomide, and stem cell transplant. Bisphosphonates and radiation therapy are sometimes used to reduce pain from bone lesions.

Relevance of BRD4 in Acute Myeloid Leukemia (AML) and Multiple Myeloma (MM)

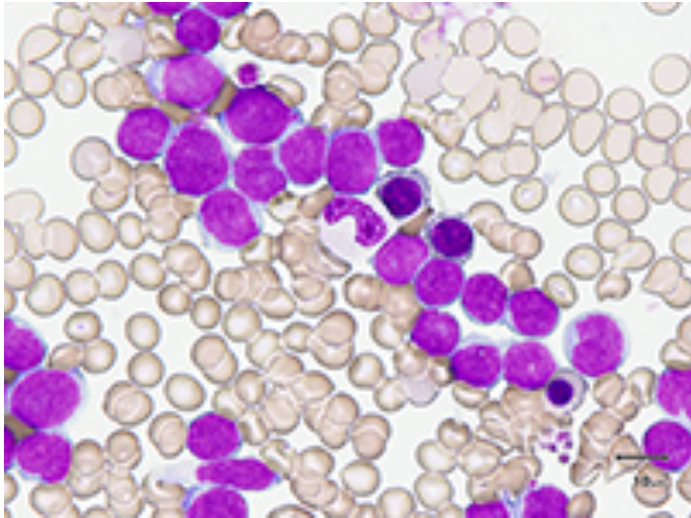

AML

- Acute myeloid leukemia (AML) is a cancer of the **myeloid line of blood cells**, characterized by the rapid growth of **abnormal white blood cells that build up in the bone marrow and interfere with the production of normal blood cells**.
- AML is the most common acute leukemia affecting adults, and its incidence increases with age. Although AML is a relatively rare disease, accounting for roughly 1.2% of cancer deaths in the United States,[4] its incidence is expected to increase as the population ages.
- **The symptoms of AML are caused by replacement of normal bone marrow with leukemic cells, which causes a drop in red blood cells, platelets, and normal white blood cells.** These symptoms include fatigue, shortness of breath, easy bruising and bleeding, and increased risk of infection. Several risk factors and chromosomal abnormalities have been identified, but the specific cause is not clear.
- **As an acute leukemia, AML progresses rapidly and is typically fatal within weeks or months if left untreated.** AML has several subtypes; treatment and prognosis vary among subtypes. AML is cured in 35–40% of people under 60 years old and 5–15% over 60 years old. Older people who are not able to withstand intensive chemotherapy have an average survival of 5–10 months.

QUESTION: CAN WE IDENTIFY COMPLETELY NEW TARGETS FOR THE TREATMENT OF AML

AN UNBIASED SCREEN FOR EPIGENETIC REGULATORS WITH RELEVANCE FOR AML

243 genes involved in chromatin modification

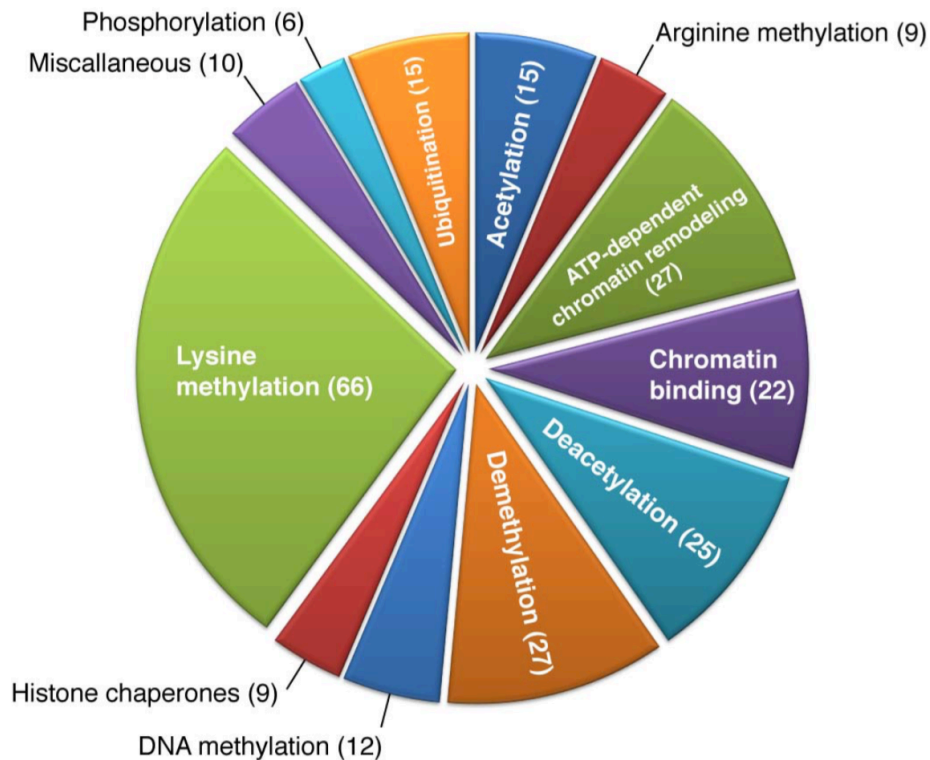

Supplementary Figure 1. Categories of chromatin regulators evaluated in the RNAi screen. Numbers indicate the number of genes in each category. For each gene, 6 shRNAs were designed using the BIOPREDsi algorithm¹, and adapted for the miR30-context. The library was constructed using large-scale on-chip oligonucleotide synthesis, followed by pooled PCR cloning and sequence verification of individual clones, which yielded a total of 1094 shRNAs (3-6 per gene). All shRNA sequences are provided in Supplementary Table 1.

A lentivirus shRNA library to target 243 epigenetic regulators

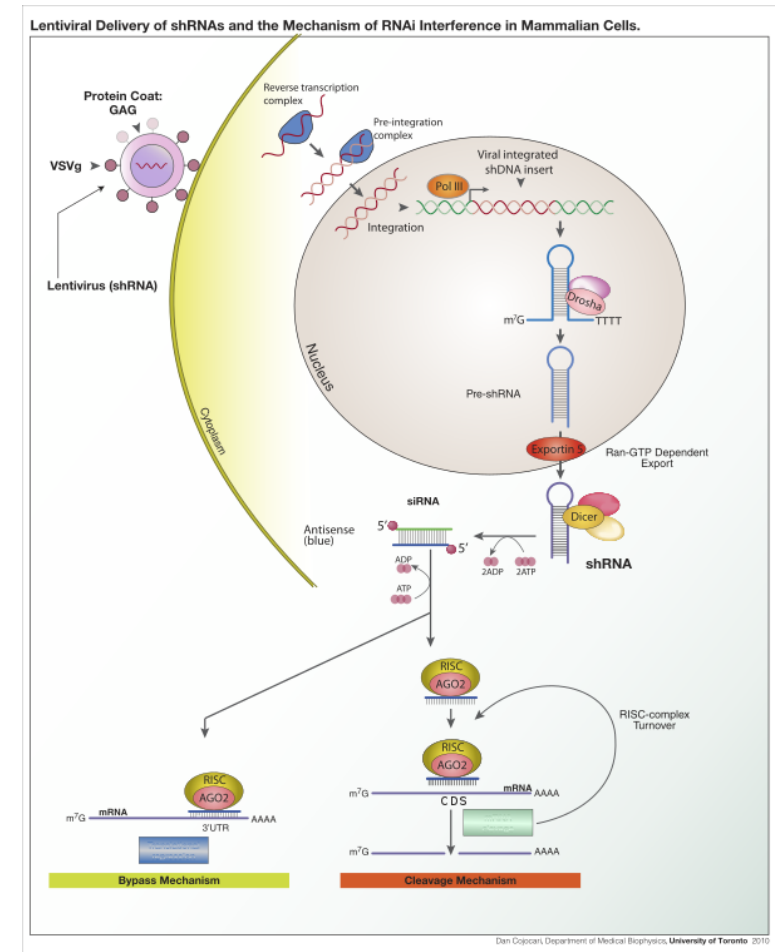

https://en.wikipedia.org/wiki/Short_hairpin_RNA https://en.wikipedia.org/wiki/Short_hairpin_RNA

Zuber et al. 2011

An intelligent RNAi screening strategy to identify important epigenetic regulators in AML

a

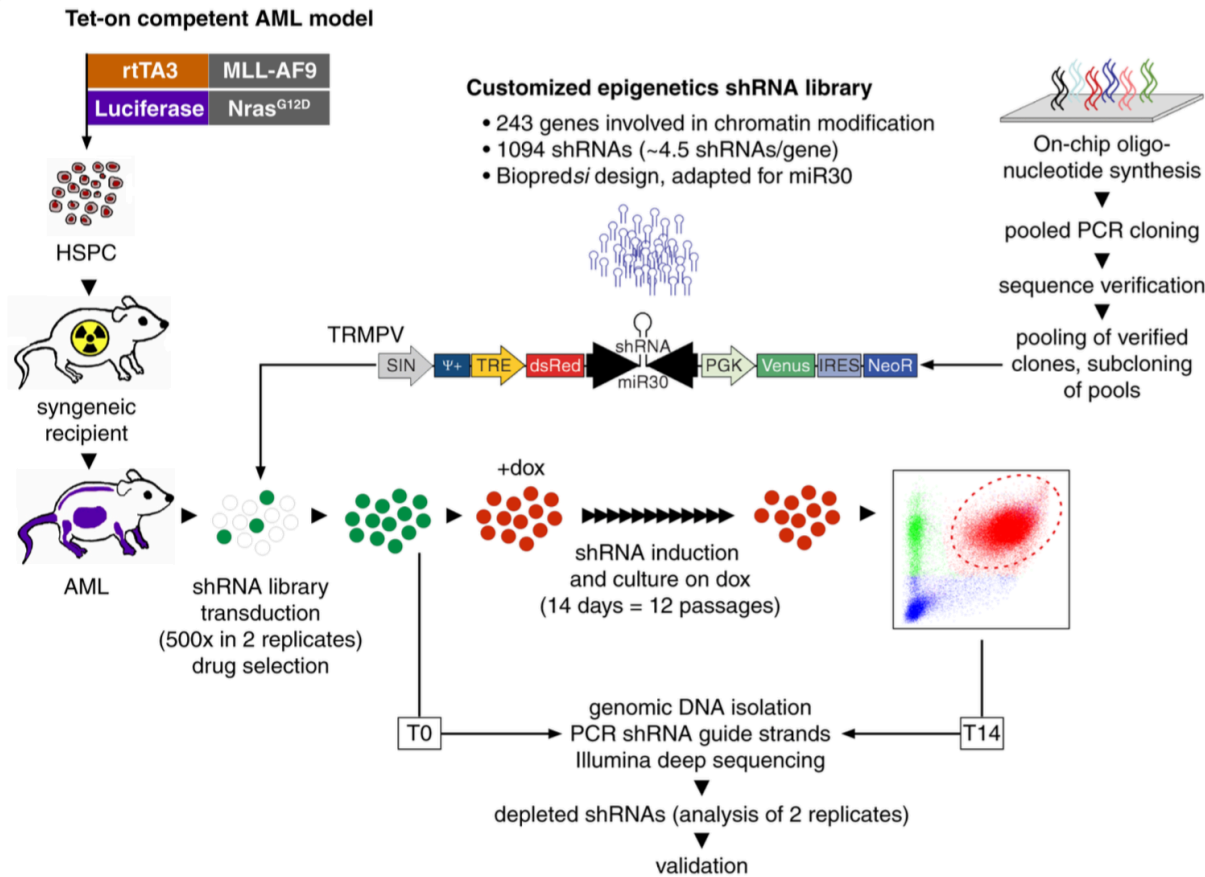

Transactivator for the Doxycyclin inducible gene expression system +

Nras^{G12D} inserted into mouse haematopoietic stem cells.

Expression of luciferase.

(inserted by retrovirus)

MLL-AF9 fusion gene is associated with aggressive leukemias of both the myeloid and lymphoid lineage

(inserted by retrovirus)

Injection in immune-compromised mice

Formation of AML

Isolation of AML cells by cell sorting

Transduction of AML cells with the retroviral shRNA library (directed against epigenetic regulators) – selection for presence of shRNA vector (G418)

Cultivate cells in medium containing doxycyclin to induce shRNA expression (shRNAs are under the control of a Dox inducible promoter) for 14 days

Isolate cells that are dsRed and Venus positive (fluorescent proteins produced by shRNA vector)

Deep sequence shRNA vector inserts of in cell populations: -Dox and +Dox (i.e. shGeneX)

$$\frac{\#reads\ shGeneX\ +Dox\ (T14)}{\#reads\ shGeneX\ -Dox\ (T0)} < 1$$

Gene X is important for AML (shRNA reduces AML cell viability)

$$\frac{\#reads\ shGeneX\ +Dox\ (T14)}{\#reads\ shGeneX\ -Dox\ (T0)} = / > 1$$

Gene X is NOT important for AML (shRNA vector does not reduce AML viability)

Supplementary Figure 2. RNAi screening strategy. a) The screen was performed in a Tet-on competent AML model generated by retroviral cotransduction of vectors encoding rTA3-IRES-MLL-AF9 and Luciferase-IRES-Nras^{G12D} into hematopoietic stem and progenitor cells (HSPC). Leukemic cells retrieved from terminally ill mice were placed in culture and utilized for the screen. A customized shRNA library targeting chromatin regulating genes was synthesized using On-chip oligonucleotide synthesis, and cloned in a pooled format. A library pool of 1094 sequence verified shRNAs was subcloned into TRMPV-Neo² and transduced into leukemia cells, followed by G418 selection. The selected cell population (T0) was then treated with doxycycline for 14 days (equivalent to 12 cell passages), followed by FACS isolation of Venus+/dsRed+ (shRNA-expressing) cells (T14). Genomic DNA isolated from T0 and T14 populations was used as a template for PCR amplification of shRNA guide strands, which were subjected to deep-sequencing to quantify the relative abundance of each shRNA in the library. Top hits were defined in the screen as genes for which at least two shRNA showed >20fold depletion in 2 independent replicates. 38 genes satisfied these criteria and were subjected to 1-by-1 validation using a different MLL-AF9/Nras^{G12D} induced AML cell line and a constitutive shRNA expression vector (LMN). **b)** Scatter

BRD4 shRNAs are under-represented in AML cells after the RNAi screen

Positive control genes are underrepresented (involved in DNA replication):

- Rpa1
- Rpa3
- PcnA
- Polr2b

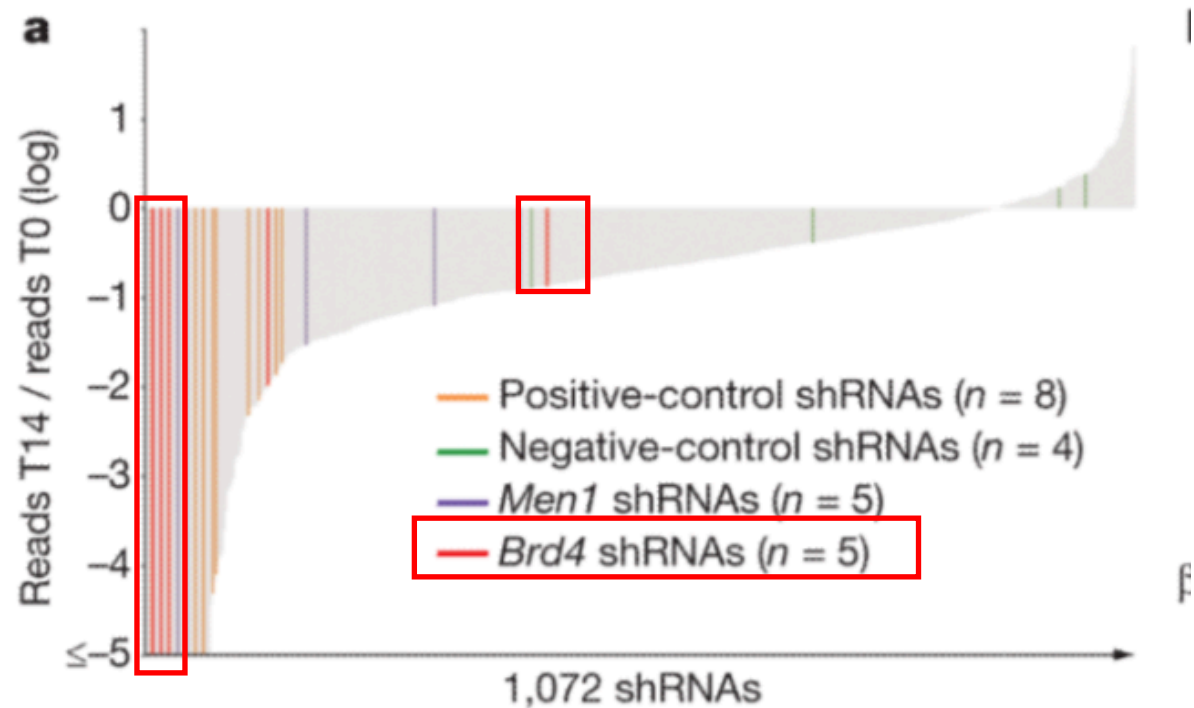

→ shBRD4 vectors in genomic DNA of AML cells are under-represented

→ AML cells that express shBRD4 are eliminated during the 14 day experiment

→ BRD4 is important for the survival of AML cells

BRD4 shRNAs are under-represented in AML cells after the RNAi screen

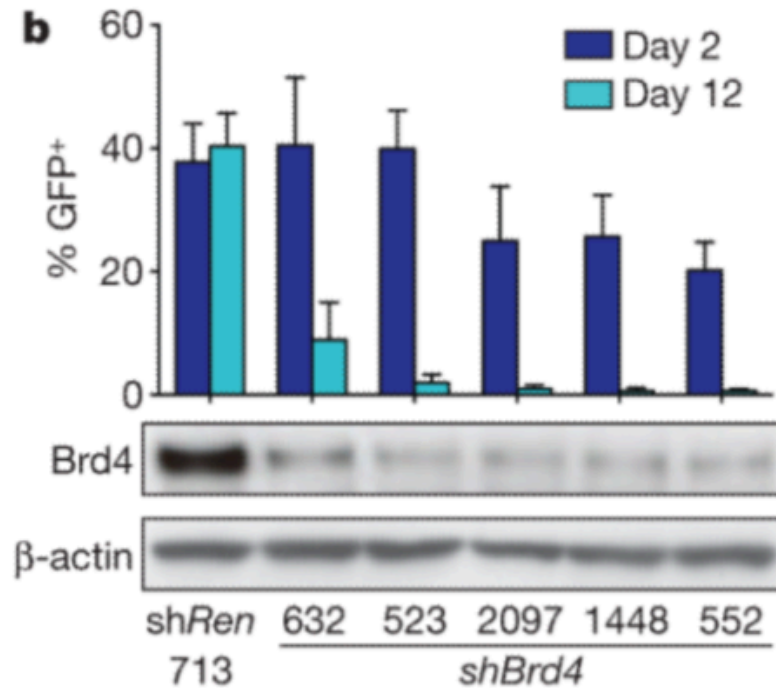
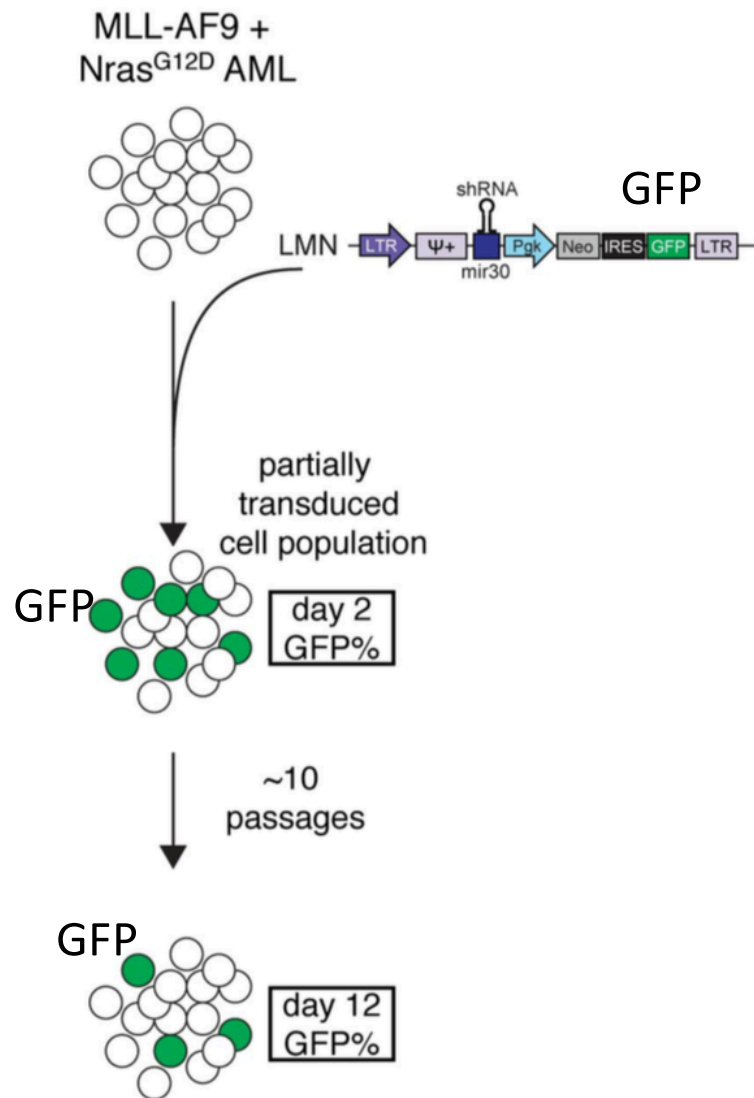

A control experiment:

CONSTITUTIVE expression of shRNA Brd4 vector in AML cells - shRNA vector contains GFP marker.

AML populations are transduced at ca. 40%.

After 12 days GFP+ cells are reduced → lack of Brd4 expression → GFP positive cells eliminated

JQ1 is an efficient inhibitor of BRD4

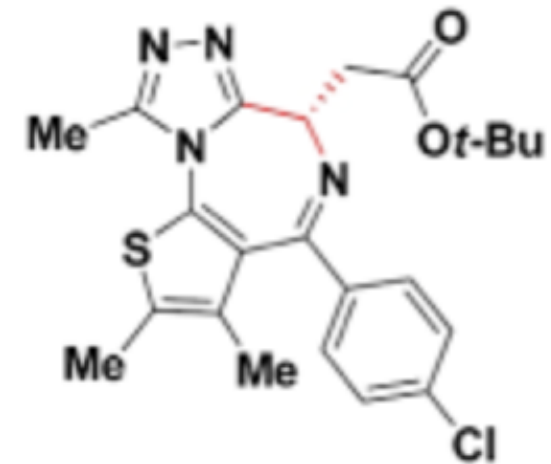
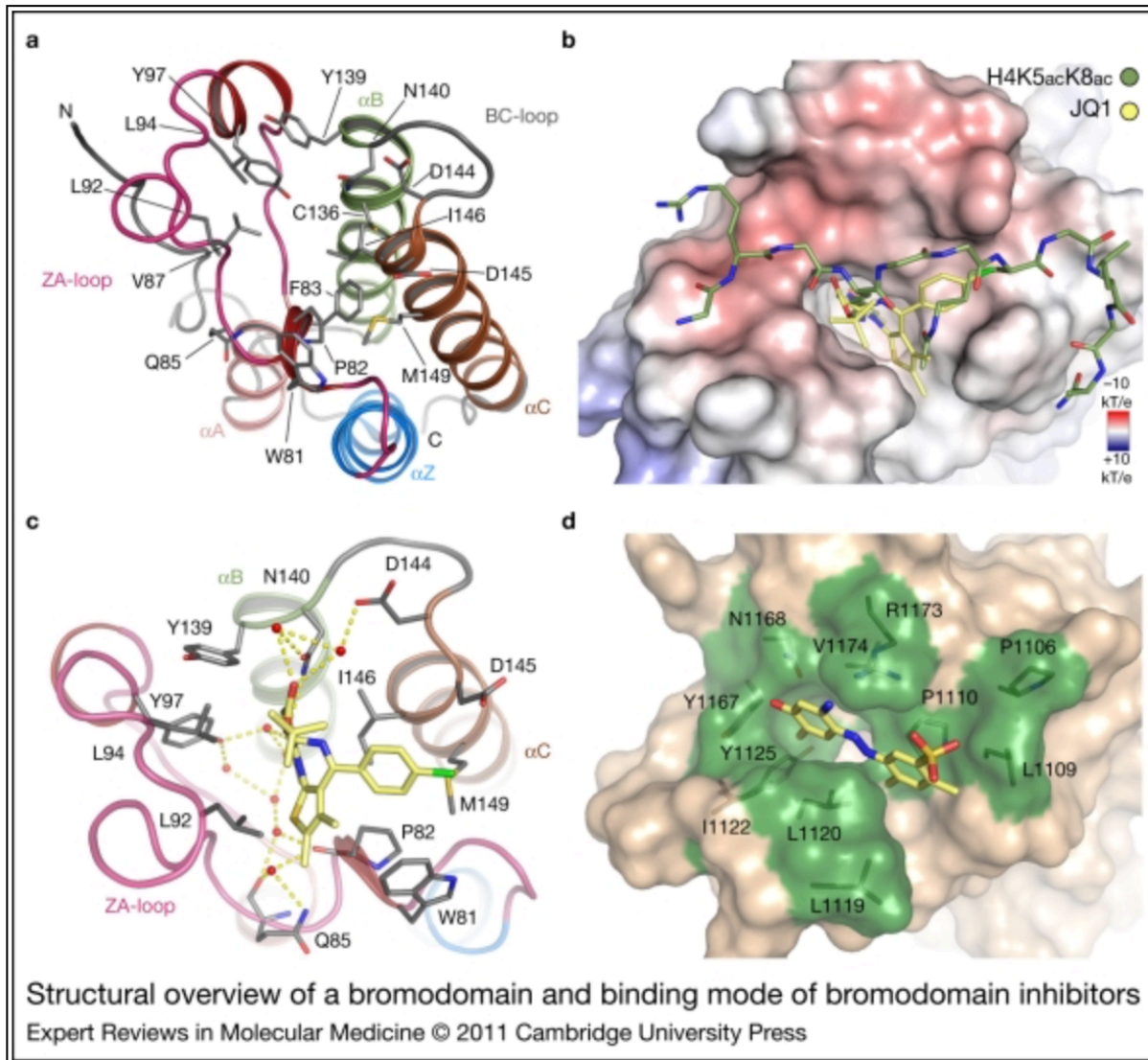

JQ1

JQ1 targets BET family proteins

JQ1 competes with acetylated peptides

JQ1 has higher affinity to BRD4 (0,1 – 10nM) than histone tails (μM range)

Figure 3: Structural overview of a bromodomain and binding mode of bromodomain inhibitors. (a) Ribbon diagram of the first BRD of BRD4. The main structural elements as well as the acetyl lysine binding site residues are labelled. (b) Superimposition of a diacetylated BET substrate peptide and the inhibitor JQ1. Inhibitor and peptide molecules are shown in stick representation and are coloured according to atom types. (c) Binding of JQ1 to the bromodomain of BRD4. Conserved water molecules in the active site are highlighted and hydrogen bonds are shown as dashed lines. (d) Complex of ischemin with CREBBP (Ref. 176).

JQ1 treatment specifically kills AML cell lines (established)

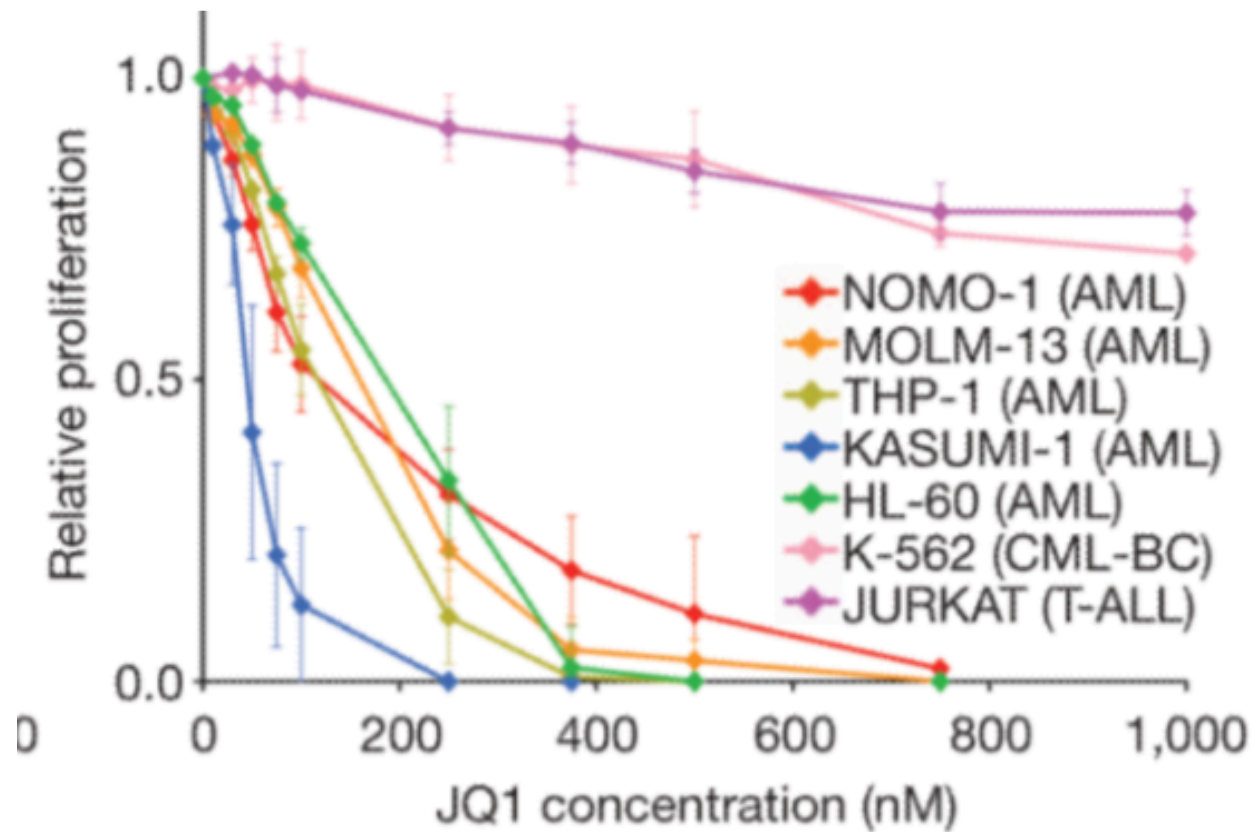

JQ1 treatment blocks AML in a preclinical mouse model

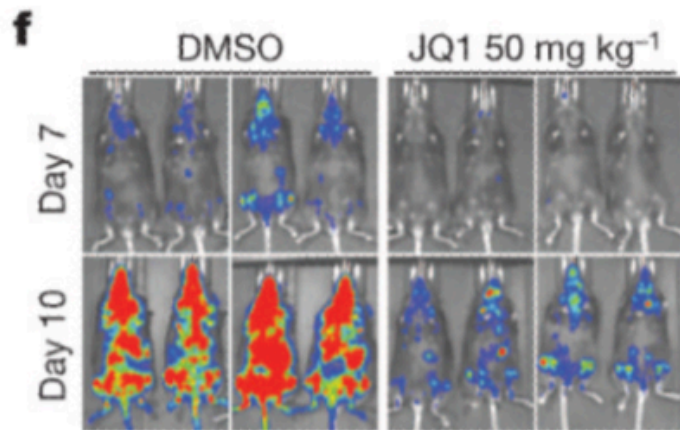

Haematopoietic stem cells transduced with retroviral vector encoding NrasG12D and a luciferase vector.

Cells are injected into an irradiated animal. Mice are untreated or JQ1 treated. AML cells (NrasG12D + luciferase) can be visualized using a luciferase luminescence reader. Bioluminescent imaging of MLL-AF9/NrasG12D leukemia recipient mice at the indicated day after initiation of treatment with JQ1 (50 mg⁻¹ kg⁻¹ d⁻¹) or DMSO carrier.

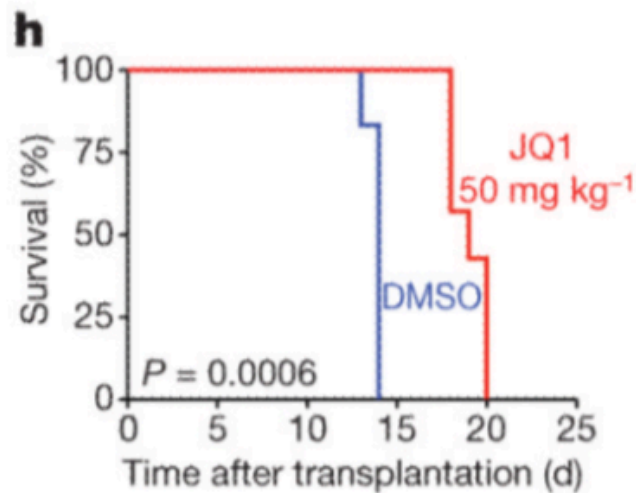

Kaplan-Meier survival curves of control and JQ1-treated mice. Statistical significance was calculated using a log-rank test.

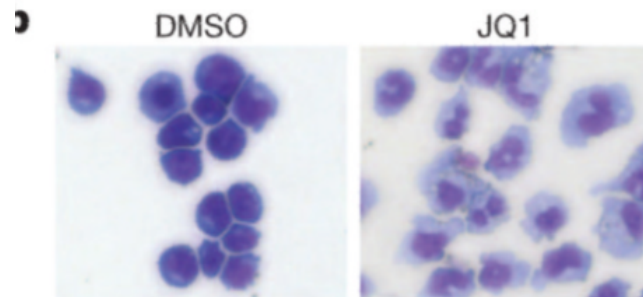

Light microscopy of May-Grünwald/Giemsa-stained MLL-AF9/NrasG12D leukaemia cells after 2 days of JQ1 treatment (100 nM).

HOW IS JQ1 AND BRD4 CONNECTED TO ONCOGENES/TUMORSUPPRESSION?

BRD4 is required for Myc expression in AML

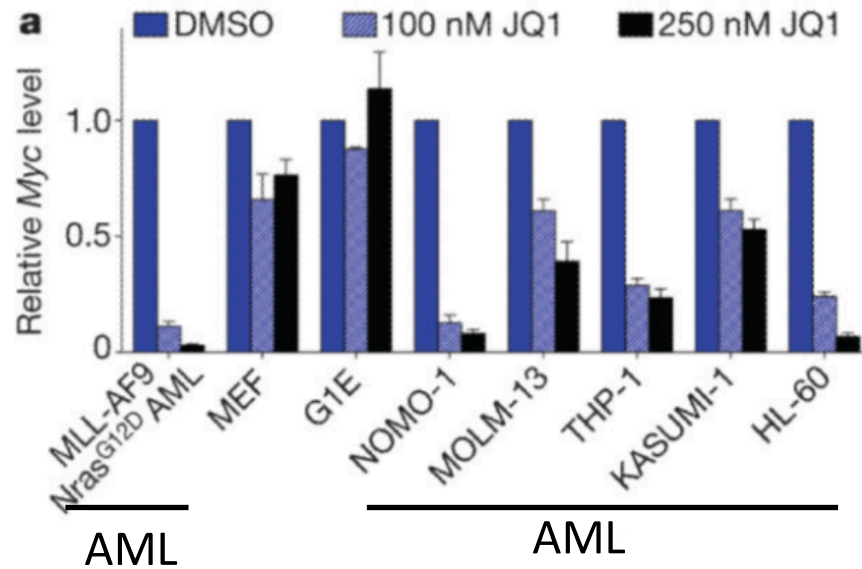

Myc is a transcription factor required for cancer cell proliferation

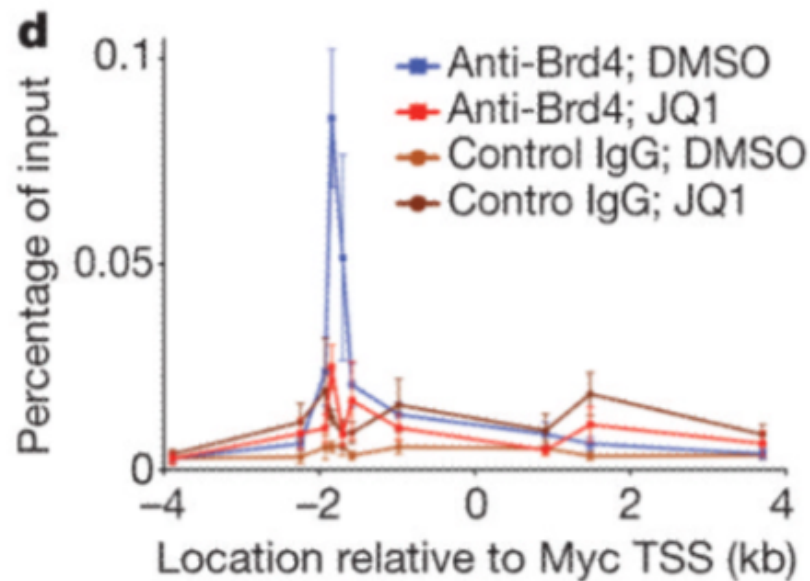

Anti-BRD4 ChIP reveals a hot-spot for Brd4 at ca 2kb upstream of the myc promoter

ACUTE MYELOMA: A LINK BETWEEN BRD4, THE MEDIATOR COMPLEX AND ENHANCERS

Enhancers and Super-enhancers

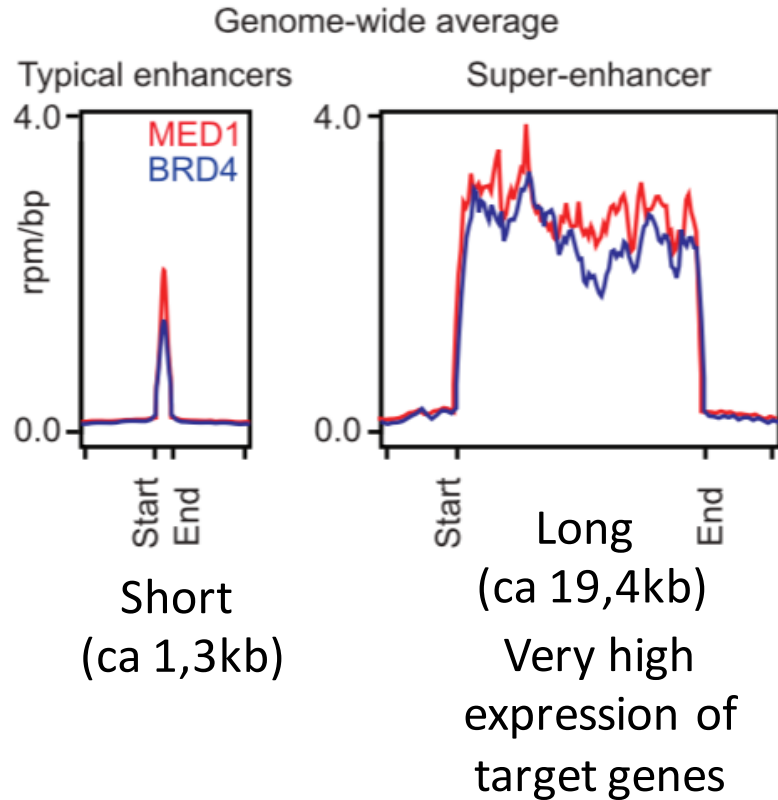

Also Myc is controlled by a super enhancer!!

MED1 is a Mediator complex component: MED1 and BRD4 signal at 308 enhancers (of a total of 8000) was significantly greater than at all other enhancers and promoters. Remarkably, 40% of all enhancer-bound Mediator and BRD4 occupied these 308 super-enhancers.

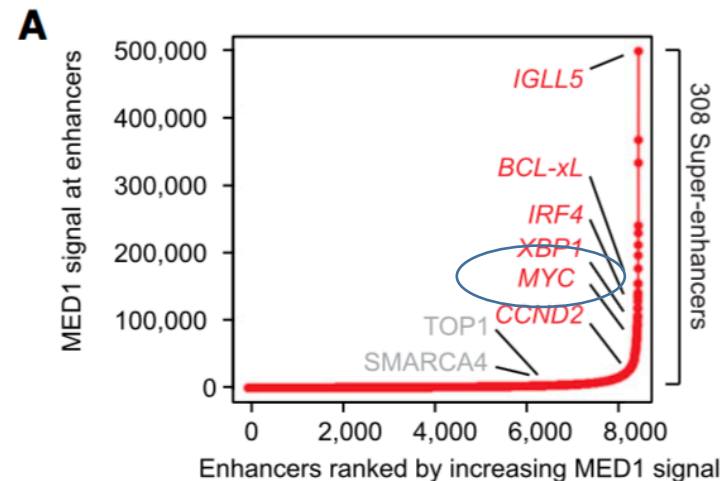

EPIGENETIC REGULATION OF ENHANCERS

BRD4 controls gene expression via 2 major pathways

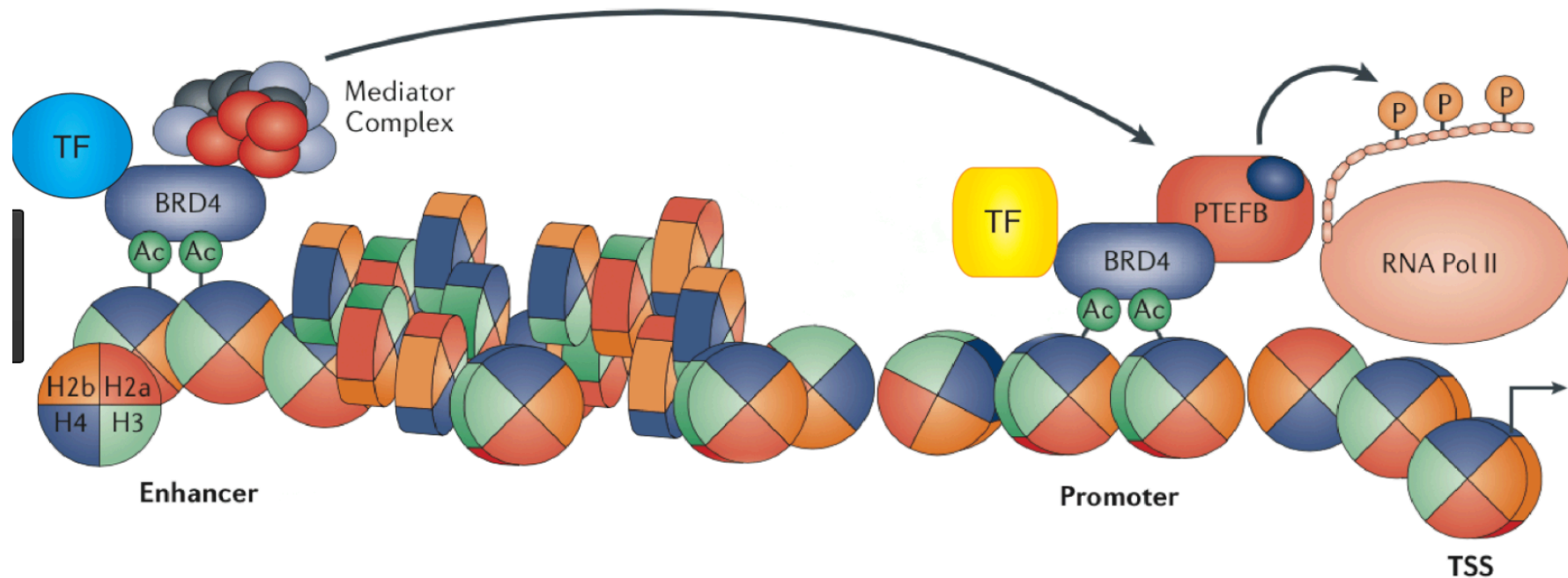

**Enhancer regulation
via the mediator
complex**

**Regulation of processivity
of RNA Polymerase II**

EPIGENIC REGULATION OF ENHANCER ELEMENTS IN VERTEBRATES

In genetics, an enhancer is a short (50–1500 bp) region of DNA that can be bound by proteins (activators) to strongly increase the transcription of a particular gene. These proteins are usually referred to as transcription factors. Enhancers are cis-acting. They can be located up to 1 Mbp (1,000,000 bp) away from the gene, upstream or downstream from the start site. They are found in both prokaryotes (UAS) and eukaryotes.

Human Genome: 400.000 enhancers

Distal cis-regulatory elements of transcription, such as enhancers, were first discovered in the simian virus SV40 genome in the early 1980s [6]. The inclusion of a 72bp SV40 DNA fragment upstream of the β -globin gene reporter increased its expression by 200-fold. Moreover, it was noticed that the viral enhancer remained active when placed in both sense and antisense orientation as well as upstream and downstream of the β -globin gene, thereby laying the foundation of basic enhancer features. Although it was found that the SV40 enhancer could influence the expression of β -globin over a distance of 10 kb, most enhancers in lower eukaryotes such as yeast were located within 100 – 200 bp from their target promoters [7]. Nevertheless, it seems that enhancers evolved their ability to mediate a long-range action in concomitance with the genome expansion of higher eukaryotes. Indeed, studies in drosophila and human cells have revealed that most enhancers are on average located at > 50 Kb away from their target regions [4,8]. For instance, it was shown in leukemia cells that Myc expression is regulated by a group of five enhancers located 1.7 Mb downstream of the proto-oncogene [9]. Recent development of high-throughput sequencing technologies in combination with techniques to probe the three-dimensional structure of the genome allowed the precise genome-wide mapping of enhancers and the initiation of global assessment of their functions and disease-related alterations.

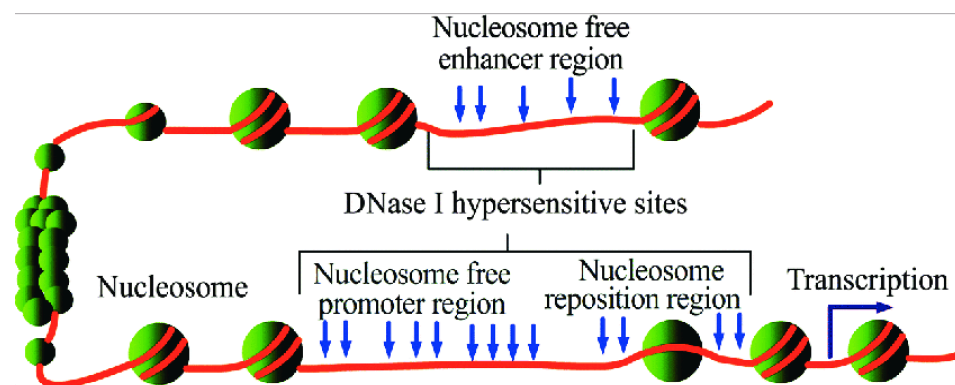

VERTEBRATE ENHANCERS:

- → frequently bound by histone variants: H3.3 and H2A.Z
- → ca 50 – 1500 nt
- → form loop structures stabilized by cohesin
- → **DNase Hypersensitivity** (factors bind; Nucleosome free areas (nucleosome remodellers)
- → → **Enhancers have a special chromatin structure (identified by ChIP seq on enhancer elements)**

EPIGENIC REGULATION OF ENHANCER ELEMENTS IN VERTEBRATES

- The mediator complex (<20 protein subunits) communicates between promoter and enhancer elements (interconnects transcription factors)
- **Essential for transcriptional activation**

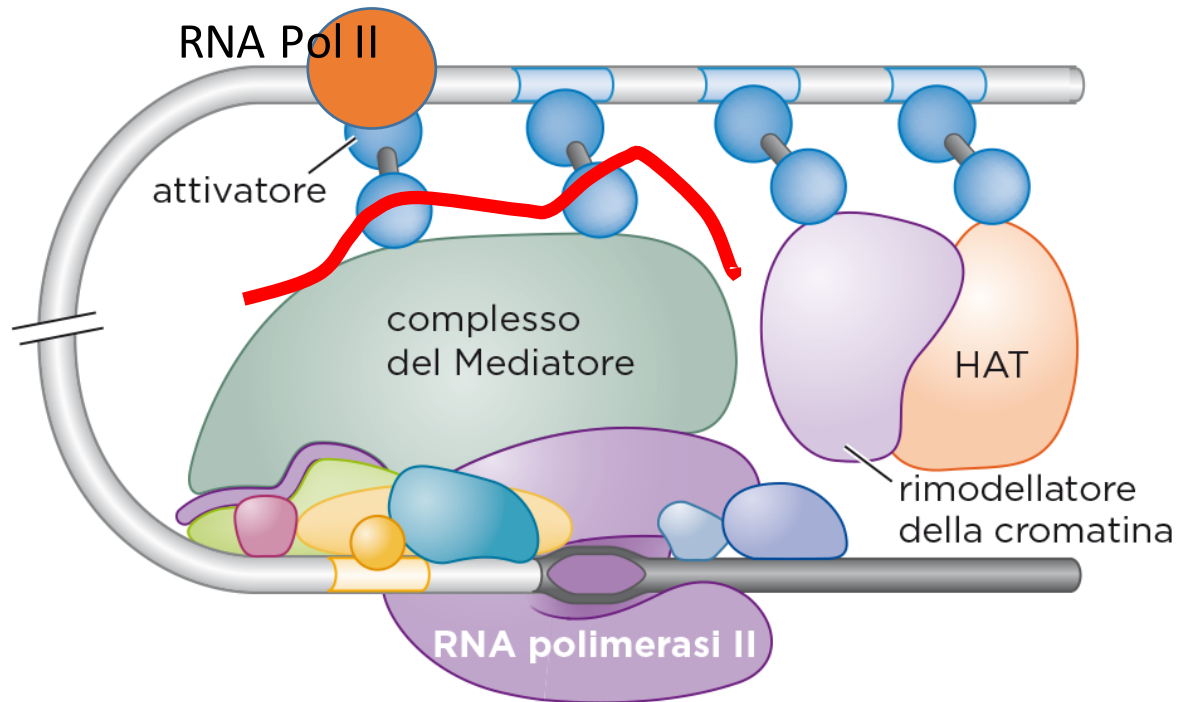

1. Active Enhancer contains binding elements for 2 types of transcription factors

- pioneering TF: able to bind DNA as first TF
- DNA-binding active signaling effectors: final target in a signalling pathway; for example SMAD proteins that get phosphorylated by Nodal/Activin signalling

2. Enhancers are typically associated with p300 HAT

EPIGENETIC REGULATION OF ENHANCER ELEMENTS IN VERTEBRATES

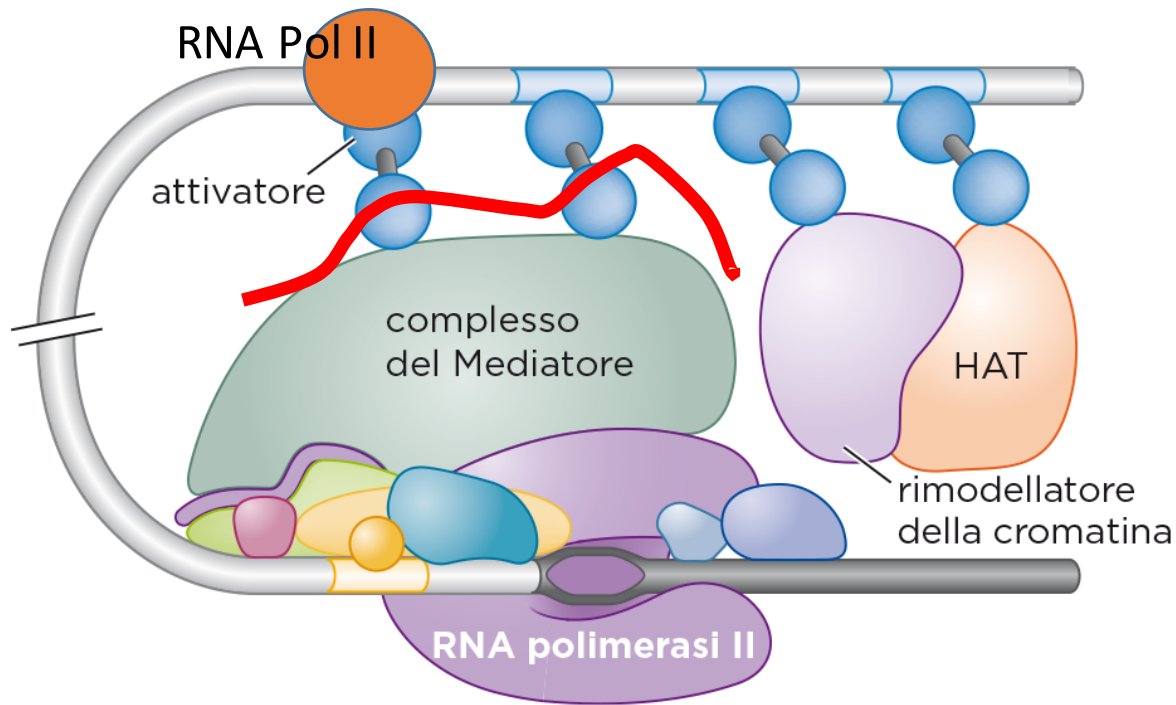

3. Active enhancers are transcribed to produce ncRNAs by RNA Pol II

4. Loop Formation Brings Enhancer Elements To Promoter

→ Efficient Activation Of Transcription
→ Loop Is Formed By Cohesin Proteins

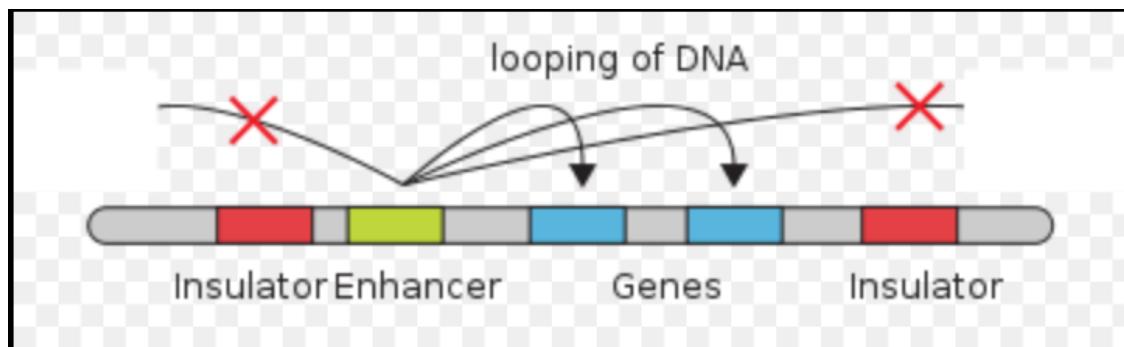

5. Insulators are DNA elements bound by proteins that control which enhancer can engage with a particular enhancer

(see CTCF in Igf2 locus)

EPIGENETIC REGULATION OF ENHANCER ELEMENTS IN VERTEBRATES

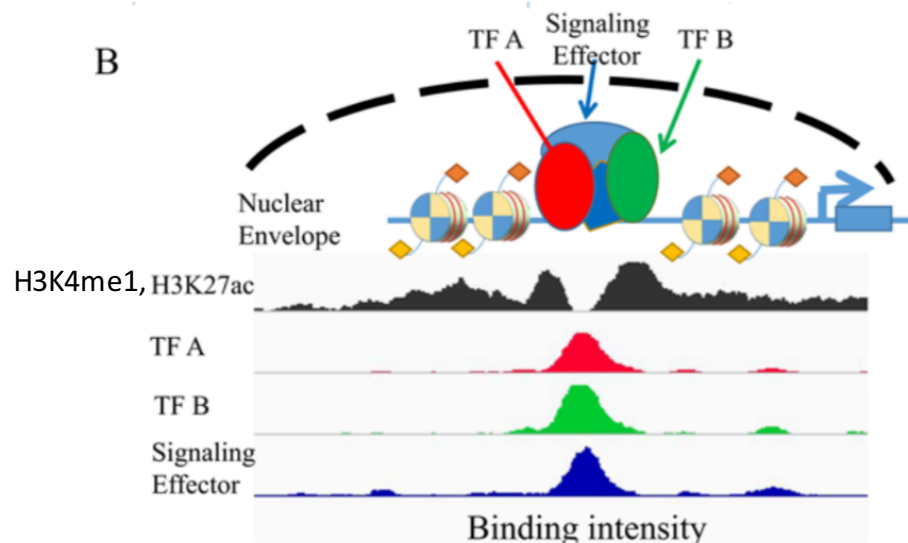

6. Active Enhancers can be identified by an epigenetic code: H3K27ac, H3K4me1, p300

Pioneering transcription factors; co-factors

Transcription factor at end point of signalling pathway

Figure 1. Enhancers act as regulatory hubs in gene activation

(A) Gene activation requires the co-ordinated actions of multiple factors and processes. One of the key processes involved is the cognate enhancer–promoter interaction mediated by TFs and many other cofactors, including mediator/cohesin complexes and chromatin regulators. Transcribed enhancer RNAs (eRNAs) from active enhancers in turn regulate different stages of transcription, including enhancer–promoter looping and the release of paused RNAPII. Typically, gene transcription is associated with distinct chromatin structures, such as the enrichment of histone H3 lysine 27 acetylation (H3K27ac) and histone H3 lysine 4 monomethylation (H3K4me1) at enhancers, histone H3 lysine 4 trimethylation (H3K4me3) at promoters and histone H3 lysine 36 trimethylation (H3K36me3) at gene bodies. (B) Clusters of TF binding sites (TFBSs) at enhancers, including super-enhancers, serve as regulatory hubs to synthesize information from multiple sources of stimuli. Biologically important TFs, including signalling terminal effectors, often associate with each other and bind to (super-)enhancers. Super-enhancers tend to show stronger enhancer activity than typical enhancers.

EPIGENETIC REGULATION OF ENHANCER ELEMENTS IN VERTEBRATES

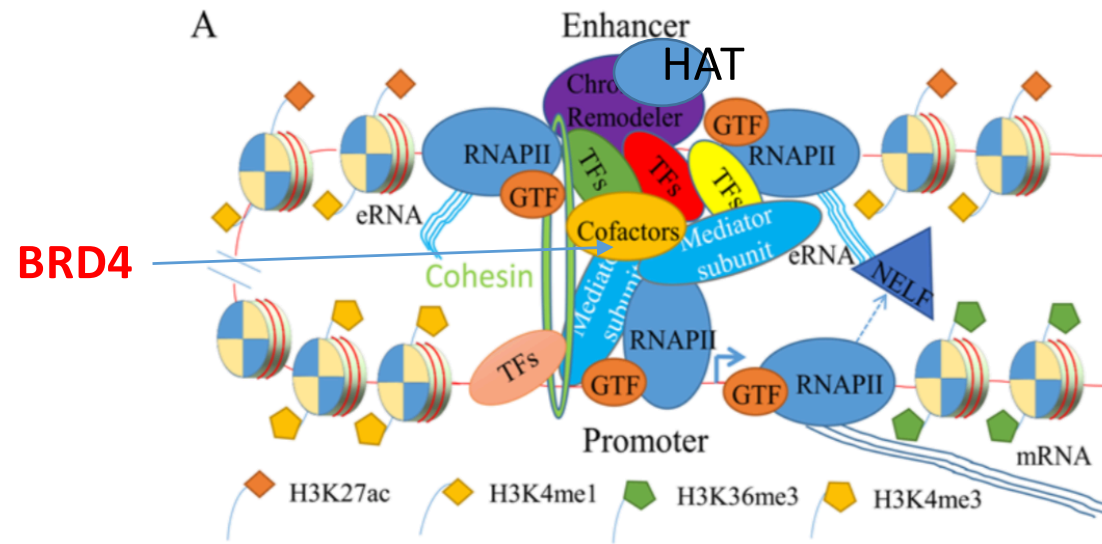

Figure 1. Enhancers act as regulatory hubs in gene activation

(A) Gene activation requires the co-ordinated actions of multiple factors and processes. One of the key processes involved is the cognate enhancer–promoter interaction mediated by TFs and many other cofactors, including mediator/cohesin complexes and chromatin regulators. Transcribed enhancer RNAs (eRNAs) from active enhancers in turn regulate different stages of transcription, including enhancer–promoter looping and the release of paused RNAPII. Typically, gene transcription is associated with distinct chromatin structures, such as the enrichment of histone H3 lysine 27 acetylation (H3K27ac) and histone H3 lysine 4 monomethylation (H3K4me1) at enhancers, histone H3 lysine 4 trimethylation (H3K4me3) at promoters and histone H3 lysine 36 trimethylation (H3K36me3) at gene bodies. (B) Clusters of TF binding sites (TFBSs) at enhancers, including super-enhancers, serve as regulatory hubs to synthesize information from multiple sources of stimuli. Biologically important TFs, including signalling terminal effectors, often associate with each other and bind to (super-)enhancers. Super-enhancers tend to show stronger enhancer activity than typical enhancers.

EPIGENIC REGULATION OF ENHANCER ELEMENTS IN VERTEBRATES

Enhancer elements can be identified by epigenomic profiling: p300, H3K4me1, H3K27me3

**Paper: human embryonic stem cells:
epigenomic profiling by ChIP:**

Epigenetic regulators

p300 HAT

BRG1 ATP-dependent chromatin remodeler also called SMARCA4 ,

Histone modifications that distinguish promoters from distal elements:

H3K4me1, H3K27Ac, H3K27me3

Model system:

Differentiation of hESCs to Neuronal progenitors in vitro
Map epigenetic changes at enhancers of genes that are important for hESC pluripotency and other genes that are important for NP differentiation

Why? Activity of enhancers is expected to change → how do epigenetic signatures change?

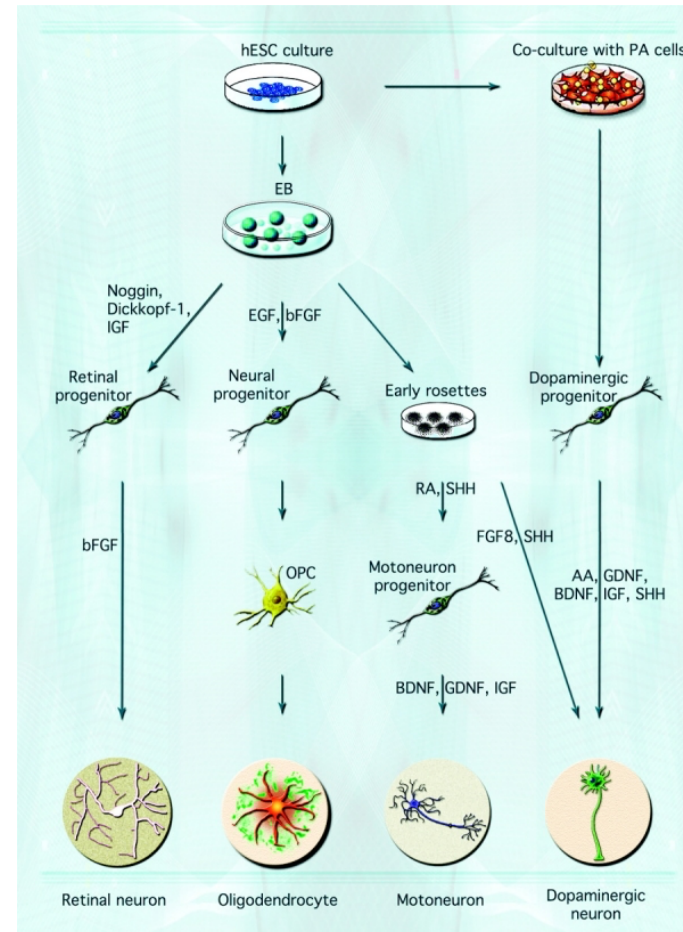

In vitro differentiation of hESCs to neuronal cells can be controlled by Growth/differentiation markers and/or TFs

BRG1: The protein encoded by this gene is a member of the SWI/SNF family of proteins and is similar to the brahma protein of *Drosophila*. Members of this family have helicase and ATPase activities and are thought to regulate transcription of certain genes by altering the chromatin structure around those genes. The encoded protein is part of the large ATP-dependent chromatin remodeling complex SWI/SNF, which is required for transcriptional activation of genes normally repressed by chromatin.

EPIGENETIC REGULATION OF ENHANCER ELEMENTS IN VERTEBRATES

2 Classes of enhancers were identified in **pluripotent hESCs** that show different epigenetic signatures

CLASS I

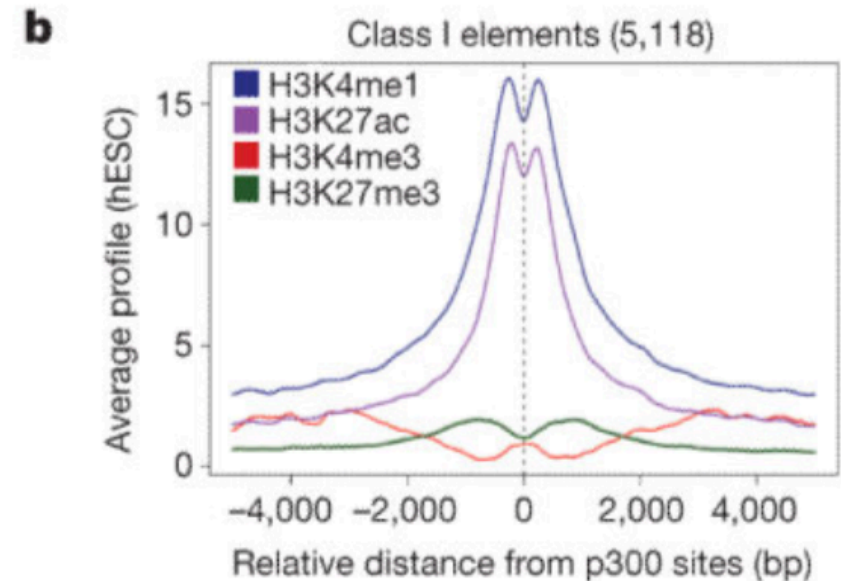
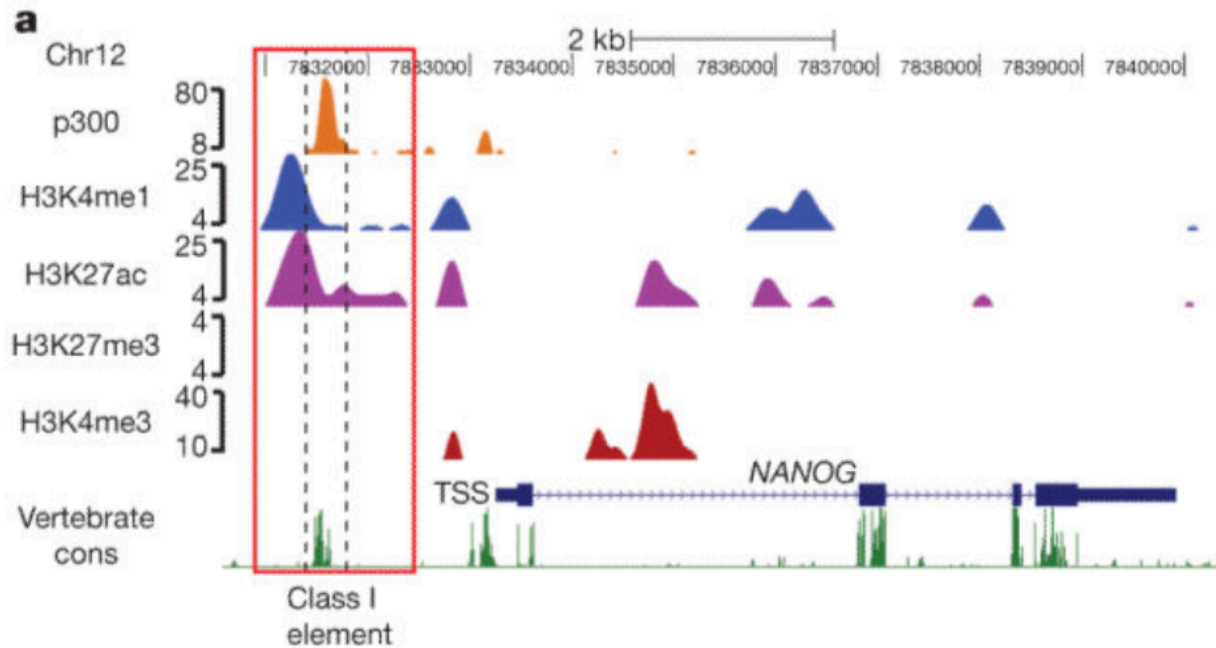

H3K4me1 high
 H3K27Ac high
 p300 (X-axis "0")
 BRG1 high
 No H3K4me3
 No H3K27me3
 Nucleosome depleted

At Enhancers of genes that are essential for hESC: i.e pluripotency defining TFs:
 → example: Nanog enhancer: Nanog is a TF that is essential for hESC pluripotency and is **highly expressed** in hESCs

EPIGENETIC REGULATION OF ENHANCER ELEMENTS IN VERTEBRATES

2 Classes of enhancers were identified in **pluripotent hESCs** that show different epigenetic signatures

CLASS II

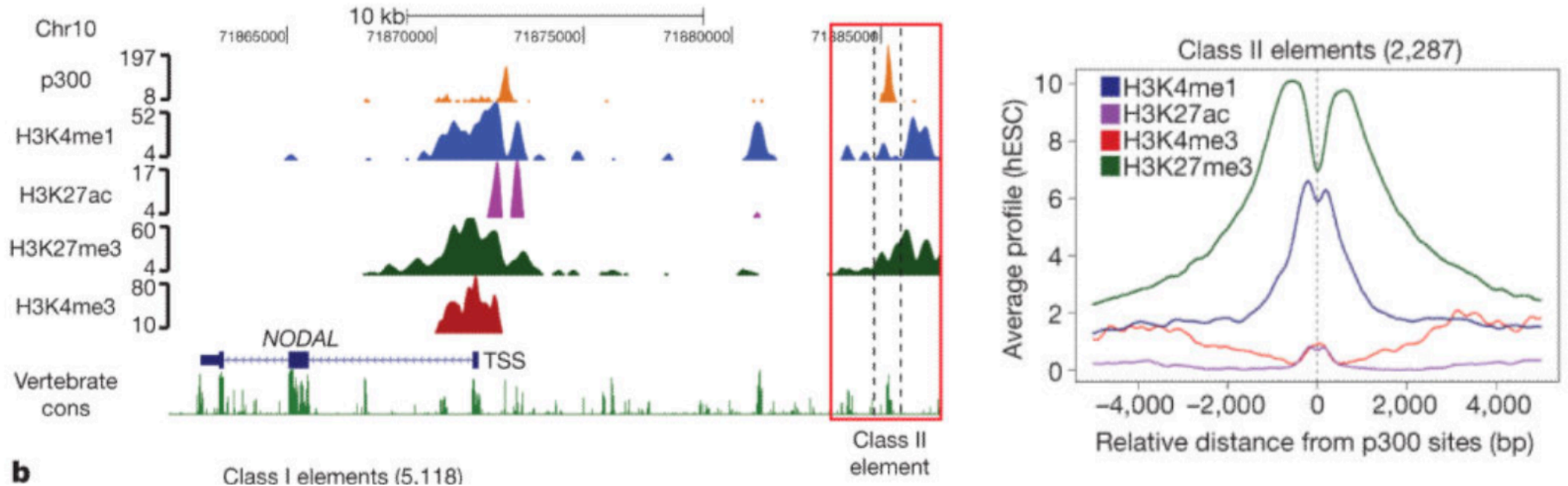

H3K4me1 high
NO H3K27Ac
 p300 (X axis "0")
 BRG1 high
 No H3K4me3
H3K27me3 high
 Nucleosome depleted

At Enhancers of genes that are essential for early differentiation but not expressed in hESCs. They are however needed for the first differentiation steps.
 → example: NODAL enhancer; Nodal signaling give rise to ectoderm and mesoderm, neuroectoderm formation

EPIGENETIC REGULATION OF ENHANCER ELEMENTS IN VERTEBRATES

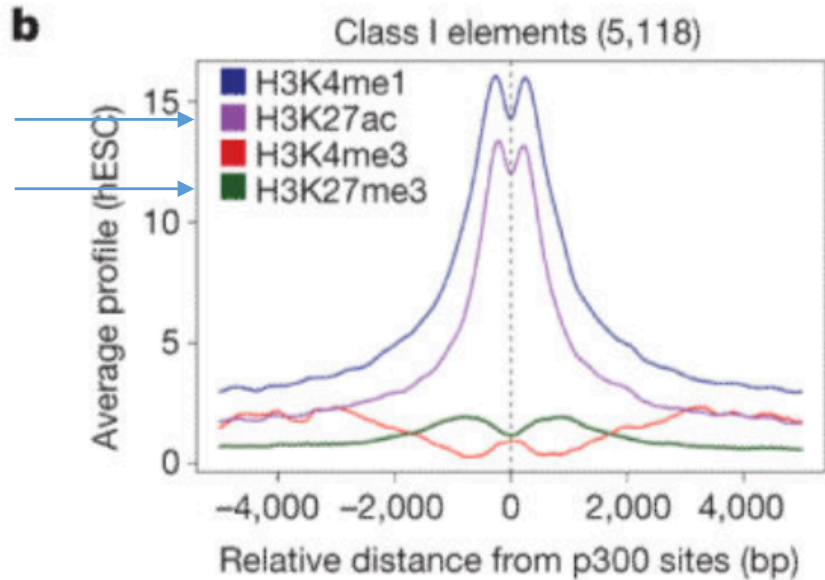

Active enhancer
 → gene expressed (RNA seq)
 RNA Pol II: YES
 Polycomb: LOW

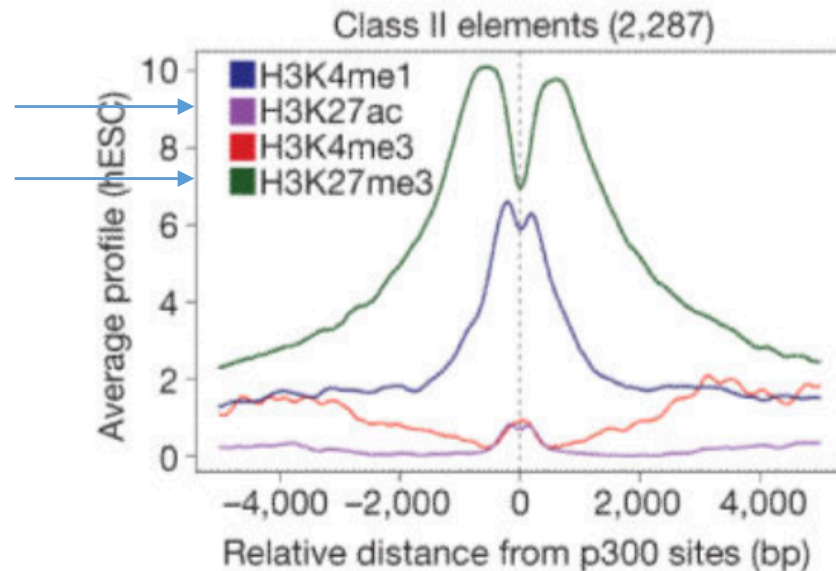

Poised enhancer
 → gene poorly expressed (RNA seq)
 RNA Pol II: LOW
 Polycomb: YES

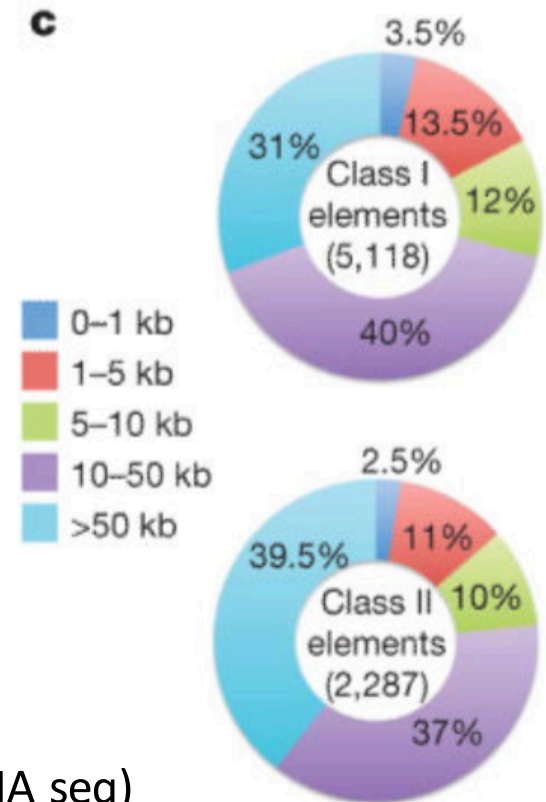

Distance to TSS: class I and class II show same distribution

EPIGENIC REGULATION OF ENHANCER ELEMENTS IN VERTEBRATES

HOW DOES EPIGENETIC SIGNATURES CHANGE FROM CLASS II – CLASS I ENHANCERS DURING DIFFERENTIATION?

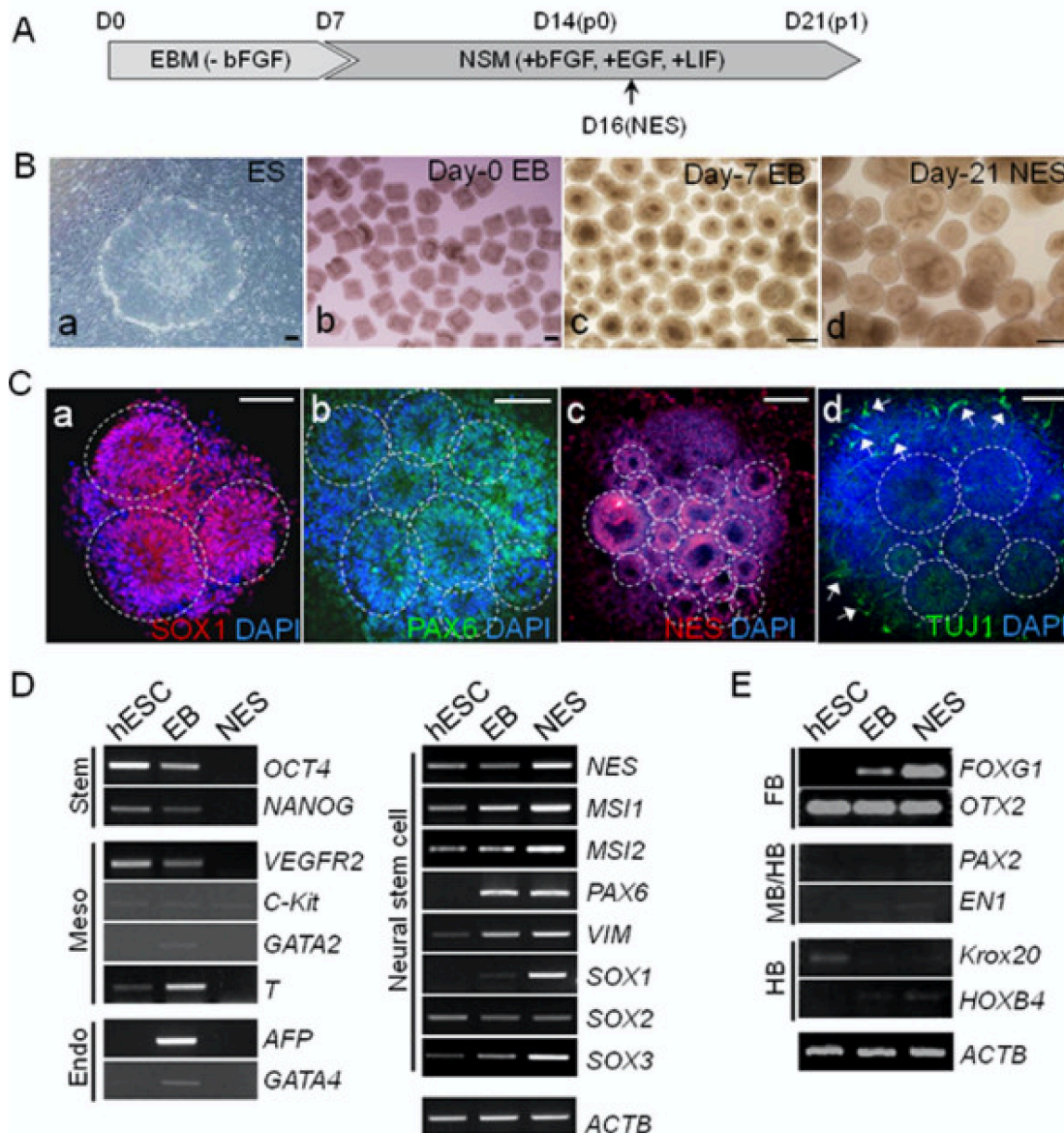

In vitro differentiation of hESCs to neuroectodermal spheres (NES)

Controlled derivation of neuroectodermal spheres from human embryonic stem cells. (A) Schematic showing neuroectodermal sphere (NES). By a simple medium change without an attachment step, embryoid bodies (EBs) could be differentiated to NESs harboring neuroprogenitor cells. EBs were grown in EBM for a week and then transferred to NSM supplemented with growth factors. The first subculture was performed one week later (D14) and, about two days later (D16), rosette-containing NESs appeared. The NES samples we used were D21 NESs, if not otherwise indicated.

(B) Photographs of differentiating cell clumps at indicated times. Human embryonic stem cell (hESC) colonies (a) were divided into regular-sized (500 μm in length) clumps (b) using a chopper. Floating EBs at day 7 (c) are shown. NESs at day 21 have prominent rosette-like folded structures in the spheres (d). We piled up EBs and NESs in single spots before taking pictures.

(C) Expression of neural stem cell (NSC) markers in NESs. NESs were allowed to attach to culture equipment and were stained either for SOX1 (a), PAX6 (b), Nestin (NES, c) and TUJ1 (d). TUJ1-positive neurites are scattered, usually around the boundaries of NES clumps (arrows). Boundaries of rosettes are indicated by dotted circles.

(D) RT-PCR for various marker genes of different cell lineages. NSC marker genes are abundantly transcribed in hESC-derived NESs (right panel). Other lineage markers such as those of ESCs (Stem), mesoderm lineage cells (Meso) and endoderm lineage cells (Endo) are not preferentially expressed in NESs (left panel). β-Actin (ACTB), internal control.

(E) RT-PCR analysis for markers of anterior regional identity (FB; FOXG1 and OTX2), mid-hind brain markers (MB/HB; PAX2 and EN1), and posterior CNS markers (HB; KROX20 and HOXB4). Scale bars, 200 μm in B and 100 μm in C; EBM, embryoid body medium; NSM, neurosphere medium; bFGF, basic fibroblast growth factor; EGF, epidermal growth factor; LIF, leukemia inhibitory factor.

EPIGENETIC REGULATION OF ENHANCER ELEMENTS IN VERTEBRATES

HOW DOES EPIGENETIC SIGNATURES CHANGE FROM CLASS II → CLASS I ENHANCERS DURING DIFFERENTIATION?

Example: ARHGEF17 promoter / enhancer

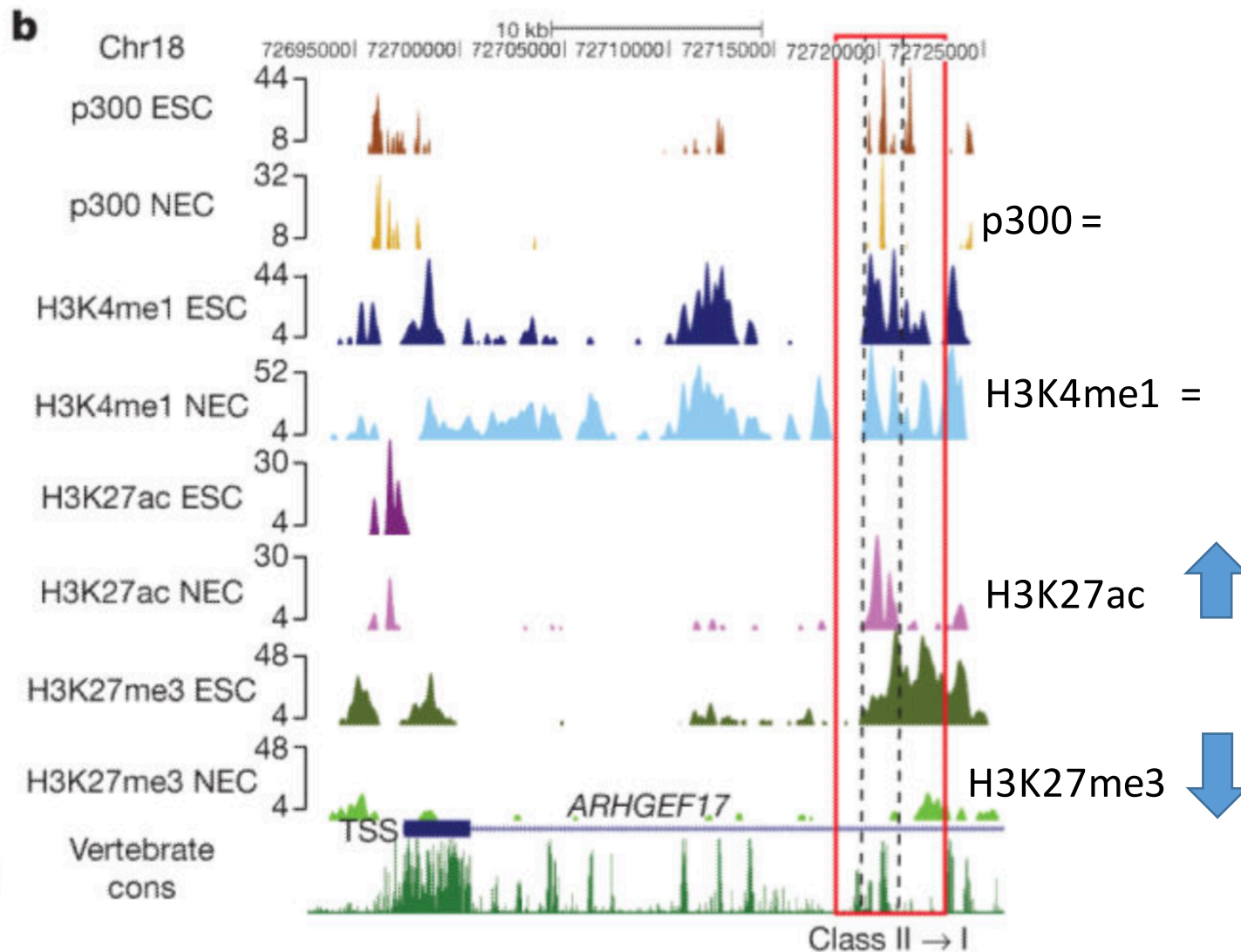

Enhancer of early differentiation genes switch from class II to class I promoters when hESCs are differentiated to neuroectodermal spheres

Enhancer of early differentiation genes switch from class II to class I

b

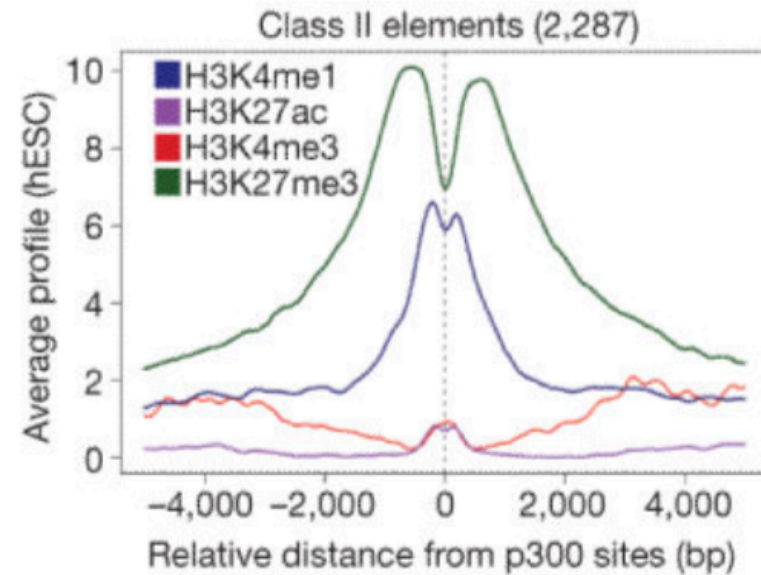
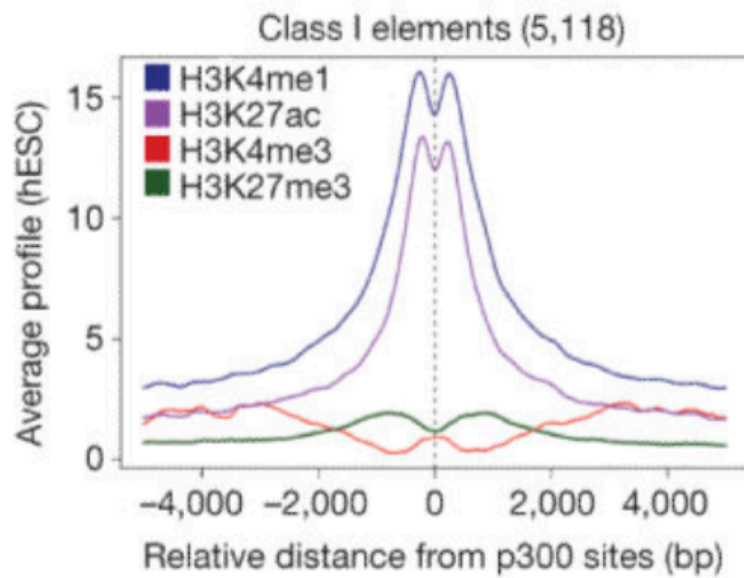

hESC

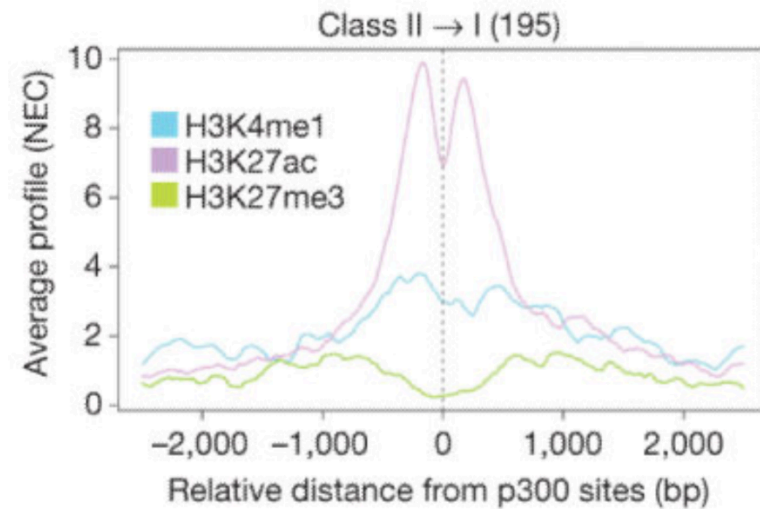

NEC

Epigenetic regulation of enhancer elements in vertebrates

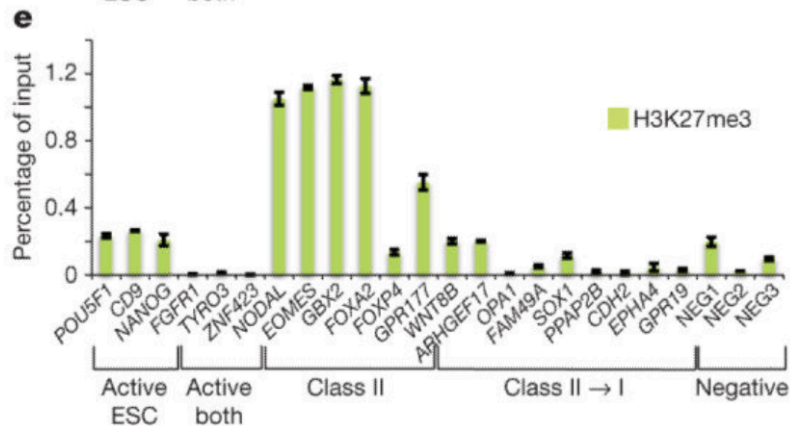
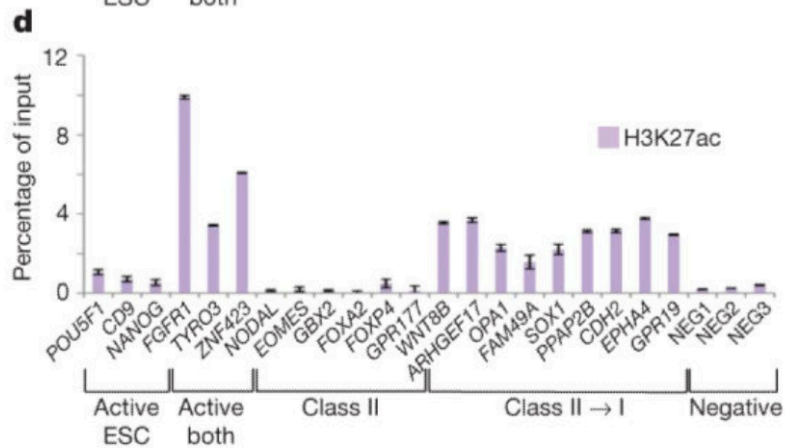
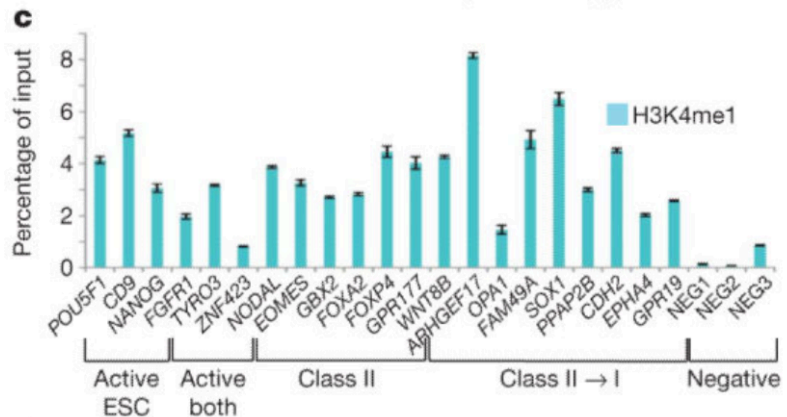

ChIP on Class I and Class II enhancer of indicated genes using human neuroectodermal spheres

H3K4me1: marks all enhancers (together with p300 and BRG1)

H3K27Ac: increased in Class II – Class I enhancers

H3K27me3: strongly increased in poised enhancers and slightly elevated in inactive enhancers (in hESCs)

Epigenetic regulation of enhancer elements in vertebrates

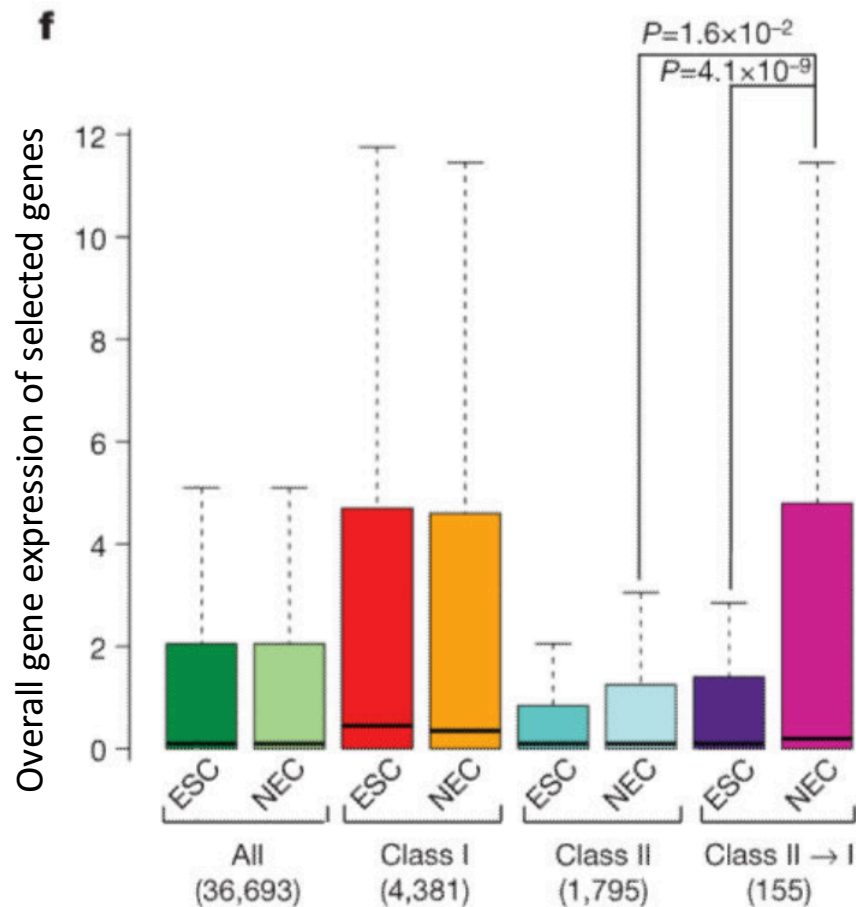

RNA seq on genes regulated by class I and class II enhancers during hESC → NEC (neuroectodermal sphere) differentiation

Genes controlled by enhancers that shift from class II to class I during hESC → NEC differentiation show enhanced expression

Those genes show increased expression in hNEC compared to hESCs

Epigenetic regulation of enhancer elements in vertebrates

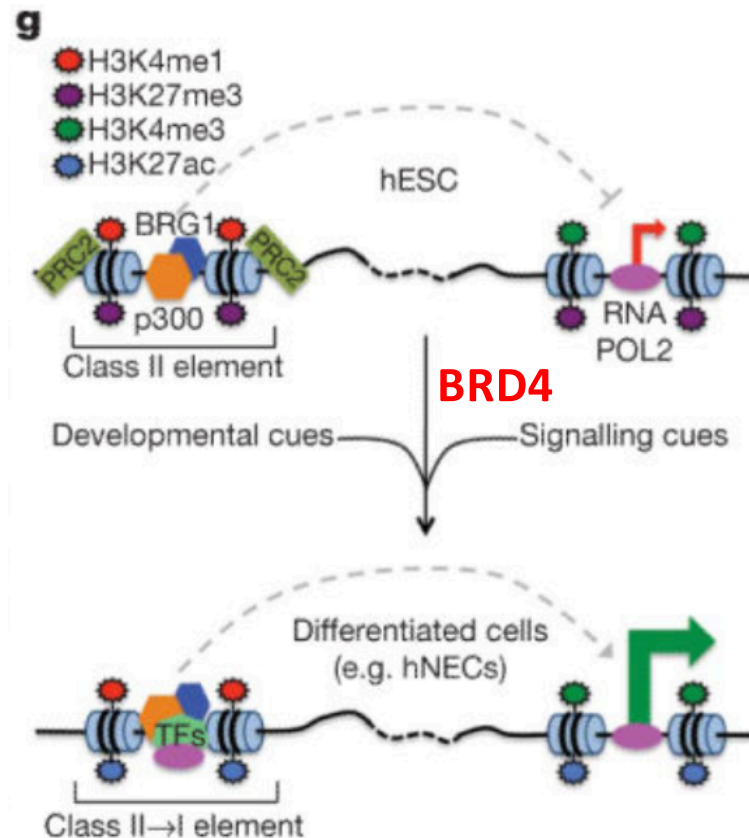

Proposed model for enhancer bookmarking during early embryonic development. Poised developmental enhancers (class II) are marked by a unique chromatin signature, involving occupancy of chromatin modifiers p300, BRG1 and PRC2 and nucleosomal regions marked by H3K4me1 and H3K27me3. During differentiation, appropriate developmental and signalling cues are able to rapidly transition these poised, pre-marked enhancers into an active state represented by the acquisition of H3K27ac, RNA POL2 binding, recruitment of tissue-specific transcription factors (TFs) and loss of H3K27me3, leading to the establishment of tissue-specific gene expression patterns.

EPIGENETIC REGULATION OF ENHANCER ELEMENTS IN VERTEBRATES

What happens at intermediate stage?
POISED PROMOTERS: semi-active; pioneering transcription factors present; waiting to receive trigger for activation

- Transcription factor as endpoint of signalling event
- RNA Pol II recruitment
- Production of ncRNA = eRNA

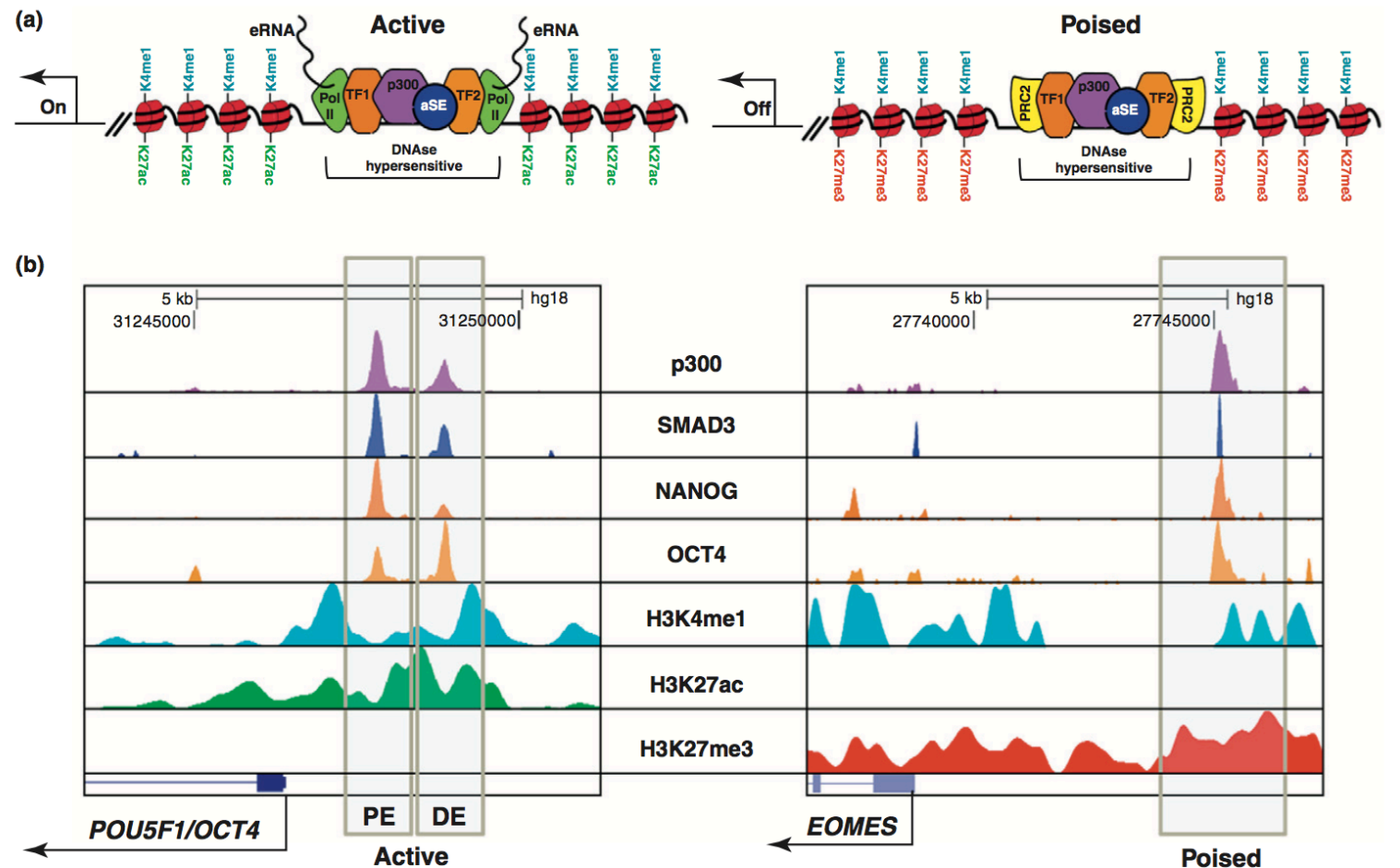

TRENDS in Genetics

Figure 1. Chromatin properties at active and poised enhancers. **(a)** Schematic representation of proteins, histone modifications and RNA found at active (i) and poised (ii) enhancers. An active, but not poised, enhancer has the ability to drive gene expression. At both enhancer classes, multiple transcription factors (TF1 and TF2, orange), DNA-binding active signaling effectors (aSE, blue) and coactivators (p300, purple) occupy the central region of low nucleosomal density, which is hypersensitive to DNase. In addition, active enhancers are bound by RNA-polymerase II (Pol II, light green) which produces bidirectional short RNAs called eRNAs. By contrast, poised enhancers lack Pol II, but, at least in human embryonic stem cells (hESCs), are occupied by the Polycomb repressive complex 2 (PRC2, yellow). The nucleosomes flanking enhancer regions are marked by monomethylation of histone H3 lysine 4 (H3K4me1, light blue). Lysine 27 of histone H3 is commonly acetylated at the nucleosomes flanking active enhancers (H3K27ac, dark green) but methylated at poised enhancers (H3K27me3, red). **(b)** Genome browser representations of select protein and histone modification enrichments at a model loci containing active (*POU5F1/OCT4*, left) and poised (*EOMES*, right) enhancers (box) in hESCs. WIG files from published data [16,80,92] for p300 (coactivator, purple), SMAD3 (active signaling effector, blue), OCT4 (TF, orange), NANOG (TF, orange), H3K4me1 (light blue), H3K27ac (green) and H3K27me3 (red) were generated using QuEST and imported into the UCSC browser. Note the tight overlap of TF (OCT4, NANOG and SMAD3) and p300 binding, and broader regions surrounding the enhancers and showing H3K4me1 enrichments. H3K27ac (green) flanks active enhancers, but is completely absent at the poised enhancer where the same lysine residue is methylated over a broader chromosomal region (red). OCT4 expression is driven by two conserved enhancers, the distal (DE) and the proximal enhancer (PE), with a distinct activity during early embryonic development; both enhancers are active in human embryonic stem cells [9,93,94].

BRD4 is required for Myc expression in AML

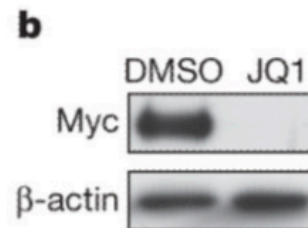
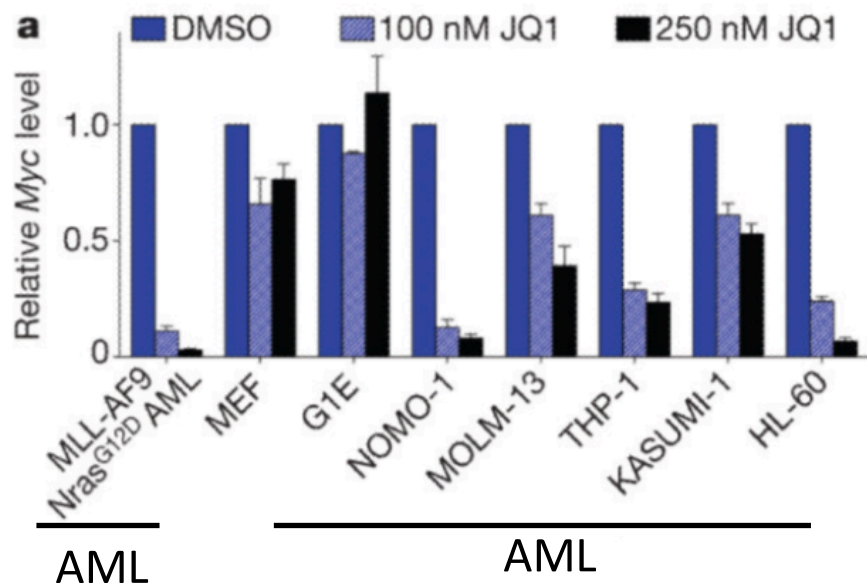

Inhibition of Brd4 reduces Myc expression

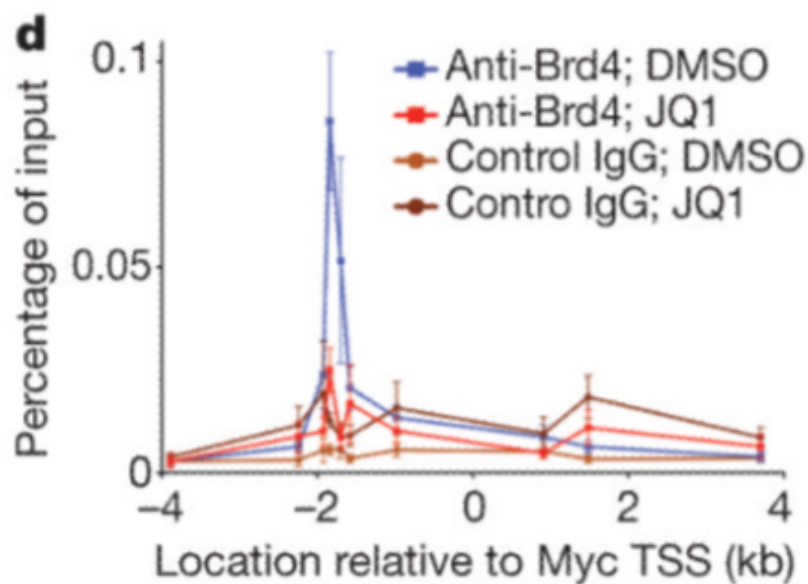

ChIP reveals a hot-spot for Brd4 at ca 2kb upstream of the myc promoter

A LINK BETWEEN BRD4, THE MEDIATOR COMPLEX AND ENHANCERS

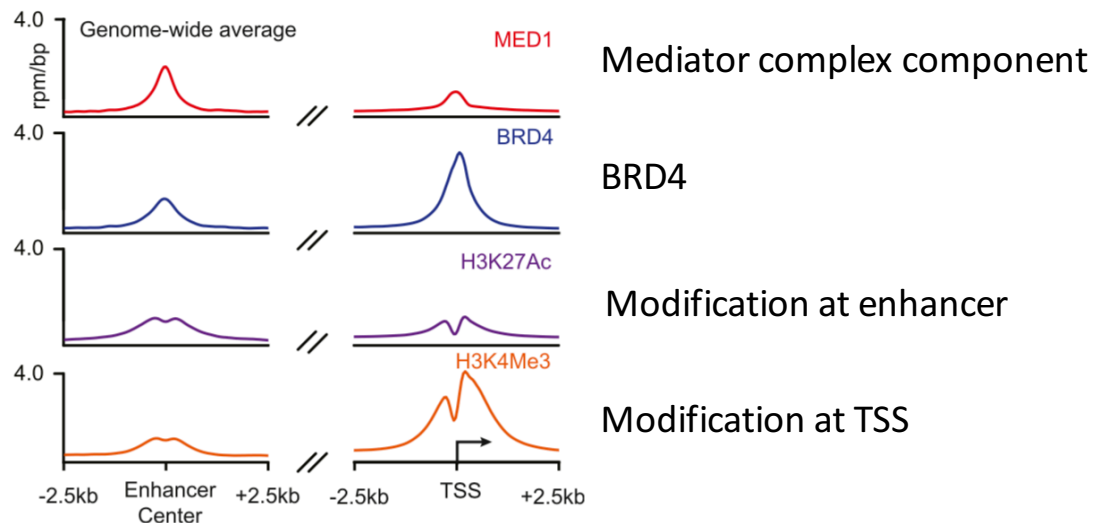
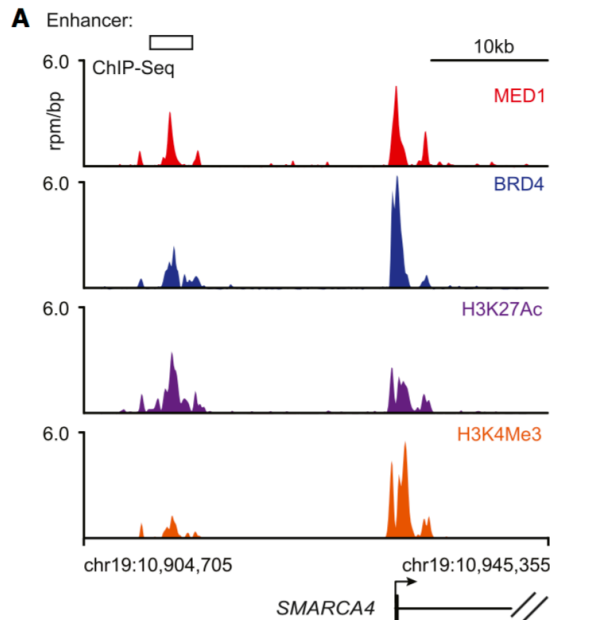

**BRD4 co-occupied enhancers and TSSs with MED1 throughout the genome.
Representative gene: SMARCA4. Levels of BRD4 and MED1 were strongly correlated**

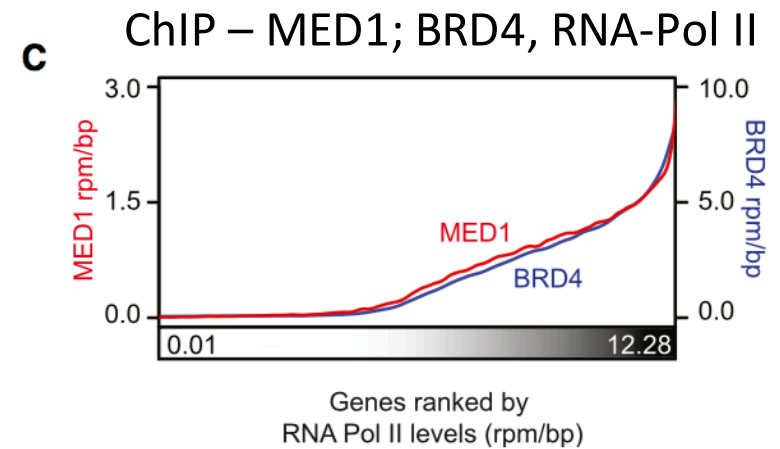

The more MED1/BRD4 – the more RNA Pol II at promoter → more active

ACUTE MYELOMA: A LINK BETWEEN BRD4, THE MEDIATOR COMPLEX AND ENHANCERS

Enhancers and Super-enhancers

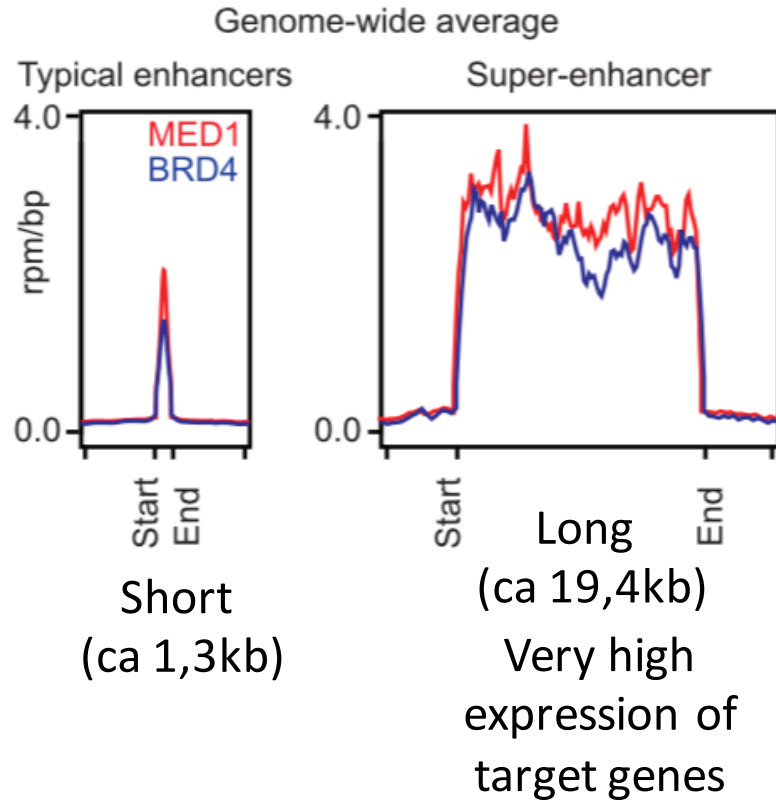

Also Myc is controlled by a super enhancer!!

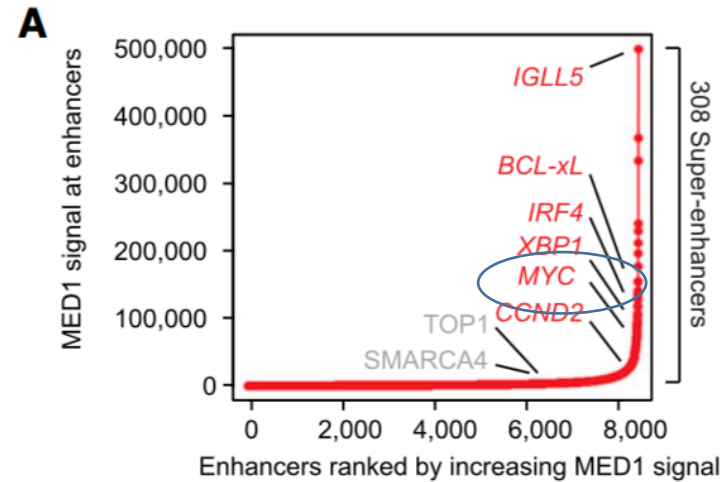

MED1 and BRD4 signal at 308 enhancers (of a total of 8000 was significantly greater than at all other enhancers and promoters. Remarkably, 40% of all enhancer-bound Mediator and BRD4 occupied these 308 super-enhancers.

BRD4 AT SUPER ENHANCERS IN MULTIPLE MYELOMA GENES AND CANCER RELEVANT GENES

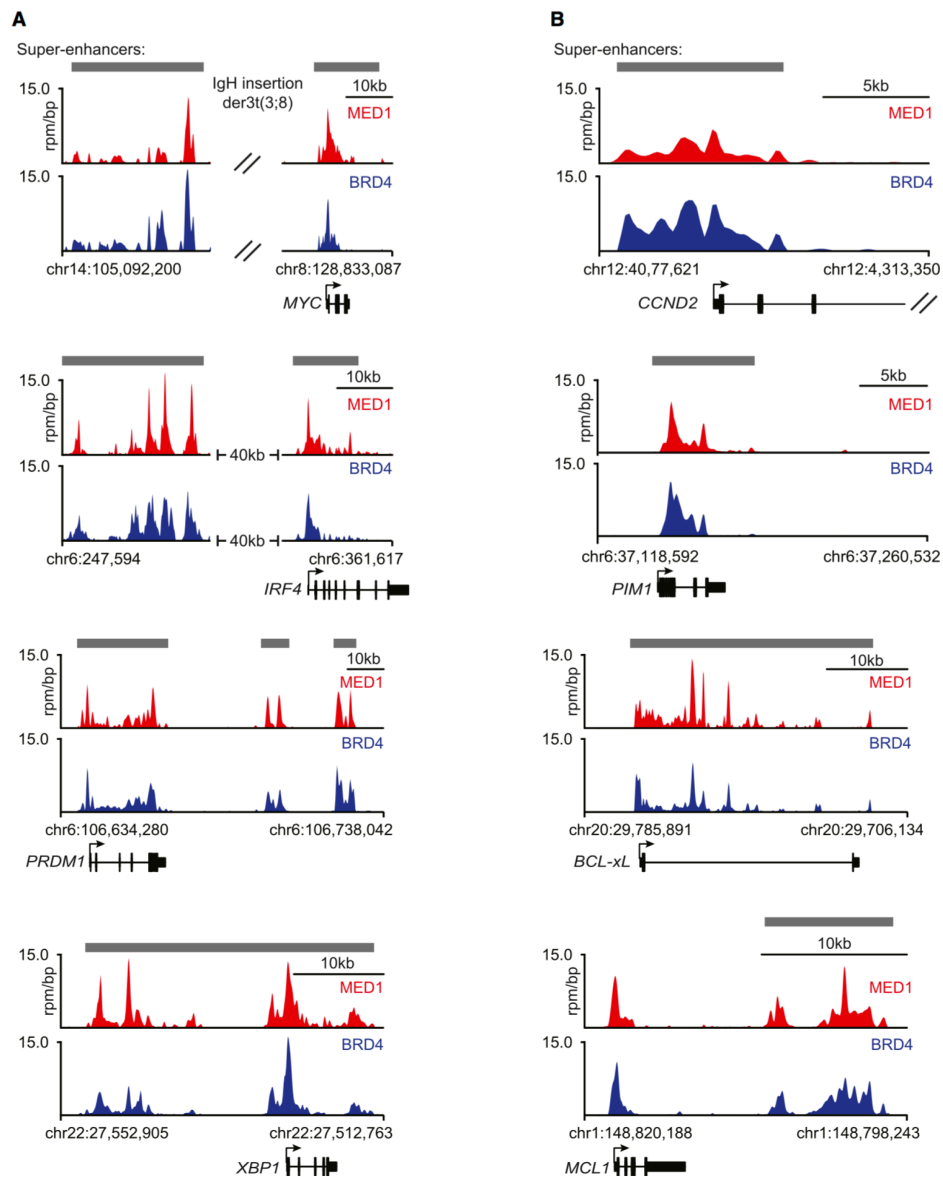

A: Genes with important roles in MM biology
B: Genes with important roles in cancer

(A and B) Gene tracks of MED1 and BRD4 ChIP-seq occupancy at super-enhancers near genes with important roles in MM biology (A) or genes with important roles in cancer (B). Super-enhancers are depicted in gray boxes over the gene tracks. The x axis shows genomic position, and super-enhancer-containing regions are depicted with a gray box. The y axis shows signal of ChIP-seq occupancy in units of rpm/bp.

JQ1 treatments releases Brd4 from chromatin

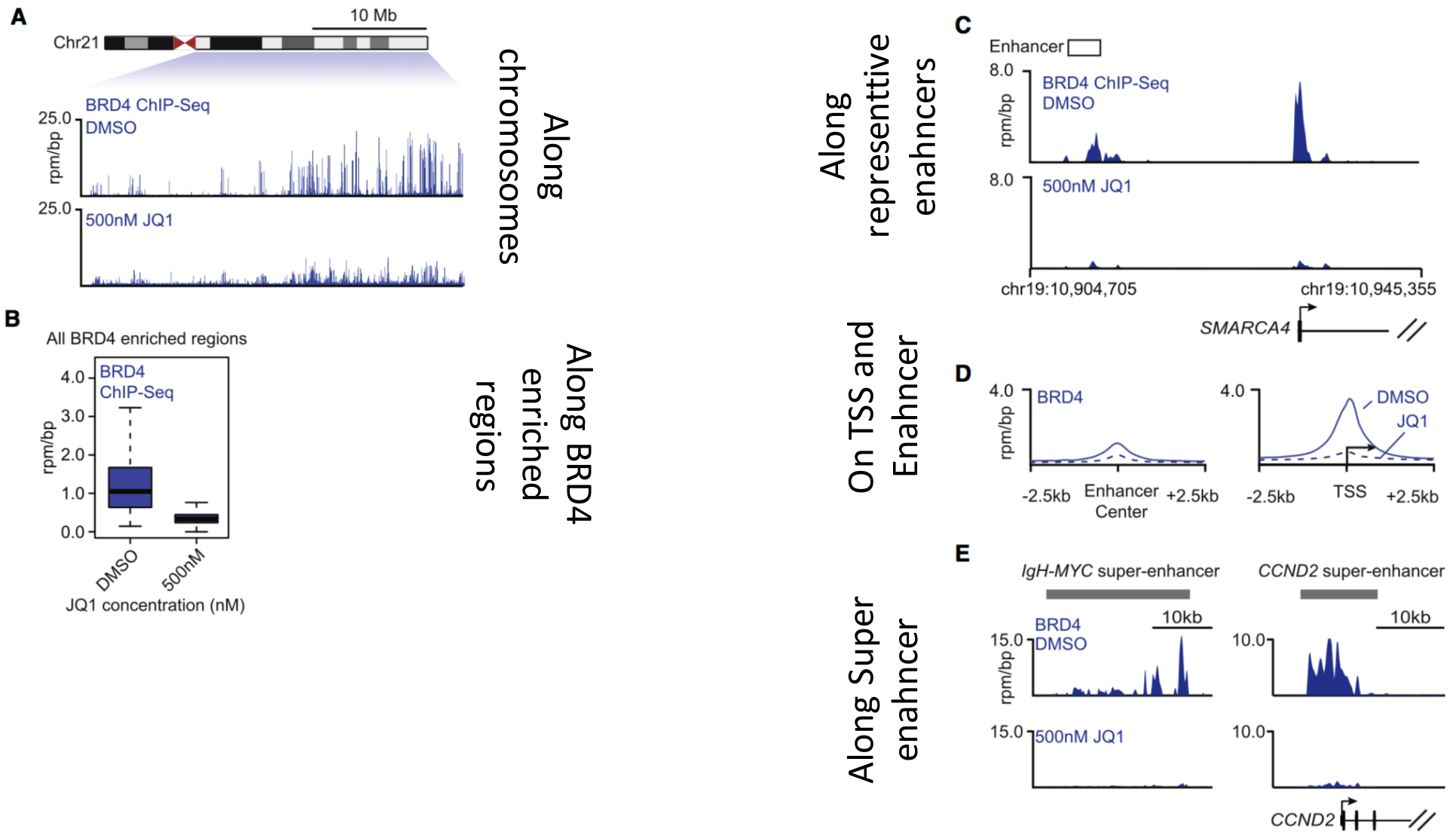

JQ1 treatments affect severely super enhancer function

A

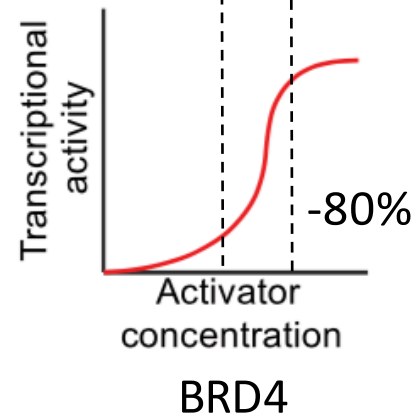
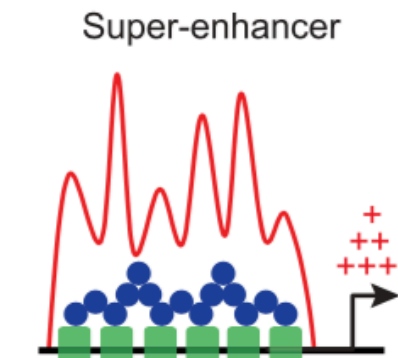
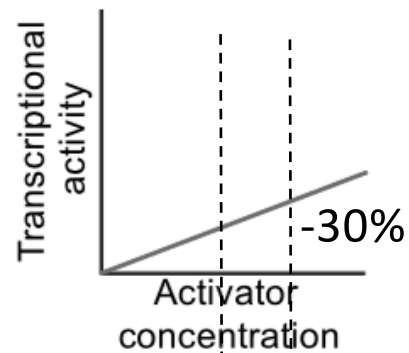
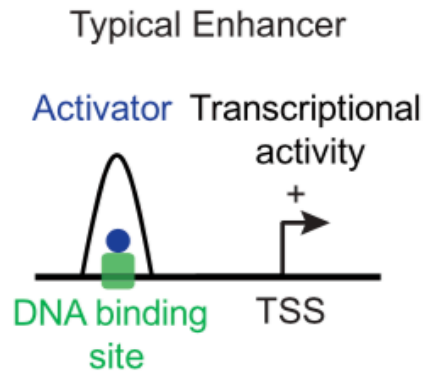

GENERATION OF ENHANCER FUNCTION:

Enhancers are formed through cooperative and synergistic binding of multiple transcription factors and co-activators.

As a consequence of this binding behavior, enhancers bound by many cooperatively interacting factors lose activity more rapidly than enhancers bound by fewer factors when the levels of enhancer-bound factors are reduced.

HYPOTHESES:

The presence of super-enhancers at *MYC* and other key genes associated with Myeloid myeloma led us to consider the hypothesis that super-enhancers are more sensitive to reduced levels of BRD4 than typical enhancers and that genes associated with super-enhancers might then experience a greater reduction of transcription than genes with average enhancers when BRD4 is inhibited.

JQ1 treatments dramatically reduces BRD4 function in MM cells

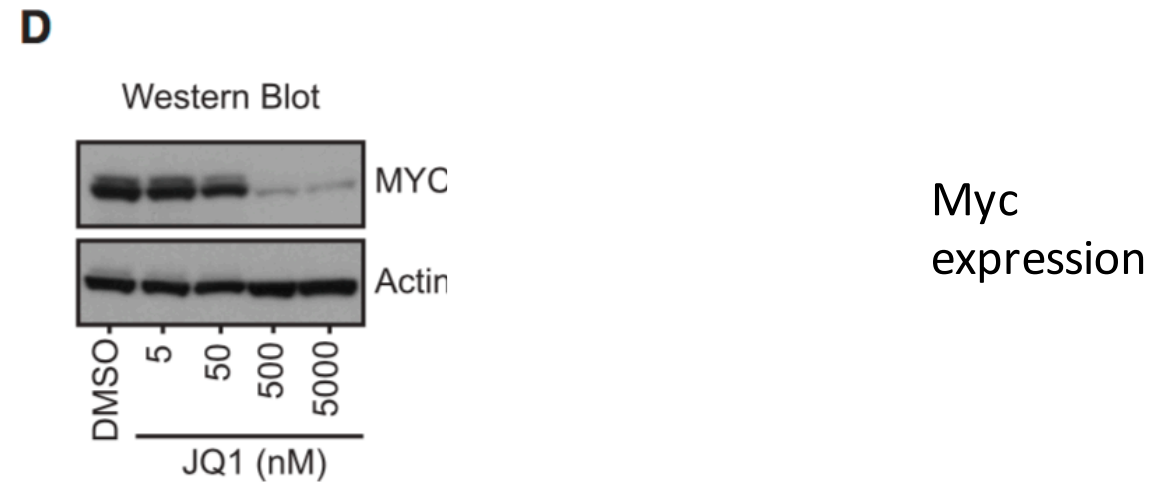
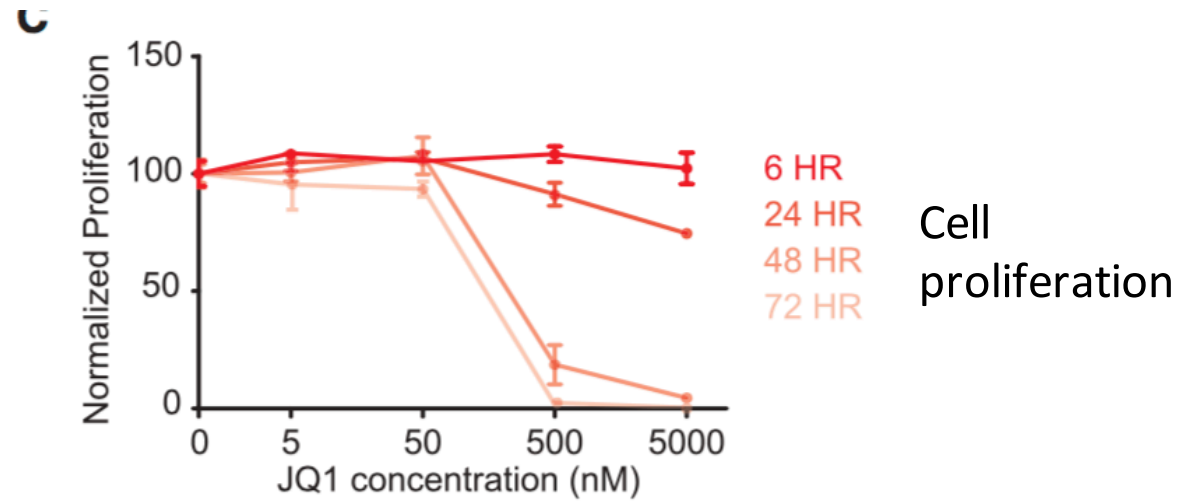
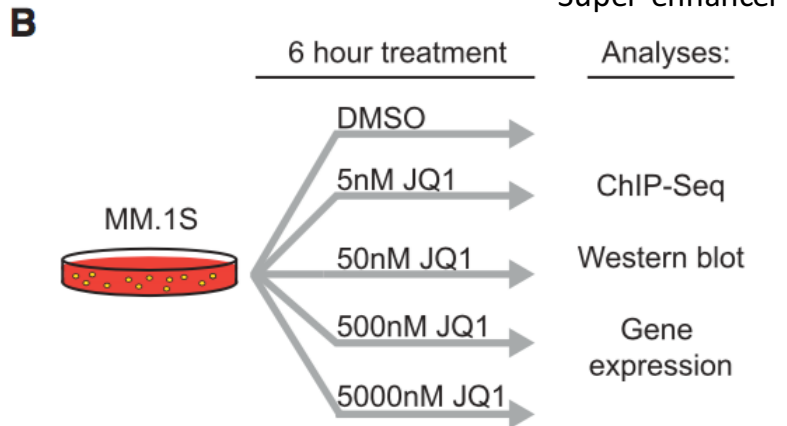

JQ1 treatments dramatically reduces BRD4 function in MM cells

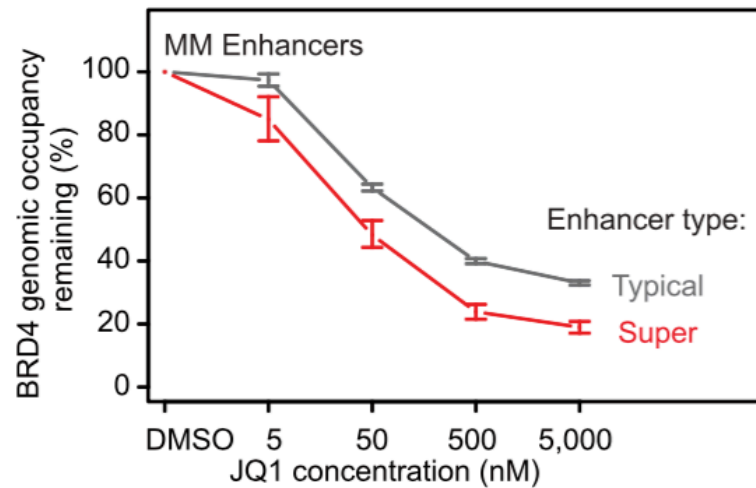

JQ1 mediated loss of BRD4 is more efficient at superenhancers

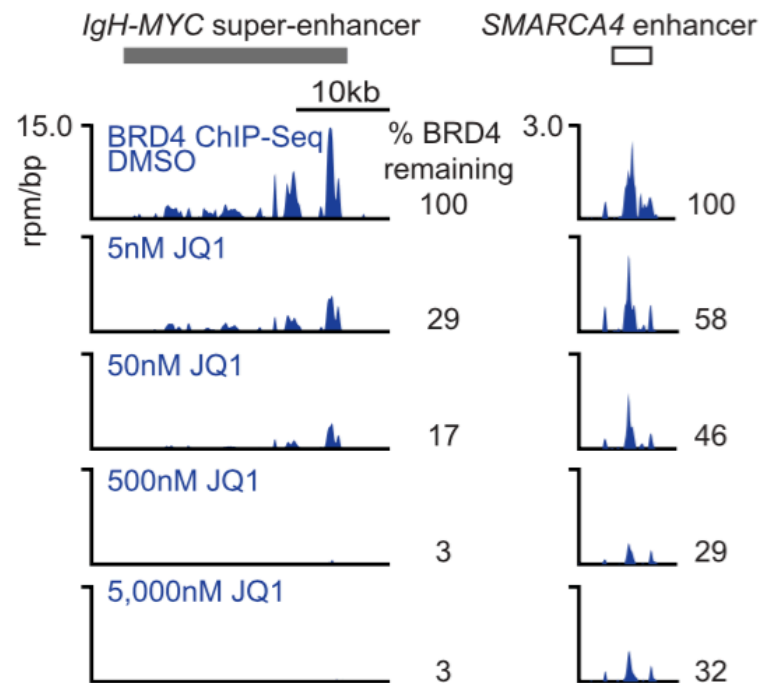

JQ1 mediated loss of BRD4 is more efficient at superenhancers

Examples:
 IgH-MYC superenhancer
 SMARCA4 classic enhancer

Brd4 interacts with the Mediator complex to activate gene expression

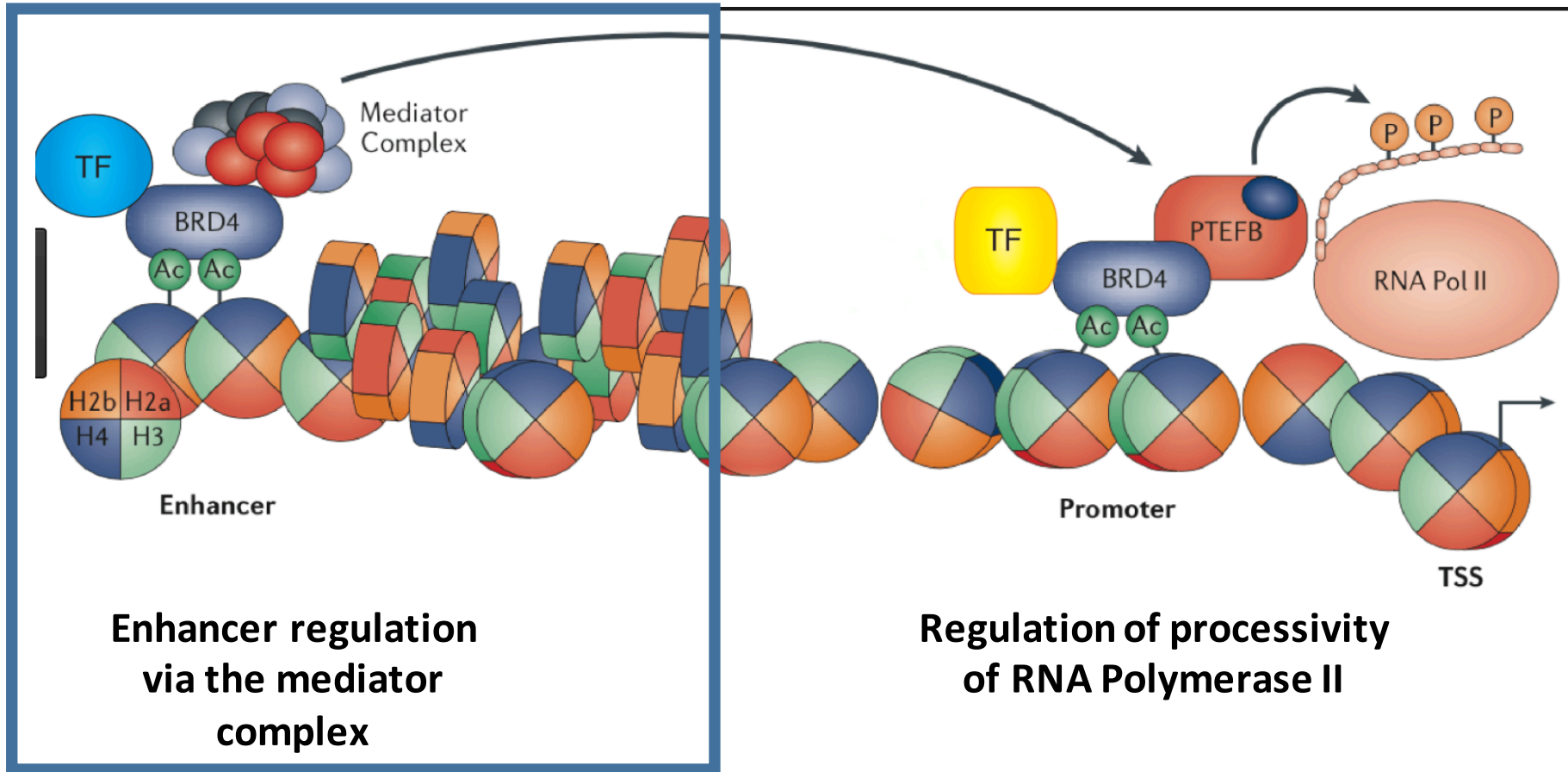

Brd4 interacts with the Mediator complex to activate gene expression

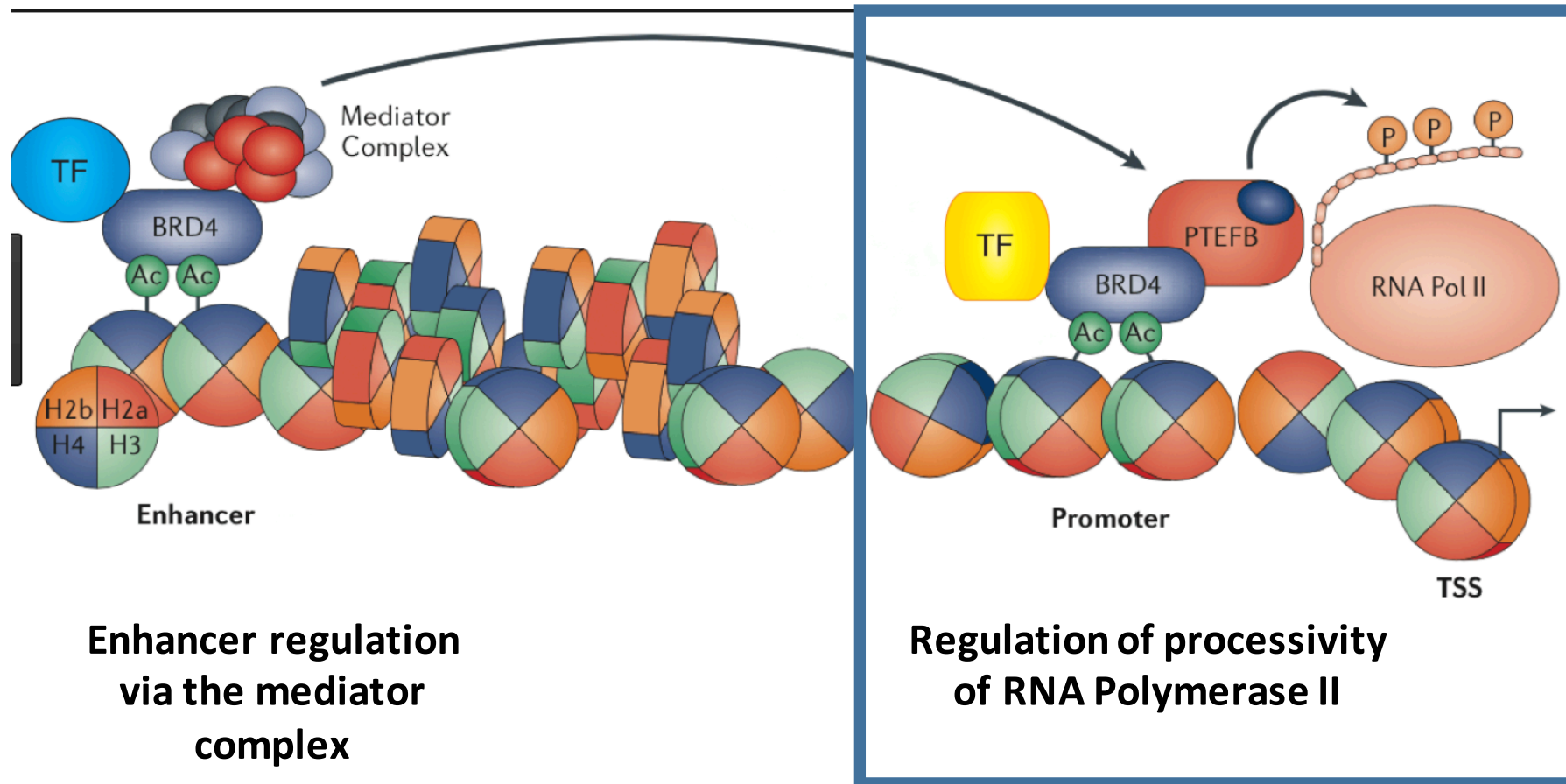

Elongation of transcription in eukaryotes

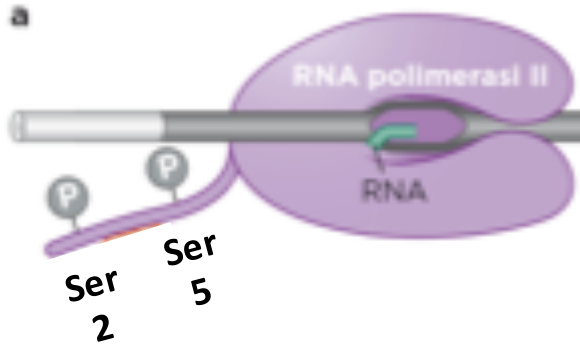

coda carbossi-terminale (CTD) dell' RNA Pol II

→ *Eucarioti 25- 52 Repetizioni YSPTSPS*

→ *Diversi enzimi vengono reclutati a secondo dello stato di fosforilazione*

→ ***Fattori della maturazione e allungamento sono reclutati sulla CTD***

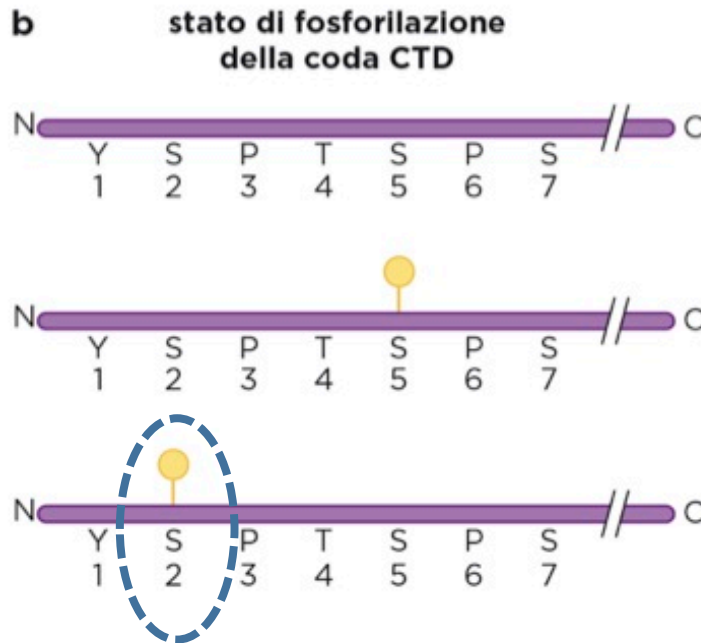

P-TEFb

fase della trascrizione

reclutamento dei fattori necessari al processamento dell'RNA

preinizio

—

evasione dal promotore

formazione del Cap

allungamento

splicing

Elongation of transcription in eukaryotes

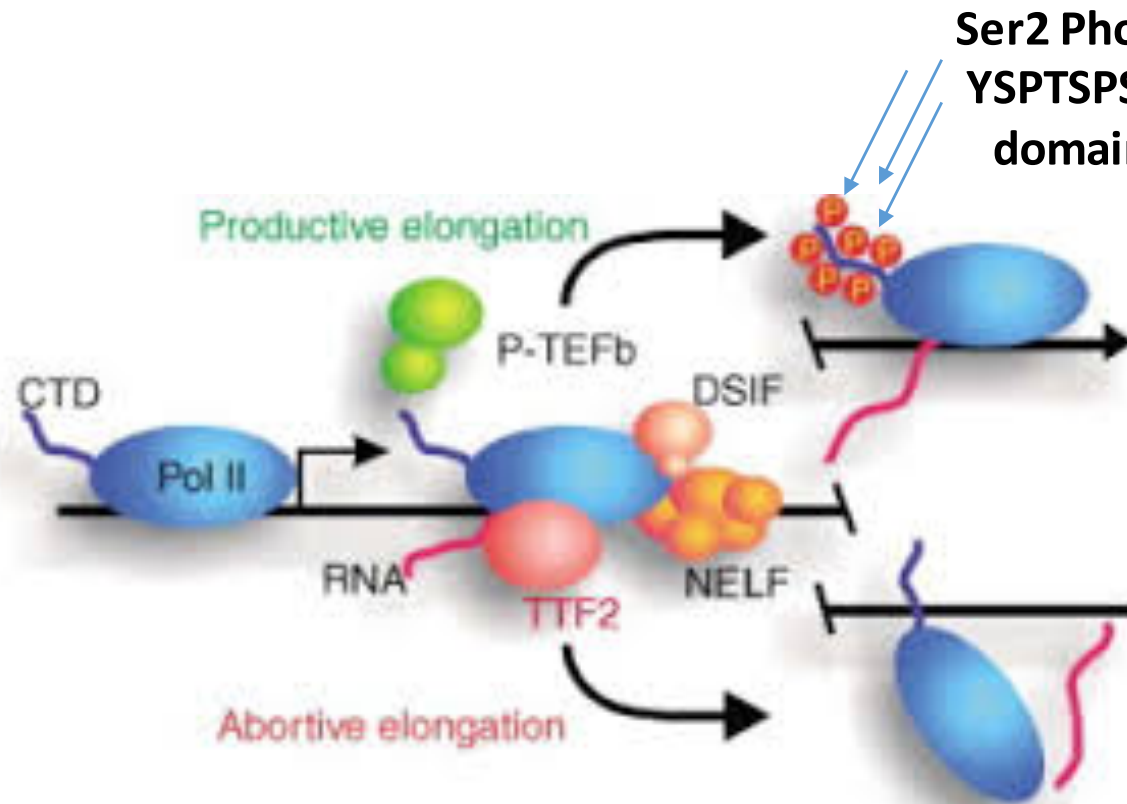

Ser2 Phosphorylation on
YSPTSPS repeats in CTD
domain of RNA-Pol II

1. P-TEFb:
Kinase that
phosphorylates
DSIF and NELF
Phosphorylated NELF
released from
RNA polymerase

2. P-TEFb:
Phosphorylates Ser-2 at
RNA Pol II CTD

**3. ELONGATION OF
TRANSCRIPTION**

P-TEFb: Kinase

NELF-DSIF: repressors of transcriptional elongation

P-TEFb consists of CDK9 and CycT1.

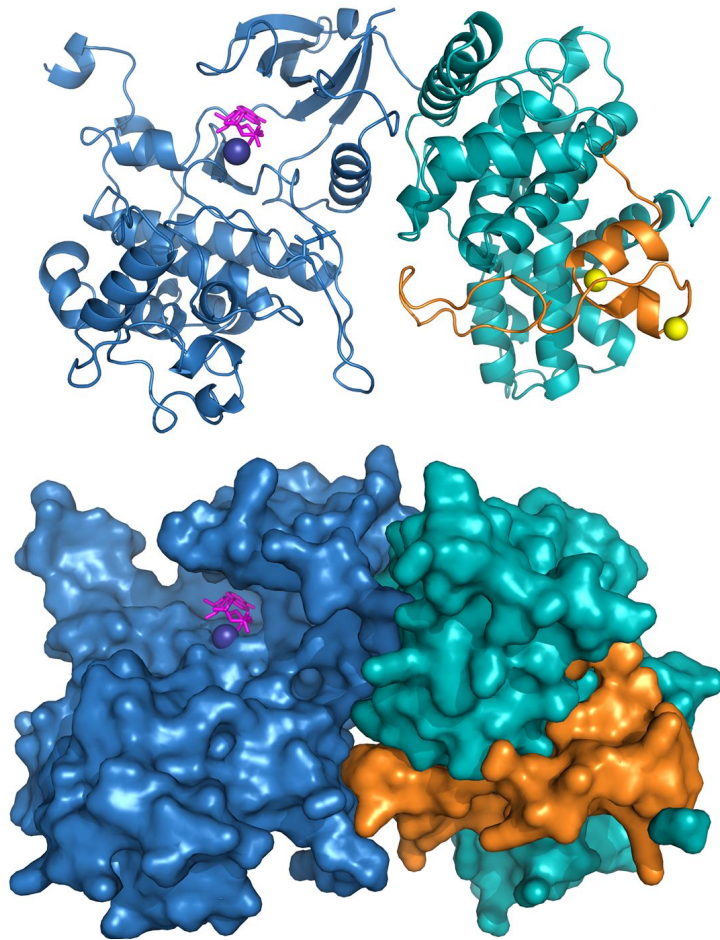

Structure of P-TEFb bound by HIV Tat

Cdk9 (blue),
cyclin T1 (cyan)
Tat (orange),
ATP (magenta)
magnesium (purple)
zinc atoms (yellow).

P-TEFb is a cyclin dependent kinase containing the catalytic subunit, Cdk9, and a regulatory subunit, cyclin T in Drosophila.

In humans there are multiple forms of P-TEFb which contain Cdk9 and one of several cyclin subunits, cyclin T1, T2, and K

NOTE: In HIV infected cells the HIV1 protein Tat is controlling P-TEFb to ensure expression of viral genes

P-TEFb is essential for Tat transactivation of HIV-1 transcription.

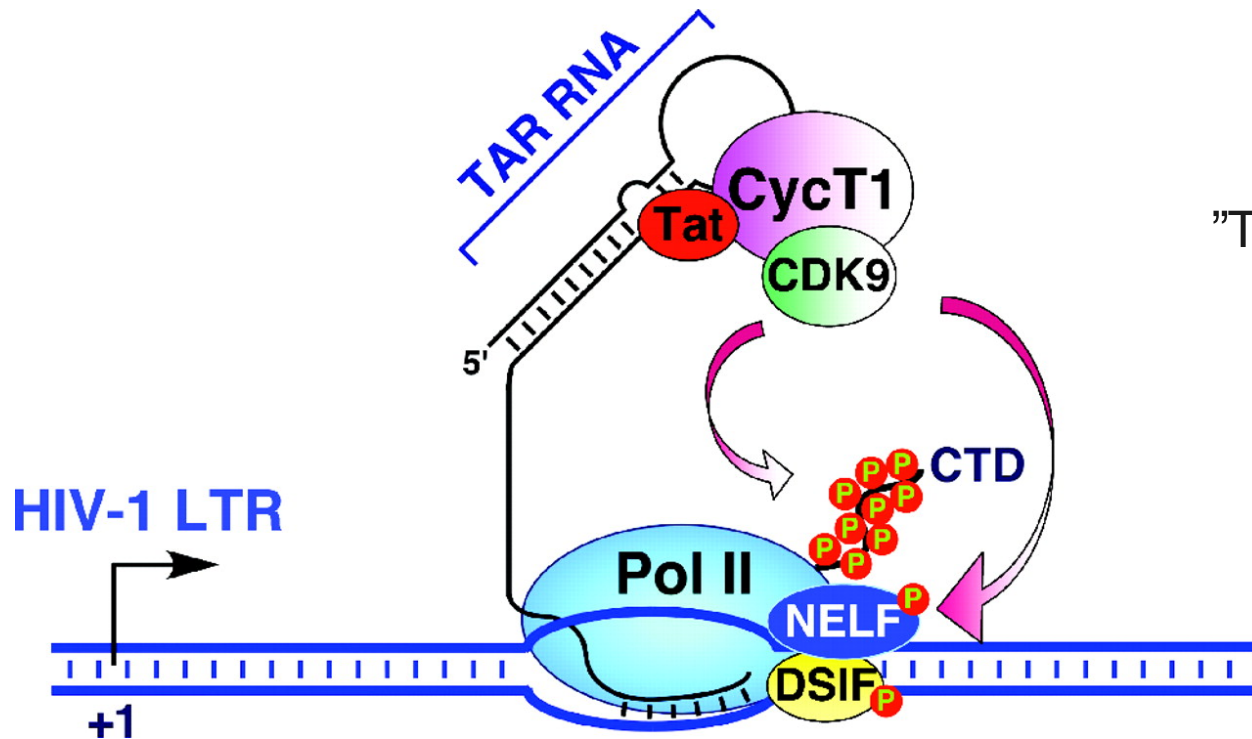

"Tat: Trans-Activator of Transcription"

HIV-1 protein Tat uses P-TEFb to stop the negative effect of NELF/DSIF on elongation of transcription of viral genes

P-TEFb is essential for Tat transactivation of HIV-1 transcription. Shortly after transcription is initiated from the HIV-1 promoter, the progression of Pol II is stalled by the concerted actions of negative elongation factors DSIF and NELF. For Pol II to escape from this promoter-proximal pausing, the HIV-1-encoded Tat protein binds to host cellular P-TEFb and recruits it to the stalled Pol II through forming a stable ternary complex involving the TAR RNA stem-loop structure located near the 5' end of the nascent viral transcript. Subsequently, P-TEFb phosphorylates the Pol II CTD as well as the negative elongation factors to stimulate processive elongation.

P-TEFb is inactive when present in a snRNP complex

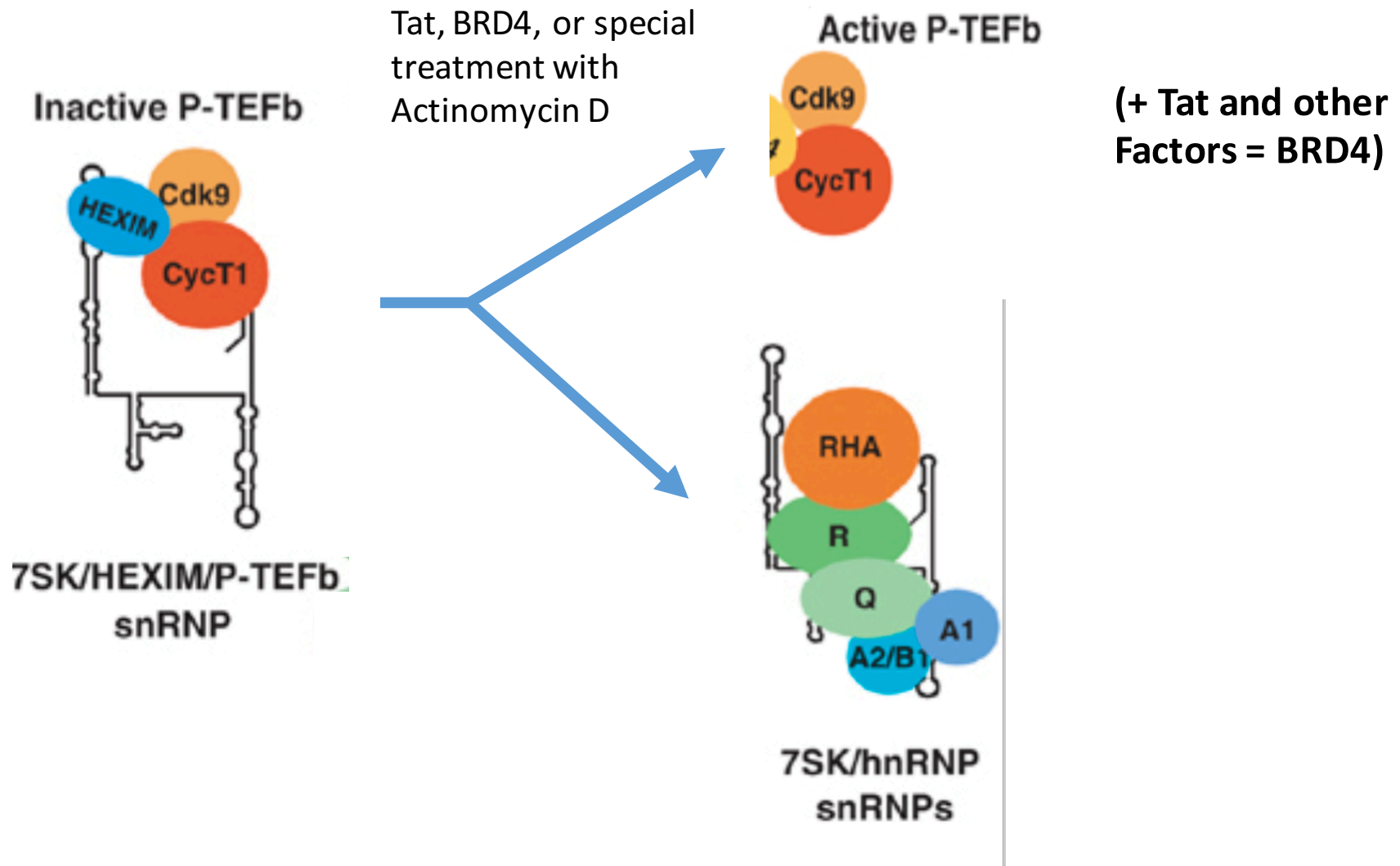

Releasing P-TEFb from snRNP complex results active P-TEFb complex → kinase activity: ON

Activation of P-TEFb in HIV virus infected cells and normal context

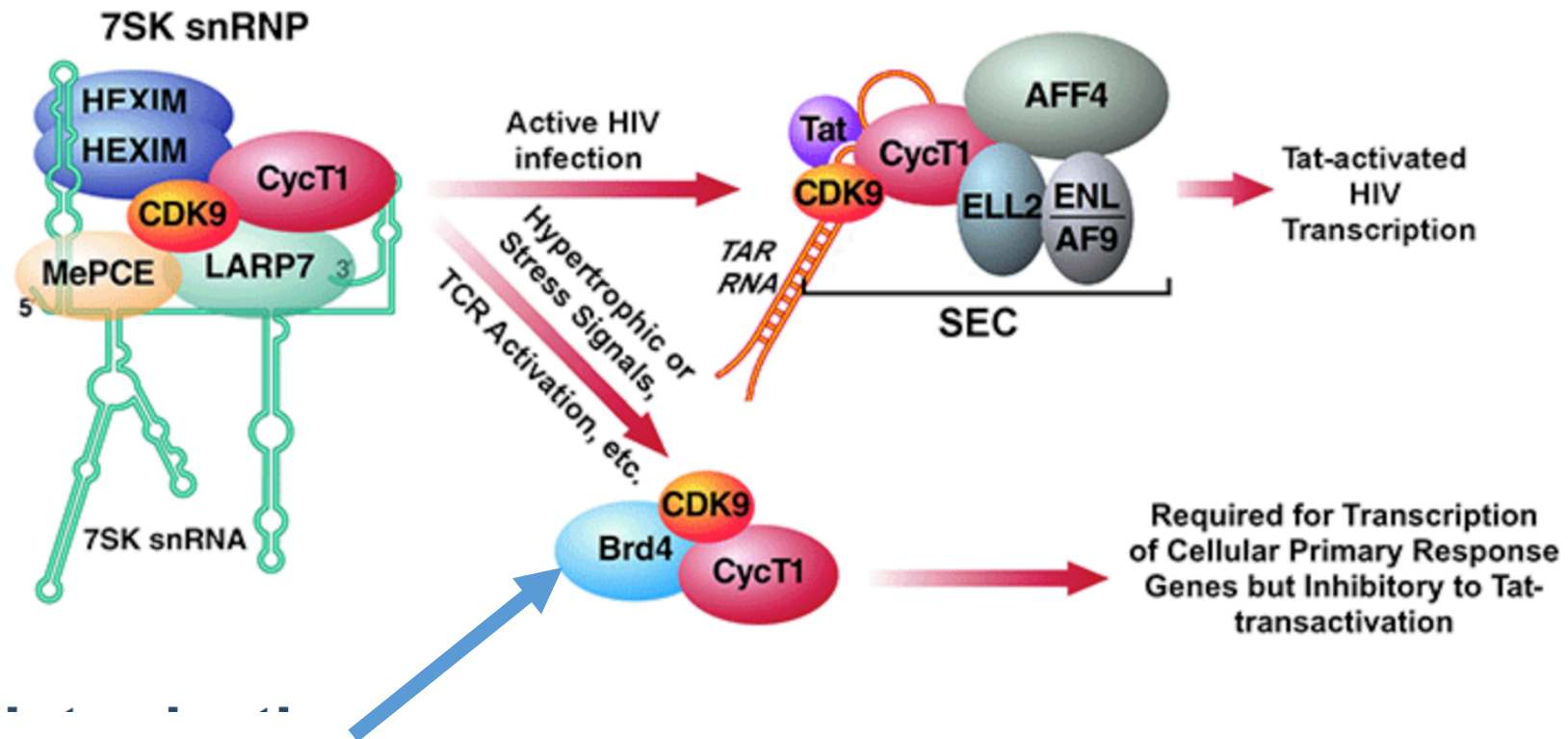

The elongation phase of RNA polymerase (Pol) II transcription is widely used to regulate the expression of metazoan genes, especially those for cell growth, renewal and differentiation. Composed of CDK9 and cyclin T (CycT), the positive transcription elongation factor b (P-TEFb) is one of the most important factors that promote the transition of Pol II from promoter-proximal pausing into productive elongation. P-TEFb acts by phosphorylating the Pol II C-terminal domain (CTD) and negative elongation factors to antagonize the latter's inhibitory effects. This leads to the synthesis of full-length RNA transcripts and the coupling of transcription with pre-mRNA processing.

BRD4 is in a complex with Cdk9 and CyclinT1

Question: What proteins interact with BRD4???

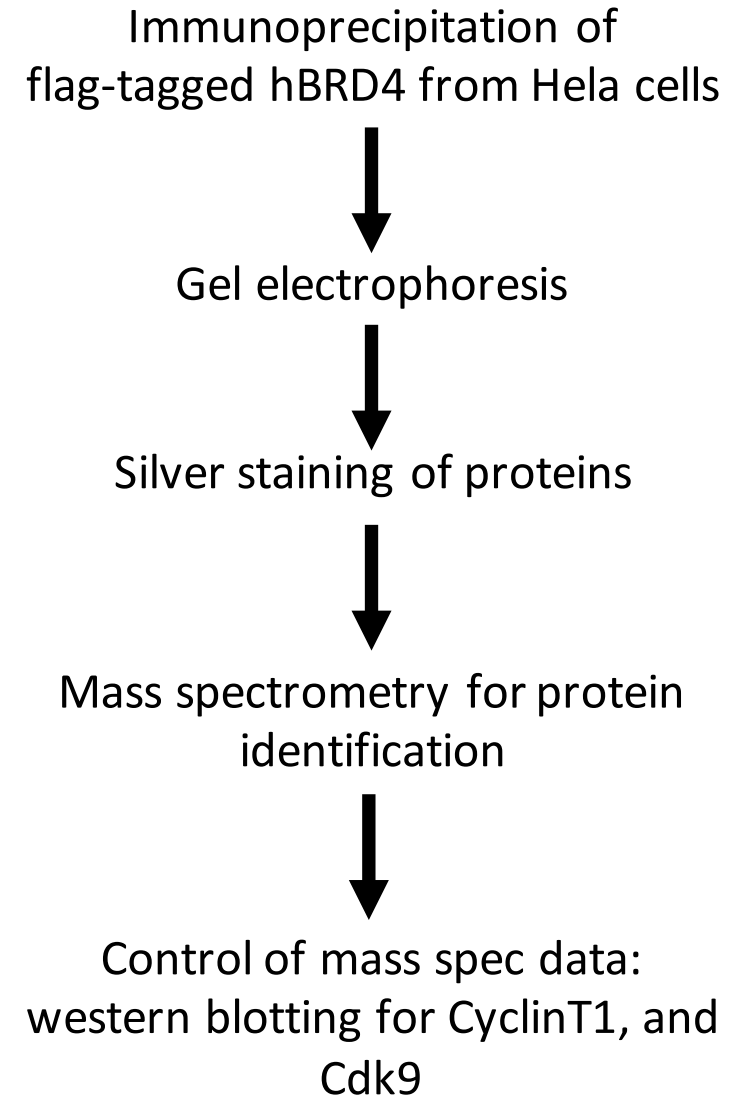
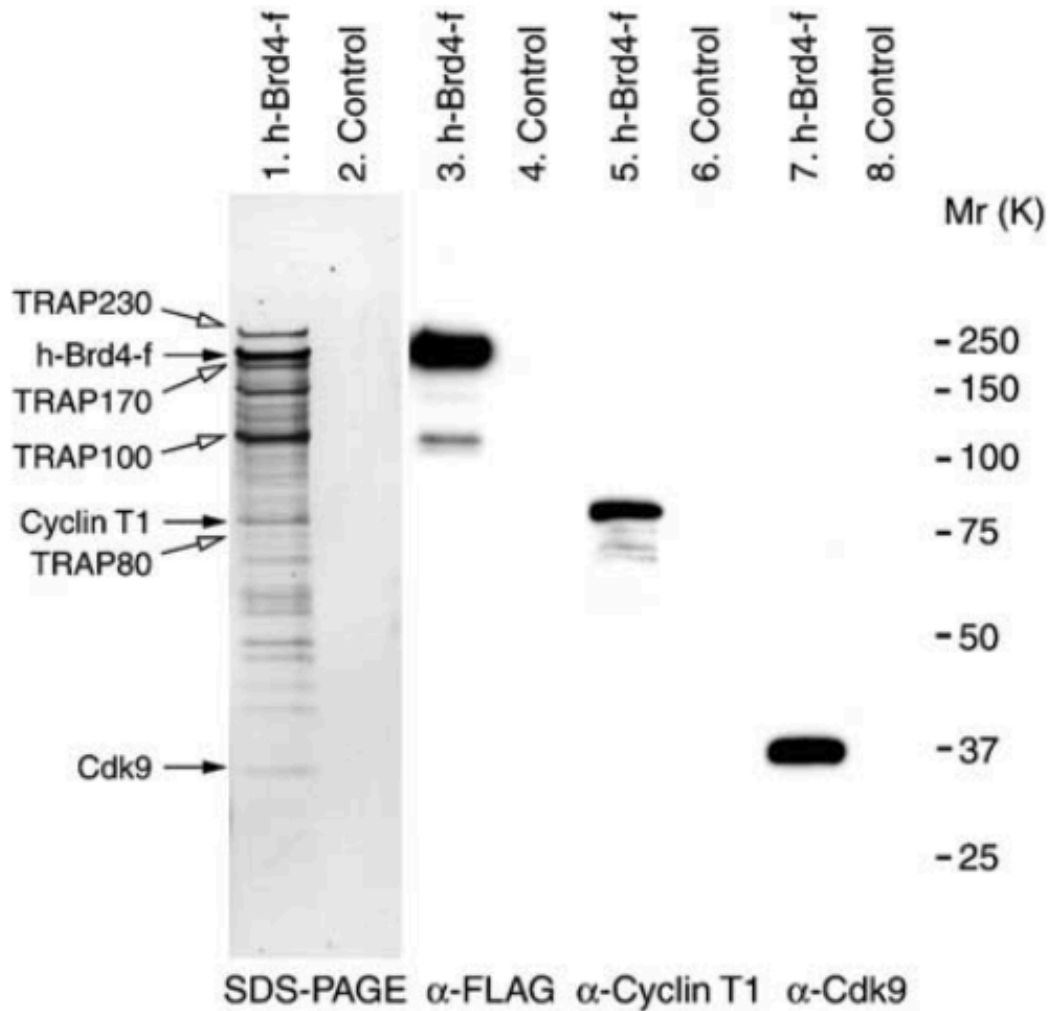

BRD4 is in a complex with Cdk9 and CyclinT1

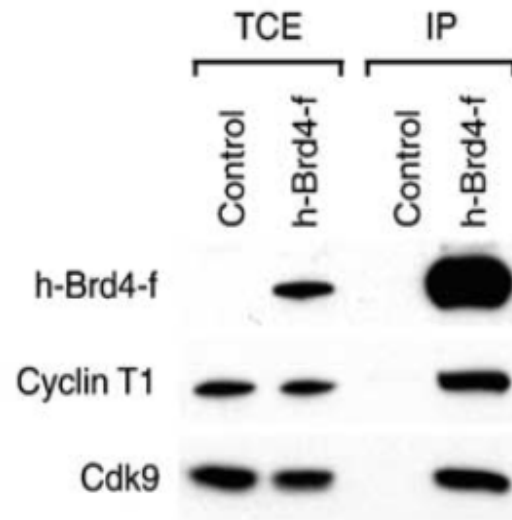

Direct immunoprecipitation



Cells transfected with flag tagged human BRD4



IP anti-Flag



Western blot:

Anti-Brd4

Anti-Cyclin T1

Anti-Cdk9

BRD4 co-localizes with CyclinT1 and RNA polymerase II

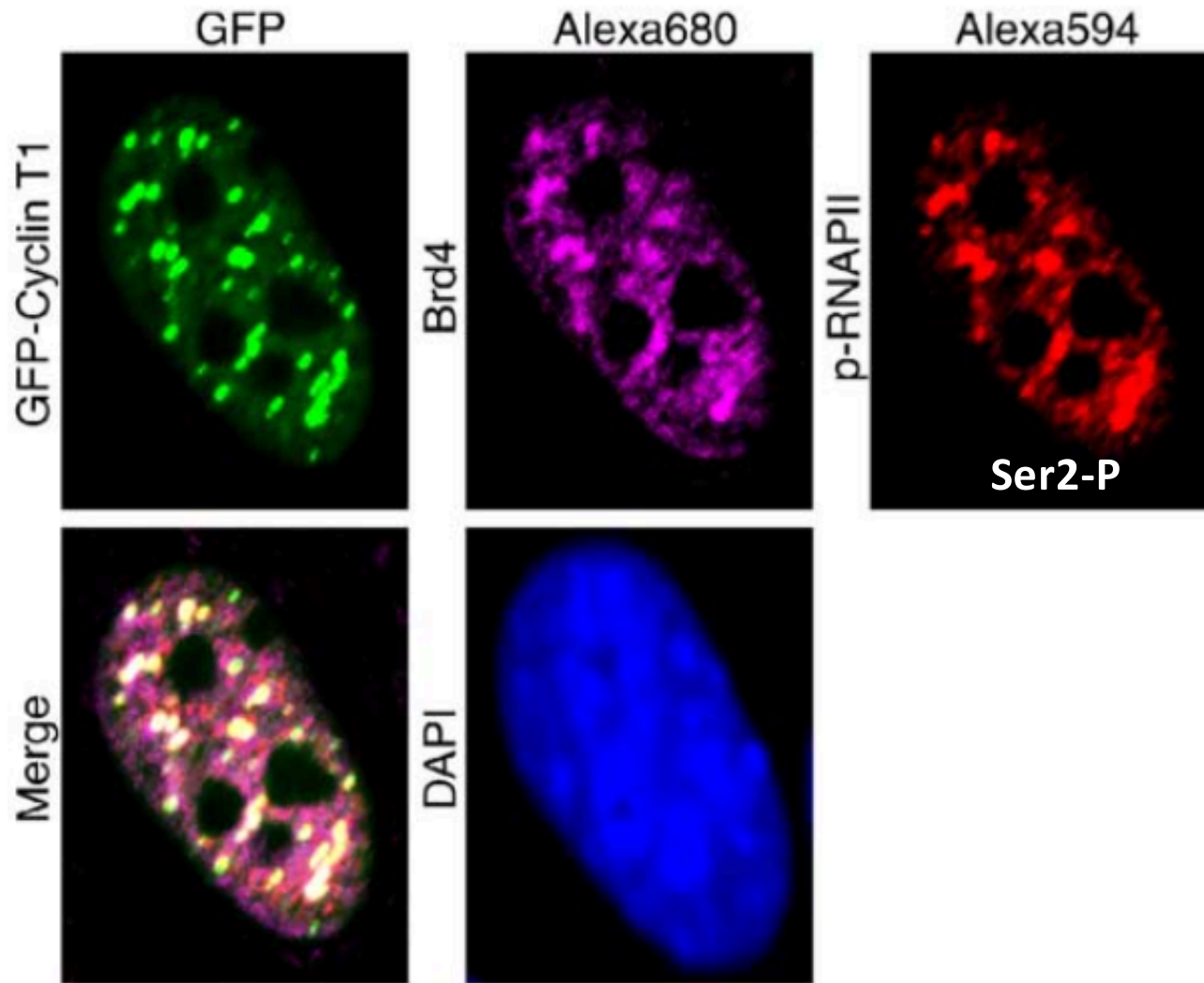

How do BRD4 and 7SK-HEXIM relate to CDK9/CycT1??

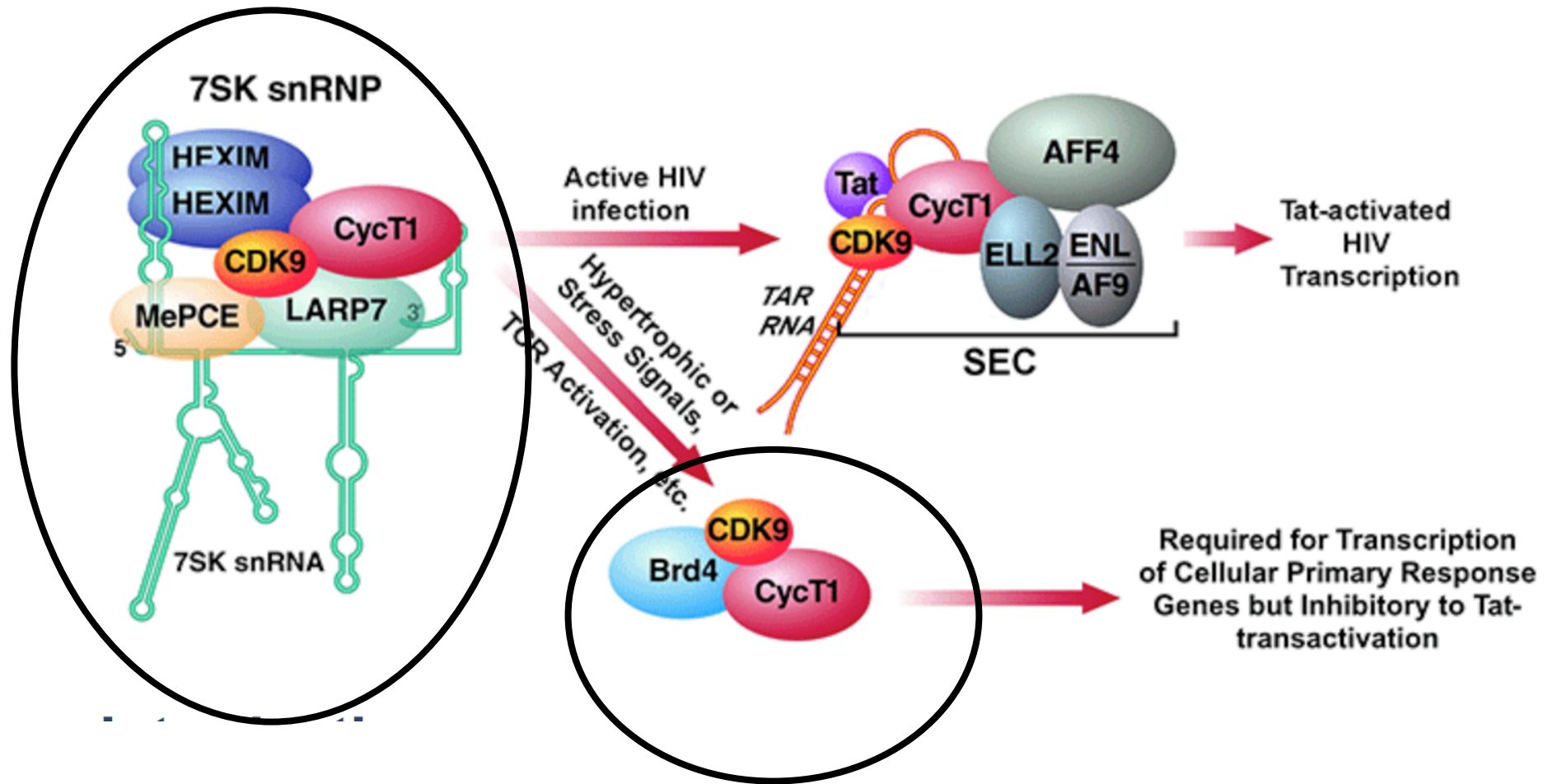

Size exclusion chromatography is an excellent tool to study LARGE protein complexes

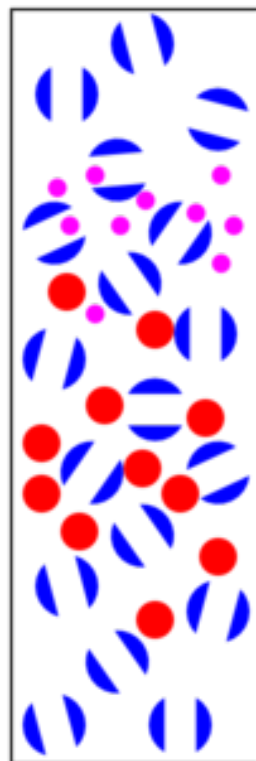

Large particles cannot enter gel and are excluded. They have less volume to traverse and elute sooner.

Small particles can enter gel and have more volume to traverse. They elute later.

chromatogram

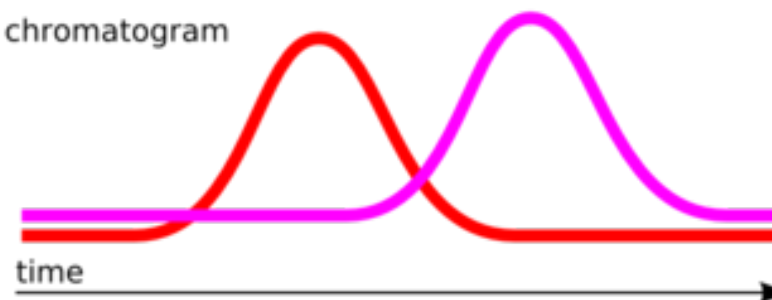

SEC is used primarily for the analysis of large molecules such as proteins or polymers. SEC works by trapping smaller molecules in the pores of the adsorbent materials adsorption ("stationary phases"). This process is usually performed with a column, which consists of a hollow tube tightly packed with extremely small porous polymer beads designed to have pores of different sizes. These pores may be depressions on the surface or channels through the bead. As the solution travels down the column some particles enter into the pores. Larger particles cannot enter into as many pores. The larger the particles, the faster the elution. The larger molecules simply pass by the pores because those molecules are too large to enter the pores. Larger molecules therefore flow through the column more quickly than smaller molecules, that is, the smaller the molecule, the longer the retention time.

Size exclusion chromatography is an excellent tool to study LARGE protein complexes

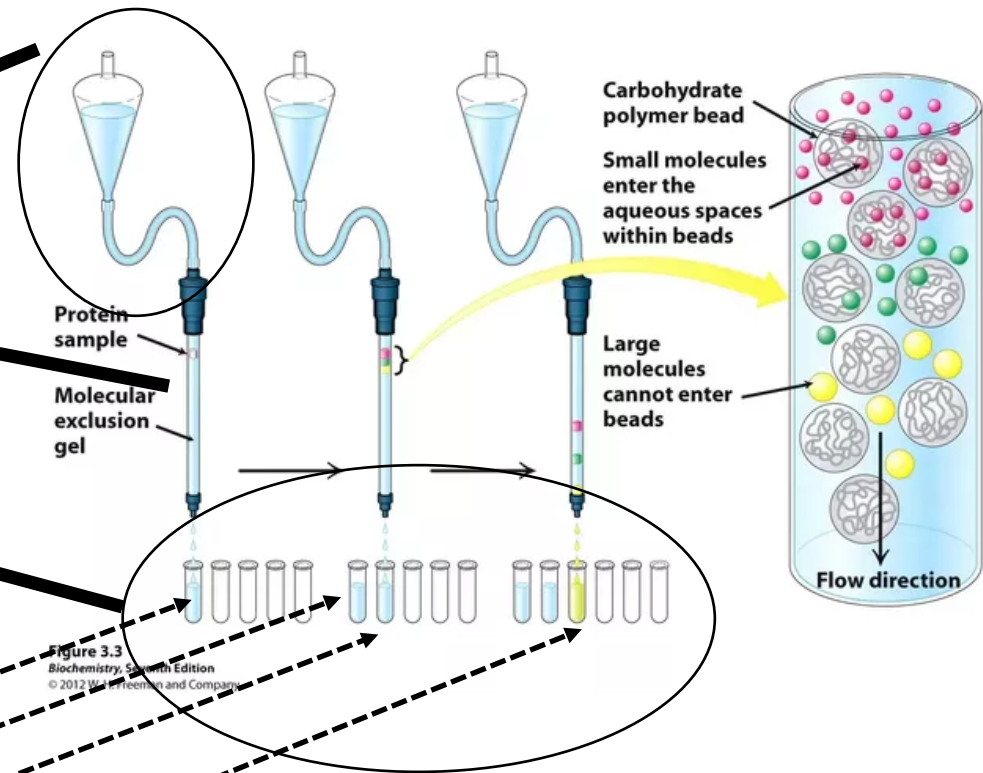
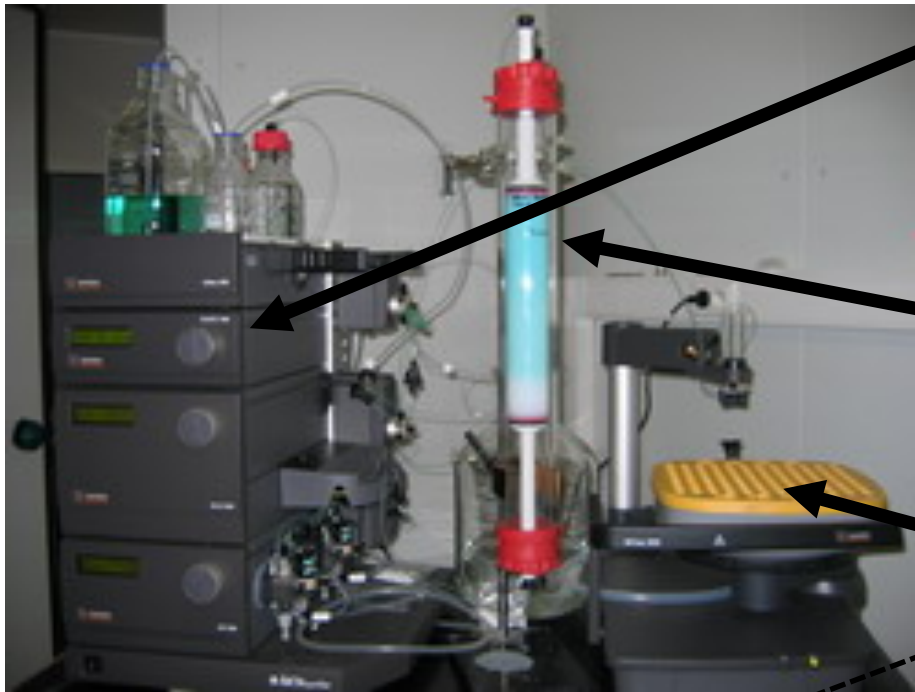
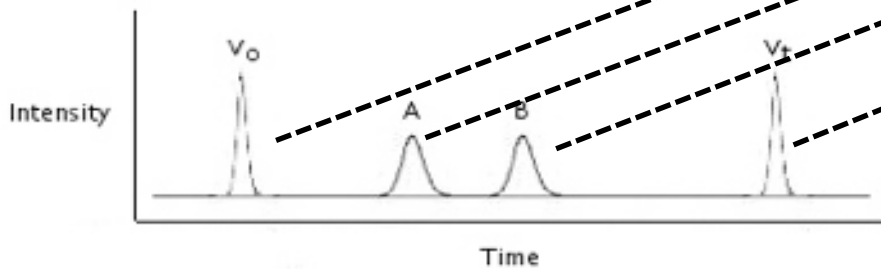

Figure 3.3
Biochemistry, Seventh Edition
© 2012 Wolters Kluwer Health | Lippincott Williams and Wilkins



Eluted protein complexes in eluates can be run on protein gels
→ western, mass spec, etc

Stable protein complexes that consist of many proteins co-elute. Even if the individual proteins might be small

Size exclusion chromatography on P-TEFb complexes

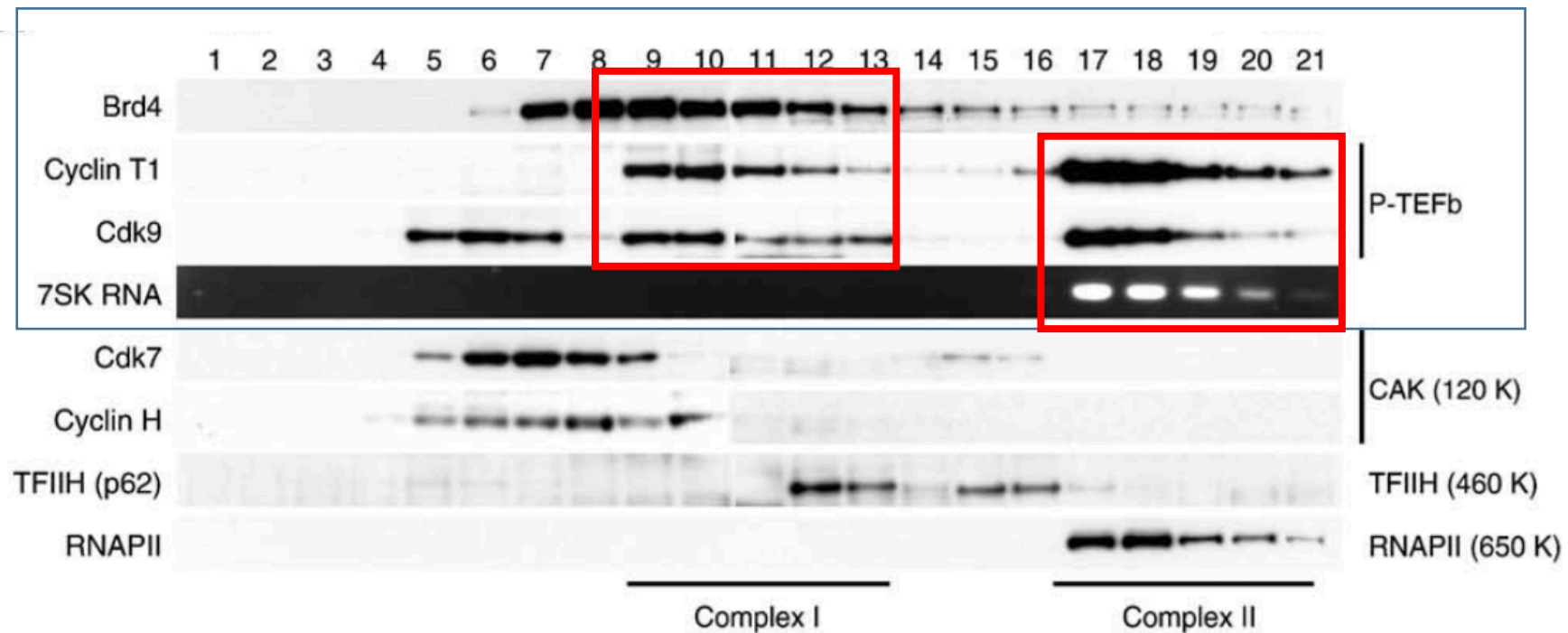

- 2 mutually exclusive complexes:**
- BRD4 – CycT1 – Cdk9: ACTIVE P-TEFb
- no 7SK snRNA; RNA PolII released after phosphorylation of NELF, DSIF
- 7SK – CycT1 – Cdk9: INACTIVE P-TEFb
- RNA Pol II associated with complex that contains 7SK snRNA

Alternative approach: glycerol centrifugation gradient

DOES BRD4 HAS A POSITIVE EFFECT ON ELONGATION?

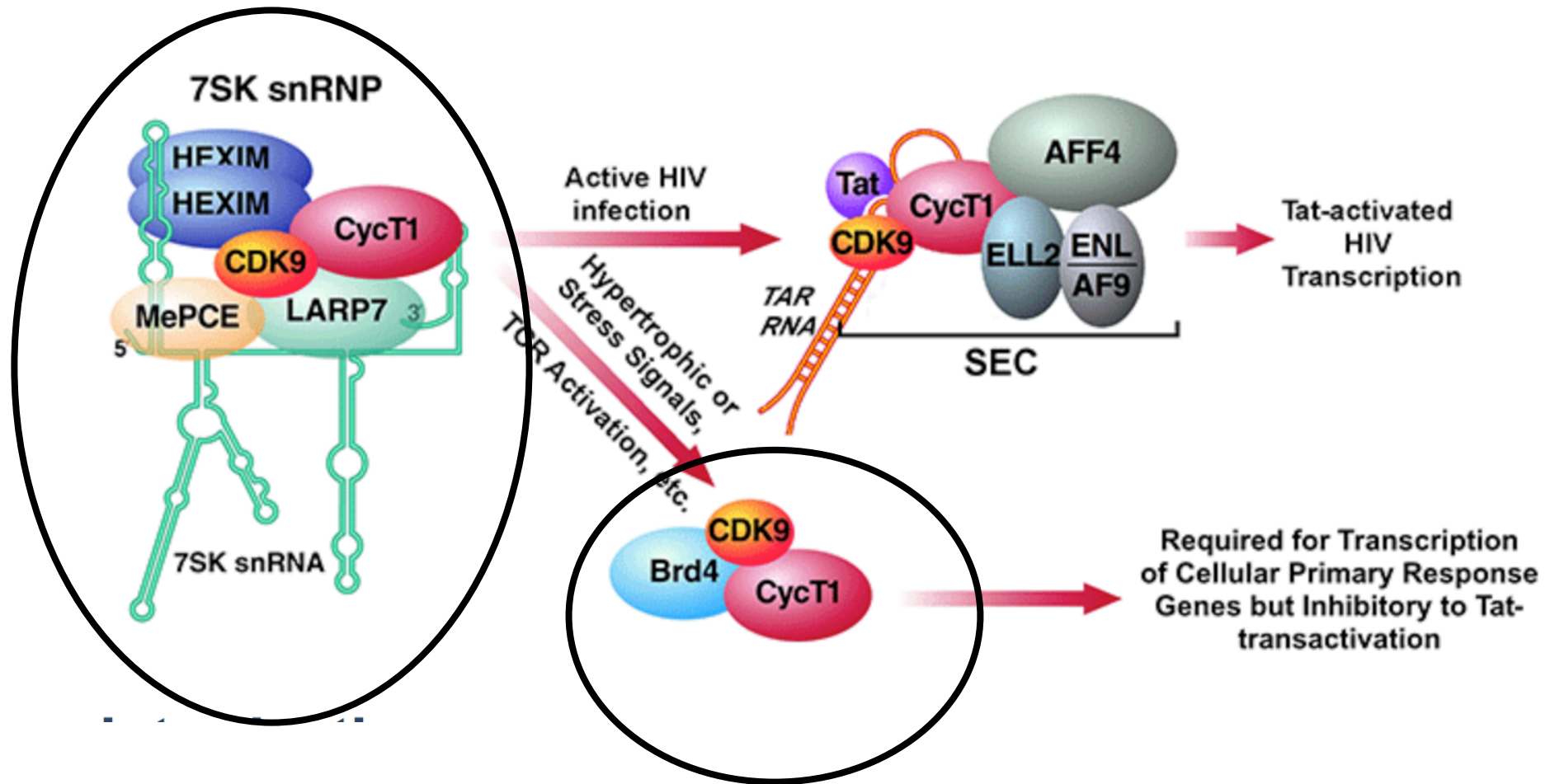

DOES BRD4 HAS A POSITIVE EFFECT ON ELONGATION?

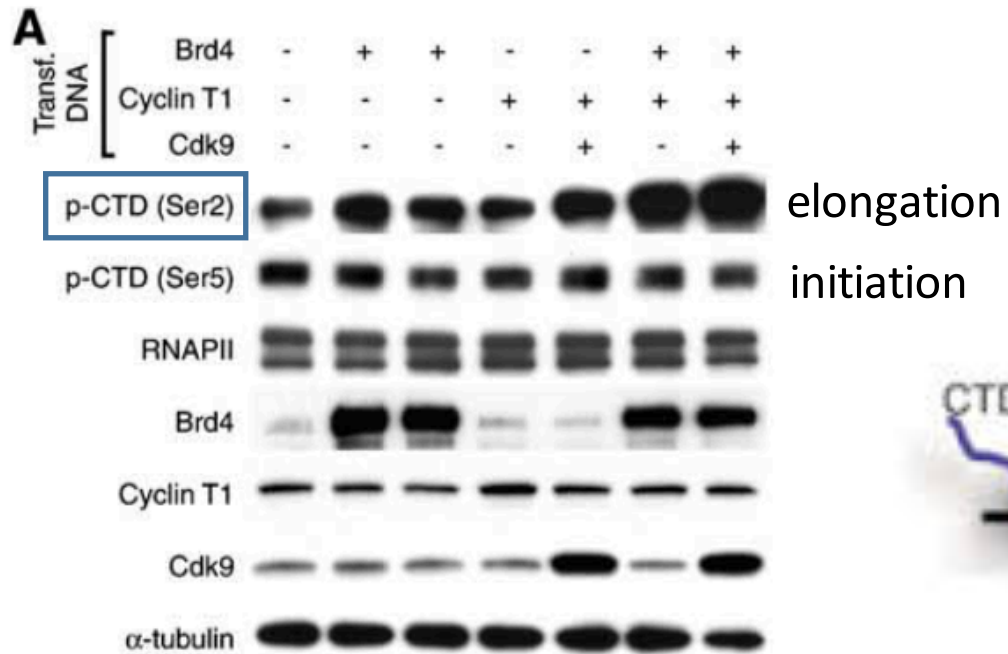

Cells transiently transfected (+) or not (-)
with Brd4 or CyclinT1 or Cdk1

Readout: change of CTD phosphorylation of RNA Pol II
= gain of function approach

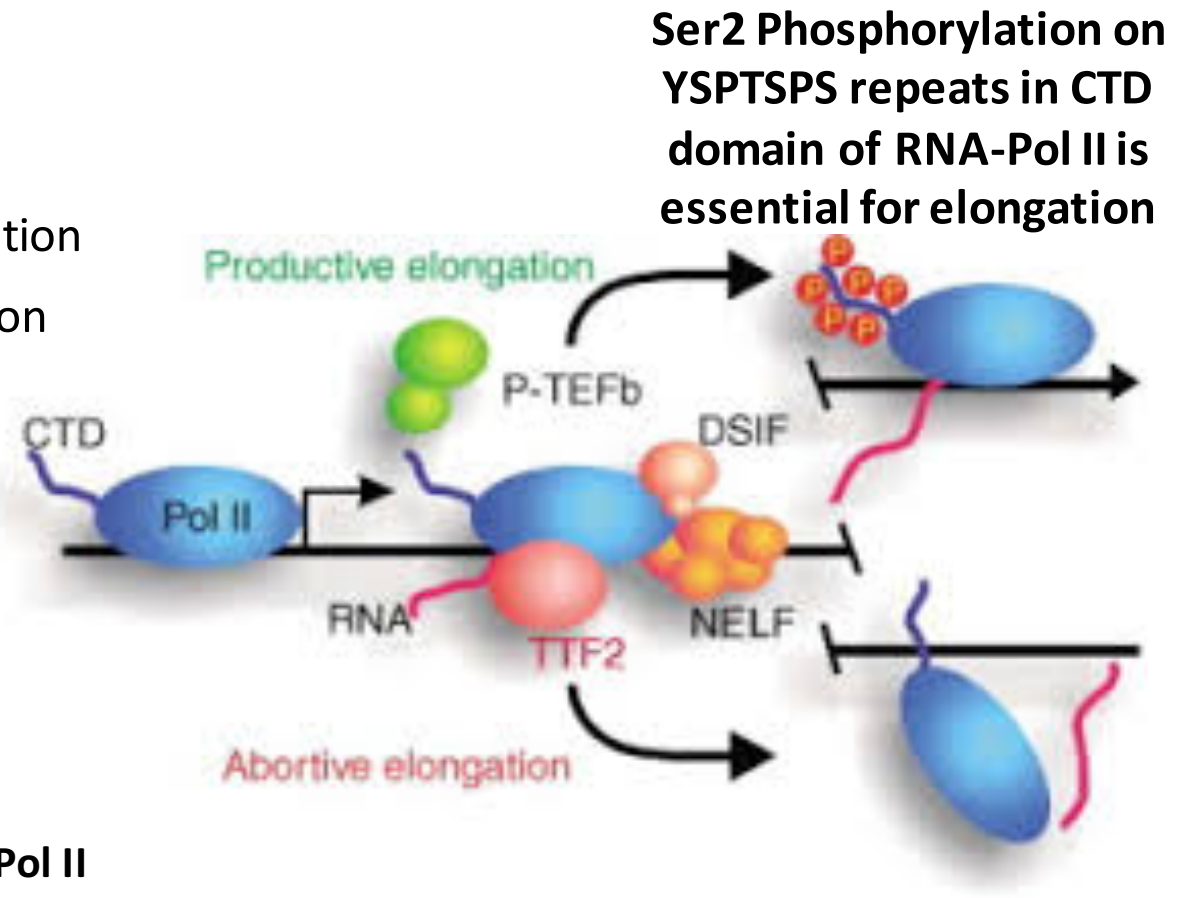

**Ectopic expression of Brd4 increases the phosphorylation levels of CTD Ser2
Ser5 remains unchanged!!!**

DOES BRD4 HAS A POSITIVE EFFECT ON PROMOTER ACTIVITY?

Functional test with reporter → response to BRD4??

Reporter are stably integrated into cells; cells are transiently transfected with different amounts of Brd4 expression vector

A HIV promoter located in the LTR domain of HIV-1; fused to a luciferase reporter



c-Myc promoter fused to a luciferase reporter

c-Myc promoter



c-Jun promoter fused to a luciferase reporter

c-Jun promoter

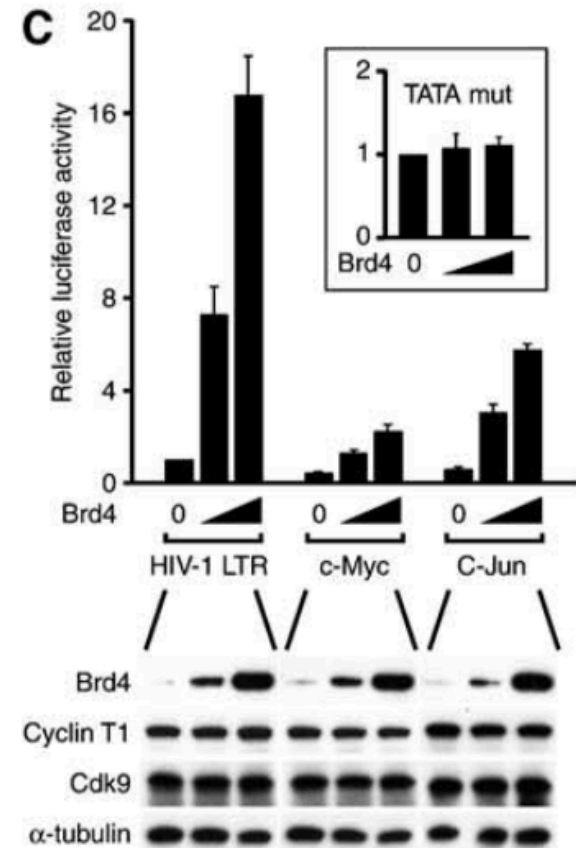
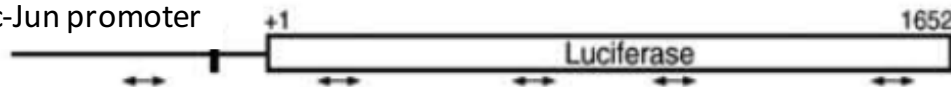

Ectopic BRD4 increases luc-activity

DOES BRD4 BRING MORE P-TEFb TO REPORTER

Reporter are stably integrated into cells; cells are transiently transfected with Brd4 siRNA → ChIP anti Brd4 and P-TEFb

A HIV promoter located in the LTR domain of HIV-1; fused to a luciferase reporter



Arrows indicate the position of PCR oligos used for ChIP

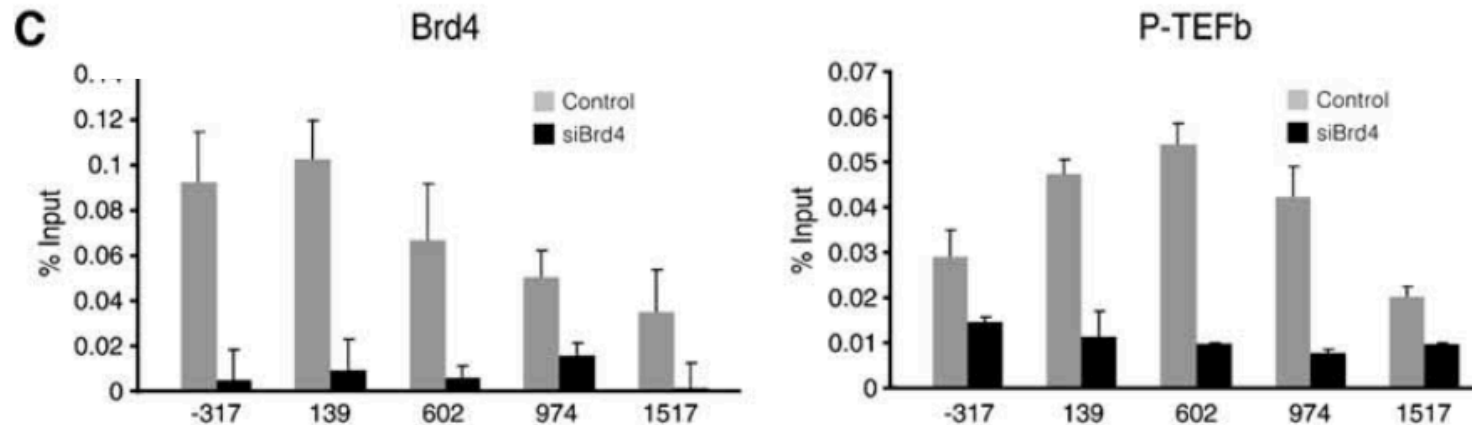

Anti-Cdk9/Anti-CycT1 ChIP on luciferase reporter

Loss of Brd4 reduces the amount of P-TEFb on reporter

WHAT ABOUT THE ACETYLATION?

Reporter are stably integrated into cells; cells are transfected with Brd4 siRNAs/control siRNAs and treated or not treated with TSA
→ ChIP anti Brd4 and P-TEFb

TSA IS AN INHIBITOR OF HDACs → INCREASES CHROMATIN ACETYLATION

A HIV promoter located in the LTR domain of HIV-1; fused to a luciferase reporter



Arrows indicate the position of PCR oligos used for ChIP

ChIP on reporter cell line, that was treated or non-treated with TSA

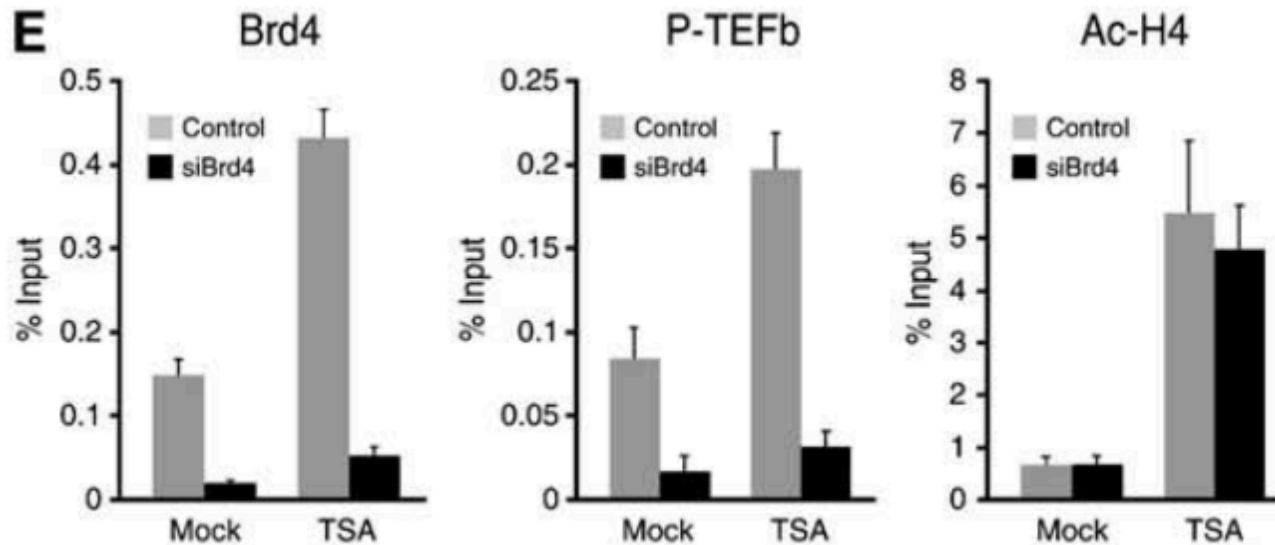

TSA treatment increases Acetylation and increases BRD4/P-TEFb at luciferase reporter

BRD4 MEDIATES ELONGATION BY RECRUITING P-TEFb AND CHANGING THE P-STATUS AT RNA-Pol CTD

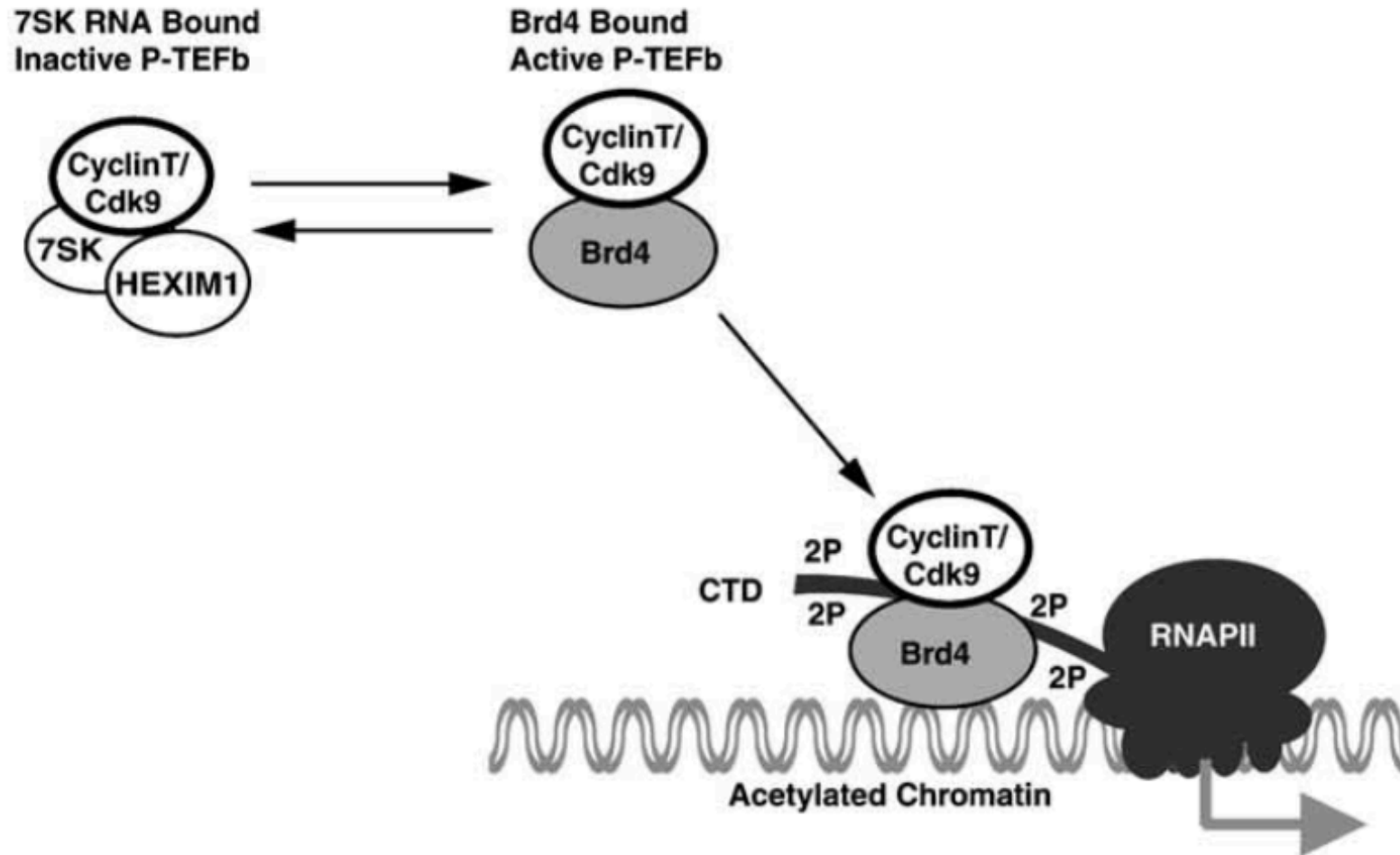

Brd4 interacts with the Mediator complex to activate gene expression

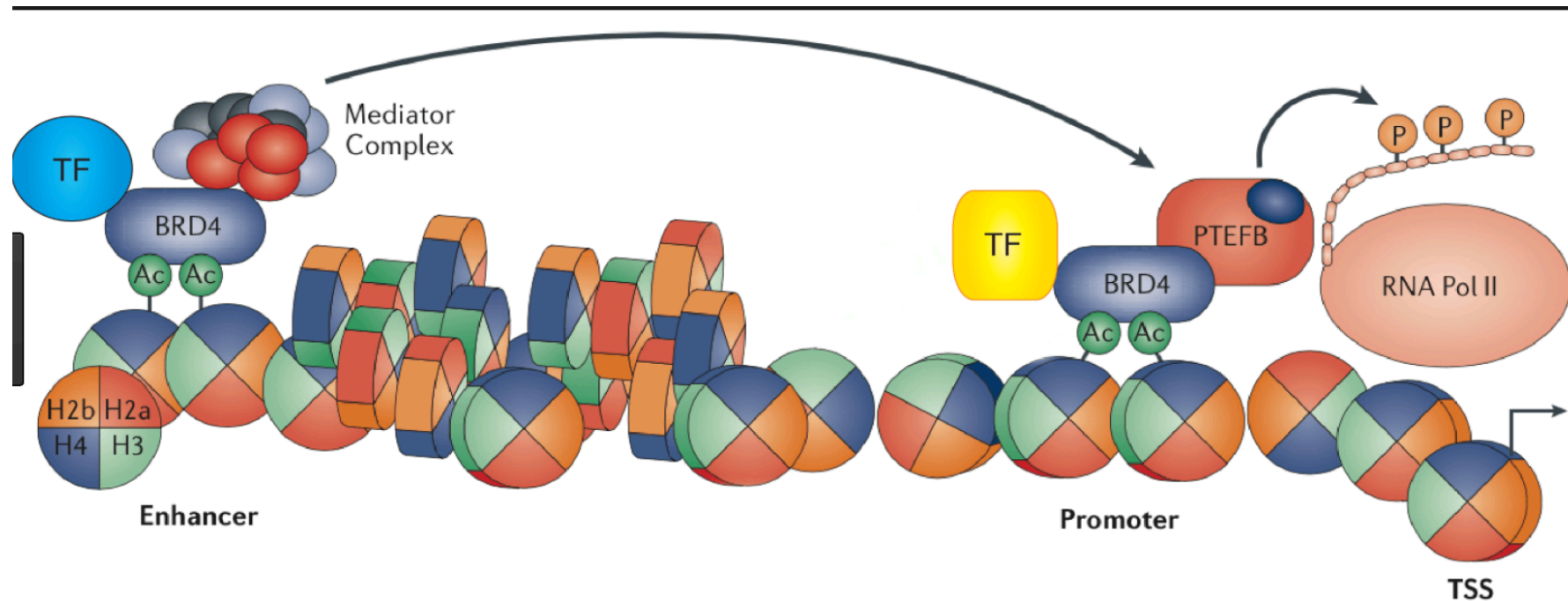

Enhancer regulation via the mediator complex

Regulation of processivity of RNA Polymerase II

BRD4 can directly interact with Transcription factors such as: p53, YY1, c-Jun, AP2, C/EBPalpha, C/EBPbeta, Myc/Max heterodimer

P-TEFb activity is controlled in eukaryotic cells

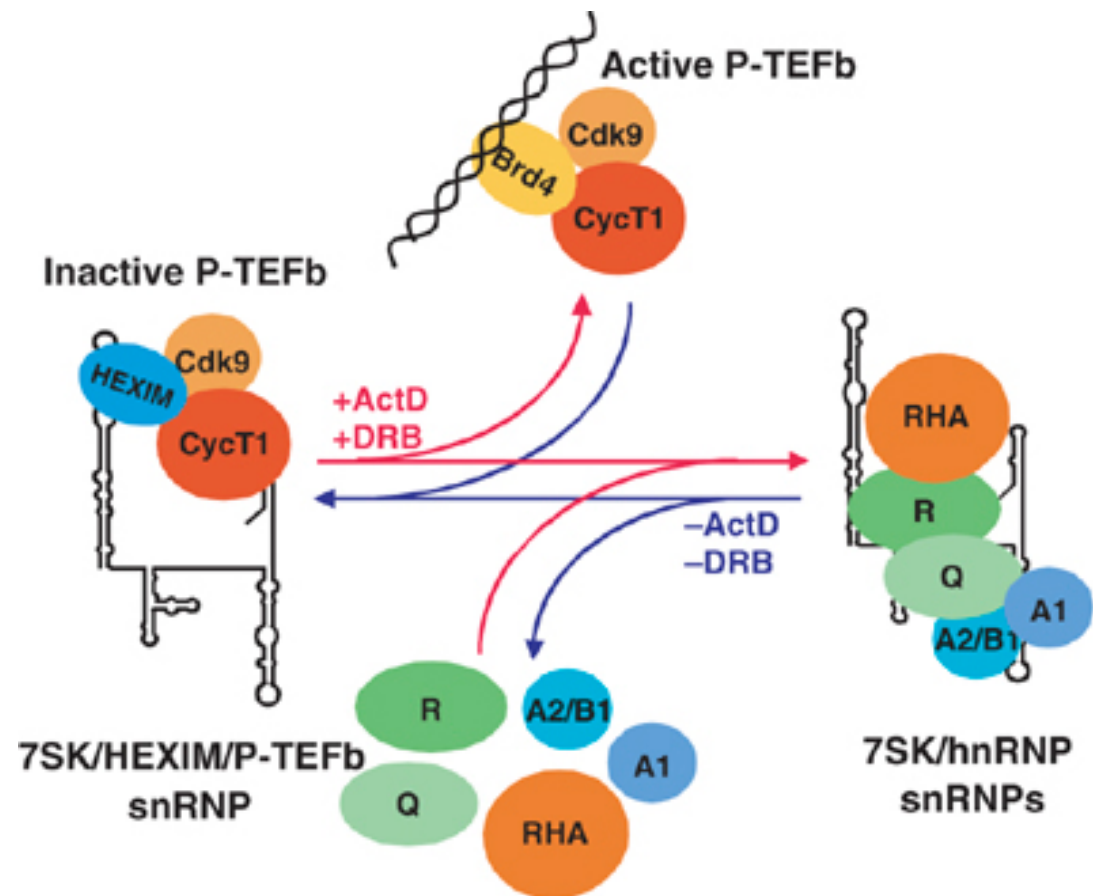

P-TEFb is inactivated when complexed in 7SK snRNPs

snRNPs (pronounced "snurps"), or small nuclear ribonucleo proteins

Elodie Van Herreweghe et al. EMBO J. 2007;26:3570-3580

A model for regulation of the nuclear level of active P-TEFb by dynamic and reversible remodeling of 7SK snRNPs. In exponentially growing HeLa cells, about 50% of P-TEFb is sequestered into the 7SK/HEXIM1/P-TEFb snRNP, while the other half associates with the bromodomain protein 4 (Brd4) that likely recruits active P-TEFb to chromatin templates. Transcription inhibition by ActD or DRB treatment induces dissociation of P-TEFb and HEXIM1 from the 7SK snRNA and at the same time, facilitates binding of RHA, hnRNP A1, A2/B1, R and Q proteins.