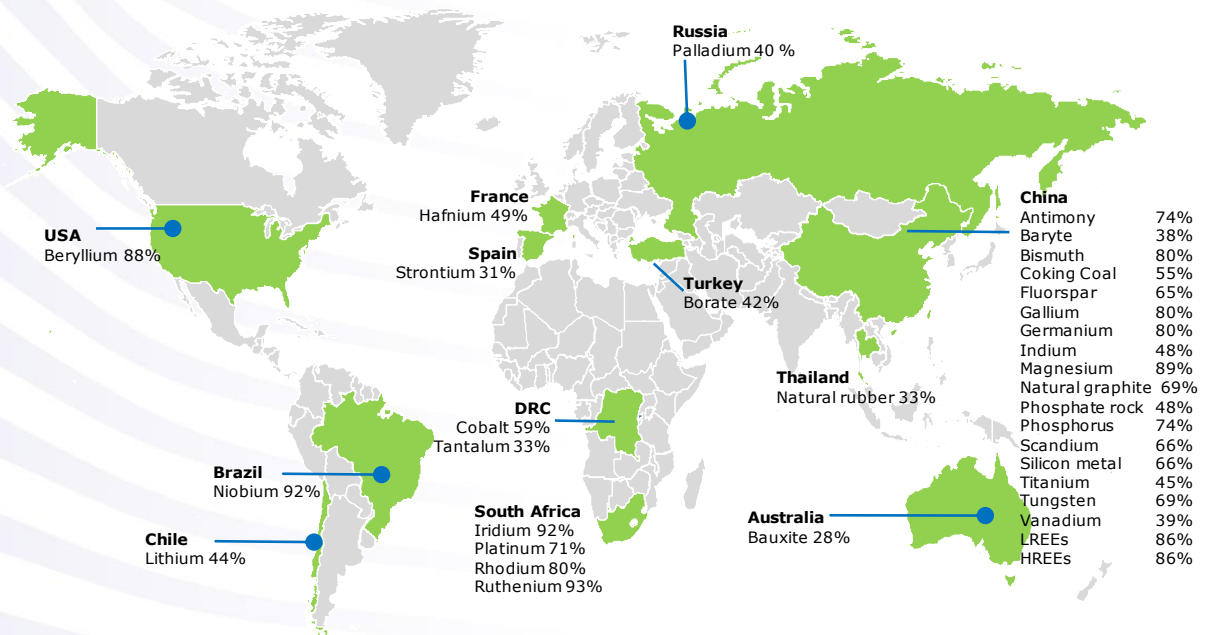


# Study on the EU's list of Critical Raw Materials (2020)

Critical Raw Materials Factsheets (Final)



**Authors: Cynthia EL Latunussa, Konstantinos Georgitzikis, Cristina Torres de Matos, Milan Grohol, Umberto Eynard, Dominic Wittmer, Lucia Mancini, Manuela Unguru, Claudiu Pavel, Samuel Carrara, Fabrice Mathieux, David Pennington, Gian Andrea Blengini.**

## **LEGAL NOTICE**

This document has been prepared for the European Commission however it reflects the views only of the authors, and the Commission cannot be held responsible for any use which may be made of the information contained therein.

More information on the European Union is available on the Internet (<http://www.europa.eu>).

Luxembourg: Publications Office of the European Union, 2020

Print	ISBN 978-92-76-21054-2	doi: 10.2873/631546	ET-03-20-530-EN-C
PDF	ISBN 978-92-76-21053-5	doi: 10.2873/92480	ET-03-20-530-EN-N

© European Union, 2020

***EUROPE DIRECT is a service to help you find answers  
to your questions about the European Union***

Freephone number (\*):  
00 800 6 7 8 9 10 11

(\* ) The information given is free, as are most calls (though some operators, phone boxes or hotels may charge you)

Reproduction is authorised provided the source is acknowledged.

How to cite this report: "European Commission, Study on the EU's list of Critical Raw Materials (2020), Factsheets on Critical Raw Materials"

## **EUROPEAN COMMISSION**

Directorate-General for Internal Market, Industry, Entrepreneurship and SMEs | Joint Research Centre  
Directorate GROW.C | JRC.D  
Unit GROW.C.2 – Energy-intensive Industries and Raw Materials | JRC.D.3 – Land Resources

Contact: GROW.C.2

E-mail: [GROW-C2@ec.europa.eu](mailto:GROW-C2@ec.europa.eu)

European Commission  
B-1049 Brussels

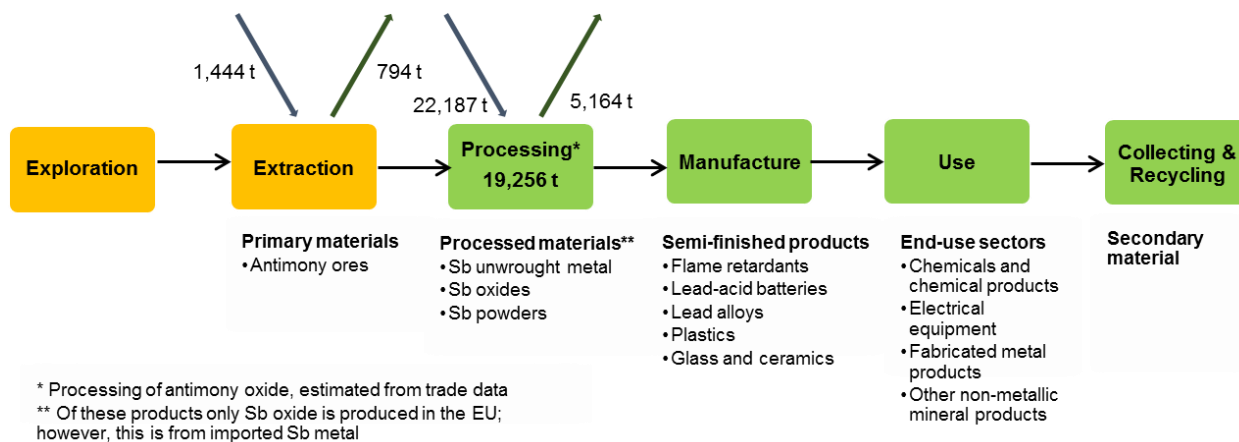
# CONTENTS

---

Contents .....	3
1 Antimony.....	4
2 Baryte.....	24
3 Aluminium and Bauxite .....	37
4 Beryllium.....	81
5 Bismuth.....	96
6 Borates .....	111
7 Cobalt .....	133
8 Coking coal .....	175
9 Fluorspar .....	202
10 Gallium.....	220
11 Germanium .....	236
12 Hafnium.....	254
13 Indium .....	270
14 Lithium .....	287
15 Magnesium.....	323
16 Natural Graphite .....	341
17 Natural Rubber .....	369
18 Niobium .....	383
19 Platinum-Group Metals .....	399
20 Phosphate rock and Elemental Phosphorus .....	525
21 Rare Earth Elements (REE).....	547
22 Scandium.....	690
23 Silicon metal .....	706
24 Strontium .....	723
25 Tantalum .....	735
26 Titanium .....	753
27 Tungsten .....	774
28 Vanadium .....	795

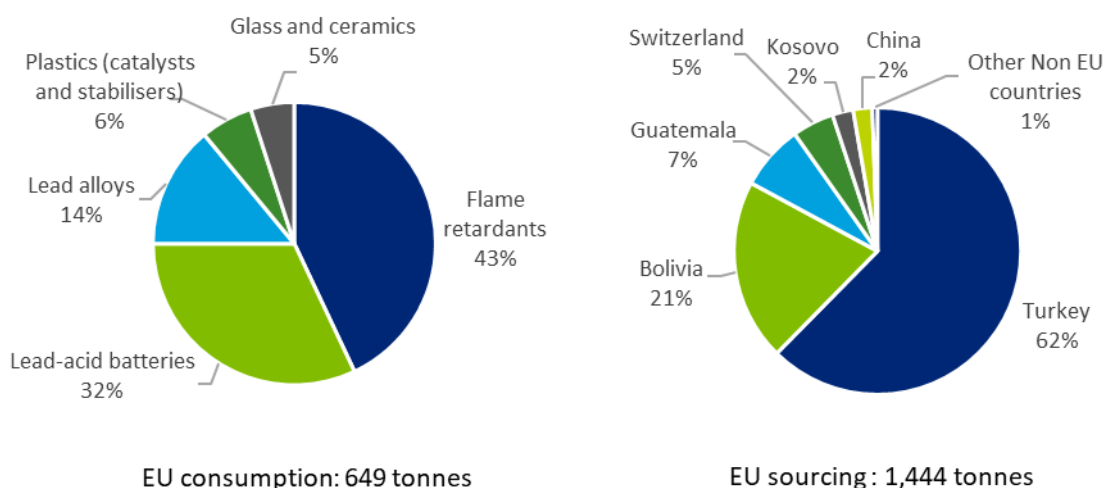
# 1 ANTIMONY

## 1.1 Overview



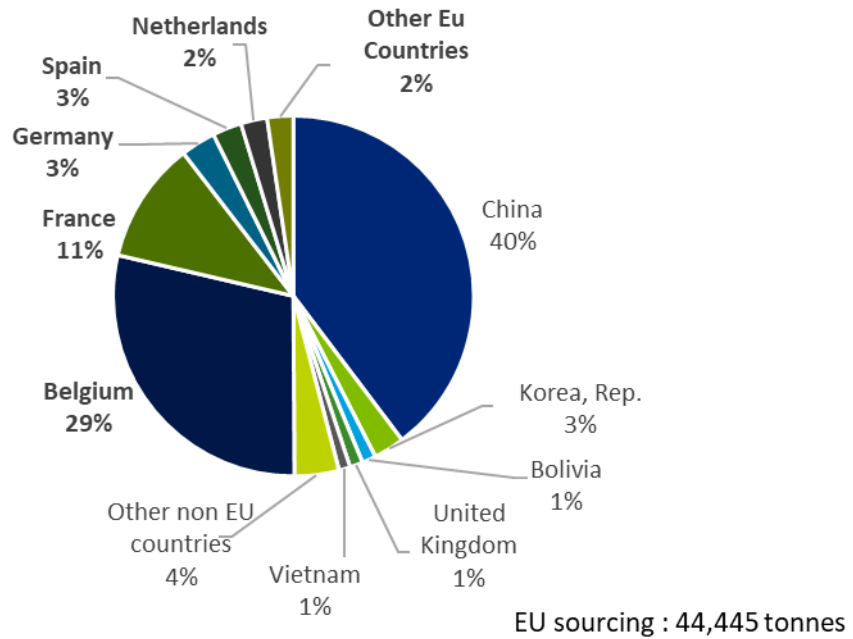
**Figure 1: Simplified value chain for antimony for the EU, averaged over 2012-2016 <sup>1</sup>**

Antimony (chemical symbol Sb) is a soft, lustrous, silver-grey metalloid. It is stable in air at room temperature, but reacts with oxygen when heated to form antimony trioxide ( $Sb_2O_3$ ). It has a relatively low melting point of  $630^{\circ}C$  and a density of  $6.697\text{ g/cm}^3$ . Antimony is rare in the Earth's crust having a (upper) crustal abundance of only 0.4 ppm (Rudnick and Gao, 2003). Antimony is found in over 100 different mineral species, typically in association with elements such as mercury, silver and gold. The principal ore mineral of antimony is stibnite ( $Sb_2S_3$ ). Antimony was on the EU's lists of critical raw materials in 2011, 2014 and 2017.



**Figure 2: End uses of antimony in the EU and EU sourcing of antimony ores and concentrates (2012-2016) (Eurostat, 2019a)**

<sup>1</sup> JRC elaboration from multiple sources (see next sections). The orange boxes of the extraction and processing stages suggest that activities are not undertaken within the EU.



**Figure 3: EU sourcing of unwrought antimony and antimony oxides (processing stage) (annual average for 2012-2016)<sup>2</sup>**

For the purpose of this assessment antimony is analysed at both extraction and processing stage. At mine stage, antimony is assessed as antimony ores and concentrates (trade code CN26171000) and at processing stage in the form of antimony wrought and powders (trade code CN811010) and antimony oxide (trade code CN282580).

The antimony market size was reported at USD 1.77 billion in 2018 and is projected to reach USD 2.37 billion by 2023, at a CAGR of 6% between 2018 and 2023. The application of antimony in the chemical industry is projected to drive the antimony market (Marketwatch Press Release, 2019). The majority of antimony is traded on annual contracts and only small amounts are sold on the open market. According to the information from USGS, antimony prices have decreased drastically in the period 2012-2016, from USD 12,445 per tonne in 2012 to USD 7,385 per tonne in 2016.

The EU is a net importer of antimony ores and concentrates. The average annual EU consumption of antimony ores and concentrates was approximately 649 tonnes per year for the period 2012-2016, supplied exclusively by import, predominantly from Turkey (62%), Bolivia (20%), and Guatemala (7%).

The EU is a major global producer of antimony oxide for the period 2012-2016. EU production of antimony oxide depends on EU imports of unwrought antimony. Between 2012 and 2016, the apparent consumption of unwrought antimony and powder and antimony oxide in the EU averaged 39,300 tonnes per year (Sb content). The EU imported antimony metal and antimony oxides with an average (2012-2016) of 22,200 tonnes per year. The EU import originated mainly from China, with annual import of 17,650 tonnes, accounting for 40% of the total EU sourcing.

Antimony is mainly used as flame retardant. It is also used as lead alloy, in lead-acid batteries, as catalyst and stabiliser in plastics manufacture, and in glass and ceramics. Antimony is harder to substitute as retardant than in other applications.

World antimony resources have been estimated at 5 million tonnes in 2011 (Bio Intelligence Service, 2015). Principal identified world resources are located in Australia,

<sup>2</sup> JRC elaboration from multiple sources. See EU demand section.

Bolivia, China, Mexico, Russia, South Africa, and Tajikistan (USGS, 2019). Additional antimony resources may occur in the Eastern United States (USGS, 2019). In Europe six countries are known to have antimony resources, including: France, Germany, Sweden, Finland, Slovakia and Greece. Most resources in Europe are based on historic estimates and are of little current economic interest.

According to the USGS, world antimony reserves amount to 1.5 million tonnes and are concentrated in China (48%), Russia (18%) and Bolivia (16%).

During the period 2012-2016, the world annual production of antimony ores and concentrates reached about 162 kt (WMD, 2019). China was the largest supplier of antimony ores and concentrates, producing 119 kt (74% of the global production). There is no reported EU production of antimony ores and concentrates in 2012-2016 (WMD, 2019).

At processing stage, the average annual quantity of unwrought antimony and powders and antimony oxides traded globally for the period 2012-2016 was 110 kt (Sb content). The main producer of antimony wrought and powders and antimony oxide during this period was China (59% of exported quantity) (UNComtrade, 2019).

The global end-of-life (EoL) recycling rate for antimony is estimated to be between 1 and 10% (UNEP, 2013). However, the Material Systems Analysis (MSA) study on antimony, undertaken by BIO by Deloitte in 2015, suggests that the EoL recycling rate for antimony in the EU is as high as 28% (BIO by Deloitte, 2015), mostly by recovery from lead-acid batteries.

The government of China set export quotas of 54.4 kt (metal content) of antimony metal and antimony trioxide in 2016 (USGS, 2016, OECD, 2019). At the beginning of 2017, the Ministry of Commerce of China lifted the export quota and introduced an export license system. Among the suppliers of antimony to the EU, a trade agreement is in place with Turkey.

A range of antimony-bearing substances falls within the EU's Regulation on the Registration, Evaluation, Authorisation and Restriction of Chemicals (REACH) which came into force in 2007 albeit with a phased implementation.

## **1.2 Market analysis, trade and prices**

---

### **1.2.1 Global market analysis and outlook**

The qualitative forecast of supply and demand of antimony is presented in Table 1. As halogenated antimony trioxide is still highly regarded as an effective flame retardant, this is likely to remain the principal market for antimony in the EU. The continued use of antimony-tin oxide (ATO) in flame retardants is also likely to be driven by increasingly stringent fire regulations. The use of antimony in lead-acid batteries is estimated to decrease (Goovaerts, 2019), as various producers substituted antimony in this application on environmental grounds in many developing nations (Schwarz-Schampera, 2014). The main substitute for antimony in lead-acid batteries is tin alloy with lead content, although this practice may not happen immediately.

Global consumption of antimony is expected to increase from 2015 to 2020, primarily in the use applications: flame retardants, lead-acid batteries, and plastics. Asia is projected to remain the leading region regarding consumption, accounting for about 60% of global consumption by 2020 (USGS, 2016).

China was the leading global producer of antimony ores and concentrates and antimony metal and oxides in 2012 to 2016. The ore and concentrates production in China

experienced a decline in 2015 due to temporary mine closures and curtailments and environmental restrictions. Antimony mining in the Guizhou Province, one of the main antimony-producing areas, was expected to be limited from 2018 as a part of the Chinese Government's mining industry reforms aiming to reduce mine overproduction (USGS, 2019).

The government of China reduced its export quotas on antimony metal and antimony trioxide from 59,400 tonnes in 2015 to 54,400 tonnes (antimony content) in 2016 (USGS, 2016, OECD, 2019). At the beginning of 2017, the Ministry of Commerce of China lifted the export quota for antimony and introduced an export license system instead.

In the fall of 2017, as prices of antimony recovered from a general declining trend in 2011-2015, and after a series of anti-pollution checks, some private sector antimony producers in China began to re-open (USGS, 2018). Several new antimony mines were also reported to have been opened outside China. For example, in 2018, one company in the United States announced the re-opening of two of its mines in Mexico (USGS, 2019).

A new antimony plant in Oman was planned to operate in 2019. The plant was set up to treat 40,000 tonnes per year of antimony-gold concentrates to produce 20,000 tonnes per year of antimony metal and antimony trioxide, making it the largest antimony roaster outside of China (Roskill General News, 2019). Nevertheless, according to experts, most of the conversion of antimony ores into antimony metal or antimony trioxide would still takes place in China (Goovaerts, 2019).

**Table 1: Qualitative forecast of supply and demand of antimony (European Commission, 2017)**

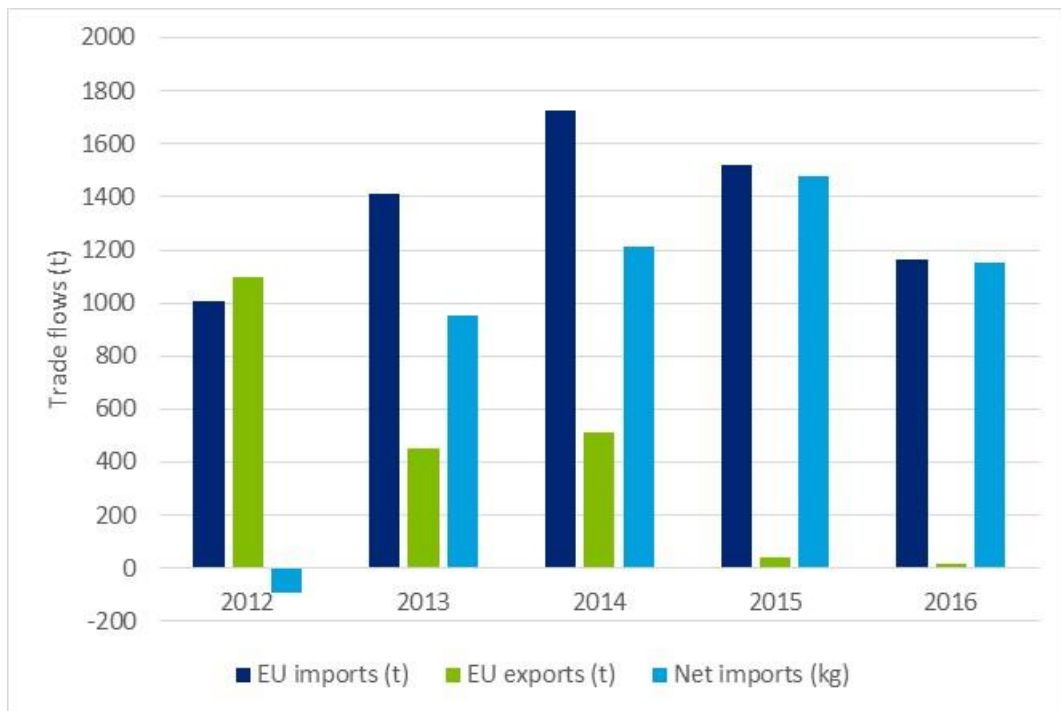
Materials	Criticality of the material in 2020		Demand forecast			Supply forecast		
	Yes	No	5 years	10 years	20 years	5 years	10 years	20 years
Antimony	X		+	+	+	+	+	+

### 1.2.1.1 EU trade

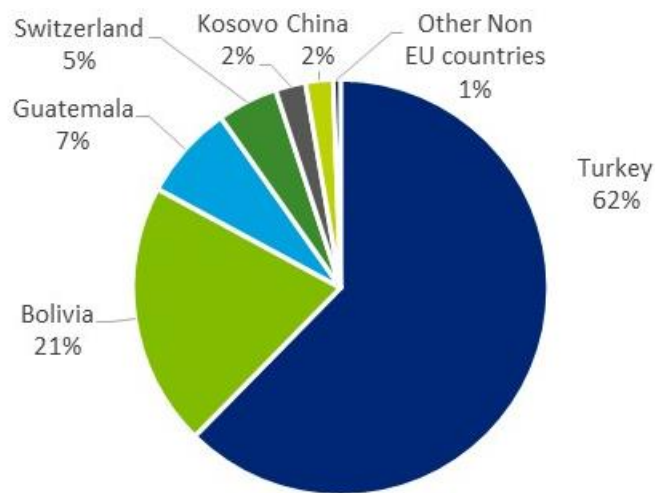
Antimony is traded in a number of forms, e.g. ores and concentrates, antimony trioxide (ATO), unwrought antimony metal and powders, scrap.

The trend of EU imports and exports of antimony ores and concentrates are presented in Figure 4. The EU is a net importer of antimony ores and concentrates with 100% of import reliance. The EU imports over the period 2012-2016 was on average 1,444 tonnes per year (Eurostat, 2019). The main suppliers of antimony ores and concentrates to the EU are Turkey (62%), Bolivia (20%), and Guatemala (7%) (Figure 5). The annual EU exports of antimony ores and concentrates in 2012-2016 was reported at 569 tonnes, i.e. less than half of the EU imports.

China, by far the biggest global producer of antimony ores and concentrates imposed an export tax on antimony ores and concentrates: 20% on CN26171010 "Crude antimony antimony concentrates which are mineral products" and 10% on 26171090 "antimony ores and concentrates: other". The share of the imports of antimony ores and concentrates from China to the total EU supply was 2% (Figure 5).



**Figure 4: EU trade flows for antimony ores and concentrates, 2012-2016. (Eurostat, 2019a)**

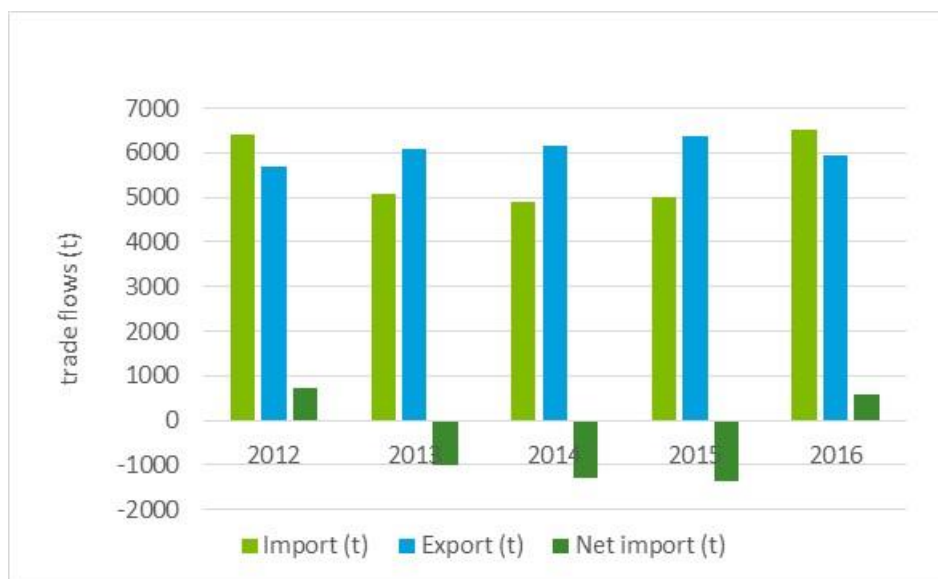


EU import : 1,444 tonnes

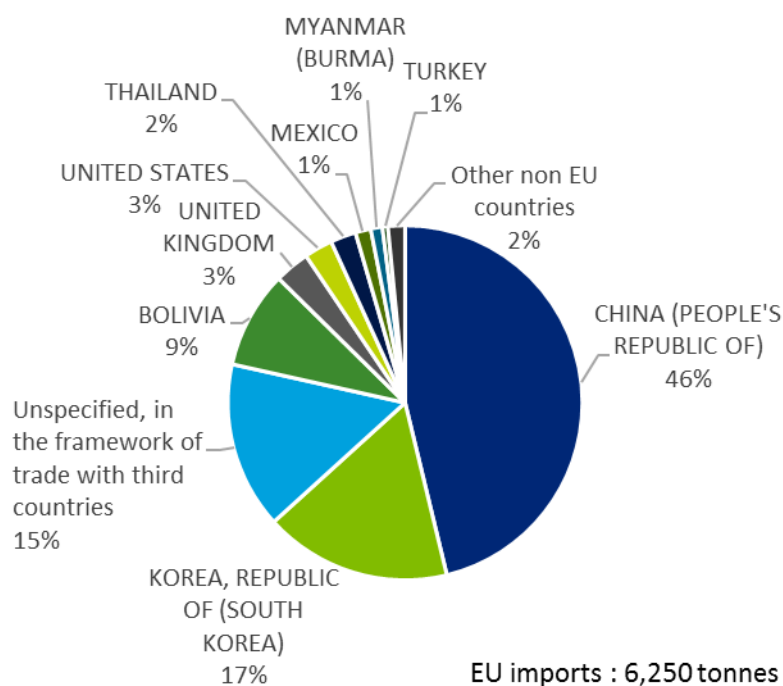
**Figure 5: EU imports of antimony ores and concentrates, average 2012-2016 (Eurostat, 2019a)**



The EU trade of antimony trioxide is shown in Figure 6. The EU is one of the most significant global exporters of antimony trioxide. In general, there was an increase in the EU export and a decreasing trend in the import of antimony trioxide between 2012 and 2015.

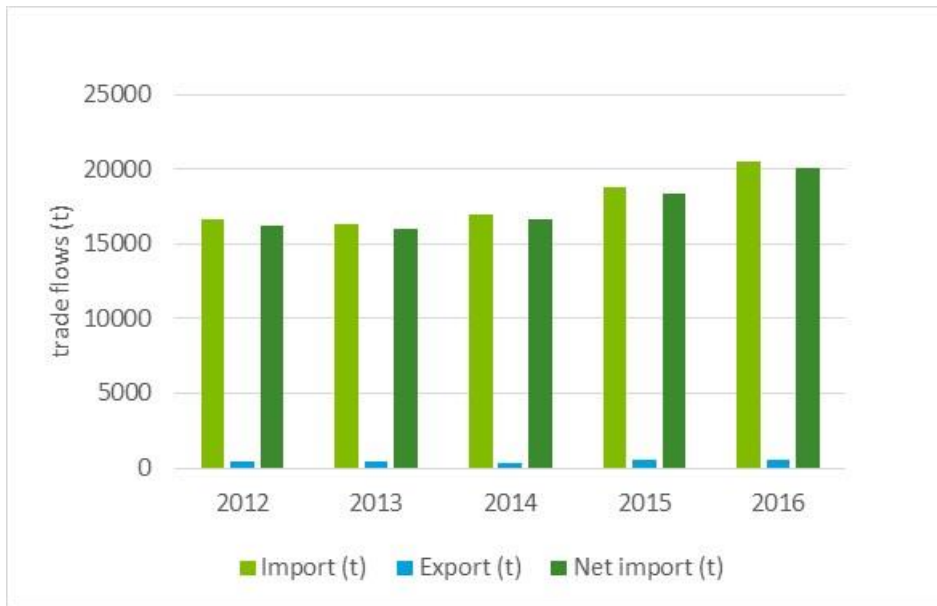


**Figure 6: EU trade flows for antimony oxide (CN 282580, tonnes of antimony oxide) (Eurostat, 2019a)**

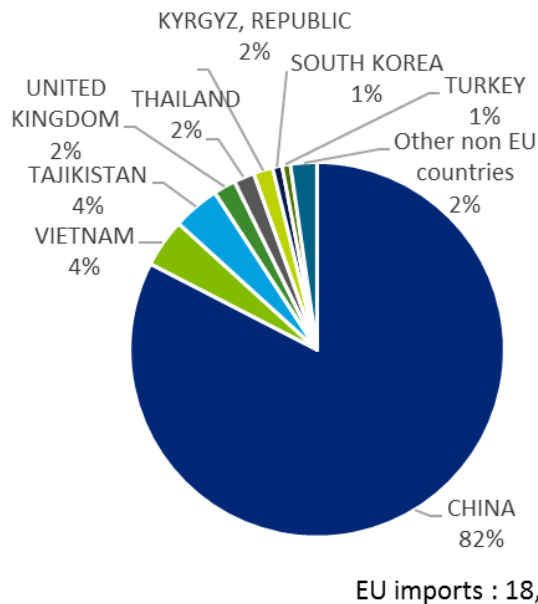


**Figure 7: EU imports of antimony oxides, average 2012-2016 (Eurostat, 2019a)**

The EU relies on import of antimony in unwrought and powder form for the production of antimony trioxide. The low export in comparison to the import suggests that most of the imported antimony unwrought and powder was consumed domestically (Figure 8). China supplied most of EU's demand of unwrought antimony and powder over the year 2012-2016, accounting for more than 80% of EU imports (Figure 9).



**Figure 8: EU trade flows for antimony unwrought and powder (CN code 811010) (Eurostat, 2019a)**



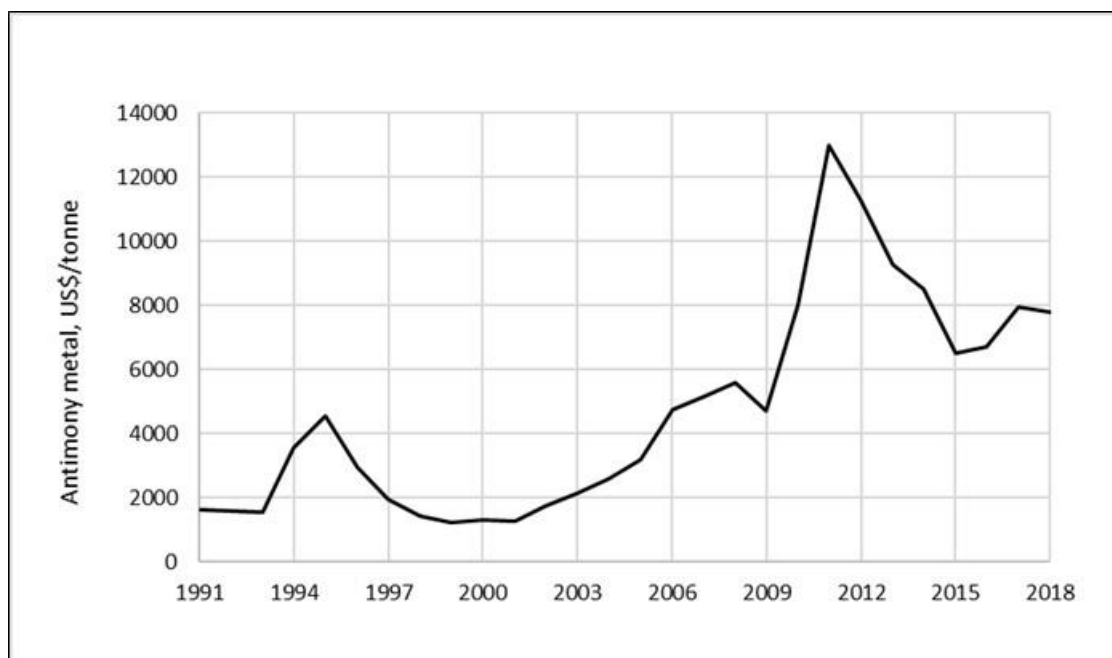
**Figure 9: EU imports of antimony unwrought and powder, average 2012-2016 (Eurostat, 2019a)**

### 1.2.1.2 Prices and price volatility

Antimony is traded in a number of forms such as ores and concentrates, antimony trioxide (ATO), unwrought antimony metal and powders, and scrap.

Figure 10 shows the price trend of antimony metal from 1991-2018 based on New York dealer prices. The price of antimony reached its peak of more than USD 14,000 per tonne in 2011. This uptrend occurred in response to Chinese mine closures and the introduction of Chinese export quotas (Schwarz-Schampera, 2014). The increased price of antimony also triggered the use of substitution of antimony. Antimony prices have generally declined from 2011 to 2015. Reports indicated that elevated producer stocks in China and lower-than-expected consumption in Europe contributed to the price decline (USGS, 2016).

In 2016 and 2017, in China many large-scale producers reduced production and many small-scale producers closed in response to price declines and, moreover, to the imposed stricter environmental standards from provincial and national governments. Antimony ingot prices have followed a steady decline since end-2018, with year-to-date prices down around 22% as of July 2019. Part of the decline in price has come from the growing volumes of stocks sold by Chinese large scale producers of ingot and trioxide since the end of 2018 (Roskill General News, 2019).



**Figure 10: Prices of antimony (USD per tonne) from 1991 to 2018 (Data from USGS<sup>3</sup>)**

## 1.3 EU demand

### 1.3.1 EU demand and consumption

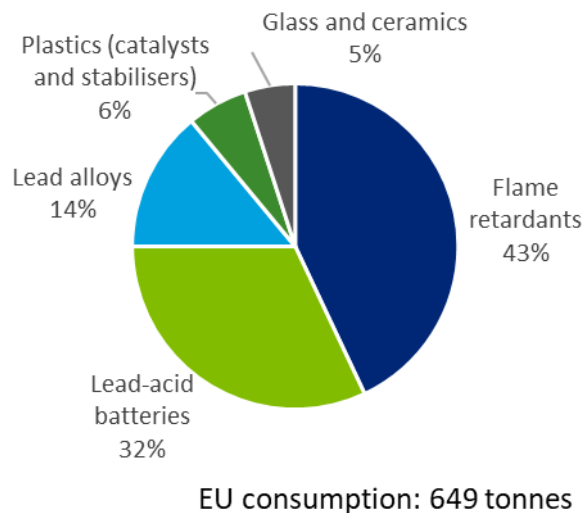
The EU is both an importer and producer of antimony trioxide. The main demand for antimony in the EU came from flame retardants (in the form of antimony trioxide) and in battery applications. The EU production of antimony trioxide also relies largely on the import of unwrought antimony metal.

The EU is a net importer of unwrought antimony metal. In the period 2012-2016, the EU imported 18,500 tonnes per year of unwrought antimony metal. The supply of unwrought antimony for the EU came mainly from China (83%), Vietnam (4%), and Tajikistan (4%).

### 1.3.2 Uses and end-uses of antimony in the EU

Figure 11 presents the main uses of antimony in the EU from 2012 to 2016.

<sup>3</sup> <https://www.usgs.gov/centers/nmic/antimony-statistics-and-information>



**Figure 11: EU end uses of antimony. Average EU import figures of antimony ores and concentrates for 2012-2016 (SCREEN, 2019).**

Approximately 43% of antimony (in the form of antimony trioxide, or ATO) is used in the production of flame retardants. Antimony trioxide is not a flame retardant in itself but it is combined with halogenated (i.e. brominated or chlorinated) flame retardant compounds. Halogenated antimony compounds are effective dehydrating agents, which inhibit ignition and pyrolysis in solids, liquids and gases. They also promote the formation of a char-rich layer on the substrate, which reduces oxygen availability and volatile-gas formation (Schwarz-Schampera, 2014). Antimony-based flame retardants are used in plastics, cable coatings, upholstered furniture, car seats, fabrics and household appliances (i2a, 2014).

Another important use of antimony, accounting for about 32% of global antimony consumption, is the production of antimonial or hard-lead alloys used in the manufacture of lead-acid batteries. The incorporation of 1-15 % antimony in these alloys improves tensile strength and thus charging characteristics. Further, it also prevents the production of unwanted hydrogen during charging. Antimony-lead alloys that contain 1-3% antimony are easy to cast and are used in the production of grid plates, straps and terminals in lead-acid batteries (Schwarz-Schampera, 2014; CRM\_InnoNet, 2015).

The production of lead alloys accounts for about 14% of the global antimony use. Examples for this application are in the manufacture of low-load bearings used in the automotive sector, as well as in the manufacture of household and decorative items such as teapots, vases and lamp stands. Tin-lead-antimony solders are used extensively in the electronics industry (Schwarz-Schampera, 2014; CRM\_InnoNet, 2015).

About 6% of antimony, in the form of antimony trioxide (ATO), is used as a catalyst in the production of polyethylene terephthalate (PET). PET is one of the key input materials for the manufacture of plastic bottles, also for water and food bottles. ATO is also used as a heat stabiliser in polyvinyl chloride (PVC) (Schwarz-Schampera, 2014).

Antimony in the form of sodium hexahydroxyantimonate, is used in the manufacture of high-quality clear glass. This use accounts for about 5% of the global antimony consumption. In this particular application, antimonates are primarily used as degassing agents, which act to remove trapped air bubbles from the cooling glass. They also act as

a fining agent for removing impurities (e.g. iron) that may produce unwanted colouration (Schwarz-Schampera, 2014).

Other minor uses of antimony (accounting for less than 1% of the EU demand) are (Braibant, 2019):

- Functional pigments used in plastics, rubber, paints and enamels (mainly Sb oxides and sulfides)
- Lubricants used in brake pads and disk clutches (mainly Sb trisulfide)
- Ammunition primer in blasting caps, ignition agents and smoking agents (mainly Sb trisulfide)
- Catalysts for oil refining (mainly Sb oxides)
- Medical treatment of leishmaniosis (mainly pentavalent Sb species)

Antimony-compounds are used also as cross-linking catalyst and stabilizers in explosive formulation, serving a function similar to catalysts and stabilizers (Castresana-Pelayo, 2019).

Relevant industry sectors are described using the NACE sector codes (Eurostat, 2016c), presented in Table 2.

**Table 2: Antimony applications, 2-digit and associated 6-digit CPA sectors, and value added per sector (Based on value added from Eurostat, 2019b)**

Applications	2-digit NACE sector	Value added per sector	4-digit CPA
Flame retardants	C20 - Manufacture of chemicals and chemical products	105,514	C2059 - Manufacture of other chemical products n.e.c.
Lead-acid batteries	C27 - Manufacture of electrical equipment	80,745	C2720 - Manufacture of batteries and accumulators
Lead alloys	C25 - Manufacture of fabricated metal products, except machinery and equipment	148,351	C2599 - Manufacture of other fabricated metal products n.e.c.
Plastics (catalysts and stabilisers)	C20 - Manufacture of chemicals and chemical products	105,514	C2016 - Manufacture of plastic in primary forms
Glass and ceramics	C23 - Manufacture of other non-metallic mineral products	57,255	C2311 - Manufacture of flat glass

### 1.3.3 Substitution

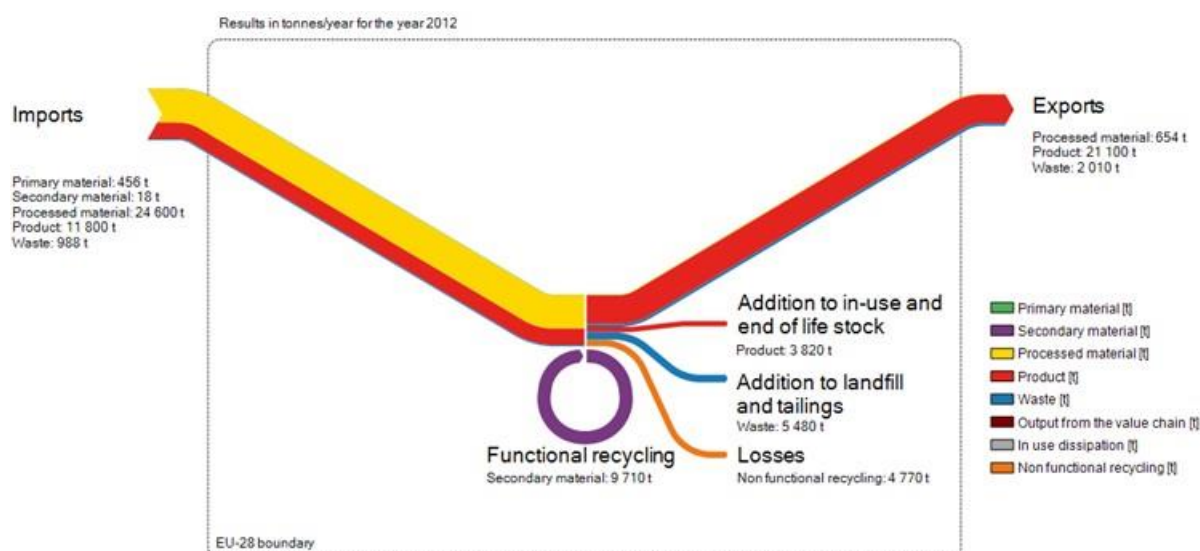
Substitution of antimony remains similar to with what was described at the critical raw material assessment in 2017. Antimony is reasonably easy to substitute in some of its applications (CRM\_InnoNet, 2015). For example, compounds of chromium, tin, titanium, zinc and zirconium can substitute for antimony in the manufacture of pigments and glass. However, in its main application (i.e. as a flame retardant) antimony is much harder to substitute. Compounds such as alumina trihydrate, magnesium hydroxide and zinc borate may partially substitute for antimony in flame-retardant materials. However, their performance is inferior to antimony-based flame retardants.

Various combinations of cadmium, barium, calcium, lead, tin, zinc and germanium may substitute for antimony in the production of plastics (e.g. as stabilisers or catalysts), but this option is commonly more expensive. There are several metals that may substitute for antimony in the production of lead alloys (e.g. cadmium, calcium, selenium, tin and copper). However, assuming 1:1 substitution in alloys is overly simplistic, for the simple reason that the properties of a given alloy are not controlled by a single metal, but rather by the combination of several metals, where each metal may produce a range of effects in the alloy (Schwarz-Schampera, 2014) (CRM\_InnoNet, 2015). Accordingly, any substitution would be associated with a price and/or performance penalty. In general there appears to be little economic or technical incentive to substitute antimony in its principal applications.

## 1.4 Supply

### 1.4.1 EU supply chain

The flows of antimony through the EU economy are demonstrated in Figure 12.

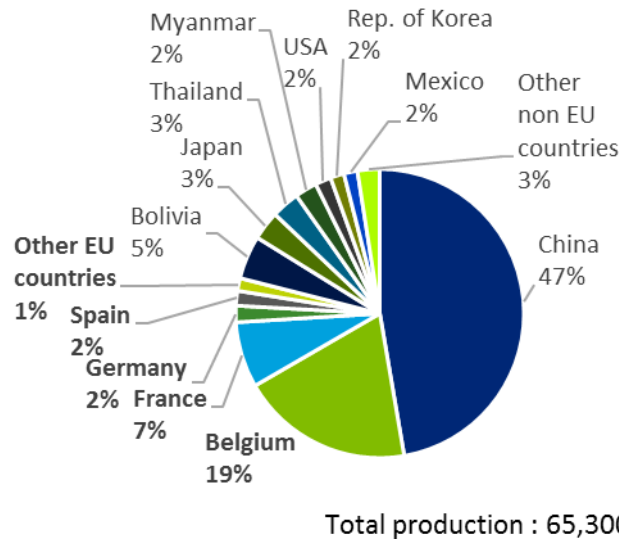


**Figure 12: Material System Analysis of antimony in 2012, EU-28 (Bio Intelligence Service, 2015)**

The extraction of antimony ores and the production of antimony concentrates does not occur in the EU. The EU is a net importer of antimony ores and concentrates with an import reliance of 100%.

At processing stage, it is difficult to quantify the volume of antimony trioxide produced in EU because such data are unavailable in the Eurostat Prodcom database. For this reason, antimony oxide trade figures from the UNComtrade were used as proxy as production data. Based on the quantity of antimony trioxide traded globally in the period 2012-2016, the EU countries, together with China, were among the most important exporters of antimony trioxide. The EU export of antimony trioxide accounted for more than 30% of the average global exports for the period 2012-2016.

However, for the production of antimony trioxide, the EU relies on import of antimony in unwrought and powder form.



**Figure 13: Global production of antimony trioxide, average 2012-2016 (UN Comtrade, 2019)**

## 1.4.2 Supply from primary materials

### 1.4.2.1 Geology, resources and reserves of antimony

#### Geological occurrence:

The most important antimony deposits, based on their antimony content, include: (1) greenstone-hosted quartz-carbonate veins and carbonate replacement deposits; (2) gold-antimony (epithermal) deposits; and (3) reduced magmatic gold systems. In many of these deposits, stibnite ( $Sb_2S_3$ ) is the principal ore mineral (Schwarz-Schampera, 2014).

Greenstone-hosted antimony deposits are of particular economically importance. They are estimated to tens of millions of tonnes in size and typically contain between 1.5 and 25%  $Sb_2S_3$ . These deposits typically comprise a stockwork of gold-antimony-quartz-carbonate veins hosted by metavolcanic and/or metasedimentary rocks. Carbonate replacement deposits are also found in some of these metasedimentary sequences (e.g. Xikuangshan, China), which are thought to form by hydrothermal alteration of the host material (Schwarz-Schampera, 2014).

Epithermal gold-antimony deposits are generally smaller than greenstone-hosted deposits. They are typically up to 1 million tonnes in size, and have lower ore grades (up to 3.5%  $Sb_2S_3$ ). The formation of these epithermal deposits is linked to the emplacement of magmatic porphyry copper systems in the shallow crust (upper 1.5 km). The mineralisation generally takes the form of veins, or disseminations of stibnite and/or tetrahedrite ( $(Cu,Fe)_{12}Sb_4S_{13}$ ) in the host rocks (Schwarz-Schampera, 2014).

Reduced magmatic gold systems are associated with the intrusion of metaluminous granite plutons, the mineralisation taking the form of quartz-carbonate sheeted veins, replacement bodies and/or skarns. The mineralisation may be enriched in several metals, including gold, tellurium, tungsten, arsenic and antimony. These deposits are similar in size to the greenstone-hosted antimony deposits, but have typically much lower grades (0.1 to 1.5%  $Sb_2S_3$ ) (Schwarz-Schampera, 2014).

### Global resources and reserves<sup>4</sup>:

Identified principal world resources of antimony are located in Australia, Bolivia, China, Mexico, Russia, South Africa, Turkey and Tajikistan. Additional antimony resources may occur in the Eastern United States (USGS, 2019).

USGS listed countries and the quantity of reserves of antimony (Table 3). The reserves originating from these countries were approximately 1.5 million tonnes of contained antimony (USGS, 2019). Apart from the countries listed in Table 3, reserves are known to exist in Myanmar, Guatemala, Iran, Kazakhstan, Laos, Pakistan, and Vietnam but there was no data on the quantity.

**Table 3: Global reserves of antimony in year 2019 (Data from USGS, 2019).**

Country	Antimony Reserves (tonnes of antimony content)
United States	60,000
Australia	140,000
Bolivia	310,000
China	480,000
Mexico	18,000
Russia (recoverable)	350,000
Tajikistan	50,000
Turkey	100,000

### EU resources and reserves<sup>5</sup>:

In Europe six countries are known to have antimony resources: France, Germany, Sweden, Finland, Slovakia and Greece (Minerals4EU, 2019). Most resource figures in Europe are based on historic estimates and thus not reported in accordance with the UNFC system of reporting. These resources are currently considered to be of little economic interest. Data for Germany are not reported because data collection in that country is under the responsibility of authorities at federal state level (Minerals4EU, 2019). Resource data for

---

<sup>4</sup> There is no single source of comprehensive evaluations for resources and reserves that apply the same criteria to deposits of antimony in different geographic areas of the EU or globally. The USGS collects information about the quantity and quality of mineral resources but does not directly measure reserves, and companies or governments do not directly report reserves to the USGS. Individual companies may publish regular mineral resource and reserve reports, but reporting is done using a variety of systems of reporting depending on the location of their operation, their corporate identity and stock market requirements. Translations between national reporting codes are possible by application of the CRIRSCO template.<sup>4</sup>, which is also consistent with the United Nations Framework Classification (UNFC) system. However, reserve and resource data are changing continuously as exploration and mining proceed and are thus influenced by market conditions and should be followed continuously.

<sup>5</sup> For Europe, there is no complete and harmonised dataset that presents total EU resource and reserve estimates for antimony. The Minerals4EU project is the only EU-level repository of some mineral resource and reserve data for antimony, but this information does not provide a complete picture for Europe. It includes estimates based on a variety of reporting codes used by different countries, and different types of non-comparable datasets (e.g. historic estimates, inferred reserves figures only, etc.). In addition, translations of Minerals4EU data by application of the CRIRSCO template is not always possible, meaning that not all resource and reserve data for antimony the national/regional level is consistent with the United Nations Framework Classification (UNFC) system (Minerals4EU 2019). Many documented resources in Europe are based on historic estimates and are of little current economic interest. Data for these may not always be presentable in accordance with the UNFC system. However a very solid estimation can be done by experts.



some countries in Europe are available on the Minerals4EU (2019) website (see Table 4) but cannot be summed as they are partial and they do not use the same reporting code.

Other than the resource estimation reported on Minerals4EU website, deposit of antimony was reported in Rockliden, Sweden at 10 Mt with 0.18% Sb, (also contains 4.03% Zn, 1.82% Cu, 52 ppm Ag, 0.06 ppm Au) (Depauw, G., 2019).

In addition, antimony occurrences were also reported to exist in Austria, Bulgaria, Czechia, Hungary, Italy, Luxembourg, Portugal, Romania, Slovenia, and Spain (Lauri et al., 2018).

Austria was reported to have several deposits or occurrences and past production of antimony as either main commodity or by-product. The ProMine database estimated about 20,000 tonnes of Sb reserves and resources for Italy, of which 400 tonnes of antimony was at Su Suergiu deposit in Sardinia (Lauri et al., 2018). No information on resources were available concerning occurrences of antimony in Czechia, Hungary, Romania, and Slovenia.

In Portugal, antimony was mined until 1967, when the Barroca da Mina/Barroca da Santa mine was closed. Portuguese deposits were estimated to have 17,700 tonnes of remaining resources of of antimony (Lauri et al., 2018).

In Bulgaria, an exploration activity for gold-antimony deposits took place in 2017. According to the reported exploration license, the estimated total endowment of antimony from these deposits was 124,000 tonnes.

**Table 4: Resource data for the EU compiled in the European Minerals Yearbook of the Minerals4EU website (Minerals4EU, 2019)**

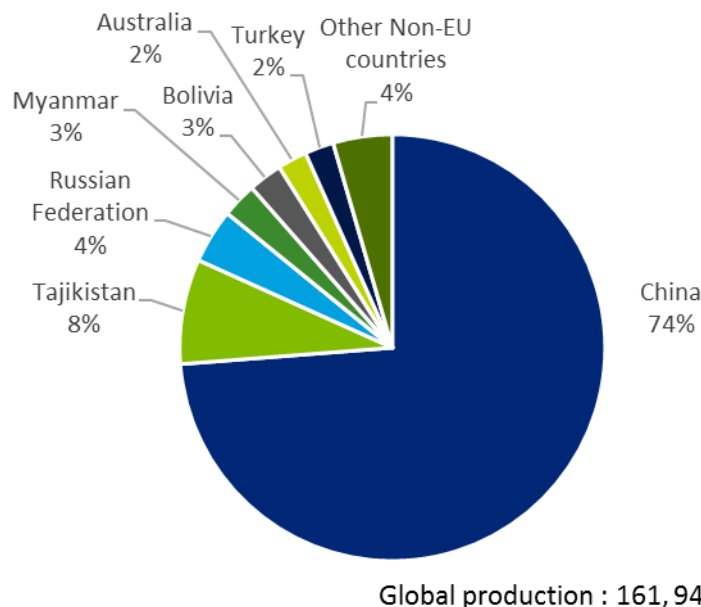
Country	Reporting code	Quantity	Unit	Grade	Code Resource Type
France	None	26,250	t	Metal content	Historic Resource Estimates
Greece	UGSG	90	kt	2.5%	Indicated
Slovakia	None	3.206	Mt	1.71% sub-economic	-
Finland	none	0.3	Mt	0.41%	Historic Resource Estimates
Sweden	Historic	17	Mt	0.06%	Historic Resource Estimates

#### 1.4.2.2 World and EU mine production

During the period 2012-2016, the world annual production of antimony ores and concentrates reached about 162,000 tonnes per year. China was the largest supplier of antimony ores and concentrates, producing 119,000 tonnes or approximately 74% of the global production. Tajikistan followed behind China with an annual production of 12,900 tonnes, constituting 8% of the global production. Russia, Myanmar, and Bolivia were the third, fourth, and fifth biggest global producers of antimony ores and concentrates during the period 2012-2016, producing in total 10% of world production of ores and concentrates (WMD, 2019). There is no EU production of antimony (WMD, 2019) (Figure 14).

In 2016, several new antimony mine projects were being evaluated and developed in Armenia, Australia, Burma, Canada, China, Georgia, Italy, Laos, Russia, South Africa, and Turkey. In Oman, a producer announced plans to construct an antimony smelter that would have the capacity to produce 20,000 tonnes per year of antimony metal and oxide (Roskill General News, 2019). The Omani antimony project would be the largest antimony roaster outside of China. In 2018, a company in the United States announced the re-opening of two of its mines in Mexico (USGS, 2019). In the next several years after 2018,

antimony mining in the Guizhou Province was expected to be limited as a part of the Chinese Government’s mining industry reforms aiming to reduce mine overproduction (USGS, 2019).



**Figure 14: Global mine production of antimony. Average for the years 2012-2016. (WMD, 2019)**

### 1.4.3 Supply from secondary materials/recycling

Secondary antimony can be found in two main types of sources: in waste from processing antimony bearing materials as well as in end of life products from urban mines and manufacturing residues (Sundqvist Oeqvist, Pr. Lena et al., 2018).

The global end-of-life (EoL) recycling rate for antimony is estimated to be between 1 and 10% (UNEP, 2013). The Raw Materials Supply Assessment (RMSA) study, undertaken by BIO by Deloitte in 2015, suggests that the EoL recycling rate in the EU for antimony is as high as 28% (BIO by Deloitte, 2015). Secondary antimony is chiefly recovered from lead-acid batteries. Therefore, the availability of secondary antimony is almost entirely dependent on the extent of lead recycling and the market conditions for lead and lead-acid battery scrap. Since the supply of primary antimony is heavily concentrated in a few countries, the recovery of secondary antimony is an important part of the supply chain in countries like, for example, the United States, Japan, Canada and the EU. On a global scale, it was estimated, that in 2010 the secondary production of antimony accounted for about 20% of total antimony supply (Sundqvist Oeqvist, Pr. Lena et al., 2018).

In the EU, there are companies dealing with secondary antimony. Umicore is a company headquartered in Belgium, which recovers antimony from end-of-life batteries, mostly from electric cars. Solvay in France recycles halophosphate from spent fluorescent batteries (Sundqvist Oeqvist, Pr. Lena et al., 2018).

Antimony used in the manufacture of plastics and flame retardants is generally not recovered because antimony is dispersed in these products (Schwarz-Schampera, 2014). However, antimony could potentially be recovered from the bottom ash resulting from the incineration of some of these products at their end-of-life stage, but this currently does not appear to be economically viable (BraibantC., 2017).

**Table 5: Material flows relevant to the EOL-RIR of antimony<sup>6</sup>**

MSA Flow	Value (t)
B.1.1 Production of primary material as main product in EU sent to processing in EU	87312
B.1.2 Production of primary material as by product in EU sent to processing in EU	0
C.1.3 Imports to EU of primary material	236303
C.1.4 Imports to EU of secondary material	0
D.1.3 Imports to EU of processed material	81142
E.1.6 Products at end of life in EU collected for treatment	130813
F.1.1 Exports from EU of manufactured products at end-of-life	193
F.1.2 Imports to EU of manufactured products at end-of-life	2847
G.1.1 Production of secondary material from post consumer functional recycling in EU sent to processing in EU	0
G.1.2 Production of secondary material from post consumer functional recycling in EU sent to manufacture in EU	4861

#### 1.4.4 Processing of Antimony

There is no official data on the global production of antimony products. Based on the estimation from the global trade data, the quantity of antimony contained in antimony wrought and powders supplied to the market in the period 2012-2016 was 45,700 tonnes per year. The main suppliers of antimony wrought and powders, are China (79%) followed by Vietnam (9%) and India (4%) (Comtrade, 2019). This figure was estimated from the export figures of antimony wrought and powders from Comtrade.

However, when interpreting these trade figures, there are uncertainties about the possible "Rotterdam effect", i.e. some countries re-exports of antimony products appear misleadingly as production figures.

### 1.5 Other considerations

#### 1.5.1 Environmental and health and safety issues

A range of antimony-bearing substances fall within the EU's Regulation on the Registration, Evaluation, Authorisation and Restriction of Chemicals (REACH), which came into force in 2007 albeit with a phased implementation.

#### 1.6 Comparison with previous EU assessments

The assessment has been conducted using the same methodology as for the 2017 list.

In criticality assessment 2014, supply risk of antimony was assessed at mine stage, with trade figures referring to antimony ores and concentrates. At the CRM assessment 2017, the supply risk of antimony was assessed only at processing stage, focusing on unwrought antimony, which was considered a bottleneck for the EU supply. Since there was no data on global supply of unwrought antimony, the trade data (UN Comtrade) for unwrought antimony was used as a proxy of production capacity. The figure of unwrought antimony exported from the EU, however, was omitted from the global picture of production capacity, since the EU relied 100% on imports of antimony ores and concentrates as raw materials. This consideration was reflected on the high supply risk value in CRM 2017. In criticality assessment 2020, supply risk of antimony was calculated at both mine stage and refined stage. Following the input from experts, in criticality assessment 2020, supply

<sup>6</sup> EOL-RIR=(G.1.1+G.1.2)/(B.1.1+B.1.2+C.1.3+D.1.3+C.1.4+G.1.1+G.1.2)

risk of refined antimony was assessed for the sum of unwrought antimony and antimony oxides. The assessment also took into account the EU production capacity (Braibant, C., 2019). The taken approach resulted in a lower supply risk value at refined stage since the global supply is less concentrated and the EU has a production capacity. The supply risk value for antimony is higher at mine stage, the stage where the EU has no production and therefore relies 100% on imports from extra-EU countries. Therefore, the supply risk figure reported in Table 6 refers to mine stage.

The economic importance of antimony showed a higher value in comparison with criticality assessment 000000000000000000002017, while the end uses in the EU remained the same. The increase economic importance parameter in 2020 can be explained by the change in the value added of the sectors for which antimony is assigned.

The results of the current criticality assessment and earlier assessments are shown in Table 6.

**Table 6: Economic importance and supply risk results for antimony in the assessments of 2011, 2014, 2017, 2020 (European Commission, 2011; European Commission, 2014; European Commission, 2017)**

Assessment	2011		2014		2017		2020	
	EI	SR	EI	SR	EI	SR	EI	SR
Antimony	5.84	2.56	7.07	2.54	4.3	4.3	4.77	2.01

## 1.7 Data sources

Data for the production of processed antimony (unwrought antimony and antimony oxides) are not available at global level. Therefore, the calculation of supply risk at processing stage was done using trade data from UN-Comtrade as a proxy, which is an approach that has to be carefully interpreted due to the possible 'Rotterdam effect'. In exceptional cases, certain production figures may be overestimated as re-exports might be counted as antimony production.

### 1.7.1 Data sources used in the factsheet

BGS (2016). World Mineral Production 2010-2014 [online]. Keyworth, Nottingham British Geological Survey, Available at: <http://www.bgs.ac.uk/mineralsuk/statistics/home.html>

Bio Intelligence Service (2015). Study on Data for a Raw Material System Analysis. Prepared for the European Commission, DG GROW.

Braibant, C. (2017). Personal Communication regarding antimony production and trade [February 2017].

Braibant, C. (2019). Personal Communication in view of consultation for the first result of criticality assessment 2020 [June 2019].

Castresana-Pelayo, Jose M. (2019). Personal communication.

CRM\_InnoNet. (2015). Critical raw materials substitution profiles – niobium [online]. Available at: <http://www.criticalrawmaterials.eu/>

Depauw, G. (2009). Geology of the Rockliden volcanogenic massive sulphide deposit, north central Sweden. [online]. Available at: <http://www.diva-portal.org/smash/get/diva2:1032308/FULLTEXT01.pdf>

European Commission (2010). Critical raw materials for the EU [online]. Available at: [https://ec.europa.eu/growth/sectors/raw-materials/specific-interest/critical\\_en](https://ec.europa.eu/growth/sectors/raw-materials/specific-interest/critical_en)

European Commission (EC). (2014). Report on Critical Raw Materials for the EU. Critical Raw Materials Profiles [online] Brussels European Commission. Available at: <http://ec.europa.eu/growth/sectors/raw-materials/specific-interest/critical/>\*

European Commission (2011). Critical raw materials for the EU. [online] Available at: [https://ec.europa.eu/growth/sectors/raw-materials/specific-interest/critical\\_en](https://ec.europa.eu/growth/sectors/raw-materials/specific-interest/critical_en)

European Commission (2014) Report on critical raw materials for the EU – Non Critical raw materials profiles.

Eurostat (2019)a. International Trade Easy Comext Database [online] Available at: <http://epp.eurostat.ec.europa.eu/newxtweb/>

Eurostat (2019)b. Annual detailed enterprise statistics for industry (NACE Rev. 2, B-E). [online] Available at: [http://ec.europa.eu/eurostat/en/web/products-datasets/-/SBS\\_NA\\_IND\\_R2](http://ec.europa.eu/eurostat/en/web/products-datasets/-/SBS_NA_IND_R2)

Goovaerts, Hilde (Campine) (2019). Personal communication in October 2019.

International Antimony Association (i2a). (2014). Antimony trioxide factsheet [online]. Available at: <http://www.antimony.com/en/publications.aspx>

Marketwatch Press Release (2019). The antimony market size is estimated to be USD 1.77 billion in 2018 and is projected to reach USD 2.37 billion by 2023, at a CAGR of 6.0% between 2018 and 2023 [online] Available at: <https://www.marketwatch.com/press-release/the-antimony-market-size-is-estimated-to-be-usd-177-billion-in-2018-and-is-projected-to-reach-usd-237-billion-by-2023-at-a-cagr-of-60-between-2018-and-2023-2018-07-17> access date: 12/11/2019

Minerals4EU (2019). European Minerals Yearbook [online]. Available at: [http://minerals4eu.brgm-rec.fr/m4eu-yearbook/theme\\_selection.html](http://minerals4eu.brgm-rec.fr/m4eu-yearbook/theme_selection.html)

OECD Export Restriction database, 2019 [online]. Available at: <http://www.oecd.org/tad/benefitlib/export-restrictions-raw-materials.htm>

Roskill General News (2019). Antimony: SPMP produces ingot with 98% purity from its Oman Antimony Roaster. [online] Available at: <https://roskill.com/news/antimony-spmp-produces-ingot-with-98-purity-from-its-oman-antimony-roaster/> access date 12/11/2019

Rudnick, R.L. and Gao. S. (2003). Composition of the Continental Crust. In: Treatise on Geochemistry, Volume 3. Editor: Roberta L. Rudnick. Executive Editors: Heinrich D. Holland and Karl K. Turekian. pp. 659. ISBN 0-08-043751-6. Elsevier, p.1-64.

Schwarz-Schampera, U. (2014). Antimony. In: Gunn, G. (Editor), Critical Metals Handbook, John Wiley & Sons, 70–98.

SCRREEN workshop. (2019). Validation Workshop on Critical Raw Materials, 10-12 September 2019, Thon Hotel Brussels City Centre.

Sundqvist Oeqvist, Pr. Lena et al. (2018). SCRREEN D4.2. Production Technologies of CRM from Primary Resources. Available at: <http://screen.eu/wp-content/uploads/2018/03/SCRREEN-D4.2-Production-technologies-of-CRM-from-secondary-resources.pdf>

UN Comtrade database (2019) [online]. Available at: <https://comtrade.un.org/>

UNEP. (2013). Metal Recycling - Opportunities, limits and infrastructure. A Report of the Working Group on the Global Metal Flows to the International Resource Panel [online]. Available at:

<http://www.unep.org/resourcepanel/publications/metalrecycling/tabid/106143/default.aspx>

USGS (2014). Minerals Yearbook. Antimony [online]. Available at: <https://minerals.usgs.gov/minerals/pubs/commodity/antimony/>

USGS (2016). Mineral Commodity Summary. Antimony [online]. Available at: <https://minerals.usgs.gov/minerals/pubs/commodity/antimony/>

USGS (2018). Mineral Commodity Summary. Antimony [online]. Available at: <https://minerals.usgs.gov/minerals/pubs/commodity/antimony/>

USGS (2019). Mineral Commodity Summary. Antimony [online]. Available at: <https://minerals.usgs.gov/minerals/pubs/commodity/antimony/>

WMD (2019) World Mining Data 2019, Reichl, C.; Schatz, M; Zsak, G. Iron and Ferro Alloy Metals, non Ferrous Metals, Precious Metals, Industrial Minerals, Mineral Fuels. Austrian Federal Ministry of Sustainability and Tourism. [online] Available at: [www.en.bmwf.gv.at/Energy/WorldMiningData/Seiten/default.aspx](http://www.en.bmwf.gv.at/Energy/WorldMiningData/Seiten/default.aspx)

### **1.7.2 Data sources used in the criticality assessment**

World Mining Data (2019). Bundesministerium für Nachhaltigkeit und Tourismus. Austrian Federal Ministry of Sustainability and Tourism. [online] Available at: [www.en.bmwf.gv.at/Energy/WorldMiningData/Seiten/default.aspx](http://www.en.bmwf.gv.at/Energy/WorldMiningData/Seiten/default.aspx)

Eurostat (2019)a. International Trade Easy Comext Database [online] Available at: <http://epp.eurostat.ec.europa.eu/newxtweb/>

Eurostat (2019)b. Annual detailed enterprise statistics for industry (NACE Rev. 2, B-E). [online] Available at: [http://ec.europa.eu/eurostat/en/web/products-datasets/-/SBS\\_NA\\_IND\\_R2](http://ec.europa.eu/eurostat/en/web/products-datasets/-/SBS_NA_IND_R2)

European Commission (EC). (2014). Report on Critical Raw Materials for the EU. Critical Raw Materials Profiles [online] Brussels European Commission. Available at: <http://ec.europa.eu/growth/sectors/raw-materials/specific-interest/critical/>\*

European Commission (2017) Report on critical raw materials for the EU - Critical raw materials profiles.

European Commission (2019). Free trade agreements. [online] Available at: <http://ec.europa.eu/trade/policy/countries-and-regions/agreements/>

Bio Intelligence Service (2015). Study on Data for a Raw Material System Analysis. Prepared for the European Commission, DG GROW.

Nassar, N. T., T. E. Graedel, and E. M. Harper (2015). By-Product Metals Are Technologically Essential but Have Problematic Supply. Science Advances. <https://doi.org/10.1126/sciadv.1400180>.

OECD Export Restriction database, 2019 [online]. Available at: <http://www.oecd.org/tad/benefitlib/export-restrictions-raw-materials.htm>

Tercero Espinoza, L., Hummen, T., Brunot, A., Hovestad, A., Pena Garay, I., Velte, D., Smuk, L., Todorovic, J., van der Eijk, C. and Joce, C. 2013. "Critical Raw Materials Substitution Profiles. September 2013 Revised May 2015. CRM\_InnoNet Available At:" <http://www.criticalrawmaterials.eu/wp-content/uploads/D3.3-Raw-Materials-Profiles-final-submitted-document.pdf>.

UN Comtrade database (2019) [online]. Available at: <https://comtrade.un.org/>

USGS (2019). Mineral Commodity Summary. Antimony [online]. Available at: <https://minerals.usgs.gov/minerals/pubs/commodity/antimony/>

SCRREEN workshop. (2019). Validation Workshop on Critical Raw Materials, 10-12 September 2019, Thon Hotel Brussels City Centre.

Statista. Statista, Medium-term forecast for boric acid prices worldwide from 2012 to 2023. Available at: <https://www.statista.com/statistics/449813/global-prediction-of-medium-term-boric-acid-prices/> (access date 30/01/2020)

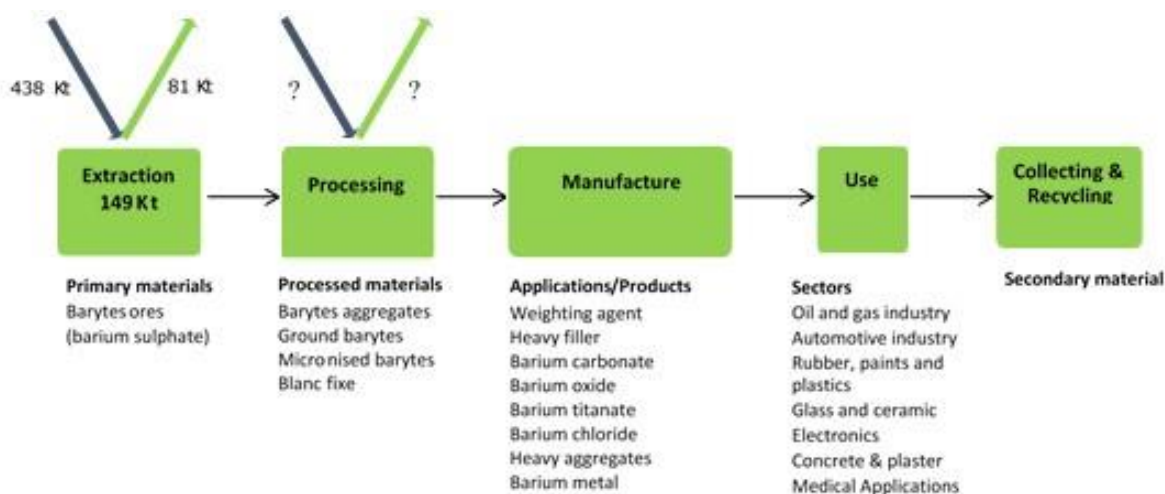
## **1.8 Acknowledgments**

---

This factsheet was prepared by the JRC. The authors would like to thank the Ad Hoc Working Group on Critical Raw Materials as well as experts participating in SCRREEN workshops for their valuable contribution and feedback, especially to CRM Alliance and Campine.

# 2 BARYTE

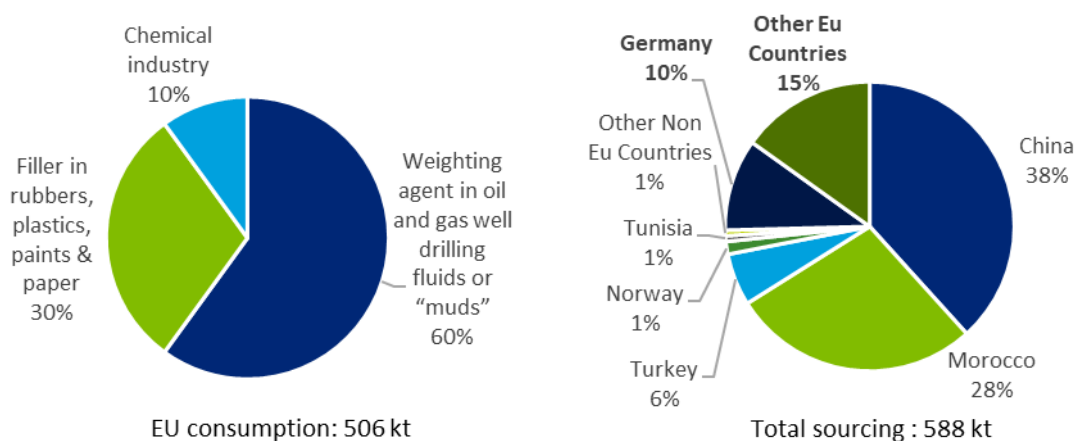
## 2.1 Overview



**Figure 15: Simplified value chain for baryte for the EU, averaged over 2012-2016<sup>7</sup>**

Baryte (or barite)(chemical symbol Ba) is a naturally occurring barium sulphate mineral ( $BaSO_4$ ). It is inert, non-toxic and almost insoluble in water. Baryte has a high density, of  $4.5 \text{ g/cm}^3$ , a high fusion point ( $1,580^\circ\text{C}$ ) and brightness, and a low oil absorption. Baryte is commonly white, or colourless, but can appear in various colours, like grey or black, depending on the presence of impurities.

The assessment has been conducted at the extraction stage. We consider a  $BaSO_4$  content of 98% in barytes ores and concentrates, based on the hypothesis of the minimum purity for industrial grade for export purpose. Data sources are WMD (2019) for production (in kg of  $BaSO_4$ ) and COMEXT (CN 25111000) for trade.



**Figure 16: End uses and EU sourcing of barytes (Average 2012 to 2016)<sup>8</sup>**

Over the 2012-2016 period, the global production of baryte decreased by about 14%. The leading global supplier is China, with an average share of 38% in the world production,

<sup>7</sup> JRC elaboration from multiple sources, see next sections.

<sup>8</sup> JRC elaboration from multiple sources



followed by India, with 12%. Export restrictions to barytes are applied by China and Vietnam (OECD, 2019).

In the EU, the only mining activities are in Germany (primary) and Bulgaria (reworking tailings). The much cheaper imports from India and China make domestic mining a rather unattractive option. Over the 2012-2016 period, the EU imports of baryte diminished by 27%, while the exports only had small fluctuations. Import reliance for baryte is 70%.

Being baryte used extensively in the oil industry as a weighting agent for drilling muds, its worldwide market developments are strongly related with those of the oil industry, i.e. most likely a diminishing demand on the medium and long term, resulting in excess supply.

The price of baryte ores have a slightly decreasing trend in China, which is reflected also in the US price of the ground baryte, at around 180 US\$ per tonne in 2018.

The EU annual average consumption of baryte is 506,410 tonnes per year, averaged over 2012-2016. Its sourcing is mainly from outside EU: China (38%) and Morocco (28%), but 25% comes from EU member states, out of which Germany is the major provider (10% of the total EU sourcing).

Baryte is mainly used as a weighting agent (about 60% of end uses) or to elevate hydrostatic pressure to counteract high-pressure zones during drilling activities. The high specific gravity of baryte makes it suitable for a wide range of industrial, medical, and manufacturing uses.

Several substitutes are available for these applications, but for the moment they are either economically less attractive (for drilling), or have inferior quality (for fillers) or they are not safe (for medical applications).

Various sources estimate the EU reserves of barytes to be around 13.1 million tonnes (in Ba content), while at the global level these are projected at 380 million tonnes.

According to SCREEN, baryte is present in small deposits in various EU countries (Belgium, Bulgaria, Croatia, Czech Republic, France, Germany, Ireland, Italy, Poland, Portugal, Romania, Spain and Sweden). In Portugal, a proved mineral reserve of 112,000 tonnes for baryte is found in the Serras da Mina Fe-Mn-baryte mine.

## 2.2 Market analysis, trade and prices

### 2.2.1 Global market analysis and outlook

The World Mining Data reveals a clear decreasing trend in the world production of baryte, more precisely a decline by 14% over the 2012-2016 period. The biggest global supplier is China (32%), followed by India (12%), Morocco (10%), Iran (8%), Kazakhstan (7%), Turkey and United States, with 6% of the world production each.

The consumption in "drilling mud" - and therefore of baryte - fluctuates from year to year, as it is correlated with the amount of exploration drilling for oil and gas, which in turn depends, among others, on oil and gas prices.

**Table 7: Qualitative forecast of supply and demand of barytes**

<b>Materials</b>	<b>Criticality of the material in 2020</b>	<b>Demand forecast</b>	<b>Supply forecast</b>
------------------	--	------------------------	------------------------

	Yes	No	5 years	10 years	20 years	5 years	10 years	20 years
Baryte	X		+	+ -	- +	+ -	+ -	?

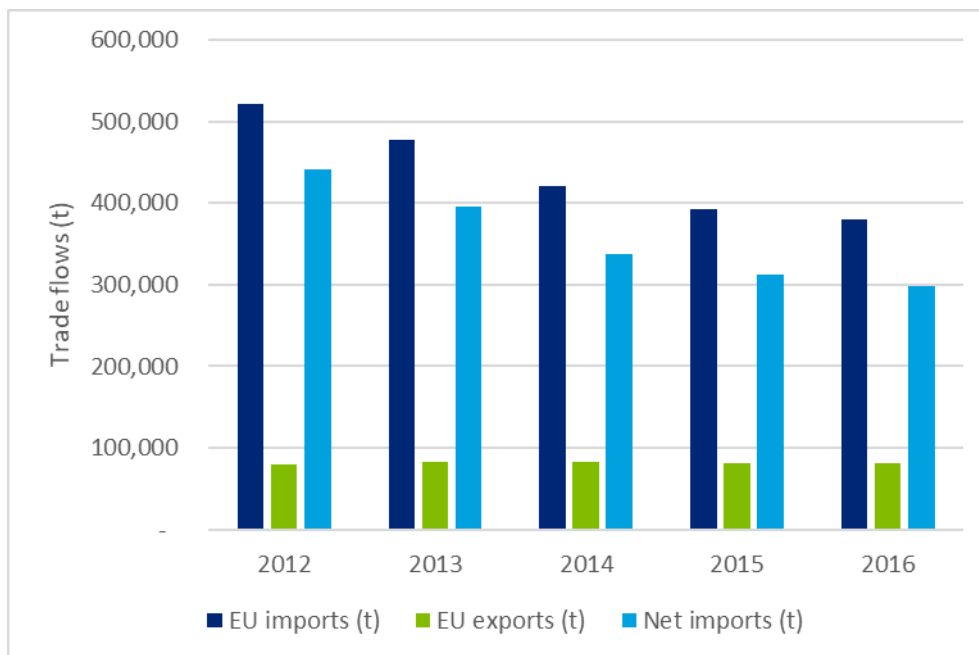
We have found no reliable demand and supply forecasts for the next 5, 10 and 20 years from industry experts or from the literature. Nonetheless, we expect the baryte demand to follow global energy trends. In the medium term, the world demand for oil is likely to keep growing, although the rate of growth is slowing down (IEA, 2019). However, the implementation of climate change policies is likely to impact the demand of oil in the energy mix, substantially diminishing its share. From this perspective, on medium and longer term one could expect rather a moderation of demand for baryte, resulting eventually in excess supply.

For the moment, baryte continues to be the preferred commodity for usage in drilling. Nevertheless, the availability of a large number of substitutes might influence its future market developments.

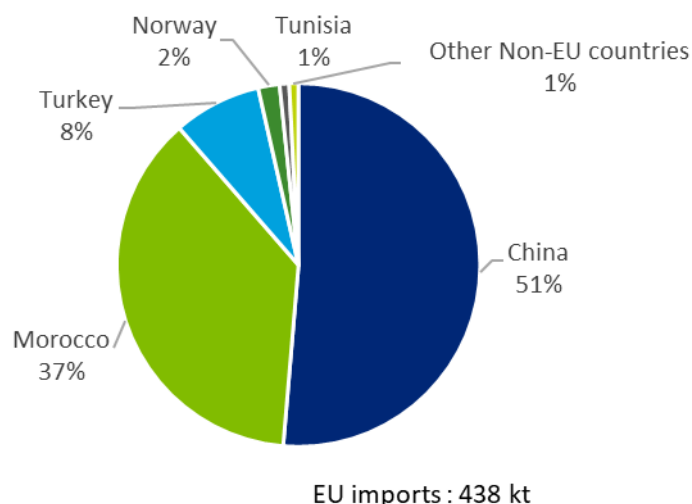
### 2.2.2 EU trade

Over the 2012-2016 period, the EU imports of baryte diminished by 27% (almost 141,000 tonnes per year). Over the same time period, the exports only showed small fluctuations, remaining stable around 80,000 tonnes per year. These developments resulted in a decreasing trend of net imports.

The EU imports of barytes were mainly from China, Morocco, and Turkey. Free Trade Agreements between EU and Morocco, Turkey, Tunisia, Norway are in place.



**Figure 17: EU trade flows for barytes (Averaged over the 2012-2016)(Eurostat, 2019b)**



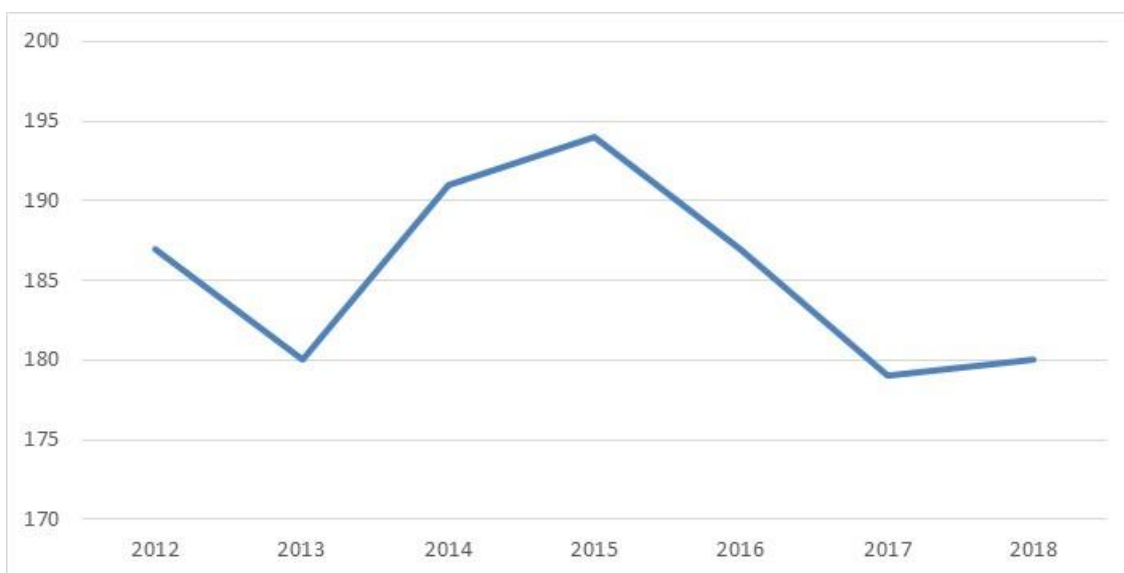
**Figure 18: EU imports of barytes. Average 2012-2016 (Eurostat 2019b)**

### 2.2.3 Prices and price volatility

Prices for Chinese drilling grade barytes have decreased over the past five years, from 131-135 USD per tonne FOB China in 2012 to 80-90 USD per tonne by the end of 2017.

Beyond the extraction stage, the price of baryte depends on the degree of processing, which is determined by use/end-use and its quality requirements. Drilling-grade baryte has typically the lowest price. Filler applications command higher prices due to the required physical processing (by grinding and micronising), and there are further premiums for whiteness and brightness and colour (The Barytes Association, 2016).

As estimated by USGS, for the year 2017 and 2018, the price for ground baryte is about 180 USD/tonne FOB, but over the 2012-2016 period has fluctuated, with an overall slightly decreasing trend (Figure 19).



**Figure 19. Prices of baryte, ground (USD per tonne) from 2012 to 2018 (Data from USGS)**

Due to its main application for drilling, the key driver for the baryte market is the evolution of oil and gas exploration (following trends in the fossil fuel production, influenced by the

rise in global demand for energy, and its composition). Fast-growing economies like China and India are expected to be the main contributors to the increasing global demand of oil and gas, due to the increasing energy consumption accompanying their rapid industrialization and urbanization.

## **2.3 EU demand**

---

### **2.3.1 EU demand and consumption**

Over the period 2012-2016, the EU consumed on average about 506,000 tonnes per year of barium contained in baryte.

Net trade as a percentage of apparent consumption (i.e. the import reliance) for baryte is 70% on average for that period.

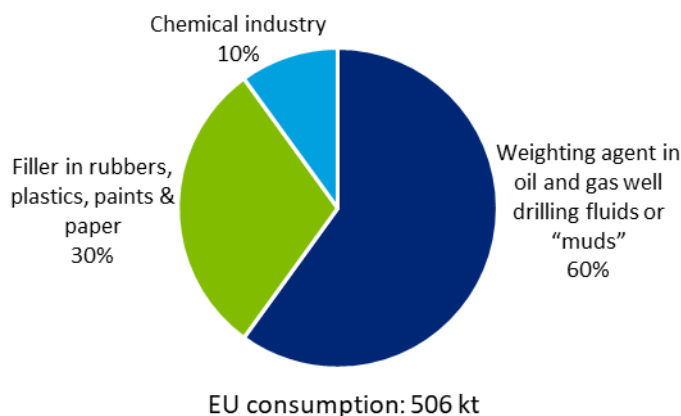
### **2.3.2 Uses and end-uses of barytes in the EU**

Baryte is primarily used as a weighting agent in drilling fluids or “drilling muds” for oil and gas wells, where baryte’s high specific gravity assists in containing pressures and preventing blowouts. Ground baryte is combined with bentonite, water, and other materials to manufacture “mud” which is pumped down the drill hole. Drilling muds remove cuttings up to the surface, while cooling and lubricating the drill bit (Schlumberger, 2013). In drilling muds, the current standard is the API (American Petroleum Institute) specification 13A 4.1 or 4.2. New standards are under discussion.

Baryte is also used as a heavy filler in rubber, paint and plastics applications. The automotive industry mostly uses baryte as a soundproofing material in moulded components, floor mats, and in friction products such as breaks and clutches pads. In the construction sector, baryte is used for the production of building materials or of special types of concrete having x-ray protection and sound insulation. Baryte is used as filler in asphalt, in high quality primers and anti-corrosion coatings, abrasion-resistant paint such as bituminous paints etc. (Mineralia, 2016).

In the chemical industry baryte is used for the preparation of barium compounds, notably barium carbonate ( $BaCO_3$ ). The latter is used in the production of special glass, as an ingredient in high-fire glazes, and in the brick and tile industry (BRGM, 2014).  $BaCO_3$  is increasingly used in electronic components, such as electronics ceramics and capacitors. Another barium compound, barium meal (barium sulphate), is used in radio-diagnosis.

In the EU, the oil and gas production accounted for more than half of the baryte consumption, while the remainder went to the chemicals and filler (The Barytes Association, 2016)(Figure 20).



**Figure 20: EU end uses of baryte. Average figures for 2012-2016 (SCREEN, 2019).**

The relevant industry sectors are described using the NACE sector codes in Table 8.

**Table 8: Baryte applications, 2-digit and associated 4-digit NACE sectors, and value added per sector (Eurostat, 2019b)**

Applications	2-digit NACE sectors	4-digit NACE sectors	Value added of sector (M €)
Weighting agent in oil and gas well drilling fluids	C23 - Manufacture of other non-metallic mineral products	C23.9.9 - Manufacture of other non-metallic mineral products n.e.c.	57,255
Filler in rubbers, plastics, paints	C22 - Manufacture of rubber and plastic products	C22.1.1 - Manufacture of rubber tyres and tubes; retreading and rebuilding of rubber tyres	75,980
		C22.2.1 - Manufacture of plastic plates, sheets, tubes and profiles	
Chemical industry	C20 - Manufacture of chemicals and chemical products	C20.1.3 - Manufacture of other inorganic basic chemicals	105,514

### 2.3.3 Substitution

Substitutes for baryte used as a weighting agent for the oil and gas industry include hematite ( $\text{Fe}_2\text{O}_3$ ), ilmenite ( $\text{FeTiO}_3$ ), calcium carbonate ( $\text{CaCO}_3$ ), but they are economically less attractive than baryte. For this application, baryte has currently a market share over 99%. Hematite has a higher density and can be used to reduce the solids' percentage for rheology control, and ilmenite can be used when drilling activities take place close to a cheap supply source (Schlumberger, 2014; Huxtable, 2016).

For fillers, the main substitutes of baryte are calcium carbonate and clays (kaolin, talc), which are widely used for general purpose fillers where quality or technical considerations are less stringent. In fact, they do not match baryte quality in heaviness, sound proofing and radiation shielding.

There are various acceptable substitutes for barium carbonate in several applications in the chemical sector. Strontium carbonate is sometimes used as a substitute in ceramic glaze. There is no alternative to barium carbonate in dielectrics, and no safe substitute for medical applications.

## **2.4 Supply**

---

### **2.4.1 EU supply chain**

The EU production of baryte over the years 2012-2016 is around 149,000 tonnes per year ( $\text{BaSO}_4$ ) (World Mining Data, 2019). The main EU producer is Germany (41% of total EU production), with an average of 60,500 tonnes per year for the same period.

### **2.4.2 Supply from primary materials**

#### **2.4.2.1 Geology, resources and reserves of baryte**

##### **Geological occurrence:**

Baryte deposits are classified into three major types: stratiform, vein, and residual deposits. Stratiform (or bedded) deposits are the dominant source of industrial baryte. They are formed by the precipitation of baryte at or near the seafloor of sedimentary basins (sedimentary-exhalative or 'SEDEX' deposits). These deposits are often associated with volcanic-hosted massive sulphide mineralization (mainly zinc-lead). Individual beds can range from massive to laminated or fine-grained, and may have a baryte content between 50% and 95% which is often greyish to dark-grey in appearance. In vein deposits, baryte forms by precipitation from hydrothermal fluids or deep-seated brines in faults, fractures and cavities. This type of baryte varies in colour from white to yellowish and is often iron-stained. Residual deposits are formed by the dissolution of the host rock of the stratiform or vein deposits, leaving irregular masses of baryte in a clay matrix (BGS, 2005; NSW Department of Industry, 2009).

##### **Global resources and reserves**

There is no single source of comprehensive evaluations of resources and reserves of baryte in different geographic areas of the EU, or globally). The USGS collects information about the quantity and quality of mineral resources but does not directly measure reserves, and companies or governments do not directly report reserves to the USGS. Individual companies may publish regular mineral resource and reserve reports, but reporting is done using a variety of systems depending on the location of their operation, their corporate identity and stock market requirements. Translations between national reporting codes are possible by applying the CRIRSCO template<sup>9</sup>, which is also consistent with the United Nations Framework Classification (UNFC) system. In any case, reserve and resource data are updated continuously with the evolutions of exploration and mining, which are in turn influenced by market conditions.

The USGS (2019) estimated around 740 million tonnes of (identified) resources and 320 million tonnes of reserves, of which half are located in China and Kazakhstan (Table 9).

---

<sup>9</sup> [www.criirSCO.com](http://www.criirSCO.com)

**Table 9: Global reserves of baryte in 2015 (Data from USGS, 2019)**

Country	Estimated Baryte Reserves (tonnes)	Percentage of total (%)
China	36,000,000	11
Kazakhstan	85,000,000	27
Turkey	35,000,000	11
India	51,000,000	16
Iran	24,000,000	8
USA	NA	NA
Morocco	NA	NA
Mexico	NA	NA
Pakistan	30,000,000	9
Other countries	29,000,000	9
<b>World Total (rounded)</b>	<b>320,000,000</b>	<b>100</b>

**EU resources and reserves**

For Europe, there is no complete and harmonised dataset that presents total EU resource and reserve estimates for baryte. Many documented resources in Europe are based on historic estimates.

**Table 10: Resource data for the EU compiled in the European Minerals Yearbook (Minerals4EU, 2019)**

Country	Reporting code	Quantity	Unit	Code Type	Resource
Czech Republic	National reporting code	0.57	Mt	Potentially economic	
France	None	8.8 (BaSO <sub>4</sub> )	Mt	Historic Estimate	Resource
Hungary	Russian Classification	86	Mm <sup>3</sup>	C2	
Ireland	None	1.65	Mt	Historic Estimate	Resource
Italy	None	3.5	Mt	Historic Estimate	Resource
Poland	National reporting code	5.66	Mt	A+B+C1+C2	
Serbia	JORC	1	Mt	Total	
Slovakia	None	3.45	Mt	Verified (Z1)	
Spain	None	9.99	Mt	Historic Estimate	Resource
United Kingdom	None	22	Mt	Total	

USGS (Mineral Commodity Summary, various editions) does not provide data on reserves in EU countries since 2014. Before 2014, reserves data were provided for Germany, the UK, France and Bulgaria (13.1 Mt of baryte for these four countries in 2005 – not expected to have evolved since). The Mineral Profile – Barytes from BGS (2005) provides the same data as USGS.

Resource and reserve data for some countries in Europe are available in the Minerals4EU (2019) website, but they cannot be summed up as they are partial and do not use the same reporting code (Table 10 and Table 11).

According to SCRREEN, baryte is present in small deposits in various EU countries (Belgium, Bulgaria, Croatia, Czech Republic, France, Germany, Ireland, Italy, Poland, Portugal, Romania, Spain, Sweden). In Portugal, a proved mineral reserve of 112,000 tonnes for baryte is present in the Serras da Mina Fe-Mn-baryte mine. In the other EU countries mentioned, no data on reserves is available: in these cases, reserves are considered null (SCRREEN, 2019).

Apart from the German (primary) and the Bulgarian (reworking tailings reworking) mines, no other mine is operating in the EU due to the competition with much cheaper imports from India and China.

**Table 11: Reserve data for the EU compiled in the European Minerals Yearbook (Minerals4EU, 2019)**

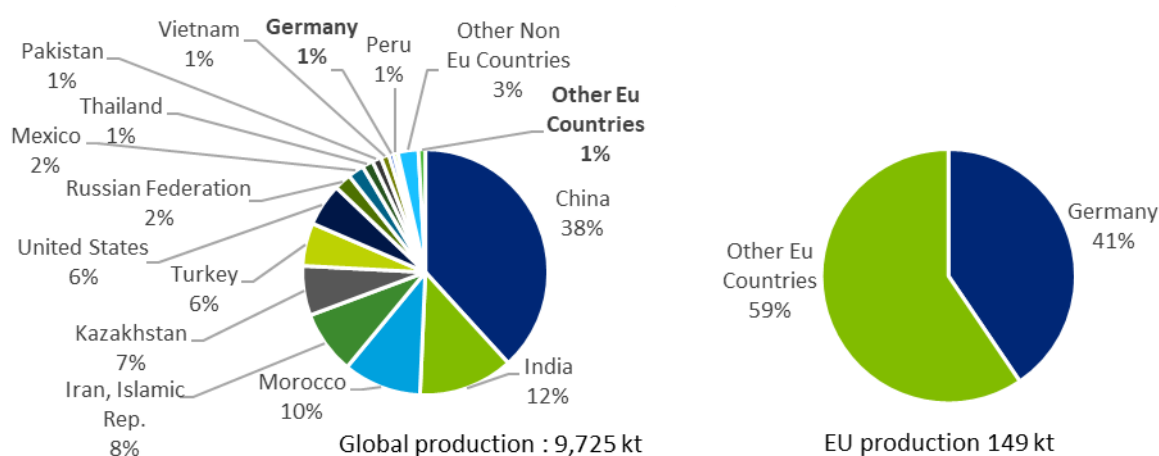
Country	Reporting code	Quantity	Unit	Code Reserve Type
Croatia	National reporting code	185.9	kt	No code
Slovakia	None	633	kt	Verified (Z1)
Spain	N/A	Reserves known to exist		N/A

#### 2.4.2.2 World and EU mine production

World production of baryte is broadly linked to oil-well drilling activity and has increased from around 6 to 6.5 million tonnes per year in the early 2000s to 9.1 million tonnes per year in 2016. China is the largest baryte producer, contributing with an average of 3.7 million tonnes per year over the period 2012-2016 (see Figure 21).

Nevertheless, China's averaged share in the world production of barytes has decreased from 44% to 38% as compared to the average in 2010-2014 (CRM 2017). The second biggest supplier of baryte is India, which has also diminished its share in world production, from 18% to 12%. In return, several countries have increased their share in global baryte production over the period 2012-2016: Iran (from 4% to 8%), Kazakhstan (from 5% to 7%), Turkey (from 3% to 6%), and Russian Federation (from <1% to 2%).

The EU accounts for almost 2% of the world production of barytes averaged over the 2012-2016 period. Within the EU27, besides Germany, baryte is mined in Bulgaria and Slovakia. Since 2016, Bulgaria became the major producer and in 2017 accounted for 56% of EU27 production of baryte.



**Figure 21: Global and EU mine production of baryte, average 2012–2016 (WMD, 2019)**



The EU sourcing relies mainly on two extra-EU countries - China (38%) and Morocco (28%). Nevertheless, one quarter of the EU sourcing comes from domestic supply, out of which Germany is the major provider (10% of the total EU sourcing) (Figure 21).

### 2.4.3 Supply from secondary materials/recycling

Baryte is barely re-used. As baryte only constitutes a small percentage of the total cost of any drilling project, only a very small quantity is recycled for re-use beyond the amount recovered at drill sites (U.S. Department of the Interior & USGS, 2014). In most other applications, baryte is not recovered at all (as in fillers, etc.) and cannot be recycled. An exception is the use of baryte in glass during glass recycling.

In the current assessment, the end-of-life recycling input rate for baryte is considered 1%, as in the previous assessment and confirmed by SCRREEN experts (2019).

### 2.4.4 Processing of baryte

After natural barytes are extracted they are usually sorted through physical separation from other compounds (e.g. gravity separation or flotation methods) and crushed, on or near the mining site, to get ground barytes, micronized barytes, baryte aggregates, etc. In a few cases, additional processing may be conducted to obtain the quality and colour required by the specific applications.

## 2.5 Other considerations

### 2.5.1 Environmental, health and safety issues

The naturally occurring mineral baryte is not subject to EU REACH regulations (ECHA, 2017). However, the re-precipitated blanc-fixe (barium sulphate) and also the barium salts are subject to REACH.

The barium content of drinking water, food, and soils is rarely high enough to present a human health concern and no adverse toxicological effects of barium on plants or wildlife have been reported near baryte mines or elsewhere (USGS, 2017)<sup>10</sup>.

### 2.5.2 Socio-economic issues

We find no specific information about socio-economic issues related to barytes. Nevertheless, we suspect that for the major world producers - China and India - economic implications of baryte production might be relevant, especially in terms of jobs at the local and regional levels.

## 2.6 Comparison with previous EU assessments

The assessment has been conducted at the extraction stage, using the same methodology as for the 2017 list.

The results of this and of earlier assessments are shown in Table 12.

**Table 12: Economic importance and supply risk for baryte in the assessments of 2011, 2014, 2017, 2020 (European Commission, 2011-2014-2017)..**

	2011		2014		2017		2020	
Indicator	EI	SR	EI	SR	EI	SR	EI	SR

<sup>10</sup> <https://pubs.usgs.gov/pp/1802/d/pp1802d.pdf>

Baryte	3.7	1.7	2.8	1.7	2.9	1.6	3.3	1.26
--------	-----	-----	-----	-----	-----	-----	-----	------

Compared to the previous assessment, the economic importance has increased, while the supply risk is lower.

## 2.7 Data sources

### 2.7.1 Data sources used in the factsheet

BGS (2005). Mineral profiles: Barytes. [online] Available at: <http://www.bgs.ac.uk/mineralsUK/statistics/mineralProfiles.html>

BGS (2019). World Mineral Production 2012-2016. [online] British Geological Survey, Available at: <http://www.bgs.ac.uk/mineralsuk/statistics/home.html>

BRGM (2014). Mémento Barytine. Rapport BRGM/RP-63974-FR. <http://infoterre.brgm.fr/rapports/RP-63974-FR.pdf>

Duntanlich Mine (2014). Duntanlich Background. [online] Available at: <http://duntanlich.com/>

ECHA (2019). Registered substances. [online] available at: <https://echa.europa.eu/>

European Commission (2011). Critical raw materials for the EU. [online] Available at: [https://ec.europa.eu/growth/sectors/raw-materials/specific-interest/critical\\_en](https://ec.europa.eu/growth/sectors/raw-materials/specific-interest/critical_en)

European Commission (2014). Report on Critical Raw Materials for the EU. Non-Critical Raw Materials Profiles [online] Brussels European Commission, Available at: <http://ec.europa.eu/growth/sectors/raw-materials/specific-interest/critical/>

European Commission (2019). Free trade agreements. [online] Available at: <http://ec.europa.eu/trade/policy/countries-and-regions/agreements/>

Eurostat (2019)a. International Trade Easy Comext Database [online] Available at: <http://epp.eurostat.ec.europa.eu/newxtweb/>

Eurostat (2019)b. Annual detailed enterprise statistics for industry (NACE Rev. 2, B-E). [online] Available at: [http://ec.europa.eu/eurostat/en/web/products-datasets/-/SBS\\_NA\\_IND\\_R2](http://ec.europa.eu/eurostat/en/web/products-datasets/-/SBS_NA_IND_R2)

Huxtable (2016 & 2017). The Barytes Association. Personal communication, 2016 & 2017.

IEA (2019), Oil 2019 Analysis and forecasts to 2024, available at: <https://www.iea.org/oil2019/>

Mineralia (2016). Applications. [online] Available at: <http://mineralia.es/en/sectors/construction.html>

Minerals4EU (2019). European Minerals Yearbook. [online] Available at: [http://minerals4eu.brgm-rec.fr/m4eu-yearbook/theme\\_selection.html](http://minerals4eu.brgm-rec.fr/m4eu-yearbook/theme_selection.html)

OECD (2019). OECD Export restrictions on Industrial Raw Materials. [online] Available at: [http://qdd.oecd.org/subject.aspx?Subject=ExportRestrictions\\_IndustrialRawMaterials](http://qdd.oecd.org/subject.aspx?Subject=ExportRestrictions_IndustrialRawMaterials)

Schlumberger (2014). Technical Paper: Alternative Drilling Fluid Weighting Agents: A Comprehensive Study on Ilmenite and Hematite. [online] Available at: [http://www.slb.com/resources/technical\\_papers/miswaco/167937.aspx](http://www.slb.com/resources/technical_papers/miswaco/167937.aspx)

The Barytes Association [(2016 & 2017 (P. Huxtable, personal communication)]. [online] Available at: <http://www.barytes.org/>

U.S. Department of the Interior & USGS (2014) —A Case Study of Import Reliance on an Essential Material for Oil and Gas Exploration and Development Drilling, Scientific Investigations Report 2014–5230

USGS (2019). Mineral Commodity Summaries. Barite. [online] Available at: <https://www.usgs.gov/centers/nmic/mineral-commodity-summaries>

SCREEN workshop. (2019). Validation Workshop on Critical Raw Materials, 10-12 September 2019, Thon Hotel Brussels City Centre.

WMD (2019) World Mining Data 2019, Reichl, C.; Schatz, M; Zsak, G. Iron and Ferro Alloy Metals, non Ferrous Metals, Precious Metals, Industrial Minerals, Mineral Fuels. Austrian Federal Ministry of Sustainability and Tourism. [online] Available at: [www.en.bmwfw.gv.at/Energy/WorldMiningData/Seiten/default.aspx](http://www.en.bmwfw.gv.at/Energy/WorldMiningData/Seiten/default.aspx)

### **2.7.2 Data sources used in the criticality assessment**

Baker, H. (2006). Drilling Fluids Reference Manual. [online] Available at: [http://www.fanarco.net/books/drilling/Drilling\\_Fluids\\_Reference\\_Manual.pdf](http://www.fanarco.net/books/drilling/Drilling_Fluids_Reference_Manual.pdf)

Barytine et Minéraux (2016). Eric Tardif, director, Personal communication, Now ETHIC SAS, 36310 Chaillac, France.

BGS (2019). World Mineral Production 2012-2016. [online] British Geological Survey, Available at: <http://www.bgs.ac.uk/mineralsuk/statistics/home.html>

BRGM (2014). Mémento Barytine. Rapport BRGM/RP-63974-FR. [online] Available at: <http://infoterre.brgm.fr/rapports/RP-63974-FR.pdf>

Ciullo, Peter A., (1996). Barite, pp 21-23, in Ciullo P.A.(Ed), Industrial minerals and their uses: a handbook and formulary. Noyes Publications, USA. [online] Available at: <http://rushim.ru/books/geochemie/industrial-minerals-and-their-uses.pdf>

European Commission (2014). Report on Critical Raw Materials for the EU. Non-Critical Raw Materials Profiles [online] Brussels European Commission, Available at: <http://ec.europa.eu/growth/sectors/raw-materials/specific-interest/critical/>

European Commission (2016). Free trade agreements. [online] Available at: <http://ec.europa.eu/trade/policy/countries-and-regions/agreements/>

Eurostat (2016)a. International Trade Easy Comext Database [online] Available at: <http://epp.eurostat.ec.europa.eu/newxtweb/>

Eurostat (2016)b. Annual detailed enterprise statistics for industry (NACE Rev. 2, B-E). [online] Available at: [http://ec.europa.eu/eurostat/en/web/products-datasets/-/SBS\\_NA\\_IND\\_R2](http://ec.europa.eu/eurostat/en/web/products-datasets/-/SBS_NA_IND_R2)

INFORMED oil and gas conference (2015). Data reported by Peter Huxtable from The Barytes Association.

OECD (2016). OECD Export restrictions on Industrial Raw Materials. [online] Available at: [http://qdd.oecd.org/subject.aspx?Subject=ExportRestrictions\\_IndustrialRawMaterials](http://qdd.oecd.org/subject.aspx?Subject=ExportRestrictions_IndustrialRawMaterials)

Schlumberger Limited (2014). Technical Paper: Alternative Drilling Fluid Weighting Agents: A Comprehensive Study on Ilmenite and Hematite. [online] Available at: [http://www.slb.com/resources/technical\\_papers/miswaco/167937.aspx](http://www.slb.com/resources/technical_papers/miswaco/167937.aspx)

Scogings, A (2014). Drilling grade barite: the global outlook. [online] Available at: <http://www.csaglobal.com/wp-content/uploads/2015/03/Drilling-grade-barite-the-global-outlook-IM-Mag-January-2015.pdf>

The Barytes Association (2016). [online] Available at: <http://www.barytes.org/>

Vanderbilt Minerals (2013). Filler Minerals Reference - A Guide to Filler Properties and Uses, Report N°703; [http://www.vanderbiltminerals.com/ee\\_content/Documents/Technical/VR\\_703\\_Paint\\_Filler\\_Minerals\\_Reference\\_Web.pdf](http://www.vanderbiltminerals.com/ee_content/Documents/Technical/VR_703_Paint_Filler_Minerals_Reference_Web.pdf)

U.S. Department of the Interior & USGS (2014) —A Case Study of Import Reliance on an Essential Material for Oil and Gas Exploration and Development Drilling, Scientific Investigations Report 2014–5230.

USGS (2019). Mineral Commodity Summaries. Available at: <https://www.usgs.gov/centers/nmic/mineral-commodity-summaries>

SCREEN workshop. (2019). Validation Workshop on Critical Raw Materials, 10-12 September 2019, Thon Hotel Brussels City Centre.

WMD (2019) World Mining Data 2019, Reichl, C.; Schatz, M; Zsak, G. Iron and Ferro Alloy Metals, non Ferrous Metals, Precious Metals, Industrial Minerals, Mineral Fuels. Austrian Federal Ministry of Sustainability and Tourism. [online] Available at: [www.en.bmwf.gv.at/Energy/WorldMiningData/Seiten/default.aspx](http://www.en.bmwf.gv.at/Energy/WorldMiningData/Seiten/default.aspx)

## **2.8 Acknowledgments**

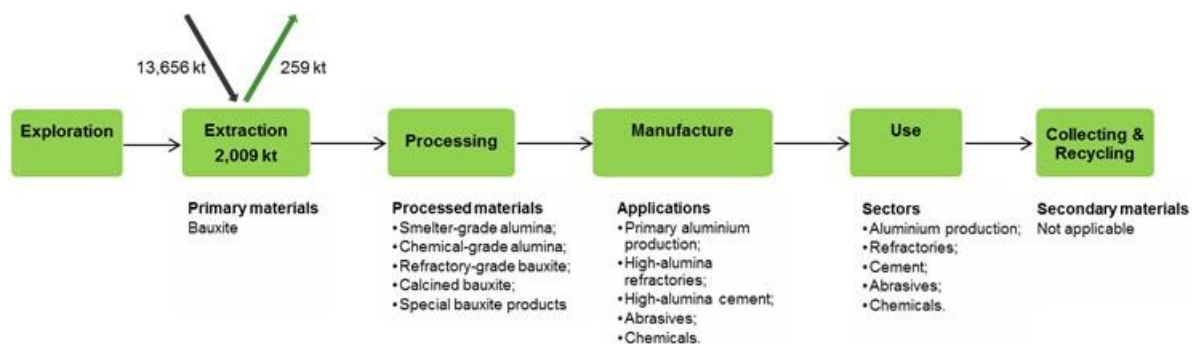
---

This factsheet was prepared by the JRC. The authors would like to thank Mrs. Corina Hebestreit (Euromines), the EC Ad Hoc Working Group on Critical Raw Materials (especially to Mr. Lluís Fontboté) and all other relevant stakeholders for their contributions to the preparation of this factsheet.

# 3 ALUMINIUM AND BAUXITE

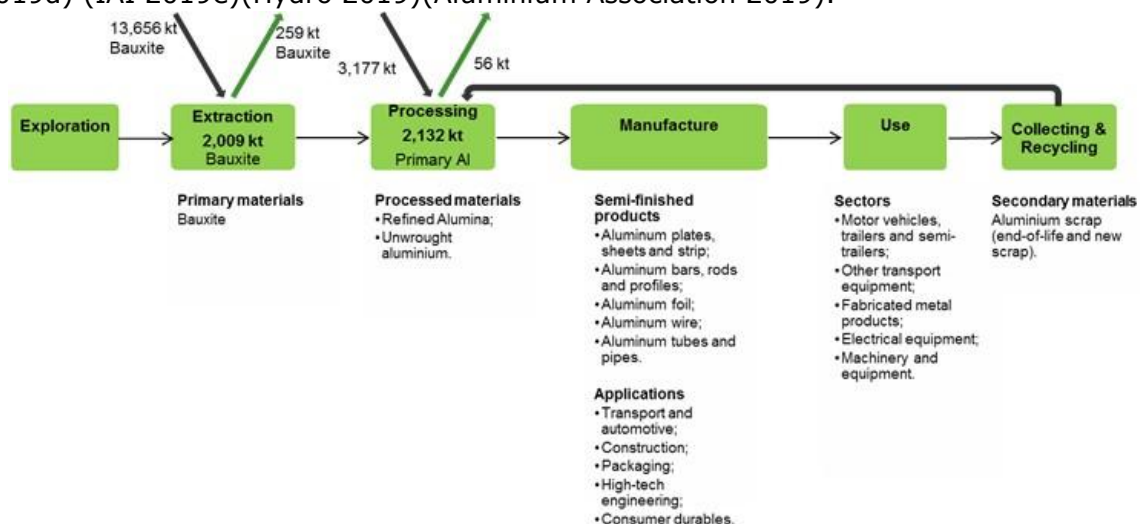
## 3.1 Overview

Bauxite is the primary raw material used to produce aluminium metal. It is a heterogeneous ore composed primarily of aluminium-containing minerals (gibbsite, boehmite and diaspor) with varying quantities of silica, iron oxides and other associated minerals. Bauxite generally contains more than 40% of aluminium oxide. Bauxite is refined into an intermediate product, alumina, which is then smelted into aluminium.



**Figure 22: Simplified value chain for bauxite for the EU, averaged over 2012-2016<sup>11</sup>**

Aluminium (chemical symbol Al) is a lightweight, silver-grey metal, and a good conductor of heat and electricity. Aluminium’s superior malleability and low melting point of 660°C makes it highly workable and versatile. Also, the ability to form numerous alloys enhances its versatility. Furthermore, aluminium is highly corrosion-resistant as it develops a natural oxide layer, protecting it against corrosion. Another key property is that aluminium has a remarkable strength to weight ratio; some heat-treatable alloys offer similar performance to advanced steels and titanium. As a final point, aluminium is fully recyclable and reusable an infinite number of times. The combination of its excellent properties has made aluminium the second most widely used metal in modern society (European Aluminium 2019d) (IAI 2019e)(Hydro 2019)(Aluminium Association 2019).



**Figure 23: Simplified value chain for aluminium for the EU, averaged over 2012-2016**

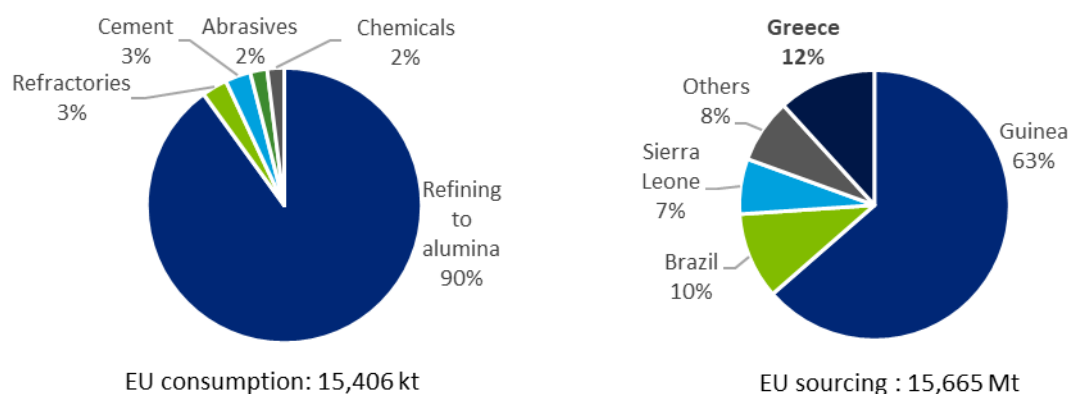
<sup>11</sup> JRC elaboration on multiple sources (see next sections)

Bauxite and aluminium are assessed separately in order to address bauxite’s importance in the aluminium supply chain. But also the non-metallurgical applications of bauxite and bauxite-sourced materials to the downstream manufacturing industry. Bauxite is analysed at the extraction stage, i.e. bauxite ore, and aluminium at the processing stage, in the form of primary aluminium. No assessment has been made for the criticality of the intermediate stage between bauxite and primary aluminium, namely the production of alumina. However, information for alumina refining is provided in the factsheet.

The trade codes used in this assessment are: CN 26060000 “Aluminium ores and concentrates”, for bauxite; CN 76011000 “Aluminium, not alloyed, unwrought” and CN 76012010 “Unwrought primary aluminium alloys”, for primary aluminium (Eurostat Comext 2019).

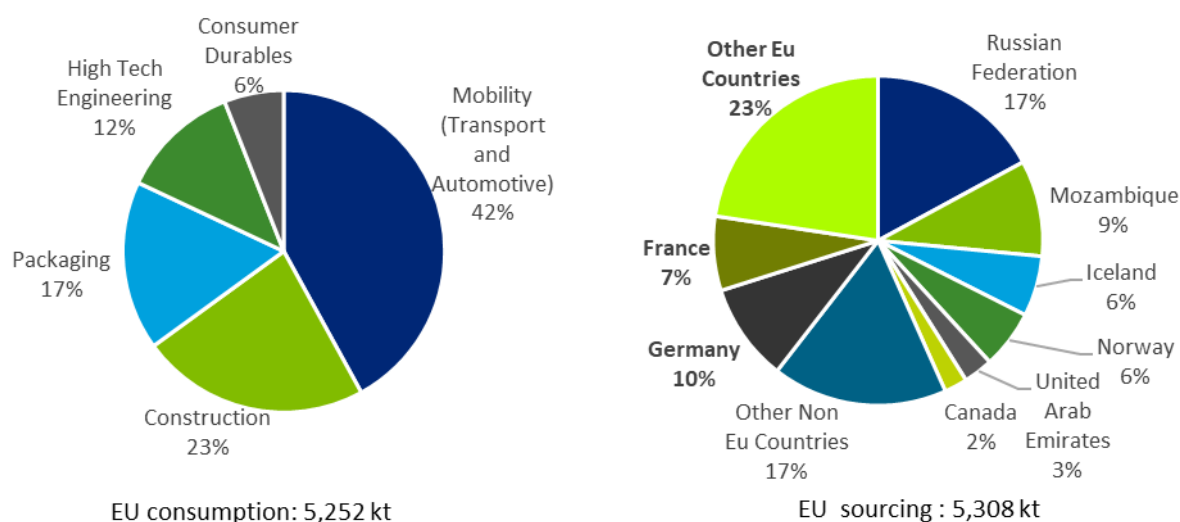
In 2016, the value of the world production of bauxite is estimated at EUR 12.7 billion, and of primary aluminium at EUR 86 billion. The leading importers are China for bauxite and the US for unwrought aluminium. The most significant exporting countries for bauxite are Australia, Malaysia and Guinea, while for unwrought aluminium are Canada, Russia and the United Arab Emirates. Demand for primary aluminium is forecasted to remain strong in Europe and worldwide by 2050, increasing by 50% up to 2050 globally compared to 2017 demand. The growth of the European demand for semi-finished aluminium is expected to rise strongly by a rate of 39% from 2017 to 2050, driven by transport (55% of growth), construction (28% of growth), and packaging (25% of growth).

World market prices for primary aluminium dropped significantly by 39% over the 2007-2016 period. In 2018, the average annual price of aluminium rose to USD 2,108/t, i.e. a price increase of 31% since 2016. Nevertheless, in real terms the price declined by about 24% since 2007.



**Figure 24: End uses (International Aluminium Association and literature; SCREEN workshops 2019) and EU sourcing of bauxite (average 2012-2016) (WMD 2019; Eurostat Comext 2019).**

The EU consumption of bauxite was 15,406 kt per year averaged over 2012-2016, which are mostly sourced through imports, mainly from Guinea (63%) and Brazil (10%). Greece is the leading domestic producer, contributing to EU sourcing by 12%. The import reliance of the EU was 87% between 2012 and 2016.



**Figure 25: End uses (European Aluminium 2018a) and EU sourcing of aluminium (average 2012-2016) (WMD 2019; Eurostat Comext 2019).**

Averaged over 2012 to 2016, the consumption of primary aluminium in the EU was 5,252 kt, which are sourced through domestic production, mainly in Germany (10%) and France (7%), and through imports, mostly from Russia (17%) and Mozambique (9%). The Import reliance of the EU was 59% (average 2012-2016) (Euro Comext 2019). Approximately 90% of bauxite mined in the world is converted to alumina (aluminium oxide) using the Bayer process. Around 80–90% of the world’s alumina is smelted to aluminium using the Hall-Heroult process. The typical bauxite grade useable in the Bayer process consists of 50-55% Al<sub>2</sub>O<sub>3</sub>, up to 30% of Fe<sub>2</sub>O<sub>3</sub>, and up to 1.5% of SiO<sub>2</sub>. Bauxite is also used in refractories, cement, abrasives, chemicals and other minor uses. Practically, aluminium extraction of other ores or minerals than bauxite is not commercially available.

Aluminium products are used in many domains, including transportation (aircrafts, vehicles, trains, boats, etc.), buildings and construction (windows, doors, cladding, curtain walls, etc.), packaging (beverage cans, foil, food trays, boxes, etc.), high-tech engineering (electrical transmission lines, ladders, cylinder blocks, pistons, pulleys, etc.) and consumer products (domestic appliances, cooking utensils, cutlery, coins, etc.). A wide range of substitutes exists for aluminium, e.g. composite materials, magnesium, titanium and steel in mobility applications, steel and wood in construction, glass and plastic for packaging applications, copper for electrical applications.

The aluminium industry and aluminium are at the core of the implementation of the European Commission’s long-term strategy for a modern, competitive, prosperous and climate-neutral economy by 2050<sup>12</sup>. As an energy-intensive industry, aluminium production covers the largest part of the greenhouse gas emissions of the EU non-ferrous metals sector, despite the considerable decrease of emissions achieved during the last years. The European aluminium sector accounted in 2016 for around 1% of the verified emissions of all stationary installations of the European Union and about 2% of its industrial emissions (European Commission 2018).

Further emissions reduction in the aluminium industry is achievable through new low-carbon technologies for primary production, the shift to secondary production through additional recycling, and by a decarbonised power sector. Finally, aluminium’s unique properties make it a key enabler for the low-carbon and circular economy in areas such as the light-weighting in mobility, energy efficiency in construction, wind power, etc.

<sup>12</sup> [https://ec.europa.eu/clima/policies/strategies/2050\\_en](https://ec.europa.eu/clima/policies/strategies/2050_en)

(European Political Strategy Centre 2018) (European Aluminium 2019c)(European Aluminium 2019e).

Estimates of world bauxite reserves are 30,000 million t, which are mainly located in tropical and subtropical regions. Guinea (25%) and Australia (20%) have the world's largest bauxite reserves. In the EU, Greece holds the largest exploitable bauxite deposits (250 million t) (USGS 2018b). Bauxite resources are also located in France, Hungary and Romania (Minerals4EU 2019).

The world production of bauxite is about 280 million t annually (average 2012-2016), with 29% mined in Australia and 20% in China. The EU mine production of bauxite is around 2 million t per year, with 92% produced in Greece. Global alumina annual average production amounts to nearly 109 million t in Al<sub>2</sub>O<sub>3</sub> content, and China represented 47% of the worldwide output. Australia (19%) and Brazil (9%) are other prominent market players in the world supply of alumina. The EU alumina production is 5.8 million t per year, with Ireland (30%) and Spain (25%) producing more than half (BGS 2019).

The global primary aluminium production between 2012 and 2016 amounted to 54,628 kt per year. China is the world's largest producer of primary aluminium, making up over half of the worldwide output (52%). Russia (7%) and Canada (5%) are the second and third world producer respectively. The EU production of primary aluminium is nearly 2,131 kt per year, averaged over 2012 to 2016. Germany (24%) and France (19%) are the leading EU producers. Recycling represents a significant aspect of global aluminium supply, as more than one-third of aluminium metal that is produced globally originates from old or new scrap. In the EU, the ratio of recycling from old scrap to European demand for aluminium (end-of-life recycling input rate) results in 12% in 2013 (Passarini et al. 2018).

The massive expansion during the last decade of Chinese capacity in all stages of the aluminium value chain driven by government intervention has distorted the global aluminium market substantially. Guinea, which is the main source for the EU supply of bauxite, has very weak governance which makes up a considerable risk to the responsible sourcing of bauxite and aluminium.

## **3.2 Market analysis, trade and prices**

---

### **3.2.1 Global market**

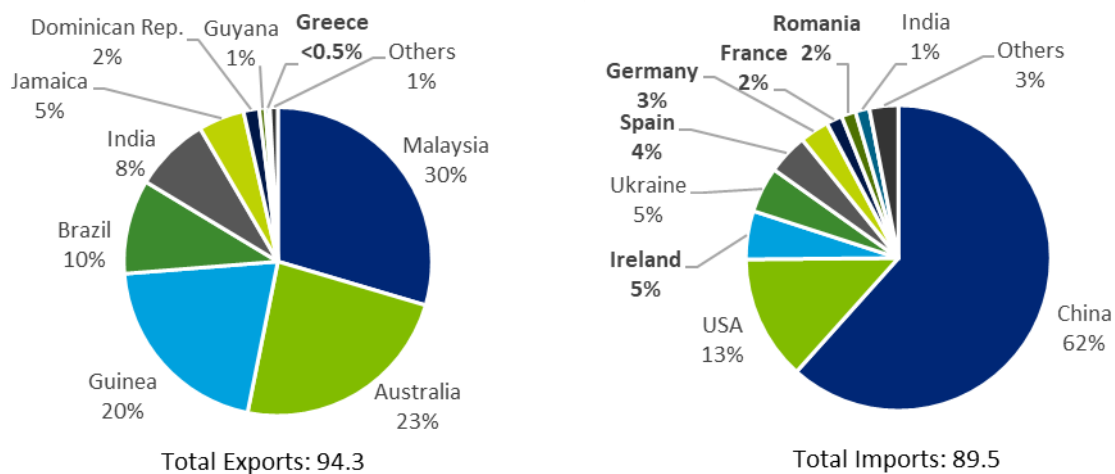
The geographic distribution of the aluminium industry producing centres has shifted significantly during the last 20 years to regions endowed with abundant bauxite or energy resources. New countries have emerged as significant bauxite producers (e.g. China, Brazil and Indonesia), while production in the global alumina industry has been relocated from the industrialised countries towards countries with access to plentiful and inexpensive bauxite sources.

The world production of bauxite in 2016 was about 287,951 kt (WMD 2019), worth approximately EUR 12.7 billion<sup>13</sup>. In 2015, the main exporting countries were Malaysia (30%), Australia (23%), and Guinea (20%). Guinea is the fastest-growing exporter of bauxite. China accounted for 62% of world imports by weight (see Figure 26).

---

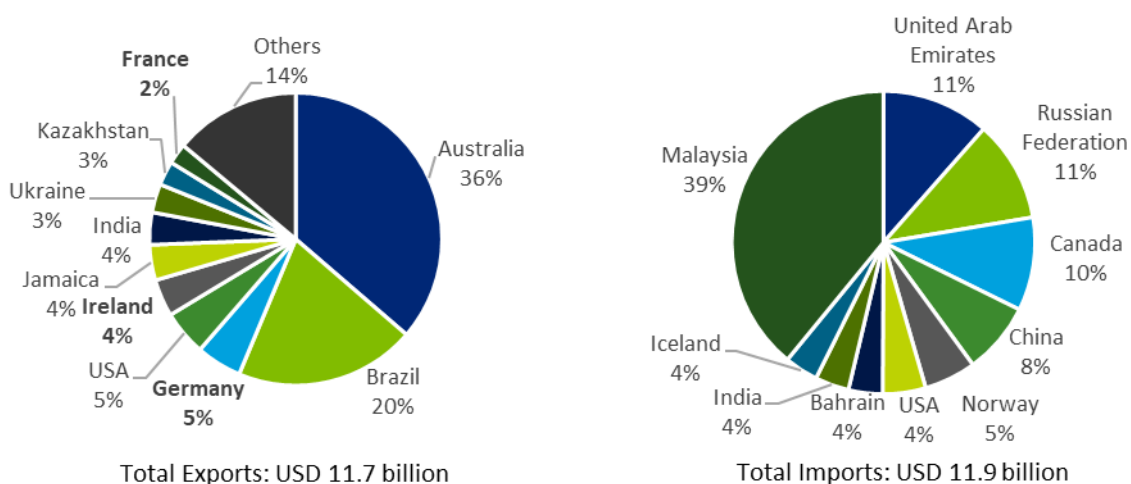
<sup>13</sup> Estimation based on average price of bauxite in 2016 (EUR 44 per tonne) and the world bauxite production in 2016 of 287,951 kt





**Figure 26: Top-10 bauxite exporting (left) and importing (right) countries in 2015 by weight. Data from (UN Comtrade 2019)**

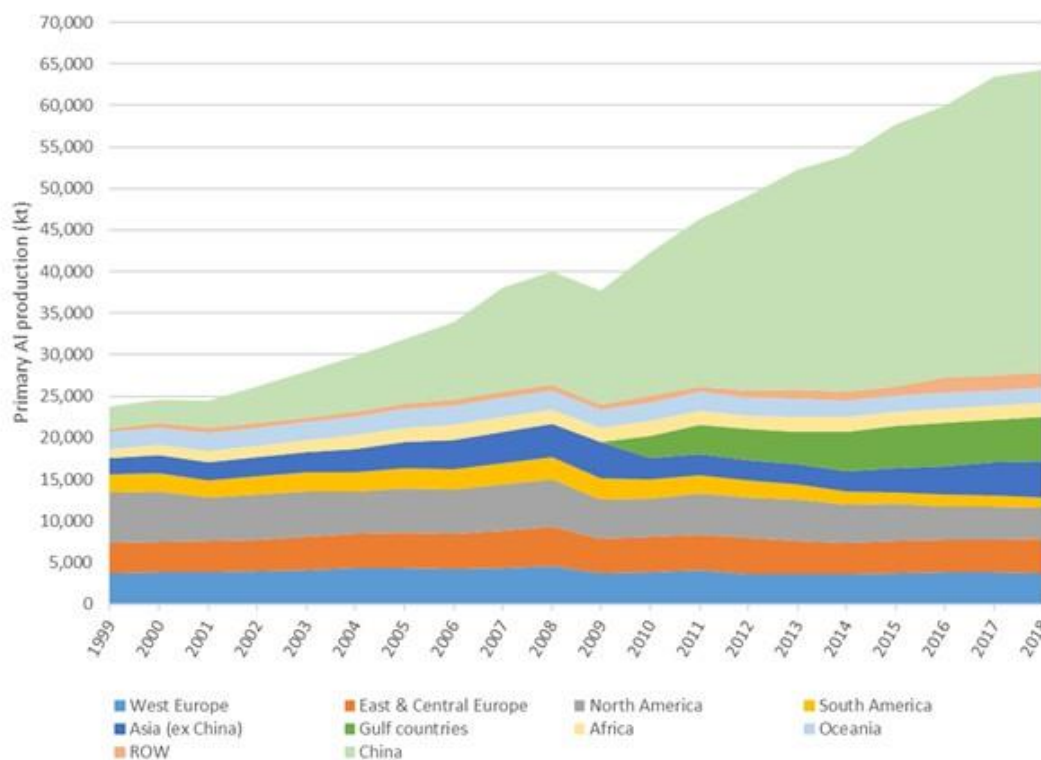
The world production of alumina in 2016 was approximately 118,000 kt (BGS 2019). China has become the largest alumina producer, but continues to import a large share of its bauxite needs (see Figure 26). As shown in Figure 27, in 2016 the main exporting countries were Australia (36%) and Brazil (20%), whereas the major importers were the United Arab Emirates (11%), Russia (11%) and Canada (10%).



**Figure 27: Top-10 alumina exporting (left) and importing (right) countries in 2016 by value (UN Comtrade 2019)**

In the case of primary aluminium production, the shift in the geographic distribution is determined to a large extent by variations in energy prices. Primary output moved from long-established producers in the US, Japan and Europe (except Norway and Iceland) to emerging ones, mostly in China, but also the Middle East and Russia. These emerging producers benefited from combinations of access to abundant and cheap electric power, favourable government policies and programs, and expanding domestic and foreign markets (USITC 2017). Most of the rapidly growing global smelting capacity was installed in China (90% of all new capacity during the last decade), as it is reflected in Figure 28. The continuous increase of aluminium-smelting capacity has led to a decline in world prices of both primary aluminium and downstream exported aluminium products (EC 2018a). In 2018, China accounted for 57% of the world's supply of primary aluminium, up from 11% in 1999 (IAI 2019d). The overwhelming expansion of China's primary production has also

driven the massive build-up of China’s refining capacity for alumina (Aluminum Association et al. 2018).



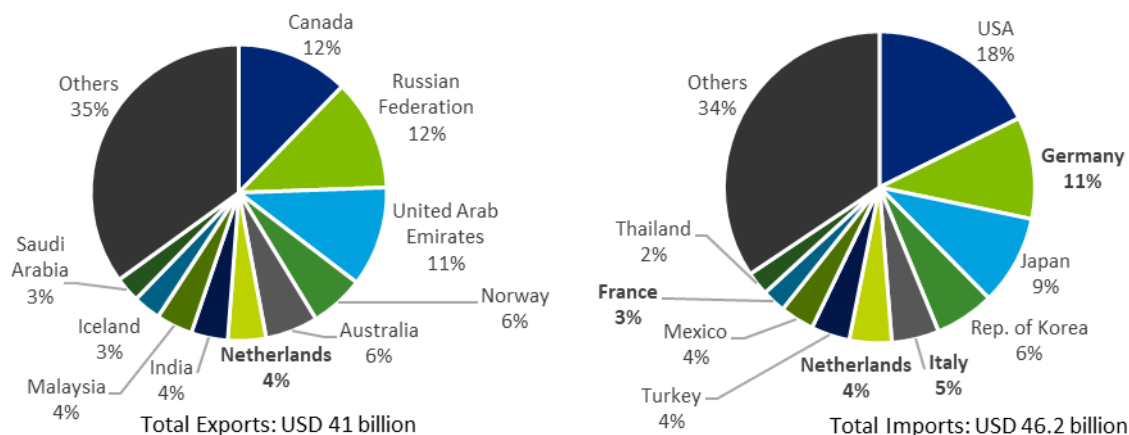
**Figure 28. Growth of primary aluminium production by global region, 1999-2018 (in thousand t) (IAI 2019d)**

A recent report by the Organisation for Economic Cooperation and Development (USGS, 2019b), has highlighted government interventions to the aluminium industry and the related market distortions in the global aluminium value chain. The report concludes that non-market forces appear to explain some of the increases in capacity in the aluminium sector and that the associated market distortions are a genuine concern for the aluminium industry. According to the findings of the study, government support is common throughout the aluminium value chain as all companies examined in the study received support in financial or non-financial form. Government intervention is relatively large in aluminium smelting and exceptionally large in China and countries of the Gulf Cooperation Council. The report asserts that of the documented subsidies provided to the 17 international companies examined, 85% has gone to five Chinese companies. Massive government support to the rapidly growing aluminium smelting industry in China is mostly in the form of energy subsidies and concessional finance.

Another key finding of the study is that apart from direct state support upstream in the value chain, trade measures such as China’s export taxes on primary aluminium and incomplete value-added tax (VAT) rebates on exports of certain aluminium products has benefited downstream producers of semi-finished and fabricated articles of aluminium. Export restrictions discourage exports of primary aluminium, therefore making aluminium cheaper to producers of semis in China than it would otherwise have been and facilitating their exports due to a cost advantage over global competition.

The world production of primary aluminium in 2016 was about 58,649 kt (WMD 2019) worth approximately EUR 86 billion<sup>14</sup>. The US (18%) was the largest recipient of unwrought aluminium, followed by Germany (11%) and Japan (9%). As regards exports, Canada (12%), Russia (12%), and the United Arab Emirates (11%) were the leading world suppliers of unwrought aluminium in 2016 (

Figure 29).



**Figure 29: Top-10 unwrought aluminium exporting (left) and importing (right) countries in 2016 by value (UN Comtrade 2019)**

Another distinctive feature of the global aluminium industry that has changed during the last decades is the degree of concentration and integration at the company level. Currently many producers are not fully integrated with upstream and downstream stages in the value chain as they used to be with vertically integrated companies having assets from bauxite mining to aluminium smelting and further downstream (Nappi 2013).

As regards the exports restrictions imposed by the top-producing countries in 2017 for bauxite, Guinea had in place an export tax of 2%, and India an export tax of 15% along with a captive mining measure. China eliminated an export quota in 2013. For alumina, no restrictive measures to exports were imposed by the major producing countries in 2017. For unwrought aluminium, China applied an export tax of 15% in 2017, for both HS6 codes 760110 and 760120. An export tax of 1.25% imposed to exports of unwrought aluminium alloys (HS 760120) by the Russian Federation was effective until August 2016 (OECD 2019a).

### 3.2.1 Outlook for supply and demand

Consumption of bauxite and alumina follows the trend of aluminium production closely. World consumption of alumina for non-metallurgical uses is expected to increase slightly, attributable to continued growth in consumption of aluminium-hydroxide-based fire retardant materials and other alumina-based chemicals. Demand for high-purity alumina for devices such as smartphones, laptops, and tablets is also expected to continue to increase, although the effect on the total demand for bauxite and alumina would be marginal because of the limited volume of this market relative to aluminium smelting. Also, new entrants to the high-purity alumina market are expected to use high-alumina

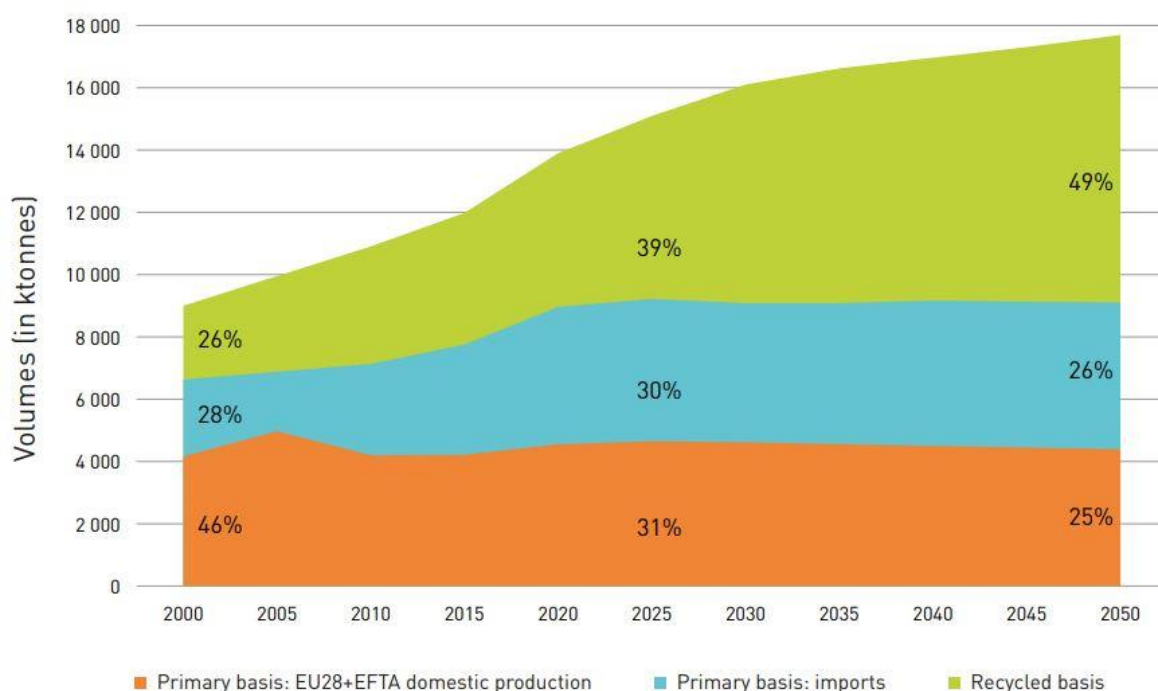
<sup>14</sup> Estimation based on average LME price of high-grade aluminium in 2016 (EUR 1,471 per tonne) and the global primary Al production in 2016 of 58,649 kt. Value of recycled aluminium production is not included.

clay instead of bauxite as the raw material for their processes, as higher purity levels can be obtained using high-alumina clay (USGS 2019a).

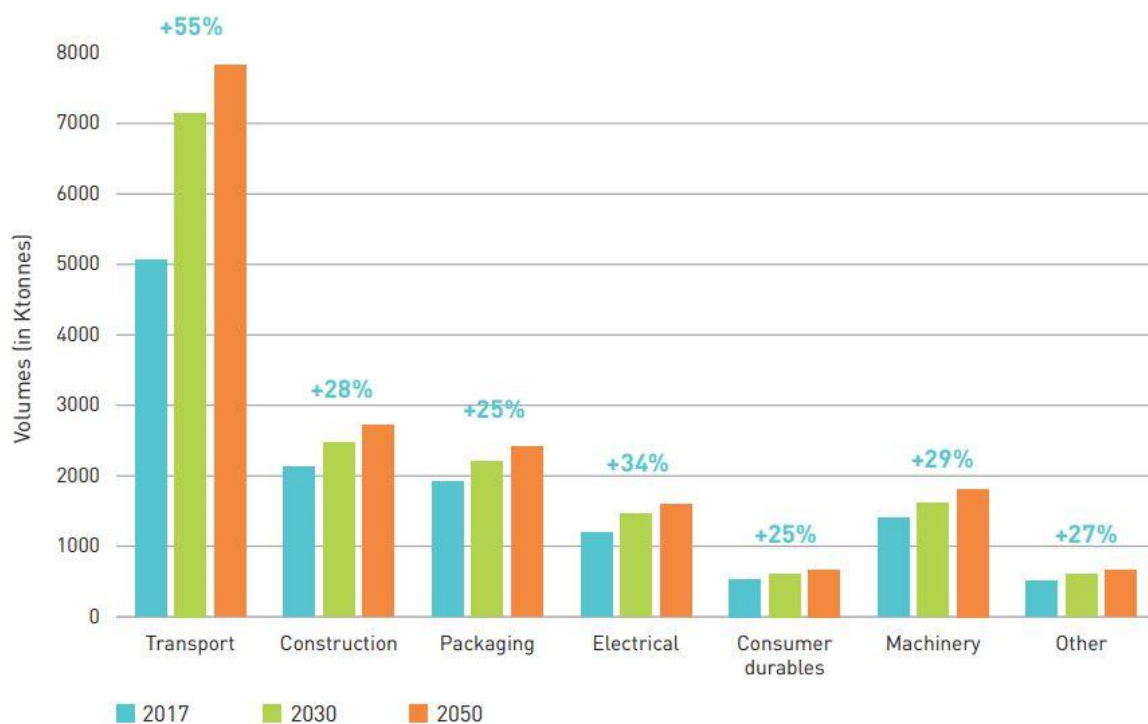
World demand for aluminium is expected to increase as the global economy continues to expand and aluminium products become more accessible to consumers in developing economies (USGS 2019a). Demand for aluminium is driven by the light-weighting trend in mobility, the need for energy-efficient buildings and light packaging and other applications (e.g. engineered products) (Dessart and Bontoux 2017).

According to published data in a recent European Aluminium Association’s report (CRU data in (European Aluminium 2019e)), world demand for primary aluminium is expected to increase by 50% by 2050, approaching 108 million t per year in 2050. European (EU28 + EFTA) demand for primary aluminium is forecasted to reach 9 million t. Chinese demand is expected to peak at almost 50 million t per year around 2035; by 2050, China will have a 40% share of primary aluminium demand. The most rapid growth is projected to be in India, which is going to replace China in terms of expansion of demand for primary aluminium by the mid-2030s, growing from 4% to 16% of global demand.

Europe is the second-largest consumer of primary aluminium and is likely to remain so until at least 2050. The total European aluminium ingot demand in 2050 will reach nearly 18 million t, and it will be met by almost equal shares of primary (production + imports) and recycled aluminium production (see Figure 30 and Figure 31). In a baseline scenario of the future primary aluminium production in Europe, domestic production of primary aluminium is expected to meet around 25% of the aluminium ingot demand by 2050. The average growth rate of semi-finished aluminium consumption is forecasted to 39% from 2017 to 2050. The main growth drivers of aluminium consumption in Europe will be increasing demand in applications where aluminium’s unique properties make it the material of choice, i.e. transport (up 55% compared to 2017), construction (up 28% compared to 2017) and packaging (up 25% compared to 2017) (CRU data in (European Aluminium 2019e)).



**Figure 30: Forecast of primary production in Europe (EU28+EFTA) (2000-2050) (CRU datasets in (European Aluminium 2019e)).**



**Figure 31: Demand by end use sector in Europe (EU28 + EFTA) from 2017-2050 (CRU datasets in (European Aluminium 2019e)).**

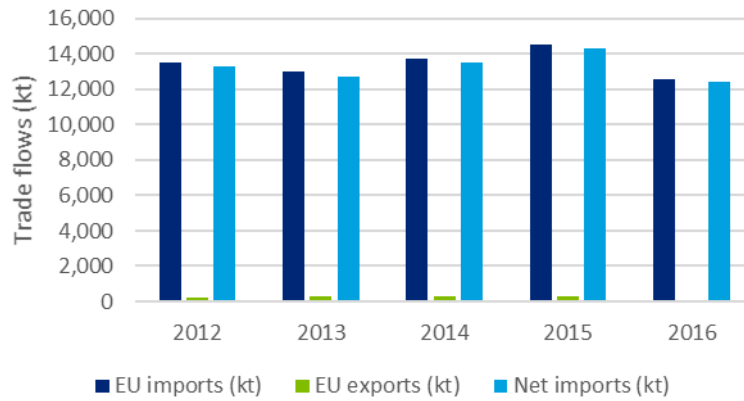
Table 13 summarises that the supply and demand of both aluminium and bauxite are expected to grow in the future.

**Table 13: Qualitative forecast of supply and demand of aluminium and bauxite**

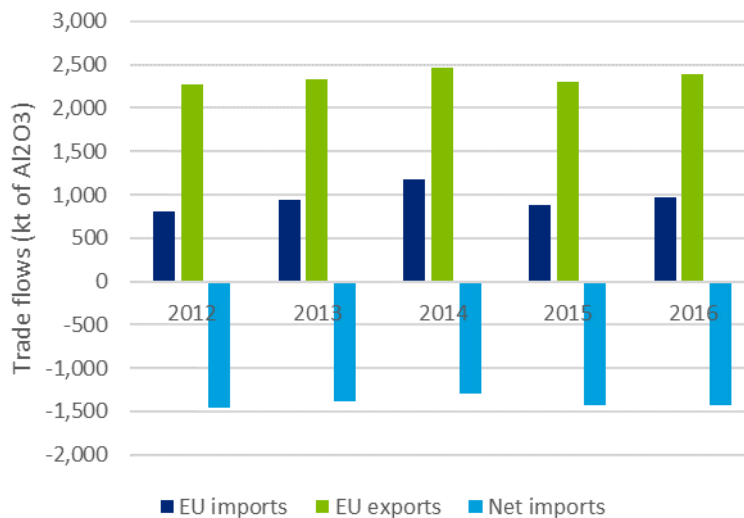
Materials	Criticality of the material in 2020		Demand forecast			Supply forecast		
	Yes	No	5 years	10 years	20 years	5 years	10 years	20 years
Bauxite	X		+	+	+	+	+	+
Aluminium		X	+	+	+	+	+	+

### 3.2.2 EU trade

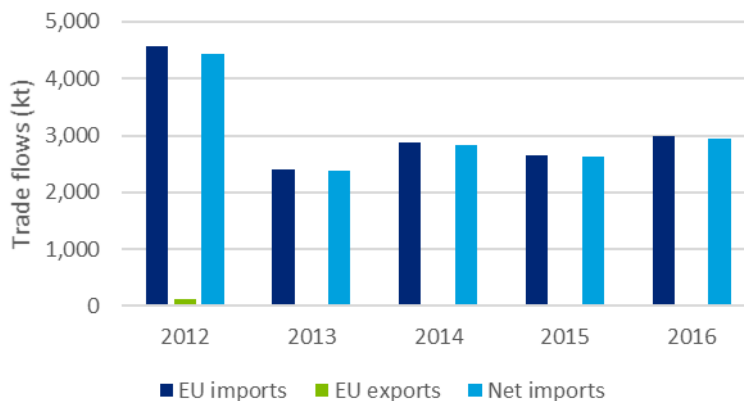
Although the EU does produce over 2,009 kt of bauxite per year and 2,131 kt of primary aluminium per year (averaged over 2012–2016). These figures are small compared to the scale of imports: 13,656 kt for bauxite and 3,176 kt for primary aluminium, as an average for the 2012-2016 period. Exports of bauxite (259 kt), and export of primary aluminium (56 kt) are considerably smaller compared to imports. Figure 32 presents the trade flows for bauxite and Figure 34 for primary aluminium. In contrast, the EU is a net exporter for alumina: 2,120 kt of  $Al_2O_3$  exports and 910 kt of  $Al_2O_3$  imports, as an average for the 2012-2016 period) (Figure 33).



**Figure 32: EU trade flows for bauxite (Eurostat Comext 2019)**



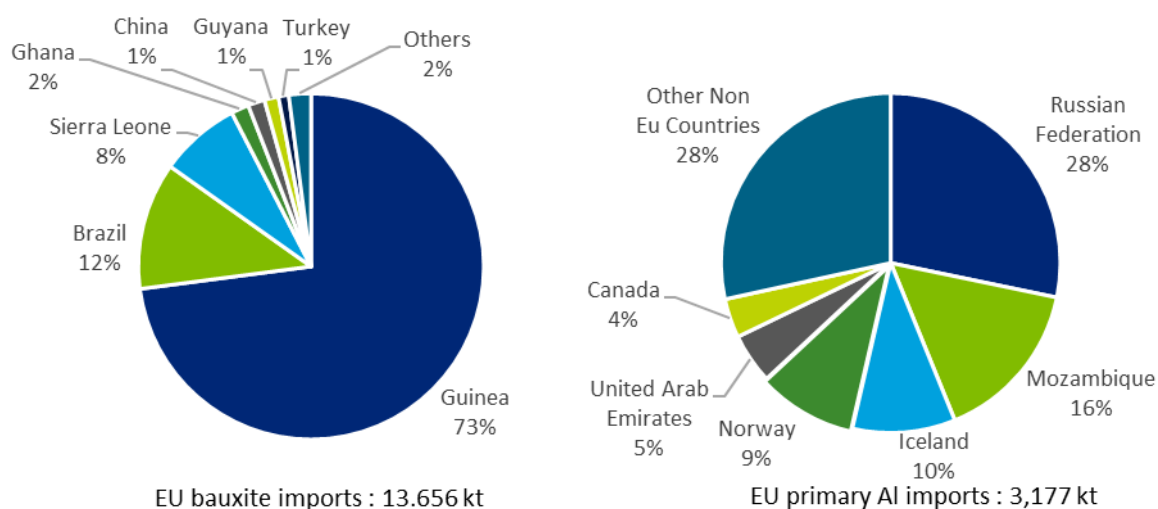
**Figure 33: EU trade flows for alumina<sup>15</sup> (Eurostat Comext 2019)**



**Figure 34: EU trade flows for primary aluminium (Eurostat Comext 2019)**

<sup>15</sup> Trade codes: HS 281820 'Aluminium oxide (excl. Artificial corundum)', HS 281830 'Aluminium hydroxide'. Trade flows of aluminium hydroxide are converted to Al<sub>2</sub>O<sub>3</sub> content

The countries of origin of imports of bauxite and primary aluminium are shown in Figure 35. For bauxite, the EU is dependent mainly on Guinea for its supplies with an average of 9,959 kt imported from that country per year. Imports from Brazil<sup>16</sup> amounted to approximately 1,623 kt per year, and from Sierra Leone to 1,036 kt per year. Imports of primary aluminium were more evenly distributed. The leading suppliers were Russia (an average of 897 kt per year), Mozambique (495 kt), Iceland (311 kt), and Norway (300 kt). As before these figures are all averaged over 2012–2016.



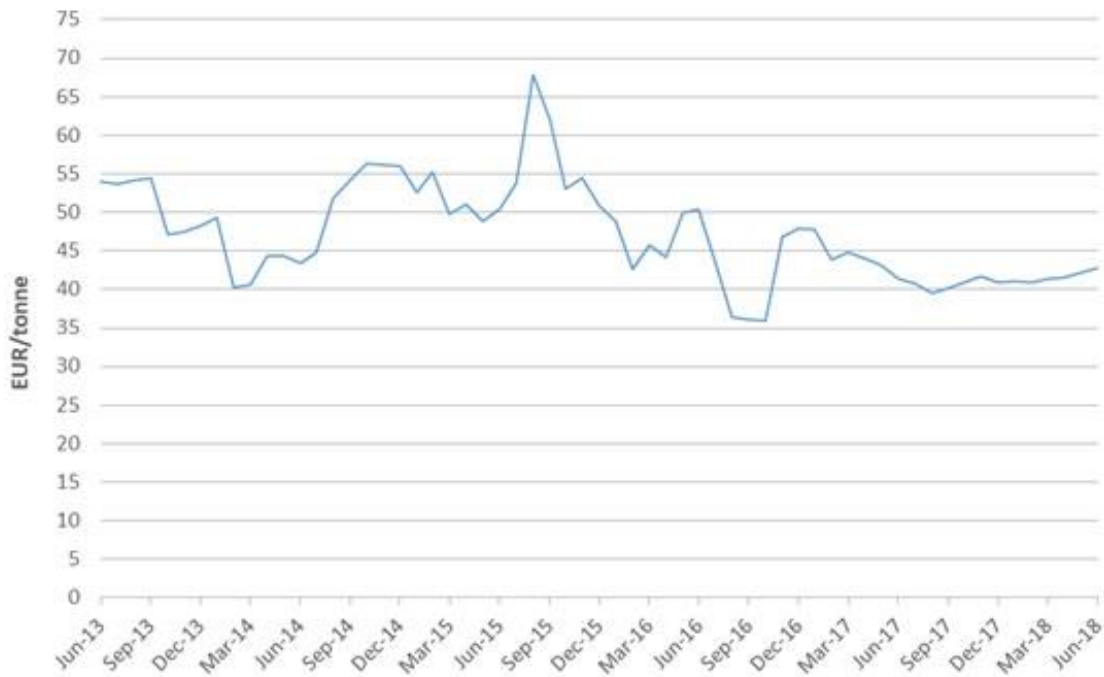
**Figure 35: EU imports of bauxite (left) and primary aluminium (right). Average 2012-2016 (Eurostat Comext 2019)**

Guinea, the main exporter and principal supplier of bauxite to the EU, has an export tax of 2%, in force since 2011. The leading exporters of unwrought aluminium to the EU applied no export restrictions in 2017. A tax of 1.25% applied by the Russian Federation to exports of unwrought aluminium alloys is no longer in effect since September 2016 (OECD, 2019a). Norway and Iceland, two of the important exporters of primary aluminium to the EU, are part of the European Economic Area agreement (EEA) which is in place since 1994 (European Commission 2019). Canada is part of the Comprehensive Economic and Trade Agreement (CETA) which is entered into force provisionally in 2017. Finally, the EU signed an Economic Partnership Agreement (EPA) on 10 June 2016 with the Southern African Development Community (SADC). Among other countries, the agreement comprises Mozambique, a significant exporter of primary aluminium to the EU, which started applying the EPA in February 2018 (European Commission 2019).

### 3.2.3 Prices and price volatility

Metallurgical-grade bauxite is mainly traded under long-term contracts, and the prices for these are generally not published (USGS 2018a). Spot prices for speciality forms of bauxite and alumina for non-metallurgical applications are published by trade journals (USGS 2018a). From June 2013 to June 2018, bauxite prices in China ranged from EUR 36 to EUR 68 per t, with an average of EUR 47 per t (see Figure 36).

<sup>16</sup> The EU has concluded a trade agreement with the four founding members of Mercosur (Argentina, Brazil, Paraguay, and Uruguay) as part of a bi-regional Association Agreement. <https://ec.europa.eu/trade/policy/countries-and-regions/regions/mercosur/>



**Figure 36: Bauxite price trend, CIF Qingdao port, monthly average (€/t). Data from (S&P Global Market Intelligence 2018)**

The alumina market was priced as a percentage of the London Metal Exchange (LME) aluminium price in the past, and some companies still use long-term LME-based contracts. Since 2010, the market has moved to use indices of spot prices calculated by price-reporting agencies based on transactions in the physical market, because of the changing dynamics of the LME and the alumina market and the increased cost of caustic soda (Fastmarkets MB 2019). LME launched a new cash-settled futures contract of alumina on March 2019 settled against CRU Alumina Price Index and the Fastmarkets MB Alumina FOB Australia Index by equal weighting to each index (Fastmarkets MB 2019)(LME 2019). The Chicago Mercantile Exchange (CME) also has an exchange-traded futures contract based on the Fastmarkets MB Alumina Fob Australia index (CME Group 2019).

Alumina prices have been relatively stable from 2011 to early 2017, as a percentage of LME aluminium price. According to CRU data, the CRU Alumina Price index (API) has been the 17% of the LME aluminium price on average. In 2017 and 2018, alumina price surged driven by market tightness caused by production disruptions at Hydro’s Alunorte alumina refinery, and sanctions against UC Rusal (Thomas 2018), traded on some occasions at 30% of the outright aluminium price. Throughout 2018’s escalation in alumina prices, the LME aluminium price became disconnected from the market, and instead of increasing in line with the raw materials, the aluminium price remained flat (Fastmarkets MB 2019b).

Aluminium is an exchange-traded commodity, listed in two exchanges: London Metal Exchange (LME) and the Shanghai Futures Exchange (SHFE).

- LME: All primary aluminium contracts globally (excluding China) are traded on the LME with a base price that is listed daily. LME prices are determined on the basis of global supply and demand. On top of the LME base price, an additional market premium is negotiated between buyer and seller for physical material contracts across the value chain. The market premiums account for the manufacturing of value-added products depending on the shape, alloy and other aspects, the delivery location to reflect costs associated with transaction and transportation from storage warehouses to downstream plants, the existing tariff status, and other contractual services. The LME base price is not negotiated

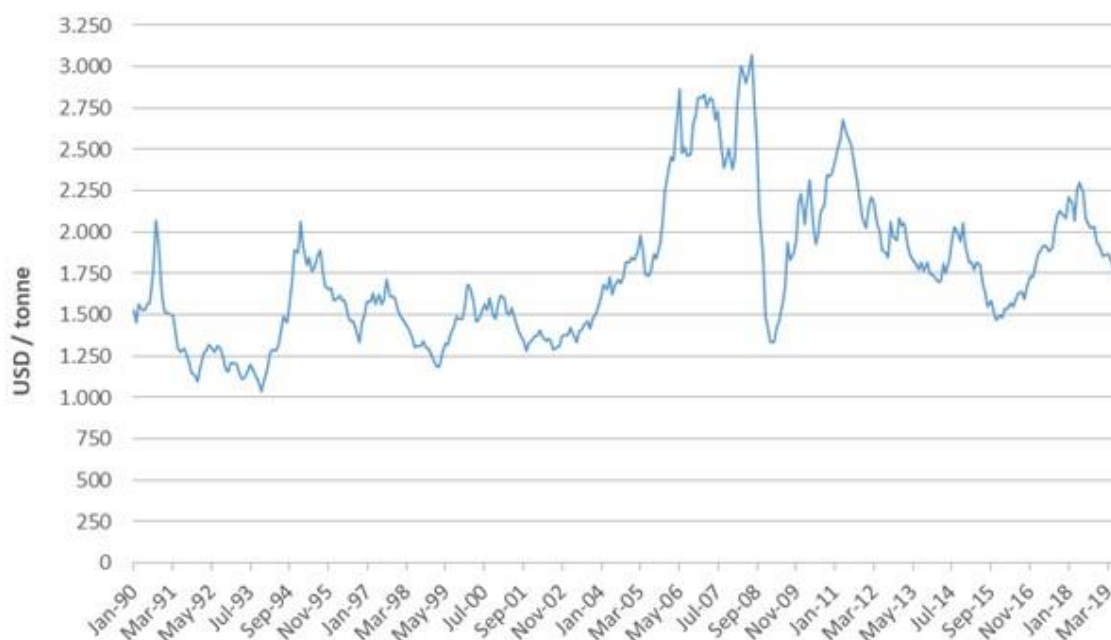


between the buyer and seller as it is the global reference point. For example, the all-in price of the metal a wrought producer may charge includes the prevailing LME exchange cost for the relevant volume of aluminium along with the premium fee (European Aluminium 2018c) (USITC 2017) (London Metal Exchange 2017);

- SHFE: Aluminium base prices in China are set on the SHFE, where only Chinese companies can trade aluminium (European Aluminium 2018c).

Both in LME and SHFE paper transactions represent much higher movements than physical ones. Therefore, speculators' anticipations of potential global movements are reflected in prices (Aluminum Association et al. 2018).

After its peak in spring 2008, aluminium's price collapsed by almost 50%, and recovery started in early 2009. However, world market prices for primary aluminium have remained significantly lower than the levels reached in 2008 (Figure 37). China is increasing its aluminium-smelting capacity continuously, accounting for more than half of the world's supply since 2013, which has caused the decline of prices worldwide not only of primary aluminium but also of downstream semi-finished and finished aluminium products exported by China (EC 2018b).



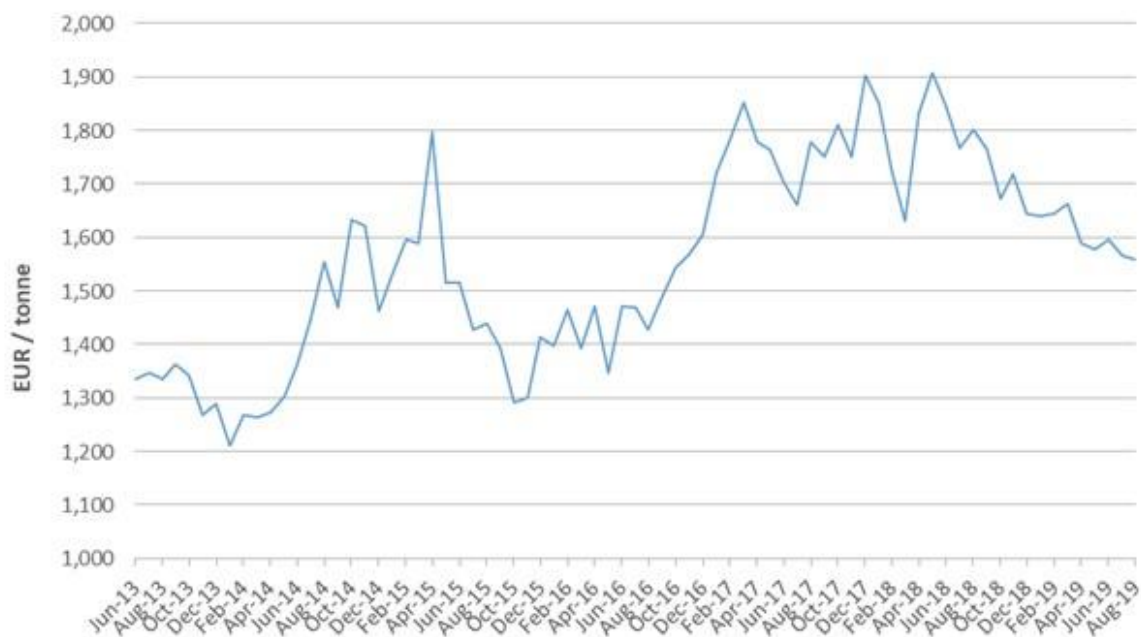
**Figure 37: Monthly London Metal Exchange (LME) aluminium settlement<sup>17</sup> price<sup>18</sup>, unalloyed primary ingots of a minimum 99.7% purity, in USD/t. (World Bank 2019)**

In real terms, the average annual aluminium price (LME settlement price) declined by 38% from 2007 to 2016 (World Bank 2019). In 2017, the average annual LME settlement price of aluminium increased to USD 1,968 per t; a price increase of 19% since 2016, driven by winter closures and supply reform in China (Thomas 2018). Nevertheless, the average annual aluminium price in 2019 remained approximately 27% lower in real terms in comparison to 2007. The short-term peak observed in April 2018 was the result of US sanctions imposed to the world's second-largest aluminium producer (Rusal), and the widespread uncertainty caused in the international aluminium market. The monthly aluminium price at the LME rose to almost USD 2,600 per t (EUR 1907 per t), which

<sup>17</sup> Settlement price beginning 2005; previously cash price

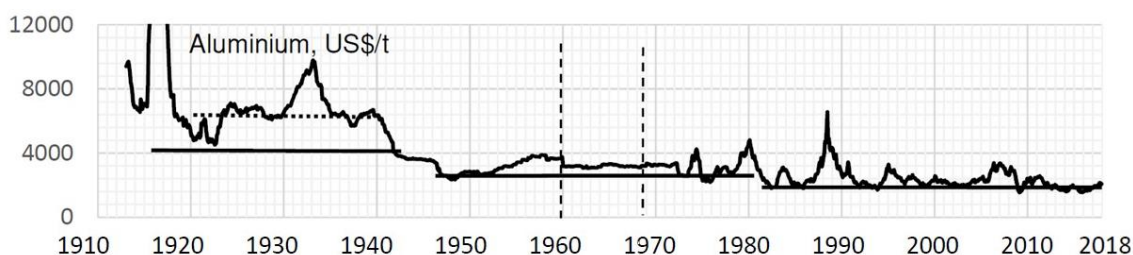
<sup>18</sup> Nominal prices, not adjusted for inflation

marked a 6-year high (DERA 2018). Since then, world aluminium prices are generally declining, and the monthly LME-cash price dropped to USD 1,724 per t (EUR 1,558 per t) in August 2019 (see Figure 38).



**Figure 38. Monthly London Metal Exchange (LME) aluminium price<sup>19</sup> (99.7% cash), in EUR/t (S&P Global Market Intelligence 2019)**

Figure 39 shows aluminium long term prices from 1910 to 2018. It shows real prices, lower and upper real price benchmarks (solid line for real price, solid horizontal line for lower real price benchmark, dashed line for upper real price benchmark, real prices deflated by using US PPI, basis 2017, vertical dashed line indicates break in price specification) (Buchholz, 2019).



**Figure 39: Long term prices for Aluminium. USD per t. (Buchholz et al., 2019)**

### 3.3 EU demand

#### 3.3.1 EU consumption of bauxite

The EU apparent consumption of bauxite between 2012 and 2016 is calculated at about 15,406 kt per year. Of this 1,750 kt per year came from within the EU (calculated as EU production minus exports to non-EU countries) with the remaining 13,656 kt imported from outside the EU. Based on these figures, it is not surprising that the net import reliance for the EU is high at 87% (averaged over 2012-2016).

<sup>19</sup> Not adjusted for inflation

### 3.3.2 Uses and end-uses of bauxite in the EU

The majority (95%) of bauxite mined worldwide is refined into alumina, and the remainder (5%) is consumed directly for non-metallurgical applications. The share of bauxite output which is converted to alumina for the production of aluminium metal (smelter-grade) ranges from 85% to 89%, while the proportion used for the production of alumina for other applications (chemical-grade) is reported to vary from 6% to 10% (V. Hill and Sehnke, 2006) (Flook, 2015). Non-metallurgical applications of bauxite, including those of chemical-grade alumina, are found in refractories, cement, abrasives and chemicals.

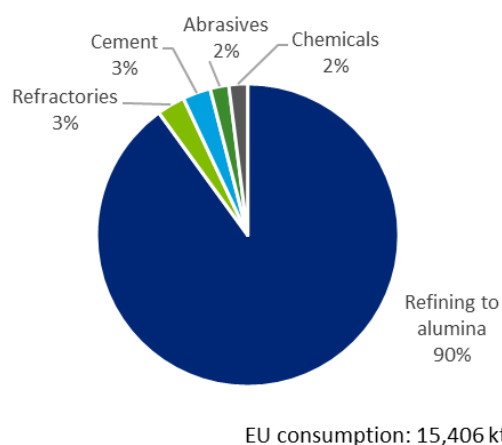
Refractory-grade bauxite or sintered chemical-grade alumina are used for the manufacture of high-alumina refractories, mainly for the iron and steel industry (Flook 2015).

Aluminous cement is used where rapid strength and/or resistance to certain types of corrosion are required. Calcined chemical grade alumina is required for the production of high-purity alumina cement for castable monolithic refractories.

In abrasives, calcined bauxite and calcined speciality-grade alumina are used for the manufacture of abrasive materials for grinding.

The chemical uses of bauxite include the production of aluminium sulphate (used as a flocculating agent in water or effluent treatment), aluminium chloride, and aluminium fluoride or sodium aluminate. Bauxite applications in ceramic proppants for oil and gas drilling fluids, in welding fluxes, as slag adjuster and in road surfacing are included under this category.

The main categories of end uses for bauxite between 2012 and 2016 are shown in Figure 40.



**Figure 40: Global end uses of bauxite (International Aluminium Association and literature; SCRREEN workshops 2019), and EU consumption of bauxite (average 2012-2016) (WMD 2019; Eurostat Comext 2019)**

The relevant industry sectors are described using the NACE sector codes in Table 14.

**Table 14: Bauxite applications, 2-digit and associated 4-digit NACE sectors, and value-added per sector (Eurostat 2019)**

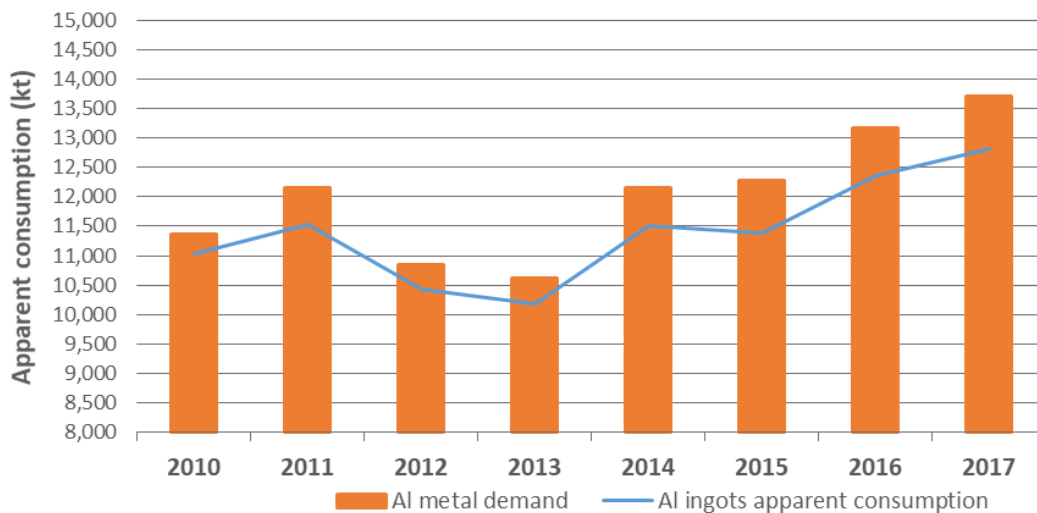
Applications for bauxite	2-digit NACE sector	Value-added of NACE 2 sector (millions €)	4-digit NACE sector(s)
Refining to alumina	C24 – Manufacture of basic metals	55,426	C2442 – Aluminium production
Refractories	C23 – Manufacture of other non-metallic mineral products	57,255	C2320 – Manufacture of refractory products

Cement	C23 – Manufacture of other non-metallic mineral products	57,255	C2351 – Manufacture of cement
Abrasives	C23 – Manufacture of other non-metallic mineral products	57,255	C2391 – Production of abrasive products
Chemicals	C20 – Manufacture of chemicals and chemical products	105,514	C2013 – Manufacture of other inorganic basic chemicals

### 3.3.3 EU consumption of aluminium

For primary aluminium, the EU apparent consumption is calculated at 5,252 kt per year (average 2012-2016) and of this 2,075 kt came from within the EU (again calculated as EU production minus exports to non-EU countries). The remaining 3,177 kt were imported from outside the EU, resulting in net import reliance of 59% averaged over 2012-2016.

Figure 41 demonstrates the aluminium ingots apparent consumption by the EU industry in comparison with the total aluminium metal demand from 2010 to 2017, as they are derived from official statistics (Eurostat).



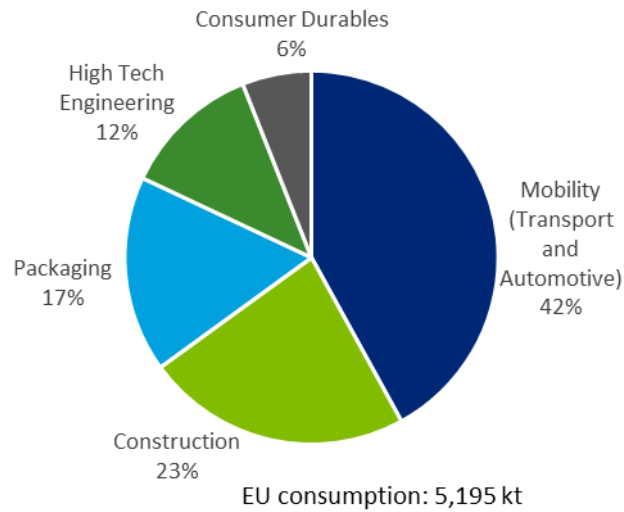
**Figure 41: Aluminium ingots apparent consumption<sup>20</sup> and aluminium metal demand<sup>21</sup>**

### 3.3.4 Uses and end-uses of aluminium in the EU

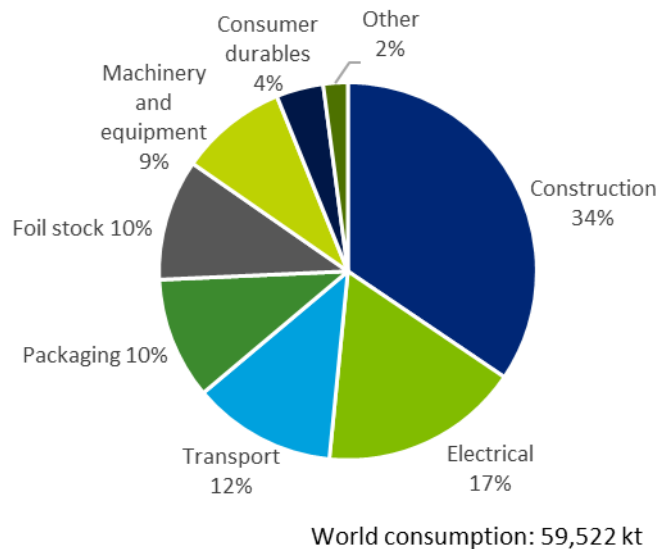
Figure 42 shows the EU end uses of aluminium in 2017, and Figure 43 presents the end uses of aluminium worldwide in 2015.

<sup>20</sup> Calculated as domestic production of unwrought aluminium (PRODCOM codes PRC 24421130, PRC 24421154) plus net imports of unwrought aluminium (HS 760110, HS 760120). It is necessary to note that in the criticality assessment, primary aluminium is analysed, and not unwrought aluminium

<sup>21</sup> Calculated as domestic production of unwrought aluminium plus net imports of unwrought aluminium (HS 760110, HS 760120), semi-finished aluminium products (HS 7604-HS 7609), powders and flakes (HS 7603) and castings and forgings (HS 761699)



**Figure 42: Main end uses of aluminium in Europe in 2017 (European Aluminium 2018), and EU consumption of primary aluminium (average 2012-2016)**



**Figure 43: World consumption of aluminium by major end-use sectors, 2015. (CRU data in (USITC 2017))**

Aluminium’s excellent combination of properties together with its relative cost-effectiveness have led to its widespread use in a variety of applications (OECD 2015). The following paragraphs provide some examples because there is insufficient space in this factsheet to list them all.

The largest market for aluminium in Europe is the transport sector (see Figure 42) where the metal is used in the manufacture of road vehicles (cars, buses, trucks), trains, aircraft, ships, spacecraft, bicycles, etc. Within a vehicle, aluminium is sometimes used for body panels, but it is also used for engine blocks, transmission housings, wheels, radiators, cylinder heads, heat exchangers, pistons, etc. Although aluminium often represents less than 10% of the total quantity of materials utilised in a car, due to its favourable strength to weight ratio its use can significantly reduce weight with consequent improvements in fuel consumption. The second example of this sector is the use of aluminium in aircraft

where its lightness, workability and strength make it an ideal material. Some of the most common aircraft models in the world today are 70–80% aluminium.

Within the *construction sector* can be found in a multitude of applications. Essential uses are in manufacturing doors, windows, cladding, roofing, staircases, air conditioning units, solar protection, parts of internal walls and other components. Aluminium retains its useful properties for long periods, which means it is beneficial for architects in designing buildings.

Aluminium is one of the most versatile forms of *packaging*, as it can be formed into almost any shape. It is mainly used to protect food, drinks and pharmaceutical products against damage from light, liquid, temperature or bacteria, and it is non-toxic. By type of aluminium packaging, flexible packaging (wraps, plain foil, lidding, household foil etc.) represents 28% of the market, semi-rigid packaging 18% (trays and other food containers), and rigid packaging 54% (beverage and food cans, aerosol cans, closures, tubes, etc.) (European Aluminium 2014).

High-tech engineering includes mechanical engineering applications such as pistons, cylinder blocks, pulleys, guide rails, optical equipment, pneumatic cylinders, measuring instruments, etc. It also comprises electrical and heat transfer engineering applications such as power cables, ladders, cable sheathing, heat exchangers, busbars (electrical conductors), cooling fins, etc.

Aluminium is also widely used to manufacture *consumer durables* such as cooking utensils, watches, the outer casing of some types of equipment (e.g. photographic equipment, smartphones, tablet computers, etc.), electrical appliances, LED lighting, paints, alloys for some coins, cookers, boilers, sports equipment, mirrors and reflectors, etc. As an example, aluminium utensils are easy to wash, corrosion-resistant, not easily damaged, and the material is an excellent heat conductor allowing heat to spread evenly through a cooking pan.

The relevant industry sectors are described using the NACE sector codes in Table 15.

**Table 15: Aluminium applications, 2-digit and examples of associated 4-digit NACE sectors, and value-added per sector (Eurostat 2019)**

<b>Applications for primary aluminium</b>	<b>2-digit NACE sector</b>	<b>Value-added of NACE 2 sector (M€)</b>	<b>Examples of 4-digit NACE sector(s)</b>
Mobility (Transport and Automotive)	Both C29 – Manufacture of motor vehicles, trailers and semi-trailers,  AND  C30 – Manufacture of other transport equipment	160,603  AND  44,304	C2910 – Manufacture of motor vehicles; C2920 Manufacture of bodies for motor vehicles; C2932 – Other parts for motor vehicles; C3030 – Manufacture of air and spacecraft; C3011 – Building of ships and floating structures; C3020 – Manufacture of railway locomotives and rolling stock; C3092 – Manufacture of bicycles

<b>Applications for primary aluminium</b>	<b>2-digit NACE sector</b>	<b>Value-added of NACE 2 sector (M€)</b>	<b>Examples of 4-digit NACE sector(s)</b>
Construction	C25 – Manufacture of fabricated metal products, except machinery and equipment	148,351	C2511 – Manufacture of metal structures and parts of structures; C2512 – Manufacture of doors and windows of metal; C2599 – Manufacture of other fabricated metal products n.e.c.
Packaging	C25 – Manufacture of fabricated metal products, except machinery and equipment	148,351	C2592 – Manufacture of light metal packaging
High-Tech Engineering	C28 – Manufacture of machinery and equipment not elsewhere specified	182,859	C2811 – Manufacture of engines; C2812 – Manufacture of fluid power equipment; C2893 – Manufacture of machinery for food processing; C2529 – Manufacture of tanks, reservoirs and containers of metal; C2732 – Manufacture of other electronic and electrical wires and cables.
Consumer Durables	C25 - Manufacture of fabricated metal products, except machinery and equipment	148,351	C2571 – Manufacture of cutlery

### 3.3.5 Substitution

Alumina production from non-bauxite sources is theoretically possible from nepheline concentrates, and commercial production has been reported in Russia (Vadim Smirnov 1996)(Jorjani and Amirhosseini 2007). However, information is limited on the costs, performance and production levels. Other potential bauxite substitutes for the supply of alumina are anorthosite, alunite, low-grade kaolin and clay, and coal fly ash (Kuzvart 2006). In particular, anorthosite, which is abundantly available worldwide, has been evaluated with success as a source of aluminium ore in Norway, but the process developed was not commercially compatible with existing bauxite-based alumina production (Wanvik 2000). The project AlSiCal funded by Horizon 2020 (September 2019–August 2023) is going to research further the technology for producing alumina from anorthosite which generates no bauxite residues (CORDIS 2019). In general, no evidence was found to suggest that bauxite substitution with the above potential substitutes is currently carried out on a commercial scale. Substitutes for other applications were not considered in the assessment as their application shares were less than 10% each. However, refineries were under feasibility studies or construction worldwide in 2015 to produce high-purity (99.99%) alumina from high-alumina clays, therefore substituting bauxite (USGS 2016).

For aluminium, a variety of substitutes were assessed. Steel is considered the primary substitute material for aluminium in mobility, construction, packaging and machinery applications (Graedel et al. 2015b).

For the mobility applications (transport and automotive), composites such as carbon-fibre-reinforced plastic have been successfully used for many applications, e.g. in cars, fuselages and wings of aeroplanes, but the cost is currently significantly higher than aluminium (USGS 2019) (Rao et al. 2018). Titanium and magnesium are also possible substitutes in this sector. Steel is the only one of these materials with lower cost to aluminium. However, steel is heavier than aluminium, and consequently, for specific applications, the performance could be lower (USGS 2019) (Djukanovic 2016) (Musfirah and Jaharah 2012).

In the construction sector, additionally to steel, plastics (such as PVC or vinyl) and wood were considered as possible substitutes. In all cases, the cost and performance were assessed to be similar to aluminium.

Glass, plastics and steel are potential substitutes for aluminium for packaging applications, and again for all of these, the performance was considered to be similar, and costs same or lower.

In the high-tech engineering application, copper can replace aluminium in electrical lines for power transmission and distribution, as well as in heat-exchange applications, but the current costs of copper are higher than aluminium. Cast iron and cast steel may also substitute aluminium in specific applications at similar cost and performance.

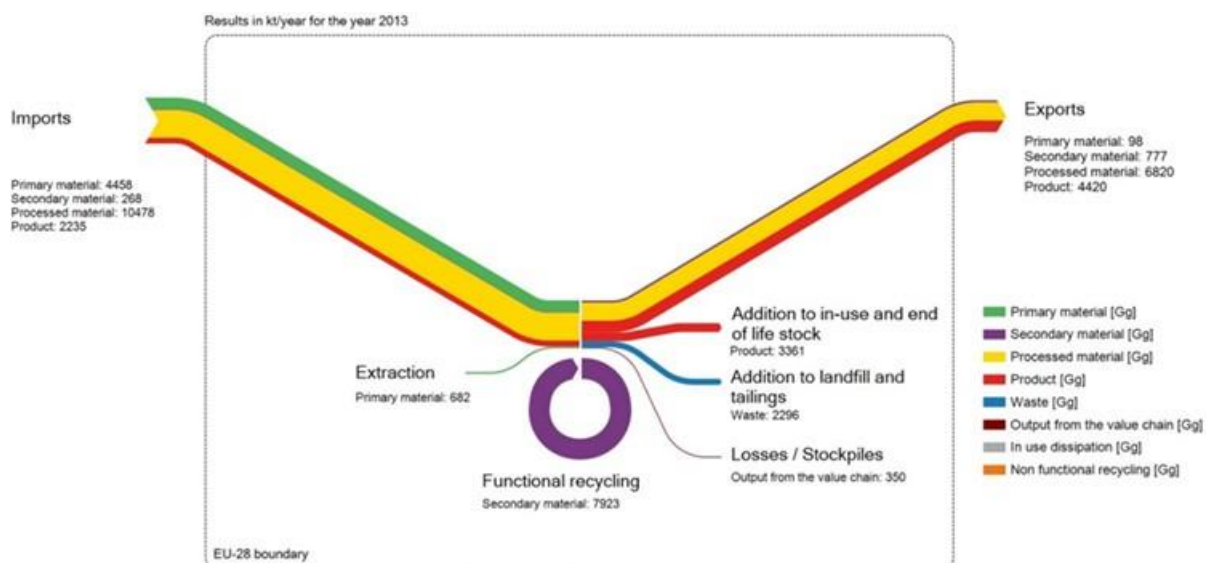
Potential substitutes for consumer durables were not assessed as this application sector represents less than 10% of aluminium demand. However, copper can substitute aluminium in cooking utensils and home appliances (e.g., refrigerators) (Graedel et al. 2015b).



## 3.4 Supply

### 3.4.1 EU supply chain

The aluminium flows through the EU economy in 2013 are shown in Figure 44.



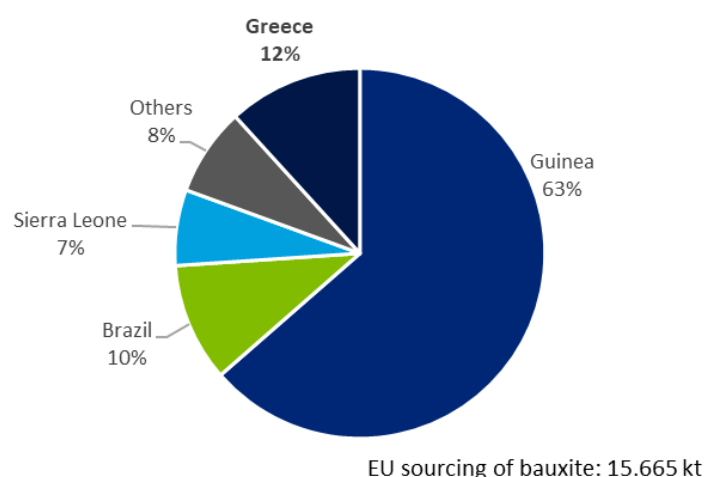
**Figure 44: Simplified MSA of aluminium flows in the EU in 2013 (Passarini et al. 2018)**

#### 3.4.1.1 EU sourcing of bauxite

Within the EU, bauxite was mined between 2012 and 2016 in four countries, but the combined output from these countries (about 2,000 kt per year) represents less than 1% of the world's total production of bauxite. EU production is small when compared to the overall global production of more than 281,000 kt per year, or compared to the largest producing country: Australia (80,092 kt per year).

Greece is the leading EU bauxite producer, with a yearly output of nearly 1,850 kt, averaged over 2012-2016. Operating mines are located in the Parnassos-Giona zone in Central Greece, and are owned by Mytilineos Holdings SA and Imerys Industrial Minerals Greece (Vassiliadou 2015) (S&P Global Market Intelligence 2019b). 90% of the mining of bauxite in Greece takes place in underground exploitations and 10% in opencast ones (Mining Greece 2019). Small quantities of bauxite are also mined in Hungary and France (around 80 kt per year each) and Croatia (under 9 kt per year).

In addition to domestic production, more than 13,656 kt per year of bauxite are imported to the EU. Of these imports, 33% go to Ireland, with another 26% imported by Spain, 18% by Germany, 9% by Romania, 8% by France, and 3% by Greece. EU's net import reliance between 2012-2016 was 87% for bauxite. Figure 45 presents the EU sourcing (domestic production + imports) of bauxite.



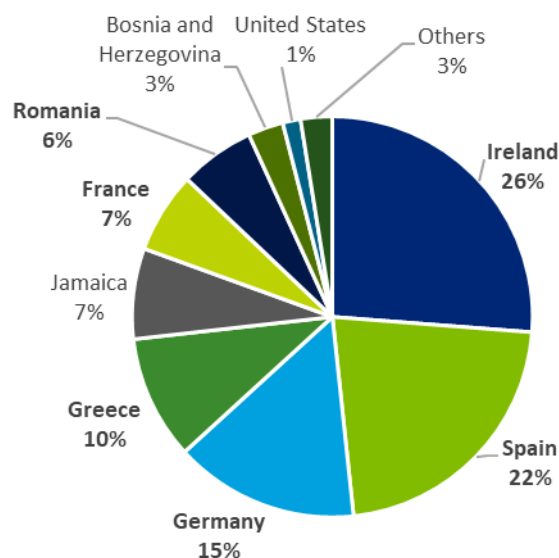
**Figure 45: EU sourcing of bauxite. Average 2012-2016 (WMD 2019; Eurostat Comext 2019)**

### 3.4.1.2 EU sourcing of alumina

Table 16 presents the active alumina refineries in 2018 in six EU countries. The EU output averaged 5,793 kt in Al<sub>2</sub>O<sub>3</sub> content over 2012–2016 contributing to about 5% of the global production of alumina. Imports to the EU totalled 910 kt in Al<sub>2</sub>O<sub>3</sub> content and as an average over the same period. Figure 46 provides the EU sourcing (domestic production + imports) for alumina.

**Table 16. Operating alumina refineries in the EU by capacity in 2018. Data from (Balomenos 2019), (S&P Global Market Intelligence 2019a), companies' websites.**

Plant	Country	Operator	Ownership	Annual capacity (kt)	Products
Aughinish	Ireland	Aughinish Alumina Ltd	United Co. RUSAL Plc	1,990	Smelter-grade
San Ciprián	Spain	Alcoa World Alumina and Chemicals (AWAC)	Alcoa Corp. (60%), Alumina Ltd (40%)	1,500	Smelter-grade, hydrated alumina
Stade	Germany	Aluminium Oxid Stade (AOS) GmbH	Dadco Alumina & Chemicals Ltd	1,050	Smelter-grade, specialty aluminas
Agios Nikolaos	Greece	Aluminium of Greece	Mytilineos Holdings S.A.	850	Smelter-grade, hydrated alumina
Gardanne	France	ALTEO	H.I.G. Capital Europe	635	Specialty aluminas
Tulcea	Romania	ALUM	Vimetco N.V., Bayraktar Holding (Alro)	500	Smelter-grade, hydrated alumina
Total				6,525	



EU sourcing of alumina : 6,704 kt of Al<sub>2</sub>O<sub>3</sub>

**Figure 46: EU sourcing of alumina. Average 2012-2016. Production data from (BGS 2019a) and trade flows<sup>22</sup> from (Eurostat Comext 2019)**

### 3.4.1.3 EU sourcing of primary aluminium

As regards primary aluminium, in 2018 there are fifteen active aluminium smelters in nine countries in the EU, contributing about 4% to world production. Production levels averaged over 2012–2016 data, vary between 504 kt in Germany to 47 kt in the Netherlands. These figures are rather small when compared to the global total of 54,628 kt per year, or compared to China, the largest producing country with more than 28,336 kt per year.

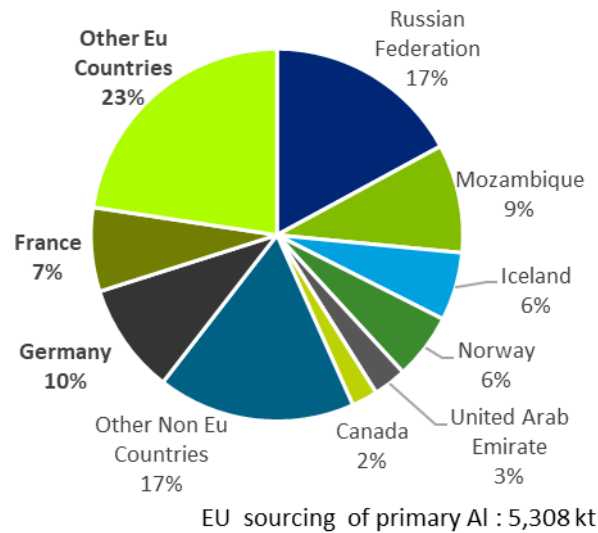
**Table 17. Operating primary aluminium smelters in the EU by capacity in 2018. Data from (Light Metal Age 2019), (S&P Global Market Intelligence 2019a), companies' websites.**

Plant	Country	Operator	Ownership	Annual capacity (kt)	Shutdown Capacity (kt)
Dunkerque	France	Liberty Aluminium Dunkerque	GFG Alliance	285	-
Slatina	Romania	SC Alro SA	Vimetco N.V.	282	-
San Ciprian	Spain	Alcoa Europe	Alcoa Corp.	250	22
Rheinwerk Neuss	Germany	Hydro Aluminium Deutschland GmbH	Norsk Hydro ASA	230	80

<sup>22</sup> Trade codes: HS 281820 'Aluminium oxide (excl. Artificial corundum)', HS 281830 'Aluminium hydroxide'. Trade flows of aluminium hydroxide are converted to Al<sub>2</sub>O<sub>3</sub> content

<b>Plant</b>	<b>Country</b>	<b>Operator</b>	<b>Ownership</b>	<b>Annual capacity (kt)</b>	<b>Shutdown Capacity (kt)</b>
Žiar nad Hronom	Slovakia	Slovalco AS	Norsk Hydro ASA (55.3%), Slovalco Invest, a. s. (44.7%)	175	-
Essen	Germany	TRIMET Aluminium SE	TRIMET Aluminium SE	170	-
Delfzijl	Netherlands	Aluminium Delfzijl BV (Aldel)	Damco Aluminium Delfzijl Coöperatie U.A.	111	-
Agios Nikolaos	Greece	Aluminium of Greece	Mytilineos Holdings S.A.	190	-
St Jean de Maurienne	France	TRIMET France	TRIMET Aluminium SE	145	-
Hamburg	Germany	TRIMET Aluminium SE	TRIMET Aluminium SE	135	-
Sundsvall	Sweden	Kubikenborg Aluminium AB (Kubal)	United Co. RUSAL Plc	130	-
Voerde	Germany	TRIMET Aluminium SE	TRIMET Aluminium SE	96	-
Aviles	Spain	Alcoa Inespal SA	Alcoa Corp.	93	27
La Coruña	Spain	Alcoa Inespal SA	Alcoa Corp.	87	26
Kidricevo	Slovenia	Talum d.d.	ELES	85	-
Total				2,464	155

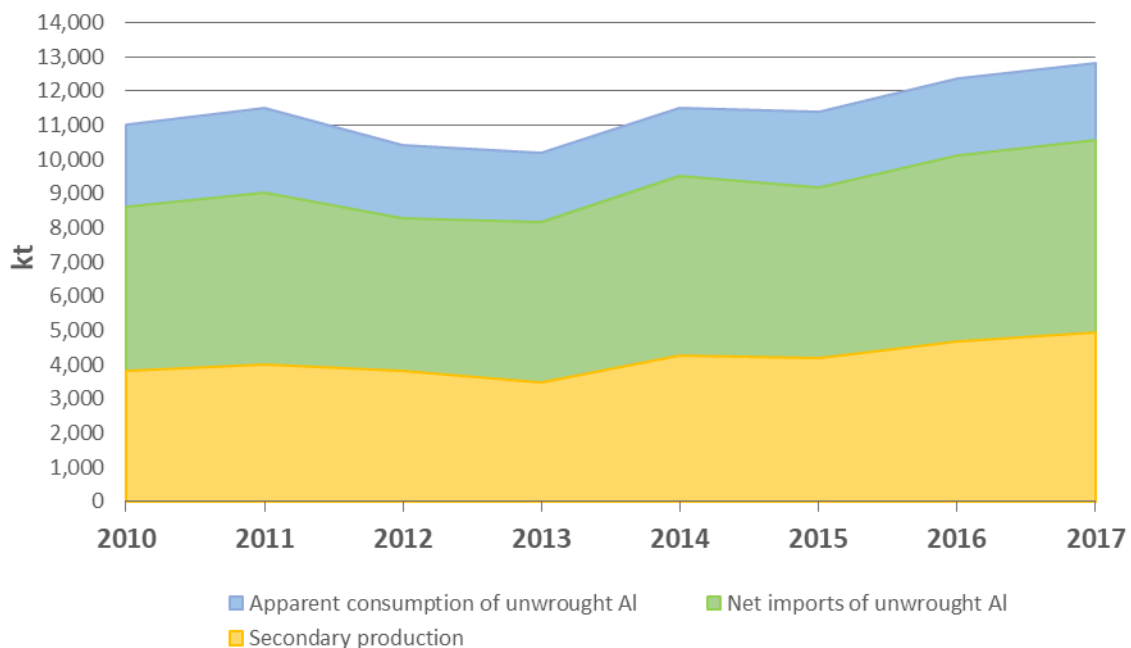
In addition to the total EU production of primary aluminium of nearly 2,132 kt per year, a further 3,178 kt per year of primary aluminium was imported into the EU (average 2012-2016). The net import reliance is 59% for primary aluminium. Figure 47 presents the EU sourcing (domestic production + imports) of primary aluminium.



**Figure 47: EU sourcing of primary aluminium. Average 2012-2016 (WMD 2019; Eurostat Comext 2019)**

#### 3.4.1.4 EU supply of recycled aluminium

The European Aluminium Association reports that the number of recycling plants in Europe was 220 in 2015, many of which are small and medium-sized enterprises (SMEs) (European Aluminium 2016). Over a third of EU consumption in aluminium ingots is satisfied by recycling of old and new scrap (Figure 48).



**Figure 48: Contribution of secondary production and net imports to the EU consumption of unwrought Al (ingots). Background data<sup>23</sup> from (Eurostat Prodcom, 2019) (Eurostat Comext, 2019)**

<sup>23</sup> The apparent consumption of unwrought Al is calculated from official Eurostat data for shipments and net imports. PRC codes used for production (sold) of unwrought Al: 24421153 and 24421155 from 2010 to 2012; 24421130 and 24421154 from 2013 to 2017. CN codes for trade flows of unwrought Al: CN 76011000, CN 76012000 and CN 76011080. The

## 3.4.2 Supply from primary materials

### 3.4.2.1 Geology, resources and reserves of bauxite

**Geological occurrence:** Aluminium is the most common metallic element, making up approximately 8% of the Earth's crust, and the third most abundant element after oxygen and silicon. In the upper crust, the abundance of  $\text{Al}_2\text{O}_3$  is 15.4 wt% (Rudnick and Gao 2014) (V. Hill and Sehnke 2006). Although aluminium occurs in a wide range of minerals (mainly oxides and silicates), it is too reactive to occur naturally. Therefore, it is challenging to extract aluminium from most of the minerals in which it is present. Bauxite is the only ore used for the commercial extraction of aluminium, which may contain 40-60% aluminium oxide (Aluminum Association 2007).

Bauxite is a heterogeneous rock composed of a wide variety of minerals. The bauxite ores consist primarily of the aluminium hydroxides gibbsite (65%  $\text{Al}_2\text{O}_3$ ), boehmite and diasporite (each around 85%  $\text{Al}_2\text{O}_3$ ), or their mixtures, with varying proportions of silica, iron oxides, titania, aluminosilicates and other impurities. Each of these three types of bauxite has different characteristics that make them more or less desirable for mining and metallurgical purposes (Vassiliadou 2015).

Deposits of bauxite are residual accumulations caused by intense lateritic weathering. Most bauxite deposits can be classified into two categories: those developed over carbonate rocks (karst bauxite); and those developed over other types of rocks (lateritic bauxite). The karst bauxites occur predominantly in the Caribbean (e.g. Jamaica), Mediterranean (e.g. Greece, France), China, Central Urals and Kazakhstan. The lateritic bauxites which are the major source for world's production are found mostly in Africa (e.g. Guinea), South Asia (e.g. India), Australia, North and South America (e.g. Guyana) (V. G. Hill and Sehnke 2006).

**Global resources and reserves<sup>24</sup>:** Globally, the United States Geological Survey (USGS, 2018b) estimates that known resources of bauxite are in the range of 55–75 billion t, in Africa (32%), Oceania (23%), South America and the Caribbean (21%), Asia (18%), and elsewhere (6%). USGS notes that because the aluminium element is so abundant across the world, there are "essentially inexhaustible" quantities in materials other than bauxite. However, these are currently not economical to extract and therefore should not yet be included in any estimates of resources.

The world's known bauxite reserves are estimated by USGS at about 30 billion t. A total of 90% of these are concentrated as large blanket deposits in tropical and subtropical regions where bauxite typically occurs in extensive, relatively thin near-surface layers (layer thickness generally is 4-6 metres) (IAI 2019a). Guinea has the largest known bauxite reserves globally (25%), followed by Australia (20%), Vietnam (12%) and Brazil (9%). Global reserves of bauxite are sufficient to last at least another 100 years at the

---

secondary production is estimated by subtracting primary production from the total unwrought Al production, and may not reflect secondary ingot production by integrated casthouses.

<sup>24</sup> There is no single source of comprehensive evaluations for resources and reserves that apply the same criteria to deposits of bauxite in different geographic areas of the EU or globally. The USGS collects information about the quantity and quality of mineral resources but does not directly measure reserves, and companies or governments do not directly report reserves to the USGS. Individual companies may publish regular mineral resource and reserve reports, but reporting is done using a variety of systems of reporting depending on the location of their operation, their corporate identity and stock market requirements. Translations between national reporting codes are possible by application of the CRIRSCO template, which is also consistent with the United Nations Framework Classification (UNFC) system. However, reserve and resource data are changing continuously as exploration and mining proceed and are thus influenced by market conditions and should be followed continuously.

rate of extraction in 2016 (WMD 2019; USGS 2018b). The breakdown per counties is given in Table 18.

**Table 18: Global reserves of bauxite in 2017 (USGS 2018b)**

Country	Bauxite Reserves (million t)	Percentage of the total (%)
Guinea	7,400	25.0
Australia	6,000	20.0
Vietnam	3,700	12.0
Brazil	2,600	9.0
Jamaica	2,000	7.0
China	1,000	3.0
Indonesia	1,000	3.0
Guyana	850	3.0
India	830	3.0
Russia	500	2.0
Greece	250	1.0
Saudi Arabia	210	1.0
Kazakhstan	160	1.0
Malaysia	110	1.0
United States	20	1.0
Other countries (unspecified)	3,200	11.0
World total (rounded)	30,000	100

**EU resources and reserves**<sup>25</sup>: According to USGS (2018b), the largest exploitable deposits of bauxite in the EU are located in Greece with estimated reserves of 250 million t. The most important known exploitable deposits are located in the zone of mountains Helikon-Parnassus-Giona-Iti, where reserves are estimated at approximately 100 million tonnes (Vassiliadou 2015) (Tsirambides and Filippidis 2012). The Minerals4EU (2019) project published bauxite resources and reserves data for some EU countries. Of these, only Romania reported statistical data in compliance with the United Nations Framework Classification (UNFC) system of reporting. Data cannot be summed as they are partial, and they do not use the same reporting code.

---

<sup>25</sup> For Europe, there is no complete and harmonised dataset that presents total EU resource and reserve estimates for bauxite. The Minerals4EU project is the only EU-level repository of some mineral resource and reserve data for fluorspar, but this information does not provide a complete picture for Europe. It includes estimates based on a variety of reporting codes used by different countries, and different types of non-comparable datasets (e.g. historic estimates, inferred reserves figures only, etc.). In addition, translations of Minerals4EU data by application of the CRIRSCO template is not always possible, meaning that not all resource and reserve data for bauxite the national/regional level is consistent with the United Nations Framework Classification (UNFC) system (Minerals4EU 2019). Many documented resources in Europe are based on historic estimates and are of little current economic interest. Data for these may not always be presentable in accordance with the UNFC system. However, a very solid estimation can be done by experts.

**Table 19: Bauxite resources data for the EU (Minerals4EU 2019)**

Country	Reporting code	Quantity (million t of bauxite)	Grade (% Al <sub>2</sub> O <sub>3</sub> )	Classification
France	None	432	NA	Historic resource estimate
Greece	USGS	130	35-40	Indicated
	USGS	240	NA	Inferred
Hungary	Russian Classification	5.28	NA	A
	Russian Classification	9.73	NA	B
	Russian Classification	72.19	NA	C1
	Russian Classification	36.73	NA	C2
Romania	UNFC	97	NA	333
Italy	None	1.25	NA	Sub-Economic

**Table 20: Bauxite reserves data for the EU**

Country	Reporting code	Quantity (million t of bauxite)	Grade (% Al <sub>2</sub> O <sub>3</sub> )	Classification	Source
Greece	None	250	NA	NA	(USGS 2018b)
Romania	UNFC	2.5	NA	121	(Minerals4EU) 2019
Italy	None	1	NA	Estimated	Minerals4EU 2019

### 3.4.2.2 Exploration and new mine development projects in the EU

No active exploration projects are reported in the EU (S&P Global Market Intelligence 2019b). The H2020 "Smart Exploration" (2019) research project targets the Gerolekas bauxite exploration site in Greece.

### 3.4.2.3 Bauxite mining

For bauxite extraction, conventional surface mining techniques are commonly applied. Bauxite does not require complex beneficiation because the ore grade is usually already sufficient; simple mineral processing techniques (crushing, washing and screening) are only needed to remove clay and fine sands before shipment to alumina refineries or other markets (IAI 2019a).

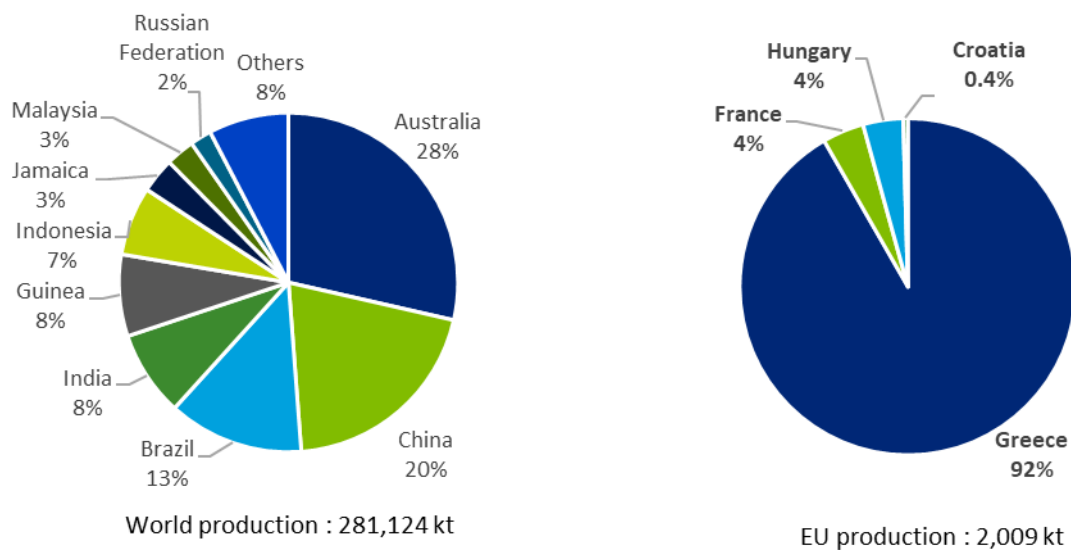
Bauxite is typically classified according to its intended commercial application, e.g. metallurgical, abrasive, cement, chemical etc. Of all bauxite mined, in 2014 about 95% is refined to alumina for aluminium smelting and other uses, and the remainder (5%) is used directly for non-metallurgical bauxite applications (V. Hill and Sehnke 2006)(Flook 2015).

### 3.4.2.4 World and EU mine production of bauxite

Globally bauxite was mined in 32 countries in 2016 with total production averaged over the 2012–2016 period to more than 281,123 kt per year. Figure 49 demonstrates the most significant producers. Australia is the leading producer and accounts for 28% of the world total. China (20%), Brazil (13%), India (8%) and Guinea (8%) are other important producers and together with Australia hold a 77% share of world mine production.



The EU annual production of bauxite (average 2012-2016) is about 2,009 kt. 92% of the EU production was mined in Greece (0.7% of world total, 92% of EU production); much lower bauxite quantities were extracted in Hungary, France and Croatia (<0.1% each of global total) (WMD 2019).



**Figure 49: Global and EU mine production of bauxite. Average for the years 2012-2016 (WMD 2019)**

### 3.4.3 Alumina refining

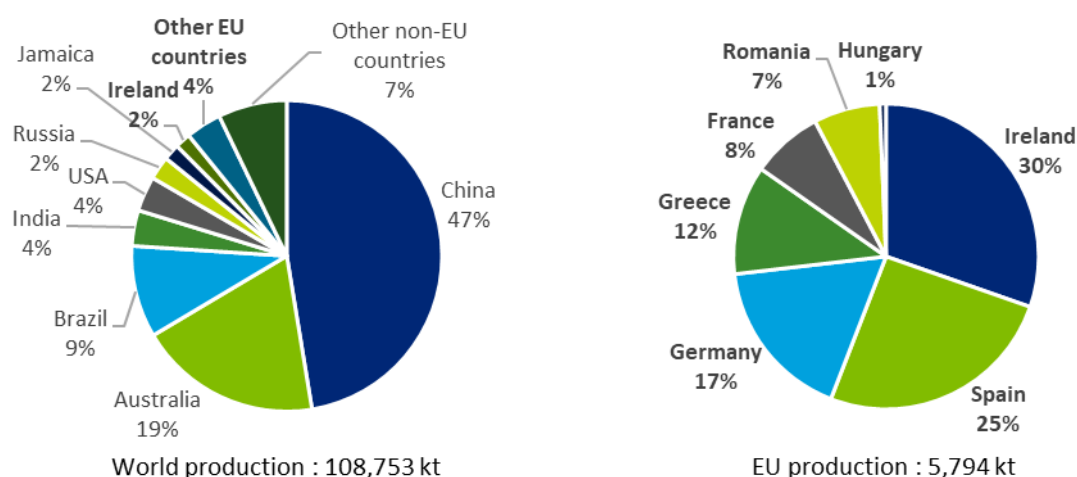
The bulk of world bauxite production is used as feed for the manufacture of alumina (aluminium oxide,  $Al_2O_3$ ) via a wet chemical caustic leach process known as the Bayer process. Typically, 2-3 t of bauxite are required to produce one t of alumina. At the refinery, the bauxite is washed and milled to reduce the particle size, and any excessive silica is removed. Hot caustic soda is added to dissolve the aluminium-bearing minerals (gibbsite, boehmite and diaspore) to form a saturated solution within a digester at temperatures of between 140°C and 280°C depending on the type of ore. The slurry is then rapidly cooled in a series of flash tanks to around 106°C and a chemical flocculant added to assist in the sedimentation of the solid bauxite residue so that it can be removed from the saturated solution in settling tanks and filters. Next, the saturated solution is progressively cooled under controlled conditions, and aluminium trihydrate precipitates as crystals; with a chemical formula of  $Al(OH)_3$  this is also known as 'alumina hydrate'. These crystals are separated from the remaining liquor using vacuum filtration, and calcined at 1,100 °C to form alumina (IAI 2019a).

The produced alumina can be classified as smelter-grade for aluminium smelting, or chemical-grade for other applications. Smelter-grade alumina represents a share of 89-94% of the total alumina output (Flook, 2015) (V. Hill and Sehnke, 2006). The chemical-grade alumina can be further distinguished to speciality calcined alumina grades and alumina trihydrate, with a market share of 45% and 55%, respectively (Flook 2015).

#### 3.4.3.1 World and EU production of alumina

The annual average output of alumina amounted 108,752000 kt over the period 2012-2016. The largest producer was China (47% of the worldwide total in 2016), followed by Australia (19%) and Brazil (9%). Within the EU there are alumina refineries in France,

Germany, Greece, Ireland, Romania and Spain (Hungary ceased production in 2015), with a combined total of almost 5,794 kt that amounts to 5% of the global total.



**Figure 50: Global and EU production of alumina. Average for the years 2012-2016 (BGS 2019)**

### 3.4.4 Aluminium smelting

Primary aluminium is obtained from the electrolytic smelting of alumina (aluminium oxide,  $Al_2O_3$ ) into molten aluminium metal by means of the Hall-Héroult process. This involves passing an electrical current (direct current at 600,000 ampere) into a line of electrolytic cells, or 'pots', connected in a series known as a 'potline'. Each pot is a large carbon-lined container, which forms the cathode of the cell. Inside the pot is an electrolytic bath of molten cryolite at a temperature of 960–980°C into which the alumina powder is dissolved. Aluminium fluoride is added to the solution to optimise the chemistry. Carbon blocks are suspended in the solution to serve as the anode. The electrical current is passed from the anode via the electrolytic bath to the cathode and then on to the anode of the next pot in the series. As it passes through the bath, the dissolved alumina is split into molten aluminium and oxygen. The molten aluminium metal sinks to the bottom of the pot from where it is siphoned every day or two in a process known as 'tapping'. Typically 15,000 kilowatts of electricity and 1.9 t of alumina are required to produce one t of aluminium metal (IAI 2019c) (IAI 2019b)(OECD 2015).

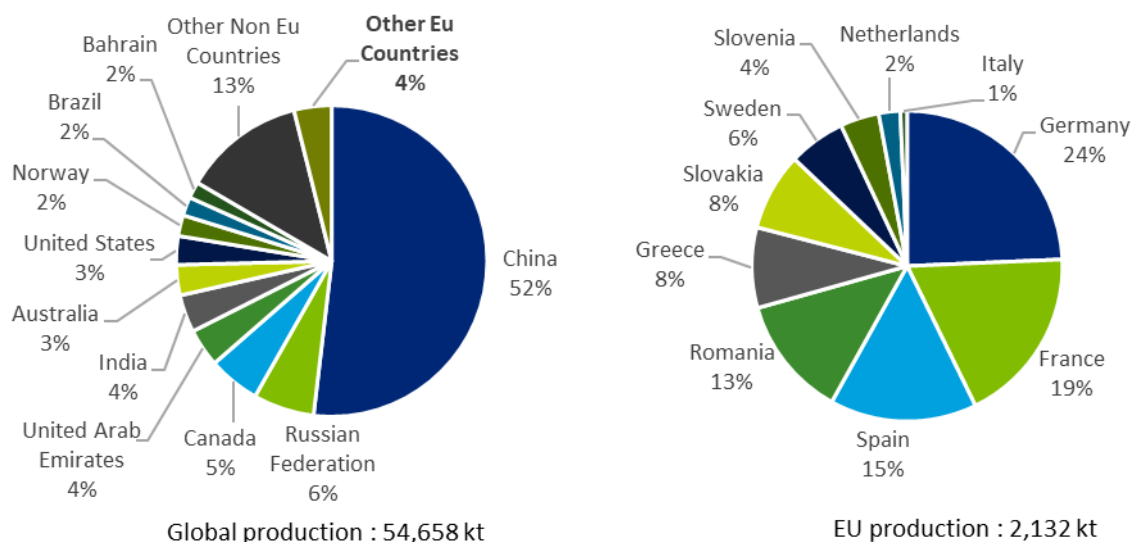
Molten aluminium is either sold directly to customers or transferred to the casthouse, where it is purified, alloyed if necessary and cast into various unwrought products. Forms of unwrought primary aluminium shipped to customers include T-bars, ingots for rolling, extrusion ingots (or billets), continuously cast strips, ingots for forging, ingots for castings (or foundry alloys), pigs, sows, wire rod etc. These shapes are then fabricated into semi-finished products (flat rolled-products, extrusions, wire, etc.) and subsequently into finished goods (Bertram et al. 2017)(USITC 2017).

#### 3.4.4.1 World and EU production of primary aluminium

The global primary aluminium production over the 2012–2016 period totalled to an average of 54,658 kt per year. The largest world producers are shown in Figure 51. China accounts for 52% of the world's production of primary aluminium. Russia (7%), Canada (5%), United Arab Emirates (4%) and India (4%) are following on the list of major producers (WMD 2019).

Within the EU for 2012-2016, there were aluminium smelters in Germany, France, Spain, Romania, Greece, Slovakia, Sweden, Slovenia, Netherlands and Italy. These contributed

a total of nearly 2,132 kt of aluminium (4% of the global total), based on figures averaged over 2012–2016. Since 2012, the Italian smelter is closed.



**Figure 51: Global and EU production of primary aluminium. Average for the years 2012-2016 (WMD 2019)**

### 3.4.5 Supply from secondary materials/recycling

Bauxite is consumed during all of its uses and therefore is not available for recycling. Although some refractory products are subsequently recycled, this is generally to further refractory applications and is very small in quantity compared to the global production of bauxite. The majority of bauxite uses results in a substance that is subsequently transformed into a different product, e.g. cement into concrete or alumina into aluminium metal (SCREEN workshops 2019).

Aluminium is infinitely recyclable without downgrading its quality. Secondary aluminium is produced by melting aluminium scrap. The scrap utilised in secondary aluminium production consists of 'new scrap' which is generated during the production and fabrication of wrought and cast products, and 'old scrap' which is recovered from articles at the end of their useful life such as used beverage cans, packaging etc.

Recycling of aluminium needs as little as 5% of the energy originally used for its primary production, with obvious financial and environmental benefits. More than one-third of all the aluminium produced globally originates from scrap. According to the European Aluminium Association, 37% of the aluminium ingot needs in Europe in 2017 were covered by recycled aluminium (European Aluminium 2019b). The high value of aluminium scrap is a key incentive and significant economic stimulus for recycling (IAI 2009).

While the end-of-life recycling rate (EoL-RR) for aluminium is high, old scrap generally makes up a relatively small share of overall material input to the EU (Passarini et al. 2018). The increasing demand for aluminium, coupled with the long-life of many applications (e.g. buildings, mobility) prevents recycled production from covering the demand, making primary production still necessary (Dessart and Bontoux 2017).

#### 3.4.5.1 Post-consumer recycling (old scrap)

End-of-life scrap ('old scrap') is defined as scrap arising from products that have been used but are no longer required because they have been worn out or become obsolete. For aluminium, this includes a wide range of products including aluminium beverage cans

or food packaging; components from aircraft, cars or other vehicles; articles arising from the demolition of buildings such as window profiles; or discarded equipment (European Commission 2017). Post-consumer scrap has to be collected and sorted before it can be recycled. According to European Aluminium (2016), EoL-RR in Europe for aluminium used in transport and buildings was over 90%, whereas 60% of the aluminium used in packaging was recycled in 2013. The recycling rate for aluminium beverage cans in the EU, Switzerland, Norway and Iceland reached an all-time record of 74.5% in 2017 (European Aluminium 2019a).

The aluminium industry produces recycled aluminium at 'remelters' and 'refiners', as well as in internal melting and casting facilities ('cast houses'). Remelters supply rolling mills and extruders with rolling ingots or extrusion billets (wrought alloys) for further processing, and refiners supply foundries with casting ingots (casting alloys) and the steel industry with deoxidants (IAI 2009)(European Aluminium 2016). Aluminium scrap is used as an input, including new (pre-consumer) scrap (e.g. cut-off ends, turnings) from manufacturing and casting processes and old (post-consumer) scrap from durable and nondurable products (e.g. used beverage cans, window frames).

Recycling of old aluminium scrap involves the collection, sorting, pre-treatment, melting and casting. The most significant factors in determining the quantity of aluminium from 'old scrap' to be recycled are the collection systems for the wide-ranging end-of-life products and the long lifespan of some of the products. Estimates suggest that 75% of all aluminium ever produced is still in use (European Aluminium 2018b). Secondary aluminium production is characterized by the diversity of old scrap types available (a high variety of alloys, size, type and degree of contamination by paints, ink or plastics) which correspondingly determines the necessary pre-treatment technique (e.g. mechanical separation) and the melting process to be applied (e.g. rotary furnace with salt flux). In the secondary aluminium industry, 'refiners' produce casting alloys (e.g. for cast engine blocks) and 'remelters' produce wrought alloys (e.g. for sheets and extrusion) (European Aluminium 2016).

According to the MSA study of aluminium (2018), the end-of-life recycling input rate (EoL-RIR) was 12% in 2013 (SCRREEN workshops 2019). The EoL-RIR measures the quantity of end-of-life scrap (i.e. 'old scrap') contained within the total amount of metal available to manufacturers (which would also include primary metal and 'new scrap'). If the EU had processed domestically the flow of aluminium waste and scrap exported in 2015, the EoL-RIR would have increased to 16% (Passarini et al. 2018).

**Table 21: Material flows relevant to the EOL-RIR<sup>26</sup> of aluminium in 2013. Data from (Passarini et al. 2018)**

MSA Flow	Value (kt)
B.1.1 Production of primary material as main product in EU sent to processing in EU	495.523
B.1.2 Production of primary material as by-product in EU sent to processing in EU	0
C.1.3 Imports to EU of primary material	4,458.156
C.1.4 Imports to EU of secondary material	268.253
D.1.3 Imports to EU of processed material	10,478.176
E.1.6 Products at end of life in EU collected for treatment	4,337.805
F.1.1 Exports from EU of manufactured products at end-of-life	0
F.1.2 Imports to EU of manufactured products at end-of-life	0
G.1.1 Production of secondary material from post-consumer functional recycling in EU sent to processing in EU	2,209.139
G.1.2 Production of secondary material from post-consumer functional recycling in EU sent to manufacture in EU	0

### 3.4.5.2 Industrial recycling (new scrap)

Aluminium metal scrap and other aluminium-bearing wastes are also generated during the fabrication and manufacture of aluminium products (referred to as 'new scrap' or 'processing scrap'). This could be in the form of metal that did not meet required specifications, excess metal removed during casting or forging, grinding sludge or turnings generated during machining processes. The recycling of new scrap is more straightforward than for old scrap because it contains less contamination from other materials. New scrap constitutes the most significant source of secondary aluminium, representing about 70% of secondary material input in the EU in 2013 (Passarini et al. 2018).

## 3.5 Other considerations

### 3.5.1 Environmental, and health and safety issues

The most significant environmental concern related to the production of aluminium is greenhouse gas emissions (OECD 2015). Globally, approximately 40% of greenhouse emissions are the result of the aluminium production process itself (direct emissions), and around 60% relates to electricity generation for smelting (indirect emissions) (IAI 2009). As an energy-intensive industry, aluminium production covers the largest part of the EU greenhouse gas emissions of the non-ferrous metals sector, despite the considerable decrease of emissions achieved in the last years. Since 1990, the European primary aluminium production has reduced by 55% the direct CO<sub>2</sub> emissions per t. The European aluminium sector accounted in 2016 for around 1% of the verified emissions of all stationary installations of the EU and about 2% of its industrial emissions (European Commission 2018). Incremental improvements in energy efficiency will not be enough but will require breakthrough innovations in the smelting process to drastically reduce direct carbon emissions by 2050 (European Aluminium 2019e). New low-carbon technologies are under development in aluminium's production route, e.g. low emission electrolysis.

The shift to secondary production through further recycling could bring significant additional benefits, as the recycling of aluminium saves energy consumption by 95% and emissions up to 98% (European Commission 2018). Finally, a decarbonised power sector

<sup>26</sup> EOL-RIR=(G.1.1+G.1.2)/(B.1.1+B.1.2+C.1.3+D.1.3+C.1.4+G.1.1+G.1.2)

could further reduce the emissions of the aluminium industry (European Aluminium 2018b).

European Aluminium regularly publishes Life Cycle Inventory (LCI) data for the production of aluminium in EU-28 and EFTA countries (Norway, Switzerland and Iceland), verified by external experts. An updated Environmental Profile report was published in 2018 covering the entire aluminium value chain in Europe, from the metal supply (primary and recycling) to semi-fabrication (rolling, foil and extrusion). Based on 2015 production data, the report provides LCI datasets for the key process steps essential for calculating the environmental impacts of aluminium products fabricated in Europe. Among key findings are:

- The Global Warming Potential (GWP) for primary aluminium production in Europe decreased by 21% versus 2010. However, the overall environmental impact of the primary aluminium used in Europe remains relatively stable balanced by an equivalent increase in the environmental impact of imports. The carbon intensity of the primary aluminium production in Europe is approximately 7 kg CO<sub>2</sub>-eq per kg of aluminium produced compared to a global average of 18 kg CO<sub>2</sub>-eq per kg of aluminium; Since 2010, the Global Warming Potential (GWP) for the aluminium rolling mill process decreased by 25%, for the extrusion process decreased by 11% and for process scrap recycling reduced by 9% (European Aluminium 2018b).

EU OSH requirements exist to protect workers' health and safety, employers need to identify which hazardous substances they use at the workplace, carry out a risk assessment and introduce appropriate, proportionate and effective risk management measures to eliminate or control exposure, to consult with the workers who should receive training and, as appropriate, health surveillance<sup>27</sup>.

According to the CLP Regulation European Commission No 1272/2008, aluminium is classified as:

- Water-react. 2
- Pyr. Sol 1 or Flam. Sol. 1

### **3.5.2 Contribution to low-carbon technologies**

Aluminium can play a key role in low-carbon technologies and energy-efficient applications due to its specific properties such as lightweight, heat and electrical conductivity, corrosion-resistance, recyclability, and formability.

Due to its lightweight, improved fuel efficiency and carbon emissions reduction are achievable through increased aluminium use in transport without compromising safety, from passenger aircraft to cars. Aluminium replacing steel in car manufacture reduces the overall weight of the vehicle (Euromines 2019b). Also, aluminium used in buildings improves energy efficiency, notably via windows, curtain walls and ventilated facades (European Aluminium 2019c). The recyclability and durability of aluminium contribute further to the sustainability of buildings. Aluminium recycling rates from construction materials are in the order of 90% while aluminium use in buildings and construction offers long service life without maintenance (Eurometaux 2015)(European Aluminium 2019e). Moreover, aluminium is a material used in wind and solar power installations, as well as in charging infrastructure for electric vehicles (European Aluminium 2019e) (European Political Strategy Centre 2018). In wind turbines in particular, several tonnes of aluminium may be required in parts such as the gearbox, while materials based on aluminium honeycomb technology combining high strength and low weight may be used in blades and cores within wind turbines. In solar thermal systems, aluminium is used primarily in absorbers, casings and frames (Euromines 2019). Finally, aluminium becomes the

---

<sup>27</sup> <https://ec.europa.eu/social/main.jsp?catId=148>

preferred material for high and extra-high voltage submarine cables, which will play a significant role in connecting northern and southern Europe, ensuring a more liquid electricity market by transporting renewable energy to where it is needed (European Aluminium 2019e).

### 3.5.3 Socio-economic issues

Bauxite mines are commonly found in the tropical and sub-tropical area; thus deposits often overlap or are adjacent to, areas of high conservation value. Besides, bauxite mining and related activities usually take place on, or near, indigenous lands and local communities. Mining frequently requires access to large zones of land and water resources that sustain local communities (IAI, Australian Aluminium Council, and Brazilian Aluminium Association 2018).

The Performance Standard of the Aluminium Stewardship Initiative (ASI, 2019) includes principles for the respect of human rights especially in the context of local community relationships, resettlement, and cooperation with indigenous people, in order to obtain their free and informed consent before the approval of any project affecting their lands or territories.

Guinea, which holds the most extensive world reserves of bauxite, is the EU’s most important supplying country for bauxite and one of the top world exporters. Guinea has very weak governance (World Bank 2018), and the Human Development Index value for 2017 is very low (0.459), which positions the country at 175 out of 189 countries and territories in the low human development category (UNDP 2018). A report released by the Human Rights Watch (2018), focusing on the Guinea’s two largest mining projects, highlights the profound human rights consequences to local communities that live closest to the fast-growing bauxite mining industry such as damages to water sources, loss of farmlands, undermined air quality etc.

## 3.6 Comparison with previous EU assessments

The assessment has been conducted using the revised methodology introduced in the 2017 assessment. For bauxite, the calculation of the supply risk (SR) was carried out at the extraction stage of the value chain, and for primary aluminium at the processing stage, in both cases using both the global HHI and EU HHI calculation as prescribed in the methodology. No assessment has been made of the criticality of the intermediate stage between bauxite and primary aluminium, namely the production of alumina. The same stages for each material were evaluated in the 2017 exercise. It has to be noted that the assessment for aluminium does not address the aluminium ingot supply (i.e. aluminium metal), but only primary aluminium. The results of this and earlier assessments are presented in Table 22.

**Table 22: Economic importance and supply risk results for bauxite and aluminium in the assessments of 2011, 2014, 2017, 2020 (European Commission 2011)(European Commission 2014b)(European Commission 2017b)**

Assessment	2011		2014		2017		2020	
	EI	SR	EI	SR	EI	SR	EI	SR
Bauxite	9.5	0.3	8.5	0.6	2.6	2.0	2.9	2.1
Primary Aluminium	8.9	0.2	7.6	0.4	6.5	0.5	5.4	0.6

The revised criticality methodology affects both the economic importance (EI) and supply risk (SR) calculations; therefore the calculated indicators of EI and SR are not directly comparable with results of the 2011 and 2014 assessments. For example, the decrease of economic importance of bauxite between 2014 and 2017 is an interpretation biased by the change in methodology.

For bauxite, the supply risk indicator is marginally higher (SR=2.06, rounded to 2.1) in comparison to the 2017 assessment (SR=2.04, rounded to 2.0). For primary aluminium, the SR result is slightly higher (SR=0.59, rounded to 0.6) compared to the 2017 assessment (SR=0.49, rounded to 0.5), reflecting the rising trend in the concentration of global supply.

The calculation of economic importance is based on the use of the NACE 2-digit sectors and the value-added for the identified sectors (see Table 2 and Table 3). The figures used for the value-added were the averages of the period 2012-2016, corresponding to 27 Member States (i.e. excluding UK).

For bauxite, the same allocation of end uses and corresponding 2-digit NACE sectors was applied in the 2017 and the current assessment for the calculation of the economic importance indicator (EI). The increase in EI in comparison to the 2017 assessment can be attributed to the results scaling step<sup>28</sup>, because the value-added of the largest manufacturing sector in the current assessment is lower, as it corresponds to 27 Member States (i.e. excluding UK). In contrast, in the 2017 assessment it was related to EU28.

The calculation of economic importance for aluminium is not straightforward due to its wide-ranging end uses. Hence, for the mobility application sector, two 2-digit NACE sectors have been applied and the calculation formula adjusted to accommodate this. In reality, other 2-digit NACE sectors may include some aluminium which have not been incorporated into the assessment. The difference in the EI of aluminium compared to the previous assessment is attributed to the fact that to each of the applications 'Transport' and 'Automotive' the whole percentage of Al demand (39%) was allocated in 2017. In the current assessment, the updated share of total demand (42%) for these two applications is equally split between them (21% each). Moreover, the applications of "Consumer durables" in the current assessment is associated with the more relevant 2-digit NACE sector C25 "Manufacture of fabricated metal products, except machinery and equipment" and not with the sector C28 "Manufacture of machinery and equipment not elsewhere specified".

### **3.7 Data sources**

---

The source of bauxite and primary aluminium production data was 'World Mining Data' published by the Austrian Federal Ministry for Sustainability and Tourism and the International Organising Committee for the World Mining Congress. Trade data were extracted from Eurostat's Comext database. The dataset developed by the EU MSA study of aluminium was the source for the EoL-RIR. Data on trade agreements are taken from the DG Trade webpages, which include information on trade agreements between the EU and other countries. Information on export restrictions is derived from the OECD database on export restrictions on Industrial Raw Materials. The European Aluminium Association was the source of end-uses for aluminium products in Europe, and the Aluminium/Bauxite factsheet of the 2017 assessment the source for bauxite end-uses.

---

<sup>28</sup> The results are scaled by dividing the calculated EI score by the value of the largest manufacturing sector NACE Rev. 2 at the 2-digit level and multiplied by 10, in order to reach the value in the scale between 0-10.



### 3.7.1 Data sources used in the factsheet

Aluminium Association (2019) Aluminum 101, Aluminium 101. Available at: <https://www.aluminum.org/aluminum-advantage/aluminum-101> (Accessed: 31 July 2019).

ASI (2019) ASI Home - Aluminium Stewardship Initiative, The Aluminium Stewardship Initiative. Available at: <https://aluminium-stewardship.org/> (Accessed: 6 August 2019).

Balomenos, E. (2019) 'Bauxite Residue as a resource in Europe', in Blengini, G. A. et al. (eds) Recovery of critical and other raw materials from mining waste and landfills: State of play on existing practices. European Commission. Joint Research Centre. doi: 10.2760/494020.

Bertram, M. et al. (2017) 'A regionally-linked, dynamic material flow modelling tool for rolled, extruded and cast aluminium products', Resources, Conservation and Recycling, 125(June), pp. 48–69. doi: 10.1016/j.resconrec.2017.05.014.

BGS (2019) World mineral statistics data, British Geological Survey. Available at: <https://www.bgs.ac.uk/mineralsuk/statistics/wms.cfc?method=searchWMS>.

Buchholz P., Wellmer F.W., Bastian D., Liedtke M. (2019) Leaning against the wind: Low price benchmarks for acting anticyclically in the metal markets. Mineral Economics. <https://doi.org/10.1007/s13563-019-00199-y>

CME Group (2019) Alumina Futures Overview. Available at: <https://www.cmegroup.com/education/brochures-and-handbooks/alumina-futures-overview.html> (Accessed: 21 September 2019).

CORDIS (2019) Towards sustainable mineral and metal industry: ZERO Bauxite Residue and ZERO CO2 from co-production of Alumina, Silica and precipitated Calcium carbonate by the Aranda-Mastin technology | AISiCal Project | H2020-EC | CORDIS | European Commission, AISiCal. Available at: <https://cordis.europa.eu/project/rcn/223243/factsheet/en> (Accessed: 20 September 2019).

DERA (2018) 'Chart des Monats, April 2018. Schlagabtausch auf dem Aluminiummarkt', p. 2018. Available at: [https://www.deutsche-rohstoffagentur.de/DERA/DE/Publikationen/Chart\\_des\\_Monats/cdm\\_node.html](https://www.deutsche-rohstoffagentur.de/DERA/DE/Publikationen/Chart_des_Monats/cdm_node.html).

Dessart, F. J. and Bontoux, L. (2017) Non-ferrous Metals Manufacturing: Vision for 2050 and Actions Needed, JRC Science for Policy Report. doi: 10.2760/70022.

Djukanovic, G. (2016) Steel cannot compete with aluminium in vehicle lightweighting – Aluminium Insider, Aluminium Insider. Available at: <https://aluminiuminsider.com/steel-cannot-compete-with-aluminium-in-vehicle-lightweighting/> (Accessed: 4 August 2019).

EC (2018a) Commission implementing Regulation (EU) No 2018/640 of 25 April 2018 introducing prior Union surveillance of imports of certain aluminium products originating in certain third countries, Official Journal of the European Union. Available at: [https://eur-lex.europa.eu/legal-content/EN/TXT/?uri=uriserv%3AOJ.L\\_.2018.106.01.0007.01.ENG](https://eur-lex.europa.eu/legal-content/EN/TXT/?uri=uriserv%3AOJ.L_.2018.106.01.0007.01.ENG) (Accessed: 7 August 2019).

EC (2018b) Regulation (EU) 2018/640 of 25 April 2018 introducing prior Union surveillance of imports of certain aluminium products originating in certain third countries. European Commission.

Eurostat Comext (2019) Easy Comext database. Available at: <http://epp.eurostat.ec.europa.eu/newxtweb/>.

Eurostat Prodcum (2019) Statistics on the production of manufactured goods (PRODCOM NACE Rev.2), Prodcum - Statistics by Product. Available at: <https://ec.europa.eu/eurostat/web/prodcum> (Accessed: 14 July 2019).

Eurometaux (2015) 'Our Metals Future. The metals industry's 2050 vision for a Sustainable Europe.'

Euromines (2019) 'The raw materials contribution to the implementation of the EU Sustainable Finance Action Plan'. Available at: <http://www.euromines.org/news/euromines-position-on-the-eu-sustainable-finance-action-plan>.

European Aluminium (2014) 'Aluminium Packaging: convenient, safe and infinitely recyclable'. European Aluminium Association. Available at: [https://european-aluminium.eu/media/1346/packaging-brochure\\_en.pdf](https://european-aluminium.eu/media/1346/packaging-brochure_en.pdf).

European Aluminium (2016) Recycling aluminium: A pathway to a sustainable economy.

European Aluminium (2018a) Environmental Profile report\_Executive Summary. Available at: <https://www.european-aluminium.eu/resource-hub/environmental-profile-report-2018/>.

European Aluminium (2018b) Environmental Profile Report. Life-Cycle inventory data for aluminium production and transformation processes in Europ. Available at: <https://www.european-aluminium.eu/resource-hub/environmental-profile-report-2018/>.

European Aluminium (2018c) Written submission of European Aluminium in the section 232 investigation on the effect of aluminium imports on national security. Available at: <https://www.bis.doc.gov/index.php/232-aluminum-public-comments/1985-european-aluminium-alum-public-comment-pdf/file>.

European Aluminium (2019a) 'Aluminium beverage can recycling in Europe hits record 74.5% in 2017'. Available at: <https://www.european-aluminium.eu/media/2673/european-aluminium-mpe-aluminium-beverage-can-2017-recycling-rate-press-release.pdf>.

European Aluminium (2019b) EU aluminium imports dependency. Available at: <https://www.european-aluminium.eu/data/economic-data/eu-aluminium-imports-dependency/> (Accessed: 4 August 2019).

European Aluminium (2019c) European Aluminium & the Sustainable Development Goals.

European Aluminium (2019d) European Aluminium website. Available at: <https://www.european-aluminium.eu/> (Accessed: 12 July 2019).

European Aluminium (2019e) Vision 2050. A vision for strategic, low carbon and competitive aluminium. Available at: <https://www.european-aluminium.eu/resource-hub/vision-2050/>.

European Commission (2011) Critical raw materials. Available at: [https://ec.europa.eu/growth/sectors/raw-materials/specific-interest/critical\\_en](https://ec.europa.eu/growth/sectors/raw-materials/specific-interest/critical_en) (Accessed: 8 July 2019).

European Commission (2014) Report on critical raw materials for the EU - Critical raw materials profiles. Available at: <https://ec.europa.eu/docsroom/documents/11911/attachments/1/translations/en/renditions/pdf>.

European Commission (2017) Study on the review of the list of critical raw materials. Non-Critical Raw Materials Factsheets. European Commission. doi: 10.2873/876644.

European Commission (2018) In-depth analysis in support of the Commission Communication COM(2018)/773. 'A Clean Planet for all. A European strategic long-term vision for a prosperous, modern, competitive and climate neutral economy'. Available at: [https://ec.europa.eu/clima/sites/clima/files/docs/pages/com\\_2018\\_733\\_analysis\\_in\\_support\\_en\\_0.pdf](https://ec.europa.eu/clima/sites/clima/files/docs/pages/com_2018_733_analysis_in_support_en_0.pdf).

European Commission (2019) Negotiations and agreements. Available at: <http://ec.europa.eu/trade/policy/countries-and-regions/negotiations-and-agreements/> (Accessed: 7 July 2019).

European Political Strategy Centre (2018) '10 Trends. Reshaping Climate and Energy', p. 24. Available at: [https://ec.europa.eu/epsc/sites/epsc/files/epsc\\_-\\_10\\_trends\\_transforming\\_climate\\_and\\_energy.pdf](https://ec.europa.eu/epsc/sites/epsc/files/epsc_-_10_trends_transforming_climate_and_energy.pdf).

Eurostat (2019) Annual detailed enterprise statistics for industry (NACE Rev. 2, B-E). Available at: [https://ec.europa.eu/eurostat/en/web/products-datasets/-/SBS\\_NA\\_IND\\_R2](https://ec.europa.eu/eurostat/en/web/products-datasets/-/SBS_NA_IND_R2) (Accessed: 7 July 2019).

Fastmarkets MB (2019) 'New alumina contract will address volatility, Al price disconnect, LME says.pdf'. Fastmarkets MB. Available at: <https://www.metalbulletin.com/Article/3866258/BAUXITE-and-ALUMINA-CONF-New-alumina-contract-will-address-volatility-Al-price-disconnect-LME-says.html>.

Flook, R. (2015) 'Bauxite & alumina 2015 – Non-metallurgical market review'. Available at: <https://www.metalbulletin.com/events/download.ashx/document/speaker/8449/a0ID00000X0j5LMAR/Presentation>.

Graedel, T. et al. (2015a) 'On the materials basis of modern society', Proceedings of the National Academy of Sciences, 112(20). doi: 10.1073/pnas.1312752110.

Graedel, T. et al. (2015b) 'On the materials basis of modern society. Supporting information file', Proceedings of the National Academy of Sciences of the United States of America. National Academy of Sciences, pp. 6295–300. doi: 10.1073/pnas.1312752110.

Hill, V. G. and Sehnke, E. D. (2006) Industrial Minerals and Rocks, Commodities, Markets and Uses. 7th Edition. Edited by S. T. Kogel, J.E., Trivedi, N.C., Barker, J.M. and Krukowski. Colorado, USA: Society for Mining, Metallurgy, and Exploration. Available at: <https://books.google.it/books?id=zNicdkuulE4C&pg=PA260&lpg=PA260&dq=Hill+Industrial+mINERALS+and+Rocks+bauxite&source=bl&ots=NktbuVx9td&sig=ACfU3U2phDLnx5ov04Y9ghwFja9TnWzLWQ&hl=el&sa=X&ved=2ahUKewiK3rWBnLTjAhWUSxUIHVfJBHIQ6AEwAHoECAkQAQ#v=onepage&q=Hill> (Accessed: 14 July 2019).

Hill, V. and Sehnke, E. (2006) Bauxite, Industrial minerals & rocks: commodities, markets, and uses. Edited by S. T. Kogel, J.E., Trivedi, N.C., Barker, J.M. and Krukowski. Colorado, USA: Society for Mining, Metallurgy and Exploration Inc. doi: 10.5860/choice.44-1280.

Human Rights Watch (2018) 'What Do We Get Out of It?' The Human Rights Impact of Bauxite Mining in Guinea. Available at: <https://www.hrw.org/report/2018/10/04/what-do-we-get-out-it/human-rights-impact-bauxite-mining-guinea>.

Hydro (2019) About aluminium. Available at: <https://www.hydro.com/en> (Accessed: 31 July 2019).

IAI (2009) 'Global Aluminium Recycling: A Cornerstone of Sustainable Development'. International Aluminium Institute. Available at: [www.world-aluminium.org](http://www.world-aluminium.org).

- IAI (2019a) Bauxite Mining and Refining, International Aluminium Institute. World Aluminium website. Available at: <http://bauxite.world-aluminium.org/home/> (Accessed: 14 July 2019).
- IAI (2019b) Reduction, International Aluminium Institute. World Aluminium website. Available at: <http://primary.world-aluminium.org/index.php?id=286&L=0> (Accessed: 2 August 2019).
- IAI (2019c) Smelting, International Aluminium Institute. World Aluminium website. Available at: <http://primary.world-aluminium.org/home/> (Accessed: 2 August 2019).
- IAI (2019d) 'Statistics. Primary Aluminium Production'. Available at: <http://www.world-aluminium.org/statistics/#data>.
- IAI (2019e) The aluminium story, International Aluminium Institute. World Aluminium website. Available at: <http://www.thealuminiumstory.com/> (Accessed: 12 July 2019).
- IAI, Australian Aluminium Council and Brazilian Aluminium Association (2018) Sustainable Bauxite Mining Guidelines (First Edition). doi: 10.1128/mBio.00489-12.
- Jorjani, E. and Amirhosseini, M. (2007) 'Alumina Production Process from Nepheline Ore in Razgah (Iran)', Mineral Processing Technology (MPT 2007), (April), pp. 111–115.
- Kuzvart, M. (2006) 'Industrial minerals and rocks in British Columbia', pp. 552–556. Available at: [http://www.ehu.eus/sem/seminario\\_pdf/SEMINARIO\\_SEM\\_2\\_287.pdf](http://www.ehu.eus/sem/seminario_pdf/SEMINARIO_SEM_2_287.pdf).
- Light Metal Age (2019) Primary Aluminum Producers in the Year 2018. Available at: <https://www.lightmetalage.com/resources-section/primary-producers/> (Accessed: 2 August 2019).
- LME (2019) 'LME Alumina (CRU/ Fastmarkets MB ) contract specification', pp. 1–2.
- London Metal Exchange (2017) 'LME Aluminium factsheet'. Available at: <https://www.lme.com/en-GB/Metals/Non-ferrous/Aluminium#tabIndex=0>.
- Minerals4EU (2019) European Minerals Yearbook. Available at: [http://minerals4eu.brgm-rec.fr/m4eu-yearbook/theme\\_selection.html](http://minerals4eu.brgm-rec.fr/m4eu-yearbook/theme_selection.html).
- Mining Greece (2019) Bauxite. Available at: <https://www.mininggreece.com/mining-greece/minerals/bauxite/> (Accessed: 17 September 2019).
- Musfirah, A. . and Jaharah, A. . (2012) 'Magnesium and Aluminum Alloys in Automotive Industry', Journal of Applied Sciences Research, 8(9), pp. 4865–4875. Available at: <http://www.aensiweb.com/old/jasr/jasr/2012/4865-4875.pdf>.
- Nappi, C. (2013) 'The Global Aluminium Industry 40 years from 1972', World Aluminum, 1(February), pp. 1–27.
- OECD (2015) 'Aluminium factsheet', pp. 108–118. doi: 10.1787/9789264190504-10-en.
- OECD (2019a) Export Restrictions on Industrial Raw Materials. Available at: [https://qdd.oecd.org/subject.aspx?Subject=ExportRestrictions\\_IndustrialRawMaterials](https://qdd.oecd.org/subject.aspx?Subject=ExportRestrictions_IndustrialRawMaterials) (Accessed: 5 July 2019).
- OECD (2019b) Measuring distortions in international markets: the aluminium value chain, OECD Trade Policy Papers. Paris. doi: 10.1787/c82911ab-en.
- Passarini, F. et al. (2018) Material flow analysis of aluminium, copper, and iron in the EU-28. Joint Research Centre. European Commission. doi: 10.2760/1079.

Rao, S. et al. (2018) Infosys, Carbon composites are becoming competitive and cost effective. Available at: <https://www.infosys.com/engineering-services/white-papers/Documents/carbon-composites-cost-effective.pdf> (Accessed: 3 July 2019).

Rudnick, R. L. and Gao, S. (2014) Composition of the Continental Crust, Treatise on Geochemistry: Second Edition. Elsevier Ltd. doi: 10.1016/B978-0-08-095975-7.00301-6.

S&P Global Market Intelligence (2018) Commodity profile. Bauxite. Price charts, Market Intelligence Platform. Available at: <https://www.spglobal.com/marketintelligence/en/campaigns/metals-mining> (Accessed: 15 June 2018).

S&P Global Market Intelligence (2019a) Commodity profile. Aluminium, Market Intelligence Platform. Available at: <https://www.snl.com/web/client?auth=inherit#dashboard/metalsAndMining> (Accessed: 19 April 2019).

S&P Global Market Intelligence (2019b) Commodity profile. Bauxite, Market Intelligence Platform. Available at: <https://www.spglobal.com/marketintelligence/en/> (Accessed: 23 August 2019).

Smart Exploration (2019) Sites. Available at: <https://smartexploration.eu/the-project/sites/> (Accessed: 7 November 2019).

The Aluminum Association (2007) 'Rolling Aluminum : From the Mine Through the Mill', p. 135.

The Aluminum Association et al. (2018) 'Working document. Aluminium excess capacity : time to act'. Available at: [https://www.european-aluminium.eu/media/2540/roadmap\\_aluminium-excess-capacity\\_time-to-act-letter-final.pdf](https://www.european-aluminium.eu/media/2540/roadmap_aluminium-excess-capacity_time-to-act-letter-final.pdf).

Thomas, B. (2018) 'Aluminium Market Outlook', CRU Presentation In GDA Aluminium 2018 Conference. Dusseldorf, pp. 1–19.

Tsirambides, A. and Filippidis, A. (2012) 'Metallic mineral resources of Greece', Open Geosciences, 4(4), pp. 641–650. doi: 10.2478/s13533-012-0110-2.

UN Comtrade (2019) International Trade Statistics Database. Available at: <https://comtrade.un.org/> (Accessed: 8 July 2019).

UNDP (2018) 'Human Development Indices and Indicators. 2018 Statistical Update', United Nations Development Programme, 27(4), p. 123. Available at: [http://www.hdr.undp.org/sites/default/files/2018\\_human\\_development\\_statistical\\_update.pdf](http://www.hdr.undp.org/sites/default/files/2018_human_development_statistical_update.pdf)  
<http://hdr.undp.org/en/2018-update>.

USGS (2016) Bauxite and Alumina Minerals Yearbook 2015.

USGS (2018a) Bauxite and Alumina Minerals Yearbook 2016. Available at: [http://minerals.usgs.gov/minerals/pubs/commodity/soda\\_ash/myb1-2015-sodaa.pdf](http://minerals.usgs.gov/minerals/pubs/commodity/soda_ash/myb1-2015-sodaa.pdf).

USGS (2018b) Mineral Commodity Summaries 2018, Mineral Commodity Summaries. U.S Geological Survey. doi: 10.3133/70194932.

USGS (2019) Mineral Commodity Summaries 2019. U.S Geological Survey. doi: 10.1007/978-3-540-47108-0-4.

USITC (2017) Aluminum: Competitive Conditions Affecting the U.S. Industry. Available at: <https://www.usitc.gov/publications/332/pub4703.pdf>.

Vadim Smirnov (1996) Alumina Production in Russia Part I, JOM. Available at: <https://www.tms.org/pubs/journals/jom/9608/smirnov-9608.html> (Accessed: 4 May 2019).

Vassiliadou, V. (2015) 'Bauxite-Alumina-Aluminium'. Available at: <https://ec.europa.eu/growth/tools-databases/eip-raw-materials/sites/rawmaterials/files/Bauxite-alumina-aluminium Presentation .pdf>.

Wanvik, J. A. N. E. (2000) 'Norwegian anorthosites and their industrial uses , with emphasis on the massifs of the Inner Sogn-Voss area in western Norway', NGU-BULL, (436), pp. 103–112.

WMD (2019) World Mining Data 2019, Reichl, C.; Schatz, M; Zsak, G. Iron and Ferro Alloy Metals, non Ferrous Metals, Precious Metals, Industrial Minerals, Mineral Fuels. Austrian Federal Ministry of Sustainability and Tourism. [online] Available at: [www.en.bmwf.at/Energy/WorldMiningData/Seiten/default.aspx](http://www.en.bmwf.at/Energy/WorldMiningData/Seiten/default.aspx)

World Bank (2018) Aggregate Governance Indicators 1996-2017, Worldwide Governance Indicators. Available at: <http://info.worldbank.org/governance/WGI/#home> (Accessed: 7 July 2019).

World Bank (2019) Commodity Price Data (The Pink Sheet), Commodity Markets. Available at: <https://www.worldbank.org/en/research/commodity-markets> (Accessed: 2 July 2019).

### **3.7.2 Data sources used in the criticality assessment**

For Aluminium:

BGS (2019) World mineral statistics data, British Geological Survey. Available at: <https://www.bgs.ac.uk/mineralsuk/statistics/wms.cfc?method=searchWMS>.

Djukanovic, G. (2016) Steel cannot compete with aluminium in vehicle lightweighting – Aluminium Insider, Aluminium Insider. Available at: <https://aluminiuminsider.com/steel-cannot-compete-with-aluminium-in-vehicle-lightweighting/> (Accessed: 4 August 2019).

European Aluminium (2018a) Environmental Profile report\_Executive Summary. Available at: <https://www.european-aluminium.eu/resource-hub/environmental-profile-report-2018/>.

Eurostat Comext (2019) Easy Comext database. Available at: <http://epp.eurostat.ec.europa.eu/newxtweb/>.

European Commission (2019) Negotiations and agreements. Available at: <http://ec.europa.eu/trade/policy/countries-and-regions/negotiations-and-agreements/> (Accessed: 7 July 2019).

FAO (2017) Global production and trade of forest products in 2017. Available at: <http://www.fao.org/forestry/statistics/80938/en/> (Accessed: 04 April 2019)

Glass Alliance Europe (2017) Glass Alliance Europe, Statistical data, 2017. Available at: <https://www.glassallianceeurope.eu/en/statistical-data> (Accessed: 04 April 2019)

IFT (2007) Institute of Food Technologists, Food Packaging—Roles, Materials, and Environmental Issues. Available at: [http://www.ift.org/~media/Knowledge%20Center/Science%20Reports/Scientific%20Status%20Summaries/FoodPackagingEnviron\\_0407.pdf](http://www.ift.org/~media/Knowledge%20Center/Science%20Reports/Scientific%20Status%20Summaries/FoodPackagingEnviron_0407.pdf) (Accessed: 04 April 2019)

London Metal Exchange (2019) 'LME Aluminium factsheet'. Available at: <https://www.lme.com/>. (Accessed: 04 April 2019)

Musfirah A.H and Jaharah A.G (2012) Magnesium and Aluminum Alloys in Automotive Industry, *Journal of Applied Sciences Research*, 8(9): 4865-4875, 2012. Available at: <http://www.aensiweb.com/old/jasr/jasr/2012/4865-4875.pdf> (Accessed: 04 April 2019)

OECD (2019a) Export Restrictions on Industrial Raw Materials. Available at: [https://qdd.oecd.org/subject.aspx?Subject=ExportRestrictions\\_IndustrialRawMaterials](https://qdd.oecd.org/subject.aspx?Subject=ExportRestrictions_IndustrialRawMaterials) (Accessed: 5 July 2019).

Passarini, F. *et al.* (2018) *Material flow analysis of aluminium, copper, and iron in the EU-28*. Joint Research Centre. European Commission. doi: 10.2760/1079.

Productive Plastics, Inc. (2017) Metal vs. Plastic: 5 Key Comparisons. Available at: <https://www.productiveplastics.com/2017/04/13/metal-vs-plastic-5-key-comparisons/> (Accessed: 04 April 2019)

Rao, S. *et al.* (2018) Infosys, Carbon composites are becoming competitive and cost effective. Available at: <https://www.infosys.com/engineering-services/white-papers/Documents/carbon-composites-cost-effective.pdf> (Accessed: 3 July 2019).

Reliance Foundry (2017) Reliance Foundry, Cast Iron and Cast Steel Available at: <https://www.reliance-foundry.com/blog/cast-iron-vs-cast-steel#gref> (Accessed: 04 April 2019)

Siemens AG (2014) White paper, Aluminum versus Copper Conductors. Available at: <https://w3.siemens.com/powerdistribution/global/EN/tip/focus-markets/Documents/Siemens-Data-Center-Whitepaper-Aluminium-versus-Copper.pdf> (Accessed: 04 April 2019)

Statista (2017) Global plastic production from 1950 to 2017. Available at: <https://www.statista.com/statistics/282732/global-production-of-plastics-since-1950/> (Accessed: 04 April 2019)

The Wood Technology Society (2018) The Wood Technology Society, Wood Products. Available at: <https://www.iom3.org/wood-technology-society/wood-products> (Accessed: 04 April 2019)

USODE (2015) U.S. Department of Energy, Innovating Clean Energy Technologies in Advanced Manufacturing. Technology Assessments. Composite Materials. Available at: [http://www.ift.org/~media/Knowledge%20Center/Science%20Reports/Scientific%20Status%20Summaries/FoodPackagingEnviron\\_0407.pdf](http://www.ift.org/~media/Knowledge%20Center/Science%20Reports/Scientific%20Status%20Summaries/FoodPackagingEnviron_0407.pdf) (Accessed: 04 April 2019)

USGS (2019) Mineral Commodity Summaries 2019. U.S Geological Survey. doi: 10.1007/978-3-540-47108-0-4.

WMD (2019) World Mining Data 2019, Reichl, C.; Schatz, M; Zsak, G. Iron and Ferro Alloy Metals, non Ferrous Metals, Precious Metals, Industrial Minerals, Mineral Fuels. Austrian Federal Ministry of Sustainability and Tourism. [online] Available at: [www.en.bmfwf.gv.at/Energy/WorldMiningData/Seiten/default.aspx](http://www.en.bmfwf.gv.at/Energy/WorldMiningData/Seiten/default.aspx)

For Bauxite:

Eurostat Comext (2019) Easy Comext database. Available at: <http://epp.eurostat.ec.europa.eu/newxtweb/>.

European Commission (2019) Negotiations and agreements. Available at: <http://ec.europa.eu/trade/policy/countries-and-regions/negotiations-and-agreements/> (Accessed: 7 July 2019).

IAI (2019a) Bauxite Mining and Refining, International Aluminium Institute. World Aluminium website. Available at: <http://bauxite.world-aluminium.org/home/> (Accessed: 14 July 2019).

Kogel et al. (2006) Industrial Minerals and Rocks, Commodities, Markets and Uses. J.E. Kogel et al (Ed). Available at: [https://books.google.be/books/about/Industrial\\_Minerals\\_Rocks.html?id=zNicdkuulE4C&redir\\_esc=y](https://books.google.be/books/about/Industrial_Minerals_Rocks.html?id=zNicdkuulE4C&redir_esc=y) (Accessed: 05 April 2019)

Kuzvart M. (2006) Industrial Minerals and Rocks in the 21st Century. Available at: [http://www.ehu.eus/sem/seminario\\_pdf/SEMINARIO\\_SEM\\_2\\_287.pdf](http://www.ehu.eus/sem/seminario_pdf/SEMINARIO_SEM_2_287.pdf). (Accessed: 05 April 2019)

OECD (2019a) Export Restrictions on Industrial Raw Materials. Available at: [https://qdd.oecd.org/subject.aspx?Subject=ExportRestrictions\\_IndustrialRawMaterials](https://qdd.oecd.org/subject.aspx?Subject=ExportRestrictions_IndustrialRawMaterials) (Accessed: 5 July 2019).

Jorjani et al. (2007) Alumina Production Process from Nepheline Ore in Razgah (Iran), Mineral Processing Technology (MPT) 2007. E. Jorjani and M. Amirhosseini. Available at: [https://www.researchgate.net/publication/268188702\\_Alumina\\_Production\\_Process\\_from\\_Nepheline\\_Ore\\_in\\_Razgah\\_Iran\\_Alumina\\_Production\\_Process\\_from\\_Nepheline\\_Ore\\_in\\_Razgah\\_Iran](https://www.researchgate.net/publication/268188702_Alumina_Production_Process_from_Nepheline_Ore_in_Razgah_Iran_Alumina_Production_Process_from_Nepheline_Ore_in_Razgah_Iran). (Accessed: 05 April (2019)

WMD (2019) World Mining Data 2019, Reichl, C.; Schatz, M; Zsak, G. Iron and Ferro Alloy Metals, non Ferrous Metals, Precious Metals, Industrial Minerals, Mineral Fuels. Austrian Federal Ministry of Sustainability and Tourism. [online] Available at: [www.en.bmwf.gv.at/Energy/WorldMiningData/Seiten/default.aspx](http://www.en.bmwf.gv.at/Energy/WorldMiningData/Seiten/default.aspx)

### **3.8 Acknowledgments**

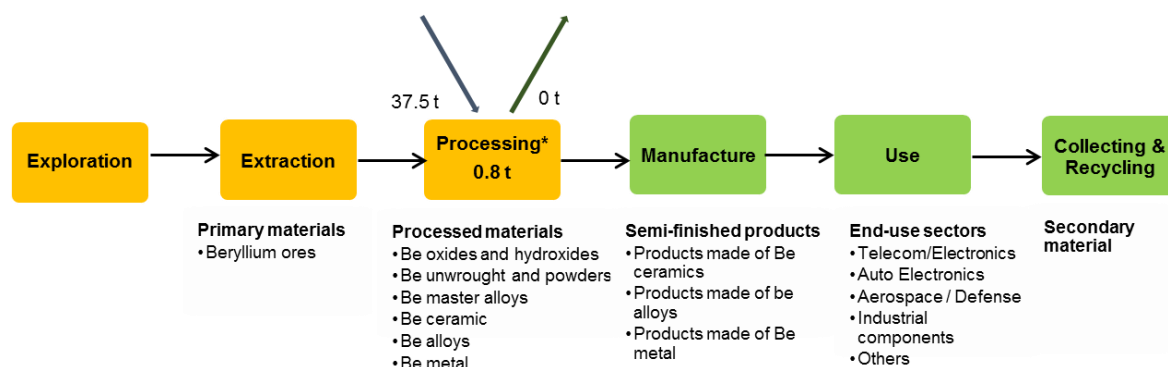
---

This factsheet was prepared by the JRC. The authors would like to thank the Ad Hoc Working Group on Critical Raw Materials, as well as experts participating in SCRREEN workshops for their contribution and feedback.



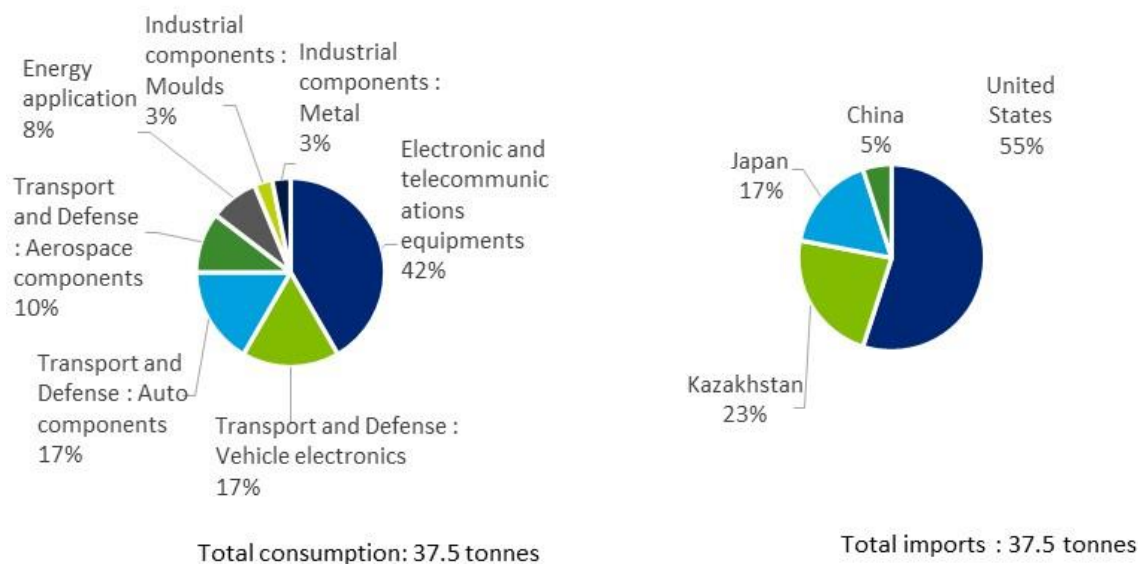
# 4 BERYLLIUM

## 4.1 Overview



**Figure 52: Simplified value chain for beryllium<sup>29</sup> for the EU, averaged over 2012-2016**

Beryllium (Be, atomic number 4, formerly also known as glucinium) is a lightweight, dark, silver-grey metal with hexagonal-close-packed structure, with high thermal stability and conductivity, flexural rigidity. Beryllium was on the EU's list of critical raw materials in 2011, 2014 and 2017. For the purpose of this assessment, beryllium was assessed at ores and concentrates and refined stage. The trade code for beryllium ores and concentrates is CN 2617900003. Two trade codes exist for refined beryllium: CN 28259020 "Beryllium oxide and hydroxide" and CN 81121200 "unwrought beryllium; beryllium powders", which however could not be used in the calculations. All quantities are provided in Be content. Approximately 80% of beryllium in commerce exists as an alloy with copper, typically containing 2% or less beryllium.



**Figure 53: EU consumption and sourcing of refined Beryllium.**

<sup>29</sup> JRC elaboration from multiple sources (see next sections). The orange boxes of the production and processing stages suggest that activities are not undertaken within the EU. \*The quantity in the Processing stage in the EU refers to criticality assessment 2017.

The annual worldwide production of beryllium in 2014 is estimated at 300 tonnes, expected to increase to more than 425 tonnes per year by 2030 (BeST, 2019b). Beryllium is not traded on any metals exchange. The price of beryllium is dependent on the form. Prices are established by direct contract negotiation between primary producers and refiners or users (European Commission, 2017). USGS publishes an estimated annual average price of beryllium content in beryllium-copper master alloys. In 2018, the price of contained beryllium in beryllium-copper master alloy was USD 500 perkg (USGS, 2019).

The average annual EU consumption of refined beryllium in 2016 was estimated at 37.5 tonnes per year (BeST, 2019a). The EU relied entirely on imports to meet its demand for refined beryllium in 2012-2016. More than half of the refined beryllium supply to the EU came from the United States.

The application of beryllium is indispensable in defence, transportation or energy applications where reliability is essential to ensure safe operation, including the construction of the ITER fusion reactor. Other uses are in electronic and telecommunications equipment and industrial components (European Commission, 2017).

World resources of beryllium are estimated at 100,000 tonnes, of which 60% are located in the United States. In the United States, proven and probable reserves were estimated at about 21,000 tonnes of beryllium content (USGS, 2019). Resources of beryllium in Europe are known to exist in Austria, Czechia, France, Finland, Germany, Italy, Portugal, Spain, Sweden, and Norway. There are no known reserves of beryllium in the EU.

The world annual production capacity of beryllium ores and concentrates in 2016 was estimated at 5,360 tonnes. The two major producers of beryllium ores were the United States (72% of global supply) and China (22% of share) (BeST, 2019a). In the EU, no beryllium is mined in 2016.

Global supply of refined beryllium in 2016 was estimated at 220 tonnes. Refined beryllium was mostly produced in the United States (50% of global supply), followed by Kazakhstan (25%), Japan (17%), and China (8%) (BeST, 2019a). Among these countries, the EU has a free-trade-agreement in place with Japan.

Beryllium is not recycled from end finished products (end-of-life recycling input rate 0%), but between 94% and 100% of new scrap is recycled (between 100 and 135 tonnes in 2013, i.e. about 20% of global demand).

Beryllium-containing dusts are toxic by inhalation causing chronic beryllium disease (CBD), also called chronic berylliosis, a chronic life-threatening lung disease. Therefore, industrial risk mitigation measures are implemented in the EU (European Commission, 2014).

## **4.2 Market analysis, trade and prices**

---

### **4.2.1 Global market analysis and outlook**

Beryllium annual consumption is expected to grow to 425 tonnes per year by 2020 and to more than 450 tonnes per year by 2030, driven by applications such as the construction of the ITER fusion reactor (BeST, 2019b). It is not possible to split the forecast by major end-market applications, due to the lack of available data. The larger increases are expected in defence and commercial applications such as (non-medical and industrial) X-ray products, semiconductor processing equipment and new types of beryllium alloys.

According to Freeman (2016), the demand for beryllium products will increase for the next 10 years, starting from 2016, as well as for the supply. Forecast on 20 years was not available

**Table 23: Qualitative forecast of supply and demand of Beryllium (Data from Freeman, 2016)**

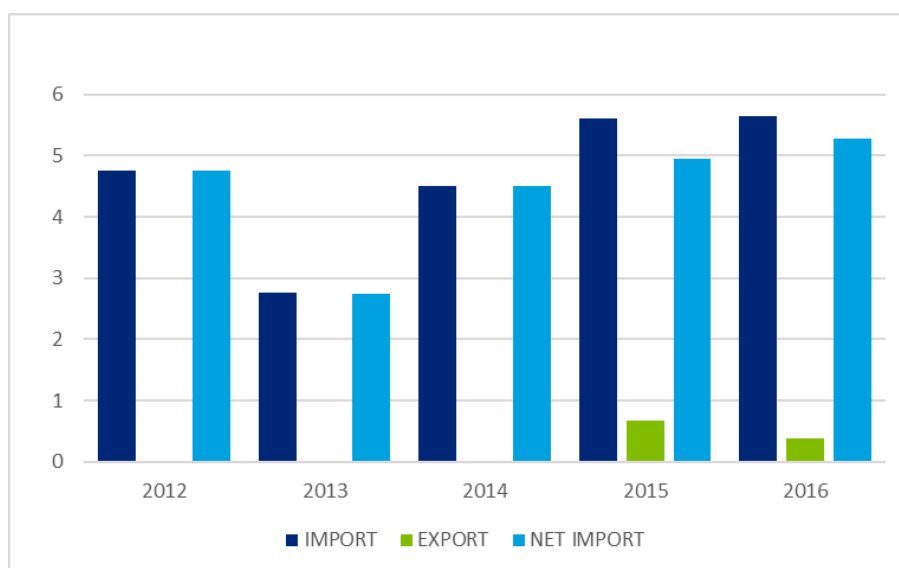
Materials	Criticality of the material in 2020		Demand forecast			Supply forecast		
	Yes	No	5 years	10 years	20 years	5 years	10 years	20 years
Beryllium	x		+	+	?	+	+	?

#### 4.2.2 EU trade

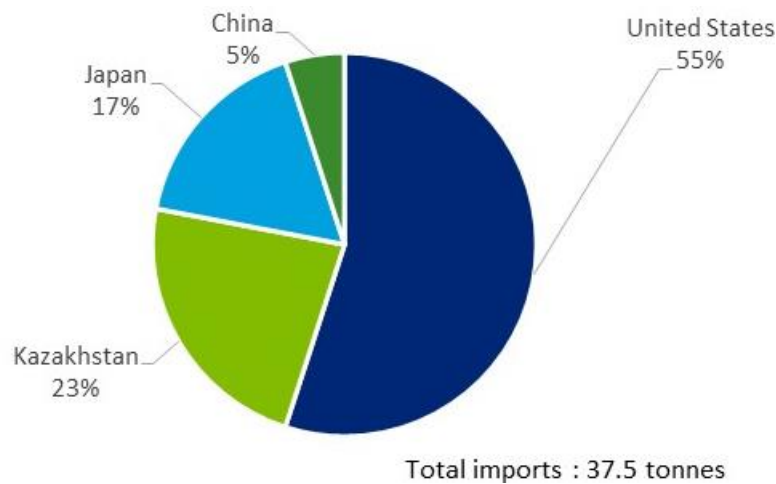
The EU does not import any beryllium ores (CN 2617900003) because there are no processing activities undertaken in the EU, also in the period considered for this assessment (2012-2016).

The EU sourced refined beryllium exclusively from import. The EU import of refined beryllium amounted to 37.5 tonnes per year on average for the period 2012-2016 (BeST, 2019a). Approximately 80% of beryllium imported into the EU are beryllium-containing alloys (mainly copper-beryllium alloys  $CuBe_2$ ) and master alloys, 15% in the form of pure metal and the remaining 5% are used in beryllium oxide ceramics. Figure 55 shows the EU imports of refined beryllium. The suppliers of the EU are the United States (55%), Kazakhstan (23%), Japan (17%), with whom the EU has a free-trade-agreement in place, and China (5%) (BeST, 2019a).

Eurostat-Comext reports trade of processed beryllium under two codes: 28259020 “beryllium oxide and hydroxide” and 81121200 “unwrought beryllium; beryllium powders”. Unfortunately these data are not sufficient to depict EU imports and exports of all refined beryllium (no codes for several types of refined beryllium, for example copper-beryllium alloys, the major part of EU import of beryllium). For this reason Comext data could not be used in the calculations. For illustration purposes only, trade flows for beryllium in Figure 54 refer to “unwrought beryllium; beryllium powders”.



**Figure 54: EU trade flows for “unwrought beryllium, beryllium powders” (CN 81121200);. Data source: Eurostat-Comext (Eurostat, 2019a)**

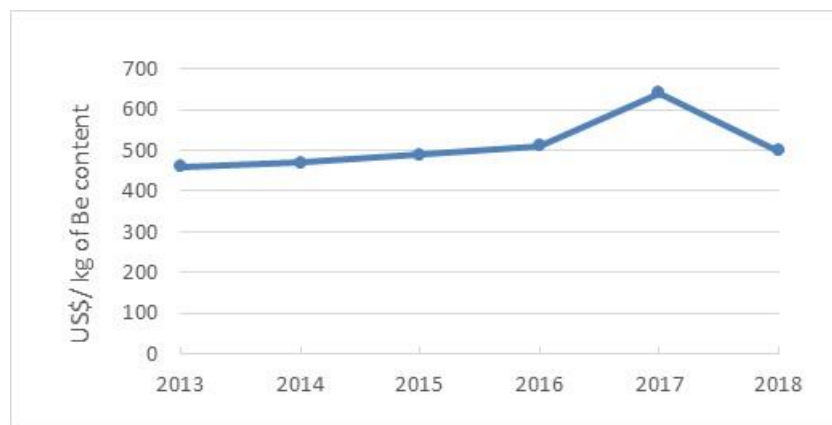


**Figure 55: EU imports of refined Be, annual average 2012-2016. Data source: (BeST, 2019a)**

There were no exports taxes, quotas or prohibition of Be products in place from countries exporting to the EU (OECD, 2019). However, according to experts, in the defence sector, there was a need of export licenses from the US or Kazakhstan (Freeman, 2016). On the contrary, the United States were not allowed to export Beryllium to China (BeST, 2019a).

#### 4.2.3 Prices and price volatility

Since beryllium is not traded on any metals exchange, there is no quotation on stock market. Prices are established by direct contract negotiation between primary producers and refiners or users (BRGM, 2016). There is no publication of beryllium prices neither on Metal Pages nor Metal Bulletin. The USGS publishes an annual average estimated price of beryllium-copper master alloy as presented in Figure 56.



**Figure 56: Price trend of beryllium contained in beryllium-copper alloy USD perkg. Data source: USGS (USGS, 2019)**

According to experts, the price of beryllium is dependent on its form (BeST, 2016b). The following prices refer to the prices of the specific beryllium containing products.

- As a fully machined aerospace component of pure beryllium: €300 – 1,500/kg
- As a cast aluminium 39% beryllium alloy aerospace component: €200 – €500/kg
- As a copper 2% beryllium alloy: €20 – 50 /kg
- As a copper 0.3% beryllium alloy in strip form: €12 – 20 /kg

## 4.3 EU demand

Annual worldwide production of refined beryllium (in alloys, metal or ceramics) in 2016 is estimated as 220 tonnes (BeST, 2019a).

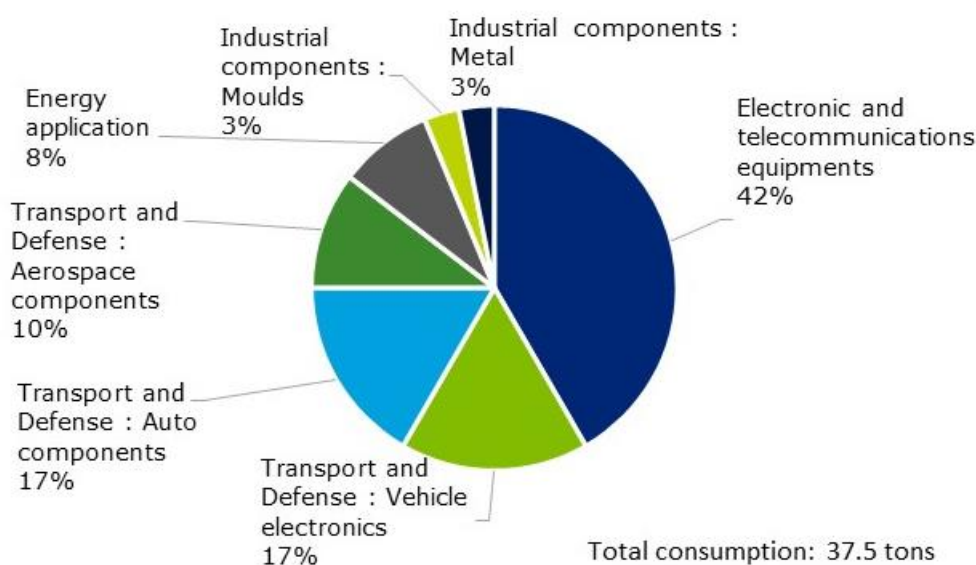
### 4.3.1 EU demand and consumption

The annual EU consumption of beryllium ores is null. In the EU, the consumption of processed beryllium materials is about 37.5 tonnes per year of beryllium content over the average 2012-2016 (BeST, 2019a). Approximately 80% of beryllium used in the EU goes into copper-beryllium alloys (containing 0.2-2% of beryllium) for the manufacture of high performance electrically conductive terminals and mechanical components. About 15% of beryllium is used in a metal matrix containing over 50% beryllium. The remaining 5% of beryllium are used in beryllium oxide ceramics for producing electrical insulation components with high thermal conductivity.

Beryllium's superior chemical, mechanical and thermal properties make it a favourable material for high technology equipment (e.g. in aerospace) for which low weight and high rigidity are important qualities. A large share of the world pure beryllium production is used for military purposes. Due to the high price and unique properties, only small amounts of pure beryllium are used in the civilian sector (European Commission, 2014; Freeman, 2016).

### 4.3.2 Uses and end-uses of Be in the EU

Figure 57 presents the main uses of beryllium in the EU over the year 2012-2016.



**Figure 57: EU end uses of Beryllium. (SCREEN, 2019; BeST, 2019;**

The end-uses of beryllium products in the EU are the following (CRM Experts, 2019):

- Electronics and telecommunication equipment: Beryllium is used as an alloying element in copper to improve its mechanical properties without impairing the electric conductivity. Copper beryllium is used in electronic and electrical connectors, battery, undersea fibre optic cables, chips (consumer electronics + telecommunications infrastructure)
- Transport and Defence:
  - Automotive electronics: connectors in vehicle components (Copper-Beryllium - CuBe) for air-bag crash sensor and deployment systems,

airbags, anti-lock brake systems and many other life safety applications, for weather forecasting satellites, undersea earthquake tsunami detection monitors, air traffic control radar, fire sprinkler systems (Nickel-Beryllium (NiBe), power steering and electronic control systems, etc.

- Other light metal vehicle components (Be used for recycling process of magnesium containing light alloys in <10 ppm): car body panels, seat frames, car steering components and wheels, etc.
- Aerospace components: landing gears, engine for aircraft, mirrors for satellites, etc.
- Industrial components:
  - Moulds for rubber and plastics, made of CuBe alloys
  - Metals: Bar, plate, rod, tube, and customized forms
- Energy application: copper-beryllium is used to stop the leaking during the Oil spills, as well as in non-magnetic equipment, down-hole equipment and non-sparking safety equipment used to improve extraction equivalent of energy applications. Pure beryllium is used in fusion research and fission energy production.
- Others: among others, Be in medical application is used as beryllium foil for high-resolution medical radiography, including CT scanning and mammography; beryllium oxide ceramic in lasers; beryllium as components to analyse blood and in X-ray equipment, etc.

Relevant industry sectors are described using the NACE sector codes (Eurostat, 2019c) in Table 24.

**Table 24: Beryllium applications, 2-digit and associated 4-digit NACE sectors and value added per sector (Data from the Eurostat database; Eurostat, 2019c)**

<b>Applications</b>	<b>2-digit NACE sector</b>	<b>Value added of 2-digit NACE sector (M€)</b>	<b>4-digit NACE sectors</b>
Electronic and telecommunications equipment	C26 - Manufacture of computer, electronic and optical products	65,703	C2610 Manufacture of electronic components, C2630 Manufacture of communication equipment
Transport and Defence: Vehicle electronics	C26 - Manufacture of computer, electronic and optical products	65,703	C2651 Manufacture of instruments and appliances for measuring, testing and navigation, C2670 Manufacture of optical instruments and photographic equipment
Transport and Defence: Auto components	C29 - Manufacture of motor vehicles, trailers and semi-trailers	160,603	C2930 Manufacture of other parts and accessories for motor vehicles: Airbags, car body panels, seat frames, car steering components and wheels
Transport and Defence: Aerospace components	C30 - Manufacture of other transport equipment	44,304	C3030 Manufacture of air and spacecraft and related machinery: Landing gears, engine for aircraft, mirrors for satellites

<b>Applications</b>	<b>2-digit NACE sector</b>	<b>Value added of 2-digit NACE sector (M€)</b>	<b>4-digit NACE sectors</b>
Energy application	C26 - Manufacture of computer, electronic and optical products	65,703	C2651 Manufacture of instruments and appliances for measuring, testing and navigation
Industrial components: Moulds	C28 - Manufacture of machinery and equipment n.e.c.	182,589	C2823 Manufacture of machinery for metallurgy ceramic
Industrial components: Metal	C24 - Manufacture of basic metals	55,426	C2420 Other non-ferrous metal production: Bar, plate, rod, tube, and customized forms

### 4.3.3 Substitution

Substitution of beryllium always leads to a loss of performance. As beryllium is expensive, it is used only when it is absolutely needed (Freeman, 2016). For example, copper-beryllium is used when reliability is essential to ensure safe operation in the defence, transport or energy sector. Pure beryllium and aluminium-beryllium (with 62% of beryllium) are used only in applications where the unique property combinations are essential for mission capabilities. (BeST, 2016a).

No other alloys offer the same combinations of copper-beryllium alloys, aluminium-beryllium alloys or pure beryllium properties. In all cases, there is a reduction in performance.

Alternate materials for copper-beryllium alloys may include (BeST, 2016a):

- Copper nickel silicon alloys (Corson alloys)
- Copper iron alloys
- Copper titanium alloys
- Copper Nickel Tin Spinodal Alloys (Cu-Ni-Sn)
- Phosphor bronzes (Cu-Fe-P)
- High Performance Bronzes (Cu-Pb-Sn + Al / Fe / Mn)

Alternate materials for the mechanical properties provided by beryllium metal could include (BeST, 2016a):

- Titanium alloys
- Magnesium alloys
- Aluminium alloys
- Carbon fibre composite

Alternate materials for the thermal properties provided by beryllium metal:

- Aluminium metal matrix composites with Silicon Carbide / Boron Nitride
- Carbon Reinforced Composites

The share of applications where beryllium can be substituted by these materials is less than 10%, especially for some applications in the defence, transportation and energy sector.

In parallel to substitution, reduction in the quantity of beryllium used in applications is also not feasible, since in practice beryllium is only used where absolutely necessary, for high priceconstrain. Furthermore, the most prevalent use of beryllium occurs in copper-beryllium alloys, which only contain between 0.2% – 2% of beryllium (BeST, 2019c).

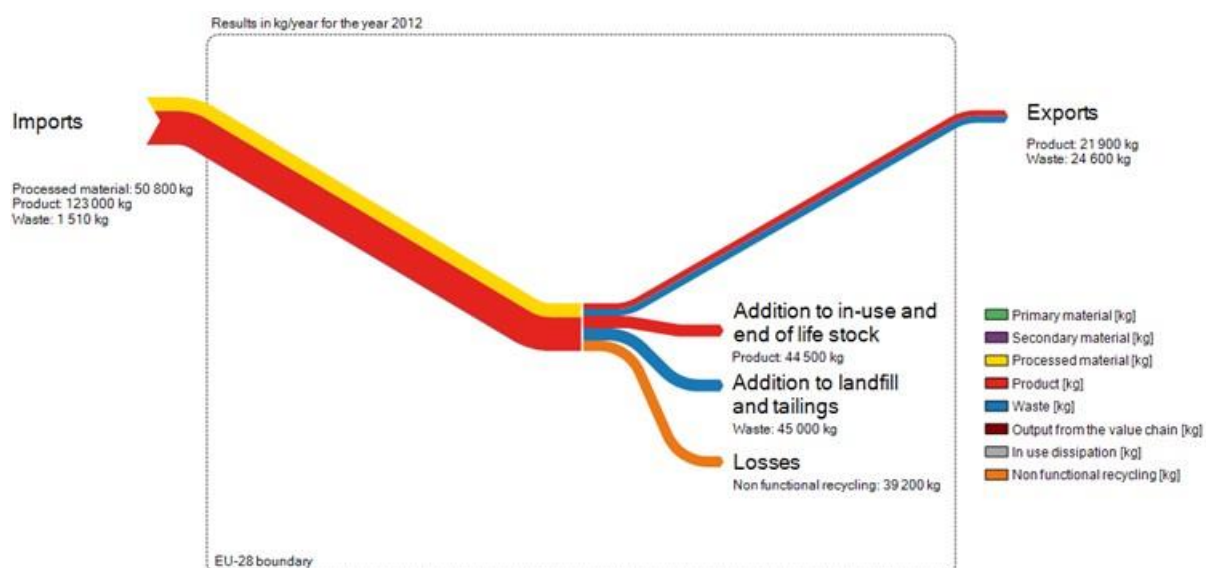
## 4.4 Supply

### 4.4.1 EU supply chain

The flows of beryllium through the EU economy are demonstrated in Figure 58.

The EU has only limited involvement in the supply chain of beryllium for the manufacturing of products made of pure beryllium and copper-beryllium (CuBe) alloys. The supply chain of beryllium in the EU is summarised as follow:

- The extraction and processing stage of beryllium takes place outside the EU. There are no known reserves of beryllium in the EU and no beryllium ores and concentrates are imported into the EU. Primary beryllium is processed into beryllium oxides and hydroxides outside the EU (Bio Intelligence Service, 2015).
- Over the years 2012-2016, the import reliance of the EU on beryllium has been estimated at 100%. The EU entirely depends on imports of processed and semi-finished products, mainly under the form of beryllium master alloys and alloys (around 30 tonnes of beryllium per year), beryllium metal (around 5.6 tonnes of beryllium per year), and beryllium oxide (around 1.9 tonnes). There is no production of alloys or metal but reprocessing (rolling, stretching, slitting, cutting) of imported strips and bars (BeST, 2019a; Bio Intelligence Service, 2015). Some beryllium ceramics are produced in the EU out of imported beryllium oxides. The European industry uses these processed materials to manufacture various finished products. Some beryllium-copper alloy strip, rod, bar and plate products are produced in France, Germany and Switzerland.
- During the manufacture step, the European industry generates a lot of scrap (around half of the beryllium input) which is generally sent back to suppliers outside Europe for recycling (Freeman, 2016). The EU also imports a large quantity of finished products containing beryllium (Bio Intelligence Service, 2015). One company in France is known to treat Beryllium-copper alloy scrap to produce new alloy (Sundqvist Ökvist et al. 2018).
- The beryllium contained in the waste ends up in landfill or is downcycled with a large magnitude material stream. However, there is no post-consumer functional recycling of beryllium in Europe and in the world (Bio Intelligence Service, 2015).



**Figure 58: Simplified MSA of beryllium flows in the EU in 2012 (BIO Intelligence Service, 2015)**



## 4.4.2 Supply from primary materials

### 4.4.2.1 Geology, resources and reserves of beryllium

**Geological occurrence:** Beryllium is a relatively rare element with a concentration of about 2.8-3 ppm in the earth's crust, and 2.1 ppm in the uppercrust (Rudnick, 2003). It is concentrated in some minerals, predominantly in beryl and bertrandite (BeST, 2016b; European Commission, 2014).

Until the late 1960s the only beryllium mineral commercially exploited was beryl ( $\text{Be}_3\text{Al}_2\text{Si}_6\text{O}_{18}$ ). Beryl contains between 3 and 5% of beryllium but the material is harder than bertrandite ( $\text{Be}_4\text{Si}_2\text{O}_7(\text{OH})_2$ ) leading to difficulties to refine into beryllium. Today the most important commercial beryllium mineral is bertrandite (over 75% of mining operations) which is extracted from ores containing 0.3-1.5% beryllium. Beryllium is also extracted from beryl as a by-product of small-scale emerald gemstone mining operations in Brazil, Argentina and other countries in South America and Africa (BeST, 2016b).

**Global resources and reserves:** World resources of beryllium are estimated at about 100,000 tonnes, of which 60% of it is located in the Spor Mountain deposit in Utah, United States. The proven and probable reserves from this deposit is estimated at 21,000 tonnes of beryllium content respectively (USGS, 2019). No information is available for the breakdown of world reserves by country.

**EU resources and reserves:** The Minerals4EU reports no data on beryllium resources and reserves in the EU (Minerals4EU, 2019).

According to experts, there are very limited resources (about 12 tonnes) of beryllium in Europe. (Bio Intelligence Service, 2015). There are known resources of beryllium in several locations in Europe, notably the Bordvedaga deposits at Rana in the north of Norway. Smaller deposits are also known to exist in Germany, Czechia and Ireland (Bio Intelligence Service, 2015). These resources are in the form of beryl crystals and are usually found in a matrix of granitic pegmatite rock.

According to a report by Lauri, L. et al. (2018), the following countries in Europe are known to have resources of beryllium, though most of them are not of economic significance:

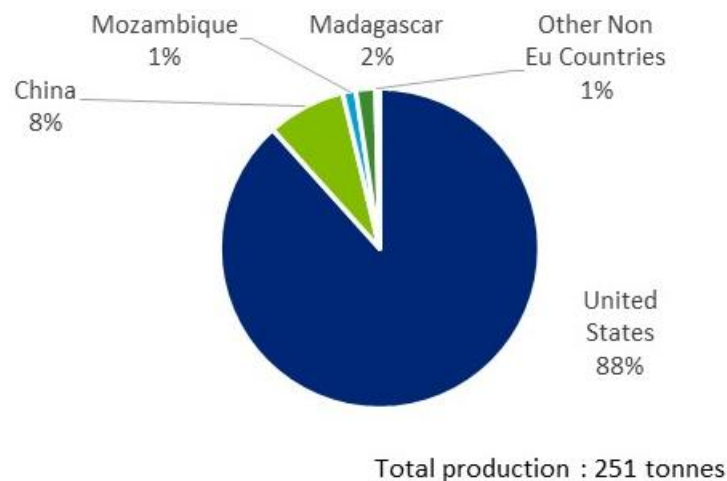
- Austria. Beryl-bearing complex pegmatites are known to be present in various locations in Austria. Only two deposits (Spittal/Wolfsberg feldspar deposit and Markogel granite quarry) are reported to have extracted in the past, but no data for beryllium is given.
- Czechia. Rare-metal pegmatites and granites containing contain beryl as an ore mineral are known to exist, but only two occurrences (Rasovna Maršíkov and Vetrny Vrch) report beryllium as the main commodity.
- Finland. Beryllium minerals are known to be present in Finland. Beryllium contents are reported from four deposits in Finland. The resource estimate available is available for the Rosendal deposit (South-West of Finland) with 206.85 tonnes of beryllium.
- France. According to BRGM (2016), there are some known resources in France in 6 deposits, including one evaluated at 2,400 tonnes of contained beryllium (BRGM, 2016). Tens of granite intrusions and granitic pegmatites with beryllium minerals are known in France, mostly located in Bretagne in (North-West of France) and in the Pyrenees (Lauri et al., 2018)
- Germany. Beryllium minerals are present in many granites and granitic pegmatites. No records available for beryllium mining (Lauri et al., 2018)

- Italy. Some occurrences of beryllium associated with granitic pegmatites are known, but they are mainly with mineralogical interest.
- Portugal. Portugal has had deposits in complex granitic pegmatites containing beryl in addition to Sn, Nb, Ta, and W minerals. Small-scale beryllium production took place in the mid-1900s from several deposits.
- Spain. Four beryllium-bearing occurrences are listed. Three of these are granitic pegmatites that contain beryl as an ore mineral. One occurrence (Galiñeiro) is associated with peralkaline gneisses and is currently of interest in terms of REE exploration.
- Sweden. One beryllium deposit and closed mine, Selvitberget, was reported but there is no resource estimate available
- In addition, the area of Högtuva in the middle of Norway, Nordland County was reported to host several spatially restricted Be beryllium deposit with phenakite as the main ore mineral (Schilling, et. al., 2015).

However, according to experts, there are no reserves of beryllium in Europe (Bio Intelligence Service, 2015).

#### 4.4.2.2 World and EU mine production

The world annual production of beryllium ores in average between 2012 and 2016 was approximately 251 tonnes of beryllium content, mainly in the United States (220 tonnes), China (20 tonnes) (Figure 59). There is no reported mining of beryllium ores in the EU (USGS, 2019).



**Figure 59: Global mine production of beryllium in tonnes and percentage. Average for the years 2012-2016. Data source: USGS (USGS, 2019)**

#### 4.4.3 Supply from secondary materials/recycling

##### 4.4.3.1 Post-consumer recycling (old scrap)

There is no known post-consumer functional recycling of beryllium in Europe and in the world. Beryllium is not recycled from end finished products (BeST, 2016b), therefore the end of life recycling input rate is 0%. The recuperation of pure metal of beryllium from end finished products is extremely difficult because of the small size of components and the tiny fraction of beryllium contained in appliances (less than 40 ppm in appliance having the highest amount of Be) (BeST, 2016b). The beryllium contained in the waste usually

ends up in landfill. The stock accumulated in landfill in the EU over the last 20 years is estimated at around 610 tonnes of beryllium content (Sundqvist Ökvist et al. 2018).

#### 4.4.3.2 Industrial recycling (new scrap)

Beryllium can be recovered from new scrap generated during the manufacture of beryllium products and from old scrap. Almost all the new scrap (between 94% and 100%) is sent back to the producer and recycled (Freeman, 2016). In 2013 secondary beryllium production from new scrap recycling was between 100 and 135 tonnes, i.e. about 20% of global demand (BRGM, 2016).

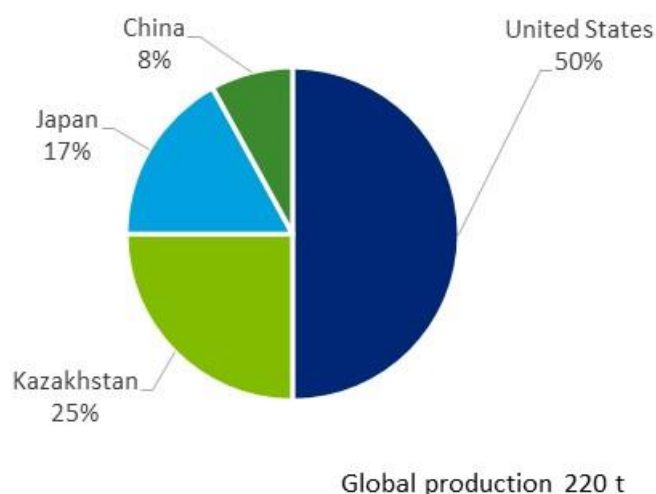
There are some companies that recycle beryllium new scrap, for example Monico Alloys and Materion (United States). In the EU, NGK Berylco (France), located near Nantes, is known to treat Beryllium-copper alloy scrap to produce new alloy. (Sundqvist Ökvist et al. 2018).

#### 4.4.4 Refining of beryllium

The extraction of beryllium from its main source's beryl and bertrandite involves several stages. After mining the ores, they are first converted to an acid-soluble form. To obtain comparatively pure beryllium hydroxide or oxide, and in a further step beryllium chloride or fluoride, complex chemical processes are used. These halogenides are then reduced to metallic beryllium with other metals or by melt electrolysis. The beryllium metal obtained is subject to one or more refining processes and finally to further treatment. The metal or other product is then incorporated into the end product, before being sent on for use (BeST, 2016b).

Annual worldwide production of refined beryllium (in alloys, metal or ceramics) in 2016 is estimated as 220 tonnes. The US production accounted for 50% (110 tonnes) of the share of global production followed by Kazakhstan (55 tonnes), Japan (37.4 tonnes) and China (17.6 tonnes), each with 25%, 17%, and 8% of share respectively. (BeST, 2019a)

The United States possesses fully integrated beryllium producer in the world, involved in the mining, ore processing, manufacture, sale and recycling of beryllium-bearing products. Japan does not extract beryllium ores but refine it from imports (Freeman, 2016) Kazakhstan refines its beryllium from stockpiled ores and will most likely to continue to do so in the future (BeST, 2019c).



**Figure 60: Global production of refined beryllium products. (BeST, 2019a), year 2016**

## 4.5 Other considerations

### 4.5.1 Environmental and health and safety issues

Because of the toxic nature of beryllium, various international, national, and State guidelines and regulations have been established regarding beryllium in air, water, and other media. Industry is required to carefully control the quantity of beryllium particles as dust, fumes, and mists in the workplace (USGS, 2019).

In the EU, beryllium is classified under the European regulation as a carcinogenic material of 1B category under the Guidance on Labelling and Packaging. It is highly toxic if inhaled in dust form during some operational steps, leading to chronic respiratory disease called chronic beryllium disease (European Commission, 2014).

Beryllium was evaluated by the German Federal Institute of Occupational Safety and Health, BAuA<sup>30</sup> under the REACH Community Rolling Action Plan (CoRAP) in 2014. The evaluation concluded that the risk associated to the exposure of beryllium is limited to the workplace. Beryllium is not on the REACH Substance of Very High Concern (SVHC) list and is not restricted under REACH or any other EU Directive in relation to its uses. In line with BauA's recommendation, beryllium was considered for regulation under the EU Carcinogen and Mutagen Directive (CMD)<sup>31</sup> and an EU wide binding occupational exposure limit was adopted. The EU adopted a binding occupational exposure limit (OEL) for Beryllium and compounds of 0.2 µg/m<sup>3</sup> – inhalable fraction 8 Hour Time Weighted Average – in the frame of the Carcinogens and Mutagens Directive. A transitional OEL of 0.6 µg/m<sup>3</sup> was adopted until 11 July 2026 in order to aid industry to comply with the new occupational exposure limit (BeST, 2019c)). In 2017, a voluntary workers protection programme was launched by industry in the sector to engage various stakeholders to improve workers safety during the production and processing of beryllium-containing materials in the EU<sup>32</sup>.

## 4.6 Comparison with previous EU assessments

The assessment has been done using the same revised methodology as used in the assessment for the CRM list 2017. The results of this and earlier assessments are shown in Table 25.

**Table 25: Economic importance and supply risk results for beryllium in the assessments of 2011, 2014 (European Commission, 2011; European Commission, 2014) and 2017**

Assessment	2011		2014		2017		2020	
	EI	SR	EI	SR	EI	SR	EI	SR
Beryllium	6.17	1.32	6.74	1.45	3.9	2.4	4.17	2.29

The economic importance of beryllium has slightly reduced compared to the value from 2017. Since the end-use sectors of beryllium remained the same as in the assessment in 2017, this decrease is the result of the change in the value added in the sectors for which beryllium is relevant.

In this criticality assessment, the supply risk of beryllium was assessed at both extraction and refining stage. The supply risk presented in Table 25 referred to the value of supply risk at extraction stage, which resulted higher than the value of the refining stage. In general, the supply risk of beryllium has lowered in comparison to the supply risk in 2017,

<sup>30</sup> Bundesanstalt für Arbeitsschutz und Arbeitsmedizin

<sup>31</sup> <https://eur-lex.europa.eu/legal-content/EN/TXT/?uri=CELEX:32019L0983>

<sup>32</sup> "Be Responsible" – [www.berylliumsafety.eu](http://www.berylliumsafety.eu)

because the global supply of beryllium ores and concentrates over the year 2012-2016 was less concentrated than in 2010-2014.

## 4.7 Data sources

---

The quantitative data for Be production at extraction stage for the 2012-2016 period was available from World mining data (in metric tonne of concentrates) and the USGS. Preference was given to the data provided by the USGS since it reported beryllium mine production in beryllium content.

Eurostat data was not usable for beryllium refined products (only beryllium oxide and powders, and no master alloys) (Eurostat, 2016a; Eurostat, 2016b). The SCRREEN experts network provided information on refined beryllium products global supply for the year 2016 and EU supply for the assessment of supply risk of beryllium at refined stage for the year 2012-2016.

### 4.7.1 Data sources used in the factsheet

BeST (2016)a. About Beryllium. [online] Available at: <http://beryllium.eu/about-beryllium/> [accessed December 2016]

BeST (2016)b. About Beryllium. [online] Available at: <http://beryllium.eu/about-beryllium/> [accessed December 2016]

BeST (2019a). Communication during the CRM workshop held in Brussels on 09/09/2019.

BeST (2019)b. Facts & Figures. [online] Available at: <http://beryllium.eu/about-beryllium/facts-and-figures/> [accessed September 2019]

BeST (2019c). Communication after AHWG meeting in Brussels on 15/10/2019.

Bio Intelligence Service (2015). Study on Data for a Raw Material System Analysis: Roadmap and Test of the Fully Operational MSA for Raw Materials – Final Report. Prepared for the European Commission, DG GROW. p41-43

European Commission (2011). Critical raw materials for the EU. [online] Available at: [https://ec.europa.eu/growth/sectors/raw-materials/specific-interest/critical\\_en](https://ec.europa.eu/growth/sectors/raw-materials/specific-interest/critical_en)

European Commission (2014) Report on critical raw materials for the EU - Critical raw materials profiles. Beryllium profile, p14-19

European Commission (2017) Report on critical raw materials for the EU - Critical raw materials profiles. Beryllium profile, p14-19

European Commission (2016). DG Trade. Agreements [online] Available at: <http://ec.europa.eu/trade/policy/countries-and-regions/agreements/>

Eurostat (2019a). International Trade Easy Comext Database [online] Available at: <http://epp.eurostat.ec.europa.eu/newxtweb/>

Eurostat (2019)c. Annual detailed enterprise statistics for industry (NACE Rev. 2, B-E). [online] Available at: [http://ec.europa.eu/eurostat/en/web/products-datasets/-/SBS\\_NA\\_IND\\_R2](http://ec.europa.eu/eurostat/en/web/products-datasets/-/SBS_NA_IND_R2)

Freeman S., Materion, BeST (2016). Communication during the CRM workshop held in Brussels on 07/11/2016.

Minerals4EU (2019). European Minerals Yearbook. [online] Available at: [http://minerals4eu.brgm-rec.fr/m4eu-yearbook/theme\\_selection.html](http://minerals4eu.brgm-rec.fr/m4eu-yearbook/theme_selection.html)

OECD (2019). Export restrictions on Industrial Raw Materials. [online] Available at: [http://qdd.oecd.org/table.aspx?Subject=ExportRestrictions\\_IndustrialRawMaterials](http://qdd.oecd.org/table.aspx?Subject=ExportRestrictions_IndustrialRawMaterials) [Accessed August 2019]

Schilling, J., Bingen, B., Skår, Ø., Wenzel, T. and Markl, G., 2015. Formation and evolution of the Høgtuva beryllium deposit, Norway. *Contributions to Mineralogy and Petrology*, 170(3), p.30.

SCREEN workshop. (2019). "Validation Workshop on Critical Raw Materials, 10-12 September 2019, Thon Hotel Brussels City Centre."

Rudnick, R.L. and Gao, S. (2003). Composition of the Continental Crust. In: *Treatise on Geochemistry, Volume 3*. Editor: Roberta L. Rudnick. Executive Editors: Heinrich D. Holland and Karl K. Turekian. pp. 659. ISBN 0-08-043751-6. Elsevier, p.1-64

USGS. (2019). Beryllium. [online] Available at: <https://minerals.usgs.gov/minerals/pubs/commodity/beryllium/mcs-2019-beryl.pdf>

World Mining Data (2019). Bundesministerium für Nachhaltigkeit und Tourismus. Austrian Federal Ministry of Sustainability and Tourism. [online] Available at: [www.en.bmwfw.gv.at/Energy/WorldMiningData/Seiten/default.aspx](http://www.en.bmwfw.gv.at/Energy/WorldMiningData/Seiten/default.aspx) Data sources used in the criticality assessment

Bio Intelligence Service (2015). Study on Data for a Raw Material System Analysis: Roadmap and Test of the Fully Operational MSA for Raw Materials – Final Report. Prepared for the European Commission, DG GROW. p41-43

Communication with Theodore Knudson, Materion, (BeST) on 04/09/2019

European Commission (2014) Report on critical raw materials for the EU - Critical raw materials profiles. Beryllium profile, p14-19

European Commission (2016). DG Trade. Agreements [online] Available at: <http://ec.europa.eu/trade/policy/countries-and-regions/agreements/>

European Commission (2017) Report on critical raw materials for the EU - Critical raw materials profiles. Beryllium profile, p14-19

Freeman S., Materion, BeST (2016). Communication during the CRM workshop held in Brussels on 07/11/2016.

Tercero Espinoza, L., Hummen, T., Brunot, A., Hovestad, A., Pena Garay, I., Velte, D., Smuk, L., Todorovic, J., van der Eijk, C. and Joce, C. 2013. "Critical Raw Materials Substitution Profiles. September 2013 Revised May 2015. CRM\_InnoNet Available At:" <http://www.criticalrawmaterials.eu/wp-content/uploads/D3.3-Raw-Materials-Profiles-final-submitted-document.pdf>.

USGS. (2012). Beryllium. [online] Available at: <http://minerals.usgs.gov/minerals/pubs/commodity/beryllium/mcs-2012-beryl.pdf>

USGS. (2013). Beryllium. [online] Available at: <http://minerals.usgs.gov/minerals/pubs/commodity/beryllium/mcs-2012-beryl.pdf>

USGS. (2014). Beryllium. [online] Available at: <http://minerals.usgs.gov/minerals/pubs/commodity/beryllium/mcs-2012-beryl.pdf>

USGS. (2015). Beryllium. [online] Available at: <http://minerals.usgs.gov/minerals/pubs/commodity/beryllium/mcs-2012-beryl.pdf>

USGS. (2016). Beryllium. [online] Available at: <http://minerals.usgs.gov/minerals/pubs/commodity/beryllium/mcs-2012-beryl.pdf>

OECD (2019). Export restrictions on Industrial Raw Materials. [online] Available at: [http://qdd.oecd.org/table.aspx?Subject=ExportRestrictions\\_IndustrialRawMaterials](http://qdd.oecd.org/table.aspx?Subject=ExportRestrictions_IndustrialRawMaterials) [Accessed August 2019]

SCRREEN workshop. (2019). Validation Workshop on Critical Raw Materials, 10-12 September 2019, Thon Hotel Brussels City Centre.

WMD (2019) World Mining Data 2019, Reichl, C.; Schatz, M; Zsak, G. Iron and Ferro Alloy Metals, non Ferrous Metals, Precious Metals, Industrial Minerals, Mineral Fuels. Austrian Federal Ministry of Sustainability and Tourism. [online] Available at: [www.en.bmwf.gv.at/Energy/WorldMiningData/Seiten/default.aspx](http://www.en.bmwf.gv.at/Energy/WorldMiningData/Seiten/default.aspx)

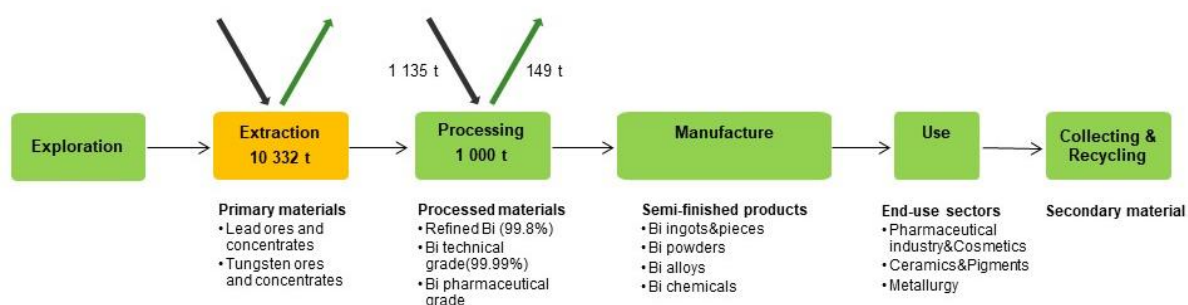
## **4.8 Acknowledgments**

---

This factsheet was prepared by the JRC. The authors would like to thank the Ad Hoc Working Group on Critical Raw Materials as well as experts participating in SCRREEN workshops for their valuable contribution and feedback, especially to Theodore Knudson, Peter Mahlmann, and Maurits Bruggink from Beryllium Science & Technology Association.

# 5 BISMUTH

## 5.1 Overview

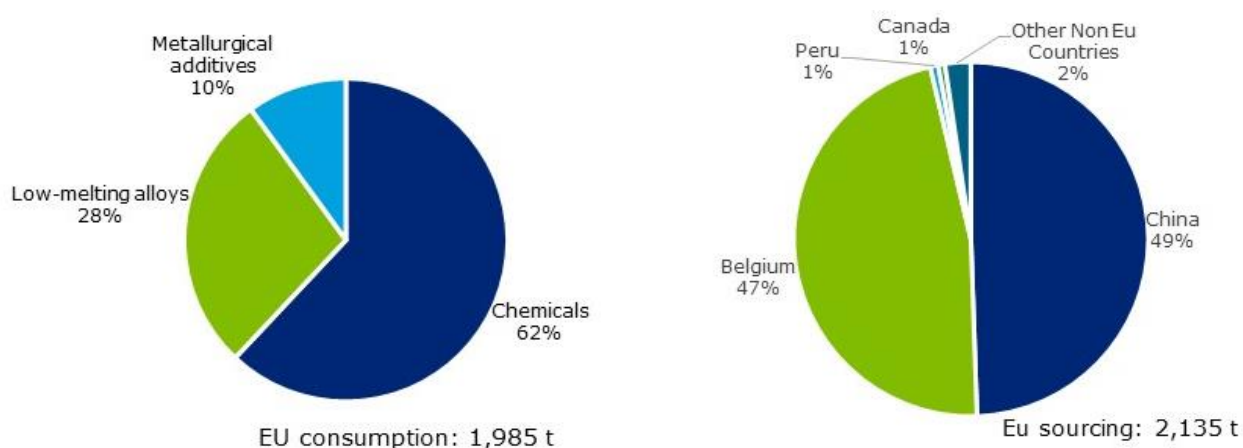


**Figure 61: Simplified value chain for Bismuth (2012-2016 average figures)<sup>33</sup>**

Bismuth (chemical symbol Bi) is a very brittle metal with a pinkish metallic lustre. It occurs naturally in the minerals bismuthinite (sulfide), bismutite (carbonate) and bismite (oxide). Very rarely extracted as main metal, it is mainly a by-product of lead and tungsten. Bismuth was on the list of CRMs in 2017 and not assessed before.

For the purpose of this assessment bismuth at processing stage is analysed. Bismuth is assessed in the form of bismuth metal (99.8% Bi contained, CN8 code CN8 81060010) Quantities expressed in tonnes of bismuth content.

The world market value of refined bismuth production is estimated to USD 6.828/t over the period Oct 2018- Sept 2019 (DERA 2019). Over the period 2012-2016 China was the top producer of mined and refined bismuth. Bismuth is not traded on any metals exchange, and there are no terminal or futures markets where buyers and sellers can fix an official price. New environmental policies that came into effect in China in 2018, resulted in many bismuth smelters shutting down temporarily for inspections or permanently for infractions (USGS 2019). Global bismuth prices decreased from USD 10.635/t in the period Jul 2017 – Jun 2018 to USD 6.828/t in Oct 2018- Sept 2019 (DERA 2019).



**Figure 62: End uses (Blazy 2013) (SCREEN Workshop 2019) and EU sourcing of Bismuth. (2012-2016 average) (DERA 2015)(USGS 2016)(Eurostat 2019b)**

The EU consumption of bismuth is 1,985 t, which is imported mainly from China and sourced through domestic production in Belgium. The EU is a net importer of refined

<sup>33</sup> JRC elaboration on multiple sources (see next sections)



bismuth. EU import reliance on refined bismuth is almost 50% (average of 2012-2016) due to the predominant share of imports from China in the EU supply for this period, which represents 93% of the total EU imports (1,135 t).

Bismuth is mainly used in the pharmaceutical and animal-feed industries (62%). Fusible alloys represent the second most important use (28%). Other uses include metallurgical additives and a number of other industrial applications such as coatings, pigments, and electronics (Ecclestone 2014) (Blazy 2013) (SCREEN workshops 2019). Substitutes exist for bismuth in many applications as in some of them it is primarily used for its non-toxicity as a replacement for already existing materials (metals).

During the Minerals4EU (2019) project, resources of bismuth were reported only in Bulgaria in the category "No statistical data available but resources known or believed to exist". Exploration projects were mentioned in Portugal and Slovakia with no further information (Minerals4EU 2019). World reserves of bismuth are estimated at around 370,000 t of contained bismuth (USGS 2017). However, these estimations have been unchanged for many years (except for Vietnam) and are likely to be incomplete since they are based on bismuth content of lead ores only, overlooking bismuth content in copper and tungsten ores.

The world annual production of refined bismuth (99.8% Bi content) (average 2012-2016) is about 19,183 t with 80% of production in China (USGS 2016). In Europe, US Geological Survey Minerals Yearbook (2016) mention mine production in Bulgaria (3.8 t, average 2012-2016), stopped in 2014.

Bismuth is difficult to recycle because it is mainly used in dissipative applications, such as pigments and pharmaceuticals. Given the type of applications, bismuth is not recyclable (MSA,2019-2020).

Several bismuth-containing substances are registered with REACH. However, none of them is on the list of substances of very high concern. Even though the REACH dossier indicates that data is lacking on the physical, health and environmental hazards of bismuth, this element is generally acknowledged for its non-toxicity in many of its uses.

## **5.2 Market analysis, trade and prices**

---

### **5.2.1 Global market analysis and outlook**

Global demand for bismuth is estimated to grow at 4-5% by year averaged over 2012-2016, thanks to high demand in pharmaceutical applications. There may also be growth in applications where there is a requirement for very low temperature solders, where bismuth is competitive. Another emerging market could come from the substantial interest in developing new classes of semiconductor, thermoelectric materials and topological insulators. It could lead to the development of emerging semiconductor compounds and alloys that contain bismuth (BIWS 2018).

On the supply side, Fortune Minerals Ltd. in Canada (London, Ontario) was granted final approval for a Type A water license for the NICO gold-cobalt-bismuth-copper mine in the Northwest Territories in 2014. The water license was one of the final steps in the permitting process, allowing construction to begin once financing had been received. Output was expected to be 41,500 troy ounces per year of gold, 1,600 metric t per year (t/yr) of cobalt, 1,700 t/y of bismuth, and 250 t/y of copper (USGS 2016) (Fortune 2019b). Fortune continues to pursue off-take agreements and financing solutions with the objective of commencing construction activities as soon as project financing is secured. Feasibility studies, test mining, pilot plants and environmental assessments have already been completed (Fortune 2019a).

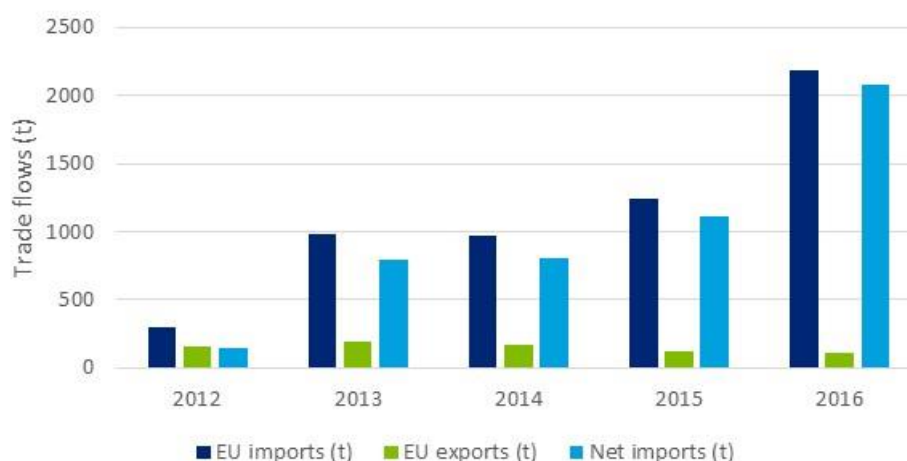
New environmental policies that came into effect in 2018 in China resulted in many bismuth smelters shutting down temporarily for inspections or permanently for infractions. However, smelters still in operation increased their output to offset the loss of production from the closures (USGS 2019).

**Table 26: Qualitative forecast of supply and demand of Bismuth**

Materials	Criticality of the material in 2020		Demand forecast			Supply forecast		
	Yes	No	5 years	10 years	20 years	5 years	10 years	20 years
Bismuth	X		+	?	?	+	?	?

### 5.2.2 EU trade

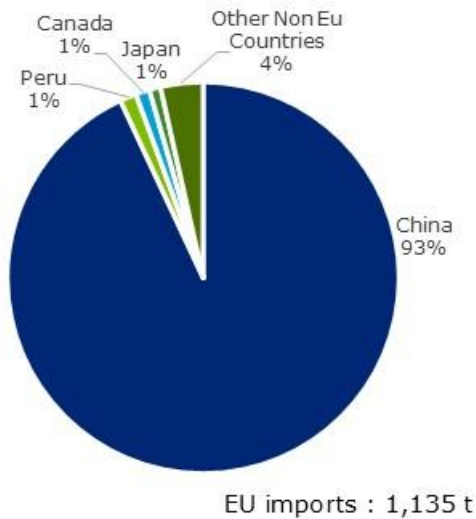
EU is a net importer of refined bismuth. With about 1,134 t per year (Bi content), import is eight times higher than export in the period 2012-2016, according to Comext (Eurostat 2019b). Export is about 150 t year. Imports for 2016 was two times higher than in 2015. Such increase could be linked with a reaction to the speculative accumulation of stocks in the Fanya Metal Exchange or to intra-company material transfer from 5N Plus subsidiary in Belgium.



**Figure 63: EU trade flows for refined Bismuth (Eurostat, 2019b)**

EU import reliance on refined bismuth is almost 50% (average of 2012-2016) due to the predominant share of China in the EU supply for this period, which represents 93% of the total EU imports.

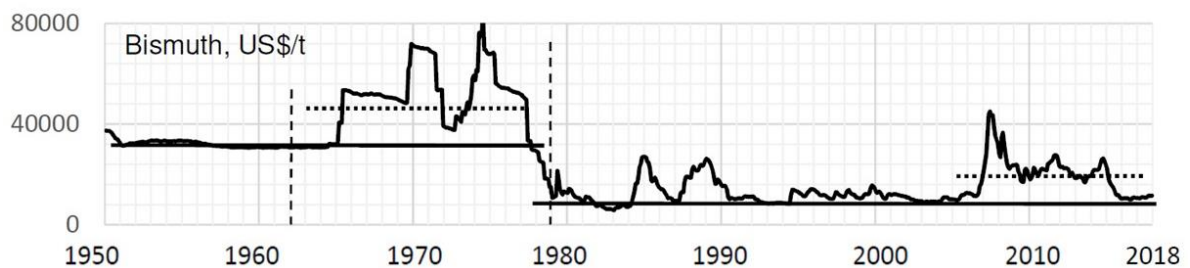
At the moment, there are no exports, quotas or prohibition in place between the EU and its suppliers (OECD 2019).



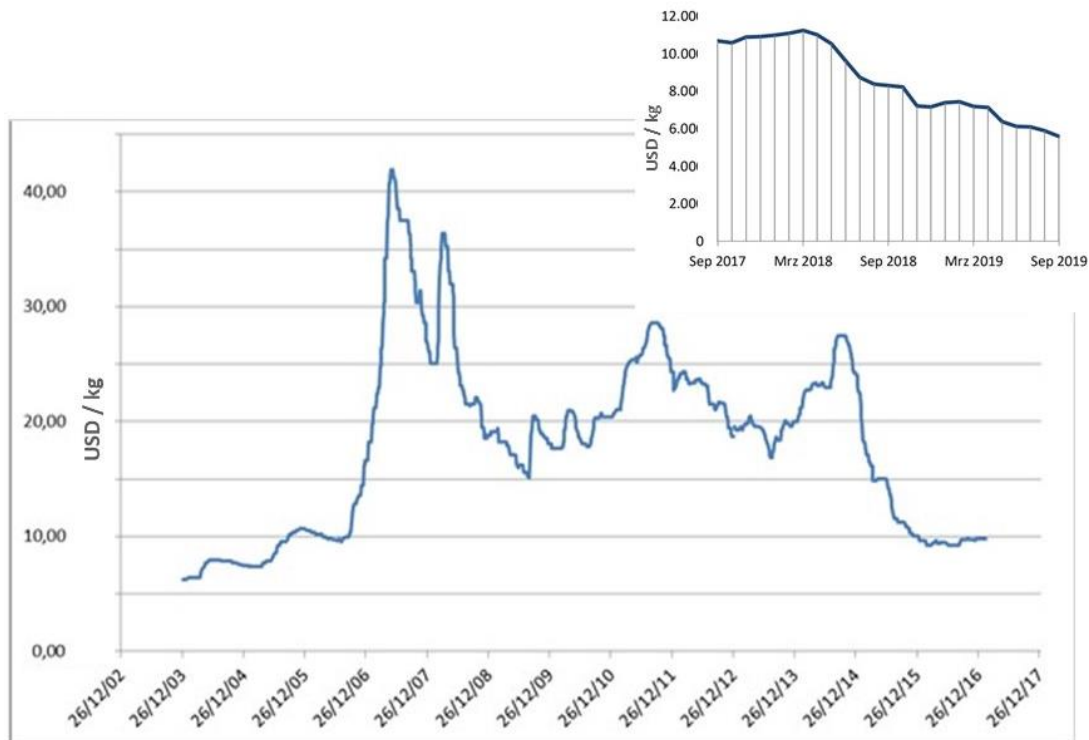
**Figure 64: EU imports (average 2012-2016) of refined Bismuth (Eurostat 2019b)**

### 5.2.3 Prices and price volatility

Bismuth is not traded on any metals exchange, and there are no terminal or futures markets where buyers and sellers can fix an official price. References for prices are obtained through averages of past deals between private parties, generally available through paid subscription (e.g. Asian Metal, Metal Pages).



**Figure 65: Bismuth long term prices. USD/t. (Buchholz et al. 2019)**



**Figure 66: Bismuth prices (99.99% Bi) in USD/kg (DERA, 2016)**

Over the past decade, the bismuth price has highly fluctuated. Prices rose dramatically in 2007 following a state-directed effort to concentrate bismuth production in China. This led to the closure of numerous smelters in the country, which accounts for 80 to 90% of global refined bismuth production. The global financial crisis brought bismuth back to prices close to 15 USD/kg in 2009. Between 2010 and 2014, speculative investment in bismuth metal by the Fanya Metal Exchange - which claimed to have bought over 18,000 t of bismuth in about a two year period - brought prices back up, until investigations into activities at the Exchange resulted in an abrupt end to these purchases and prices falling dramatically to around 10 USD/kg by 2015 and 2016 (Wilburn et al., 2016).

The trade dispute between the two largest global economies has directly resulted in the introduction of import tariffs in both China and the US, making it more expensive to trade and causing oversupply because of slower downstream consumption. The US introduced a 10% import tariff on Chinese bismuth products in September 2018 and increased it to 25% in May 2019. The import duties forced suppliers to cut their offer prices during the first half of 2019 to stimulate export demand. The bismuth price in Europe has fallen close to the cost of production; suppliers are now operating at very low margins. The price of bismuth 99.99% Bi min., in-whs Rotterdam was assessed at 5.60-6.40 USD/kg in October 2019 (Fastmarkets 2019).

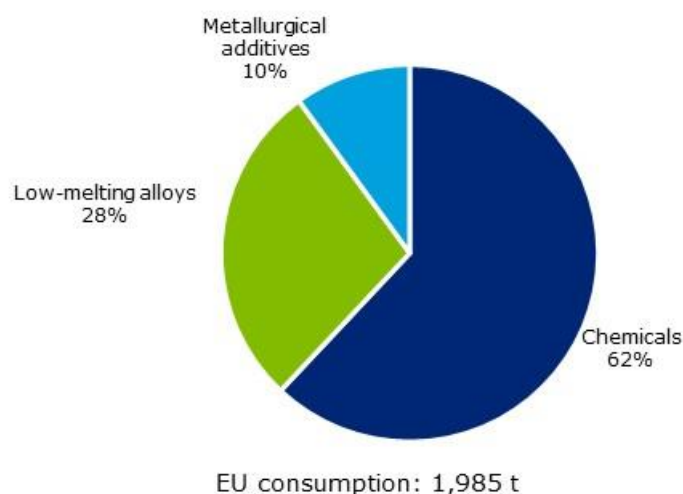
## 5.3 EU demand

### 5.3.1 EU demand and consumption

The European apparent consumption in the period 2012- 2016 (5 year average figure) is estimated at 1,985 t per year, of which 1,000 t per annum is the domestic production, in Belgium, 1,135 t per annum is the imports to the EU from extra EU countries and 150 t per annum is the exports from the EU in the same period

### 5.3.2 Uses and end-uses of Bismuth

Figure 67 presents the main uses of bismuth (average 2012-2016).



**Figure 67: End uses of bismuth. Data from (Blazy 2013) (SCREEN workshops 2019) (2012-2016 average figures)**

Bismuth is considered as an “eco-friendly” material. As a result, its first sector of application is in the pharmaceutical and animal-feed industries (62% of total uses for bismuth chemicals – see Figure 67). In modern medicine, compounds of bismuth are mainly applied clinically for gastrointestinal disorders as anti-ulcer agents. Examples are De-Nol and Pepto-Bismol used to treat and prevent gastric and duodenal ulcers. The use of bismuth (III) is also seen in nuclear medicine, anticancer, antitumor and antimicrobial studies (Yang 2007).

Fusible alloys represent the second most important use (28%). Bismuth is notably used as a replacement for more harmful metals (on top of which is lead) in solders. Other uses include metallurgical additives and a number of other industrial applications such as coatings, pigments, and electronics (Ecclestone 2014).

With an increasing focus on reducing the consumption of lead globally, bismuth alloys have found roles as efficient substitutes. Its low melting point has increased its use in electronics and its low toxicity makes it ideal for use in food processing equipment and copper water pipes. The medical industry has also found it to be a highly effective in X-ray shielding (Masan Resources 2019).

Relevant industry sectors are described using the NACE sector codes (Eurostat 2019a).

**Table 27: Bismuth applications, 2-digit and associated 4-digit NACE sectors, and value added per sector (Eurostat 2019a)**

Applications	2-digit NACE sectors	Value added of NACE 2 sectors (M€)	4-digit NACE sectors
Chemicals	C20 - Manufacture of chemicals and chemical products	105,514	C2029 - Manufacture of other chemical products n.e.c.
Fusible alloys	C32 - Other manufacturing	39,160	C3290 - Other manufacturing n.e.c.
Metallurgical alloys	C24 - Manufacture of basic metals	55,426	C2431 - Casting of iron

### 5.3.3 Substitution

Substitutes exist for bismuth in many applications as in some of them it is primarily used for its non-toxicity as a replacement for already existing materials (metals).

In pharmaceutical applications, it can be replaced by alumina, calcium carbonate, and magnesia. In pigment uses, by titanium dioxide-coated mica flakes or fish-scale extracts, and in devices such as fire sprinklers, by glycerine-filled glass bulbs. Resins can replace bismuth alloys for holding metal shapes during machining. Free-machining alloys can contain lead, selenium, or tellurium as a replacement for bismuth (USGS 2019).

## 5.4 Supply

---

### 5.4.1 EU supply chain

As a by-product, bismuth supply chain is firstly dependent on primary production of lead and tungsten. At the world level, the bismuth supply chain is in large part relying on Chinese supply of primary refined materials (purity of 99.8% Bi) still containing a lot of impurities. Those materials are massively exported to Europe, North America and South-East Asia for further refining.

Chinese control of the first steps of the bismuth market is an important aspect of this metal's criticality. China became one of the only producers of bismuth by reducing costs of production and increasing capacities in the early 2000s. In 2007, China announced the consolidation of the sector by the merging of six Hunan bismuth producers accounting for 30% of China's refined bismuth metal production in a single consortium (Hunan Bismuth Industry Co). This was done in response to the merging of the two largest players in Europe (MCP Aramayo Ltd in the UK and Sidech SA in Belgium to create MCP group, then acquired in 2011 by Canada's 5N Plus). Also, China announced the reduction of production due to environmental and mine safety issues, together with export restrictions. It succeeded in its objective to tighten supply to the rest of the world and become by far the leading producer in the following years.

In the EU, several companies are active in high added-value bismuth applications, for instance:

- 5N Plus, which controls around 50% of the bismuth market and specialty products (refined bismuth, bismuth chemicals, and low melting point alloys) and which subsidiary in Belgium is among the largest world importers of Bi (5N Plus, 2015).
- BASF, which is one of Europe's largest producers of bismuth vanadate ( $\text{BiVO}_4$ ), a key pigment for use in coatings and paints.

No trade restrictions were identified for bismuth (OECD 2019). The only stocks that are known to exist on bismuth were at the Fanya Stock Exchange.

### 5.4.2 Supply from primary materials

#### 5.4.2.1 Geology, mining and processing of bismuth

**Geological occurrence:** Bismuth mineralization can occur in various geological settings. Main occurrences are notably in tungsten, copper, gold and lead skarn deposits, as a by-product in tin pegmatites, and in magmatic-hydrothermal mineralization related to granites (Pohl 2011). As a by-product, extraction methods depend on the type and mineralogy of the ore. Bismuth has been mined as a main product only in the Cerro Tasna mine (Bolivia) and also in China (Shizhuyuan). In China, artisanal mining for bismuth also exists, with manual separation of bismuth-rich mineralization contributing significantly to global production of concentrates (Blazy 2013).

The two main sources for the recovery of bismuth metal are known to be lead and tungsten extraction and processing, with 50 to 60% coming from lead processing according to industry experts. Minor recovery of bismuth can also come from metallurgy of tin and copper, for instance in Japan, although in most cases it is seen as a penalizing impurity in those treatments (Blazy, 2013; Krenev, 2015; SCRREEN workshops 2019).

*Recovery as a by-product of lead extraction*

During the production of high purity lead from primary sources, two cases can be distinguished (Blazy 2013):

- If the bismuth content of lead bullion is higher than 4%, the electrolytic route is preferred (Betts process). Bismuth is recovered from the impure mixture of metals left in the residual anode slimes. The slime is heated, and bismuth is finally recovered after a reduction step using carbon. Concentration reaches 70-75% bismuth;
- If the bismuth content is 0.05-3.5%, the thermal route is preferred (Kroll-Betterton process). It is based on the precipitation of bismuth using calcium and magnesium which are added to molten lead. Concentration reaches 15-40% bismuth.

*Recovery as a by-product of tungsten extraction*

Not much is known concerning Chinese operations to recover bismuth from tungsten. An important part comes from artisanal mining and uses standard gravity concentration equipment including jigs and shaking tables. At the industrial scale, one example is the Xihuashan plant, where the ore is composed of scheelite, wolframite, cassiterite, bismuthinite, molybdenite, copper sulphides and REE-bearing minerals. A commercial concentrate of bismuthinite is obtained through various flotation processes and sold for further transformation (Blazy 2013). In Vietnam, first commercial production of bismuth concentrates occurred in September 2014 at the Nui Phao mine. These concentrates are also obtained through bismuth flotation, followed by leaching and cementation (Masan Resources, 2015).

**Global resources and reserves<sup>34</sup>:** For reserves, the only reference at the global level is from USGS (USGS 2017). However, these estimations have been unchanged for many years (except for Vietnam) and are likely to be incomplete since they are based on bismuth content of lead ores only, forgetting bismuth content in copper and tungsten ores.

**Table 28: Global reserves of bismuth (Data from USGS, 2017)**

Country	Reserves (t of contained Bi)
China	240 000
Vietnam	53 000

<sup>34</sup> There is no single source of comprehensive evaluations for resources and reserves that apply the same criteria to deposits of bismuth in different geographic areas of the EU or globally. The USGS collects information about the quantity and quality of mineral resources but does not directly measure reserves, and companies or governments do not directly report reserves to the USGS. Individual companies may publish regular mineral resource and reserve reports, but reporting is done using a variety of systems of reporting depending on the location of their operation, their corporate identity and stock market requirements. Translations between national reporting codes are possible by application of the CRIRSCO template.<sup>34</sup>, which is also consistent with the United Nations Framework Classification (UNFC) system. However, reserve and resource data are changing continuously as exploration and mining proceed and are thus influenced by market conditions and should be followed continuously.

Mexico	10 000
Bolivia	10 000
Canada	5 000
Other countries	50 000
<i>Total</i>	<i>368 000</i>

### **EU resources and reserves<sup>35</sup>:**

During the Minerals4EU (2019) project, resources of bismuth were reported only in Bulgaria in the category “No statistical data available but resources known or believed to exist”. Exploration projects were mentioned in Portugal and Slovakia with no further information.

#### **5.4.2.2 World and EU mine production**

Regarding mine production, China is the main producer in the world, although figures vary according to different sources (BGS, 2018; USGS, 2016; WMD 2019), partly due to the difficulty of assessing the part of artisanal production. Another important producer is Vietnam, where commercial production of bismuth concentrates started in September 2014 at the Nui Phao mine. Objectives of the company are to produce 2,000 t per year and to become the second most important producer in the world (Masan Resources 2019).

The distortion of the bismuth market due to speculative investment in the Fanya Minor Metal Exchange in China impacted the bismuth production. Fanya began trading bismuth in March 2013 and accumulated huge stocks of the metal in a 2-year period. In November 2014, bismuth stocks were reported to reach 16,900 t for about 2 years of world production equivalent (Wilburn et al., 2016). The consequences were a dramatic fall of prices and a stronger constraint on current producers.

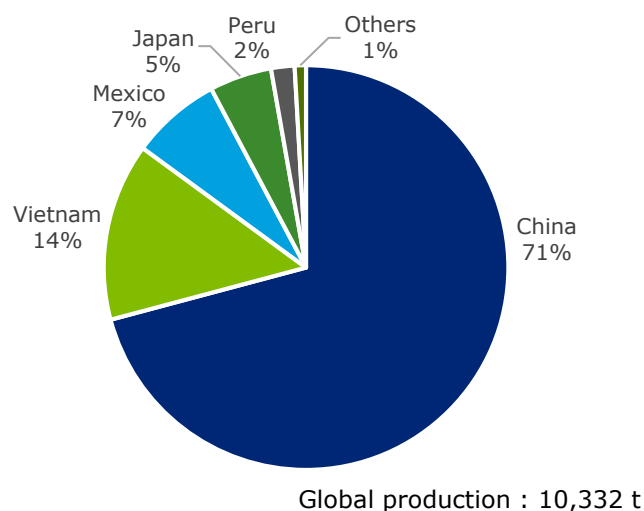
In Europe, BGS Mineral Statistics mention mine production in Bulgaria of 3 t in 2013. Bismuth is produced in Bulgaria as a Lead-Bismuth alloy (7% Bi content) by the Bulgarian smelter KCM 2000 Group (KCM 200 Group 2019). EU Production of a Lead-Bismuth alloy (6-12% Bi content) is also sited in Germany and produced by Aurubis (Aurubis 2019) (CRM experts 2019).

The world annual production of mined bismuth in average between 2012 and 2016 is around 10,332 t of bismuth content, mainly in China (WMD 2019).

---

<sup>35</sup> For Europe, there is no complete and harmonised dataset that presents total EU resource and reserve estimates for bismuth. The Minerals4EU project is the only EU-level repository of some mineral resource and reserve data for bismuth, but this information does not provide a complete picture for Europe. It includes estimates based on a variety of reporting codes used by different countries, and different types of non-comparable datasets (e.g. historic estimates, inferred reserves figures only, etc.). In addition, translations of Minerals4EU data by application of the CRIRSCO template is not always possible, meaning that not all resource and reserve data for bismuth the national/regional level is consistent with the United Nations Framework Classification (UNFC) system (Minerals4EU 2019). Many documented resources in Europe are based on historic estimates and are of little current economic interest. Data for these may not always be presentable in accordance with the UNFC system. However, a very solid estimation can be done by experts.





**Figure 68: Global mining production of bismuth (average 2012-2016) (WMD 2019)**

#### 5.4.2.3 Refining of Bismuth

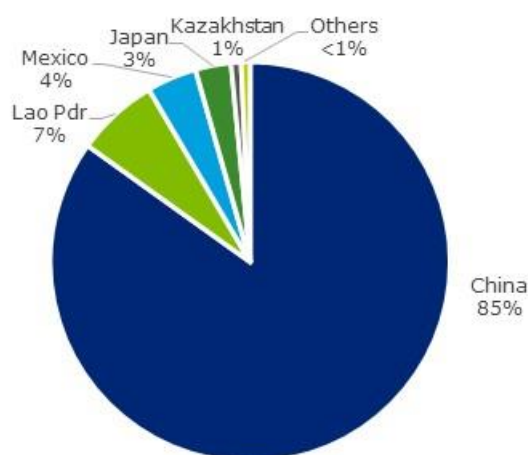
“Refined bismuth” refers to the bismuth metal of a purity of at least 99.8%, in opposition to “Bi mine production” referring to bismuth sulphide concentrates quantities. However, confusions are often made between these two categories when considering global bismuth production (BGS, 2018; WMD 2019; USGS, 2016). Furthermore, as for many other minor metals, obtaining production figures for bismuth is quite difficult because of the opaque nature of the market and its size.

The criticality assessment was performed at the refining stage because of the import reliance of the EU on refined bismuth products. There are only a few producers in the world at this stage. The main one is in China, responsible for 80% of total world production (19,183 t), the main company being Hunan Jinwang Bismuth Industrial Co Ltd ([www.en.jin-wang.com.cn](http://www.en.jin-wang.com.cn)) with capacities of 8,000 t.

In the EU, the company 5N Plus is a huge player on the bismuth market and specialty products (refined bismuth, bismuth chemicals, and low melting point alloys) and has a subsidiary in Belgium. DERA (2015) reports 1,000 t of bismuth metal produced in Belgium over 2012-2014. Belgium bismuth metal production is supplied from various EU producers mainly, i.e. Umicore in Belgium, Aurubis Cu plant in Germany, Boliden in Sweden and for some years from the Nui Phao mine in Vietnam (BGR 2019).

Refining is needed to obtain bismuth metal of a purity of at least 99.8%. Most of the time, the thermal route is preferred. During this process, caustic soda and potassium nitrate are added to the molten bismuth to remove impurities (As, Sb, Se, Te, Sn). An addition of zinc metal can be necessary when impurities include copper, silver and gold (Blazy 2013). Final treatment with soda ash can bring purity to 99.99% Bi (technical grade).

Others processes exist depending on the nature of the impurities and the required quality of final products. Electrolytic refining is preferred to obtain higher purity, up to 99.999% (pharmaceutical grade). Bismuth can be commercialised in the form of high purity ingots, pieces, pellets, or even as powdered oxide.



Global production : 18,004 t

**Figure 69: Global production capacity of refined bismuth. (USGS 2016), average 2012-2016**

### 5.4.3 Supply from secondary materials/recycling

Bismuth is not recycled (MSA, 2019-2020) (SCREEN workshops 2019). Bismuth is difficult to recycle because it is mainly used in many dissipative applications, such as pigments and pharmaceuticals (Umicore 2019).

**Table 29: Material flows relevant to the EOL-RIR of Bismuth**

MSA Flow	Value (t)
B.1.1 Production of primary material as main product in EU sent to processing in EU	0.00
B.1.2 Production of primary material as by product in EU sent to processing in EU	800.00
C.1.3 Imports to EU of primary material	3000.00
C.1.4 Imports to EU of secondary material	0.00
D.1.3 Imports to EU of processed material	1134526.00
E.1.6 Products at end of life in EU collected for treatment	0.00
F.1.1 Exports from EU of manufactured products at end-of-life	0.00
F.1.2 Imports to EU of manufactured products at end-of-life	0.00
G.1.1 Production of secondary material from post consumer functional recycling in EU sent to processing in EU	0.00
G.1.2 Production of secondary material from post consumer functional recycling in EU sent to manufacture in EU	0.00

## 5.5 Other considerations

### 5.5.1 Environmental and health and safety issues

Several bismuth-containing substances are registered with REACH. However, none of them is on the list of substances of very high concern. Even though the REACH dossier indicates that data is lacking on the physical, health and environmental hazards of bismuth, this element is generally acknowledged for its non-toxicity in many of its uses.

EU OSH requirements exist to protect workers' health and safety, employers need to identify which hazardous substances they use at the workplace, carry out a risk

assessment and introduce appropriate, proportionate and effective risk management measures to eliminate or control exposure, to consult with the workers who should receive training and, as appropriate, health surveillance<sup>36</sup>.

## 5.5.2 Socio-economic issues

No specific issues were identified during data collection and stakeholders consultation.

## 5.6 Comparison with previous EU assessments

The assessment has been conducted using the same methodology as for the 2017 list. Supply risk has been analysed at processing stage.

The results of this and earlier assessments are shown in Table 30.

**Table 30: Economic importance and supply risk results for Bismuth in the assessments of 2011, 2014, 2017, 2020 (European Commission 2011a),(European Commission 2014), (European Commission 2017)**

Assessment	2011		2014		2017		2020	
	EI	SR	EI	SR	EI	SR	EI	SR
Bismuth	Not assessed		Not assessed		3.6	3.8	4.01	2.22

Since 2017, the value-added criticality assessment corresponds to a 2-digit NACE sector rather than a 'megasector', which was used in the previous assessments.

## 5.7 Data sources

The choice of data source for production data of processed bismuth was a combination of USGS (2016) and DERA (2015) as these sources cover refined bismuth. Production data from World Mining Data may contain a mix of pure "mine producers" and "refiners". For instance, it reports figures from Japan and Vietnam, but in the first country there is no mining of bismuth and in the second, there is no refining (only bismuth concentrates are sold). Trade data were extracted from the Eurostat Easy Comext database for the Combined Nomenclature CN8 code 81011000: 'unwrought bismuth; bismuth powders; bismuth waste and scrap (excl. ash and residues containing bismuth)' (Eurostat 2019b). Data on trade agreements are taken from the DG Trade webpages, which include information on trade agreements between the EU and other countries (European Commission 2019). Information on export restrictions are derived from the OECD Export restrictions on the Industrial Raw Materials database (OECD 2019).

### 5.7.1 Data sources used in the factsheet

5N Plus (2015) Annual report - Specialty metals + chemicals. Available at: [https://www.5nplus.com/files/15/5NPlus-AR2015-EN\\_2016-06-15-16-57.pdf](https://www.5nplus.com/files/15/5NPlus-AR2015-EN_2016-06-15-16-57.pdf).

Aurubis (2019) Website [online]. Available at: <https://www.aurubis.com/products/minor-metals/lead-bismuth-alloy>.

BGR (2019) Elsner, Harald. Personal communication during the MSA study 2020 of Bismuth. Nov 2019

<sup>36</sup> <https://ec.europa.eu/social/main.jsp?catId=148>

BGS (2018) World mineral production 2012-2016. British Geological Survey, Keyworth, Nottingham. Available at: <https://www.bgs.ac.uk/mineralsUK/statistics/worldStatistics.html>.

BIWS (2018) International Workshop on Bismuth-Containing Semiconductors. Available at: <http://www.cgi.kit.ac.jp/iwbs2018.html>.

Blazy (2013) 'Métallurgie extractive du bismuth. Éditions Techniques de l'Ingénieur, doc. M 2316, pp.15'.

Buchholz P., Wellmer F.W., Bastian D., Liedtke M. (2019) Leaning against the wind: Low price benchmarks for acting anticyclically in the metal markets. Mineral Economics. <https://doi.org/10.1007/s13563-019-00199-y>

CRM experts (2019) "Feedback and comments submitted after the CRM validation workshop".

DERA (2015) Bismut - ein typisches Sondermetall.

DERA (2016) Pricelist of raw materials/ [online]. Available at: [http://www.bgr.bund.de/DE/Themen/Min\\_rohstoffe/Produkte/Preisliste/cpl\\_16\\_11.pdf?\\_\\_blob=publicationFile](http://www.bgr.bund.de/DE/Themen/Min_rohstoffe/Produkte/Preisliste/cpl_16_11.pdf?__blob=publicationFile).

DERA (2019) Preismonitor. Available at: [https://www.deutsche-rohstoffagentur.de/DERA/DE/Rohstoffinformationen/Rohstoffpreise/Preismonitor/preismonitor\\_node.html](https://www.deutsche-rohstoffagentur.de/DERA/DE/Rohstoffinformationen/Rohstoffpreise/Preismonitor/preismonitor_node.html)

Ecclestone (2014) 'The X Factor in the Chinese Dominance Challenge'. Available at: <http://investorintel.com/technology-metals-intel/bismuth-chinese-grip/>.

European Commission (2011) Critical raw materials.

European Commission (2014) Report on critical raw materials for the EU - Critical raw materials profiles.

European Commission (2017) Study on the review of the list of critical raw materials. Critical Raw Material Factsheets. European Commission. doi: 10.2873/398823.

European Commission (2019) Negotiations and agreements - Trade.

Eurostat (2019a) Annual detailed enterprise statistics for industry (NACE Rev. 2, B-E).

Eurostat (2019b) Easy Comext database.

Fastmarkets (2019) Effects of US-China trade war on bismuth mart | American Metal Market | Fastmarkets AMM. Available at: <https://www.amm.com/Article/3900776/Trade/Effects-of-US-China-trade-war-on-bismuth-mart.html> (Accessed: 22 November 2019).

Fortune (2019a) Fortune Minerals Limited - Our Assets - NICO Cobalt-Gold-Bismuth-Copper Project. Available at: <https://www.fortuneminerals.com/assets/nico/default.aspx> (Accessed: 22 November 2019).

Fortune (2019b) NICO Project Presentation. Available at: [www.sedar.com](http://www.sedar.com) (Accessed: 22 November 2019).

KCM 200 Group (2019) website [online]. Available at: <https://www.kcm2000.bg/products?page=pb>.

Krenev, V. A., Drobot, N. F. and Fomichev, S. V (2015) 'Processes for the recovery of bismuth from ores and concentrates', *Theoretical Foundations of Chemical Engineering*, 49(4), pp. 540–544. doi: 10.1134/S0040579515040132.

Masan Resources (2019) 'Annual report [online]'. Available at: <https://masangroup.com/masanresources/investor-center/annual-reports>.

Minerals4EU (2019) European Minerals Yearbook. Available at: [http://minerals4eu.brgm-rec.fr/m4eu-yearbook/theme\\_selection.html](http://minerals4eu.brgm-rec.fr/m4eu-yearbook/theme_selection.html) (Accessed: 31 July 2002).

OECD (2019) 'OECD Export restrictions on Industrial Raw Materials database'. Available at: [https://qdd.oecd.org/subject.aspx?Subject=ExportRestrictions\\_IndustrialRawMaterials](https://qdd.oecd.org/subject.aspx?Subject=ExportRestrictions_IndustrialRawMaterials).

Pohl, W. L. (2011) *Bismuth In Economic Geology, Principles and Practises, Part I Metalliferous ore deposits*, Chapter 2.5.5. Wiley&Sons.

SCREEN workshop (2019) 'Validation workshop on Critical Raw Materials, 10-12 September 2019, Thon Hotel Brussels City Centre'. Brussels.

Umicore (2019) Bismuth. Available at: <https://www.umicore.com/en/about/elements/bismuth/>.

USGS (2016) 'Klochko K. Bismuth - Mineral Yearbook'.

USGS (2017) *Mineral Commodity Summaries 2017*, U.S. Geological Survey. doi: <http://dx.doi.org/10.3133/70140094>.

USGS (2019) 'Mineral Commodity Summaries, Bismuth, February 2019'.

Wilburn, D., Bleiwas, D. and Karl, N. (2016) 'Global Stocks of Selected Mineral-Based Commodities'. Available at: <https://pubs.usgs.gov/sir/2016/5152/sir20165152.pdf>.

WMD (2019) *World Mining Data 2019*, Reichl, C.; Schatz, M; Zsak, G. Iron and Ferro Alloy Metals, non Ferrous Metals, Precious Metals, Industrial Minerals, Mineral Fuels. Austrian Federal Ministry of Sustainability and Tourism. [online] Available at: [www.en.bmwf.gv.at/Energy/WorldMiningData/Seiten/default.aspx](http://www.en.bmwf.gv.at/Energy/WorldMiningData/Seiten/default.aspx)

Yang (2007) 'Biocoordination Chemistry of Bismuth: Recent Advances, *Coordination Chemistry Review*, vol. 251, pp. 2354-2366'.

### **5.7.2 Data sources used in the criticality assessment**

BGS (2018) *World mineral production 2012-2016*. British Geological Survey, Keyworth, Nottingham. Available at: <https://www.bgs.ac.uk/mineralsUK/statistics/worldStatistics.html>.

Blazy (2013) 'Métallurgie extractive du bismuth. Éditions Techniques de l'Ingénieur, doc. M 2316, pp.15'.

BRGM (2012) L'antimoine. Available at: [http://www.mineralinfo.fr/sites/default/files/upload/documents/Plaquettes/brgm\\_plaquette\\_antimoine.pdf](http://www.mineralinfo.fr/sites/default/files/upload/documents/Plaquettes/brgm_plaquette_antimoine.pdf)

BRGM (2012) Le sélénium. Available at: [http://www.mineralinfo.fr/sites/default/files/upload/documents/Plaquettes/brgm\\_plaquette\\_selenium.pdf](http://www.mineralinfo.fr/sites/default/files/upload/documents/Plaquettes/brgm_plaquette_selenium.pdf)

BRGM (2016) Évolution des prix de divers métaux et autres substances minérales entre janvier 2003 et juillet 2016. Available at: ([http://www.mineralinfo.fr/sites/default/files/upload/documents/ecomine/Articles\\_Ecomine/courbesprixmetaux160802.pdf](http://www.mineralinfo.fr/sites/default/files/upload/documents/ecomine/Articles_Ecomine/courbesprixmetaux160802.pdf))

CRM experts (2019) "Feedback and comments submitted after the CRM validation workshop".

DERA (2015) Bismut - ein typisches Sondermetall.

European Commission (2014) *Report on critical raw materials for the EU - Critical raw materials profiles*

European Commission (2017) *Study on the review of the list of critical raw materials. Critical Raw Material Factsheets*. European Commission. doi: 10.2873/398823

European Commission (2019) *Negotiations and agreements - Trade*.

Eurostat (2019a) *Annual detailed enterprise statistics for industry (NACE Rev. 2, B-E)*.

Eurostat (2019b) *Easy Comext database*.

Fastmarkets IM (2018) TiO<sub>2</sub> prices hold steady; market reaches equilibrium. Available at: [https://www.indmin.com/Article/3826556/TiO<sub>2</sub>-prices-hold-steady-market-reaches-equilibrium.html](https://www.indmin.com/Article/3826556/TiO2-prices-hold-steady-market-reaches-equilibrium.html)

Gan A. - ICIS services (2015) ICIS services: Asia glycerine market poised to firm on tight supply. Available at: <http://www.icis.com/resources/news/2015/01/22/9854502/asia-glycerine-market-poised-to-firm-on-tight-supply>

Graedel, T.E. et al. (2015) On the materials basis of modern society - supplementary file. Available at: <https://www.ncbi.nlm.nih.gov/pmc/articles/PMC4443350/>; Proc Natl Acad Sci U S A. 2015 May 19; 112(20): 6295–6300

OECD (2019) 'OECD Export restrictions on Industrial Raw Materials database'. Available at: [https://qdd.oecd.org/subject.aspx?Subject=ExportRestrictions\\_IndustrialRawMaterials](https://qdd.oecd.org/subject.aspx?Subject=ExportRestrictions_IndustrialRawMaterials)

Nassar N.T. et al. (2015) By-product metals are technologically essential but have problematic supply. Science Advances 03 Apr 2015: Vol. 1, no. 3, e1400180 DOI: 10.1126/sciadv.1400180 Available at: (<https://advances.sciencemag.org/content/1/3/e1400180>);

Plastics Insight (2016) resin prices. Available at: <https://www.plasticsinsight.com/resin-intelligence/resin-prices/>

USGS (2016) 'Klochko K. Bismuth - Mineral Yearbook'.

USGS (2017) *Mineral Commodity Summaries 2017, U.S. Geological Survey*. doi: <http://dx.doi.org/10.3133/70140094>.

USGS (2019) 'Mineral Commodity Summaries, Bismuth, February 2019'.

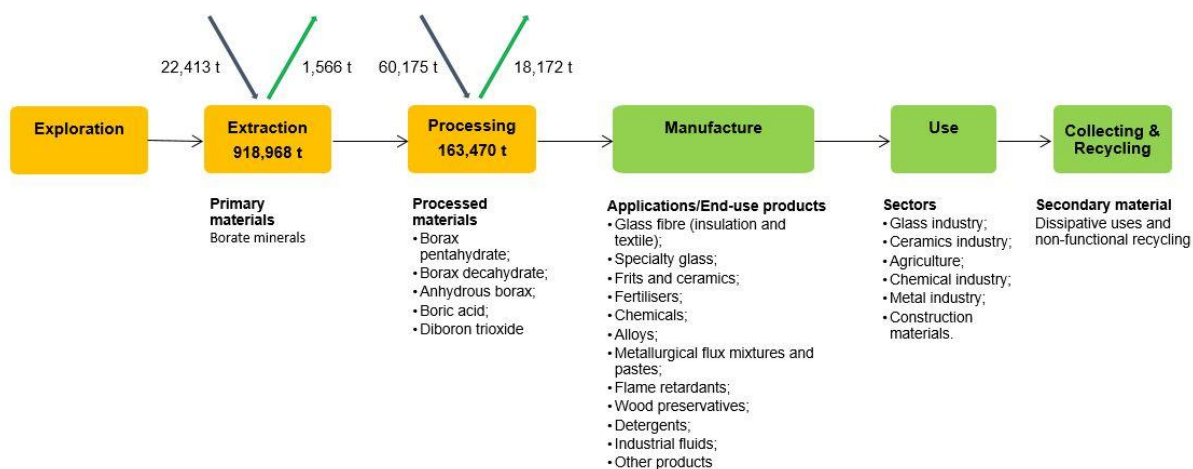
## 5.8 Acknowledgments

---

This factsheet was prepared by the JRC. The authors would like to thank the EC Ad Hoc Working Group on Critical Raw Materials and the experts participating in SCRREEN workshops for their valuable contribution and feedback.

# 6 BORATES

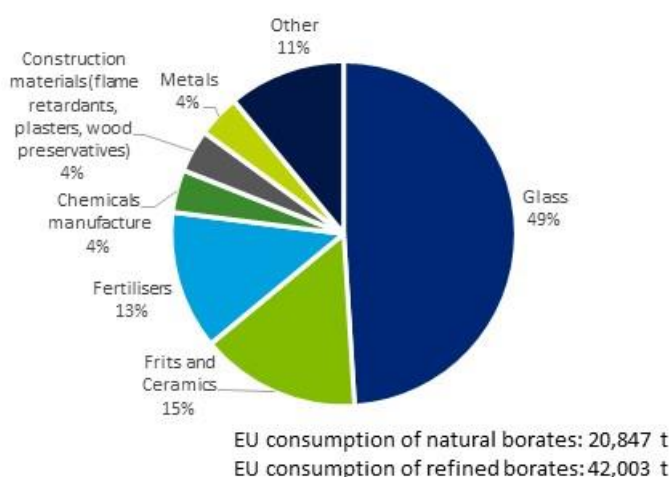
## 6.1 Overview



**Figure 70: Simplified value chain for borates for the EU, averaged over 2012-2016<sup>37</sup>**

Borates are naturally occurring minerals containing boron (B, atomic number 5). The industry defines borates as any compound that contains or supplies boric oxide ( $B_2O_3$ ). Borates are thus inorganic salts of boron and refer to a large number of mineral and chemical compounds that contain borate anions. They have metabolising, bleaching, buffering, dispersing, and vitrifying properties.

For this assessment, borates at both extraction (natural borates) and processing stage (refined borates) are analysed. At mine stage, borates are assessed in the form of natural borates and their concentrates (CN8 code 25280000, B content 20%).

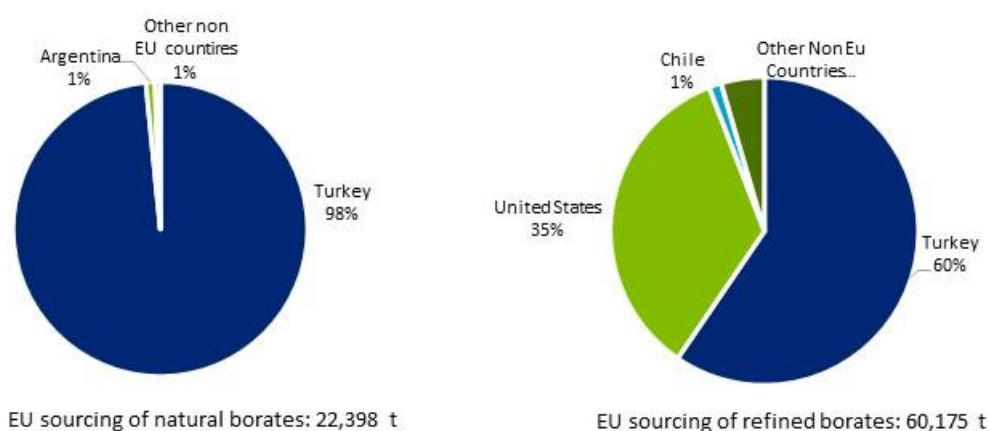


**Figure 71: End uses (IMA Europe 2016) and consumption (average 2012-2016) of borates in the EU (Eurostat Comext 2019) (WMD 2019) (UN Comtrade 2019) (WITS 2019).**

At the processing stage, the boron compounds considered are boric acid and diboron oxide, borax and anhydrous borax. The trade codes used for EU trade of refined borates are

<sup>37</sup> JRC elaboration on multiple sources (see next sections)

Diboron trioxide (CN8 28100010, B content 31%); Oxides of boron and boric acids excl. diboron trioxide (CN8 28100090, B content 17%); Anhydrous disodium tetraborate "refined borax" (CN8 28401100, B content 21%); Disodium tetraborate pentahydrate (CN 28401910, B content 15%); Disodium tetraborate decahydrate "refined borax" (CN8 28401990, B content 9%). (Eurostat Comext, 2019)



**Figure 72: EU sourcing of natural borates (left) and refined borates (right) (average 2012-2016) (Eurostat Comext 2019) (WMD 2019) (UN Comtrade 2019) (WITS 2019).**

The trade codes used are: Oxides of boron, boric acids (HS6 281000, B content 17%); Anhydrous disodium tetraborate "refined borax" (HS6 284011, B content 21%); Disodium tetraborate, not anhydrous (HS6 284019, B content: 12%). (Eurostat Comext, 2019)

All quantities are expressed in boron content, which is calculated as the boron atomic weight divided by the specific molecular weight.

The world market value of boron minerals (natural borates) production is estimated at EUR 1.25 billion. Turkey and the US dominate global exports in natural and refined borated respectively, while China is the leading importing country. The demand for borates depends on the growth of the global economy and the rise of living standards due to the nature of end uses.

After being relatively flat for many years, borate prices had a downward trend between 2005 and 2015. The average EU imports unit value for natural borates in 2018 was EUR 285 per t and for refined borates (borax pentahydrate and boric acid) EUR 360 per t of B<sub>2</sub>O<sub>3</sub> (boric oxide) content. (Eurostat Comext, 2019)

The total EU consumption of borates between 2012 and 2016 was around 62,850 t per year, comprising of 20,847 t per year natural borates (33%) and 42,003 t per year of refined borates (67%). The EU is entirely dependent on imports of borates for its consumption as there is no domestic production. The imports of natural borates to the EU come almost entirely from Turkey (98%). Turkey (60%) and the US (35%) are the main sources of EU imports of refined borates. Import reliance is 100% for both natural and refined borates (Eurostat Comext 2019).

Borates are essential ingredients in a variety of household and commercial products including: insulation fiberglass, textile fiberglass and heat-resistant glass; detergents, soaps and personal care products; ceramic and enamel frits and glazes, ceramic tile bodies; agricultural micronutrients; other uses including wood treatment, polymer additives and pest control products. Borates can be substituted with other materials in soaps, wood preservatives, and detergents (IMA Europe 2016) (SCRREEN workshops 2019).



The known world borate reserves are around 1,100 million t of contained boron (USGS 2019c). 75-80% of the world's boron reserves are located in Turkey (Helvacı 2017). No boron deposits are located in the EU.

The world annual production of natural borates is about 4,594,840 t of boron minerals (around 918,968 t in B content), averaged over 2012 to 2016. Turkey is the leading producer with a share of 43% of world mine production, followed by the US, which accounts for one-quarter (25%) (WMD 2019). Concerning refined borates, there is no official data on the world output. According to trade data relevant to oxides of boron and boric acids (B content 17%), anhydrous disodium tetraborate (refined borax) (B content 21%), other than anhydrous disodium tetraborate (refined borax) (B content 12%), it can be inferred that the US supplies the majority of processed borates (67%), followed by Chile (9%) (UN Comtrade 2019). There is no production of natural or refined borates in the EU.

Given the type of applications, borates are not recyclable. Glass recycling is considered non-functional for boron, and the end-of-life recycling input rate (EoL-RIR) is less than 1% (BIO Intelligence Service 2015a) (SCRREEN workshops 2019).

A role for borates in the implementation of the European Commission's long-term strategy for a climate-neutral economy by 2050, is identified in wind turbines through neodymium-iron-boron magnets and energy efficiency in buildings through insulation fibreglass.

Borate substances have been listed as substances of very high concern on the candidate list of the EU's REACH Regulation, and prioritisation has been given to some for authorisation under REACH (ECHA 2019a).

## **6.2 Market analysis, trade and prices**

---

### **6.2.1 Global market**

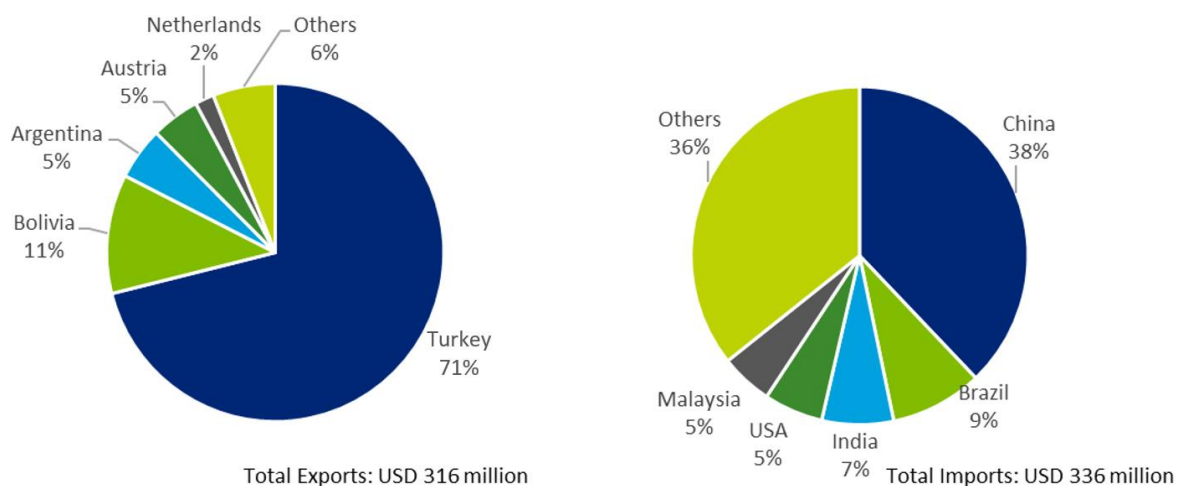
The world production of boron minerals in 2017 was about 4,594,840 t (WMD 2019) worth approximately EUR 1.25 billion<sup>38</sup>. Borates mine production declined over the past decade at an annual compound rate of -1.9%, mainly due to decreasing production from Argentina and Peru. Turkey and the US remain the largest producers.

Two companies dominate the global market by having a share of over 75%; Eti Maden which controls all borate deposits across Turkey and US Borax owned by Rio Tinto, which operates the Boron mine in California. It is reported that the market is not going to diversify any time soon as exploration is minimal by other companies (McCormick 2018). However, at current levels of consumption, world resources are adequate for the foreseeable future (USGS 2019b).

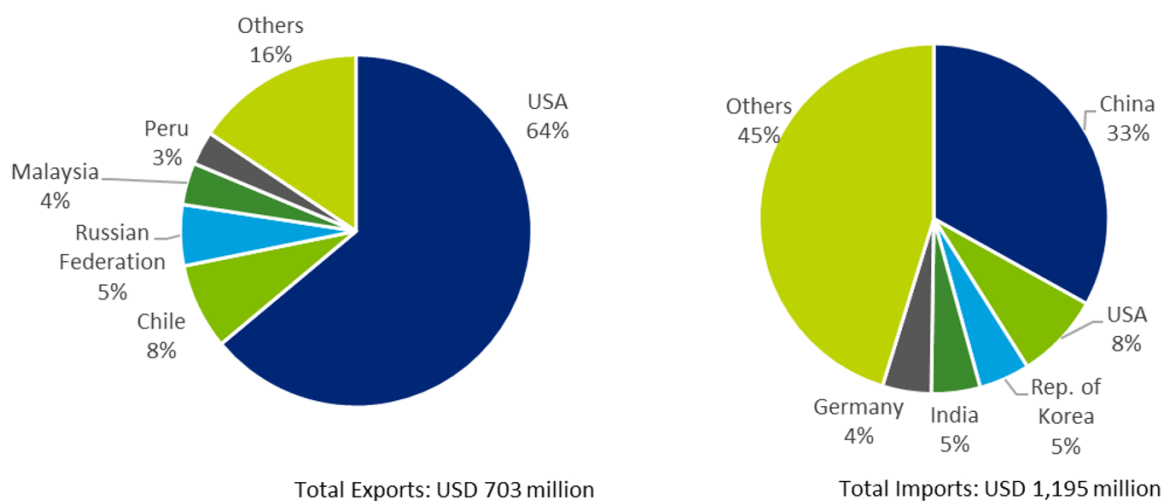
According to UN Comtrade trade data for 2016 (see Figure 73) Turkey dominates the export market of natural borates with a share of 71% of the total value, while the main importing country is China (38% of total imports by value). In terms of volume, the cross border trade (imports) of natural borates amounted to about 1 million t in 2016. For refined borates (Figure 74), the US holds the largest share of the market with 64% of the total exports, whereas China is again the leading importer (33% of total imports by value).

---

<sup>38</sup> Estimation based on the average unit value of EU imports in 2016 (EUR 290 per tonne of natural borates) and the global production in 2016.



**Figure 73: Top-5 natural borates world exporters (left) and importers (right) in 2016 by value. (UN Comtrade 2019)**



**Figure 74: Top-5 refined borates world exporters (left) and importers (right) in 2016 by value. (UN Comtrade, 2019)**

Bolivia, which accounts for about 3% of global natural borates production, applies a fiscal tax on exports of natural and refined borates of 0.05% of the gross export value. Argentina, which holds an 8% share of world natural borates production, lifted in 2016 an export tax of 10% for natural borates, and at the end of 2015 an export tax of 5% for products of refined borates (OECD 2019). However, the Government of Argentina announced the re-establishment of export duties on September 2018 on all tariff lines including codes HS 252800, HS 281000 and HS 284019 (Global Trade Alert 2018).

### 6.2.2 Outlook for supply and demand

The demand for borates tends to be associated with the growth of the global economy due to the composition of end-use markets (Rio Tinto 2014) (McCormick 2018). Demand is expected to remain relatively stable in the short term, as the strong demand growth in some market segments is partially offset by excess inventory build in the value chains of others (Rio Tinto 2015).

The medium- to long-term demand in the borates market is linked to wealth and living standards. Urbanisation, energy and food supply are the key drivers for growing demand

in the future (Rio Tinto 2014) (Rio Tinto 2018b). Consumption of borates used in fertilisers is anticipated to increase supported by the requirement for ever-greater crop yields. The rising demand for building insulation due to improvements in the building standards drives fibreglass - and thus borates - demand. Growing economies and urbanisation fuel demand for borates in glass applications, e.g. LCD televisions and electronics, which contain borosilicate glass and textile fiberglass (McCormick 2018) (Rio Tinto 2014). The rising demand for borates in the coming years is expected mostly by the agricultural, ceramic and glass sectors in Asia and South America (USGS 2018a).

In the supply side, the Jadar lithium-borate deposit in Serbia with the previously unknown mineral jadarite as the main commercial mineral was discovered by Rio Tinto in 2004. The deposit contains 21 million t of B<sub>2</sub>O<sub>3</sub> as an equivalent borate product resource. The Jadar project could potentially supply a significant proportion of global demand for borates. The pre-feasibility study is on-going for a mine and processing facility, and production could commence by 2023-2024 (Rio Tinto 2018a) (Rio Tinto 2017).

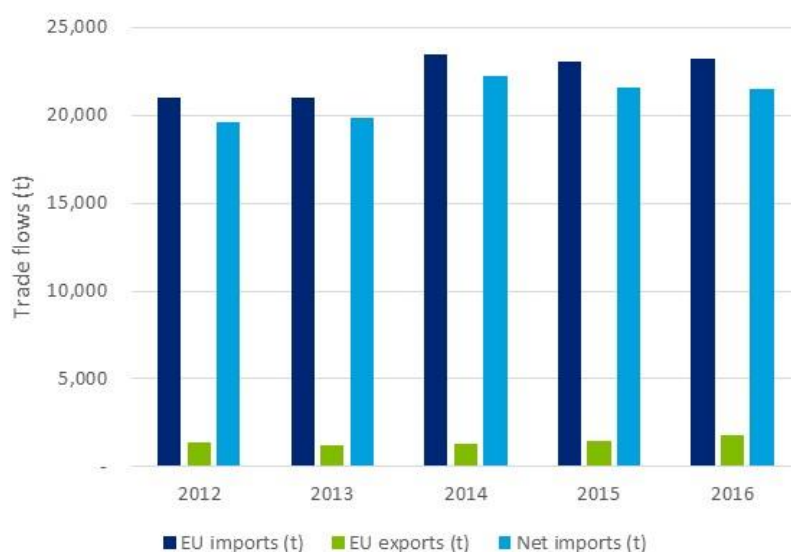
The qualitative outlook for borates supply and demand is shown in Table 31.

**Table 31: Qualitative forecast of supply and demand of borates**

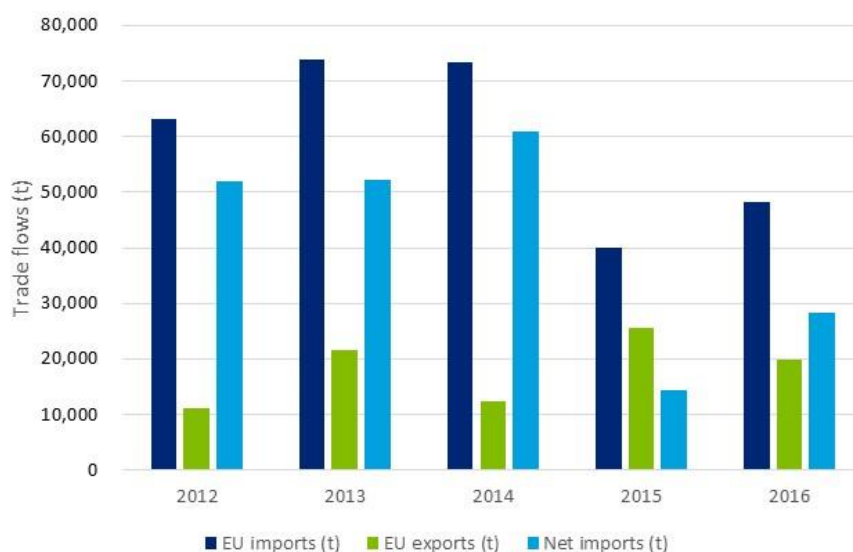
Materials	Criticality of the material in 2020		Demand forecast			Supply forecast		
	Yes	No	5 years	10 years	20 years	5 years	10 years	20 years
Borates	X		stable	+	+	stable	+	+

### 6.2.3 EU trade

The annual EU imports of natural borates were 22,410 t and the imports of refined borates 60,175 t, on average for the 2012-2016 period (in B content). The EU exports of natural and refined borates were approximately 1,565 t and 18,170 t respectively in the same period (in B content). Thus, the average net imports from 2012 to 2016 are about 20,850 t for natural borates (Figure 75), and around 42,000 t for refined borates (Figure 76) (Eurstat Comext 2019) (WITS 2019). As shown in Figure 75 and Figure 76, the main trend observed in the period 2012-2016 is the sharp decrease of net imports of refined borates in 2015 and 2016.

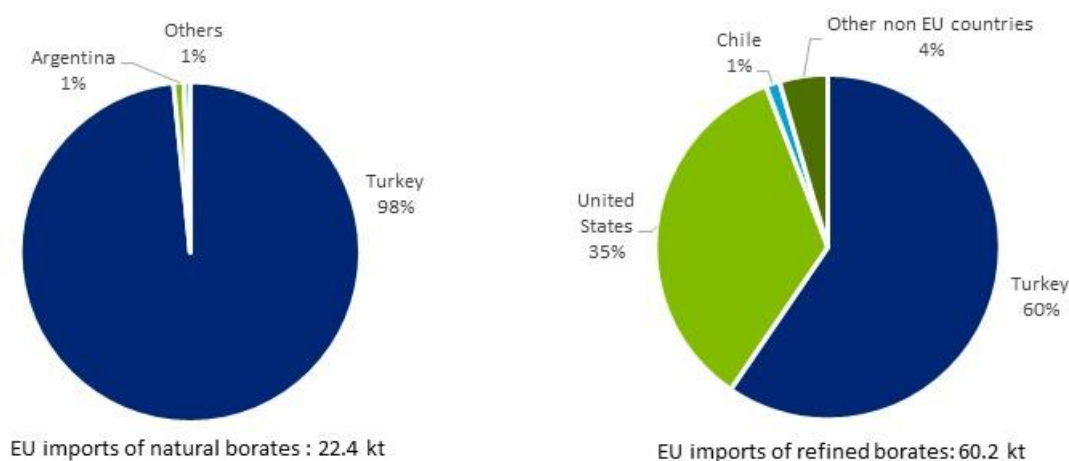


**Figure 75: EU trade flows for natural borates (in B content). (Eurostat Comext 2019)**



**Figure 76: EU trade flows for refined borates (in B content) (Eurostat Comext 2019) (WITS 2019)<sup>39</sup>**

Figure 77 shows the EU's major trading partners for imports of natural and refined borates. Turkey is almost the single supplier of the EU for natural borates, with 98% of the total imports on average over the 2012-2016 period. Likewise, Turkey is the dominant exporting country to the EU for refined borates, covering 60% of the total imports on average over the 2012-2016 period (Figure 77). The US is the second source country for EU imports of refined borates with a substantial share of 35%.



**Figure 77: EU imports of natural (left) and refined borated (right). Average 2012-2016 (in B content) (Eurostat Comext 2019) (WITS 2019)<sup>40</sup>**

<sup>39</sup> EU imports of refined borates from US and Turkey

<sup>40</sup> EU imports of refined borates from US and Turkey

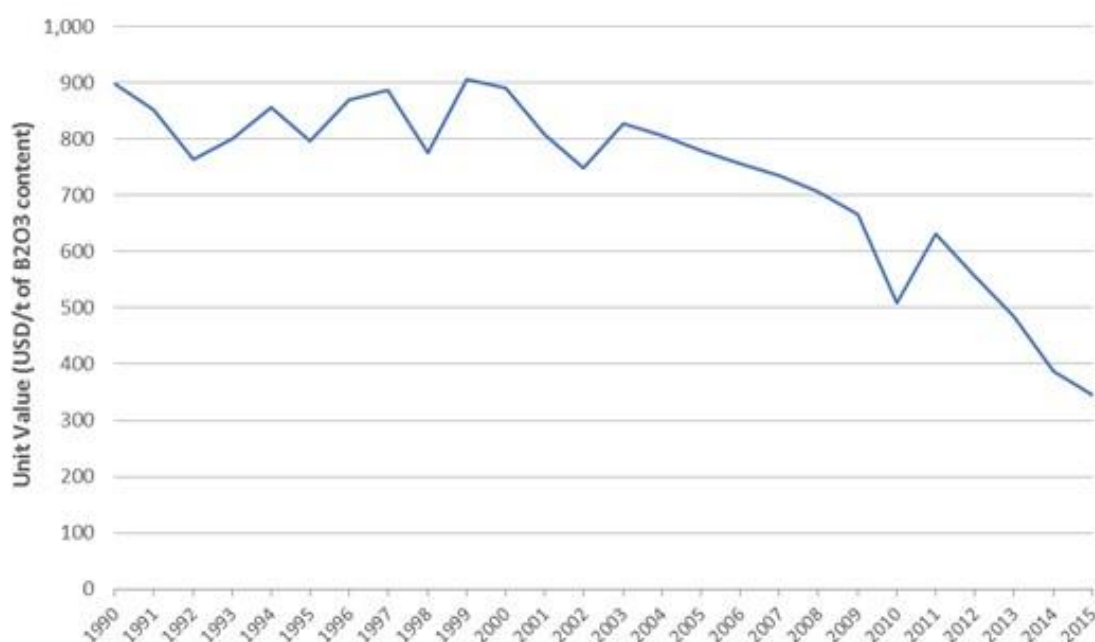
The EU and Turkey have a Customs Union agreement in force since 1996 (European Commission 2019).

#### 6.2.4 Prices and price volatility

Borates are priced and sold based on their boric oxide content ( $B_2O_3$ ), which varies by ore and boron compound and by the absence or presence of calcium and sodium (USGS, 2019a). Prices for the various refined products reflect the energy cost of refining and drying (Carpenter and Kistler 2006).

Assessments of market prices are published by the United States Geological Survey (US unit value) and price reporting agencies. In January 2019, Fastmarkets Industrial Minerals announced the discontinuation of its borates/boron minerals price assessments due to limited interest in the markets (prices referred to natural and refined borates FOB South America ports) (Fastmarkets IM 2019).

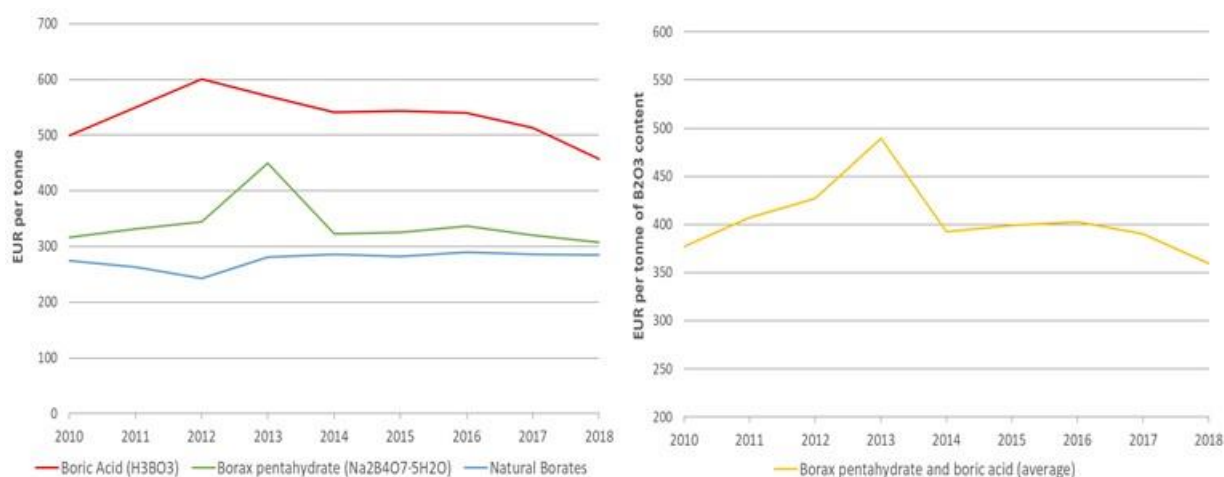
Prices had been stable in the 1990s up to mid-2000s, reflecting a balance between supply and demand in the market (Carpenter and Kistler 2006). Since then, borate prices are following a downward trend as it is demonstrated in Figure 78.



**Figure 78. Borates historical price volatility<sup>41</sup> in the United States (indexed to the 1998 unit value), yearly average (in USD/t of  $B_2O_3$  content) (USGS 2017).**

The unit value of EU imports for natural borates is relatively stable since 2010 ranging between EUR 243 and 290 per t in the period 2010-2018 as an annual average (see Figure 79). For the most commonly traded refined borates (boric acid and borax pentahydrate), it is noteworthy an increase in the imports unit value from 2010 to 2013 when the average imports unit value of boric acid and borax pentahydrate reached peaked at EUR 490 per t of boric oxide ( $B_2O_3$ ), followed by a generally downward trend up to 2018. In 2018, the average imports unit value of boric acid and borax pentahydrate was EUR 360 per t of  $B_2O_3$ .

<sup>41</sup> The unit value in the US is defined as the estimated value of apparent consumption in U.S. dollars of one tonne of  $B_2O_3$  content



**Figure 79. Unit value<sup>42</sup> of EU imports of borate commodities, yearly average (left in EUR per t, right in EUR/t of B<sub>2</sub>O<sub>3</sub> content). (Eurostat Comext 2019)**

## 6.3 EU demand

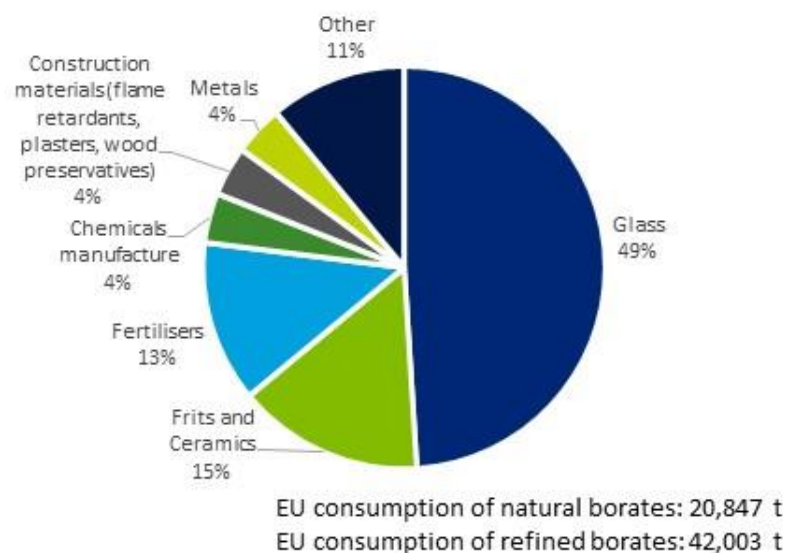
### 6.3.1 EU consumption

The total EU apparent consumption of borates between 2012 and 2016 was estimated at 62,850 t per year (B content). Natural borates account for one-third of the total consumption (20,847 t/y), and processed/refined borates for two-thirds (42,003 t). In terms of volume, the average annual consumption for the period 2012-2016 is 112,000 t for natural borates (Eurostat Comext 2019), and 301,000 t for processed/refined borates (WITS 2019). The EU is fully dependent on imports for its consumption (import reliance of 100%).

### 6.3.2 Uses and end-uses of borates in the EU

Borates are a key input material in the production of fibreglass insulation, textile fibreglass, borosilicate glass, ceramics and fertilisers. These applications account for over three-quarters of borates consumption. Borates also have several other applications within the construction, metallurgy and chemicals industries. The borates imported in the EU are mostly embodied in glass products. The second single most common application of borates imports is the supply to ceramics and frits industry followed by fertilisers. Other products are construction materials, abrasives, catalysts, coatings, detergents, etc. The EU end-uses of borates in 2012 are shown in Figure 80.

<sup>42</sup> Not corrected for inflation



**Figure 80: EU end uses in 2012 (IMA Europe 2016) and EU consumption of borates (average 2012-2016, in B content (Eurostat Comext 2019)(WMD 2019)(UN Comtrade 2019)(WITS 2019).**

The end-use of borates are described below (BIO Intelligence Service 2015) (IMA Europe 2016) (USGS 2018) (SCREEN workshop 2019):

- **Glass:** The glass industry dominates the demand for borates worldwide. Natural (e.g. colemanite concentrates, ulexite) or refined borates (e.g. borax pentahydrate, boric acid) can be added as raw materials during the manufacturing of glass depending on the application and the required quality. In Europe, borax pentahydrate is the dominant raw material for boron addition to the glass melt (BIO Intelligence Service 2015). The boron in borosilicate glass imparts increased mechanical strength and resistance to chemical corrosion, as well as improved resistance to high temperatures and thermal shocks due to a low coefficient of thermal expansion. In borosilicate glasses the  $B_2O_3$  content typically ranges between 7% and 15% (Scalet et al. 2013), but can be as high as 30% (USGS 2018). Glass fibre production includes insulation glass fibre (glass wool) and continuous filament glass fibre (textile grade). E-glass composition typically ranges from 5% to 10% of  $B_2O_3$  content (Scalet et al. 2013)(RPA 2008). Furthermore, boron addition to the glass melt facilitates the production process as it lowers the glass batch melting temperature, favours fiberisation and inhibits crystallisation of the glass.

Glass products can be grouped in two categories:

- **Insulation glass:** Insulation fiberglass (IFG) used in construction, vehicles, appliances and machinery for thermal and acoustic insulation;
- **Other glass (excl. insulation):** Textile fiberglass (TFG) USED in the manufacture of composite materials (glass-reinforced plastics), and borosilicate glass used in heat-resistant glass cookware and glass panels (e.g. for oven doors), laboratory glassware, pharmaceutical packaging, light bulbs, solar panels, LCD screens etc.;

- **Frits and Ceramics:** Borates are essential ingredient to produce frits used by the ceramic industry in ceramic glazes and enamels for chemical, thermal cycling, and wear resistance;

- **Fertilisers:** Boron is an essential micronutrient for plant growth, crop yield and seed development. Although only low amounts of boron are required, its deficiency in soil can have severe effects on the crops;

- **Wood preservatives:** Borates are used to treat wood to ward off insects and other pests;

- **Detergents:** Borates are used in laundry detergents, household and industrial cleaning products. Borates enhance stain removal and bleaching, provide alkaline buffering, soften water and improve surfactant performance.

- *Chemicals (excl. Fertilisers, wood preservatives and detergents)*: Used for chemicals such as fire retardants;
- *Industrial fluids*: Used for metalworking fluids, and other fluids used in cars, antifreeze, braking fluid etc.;
- *Metals*: Boron is used as an additive for steel and other ferrous metals as its presence ensures higher strength at a lower weight.

Relevant industry sectors are described using the NACE sector codes in Table 32.

**Table 32: Borate applications, 2-digit and examples of associated 4-digit NACE sectors, and value-added per sector (Eurostat 2019)**

Applications	2-digit NACE sector	Value added of NACE 2 sector (M€)	Examples of 4-digit NACE sector(s)
Glass	C23 - Manufacture of other non-metallic mineral products	57,255	C2314 - Manufacture of glass fibres C2319 - Manufacture and processing of other glass, including technical glassware
Frits and Ceramics	C23 - Manufacture of other non-metallic mineral products	57,255	C2331 - Manufacture of ceramic tiles and flags
Fertilisers	C20 - Manufacture of chemicals and chemical products	105,514	C2015 - Manufacture of fertilisers and nitrogen compound
Chemicals manufacture	C20 - Manufacture of chemicals and chemical products	105,514	C1610- Sawmilling and planing of wood
Construction materials (flame retardants, plasters, wood preservatives)	C20 - Manufacture of chemicals and chemical products	105,514	C2059- Manufacture of other chemical products n.e.c.
Chemicals manufacture	C20 - Manufacture of chemicals and chemical products	105,514	C2059- Manufacture of other chemical products n.e.c.
Metals	C24 - Manufacture of basic metals	55,426	C2410- Manufacture of basic iron and steel and of ferro-alloys

### 6.3.3 Substitution

Borates may be substituted in fibreglass (boron-free E-glass), or fibreglass insulation may be replaced itself by alternative materials such as cellulose, foams, and mineral wool (Tercero et al. 2018) (USGS 2019a). However, the extent of borates' use is a limitation in itself and, practically, there are no commercially available substitutes for fibreglass insulation (Tercero et al. 2018). According to (IMA Europe 2016), eliminating boron from fibreglass production is not possible without affecting the glass fibre properties and increasing production costs.

Furthermore, no practical substitutes are available for heat-resistant glass, nor for frits and ceramics that have to resist thermal shocks (Tercero et al. 2018). For those frits and ceramics that are to be used in tiles and floors, substitution is theoretically possible (Tercero et al. 2018) but no information is available on technically or economically viable alternative applications. According to (IMA Europe 2016), there are no substitutes in ceramic, or enamel glazes as the benefits provided by B<sub>2</sub>O<sub>3</sub> in glaze production cannot be replaced by other oxides.



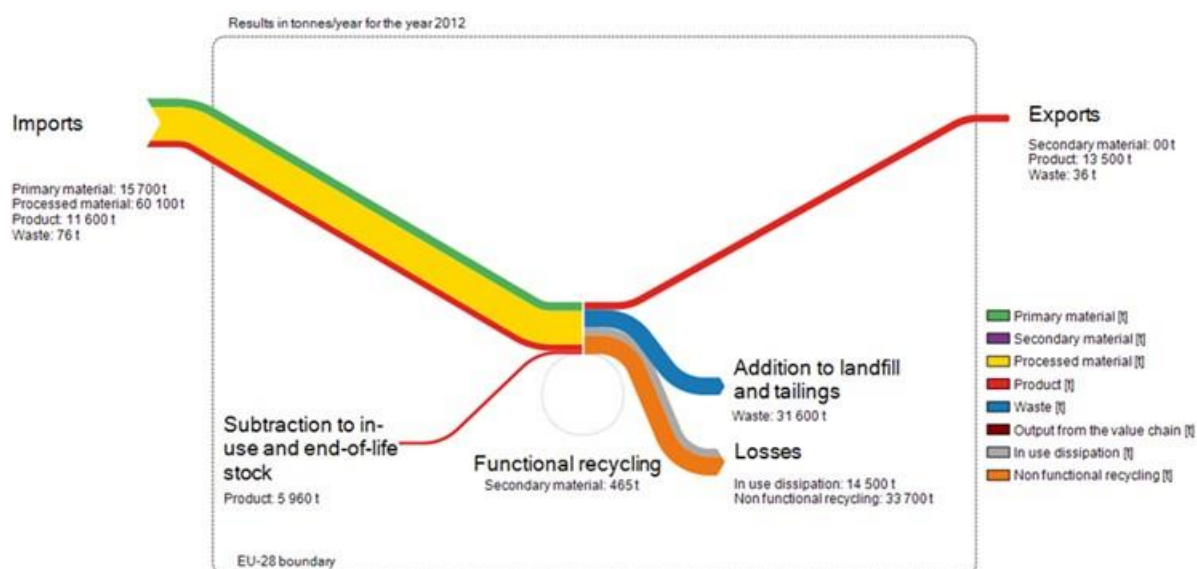
Finally, no substitution is possible in fertilisers because of the unique biological function of boron (Tercero et al. 2018).

In the criticality assessment, no substitution is considered available for the use of borates in the applications of 'Glass', 'Frits and ceramics' and 'Fertilisers'. The rest of the applications were not assessed due to less than 10 % share in total end uses. However, substitutes exist for wood preservatives (Tercero et al. 2018), soaps (sodium and potassium salts of fatty acids), detergents (sodium percarbonate which requires a lower temperature to undergo hydrolysis) and bleaches (chlorine) (USGS 2019a)(Graedel et al. 2015b). Finally, boron replacement in metal applications seems impractical due to the numerous uses (Tercero et al. 2018a).

On a scale of 0 to 100<sup>43</sup>, the substitution potential of boron has been assessed as 41 by (Graedel et al. 2015).

### 6.3.4 EU supply chain

The boron flows through the EU economy in 2012 are demonstrated in Figure 81.

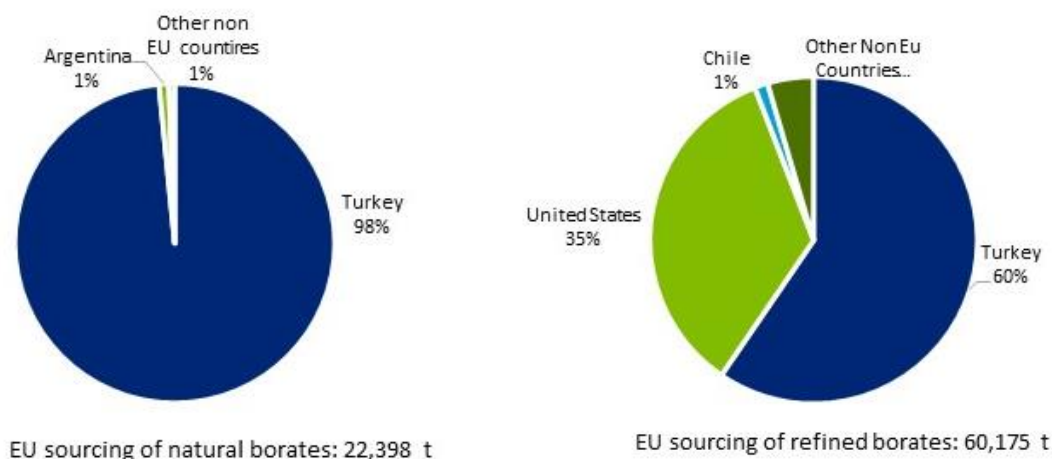


**Figure 81: Simplified MSA of boron flows in the EU in 2012 (BIO Intelligence Service 2015).**

The EU does not extract borates (WMD 2019) and has no known reserves (BIO Intelligence Service 2015a). Therefore, the EU is entirely reliant on imports of primary products (import reliance of 100%). Likewise, there are no manufacturing/processing plants to refine borates in the EU (IMA-Europe, 2016) (SCREEN workshops 2019). However, it has to be mentioned that boric acid is produced in Italy from geothermal springs. Although it was the sole source of natural boric acid in the mid-19th century, the current contribution to the EU borates supply is minimal (RPA 2008) (Helvaci 2005).

<sup>43</sup> On this scale, zero indicates that exemplary substitutes exist for all major uses and 100 indicates that no substitute with even adequate performance exists for any of the major uses

The leading supplier of the EU for both natural and refined borates is Turkey, with a share of 98% and 60% of the EU sourcing, respectively. The US is a significant supplier of refined borates with a share of 35% of EU supply (Figure 82).



**Figure 82: EU sourcing of borates. Average 2012-2016 (Eurostat Comext 2019).**

### 6.3.5 Supply from primary materials

#### 6.3.5.1 Geology, resources and reserves of borates

**Geological occurrence:** Borates are naturally occurring minerals containing boron (B). Boron does not occur naturally as a native element but is found in combination with oxygen and other elements in salts, commonly called "borates". Boron is a relatively rare element in nature, and the average content in the Earth's crust is reported between 10 (Helvacı 2017) and 17 ppm (Rudnick and Gao 2014). There are over 250 borate minerals occurring naturally, the most common being sodium, calcium, or magnesium salts (Helvacı 2017). Four of these account for 90% of the minerals used by the industry: the sodium borates tincal and kernite, the calcium borate colemanite, and the sodium-calcium borate ulexite (USGS 2018). Ore quality is typically measured as a function of its diboron trioxide ( $B_2O_3$ ) equivalent content.

Deposits of borates are generally associated with arid climates and volcanically active areas; the largest are found in Turkey and the Mojave Desert in California of the United States. In the Puna region of the Andean belt of South America, which includes parts of Argentina, Peru, Bolivia, and Chile, commercial deposits of borates occur in brines (USGS 2018).

There is no information available on deposits of borates in the EU. In the geothermal springs of the Maremma region of Tuscany in Italy (Lardarello), natural steam carries boric acid recoverable as sassolite (Helvacı 2005).

**Global resources and reserve<sup>44</sup>:** The estimated known reserves of borates worldwide are about 1,093,000 kt in boron content (USGS 2019a). Approximately 75-80% of the

<sup>44</sup> There is no single source of comprehensive evaluations for resources and reserves that apply the same criteria to deposits of borates in different geographic areas of the EU or globally. The USGS collects information about the quantity and quality of mineral resources but does not directly measure reserves, and companies or governments do not directly report reserves to the USGS. Individual companies may publish regular mineral resource and reserve reports, but reporting is done using a variety of systems of reporting depending on the location of their operation, their corporate identity and stock market requirements. Translations between national reporting codes are possible by application of the CRIRSCO template which is also consistent with the United Nations Framework Classification (UNFC) system. However, reserve and resource data are changing

global boron reserves are located in Turkey, which are the world's highest-grade deposits of colemanite, ulexite and tincal with grades ranging from 25 to 30% of B<sub>2</sub>O<sub>3</sub> (boric oxide) (Helvacı 2017).

**Table 33: Global reserves of borates in 2018 (USGS 2019<sup>a</sup>)**

Country	Reserves (kt of boron)	Percentage of the total (%)
Turkey	950,000	87%
Unites States	40,000	4%
Russia	40,000	4%
Chile	35,000	3%
China	24,000	2%
Peru	4,000	<1%
Argentina	NA	-
Bolivia	NA	-
Kazakhstan	NA	-
World total <sup>45</sup>	1,093,000	100%

**EU resources and reserves:** There are no known resources of borates in the EU. Table 34 presents available data on borate resources in Europe.

**Table 34: Resources of borates in Europe**

Country	Classification	Quantity (million t of ore)	Grade (% B <sub>2</sub> O <sub>3</sub> )	Reporting code	Reporting date	Source
Serbia	Indicated	5.6	30.8	NI 43-101	04/2015	(Minerals4EU 2019)
	Inferred	6.2	28.8			
	Indicated	52.4	19.2	JORC	12/2016	(Rio Tinto 2017) <sup>46</sup>
	Inferred	83.3	13.0			

### 6.3.5.2 Mining and refining of borates

Most of the world's commercial borate deposits are mined by open-pit methods, generally using truck and shovel or backhoe equipment (Carpenter and Kistler 2006).

Some applications permit the use of unrefined borates, such as colemanite and ulexite. However, natural borates often require refining as the ores are not of sufficient quality. High purity borax or boric acid are the main forms consumed by manufacturing industries for most applications.

Processing techniques depend on both the scale of the operation and the ore type (Helvacı 2005). The basic processing steps used to convert natural borates to refined products consist of ore crushing, leaching the ore in either hot water or acid, filtration to to remove insoluble impurities, cooling the concentrated borate solutions, dewatering to produce a moist cake of boric acid, washing and drying (Carpenter and Kistler 2006) . Several commercial forms of refined borates (or primary boron chemicals) exist:

---

continuously as exploration and mining proceed and are thus influenced by market conditions and should be followed continuously.

<sup>45</sup>

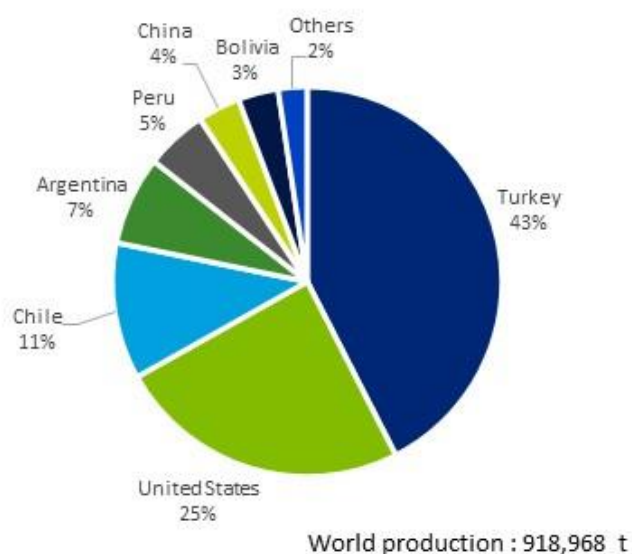
The world total is given, even though reserves are not reported to the USGS in a consistent manner by all countries (USGS, 2019a)

<sup>46</sup> Jadar project

- high purity sodium borates (borax pentahydrate, borax decahydrate, anhydrous borax);
- high-purity boric acid and boron oxide (anhydrous boric acid).

### 6.3.5.3 World and EU production of natural borates

In the period 2012-2016, the average world mine production was about 918,968 t of boron minerals (in B content). In terms of volume, world production of boron minerals amounted to 4,594,840 t on average over the 2012-2016 period (WMD 2019). Turkey and the United States are the leading producers of natural borates accounting for more than two-thirds of natural borates output, followed by Argentina and Chile (Figure 83). There is no mining of borate minerals within the EU.



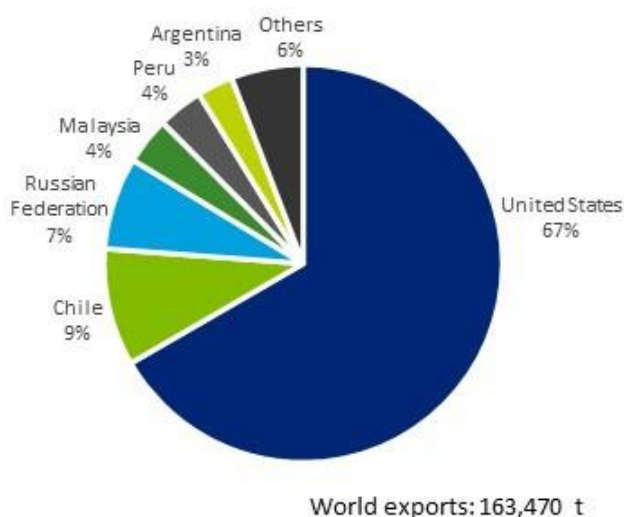
**Figure 83: Global production of natural borates. Average for the years 2012-2016 (in B content) (WMD 2019)**

### 6.3.5.4 World and EU production of refined borates

There is no publicly available data on the production of refined borates. Based on estimation from the global trade data as reported by UN Comtrade (2019), US is the dominant supplier of refined borates accounting for 67% of the total world exports. The average annual quantity of the processed borate products traded over 2012-2016 is around 163,500 t of borate content. The trade codes used for the indirect estimation of world production shares are:

- Oxides of boron, boric acids (HS6 281000, B content 17%). World exports 508,125 t by volume;
- Borates, disodium tetraborate (refined borax), anhydrous (HS6 284011, B content 21%). World exports 68,896 t by volume;
- Borates, disodium tetraborate (refined borax), other than anhydrous (HS6 284019, B content: 12%). World exports 701,756 t by volume;

Refined borates are not produced in the EU (IMA-Europe, 2016) (SCREEN workshops 2019).



**Figure 84: Estimated distribution of world production of processed borates. Average for the period 2012-2016 (in B content). (UN Comtrade 2019)**

### 6.3.6 Supply from secondary materials/recycling

Because of the nature of end uses, boron/borates functional recycling is not possible as products are consumed with the use (e.g. fertilisers, chemicals and detergents), or because non-functional recycling only occurs. For instance, separation of borosilicate glass from the boron-free container and flat glass is not possible and, as a result, waste borosilicate glass will end up in the manufacture of normal glass, causing defects in the final product. Moreover, waste from ceramics is mostly used as a construction material (BIO Intelligence Service 2015). As an exception, the recycling of biogenic wastes (e.g. manure or other animal by-products, bio- and food wastes) can be considered as functional recycling because it may replace boron from industrial fertilisers (Mathieux et al. 2017). The EoL-RIR (End-of-Life Recycling Input Rate) for boron is less than 1% (SCREEN workshops 2019).

**Table 35: Material flows relevant to the EOL-RIR of borates<sup>47</sup> in 2012. Data from (BIO Intelligence Service 2015).**

MSA Flow	Value (t)
B.1.1 Production of primary material as the main product in EU sent to processing in EU	0
B.1.2 Production of primary material as by-product in EU sent to processing in EU	0
C.1.3 Imports to EU of primary material	15,739
C.1.4 Imports to EU of secondary material	0
D.1.3 Imports to EU of processed material	60,050
E.1.6 Products at end of life in EU collected for treatment	65,778
F.1.1 Exports from EU of manufactured products at end-of-life	36
F.1.2 Imports to EU of manufactured products at end-of-life	75
G.1.1 Production of secondary material from post-consumer functional recycling in EU sent to processing in EU	0
G.1.2 Production of secondary material from post-consumer functional recycling in EU sent to manufacture in EU	464

<sup>47</sup>  $EOL-RIR = (G.1.1 + G.1.2) / (B.1.1 + B.1.2 + C.1.3 + D.1.3 + C.1.4 + G.1.1 + G.1.2)$

## 6.4 Other considerations

---

### 6.4.1 Environmental and health and safety issues

Certain boron compounds have been identified as Substances of Very High Concern (SVHC) under Regulation (EC) 2006/1997 (REACH) and have been included in the candidate list for authorisation due to their classification as toxic for reproduction, cat. 1B (meeting the criteria of Art. 57 (c) of the REACH Regulation (ECHA 2019a)).

The Candidate List of Substances of Very High Concern (SVHC), as published on ECHA's website, contains the following borates:

- Boric acid, anhydrous disodium tetraborate and tetraboron disodium heptaoxide-hydrate were included in 2010;
- Diboron trioxide and Lead bis (tetrafluoroborate) were included in the same list in 2012;
- Sodium perborate; perboric acid, sodium salt and Sodium peroxometaborate included in 2014;
- Disodium octaborate added in the list in 2018.

Several boric acids and borates cannot be placed on the market or used as a substance, as constituent of another substance or in mixtures for supply to the general public when the individual concentration in the substance or mixture is equal to or greater than 0,3%. The packaging must be marked visibly, legible and indelibly "Restricted to professional users"<sup>48</sup>.

Companies may have immediate legal obligations following the inclusion of a substance in the Candidate List as explained on ECHA's website, in particular, specific communication requirements (ECHA 2019b). Inclusion on Annex XIV (the Authorization list) is not automatically triggered by the inclusion on the Candidate List. Currently (July 2019), ECHA has recommended to the European Commission from the "Candidate List" as priority substances for inclusion in Annex XIV of REACH (the "Authorisation List") the following borates (ECHA, 2019c):

- Disodium tetraborate, anhydrous (from July 2015);
- Sodium perborate; perboric acid, sodium salt (from November 2016);
- Sodium peroxometaborate (from November 2016).

As regards the potential impact of REACH on defence applications, the European Defence Agency reports that boric acid has very critical uses in surface treatment, i.e. in electrolytic deposition of metals, acidity regulators, cleaning, anodising. It is also useful for metalworking fluids and brazing fluxes as well as in submarine propulsion and for the control of nuclear reactions. Another relevant issue is related to boron oxide that is an essential reagent in the manufacturing process of gallium arsenide (GaAs), which is a semiconductor compound with some electronic properties superior to those of silicon (EDA 2018).

EU OSH requirements exist to protect workers' health and safety, employers need to identify which hazardous substances they use at the workplace, carry out a risk assessment and introduce appropriate, proportionate and effective risk management measures to eliminate or control exposure, to consult with the workers who should receive training and, as appropriate, health surveillance<sup>49</sup>.

According to the Committee for Risk Assessment (RAC) opinion<sup>50</sup> adopted on 20/09/2019, boric acid and sodium borates are classified as follows:

---

<sup>48</sup> Annex XVII entry 30 and Appendix 6 of Regulation (EC) 1907/2006 (REACH).

<sup>49</sup> <https://ec.europa.eu/social/main.jsp?catId=148>

<sup>50</sup> [https://www.echa.europa.eu/documents/10162/23665416/clh\\_opinion\\_Boric+acid+and+sodium+borates\\_13456\\_en.pdf/584263da-199c-f86f-9b73-422a4f22f1c3](https://www.echa.europa.eu/documents/10162/23665416/clh_opinion_Boric+acid+and+sodium+borates_13456_en.pdf/584263da-199c-f86f-9b73-422a4f22f1c3)

- boric acid: Repr. 1B
- diboron trioxide: Repr. 1B (GCL of 0.3%)
- tetraboron disodium heptaoxide, hydrate: Repr. 1B (GCL of 0.3%)
- disodium tetraborate decahydrate: Repr. 1B (GCL of 0,3%)
- disodium tetraborate pentahydrate: Repr. 1B (GCL of 0.3%)

### 6.4.2 Contribution to low-carbon technologies

A role for borates in the implementation of the European Commission’s long-term strategy for a modern, competitive, prosperous and climate-neutral economy by 2050<sup>51</sup>, is identified in wind turbines, as boron is a key ingredient in the most powerful magnet material, namely neodymium-iron-boron (NdFeB). This magnet is used to manufacture permanent magnets for synchronous generators (PMSG), which are used in all major wind turbine configurations (Blagoeva et al. 2016).

Moreover, insulation through the use of glass wool, coupled with high-performance glazing in buildings, has the potential to enable more than 80% energy savings from buildings (Wyns, Khandekar, and Robson 2018).

A fast growing application of borosilicate glass is in solar thermal heating; these are used in both domestic and industrial technologies. In the former, borosilicate glass tubes contain a solar collector in order to capture the energy. In the latter, these tubes are used to carry heat transfer fluids.

Finally, boron is identified as a material that can be used for storage of hydrogen in fuel cell and hydrogen-related technologies (Blagoeva et al. 2019).

### 6.4.3 Socio-economic issues

The governance level in Turkey, the dominant supplier of natural borates for the EU, is low especially in the “political stability and absence of violence/terrorism” area, with a sharp deterioration of this indicator in the decade 2006-2016 (World Bank 2018).

## 6.5 Comparison with previous EU assessments

The assessment has been conducted using the same methodology as for the 2017 list. In the current assessment, the supply risk has been analysed at the mine and, additionally to the 2017 assessment, at the processing stage. The results of this and earlier assessments are shown in Table 36.

**Table 36: Economic importance and supply risk results for borates in the assessments of 2011, 2014, 2017, 2020 (European Commission 2011);(European Commission 2014); (European Commission 2017)**

Assessment	2011		2014		2017		2020	
Indicator	EI	SR	EI	SR	EI	SR	EI	SR
Borates	5.0	0.6	5.7	1.0	3.1	3.0	3.5	3.2

The results of the previous assessments are not directly comparable due to the introduction of a revised methodology in the 2017 assessment. For example, the economic importance appears reduced in the 2017 assessment as the value-added considered in the 2017 criticality assessment corresponds to a 2-digit NACE sector rather than a ‘megasector’ (which was used in the previous assessments).

<sup>51</sup>

[https://ec.europa.eu/clima/policies/strategies/2050\\_en](https://ec.europa.eu/clima/policies/strategies/2050_en)

In the current assessment, the higher supply risk is identified for the mine stage (SR=3.2) than the processing stage (SR=1.8) reflecting a higher EU supply concentration at the mining stage in comparison to the refining stage. The overall supply risk for borates is considered for the stage with the highest value, i.e. SR=3.2. The supply risk has increased compared to 2017 exercise due to the growing supply concentration, both global and for the EU.

The Economic Importance indicator (EI) is higher in the current assessment compared to the 2017 exercise. This is mainly due to the results scaling step<sup>52</sup>, as the value-added of the largest manufacturing sector in the current assessment is lower as it corresponds to 27 Member States (i.e. excluding UK), whereas in the 2017 assessment it was related to 28 Member States. The slightly different allocation of shares to each end use sector in comparison to the 2017 assessment, and the correspondence of the application "Wood preservatives" to the C20 2-digit NACE sector "C20 - Manufacture of chemicals and chemical products" instead of "C16 - Manufacture of wood and of products of wood and cork, except furniture" as in the 2017 assessment, had a negligible effect in the increase of EI.

## 6.6 Data sources

---

For the stage of extraction (natural borates), data developed by the Austrian Ministry for Sustainability and Tourism and the International Organising Committee for the World Mining Congress were used (World Mining Data). Data for refined borate production are not available. Thus, the global production of refined borates was approximated/modelled from world exports of refined borate products (UN Comtrade) based on common hypotheses and calculation of boron amount by stoichiometric principles. Eurostat (Comext) was the source of data for EU trade flows of natural borates. For refined borates, trade data were sourced from the World Integrated Trade Solution (WITS) database developed by the World Bank, in collaboration with the United Nations Conference on Trade and Development (UNCTAD). For the analysis of EU borates consumption per application, data provided by IMA Europe in the context of the 2015 MSA study and the 2017 criticality assessment were used (IMA Europe 2016).

### 6.6.1 Data sources used in the factsheet

BIO Intelligence Service (2015) Study on Data for a Raw Material System Analysis: Roadmap and Test of the Fully Operational MSA for Raw Materials. Available at: <https://ec.europa.eu/jrc/en/scientific-tool/msa>.

Blagoeva, D. et al. (2016) Assessment of potential bottlenecks along the materials supply chain for the future deployment of low-carbon energy and transport technologies in the EU. Wind power, photovoltaic and electric vehicles technologies, time frame: 2015-2030. doi: 10.2790/08169.

Blagoeva, D. et al. (2019) Materials dependencies for dual-use technologies relevant to Europe's defence sector. doi: 10.2760/570491.

Carpenter, S. and Kistler, R. (2006) Industrial minerals & rocks: commodities, markets, and uses. Borates. 7th edn. Edited by S. Kogel, J.E., Trivedi, N.C., Barker, J.M. and Krukowski. Colorado, USA: Society for Mining, Metallurgy and Exploration Inc.

---

<sup>52</sup> The results are scaled by dividing the calculated EI score by the value of the largest manufacturing sector NACE Rev. 2 at the 2-digit level and multiplied by 10, in order to reach the value in the scale between 0-10.



ECHA (2019a) Candidate List of substances of very high concern for Authorisation. Available at: <https://www.echa.europa.eu/candidate-list-table> (Accessed: 7 July 2019).

ECHA (2019b) Summary of obligations resulting from inclusion of SVHCS in the Candidate List. Available at: <https://echa.europa.eu/candidate-list-obligations> (Accessed: 7 July 2019).

EDA (2018) Position Paper On the impact of the entanglement of REACH Regulation , Critical Raw Materials and Circular Economy on European Defence.

Eurostat Comext (2019) Easy Comext database. Available at: <http://epp.eurostat.ec.europa.eu/newxtweb/>.

European Commission (2011) Critical raw materials. Available at: [https://ec.europa.eu/growth/sectors/raw-materials/specific-interest/critical\\_en](https://ec.europa.eu/growth/sectors/raw-materials/specific-interest/critical_en) (Accessed: 8 July 2019).

European Commission (2014) Report on critical raw materials for the EU - Critical raw materials profiles. Available at: <https://ec.europa.eu/docsroom/documents/11911/attachments/1/translations/en/renditions/pdf>.

European Commission (2017) Study on the review of the list of critical raw materials. Critical Raw Material Factsheets. European Commission. doi: 10.2873/398823.

European Commission (2019) Negotiations and agreements. Available at: <http://ec.europa.eu/trade/policy/countries-and-regions/negotiations-and-agreements/> (Accessed: 7 July 2019).

Eurostat Comext (2019) Easy Comext database. Available at: <http://epp.eurostat.ec.europa.eu/newxtweb/>.

Eurostat (2019) Annual detailed enterprise statistics for industry (NACE Rev. 2, B-E). Available at: [https://ec.europa.eu/eurostat/en/web/products-datasets/-/SBS\\_NA\\_IND\\_R2](https://ec.europa.eu/eurostat/en/web/products-datasets/-/SBS_NA_IND_R2) (Accessed: 7 July 2019).

Fastmarkets IM (2019) Discontinuation of four industrial mineral price assessments. Available at: <https://www.indmin.com/Article/3854539/PRICING-NOTICE-Discontinuation-of-four-industrial-mineral-price-assessments-extended-consultation.html> (Accessed: 8 July 2019).

Global Trade Alert (2018) Argentina: Government sets new export duties. Available at: <https://www.globaltradealert.org/state-act/31905/argentina-government-sets-new-export-duties> (Accessed: 28 August 2019).

Graedel, T. et al. (2015a) 'On the materials basis of modern society', Proceedings of the National Academy of Sciences, 112(20). doi: 10.1073/pnas.1312752110.

Graedel, T. et al. (2015b) 'On the materials basis of modern society. Supporting information file', Proceedings of the National Academy of Sciences of the United States of America. National Academy of Sciences, pp. 6295–300. doi: 10.1073/pnas.1312752110.

Helvacı, C. (2005) 'Minerals/Borates', in Encyclopedia of Geology, pp. 510–522. doi: 10.1016/b0-12-369396-9/00279-3.

Helvacı, C. (2017) 'Borate deposits: An overview and future forecast with regard to mineral deposits', Journal of Boron, 2(2), pp. 59–70. Available at: <https://dergipark.org.tr/boron/issue/31236/302668>.

IMA Europe (2011) 'Borates'. Available at: <https://www.ima-europe.eu/content/borate-fact-sheet>.

IMA Europe (2016) 'Feedback to the 2017 Criticality assesment. Data from manufacturing companies using borates'.

Mathieux, F. et al. (2017) Critical raw materials and the circular economy - Background report. EUR 28832 EN, Publications Office of the European Union, Luxembourg. doi: 10.2760/378123.

McCormick, B. M. (2018) 'Two lions ': The modern borate duopoly, Fastmarkets IM. Available at: <https://www.indmin.com/Article/3806819/Two-lions-The-modern-borate-duopoly.html> (Accessed: 7 July 2019).

Minerals4EU (2019) European Minerals Yearbook. Available at: [http://minerals4eu.brgm-rec.fr/m4eu-yearbook/theme\\_selection.html](http://minerals4eu.brgm-rec.fr/m4eu-yearbook/theme_selection.html).

OECD (2019) Export Restrictions on Industrial Raw Materials. Available at: [https://qdd.oecd.org/subject.aspx?Subject=ExportRestrictions\\_IndustrialRawMaterials](https://qdd.oecd.org/subject.aspx?Subject=ExportRestrictions_IndustrialRawMaterials) (Accessed: 5 July 2019).

Rio Tinto (2014) 'A global outlook for borates'. Available at: <http://www.indmin.com/events/download.ashx/document/speaker/6613/a0ID000000X0jnzMAB/Presentation>.

Rio Tinto (2015) Annual report 2015. Available at: [https://www.riotinto.com/documents/RT\\_Annual\\_Report\\_2015.pdf](https://www.riotinto.com/documents/RT_Annual_Report_2015.pdf) (Accessed: 9 July 2019).

Rio Tinto (2017) 'Notice to ASX Increase to Jadar Project Mineral Resources', (March). Available at: [https://www.riotinto.com/documents/170302\\_Increase\\_to\\_Jadar\\_Project\\_Mineral\\_Resources.pdf](https://www.riotinto.com/documents/170302_Increase_to_Jadar_Project_Mineral_Resources.pdf).

Rio Tinto (2018a) 'Jadar Project fact sheet'. Available at: [www.riotinto.com/Jadar](http://www.riotinto.com/Jadar).

Rio Tinto (2018b) Rio Tinto annual report 2018. Available at: [http://www.riotinto.com/documents/RT\\_2018\\_annual\\_report.pdf](http://www.riotinto.com/documents/RT_2018_annual_report.pdf) (Accessed: 7 July 2019).

RPA (2008) Assessment of the Risk to Consumers from Borates and the Impact of Potential Restrictions on their Marketing and Use. Available at: [https://ec.europa.eu/growth/content/assessment-risk-consumers-borates-and-impact-potential-restrictions-their-marketing-and-0\\_it](https://ec.europa.eu/growth/content/assessment-risk-consumers-borates-and-impact-potential-restrictions-their-marketing-and-0_it).

Rudnick, R. L. and Gao, S. (2014) Composition of the Continental Crust, Treatise on Geochemistry: Second Edition. Elsevier Ltd. doi: 10.1016/B978-0-08-095975-7.00301-6.

Scalet, B. M. et al. (2013) Best Available Techniques (BAT) Reference Document for the Manufacture of Glass, Joint Research Centre Reference Report. doi: 10.2791/69502.

SCRREEN workshop (2019) 'Validation workshop on Critical Raw Materials, 10-12 September 2019, Thon Hotel Brussels City Centre'. Brussels.

Tercero, L. et al. (2018) Critical Raw Material substitution profiles. SCRREEN project D5.1., SCRREEN - D5.1. Available at: <http://screen.eu/wp-content/uploads/2018/05/SCRREEN-D5.1-CRM-profiles.pdf>.

UN Comtrade (2019) International Trade Statistics Database. Available at: <https://comtrade.un.org/> (Accessed: 8 July 2019).

USGS (2017) 'Historical Statistics for Mineral and Material Commodities in the United States- Boron'. U.S. Geological Survey. Available at: <https://www.usgs.gov/centers/nmic/historical-statistics-mineral-and-material-commodities-united-states#boron>.

USGS (2018) 2016 Minerals Yearbook: Boron. Available at: <https://www.usgs.gov/centers/nmic/boron-statistics-and-information>.

USGS (2019a) 'Mineral commodity summaries. Boron', in. Available at: <https://www.usgs.gov/centers/nmic/boron-statistics-and-information>.

USGS (2019b) Mineral Commodity Summaries 2019. U.S Geological Survey. doi: 10.1007/978-3-540-47108-0-4.

WITS (2019) World Integrated Trade Solution database. Data on Export, Import, Tariff, NTM. Available at: <https://wits.worldbank.org/> (Accessed: 17 October 2019).

WMD (2019) World Mining Data 2019, Reichl, C.; Schatz, M; Zsak, G. Iron and Ferro Alloy Metals, non Ferrous Metals, Precious Metals, Industrial Minerals, Mineral Fuels. Austrian Federal Ministry of Sustainability and Tourism. [online] Available at: [www.en.bmwfw.gv.at/Energy/WorldMiningData/Seiten/default.aspx](http://www.en.bmwfw.gv.at/Energy/WorldMiningData/Seiten/default.aspx)

World Bank (2018) Aggregate Governance Indicators 1996-2017, Worldwide Governance Indicators. Available at: <http://info.worldbank.org/governance/WGI/#home> (Accessed: 7 July 2019).

Wyns, T., Khandekar, G. and Robson, I. (2018) Industrial Value Chain: a Bridge Towards a Carbon Neutral Europe. Available at: <http://www.euroalliages.com/web/low-carbon-economy/1011306087/list1187970084/f1.html>.

### **6.6.2 Data sources used in the criticality assessment**

BIO Intelligence Service (2015) Study on Data for a Raw Material System Analysis: Roadmap and Test of the Fully Operational MSA for Raw Materials. Available at: <https://ec.europa.eu/jrc/en/scientific-tool/msa>.

European Commission (2010) European Commission Scientific Committee on Consumer Safety "Opinion on Boron Compounds". June 2010 (Boron contained in Borates). B content pag12

European Commission (2014) Report on critical raw materials for the EU - Critical raw materials profiles. Available at: <https://ec.europa.eu/docsroom/documents/11911/attachments/1/translations/en/renditions/pdf>.

European Commission (2017) Study on the review of the list of critical raw materials. Critical Raw Material Factsheets. European Commission. doi: 10.2873/398823.

Eurostat Comext (2019) Easy Comext database. Available at: <http://epp.eurostat.ec.europa.eu/newxtweb/>.

Eurostat (2019) Annual detailed enterprise statistics for industry (NACE Rev. 2, B-E). Available at: [https://ec.europa.eu/eurostat/en/web/products-datasets/-/SBS\\_NA\\_IND\\_R2](https://ec.europa.eu/eurostat/en/web/products-datasets/-/SBS_NA_IND_R2) (Accessed: 7 July 2019).

Helvacı, C. (2005) 'Minerals/Borates', in Encyclopedia of Geology, pp. 510–522. doi: 10.1016/b0-12-369396-9/00279-3.

OECD (2019) Export Restrictions on Industrial Raw Materials. Available at: [https://qdd.oecd.org/subject.aspx?Subject=ExportRestrictions\\_IndustrialRawMaterials](https://qdd.oecd.org/subject.aspx?Subject=ExportRestrictions_IndustrialRawMaterials) (Accessed: 5 July 2019).

SCRREEN workshop (2019) 'Validation workshop on Critical Raw Materials, 10-12 September 2019, Thon Hotel Brussels City Centre'. Brussels.

UN Comtrade (2019) International Trade Statistics Database. Available at: <https://comtrade.un.org/> (Accessed: 8 July 2019).

USGS (2019a) 'Mineral commodity summaries. Boron', in. Available at: <https://www.usgs.gov/centers/nmic/boron-statistics-and-information>.

WMD (2019) World Mining Data 2019, Reichl, C.; Schatz, M; Zsak, G. Iron and Ferro Alloy Metals, non Ferrous Metals, Precious Metals, Industrial Minerals, Mineral Fuels. Austrian Federal Ministry of Sustainability and Tourism. [online] Available at: [www.en.bmwfw.gv.at/Energy/WorldMiningData/Seiten/default.aspx](http://www.en.bmwfw.gv.at/Energy/WorldMiningData/Seiten/default.aspx)

WITS (2019) World Integrated Trade Solution database. Data on Export, Import, Tariff, NTM. Available at: <https://wits.worldbank.org/> (Accessed: 17 October 2019).

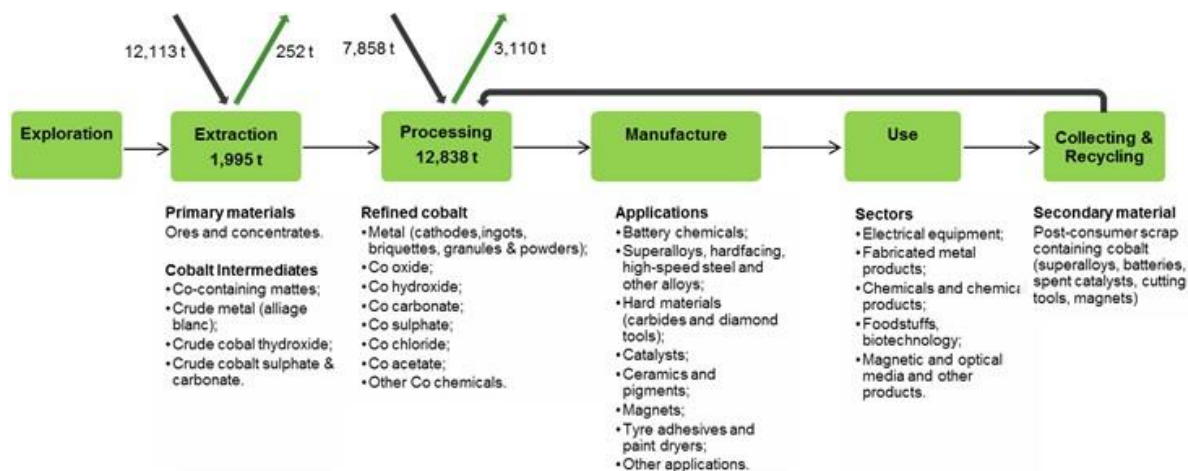
## **6.7 Acknowledgements**

---

The JRC prepared this factsheet. The authors would like to thank the Ad Hoc Working Group on Critical Raw Materials, in particular Ms. Aurela Shtiza and Ms. Francesca Girardi of IMA-Europe, as well as experts participating in SCRREEN workshops for their contribution and feedback.

# 7 COBALT

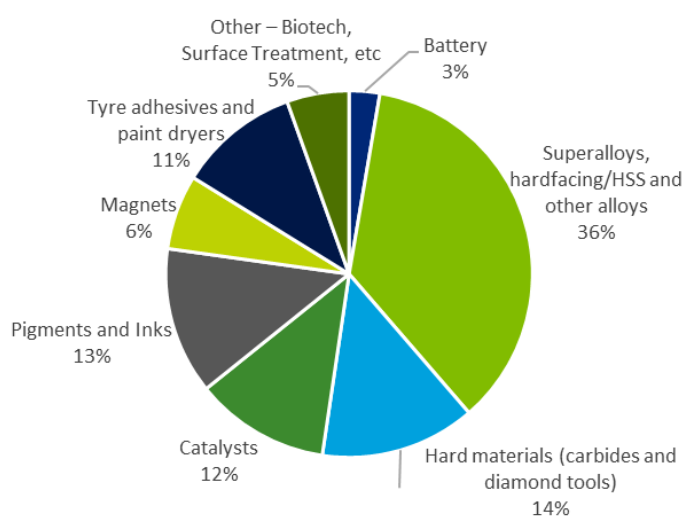
## 7.1 Overview



**Figure 85: Simplified value chain for cobalt**

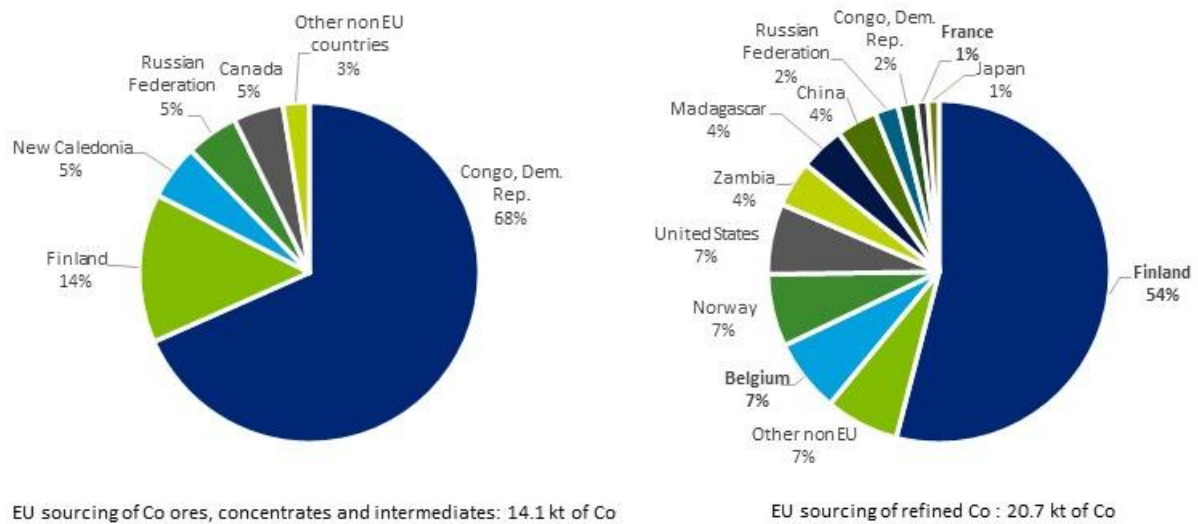
Cobalt (chemical symbol Co) is a transition metal appearing in the periodic table between iron and nickel. Cobalt is a shiny, silver-grey metal with many diverse applications due to its unique properties. It is a hard metal retaining its strength at high temperatures, has a high melting point, is ferromagnetic keeping its magnetic properties at the highest temperature of any other metal, is multivalent, produces intense blue colours, is able to form alloys with other metals imparting high-temperature strength and increased wear-resistance, is vital as a trace element in living organisms.

For this assessment, both cobalt extraction and processing are analysed. At mine stage, cobalt is assessed in the form of cobalt ores and concentrates, and at the processing stage in the form of refined cobalt. The intermediate cobalt products were considered as part of the cobalt ores and concentrates imports.



EU consumption of Co ores and concentrates and intermediates: 13.9 kt of Co: 18 603 tons  
 EU consumption of refined Co: 17.6 kt of Co

**Figure 86: End uses of cobalt in the EU, in Co content, in 2015. (Cobalt Institute 2019e)(Cobalt Institute 2019d)**



**Figure 87: EU sourcing of cobalt ores, concentrates and intermediates (left) and refined cobalt (right), between 2012 and 2016.**

The trade codes used in this assessment and the relevant assumptions are the following:

- For cobalt ores and concentrates: CN 26050000 “Cobalt ores and concentrates” considering a 10% of Co content;
- For cobalt intermediates:
  - CN 81052000 “Cobalt mattes and other intermediate products of cobalt metallurgy; unwrought cobalt; cobalt powders” assuming 17% of Co content if trade value is below 10 EUR/kg, and 60% if trade value is 10-20 EUR/kg,
  - CN 75011000 “Nickel mattes” assuming a specific Co content for each producer in the exporting country to the EU based on background information from (Roskill 2014);
- For refined Co:
  - CN 28220000 “Cobalt oxides and hydroxides” assuming 70% of Co content,
  - CN 28273930 “Cobalt chlorides”, considering 25% of Co content,
  - CN 81052000 “Cobalt mattes and other intermediate products of cobalt metallurgy; unwrought cobalt; cobalt powders” assuming 100% of Co content if trade value is higher than 20 EUR/kg,
  - CN 28332930 “Sulphates of cobalt and of titanium” assuming that cobalt products represent half of the flows, with a Co content of 20%.

Quantities are expressed in Co content, and all figures are averaged over the five years 2012–2016 data unless otherwise mentioned.

Global mine and refined production of Co has grown considerably over the last two decades at an annual rate of over 7%, underpinned by strong demand for cobalt in rechargeable batteries. Cobalt is mainly produced as a by-product from nickel and copper production. The extraction of cobalt is dependent on the extraction of copper and nickel. In 2018, cobalt production as a by-product of copper mines represented the 56% of the world total. 37% of the global cobalt supply was obtained as a by-product of nickel production. Only 7% was sourced from mining operations in which cobalt is the main commodity. The cobalt produced by these copper/nickel companies is traded internationally in the form of cobalt ores and concentrates, intermediate cobalt products and refined cobalt metal and chemicals. The Democratic Republic of the Congo (DRC) is the world’s dominant producer and exporter of cobalt ores and concentrates with a share of 97% of global exports in terms of value in 2017. Likewise, it is also the largest exporter of cobalt intermediates and refined cobalt globally by a significant share (58%) of total exports by value in 2017. Since the time period under review, the predominant exported products from the Democratic Republic of the Congo are intermediates containing cobalt, and only a relatively small

amount of cobalt contained in ores and concentrates is exported. China is the world's largest importer of both cobalt ores and concentrates (61% of total imports by value), and cobalt intermediates and refined cobalt (39% of total imports by value). Export taxes are applied by the Democratic Republic of the Congo to various cobalt raw materials.

The expansion of the electric vehicle market globally and in the EU should increase the demand for cobalt exponentially in the next decade, at an annual growth rate ranging from 7% to 13%. A market deficit is projected from 2025 onwards. At the same time supply disruptions are possible due to overconcentration of supply in the Democratic Republic of the Congo for mined cobalt and China for refined cobalt, slow development of new mining capacity, impact of copper and nickel demand, and unethical practices in artisanal mining in the Democratic Republic of the Congo.

Cobalt prices have been considerably volatile in the past, strongly affected by concerns over the supply and demand balance, but also by the prevailing political situation of the principal producer, the Democratic Republic of the Congo. While in March 2016 cobalt price was close to EUR 20,000 per tonne, it rose sharply to EUR 76,700 per tonne (+273%) within two years in March 2018 but returned to previous levels of about EUR 25,800 (-66%) per tonne in June 2019. The recent price rise was a consequence of market excitement regarding a possible cobalt shortfall resulting from the electrification of the automotive sector. However, this anticipation was obviously premature as the market is now (2019) in surplus.

The EU consumption of cobalt ores, concentrates and intermediates is 13,856 tonnes of contained cobalt (2,358 tonnes in ores and concentrates and 11,498 tonnes in Co intermediates and nickel mattes), the majority of which are sourced through imports from the DRC (68% of EU sourcing) and domestic production in Finland (14% of EU sourcing). The import reliance for cobalt ores, concentrates and intermediates is 86%.

The EU consumption of refined cobalt is 17,585 tonnes of cobalt content, which mainly originates from domestic production in Finland (54% of EU sourcing) and Belgium (7% of EU sourcing). The import reliance for refined cobalt is 27%.

Superalloys, which are used to make parts for gas turbine engines, are the major application for cobalt in the EU. They account for 36% of the cobalt consumed in the EU for manufacturing of finished products. Other applications for which cobalt is an essential raw material include carbides and diamond tools (14%), pigments and inks (13%), catalysts (12%), and tyre adhesives and paint dryers (11%). In the global context, the rechargeable battery market represents the largest and fastest-growing demand for cobalt; in 2016, rechargeable batteries consumed half of cobalt worldwide. Superalloys represent the second largest application for cobalt globally with a share of 18% of total global demand.

Substitution possibilities for cobalt are limited in many of its applications because of its remarkable properties. Substitution can be achieved in battery chemicals through other chemistries without cobalt based on nickel and manganese, or through content reduction in configurations with less cobalt loading. Due to loss of performance, functional cobalt substitution is severely restricted for superalloys and hard materials.

Cobalt is a crucial raw material for the implementation of the EU long-term strategy for the climate-neutral economy by 2050 as it is employed in the manufacture of rechargeable batteries for electric vehicles and energy storage systems.

Global resources of cobalt are estimated at approximately 25 million tonnes. The world's most important cobalt resources are located in the copper-cobalt deposits in the area commonly known as the central African Copper belt which spans across the Democratic Republic of the Congo and Zambia. In addition, vast resources of cobalt are identified in

manganese nodules and cobalt-rich crusts on the oceans' seafloor. World land-based reserves of cobalt are estimated at 6.9 million tonnes, with the majority situated in the Democratic Republic of Congo (49 %), Australia (17%) and Cuba (7%). Within Europe, resources of cobalt are known to exist in Finland, Sweden, Spain, Greece and Poland. Finland is the sole country with reported cobalt reserves complying with an international reporting system.

World mine production was nearly 134 kt as an average over 2012-2016. The Democratic Republic of Congo dominated global mine supply with 59% of the worldwide total. China (7%) was the second mine producer. In the EU, cobalt is mined as a by-product of nickel and copper mining in Finland. The annual domestic production amounted to almost 2 kt, but this represents approximately 1% of the yearly worldwide total.

World production of refined cobalt averaged to nearly 93 kt over 2012-2016. In contrast to mine output, China is the world's top producer of refined cobalt with almost half of the world total (49%), followed by Finland (12%) and Canada (6%). Domestic production in the EU is around 13 kt, with 87% of the total output produced in Finland. Cobalt is also produced in Belgium (11%) and France (2%). The total EU production of refined cobalt accounts for about 14% of the world total.

End-of-life products such as cobalt-bearing alloys, batteries and spent catalysts can be collected and recycled. The end-of-life recycling input rate in the EU was 19% in 2016 (Draft Co MSA 2019). The future potential for increased recycling of cobalt from EV batteries is particularly high. However, due to the lifespans of electric vehicle batteries, significant amounts of secondary cobalt will only become available for recycling in the near future (from 2025 onwards). The EU already holds sufficient relevant recycling infrastructure to treat the future end-of-life EV batteries.

Regarding socio-economic issues, these are mainly related to the situation in the Democratic Republic of Congo: poor governance, political instability, trade restrictions. Additionally, a varying amount of global cobalt supply originates from artisanal and small-scale mining (up to 20% of the global mine supply) raising concerns on human rights abuse. These are considered particular risks for the future security of supply.

Five cobalt salts (cobalt diacetate, cobalt dinitrate, cobalt carbonate, cobalt sulfate and cobalt carbonate) have been identified as substances of very high concern under the Regulation (EC) 2006/1997 and have been placed on the candidate list for authorisation. In December 2018, the European Chemicals Agency proposed restriction measures on the manufacture and use of these salts.

## **7.2 Market analysis, trade and prices**

---

### **7.2.1 Global market**

Cobalt demand is growing steadily in the last two decades, reflecting the increased use in superalloys and catalysts. Recently a huge rise in demand is observed for rechargeable Li-ion batteries. Initially, used in consumer electronics and ICT applications, and lately for electric vehicles and energy storage applications (Alves Dias *et al.*, 2018) (Roberts and Gunn 2014)(Roskill 2014).

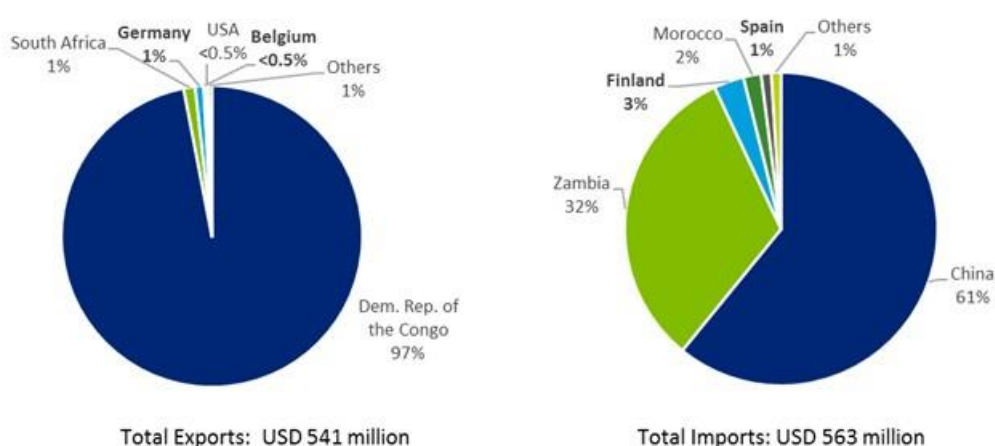
Since 1998, cobalt production is growing rapidly. The world mine production increased from around 32 kt in 1998 to more than 135 kt in 2017 at a compound annual rate of 7.6%. At the same time world production of refined cobalt increased from about 27 kt in 1998 to nearly 120 kt in 2017 at a compound annual rate of 7.8% (background data from (BGS 2019) and (WMD 2019). The increase in global mine production has been supplied mostly by DRC, which increased its share from 16%(1998) to 61%(2017) of the worldwide



production. In 2010 it even reached 69%. As concerns the refined output, the increase was driven mainly by China which enlarged its share from 5% in 1998 to more than 58% in 2017 (background data from (BGS 2019a)). The market value of the world production of refined cobalt in 2018 was estimated at EUR 7.7 billion<sup>53</sup>.

Cobalt is traded in numerous forms such as cathodes, powders, salts and chemicals and qualities (Al Barazi 2018). This variety reflects the numerous stages of the cobalt production chain and the fact that cobalt is mainly extracted as a by-product in nickel and copper mines which may have no capacity for refining produced cobalt. It is difficult to quantify the international trade in cobalt content, as it's considerable amounts are contained within nickel and copper ores and concentrates, mattes etc. of variant compositions (Roskill 2014). Moreover, aggregated HS codes of several cobalt commodities make it challenging to track global trade in terms of cobalt content, i.e. HS 810520 'Cobalt mattes and other intermediate products of cobalt metallurgy; unwrought cobalt; cobalt powders'.

Prior to refining, cobalt ores and concentrates are typically processed to intermediate products domestically to lower the high costs of shipping bulky ores/concentrates of lower value. Trade of ores and concentrates can take place due to corporate integration of mine operations and intermediate processing plants, or lack of domestic processing facilities (Roskill 2014). In 2017, the DRC was the dominant supplier of cobalt ores and concentrates with about 161 kt of exports in gross weight (HS 260500), accounting for 97% of the value of world exports. However, since 2012, only a relatively small amount of cobalt contained in ores and concentrates is exported. The DRC government is aiming at increasing domestic refining of copper and cobalt products and decreasing exports of ores and concentrates. Therefore, the predominant exported product is hydrometallurgical intermediate containing cobalt such as hydroxide. In addition, refinery producers have increasingly preferred to import partially processed intermediate products, as opposed to unprocessed concentrates (Roskill 2014). In 2017 China was the major destination country for world exports of cobalt ores and concentrates with a 61% share of the value of world imports, followed by Zambia (32%) and Finland (3%) (UN Comtrade 2019). Chinese companies have many life-of-mine contracts with African producers to supply their smelters, and much of the cobalt they refine is used domestically (Hannis and Bide 2009). Figure 88 shows the top world importers and exporters of cobalt ores and concentrates based on trade data for code HS 260500 'Cobalt ores and concentrates'.



<sup>53</sup> Estimation based on an average price of cobalt in 2018 of EUR 61,555 per tonne (LME cobalt cash) and the refined cobalt world production in 2018 of 124,344 tonnes (Cobalt Institute, 2019b)

**Figure 88: Top-5 cobalt exporting (left) and importing (right) countries in 2017 for cobalt ores and concentrates<sup>54</sup> by value. Background data from (UN Comtrade 2019)**

The international market of refined cobalt can be roughly split into metal products (e.g. cathodes, briquettes, ingots, granules, powder), and chemical products (e.g. cobalt chloride, oxide, hydroxide, and salts). For cobalt intermediates and refined cobalt, the DRC is the most significant exporter (58%) in terms of value, followed by China (12%) and Canada (9%). China is again the largest importer of refined cobalt (39%), followed by Zambia (12%), Japan (10%), US (10%) and South Korea (8%).

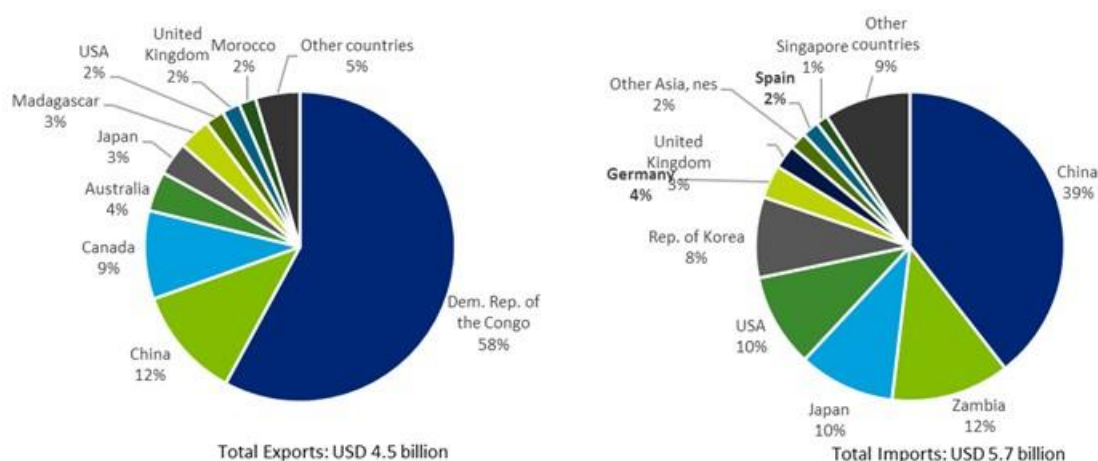
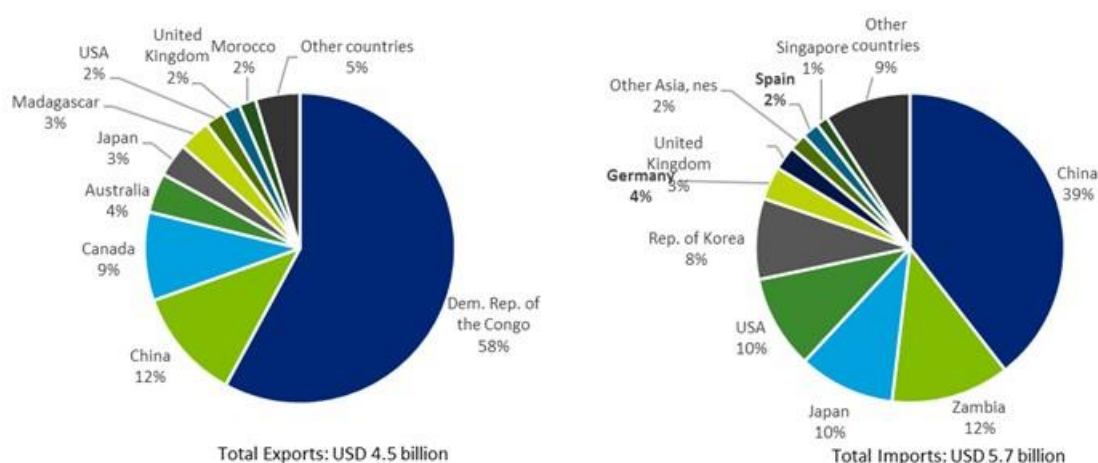


Figure 89 presents the top world importers and exporters of cobalt intermediates and refined Co by aggregating trade data for trade codes HS 282200 'Cobalt oxides and hydroxides', and HS 810520 'Cobalt mattes and other intermediate products of cobalt metallurgy; unwrought cobalt; cobalt powders'.



**Figure 89: Top-10 cobalt exporting (left) and importing (right) countries in 2017 for cobalt intermediates and refined cobalt<sup>55</sup> by value. Background data from (UN Comtrade 2019)**

<sup>54</sup> World trade of nickel or copper ores and concentrates containing cobalt may not be covered. In addition, as the DRC does not report exports of cobalt raw materials, the DRC export figures have been inferred from import statistics.

<sup>55</sup> World trade of nickel or copper intermediates containing cobalt may not be covered. In addition, as the DRC does not report exports of cobalt raw materials, export figures have been inferred from import statistics

Regarding export restrictions, the DRC, the world's top producer of cobalt, in 2017 applied export taxes (0.5% export tax and 1% export surtax) on *ad valorem* basis to cobalt ores and concentrates, cobalt oxides and hydroxides, cobalt mattes and other intermediate products of cobalt metallurgy, unwrought cobalt, and cobalt powders (OECD 2019). Also, in 2017 DRC introduced an export prohibition for copper and cobalt concentrates; however, a moratorium up to the final resolution of the country's energy deficit has been granted, as it is stated in the relevant legal act (R.D. Congo 2017). Among other restriction measures in the trade of cobalt raw materials in place in 2017 as reported by (OECD 2019), China imposes an *ad valorem* export tax to cobalt ores and concentrates and cobalt oxides and hydroxides of 15% and 10% respectively, and Zambia an 10% *ad valorem* export tax to cobalt ores and concentrates.

## 7.2.2 Outlook for supply and demand

Various studies have estimated the perspective of future cobalt demand. They are based on different scenarios on the global deployment of electric vehicles, the vehicle types comprising the fleet (e.g. plug-in hybrid electric vehicles (PHEVs), battery electric vehicles (BEVs)), the associated timing of market penetration, the mix of battery chemistries, and demand for batteries for domestic storage systems, and portable electronic devices

A recent JRC report (Patrícia Alves Dias et al. 2018) analysed the demand and supply of cobalt in the transition to electric mobility. It concluded that cobalt demand might experience a 3.7-fold increase between 2017 and 2030, driven by the expansion of the electric vehicles market and energy storage systems. The usage in Li-ion batteries will boost cobalt consumption, in particular in Nickel-Manganese-Cobalt (NMC) and Nickel-Cobalt-Aluminium (NCA) chemistries, both of which use cobalt as a cathode material (Patrícia Alves Dias et al. 2018).

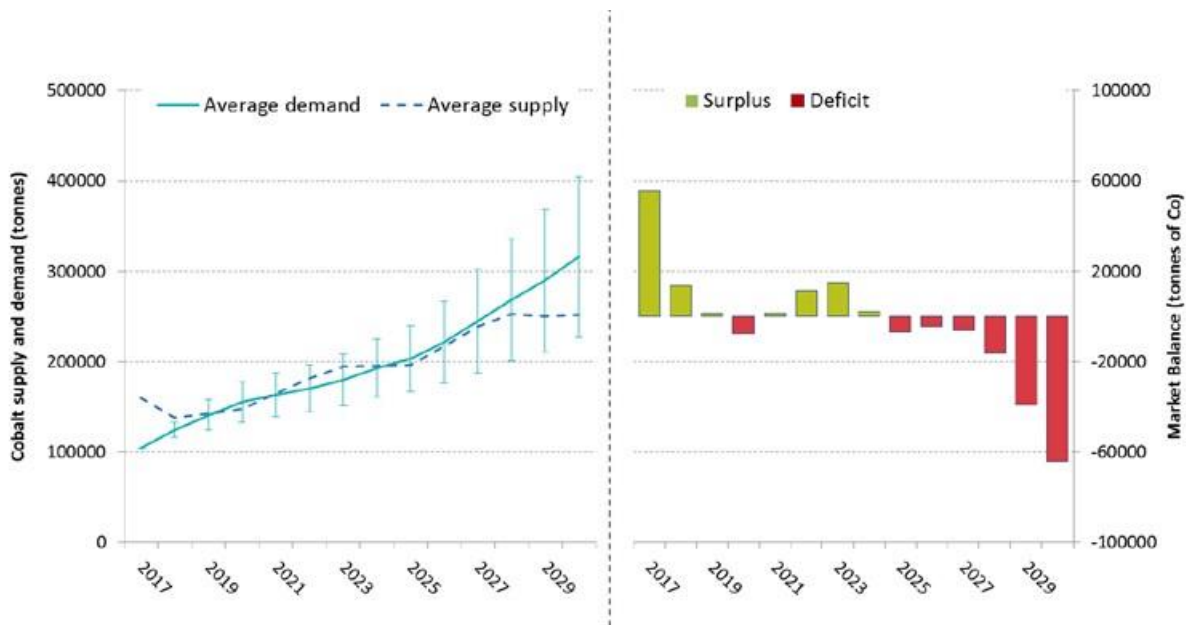
The latest (May 2019) outlook report published by the International Energy Agency (IEA) verifies the rapid increase of the global electric car fleet (in 2018 exceeded 5.1 million, up 2 million from 2017) (Bunsen et al. 2019). According to IEA's estimates, the annual cobalt demand for the batteries of EVs sold in 2018 was about 17 kt. In a scenario based on the announced policy ambitions<sup>56</sup> and assuming a mix of battery chemistries of 10% NCA, 40% NMC 622 and 50% NMC 811 for 2030, the study forecasts that the annual demand for cobalt for battery manufacturing will increase to around 170 kt in 2030, whereas in a scenario with higher EV uptake<sup>57</sup> the annual demand for cobalt in 2030 for EVs batteries will be more than twice as high, i.e. exceeding 350 kt per year.

On the supply side, the market is currently experiencing a surplus due to several expansions in mining capacity that have occurred in the last few years, mainly in the DRC. The JRC report projects that the global mining capacity of approximately 160 kt tonnes of cobalt in 2017, will reach between 193 and 237 kt tonnes in 2030 (Patrícia Alves Dias et al. 2018). However, while new mining projects, substitution and recycling can improve the stability of cobalt supply until 2030, worldwide demand is expected to consistently exceed supply from 2025 onwards (see Figure 90). The JRC report highlights various barriers and risks in relation to the structure of the cobalt supply which is highly prone to disruptions, e.g. overconcentration of supply in DRC for mined cobalt and China for refined cobalt, slow speed of developing new mining capacity from exploration to production, dependence on copper and nickel demand as cobalt is a by-product, and sourcing concerns due to unethical practices in artisanal mining in the DRC.

---

<sup>56</sup> Global EV sales reach 23 million and the stock exceeds 130 million vehicles in 2030.

<sup>57</sup> Scenario under the assumption that EVs will reach a 30% market share for all modes except two-wheelers by 2030. EV sales and stock nearly double by 2030 reaching 43 million and more than 250 million respectively.



**Figure 90: Average global supply-demand balances between 2017 and 2030 (Patrícia Alves Dias et al. 2018)**

According to (Ait Abderrahim and Monnet 2018), the EU cobalt demand for jet engines and batteries for EVs, for domestic use, smartphones and laptops will increase from 2 kt in 2015 to about 32 kt in 2035. 32 kt is higher by 2.5 times in comparison to the total EU cobalt consumption in 2012 for all applications. Electric vehicles and domestic energy storage will drive the growth of cobalt demand in the EU with expected use of 25.5 kt and 4 kt respectively by 2035.

The market forecast for world cobalt supply and demand is presented in Table 37.

**Table 37: Qualitative forecast of supply and demand of cobalt**

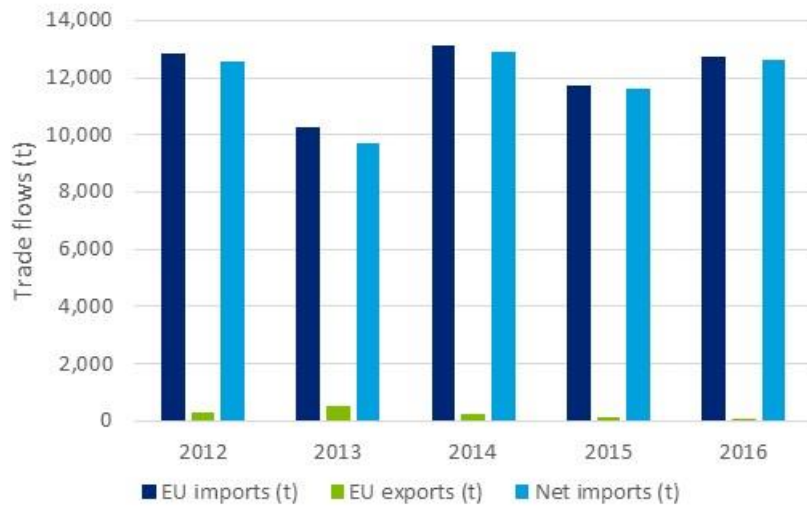
Material	Criticality of the material in 2020		Demand forecast			Supply forecast		
	Yes	No	5 years	10 years	20 years	5 years	10 years	20 years
Cobalt	x		+	+	+	+	+	?

### 7.2.3 EU trade

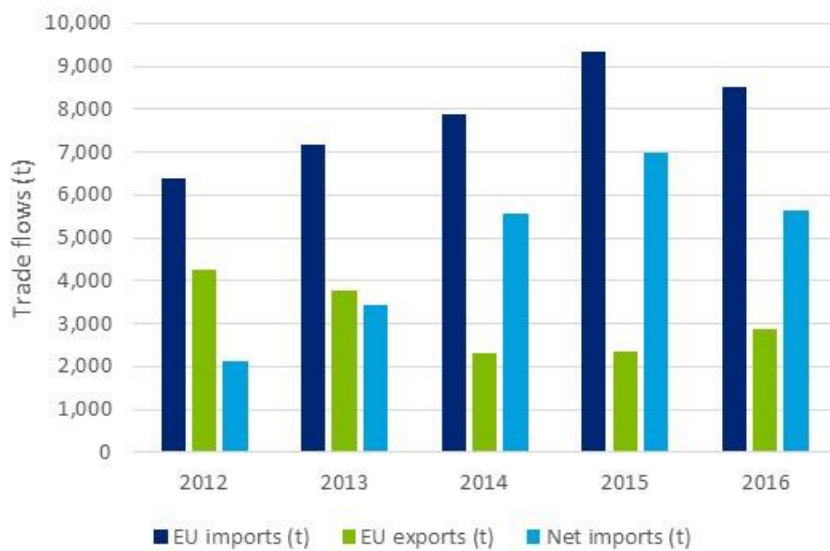
The average annual EU import in 2012-2016 was 12,113 tonnes of cobalt contained in ores and concentrates and cobalt intermediates. Imports of ores, concentrates and intermediates come mostly from the DRC (80%). Other countries of origin for EU imports are New Caledonia (6%), Russia (6%) and Canada (5%). On the other hand, EU imports of refined cobalt are less concentrated and have a wider distribution of sourcing countries (see Figure 93). In particular, the EU imported about 7,858 tonnes of refined cobalt, with Norway and the US the leading exporters (each 18%). Zambia (11%), Madagascar (11%) and China (10%) are included in the top EU suppliers for refined cobalt.

Figure 91 and Figure 92 illustrate the import and export flows of these materials to and from the EU collectively and demonstrate that the EU is a net importer of cobalt-bearing materials. The EU reliance on imports of cobalt ores, concentrates and intermediates is

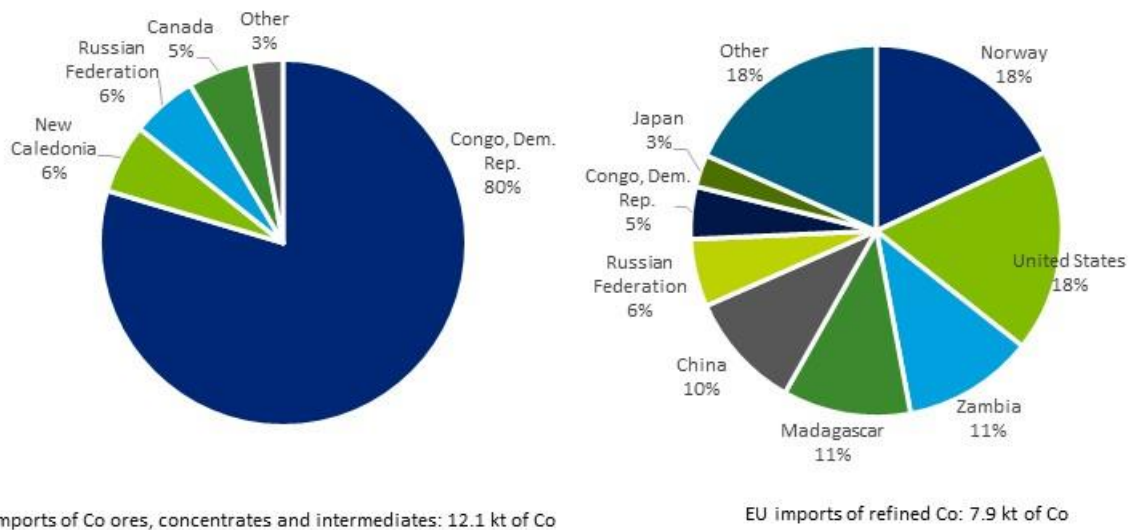
estimated at 86%, while the import reliance for refined cobalt amounts to 27%. Figure 93 shows the origin countries for the EU imports of cobalt.



**Figure 91: EU trade flows for cobalt ores, concentrates and intermediates (ESTAT Comext 2019)**



**Figure 92: EU trade flows for refined cobalt (ESTAT Comext 2019)**



**Figure 93: Countries of origin for EU imports of cobalt ores, concentrates and intermediates (left) and refined cobalt (right). Average 2012-2016. Background data from (ESTAT Comext 2019) (ULJAS 2019)**

As regards export restrictions applied by the leading EU suppliers, the DRC applies an export tax and export duty to cobalt ores and concentrates, as well as to refined cobalt products as it is described in Section 7.2.1 (OECD 2019).

Regarding trade agreements there is a EU-Canada Comprehensive Economic and Trade Agreement.

### 7.2.4 Prices and price volatility

Cobalt is mainly traded in the forms of cathode (cut and broken), metal powder, salts and chemicals. The price of many cobalt compounds is negotiated individually between producers, distributors and end users, depending on the product quality and the specifications required (Al Barazi 2018). Benchmark prices are assessed by price reporting agencies. Cobalt is also exchange-traded e.g. at the London Metal Exchange (LME).

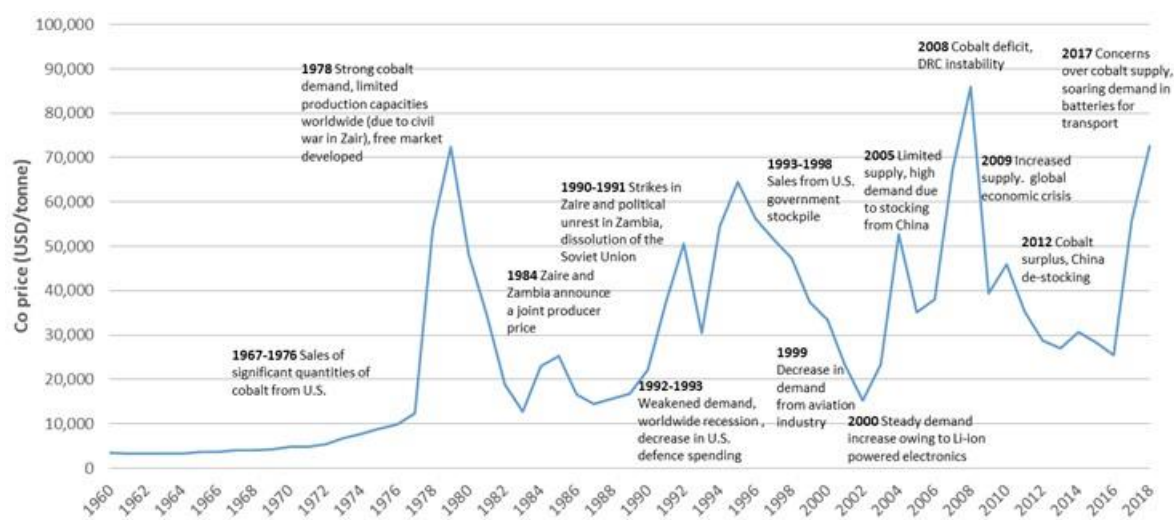
For many years, cobalt prices were only available from the Metal Bulletin free-market quotation, and this is still commonly used as a benchmark by the industry (European Commission 2017)(Fastmarkets 2019b). Cobalt spot prices reported by price reporting agencies refer to a variety of products and specifications. For example, prices provided by Fastmarkets MB include the free-market cobalt standard-grade (min 99.8% Co), cobalt sulphate (min 20.5% Co, China ex-works), the cobalt hydroxide index (min 30% Co, CIF China), cobalt tetroxide (min 72.6% Co, China delivered) etc. (Fastmarkets 2019a).

The LME began trading cobalt in 2010 in cash and futures contracts (Roberts and Gunn 2014). Until that time, cobalt was traded only on the free market (Hannis and Bide 2009)(Al Barazi 2018). The LME cobalt contract, which is physically settled, includes coarse-grained metal powder, briquettes, broken or cut cathodes, ingots, and rounds (LME 2019b). Cobalt traded on the LME in 2015 represented only 20% of global refined cobalt metal production and 9.5% of refined world production of cobalt metal and chemicals. This reveals that the LME cobalt contract is still in the early stage of acceptance as a primary pricing mechanism (USGS 2017). In January 2018, the minimum purity required for cobalt

metal delivery under the LME cobalt contract changed from 99.3% (low-grade) to 99.8%, or high-grade (Kusigerski 2018). In March 2019, the London Metal Exchange’s introduced a new cash-settled cobalt contract, which is settled against Fastmarkets’ MB benchmark standard-grade cobalt price (LME 2019b).

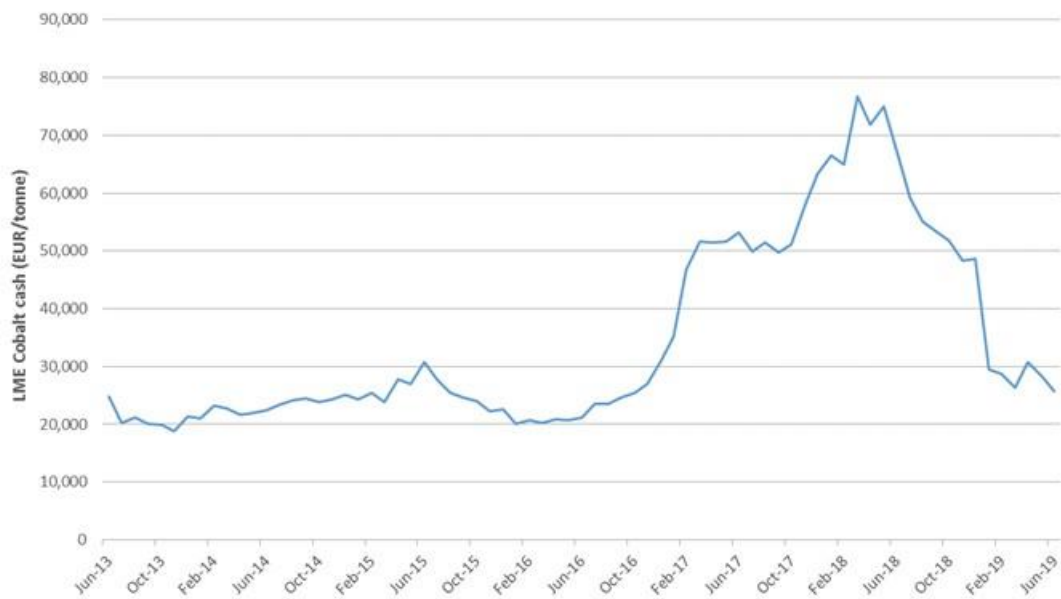
For historical perspective, cobalt prices became considerably volatile since the late 1970s (Al Barazi 2018). Various events which influenced cobalt prices may be noted in Figure 94, ranging from de-stocking, geopolitical unrest, recession and concerns over future supply (Patrícia Alves Dias et al. 2018). Since 2000, cobalt demand has risen gradually, driven from strong demand for rechargeable batteries used in portable electronic equipment (Patrícia Alves Dias et al. 2018). A significant price increase was seen over the 2002-2004 and 2006-2008 periods. This was due to a supply decrease, uncertainty over sufficient future supply and linked to a high level of global economic growth supported by strong Chinese demand (Al Barazi 2018). In 2002, the price of high-grade cobalt averaged just under USD 15,400 per tonne but increased to an average of over USD 86,000 per tonne by 2008 (see Figure 94). The rise in cobalt metal prices interrupted by the global economic crisis, causing prices to decrease dramatically between 2008 and 2009 as supply exceeded demand (Roskill 2014).

In 2017, a sharp increase of cobalt prices took place due to market expectations driven by an increase of demand for battery raw materials for EVs (DERA 2017)(DERA 2018). The price of cobalt in March 2016 was close to EUR 20,000 per tonne, and increased almost four times within two years to around EUR 76,700 per tonne in March 2018. (S&P Global Market Intelligence 2019b). Since then, cobalt prices dropped to around EUR 25,800 per tonne in June 2019 (S&P Global Market Intelligence 2019b). This was due to an oversupply of cobalt hydroxide from the DRC, limited stockpiling and consumer preference to cobalt hydroxide and cobalt salts rather than metal. (Fastmarkets 2019d) (Fastmarkets 2019c)(Roskill 2019a)(Reuters 2019);



**Figure 94. Annual average prices<sup>58</sup> of cobalt from 1960 to 2018 and significant events affecting cobalt prices. Background data from (USGS 2013) (USGS 2017a) (USGS 2018b) (DERA 2017a) (DERA 2018c) (Patrícia Alves Dias et al. 2018) (Roskill 2014) (European Commission 2014b)(Roberts and Gunn 2014)**

<sup>58</sup> Nominal prices not adjusted for inflation



**Figure 95. LME-cobalt cash from June 2013 to June 2019, monthly average (EUR/tonne). Data from (S&P Global Market Intelligence 2019b)**

Cobalt prices generally follow similar trends to those of nickel, except the period 2017-mid 2018 when cobalt prices surged. The constraints to the mineral supply of copper and nickel affect global cobalt output, such as the cobalt production decrease in 2016, mainly owing to lower production from nickel operations (Patrícia Alves Dias et al. 2018). Raise in cobalt prices, such as the one observed in 2017, can be expected when increasing cobalt demand is not associated with a growing demand for copper and nickel. (Al Barazi et al. 2018).

## 7.3 EU demand

### 7.3.1 EU consumption

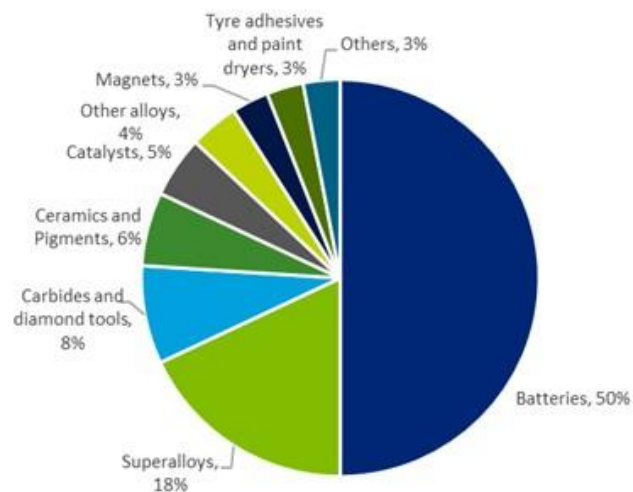
For cobalt ores, concentrates and intermediates the EU consumption is 13,856 tonnes per year in cobalt content, on average over the 2012–2016 period. Of this only 1,743 tonnes per year (averaged over 2012–2016) came from the EU (calculated as EU production – exports to non-EU countries). The remaining 12,113 tonnes were imported. The EU consumption consists of 2,358 tonnes of cobalt contained in ores and concentrates and 11,498 tonnes of cobalt contained in cobalt intermediates and nickel mattes. The net import reliance as a percentage of apparent consumption is 86% for cobalt ores, concentrates and intermediates.

The apparent consumption of refined cobalt in the EU amounts to 17,585 tonnes of cobalt content per year on average during 2012–2016. The amount of EU consumption covered by domestic production was 9,728 tonnes per year (again averaged over 2012–2016 and calculated as EU production – exports to non-EU countries). The remaining 7,857 tonnes were imported, resulting in net import reliance of 27% for refined cobalt.



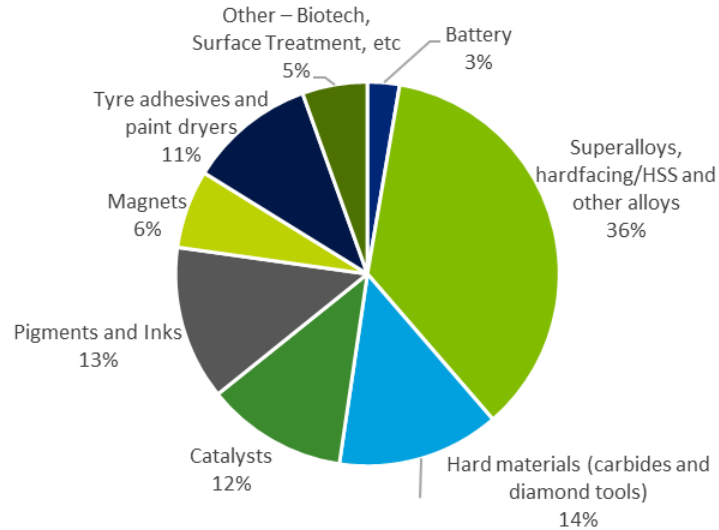
### 7.3.2 Uses and end-uses of cobalt in the EU

On a global scale cobalt is primarily used in manufacturing of battery chemicals (Ni-Cd, Ni-metal hydride and Li-ion rechargeable batteries used in portable electronic devices, energy storage systems and electric vehicles). In 2016 this was half of the worldwide consumption of cobalt. Other significant uses include superalloys mainly used in turbine engine components (18% of world consumption), and hard materials used in carbides for cutting tools (8%). Pigments used in colouring glass and ceramics and in paints (6%), catalysts for petroleum refining and plastics manufacturing (5%), magnets used in electric motors and loudspeakers (3%), tyre adhesives and paint dryers (3%), and a number of other minor end uses including foodstuffs, biotechnology, medicine, electroplating, electronics etc. make up the remaining one quarter of global consumption.



**Figure 96: Global end uses of cobalt in 2016. (Darton Commodities in (BRGM 2017))**

In the EU, the manufacturing of superalloys consumes 36% of the total demand for cobalt. Other applications for which cobalt is an essential raw material for the EU downstream industry are hard metals (cemented carbides and diamond tools) for metal tooling (14% of total demand), inks and pigments (13%), catalysts (12%), tyre adhesives and paint dryers (11%), magnet alloys (6%), battery chemicals (3%), and other uses (5%) (Cobalt Institute, 2019e) (Cobalt Institute, 2019d).



EU consumption of Co ores and concentrates and intermediates: 13.9 kt of Co: 18 603 tons  
 EU consumption of refined Co: 17.6 kt of Co

**Figure 97: EU end uses of cobalt<sup>59</sup> in 2016 (Cobalt Institute 2019e)(Cobalt Institute 2019d).**

The diverse uses of cobalt can be divided into two broad categories: metallurgical and chemical.

### 7.3.2.1 Metallurgical applications

Cobalt metal is required for the production of superalloys, hardfacing alloys and high-speed steels, magnet alloys, hard materials and special alloys.

Superalloys are alloys that have been developed specifically for high-temperature service, where a combination of high strength and resistance to surface degradation is required. Superalloys are employed in several critical applications such as jet engines, gas turbines, space vehicles, rockets, nuclear reactors, and power plants. Cobalt is used as the matrix or as an alloying element in superalloys because of the high melting point and superior corrosion resistance at high temperatures. Three alloy types can be distinguished under the definition of “superalloys”: cobalt, nickel, or iron-based alloys. Cobalt is mainly present in cobalt-based and nickel-based alloys, which account for 6% and 80% respectively of the superalloy production. Cobalt-based wrought alloys contain around 30% of cobalt, and cobalt-based casting alloys may contain up to 65% cobalt. Cobalt-based superalloys provide higher melting points than nickel (or iron) alloys, superior hot corrosion resistance to gas turbine atmospheres, and excellent thermal fatigue resistance and weldability over nickel superalloys. However, as the rupture strength of cobalt-based superalloys is lower at the interval of 815 °C to 1,100 °C temperatures than nickel-based alloys, they tend to be used for static (i.e. not rotating) applications. A high proportion of nickel-based superalloys, which have the majority share of the market, contain cobalt up to 20% by weight. Cobalt is not normally present in iron-based superalloys (Roskill 2014) (Cobalt Institute 2019c).

The term 'hardfacing' refers to hard alloys' deposition by a welding process on a base of softer metal to protect it from wear. Cobalt-based hardfacing alloys are selected for their excellent resistance to the broadest combination of wear types. Hardfacing alloys mainly contain cobalt, chromium, molybdenum and nickel in various compositions. The most frequently used hardfacing cobalt alloys typically contain 40% to 60% cobalt (i.e. Stellite alloys) (Roskill 2014).

<sup>59</sup> Cobalt demand for products manufactured in the EU

Cobalt is also an alloying element of high-speed steels (HSS) for the manufacture of cutting tools when high strength at elevated temperature is required. Cobalt is used in both traditional tool grades as well as in powder metallurgy grades at typical compositions ranging from 8% to 13% Cobalt (Roskill 2014).

The category 'hard materials' includes cemented carbide materials and diamond tools. Cobalt powder is employed as the binding material in the manufacture of cemented carbides to increase resistance to wear, hardness and toughness, essential qualities for cutting tools and wear-resistant components used by the metalworking, mining, oil drilling, and construction industries. The carbide is mainly produced from tungsten (Cobalt Institute 2019c). Similar to cemented carbides, cobalt is also used together with synthetic diamond in the manufacture of diamond tools such as grinding wheels and diamond saws, as the matrix that binds the wear-resistant particles together (Roskill 2014).

Since cobalt is ferromagnetic, it is used as an alloying metal in magnetic alloys for permanent magnets used in electrical equipment. Cobalt has the highest known Curie point of 1,121°C than any other metal, i.e. the temperature at which magnetic properties are lost. Cobalt is used either in the high-strength samarium-cobalt permanent magnets for electric motors or the lower-powered aluminium-nickel-cobalt magnets. Magnets containing cobalt are used in electric motors, generators, magnetic resonance imaging (MRI), microphones, loudspeakers, sensors, computer hard disk drives and many other applications (Hannis and Bide 2009) (Cobalt Institute 2019c). Furthermore, Co-bearing coatings may be applied to neodymium-iron-boron magnets for improved thermal stability and corrosion resistance (Cobalt Institute 2019c).

Other uses of cobalt in alloys include special alloys used for prosthetic limbs in orthopaedics due to excellent biocompatibility, wear-resistance and strength. Co-Cr and Co-Cr-Mo implants are mainly used, mostly in knee and hip operations and fracture repair (Cobalt Institute 2019c) (Roskill 2014).

### **7.3.2.2 Chemical applications**

In chemical applications, cobalt is used in the manufacture of various chemical compounds for a wide range of end-uses.

Cobalt is utilised mostly in rechargeable batteries. Cobalt substances used as chemical precursors for cathode materials are cobalt sulphate, dichloride and dinitrate (Cobalt Institute 2019d). Cobalt compounds for manufacturing active cathode materials are cobalt oxide, cobalt hydroxide, cobalt sulphate and cobalt metal of high purity. Cobalt is an essential constituent of lithium-ion batteries which compared to other battery types offer superior energy and power density as well as cycling ability. The lithium cobalt oxide (LCO) type, which has a cathode composed of  $\text{LiCoO}_2$  containing 60% of Co which accounts for 50% of the weight of the cathode, is used in portable electronic devices such as cell phones, tablets and laptops. Lithium-nickel-manganese-cobalt oxide (NMC) type, which has a cathode that contains 10-20 % cobalt, is used in electric vehicles and energy storage units (e.g. in renewable energy farms). Lithium-nickel-cobalt-aluminium oxide (NCA) batteries are used in EV applications as well as in industry and medical devices (Cobalt Institute 2019c). In recent years, Li-ion chemistries have shifted towards lower cobalt compositions (Mathieux et al. 2017) due to the high cobalt price. However, some cobalt is still necessary to maintain high performance, stability and safety (Cobalt Institute 2019d). Cobalt is also used in both anode and cathode of Ni-metal hydride batteries (NiMH batteries contain on average 4% of Cobalt) with applications in power tools and in hybrid electric vehicles, as well as in the cathode of Ni-Cd batteries (electrode contains on average 1 % of Co) (Cobalt Institute 2019c). The significant increase in the numbers of portable electronic devices, most of which contain lithium-ion batteries, has driven considerable growth in demand for cobalt in recent years. In 2005, battery chemicals represented just 25% of global end uses of cobalt (Mathieux et al. 2017), while in 2016 battery chemicals

for rechargeable accounted for 50% of total cobalt consumption. In 2020, a projected share of 60% is expected (Patrícia Alves Dias et al. 2018).

As cobalt is multivalent, it enhances the catalytic action; therefore, cobalt salts are used as precursors for industrial catalysts in the petrochemical and plastic industries. In particular, cobalt oxides are used in desulphurisation reactions in oil refining, in combination with molybdenum trioxide and aluminium oxide, which represents the highest tonnage of cobalt used in catalyst applications. Moreover, cobalt acetate is mixed with manganese bromide to be used as a catalyst in the synthesis of organic compounds, i.e. terephthalic acid (TPA) and di-methylterephthalate (DMT), which are precursors for the manufacture of PET. Cobalt is also used in hydroformylation reactions for the synthesis of alcohols for detergents, and aldehydes for the manufacture of plastics. Catalysts containing cobalt are also used in the production of synthetic diesel from natural gas. Cobalt compounds used in catalysts are cobalt metal, cobalt oxide, cobalt acetate, cobalt sulphate, cobalt chloride, cobalt hydroxide, cobalt carboxylates (Cobalt Institute 2019c)(Roberts and Gunn 2014).

One of the earliest known uses for cobalt is in pigments to produce an intense blue colour in glass, porcelain, ceramics, paints, inks and enamels. A variety of cobalt compounds, including cobalt oxides and other complex forms, can be used as colourants for a variety of blue-based tints. Cobalt can also be used as a decolouriser to suppress yellowish tint glass that originates from iron contamination. (Cobalt Institute 2019c)

Cobalt carboxylates are used in the production of adhesives that promote the bonding of the rubber to the steel bracing in steel-belted radial tyres (Roskill 2014). Cobalt carboxylates are also the principal cobalt compound used by the paint and ink industry to accelerate drying in inks, varnishes and oil-based paints (Cobalt Institute 2019c). The typical concentration of cobalt in ambient cure alkyd paint is around 0.06% (Roskill 2014).

Cobalt is a bio-essential trace element for bacteria, plants, animals and humans. It forms part of vitamin B12, which is of vital importance in the physiology of the human body, e.g. in red blood cell formation and neurological health. Humans have to obtain vitamin B12 from animal-derived foods. Only ruminant animals are able to synthesise vitamin B12 from elemental cobalt. As well as being essential for humans in the form of vitamin B12, cobalt is important for nitrogen fixation by free-living bacteria, blue-green algae and symbiotic systems. Cobalt underpins the biotechnology industry as it is an indispensable trace element for growth medium in fermentation processes which produce important biomolecules (e.g. therapeutic peptides, antigens, antibodies, single-cell proteins, vitamins, enzymes and antibiotics) utilised in many medical and pharmaceutical applications such as active pharmaceutical ingredients, diagnostic tools for analysis, production of antigens and antibodies etc. Finally, cobalt is also used in animal feeds as it is an essential nutrient for animals. Cobalt is added in trace quantities (typically between 1 and 5 ppm), mainly in the form of cobalt carbonate and cobalt sulphate, as a dietary supplement to animal feeds for ruminants (Cobalt Institute 2019c)(Roskill 2014).

A smaller market for cobalt chemicals, principally cobalt sulphate and dichloride, is electro and electroless-plating of cobalt and cobalt-alloy coatings to provide wear and corrosion resistance to the substrate (Roskill 2014). Other smaller applications include integrated circuits (contacts, metals leads and packages), semiconductors, magnetic recording media, and medical uses of cobalt isotopes ( $^{60}\text{Co}$ ,  $^{58}\text{Co}$ ,  $^{57}\text{Co}$ ,  $^{55}\text{Co}$ ) such as radiotherapy treatments, equipment sterilisation, brain imaging etc. (Cobalt Institute 2019c) (Roskill 2014).

Relevant industry sectors are described using the NACE sector codes in Table 38.

**Table 38: Cobalt applications, 2-digit and examples of associated 4-digit NACE sectors, and value-added per sector, Value-added average 2012-2016 (Eurostat 2019a)**

<b>Applications</b>	<b>2-digit NACE sector</b>	<b>Value-added of NACE2 sector (M€)</b>	<b>Examples of 4-digit NACE sector(s)</b>
Battery chemicals	C27 – Manufacture of electrical equipment	80,745	C2720 – Manufacture of batteries and accumulators
Superalloys, hardfacing, HSS, other alloys	C25 – Manufacture of fabricated metal products	148,351	C2511 – Manufacture of metal structures and parts of structures; C2550 Forging, pressing, stamping and roll-forming of metal, powder metallurgy; C2561 – Treatment and coating of metals; C2573 – Manufacture of tools; also possibly C3030 – Manufacture of air and spacecraft and related machinery
Hard materials (carbides, diamond tools)	C25 – Manufacture of fabricated metal products	148,351	C2573 – Manufacture of tools
Catalysts	C20 – Manufacture of chemicals and chemical products	105,514	C2013 – Manufacture of other inorganic basic chemicals; C2059 – Manufacture of other chemical products n.e.c.
Pigments and inks	C20 – Manufacture of chemicals and chemical products	105,514	C2012 – Manufacture of dyes and pigments
Magnets	C27 – Manufacture of electrical equipment	80,745	C2711 – Manufacture of electric motors, generators and transformers; C2790 – Manufacture of other electrical equipment; also possibly C2620 – Manufacture of computers and peripheral equipment; C2680 – Manufacture of magnetic and optical media
Tyre adhesives and paint dryers	C20 – Manufacture of chemicals and chemical products	105,514	C2030 – Manufacture of paints, varnishes and similar coatings, printing ink and mastics; C2052 – Manufacture of glues

### 7.3.3 Substitution

Substitutes for cobalt are continuously being researched mainly due to high price volatility, geopolitics of supply, cost and environmental benefits (Roberts and Gunn 2014). While in the majority of applications, the substitution of cobalt would result in lower product performance, there are a few examples where cobalt can be replaced in the production process. Nickel is the main substitute for cobalt in most applications (Patrícia Alves Dias et al. 2018). Substitution in the criticality assessment has been considered as follows:

**Batteries:** Substitution of cobalt in Li-ion cells is possible by nickel and manganese with adequate to good performance (Patrícia Alves Dias et al. 2018)(Tercero et al. 2018a), but with a potential compromise on thermal stability and safety (Cobalt Institute 2019d). In the criticality assessment, substitution in Li-ion batteries has been assessed through other chemistries, as well as through Co content reduction. There is a wide range of different

battery technologies available which could be considered as potential substitutes for the battery chemistries that contain cobalt. For example, the chemistries of  $\text{LiFePO}_4$  (LFP) and  $\text{LiMn}_2\text{O}_4$  (LMO) without cobalt can be used instead of  $\text{LiCoO}_2$  (LCO),  $\text{LiNiMnCoO}_2$  (NMC) and  $\text{LiNiCoAlO}_2$  (NCA) in Li-ion batteries. Also, amongst cobalt-bearing cathodes, several configurations with different cobalt contents are available (Patrícia Alves Dias et al. 2018).

The following battery chemistries have been examined in detail in the assessment: Lithium-nickel-manganese-cobalt-oxide (NMC) with reduction of Co content, Lithium-manganese-oxide (LMO), Lithium-iron-phosphate (LFP), Lithium-nickel-cobalt-aluminium-oxide (NCA) with a decrease of Co content, and NiCd/NiMH. In LMO and NiCd/NiMH potential substitutes, the performance is considered to be lower than for the battery chemistries that contain cobalt, whereas for NMC, LFP and NCA the performance is deemed to be similar. For all potential substitutes, the cost is assessed equal or lower relative to cobalt-based chemistries (Battery University 2018).

The cobalt contents of Li-ion batteries are expected to be reduced rather than eliminated in the future (USGS 2019) (Roskill 2019b). According to the latest report prepared by the Joint Research Centre, cobalt use in EV batteries can be reduced by 17% until 2025 and between 2025 and 2030 by another 12%, driven by substitution efforts towards more widespread use of NMC 622 and NMC 811 cathodes. Also, alternative, cobalt-free technologies are foreseen in the future (Patrícia Alves Dias et al. 2018).

Superalloys, Hardfacing, HSS and other alloys: Potential substitutes include composites (e.g. fibre-reinforced metal matrix composites, carbon-carbon and ceramic-ceramic composites), titanium-aluminides, nickel-based alloys, and iron-based superalloys. In some cases cobalt can be also substituted by niobium, rhenium, and PGMs in superalloys. All the above alternatives may replace to some extent cobalt-containing alloys used in applications such as jet aircraft engines, turbine blades for gas turbines, space vehicles or chemical equipment but with reduced overall performance e.g. loss of performance at high temperatures in some cases (Tercero et al. 2018)(Cobalt Institute 2018) (Harald Ulrik Sverdrup, Ragnarsdottir, and Koca 2017). Substitution of cobalt in turbine engine components by nickel has been evaluated from poor (Tercero et al. 2018) to adequate (Patrícia Alves Dias et al. 2018).

Hard materials: Materials such as nickel, nickel-aluminium, iron and iron-copper are potential substitutes for cobalt used as a metallic binder in cemented carbides for cutting tools, metal rollers and engine components. All of these possible substitutes result in a loss of product performance in the essential properties such as resistance to wear, hardness and toughness (Tercero et al. 2018).

Substitutes for other application categories were not considered in detail during the criticality assessment because their application shares were less than 10% of the total cobalt used. However, potential substitutes in other applications include:

Magnets: There is potential for substitution of cobalt-alloyed magnets by nickel-iron alloys, or, primarily, by neodymium-iron-boron alloys (Patrícia Alves Dias et al. 2018). Nd-Fe-B magnets have the highest energy density compared to other permanent magnets, making it the material of choice in high-performance applications where the size and weight are key requirements (Pavel et al. 2016). However, weaknesses are still present in high-temperature applications, which have been addressed by coating techniques with the addition of cobalt (Cobalt Institute 2019c). Other potential substitutes include barium or strontium ferrites (Patrícia Alves Dias et al. 2018) (USGS 2019).

Pigments: Substitution of cobalt in pigments is straightforward and alternatives with very good performance are available. Cerium, acetate, iron, lead, manganese, or vanadium can all be used as substitutes (Patrícia Alves Dias et al. 2018) (USGS 2019) (Harald Ulrik Sverdrup, Ragnarsdottir, and Koca 2017). However, in the automobile industry, issues of performance are reported in the use of cobalt-based pigments. Cobalt complex dyes have a high light-fastness which cannot be achieved by using alternative dyes resulting in colour fading. (European Commission 2017)

**Catalysts:** Cobalt may be substituted to some extent without significant performance loss. Ruthenium, molybdenum, nickel and tungsten can be used instead of cobalt, for instance in hydro-desulphurisation. An alternative ultrasonic process can also dispense with the use of cobalt, and rhodium can serve as a substitute for hydro-formylation catalysts (Patrícia Alves Dias et al. 2018). For chemical catalysts, platinum and palladium are also reported as potential substitutes for some of the used cobalt (Harald Ulrik Sverdrup, Ragnarsdottir, and Koca 2017). Ruthenium and iron are available substitutes for biodiesel production (Fischer–Tropsch process). Although cobalt catalysts provide the highest yield and longest life-time and they are preferred when the feedstock material is natural gas (R. L. Moss et al. 2011).

**Other Uses:** Copper-iron-manganese for curing unsaturated polyester resins and titanium-based alloys may be used as substitutes in prosthetics. (USGS 2019) Oxidised Zirconium is also considered a substitute for prosthetic hip implants. (Roskill 2014) There is no substitute for cobalt in biotechnology industry (European Commission 2017).

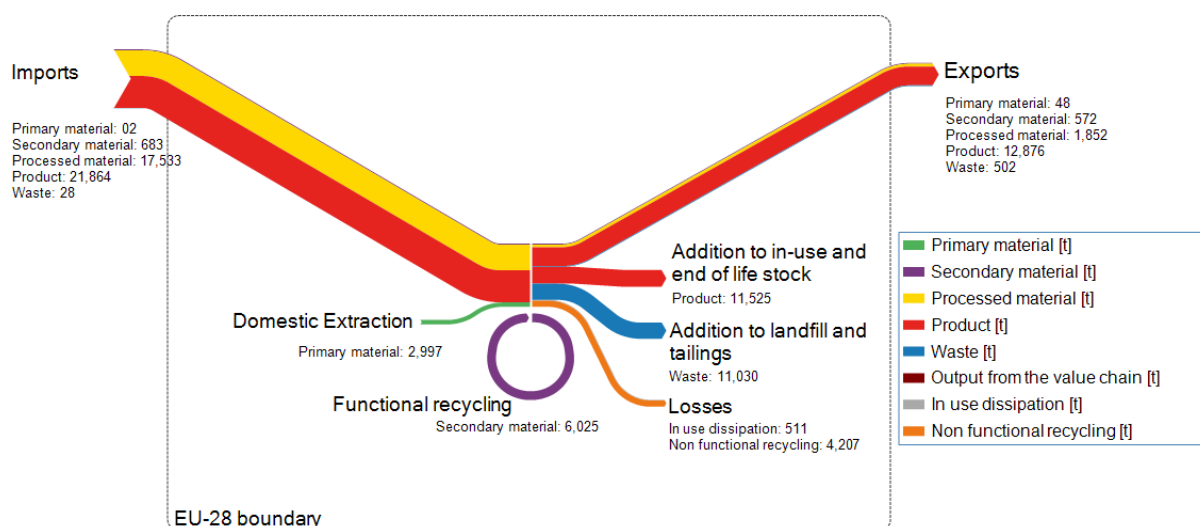
A study carried out by (Graedel et al. 2015) assessed cobalt’s substitutes performance as 54 on a scale from 0 to 100<sup>60</sup>.

## 7.4 Supply

### 7.4.1 EU supply chain

Despite domestic production of cobalt ores and refined cobalt, the EU remains dependent on imports, with an import reliance of 86% for cobalt ores, concentrates and intermediates, and 27% for refined cobalt.

The cobalt flows through the EU economy are demonstrated in the following Figure 98.



**Figure 98: Simplified MSA of cobalt flows in the EU, 2016. (Draft MSA of Cobalt 2019)**

#### 7.4.1.1 Cobalt mine supply

<sup>60</sup> On this scale, zero indicates that exemplary substitutes exist for all major uses and 100 indicates that no substitute with even adequate performance exists for any of the major uses.

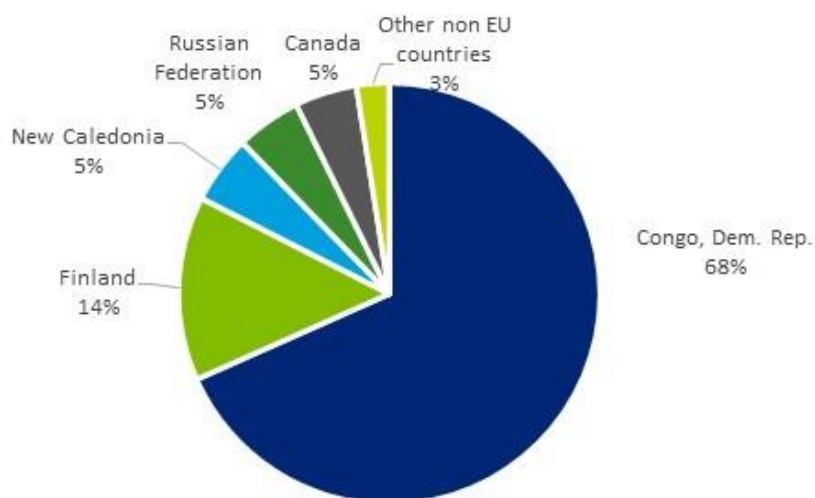
Cobalt is currently mined only in Finland in three mines as a by-product of nickel or copper (FODD 2017)(Gautneb et al. 2019). In particular:

- The open-pit Sotkamo (Talvivaara) mine operated by Terrafame. It is a large, low-grade black-shale hosted Zn-Ni-Cu-Co mine which produces cobalt as by-product to nickel and zinc. The mined nickel-rich polymetallic ore is processed in heaps by bioleaching under ambient pressure and temperature. Cobalt and other metals are precipitated as sulphide and marketed as intermediate nickel-cobalt sulphide. At full scale, cobalt production capacity is estimated at 1,800 tonnes per year (Patricia Alves Dias et al. 2018). Terrafame is constructing a new battery chemicals plant on-site that will change the current production target from 30 kt Ni-Co-sulphide to 170 kt of Ni-sulphate and 7,400 t of Co-sulphate. Commercial production is announced to commence at the start of 2021, and the end-use market of products will be manufacturing of batteries for electric vehicles (Terrafame Oy 2018) (TerraFame 2018a);
- The underground Kylylahti copper-zinc mine operated by Boliden Mining. The Kylylahti mine extracts from a small-sized Cu-Zn-Ni-Co deposit. Production started in 2012. The average annual production between 2012 and 2016 has been 1,000 tonnes of cobalt (GTK 2019b). In 2018, the mine produced 278 tonnes of Cobalt (Gautneb et al. 2019);
- The open-pit Kevitsa nickel-copper mine also operated by Boliden Mining. The Kevitsa mine exploits a large low-grade Ni-Cu-PGE deposit. Production started in 2012, and averaged to 370 tonnes of cobalt per year over the 2012-2016 period (GTK 2019a). In 2018, the mine produced 591 tonnes of cobalt (Gautneb et al. 2019).

The Hitura mine in Finland producing cobalt in nickel-copper concentrates suspended production in 2013 (FODD 2017), and the Aguablanca mine in Spain producing Ni-Cu concentrates containing cobalt closed in 2016 (USGS 2017). In Greece and Poland, cobalt is extracted in operating mines of lateritic nickel and copper ores, respectively, but it is not recovered as a by-product (Lauri et al. 2018). The H2020 project METGROW+ (2016-2020) is currently studying the extraction of cobalt from Polish and Greek low-grade Ni-bearing laterites by innovative metallurgical technologies (Mäkinen et al. 2018).

On a global scale, EU mine production is small (nearly 2,000 tonnes per year) representing a share of only 1.5% of the total. New Caledonia (French overseas territory) produces circa 4,000 tonnes annually, covering 4% of the world total mine production.

Figure 99 presents the EU sourcing (domestic production and imports) for cobalt ores and concentrates and cobalt intermediates based on averages over the period 2012–2016. The amount of imported cobalt contained within ores and concentrates is about 400 tonnes and 11,700 tonnes for intermediates.



EU sourcing of Co ores, concentrates and intermediates: 14.1 kt of Co



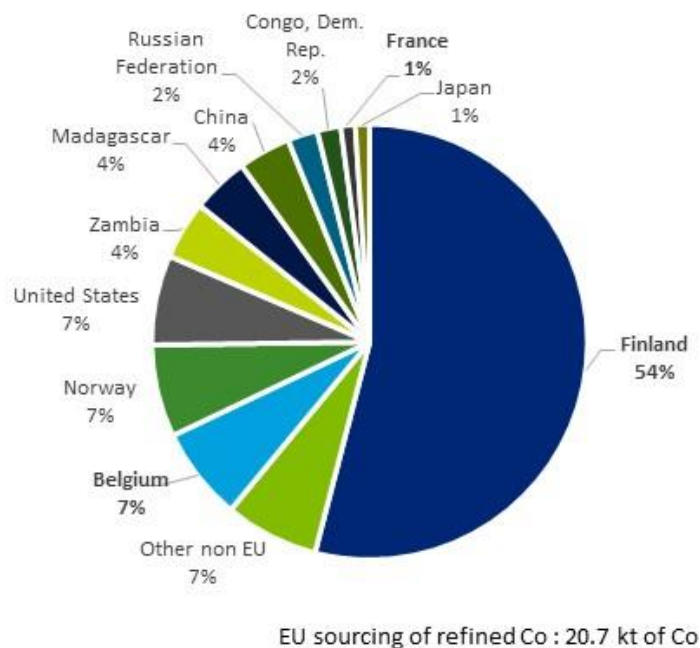
**Figure 99: EU sourcing of cobalt ores, concentrates and intermediates. Average 2012-2016 (Eurostat 2019), (ULJAS, 2019), (WMD, 2019).**

#### **7.4.1.2 Intermediates and refined Co supply**

The EU is an important producer of refined cobalt accounting for almost 14% of the world's production. Intermediates and refined cobalt are currently produced in:

- The Kokkola cobalt refinery in Finland, operated by Freeport Cobalt. It produces metal powders and a wide range of cobalt chemicals (i.e. acetate, carbonate, hydroxide, oxide, sulphate) for chemical, pigment, and powder metallurgy applications. It also produces battery-grade cobalt compounds used as precursors for cobalt-based cathode materials. According to production data published by the Cobalt Institute, the average annual production has been about 10,300 tonnes over 2012-2016, while in 2018 production reached 12,874 tonnes (Cobalt Institute 2019b). The yearly capacity is reported to be 15,000 tonnes of cobalt (USGS 2018). The refinery mainly processed intermediate hydroxide and alliage blanc imported from the Democratic Republic of the Congo, as well as intermediates from Harjavalta plant in Finland (Roskill 2014) (USGS 2017). According to the company, more than 50% of the total feed is secondary material from residues and by-products (Freeport Cobalt 2019);
- The Harjavalta nickel refinery in Finland, operated by Norilsk Nickel, produces cobalt intermediates in the form of cobalt sulphate and cobalt solutions. The refinery processes various nickel-bearing materials sourced from Norilsk's operations in Russia and third parties, e.g. Ni-Co mattes and nickel concentrates (Roskill 2014) (Nornnickel 2018). According to Roskill, the capacity is 380 tonnes of cobalt in the form of cobalt sulphate (Roskill 2014);
- Umicore operates the Olen refinery in Belgium which produces refined cobalt in various forms such as metal powder, cobalt salts (cobalt carbonate, cobalt sulphate, cobalt chloride, etc.) and cobalt oxide. Various cobalt materials, such as cobalt residues and other cobalt-containing materials, are processed into a wide range of refined cobalt products (USGS 2018) (Roskill 2014). Refined cobalt capacity is reported as 1,500 tonnes per year (USGS 2018);
- In France, Eramet produces cobalt chloride at the Sandouville nickel refinery, as a by-product of refining nickel matte imported from New Caledonia. From mid-2017 the refinery is supplied with nickel matte by a new European source. (Eramet 2019) Capacity is reported to be 500 tonnes of cobalt (USGS 2018).

Figure 100 presents the EU sourcing (domestic production and imports) for intermediate and refined cobalt as an average over the period 2012–2016. EU production of refined Co was nearly 13 kt per year, and imports were approximately 7 900 tonnes per year of cobalt oxides and hydroxides, cobalt sulphates, and cobalt chlorides.



**Figure 100: EU sourcing of refined cobalt. Average 2012-2016 (Eurostat 2019), (ULJAS, 2019), (WMD, 2019).**

#### 7.4.1.3 Supply of recycled cobalt

In the Freeport Cobalt refinery in Kokkola in Finland, more than 50% of the total feed is material from secondary sources (e.g. cobalt contained in residues and by-products) according to company's statement (Freeport Cobalt 2019). The plant applies hydrometallurgical processes, which can extract and purify cobalt to obtain high-quality chemicals (Sundqvist Ökvist et al. 2018).

Hydrometal in Engis, Belgium, processes cobalt-containing wastes from by-products of zinc metallurgy. The input material consists of cement coming from zinc electrolysis, which typically contains 5-7% cobalt, and by adequate processing, cobalt concentrates are obtained with a Co content of over 65%, which are sold to cobalt refineries (Sundqvist Ökvist et al. 2018).

Nickelhütte Aue GmbH in Germany processes secondary materials such as electroplating sludges and residues from non-ferrous metal processing. Currently, around 50 tonnes of cobalt is recovered annually in the form of cobalt chemicals (Al Barazi 2018).

Cobalt is also recovered from batteries by several recyclers and through different processes (Mathieux et al. 2017). Data on the quantities recovered from batteries are not available. Cobalt is recovered in the following operating battery recycling plants in the EU:

- In *Umicore's* plant in Belgium (Hoboken), a patented process is applied that combines a pyro-metallurgical treatment and a hydro-metallurgical process to recycle spent rechargeable batteries. Previously separated NiMH and Li-ion batteries are smelted with an ultra-high temperature plasma torch. The obtained alloy containing cobalt and nickel is further refined by a downstream hydrometallurgical process to produce  $\text{CoCl}_2$ . The plant has a combined capacity of 7,000 tonnes of treating Li-ion and NiMH batteries (Patrícia Alves Dias et al. 2018)(Sundqvist Ökvist et al. 2018);
- *Akkuser* in Finland (Nivala) recovers cobalt from Li-ion batteries (Roskill 2019b). The company treats annually 1,000 tonnes of Li-ion batteries (Lebedeva, Di Persio, and Boon-Brett 2017);

- *Accurec* in Germany (Krefeld) recycles annually 1,500-2,000 tonnes of Li-ion batteries. Cobalt is recovered by a combination of pyrolysis and hydrometallurgical treatment of the slag (Lebedeva, Di Persio, and Boon-Brett 2017) (Kushnir 2015);
- In *Recupyl's* plant in France (Grenoble), cobalt is reported to be recovered from spent Li-ion batteries by hydrometallurgical treatment (Kushnir 2015). Capacity is 110 tonnes of Li-ion batteries per year (Lebedeva, Di Persio, and Boon-Brett 2017);
- *SNAM* in France recovers cobalt by a combination of pyro-, mechanical and hydrometallurgical treatment. Total capacity is 300 tonnes of various types of batteries (Lebedeva, Di Persio, and Boon-Brett 2017).

According to (Patrícia Alves Dias et al. 2018), the current recycling infrastructure in the EU should enable the recycling of around 160,000 units of used batteries from EVs. This is well above the forecasted amount of batteries available for recycling in the EU until 2025. Estimates show that around 500 tonnes of recycled cobalt from EV batteries deployed in the EU should be available in 2025, and may amount, to 5,500 tonnes of recycled cobalt in 2030, accounting for around 10% of European cobalt consumption in the EVs sector. The existing large recycling capacity in the EU is likely to expand in the future and attract significant volumes from abroad (Patrícia Alves Dias et al. 2018).

## 7.4.2 Supply from primary materials

### 7.4.2.1 Geology, resources and reserves of cobalt

**Geological occurrence:** Cobalt has a relatively low abundance in the Earth's crust. Estimates of the crustal abundance vary between 15 and 30 parts per million (Roberts and Gunn 2014). For example, (Al Barazi 2018) reports the average cobalt content in the earth's crust as 25 ppm and (Rudnick and Gao 2014) about 27 ppm. According to (Rudnick and Gao 2014) the abundance of cobalt in the upper crust is around 17 ppm. Cobalt is not found as a pure metal in nature but in conjunction with other elements (mainly Fe, Ni, Cu and S), which are usually predominant. Among common cobalt-bearing minerals are sulphides and sulpharsenides such as cobaltite (CoAsS), carrollite (Cu(Co,Ni)<sub>2</sub>S<sub>4</sub>), erythrite (Co<sub>3</sub>(AsO<sub>4</sub>)<sub>2</sub>·8H<sub>2</sub>O) and skutterudite ((Co,Ni)As<sub>3-x</sub>).

Cobalt is a minor constituent in a number of ore types in various geological settings. The main ore types in which cobalt minerals can be found in economic concentrations are the following (Slack, Kimball, and Shedd 2017) (Roberts and Gunn 2014) (Hannis and Bide 2009):

- *Stratiform sediment-hosted deposits of Cu-Co sulphides and oxides*, typically exploited for copper. The most significant deposits are situated in the Central African Copperbelt which extends for 500 kilometres across north-western Zambia and south-eastern parts of the Democratic Republic of Congo. Typical grades of the cobalt sulphide minerals are between 0.1 and 0.4% Co, which are the highest among the different geological settings in which cobalt is occurring;
- *Magmatic deposits of Ni-Cu (-Co-PGE) sulphides*, primarily worked for nickel, copper and platinum group metals (PGMs). Significant deposits of this type include the Norilsk deposit in Russia, the Sudbury deposit in Canada, and the Kambalda deposit in Western Australia, all of which are primarily worked for nickel. Ore grade averages to 0.1% Co;
- *Lateritic Ni-Co deposits* mainly worked for nickel. Significant examples are found in New Caledonia and Cuba. Typical ore grades in these deposits range from 0.05% to 0.15% Co;
- *Hydrothermal and volcanogenic deposits*. Cobalt is a by- or co-product of mining polymetallic ores. Such deposits occur in Finland, Sweden, Norway, USA, Canada and Australia. The Bou Azzer deposit in Morocco, where cobalt is currently extracted as the main product, also falls within this category. A typical ore grade is 0.1% Co.

Significant potential resources of cobalt occur on the seafloor within polymetallic nodules (or 'ferromanganese nodules') and cobalt-rich polymetallic crusts (or 'ferromanganese crusts'). Both settings are enriched in many rare and critical metals with significant concentrations. The Fe-Mn nodules lie mainly on abyssal plains at water depths of 3,500-6,500 m (Slack, Kimball, and Shedd 2017). The highest concentrations occur in the Pacific Ocean, in the Clarion-Clipperton Zone, which extends from off the west coast of Mexico to as far west as Hawaii where the quantity of Fe-Mn nodules is estimated at 21.1 billion tonnes and the mean content of cobalt in the nodules at 0.2% by weight (Ecorys 2014). Co-rich ferromanganese crusts occur at relatively shallow depths of 800 to 3,000 m (Slack, Kimball, and Shedd 2017). A rough estimate of the quantity of crusts in the central Pacific region is about 7.5 billion tonnes. In Co-rich crusts, cobalt commonly shows values greater than 0.5% by weight (Ecorys 2014). Legal, economic, and technological barriers have prevented so far exploitation, but advances in technology may allow the production of these resources to be economically viable (Slack, Kimball, and Shedd 2017) (Roberts and Gunn 2014). Additional investigation and exploration would be necessary to estimate these marine resources, given that the interest in seabed exploration fluctuates depending on market conditions (i.e. metal price hikes) (European Commission 2019b). According to (Harald Ulrik Sverdrup, Ragnarsdottir, and Koca 2017), ocean mining contribution to global cobalt supply is not foreseen before 2050.

In Europe, most of the known cobalt-bearing deposits and occurrences are clustered in the Nordic countries (Finland, Sweden and Norway). Deposits are more scattered throughout South and Central Europe (Gautneb et al. 2019). The GeoERA project MINDeSEA has identified that most of the cobalt occurrences and deposits in ferromanganese crusts and polymetallic nodules in the seabed are concentrated in Spanish and Portuguese waters (European Commission 2019b).

**Global resources and reserves**<sup>61</sup>: The United States Geological Survey estimates cobalt global resources to be approximately 25 million tonnes. The largest are located in the sediment-hosted copper-cobalt deposits in the Democratic Republic of the Congo and Zambia. Significant cobalt resources also exist in nickel-bearing laterite deposits in Australia, nearby island countries and Cuba. Magmatic nickel-copper sulphide deposits are located in Australia, Canada, Russia and the US. Cobalt resources occurring in manganese nodules and cobalt-rich crusts on the seafloor are estimated to be more than 120 million tonnes (USGS 2019).

World reserves of cobalt are estimated at around 6.9 million tonnes of contained cobalt (USGS 2019). The Democratic Republic of the Congo has the largest global cobalt reserves (49%), followed by Australia (17%) and Cuba (7%). Global reserves of cobalt are shown in Table 39.

---

<sup>61</sup> There is no single source of comprehensive evaluations for resources and reserves that apply the same criteria to deposits of cobalt in different geographic areas of the EU or globally. The USGS collects information about the quantity and quality of mineral resources but does not directly measure reserves, and companies or governments do not directly report reserves to the USGS. Individual companies may publish regular mineral resource and reserve reports, but reporting is done using a variety of systems of reporting depending on the location of their operation, their corporate identity and stock market requirements. Translations between national reporting codes are possible by application of the CRIRSCO template, which is also consistent with the United Nations Framework Classification (UNFC) system. However, reserve and resource data are changing continuously as exploration and mining proceed and are thus influenced by market conditions and should be followed continuously.

**Table 39: Global reserves of cobalt in 2018. Data from (USGS 2019)**

Country	Estimated cobalt reserves (kt of Co content)	Percentage of the total (%)
Democratic Republic of the Congo	3,400	49%
Australia <sup>62</sup>	1,200	17%
Cuba	500	7%
Philippines	280	4%
Russian Federation	250	4%
Canada	250	4%
Madagascar	140	2%
China	80	1%
Papua New Guinea	56	<1%
United States of America	38	<1%
South Africa	24	<1%
Morocco	17	<1%
Other countries (unspecified)	640	9%
World total (rounded)	6,900	

S&P (S&P Global Market Intelligence 2019a) estimates that nearly three-quarters (72%) of the cobalt resources and 59% of the cobalt reserves are held by primary copper producers. Nickel is the primary product in operating mines controlling 25% of resources and 38% of reserves of cobalt currently exploited. Only 3% of resources and 3% of reserves are owned by companies for which cobalt is their primary product.

**EU resources and reserves:** The largest cobalt resource in Europe is located at the Sotkamo (Talvivaara) polymetallic Ni-Cu-Zn-Co sulphide deposit in Finland. Other significant deposits in Finland, by tonnes of contained cobalt, include the Kevitsa Ni-Cu-PGE, the Kylylahti Cu-Zn, the Sakatti Ni-Cu-PGE, the Hautalampi Ni-Cu-Co and the Juomasuo Au-Co deposits. In Greece, reserves reported for the lateritic nickel deposits include almost 50,000 tonnes of cobalt and mineral resources comprise additional 79,000 tonnes of cobalt. Ore reserves listed for Poland contain 75,000 tonnes of cobalt and additional 7,300 tonnes of resources but are poorly documented, whereas, in Sweden, total resources amount to about 20,000 tonnes of cobalt. Resources of cobalt are also known to exist in Spain (Lauri et al. 2018) (FODD 2017) (S&P Global Market Intelligence 2019a). Table 40 and Table 41 present cobalt resources and reserves data respectively, sourced from the Fennoscandian Mineral Deposits database and corporate reports.

**Table 40: Cobalt resources data in the EU**

Country	Classification	Quantity (Mt of ore)	Grade (% Co)	Reporting code	Reporting date	Source
Finland	Total resource	78.7	0.003	JORC	12/2017	(FODD 2017) <sup>63</sup>
	Total resource	46.8	0.006	NI43-101	12/2017	
	Historic resource estimate	35.6	0.010	None	12/2017	
	Total resource	1,525	0.017	JORC	06/2018	(FODD 2017)

<sup>62</sup> Joint Ore Reserves Committee (JORC)-compliant reserves were about 390,000 tonnes

<sup>63</sup> The compilation refers to medium and large deposits only

						(Terrafame 2018b) <sup>64</sup>
	Measured	26.1	0.022	PERC	12/2018	(Boliden 2019b) (Boliden 2019c) <sup>65</sup>
	Indicated	118.6	0.013		12/2018	
	Inferred	19.9	0.011		12/2018	
Sweden	Total resource	366.4	0.003	NI43-101	12/2017	(FODD 2017)
	Historic resource estimate	52	0.015	None	12/2017	(FODD 2017)

**Table 41: Cobalt reserves data in the EU**

Country	Classification	Quantity (Mt of ore)	Grade (%Co)	Co content (t)	Reporting code	Reporting date	Source
Finland	Proven	63.3	0.012	7,850	PERC	12/2018	(Boliden 2019b) (Boliden 2019c) <sup>66</sup>
	Probable	66.6	0.011	7,250			

#### 7.4.2.2 Exploration and new mine development projects in the EU

Exploration projects targeting cobalt among other metals in polymetallic deposits were (2019) ongoing across the EU, mainly in Finland and Sweden, but also in Slovakia, Germany, Spain, Cyprus, Austria, Poland, and Czechia (S&P Global Market Intelligence 2019a). The more advanced projects are situated in Sweden, in which, cobalt is a companion metal of the main commodities, e.g. the Haggan vanadium project, and the Ronnbacken nickel project at prefeasibility/scoping stage.

#### 7.4.2.3 Cobalt mining

Cobalt is mostly extracted as a by-product of copper and nickel mining. Data<sup>67</sup> from 2017 shows that 56% of world cobalt primary supply comes from copper mines and 37% from nickel mines (S&P Global Market Intelligence 2019b). Only 7% of the global cobalt supply is sourced from mining operations where cobalt is the main product. This takes place for example at the Bou Azzar mine in Morocco and the Lubumbashi project processing slags in DRC. The ratio between copper and nickel mining as the source of cobalt is variable as it depends on the demand and associated production of copper and nickel (Al Barazi 2018).

Cobalt extraction from the ores as a by-product depends on the grade, economic feasibility and the process routes followed by individual operations (Roskill 2014). Mining of cobalt deposits is done by conventional underground and open-pit methods. Open-pit mining is the predominant method for weathered copper-cobalt deposits in DRC and Zambia (Roberts and Gunn 2014).

Specific techniques for beneficiation depend on two factors. One is the type and individual composition of the treated ore. The second one is the subsequent processes required to extract copper or nickel. Ore processing involves crushing, grinding and separating the metal-bearing material from gangue using either physical or chemical techniques as

<sup>64</sup> Talvivaara active mine. The average grade is sourced from (FODD, 2017)

<sup>65</sup> Kevitsa and Kylylahti active mines

<sup>66</sup> Kevitsa and Kylylahti active mines. Mineral reserves for the Talvivaara mine are not available

<sup>67</sup> Artisanal and small-scale mining of the mineral heterogenite in DRC is not included.

appropriate. Nickel laterite ores are usually refined directly, i.e. only after upgraded by crushing and grinding. Most other cobalt-bearing ores are first concentrated, either by flotation or gravimetric methods (Roberts and Gunn 2014). Products from copper mines are cobalt concentrates and Co-Cu-concentrates, and from nickel mines cobalt sulphide or Co-Ni-concentrates (Al Barazi 2018).

Finally, artisanal and small-scale mining (ASM) from the DRC contributes a considerable amount to the primary supply of cobalt. The relative proportion of ASM in the DRC fluctuates greatly depending on the development of large-scale mining (Al Barazi 2018). A share of between 15% and 20% of the DRC's total cobalt production is estimated to originate from ASM mine sites in the period 2015 – 2018 (BGR, 2019)(Al Barazi et al. 2018). CRU reports that the ASM supply from the DRC increased strongly in 2017 and 2018 driven by the high cobalt prices, and contributed significantly to bridge the global supply gap in 2017 (CRU 2018). In 2018, the ASM production is reported to 18,000 tonnes (BGR, 2019). However, ASM production is expected to decrease in 2019 compared to production in 2016 to 2018 due to the lower global cobalt prices, but it is estimated to continue to amount to 15%-20% of total production in DRC due to the expected decline in industrial cobalt production (BGR, 2019).

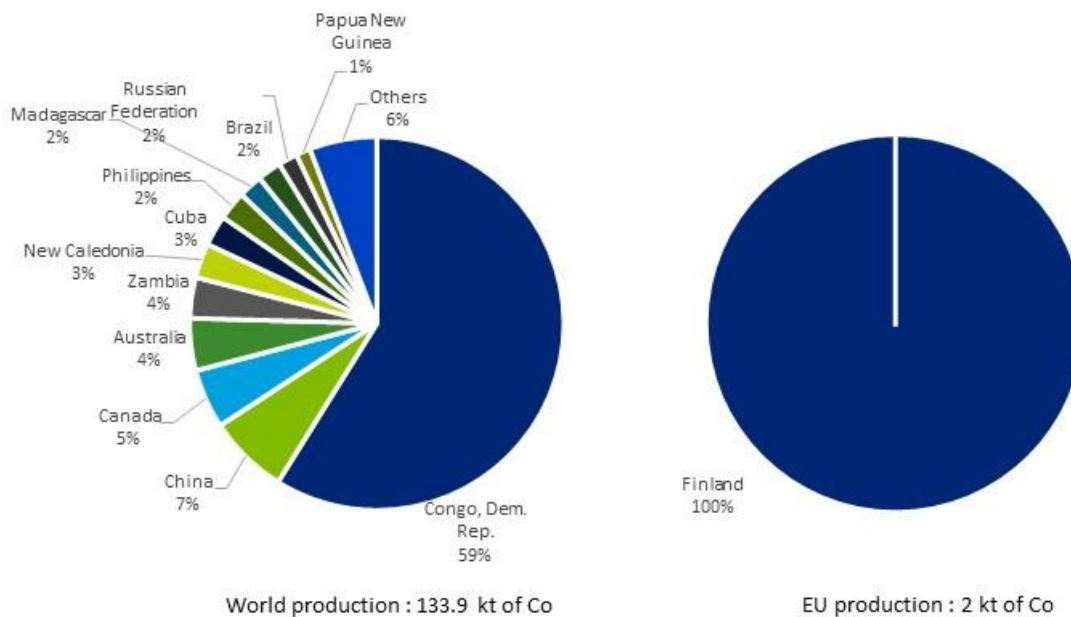
#### **7.4.2.4 Production of cobalt intermediates**

Cobalt-containing ores and concentrates are usually processed into intermediate products before refined production is possible. The process is often undertaken internally by integrated operations (Roskill 2014). A variety of pyrometallurgical and hydrometallurgical techniques are applied for intermediates production (Roberts and Gunn 2014). Cobalt intermediates produced from copper ores include crude mixed hydroxide precipitates, alliage blanc, cobalt crude carbonates and sulphates. From nickel ores, cobalt intermediates include Ni-Co or Ni-Cu-Co (-PGMs-Au-Ag) sulphide mattes, Ni-Co mixed sulphide or hydroxide precipitates, Co oxide sinters (Roskill 2014) (Al Barazi 2018). Each product has different cobalt content. Intermediate products are sent to captive refining operations or abroad or sold to refining companies (Roskill 2014).

#### **7.4.2.5 World and EU cobalt mine production**

In the analysed period 2012-2016, cobalt was mined in 21 countries. World production of cobalt was about 134 kt per annum (five-year average over 2012-2016). As shown in Figure 101, the Democratic Republic of Congo dominated global mine production producing nearly 79 kt with a share of 59% of the worldwide total. China (7%), Canada (5%), Australia (4%) and Zambia (4%) are other significant producers and together with the DRC account for 79% of world's mine production.

Within the EU, cobalt is mined in Finland (1% of the global total). The average EU production of cobalt ores and concentrates is about 2 kt per year in the period 2012-2016. Cobalt is also produced in New Caledonia (French overseas territory) representing 3% of the global output (WMD 2019).



**Figure 101: Global and EU mine production of cobalt. Average for the years 2012-2016. Data from (WMD, 2019)**

### 7.4.3 Refining of cobalt

Cobalt refining includes a wide variety of hydrometallurgical and electrometallurgical techniques to recover cobalt from ores, concentrates, mattes or other intermediate products, which are often unique to the mineralogy of the ore material and very specific to the production site (Roberts and Gunn 2014). Cobalt refining generally starts after the primary metal (copper or nickel) has been recovered from the concentrated ore or other intermediate crude cobalt product. Refining processes that enable cobalt production can be summarised into three main clusters according to the type of the cobalt-bearing ore (Roskill 2014) (Roberts and Gunn 2014)(Al Barazi 2018):

- *Copper-cobalt sulphides and oxides.* The typical process for cobalt recovery involves roasting of the flotation concentrates to sulphate calcine, sulphuric acid atmospheric leach of the soluble sulphate calcine, copper recovery by solvent extraction and electrowinning, followed by impurity removal and cobalt hydroxide precipitation. Cobalt hydroxide can be marketed to produce chemicals or re-dissolved to recover cobalt metal by electrowinning. Due to the low cobalt recovery in the flotation concentration process for mixed sulphide-oxide ores, an alternative processing route is the direct whole ore leach, followed by solvent extraction to separate copper and cobalt and cobalt hydroxide precipitation;
- *Nickel sulphides.* The flotation concentrate is dried or roasted before smelting in an electric furnace (or flash smelting) to produce a nickel-cobalt sulphide matte suitable for refining. There are many refining techniques for cobalt recovery. In hydrometallurgical refining route, the process typically consists of a leaching stage using acids, chlorine, or ammonia, which is followed by a purification stage by solvent extraction or selective precipitation to separate cobalt and nickel. The final step for cobalt recovery can be hydrogen reduction (i.e. Sherritt process) where cobalt is recovered from the solution as a powder or electrowinning, which produces cobalt cathodes.
- *Nickel laterites.* Nickel laterites are processed mainly by high-pressure acid leach (HPAL), a technique combined with a variety of nickel and cobalt refining processes. A typical product is a mixed Ni (55%)-Co(5%) sulphide precipitate.

Some refineries also process scrap and cobalt intermediates, such as alloys, impure cobalt compounds, mixed metal sulphides, residues, and slags (Roskill 2014).

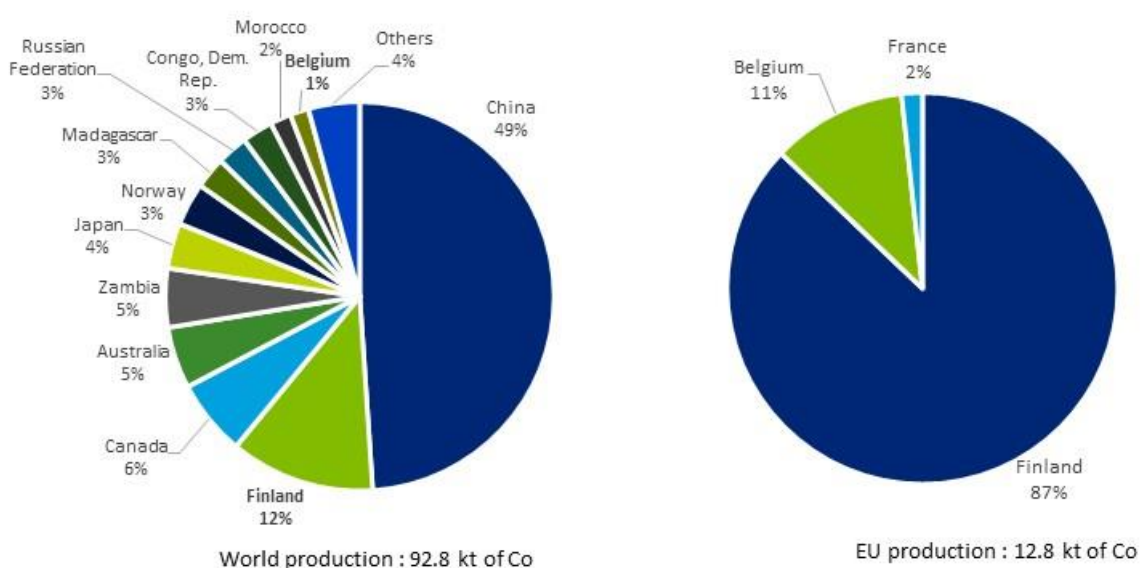


Refined cobalt products include cobalt metal in the form of cathodes, briquettes, ingots, granules and powder, and cobalt chemicals such as cobalt oxide, carbonate, chloride, sulphate, hydroxide, oxalate and acetate (Roskill 2014)(Al Barazi 2018).

### 7.4.3.1 World and EU refined cobalt production

Refined cobalt (including both metal and chemicals) is produced in 17 countries worldwide. The relative share of the global total held by the top producing countries, based on a five year average over 2012-2016, is shown in Figure 102. China dominates refined cobalt production, accounting for almost half of the world total (49%). Other significant cobalt refiners are Finland (12%), Canada (6%), Australia (5%), Zambia (5%), Japan (4%) and Norway (4%). The world production of refined cobalt totalled about 92.8 thousand tonnes on average over the period 2012-2016.

In the EU, refined cobalt is produced in Finland (71% of the EU production), Belgium and France.



**Figure 102: Global and EU production of refined cobalt. Average for the years 2012-2016. Data from (USGS 2018)(Draft Co MSA 2019)**

### 7.4.4 Supply from secondary materials/recycling

Price volatility, geopolitics of supply, cost and environmental benefits are among the drivers for cobalt recycling. While specific cobalt uses are dissipative such as pigments in ceramics, paints, and tyre adhesives, cobalt used in applications such as superalloys, hard metals, batteries, and catalysts can be collected and recycled. (Roberts and Gunn 2014) Cobalt-bearing end-of-life scrap can be found in used jet engines, used cemented carbide cutting tools, spent rechargeable batteries, magnets that have been removed from industrial or consumer equipment and spent catalysts (Mathieux et al. 2017). Recycling of alloy and hard metal scrap is generally operated by and within the superalloy and carbide manufacturers, while the recycling of batteries and catalysts is mainly done via the cobalt industry sector or dedicated plants for batteries recycling (Roberts and Gunn 2014) (Sundqvist Ökvist et al. 2018).

According to UNEP (UNEP 2011), the global average end-of-life functional recycling rate (EOL-RR) for cobalt was estimated to be above 50%, the fraction of secondary (scrap) metal in the total input to metal production to range between 25% and 50%, and the share of old scrap in the total scrap flow (old scrap ratio) to be between 25% and 50%.

Recycling of end-of-life products is an important source of cobalt supply for the EU. It is estimated that 22% of the EU annual consumption of cobalt was sourced from end-of-life scrap in 2016 (Draft Co MSA 2019).

#### 7.4.4.1 Post-consumer recycling (old scrap)

Cobalt content in end-of-life rechargeable batteries makes up a substantial secondary resource. Currently, the material attracting the most interest in Li-ion battery recyclers is cobalt (Mathieux et al. 2017). Recycling of cobalt in batteries is favoured as batteries are well collected at end-of-life because of EU waste legislation. The primary issues connected with cobalt recovery from spent batteries are sorting and identification of battery composition (Sundqvist Ökvist et al. 2018). In 2016 the EU the EOL recycling rate of cobalt was estimated to be 32%, considering 100% of recycling of electrical vehicles batteries (Draft Cobalt MSA 2019).

Significant opportunities to recycle cobalt from EV batteries may be anticipated over the coming years. Large-scale recycling can be expected beyond 2025. This projection is based on an average estimated lifetime of EVs of eight years (Patrícia Alves Dias et al. 2018).

The process choice for cobalt recovery from spent batteries depends on the type of cobalt-bearing battery. Usually, large Ni-Co smelters are also able to recover cobalt from spent batteries.

In cases where the old scrap of cobalt-bearing alloys is separately collected (e.g. superalloys) it can be remelted directly in the form of the original alloy for the same application (e.g. turbine blades, parts of jet engines, magnets) under the constraint that the composition of the alloy is certified or can be assured (European Commission 2017). The recycling rate for gas turbine engines, aircraft and rockets is reported 90% and for magnets 10% (Harper, Kavlak, and Graedel 2012). Co-bearing scrap can also be recycled industrially in sulphide smelter by mixing alloy scrap with primary cobalt sulphide concentrates. Alloy scrap (usually Ni-Co) is also treated using hydrometallurgical methods, allowing the separation and recovery of other valuable elements (W, Ta, Re) in addition to nickel and cobalt (Sundqvist Ökvist et al. 2018).

For spent catalysts, the recycling technology involves pyrometallurgical and hydrometallurgical techniques. According to Harper and colleagues (Harper, Kavlak, and Graedel 2012) only catalysts from plastics manufacture are available for recycling, but not catalysts used in petroleum refining (which are re-generated for reuse). Cobalt in cemented carbide products can be recovered for retooling and reuse (Cobalt Institute 2019d); and after the use phase, these can be recycled, for example by dissolution in molten zinc and zinc distillation (Sundqvist Ökvist et al. 2018). The rest of cobalt uses are dissipative, e.g. pigments, tyre adhesives, foodstuffs, pharmaceutical, meaning that the cobalt is not available for recycling.

According to the updated MSA study of cobalt, the end-of-life recycling input rate is 22%. The relevant flows are presented in Table 42.

**Table 42: Material flows relevant to the EOL-RIR of cobalt<sup>68</sup> in 2016. Data from (Draft Co MSA 2019)<sup>69</sup>**

MSA Flow	Quantity (t)
----------	--------------

<sup>68</sup>  $EOL-RIR = (G.1.1 + G.1.2) / (B.1.1 + B.1.2 + C.1.3 + D.1.3 + C.1.4 + G.1.1 + G.1.2)$

<sup>69</sup> The work carried out in 2019 increased the resolution of the MSA system. Therefore, there are changes in flows in comparison with the previous MSA methodology. B1.1 and B1.2 in the table is the result of the EU

B.1.1 Production of primary material as main product in EU sent to processing in EU	0
B.1.2 Production of primary material as by-product in EU sent to processing in EU	2,224
C.1.3 Imports to EU of primary material	10,220
C.1.4 Imports to EU of secondary material	308
D.1.3 Imports to EU of processed material	8,512
E.1.6 Products at end-of-life in EU collected for treatment	20,910
F.1.1 Exports from EU of manufactured products at end-of-life	215
F.1.2 Imports to EU of manufactured products at end-of-life	311
G.1.1 Production of secondary material from post-consumer functional recycling in EU sent to processing in EU	1,983
G.1.2 Production of secondary material from post-consumer functional recycling in EU sent to manufacture in EU	4,059

#### 7.4.4.2 Industrial recycling (new scrap)

Scrap metal is also generated during manufacturing of alloys and other cobalt-bearing materials and products (sometimes referred to as 'new scrap' or 'processing scrap'). New scrap can be in the form of material that did not meet required specifications, excess metal removed during pressing or forging, rejects from casting operations, grinding sludge or turnings waste from machining operations, swarf etc. Because of the cost of purchasing of raw materials, it is clearly in the manufacturer's interest to minimise the generation of 'new scrap' and to recycle these materials within the manufacturing process (Shedd 2004).

#### 7.4.4.3 Cobalt recovery from industrial by-products and mine tailings

Cobalt can be recovered from sludge generated in nickel refinery and zinc smelting waste with the application of hydrometallurgical techniques (Sundqvist Ökvist et al. 2018). Slags from copper smelting operations in Zambia and the DRC are another secondary source of cobalt (Roberts and Gunn 2014). The H2020 project METGROW+ (2016-2020) is currently studying the extraction of cobalt from fayalitic and Fe-Ni slag (Mäkinen et al. 2018).

Due to the increased demand for cobalt and recent advances in processing technology, it is also possible to extract cobalt from the historic flotation tailings of copper sulphide ores with commercial grades of cobalt, like the ones found in the Democratic Republic of Congo. In these, cobalt was present in the original ores but was not previously recovered due to the low efficiency of the flotation process (Hannis and Bide 2009)(Sundqvist Ökvist et al. 2018) (Roskill 2014). The French Geological Survey (BRMG) has developed a bioleaching technology applied in the re-processing of sulphidic mine wastes at the Kasese Tailings site in Uganda, where cobalt was produced from old copper mining waste tailings (D'Hugues et al. 2019). In the DRC, a major project is under construction, which comprises the reprocessing of old cobalt and copper tailings from previous mining operations around Kolwezi, with an annual capacity of 24,000 tonnes of Co (Mining Weekly 2018).

---

extraction after exports (MSA flows B1.1 + B1.2 – B1.3); C1.4 incorporates all secondary raw material imported to the EU both for the processing and manufacturing stages (MSA flows C1.4 and D1.9). D1.3 Incorporates imports to the EU of both semi-processed and processed material stages (MSA flows D1.3 and C1.8).

## 7.5 Other considerations

---

### 7.5.1 Environmental and health and safety issues

A wide range of cobalt-containing substances is covered by Regulation (EC) 1907/2006 concerning the Registration, Evaluation, Authorisation and Restriction of Chemicals (REACH). Appropriate measures for handling and use are required. Cobalt metal, the five cobalt salts (see below), and other cobalt compounds have been registered for REACH, and this data is available on the ECHA website. For example, cobalt metal is currently classified as carcinogenic (by inhalation) and is a skin and respiratory sensitiser (ECHA 2019b). A formal (legal) classification of cobalt metal as CMR (Carc. 1B by all exposure routes), skin sensitizer Cat. 1 and respiratory sensitizer Cat. 1 as well as aquatic chronic Cat. 4 has been adopted by the Commission and is currently undergoing scrutiny by EP and Council. In case EP and Council do not object, the classification will enter into force in Spring 2020. Entry into application takes place 18 months after entry into force.

Among the cobalt substances, the salts cobalt diacetate, cobalt dinitrate, cobalt carbonate and cobalt sulphate are on the Candidate List for Authorisation of Substances of Very High Concern (SVHC) since 2010, and cobalt dichloride since 2008. Each of the five cobalt salts is classified as carcinogenic (Article 57a of the REACH Regulation) and toxic for reproduction (Article 57c of the REACH Regulation) (ECHA 2019a). In December 2018, in order to reduce the risk of developing cancer following occupational exposure, the European Chemicals Agency (ECHA) launched a public consultation and proposed a REACH restriction on the manufacture and use of these five cobalt salts as substances on their own or in mixtures in a concentration equal to or above 0.01% by weight in industrial and professional applications. According to the proposed restriction, the cobalt salts would not be able to be manufactured, placed on the market or used unless a reference exposure limit value is demonstrated (ECHA 2018). The proposed restriction is still undergoing review and consultation, and the exposure limit value is being assessed. The use of the five cobalt salts as an additive in feedstuffs within the scope of Regulation (EC) 1831/2003 on additives for use in animal nutrition is already authorised and, therefore, exempted from the restriction proposal (ECHA 2018).

Concerning the potential impact of REACH on defence applications, the cobalt salts included in the REACH Candidate List are critical in applications for nickel-based corrosion protection, e.g. in humidity indicator or for superalloys in aerospace used for jet engines and landing gears (EDA 2018).

### 7.5.2 Contribution to low-carbon technologies

Cobalt is a material of significance in the implementation of the European Commission's long-term strategy for a modern, competitive, prosperous and climate-neutral economy by 2050<sup>70</sup>. Cobalt is a raw material used in rechargeable batteries for electric vehicles and energy storage. These two applications are a crucial low-carbon technology for energy storage and transport. Cobalt in cathode chemistries in Li-ion batteries for vehicles (i.e. lithium-nickel-manganese-cobalt-oxide batteries) provides higher energy density and thus longer distances per charge (Blagoeva et al. 2016). Besides, energy storage emerges as a key enabling technology for addressing the flexibility requirements for integrating variable renewable energy (such as solar power, wind power and biogas) into the grid and for providing green electricity for electrified transport, industry and buildings sectors (European Commission 2018). Cobalt-based alloys are among the available alternatives

---

<sup>70</sup> [https://ec.europa.eu/clima/policies/strategies/2050\\_en](https://ec.europa.eu/clima/policies/strategies/2050_en)

for manufacturing magnets for wind turbines (Cobalt Institute 2019a); however, especially for large turbines (> 5 MW), the market is dominated by NdFeB magnets (Pavel et al. 2016).

### **7.5.3 Socio-economic issues**

The leading world supplier of cobalt, the Democratic Republic of the Congo (DRC), is considered one of the countries with highest risk for business, with very poor governance according to on the Worldwide Governance Indicators (WGI) developed by the World Bank. The ranking calculated for DRC is the seventh-highest (i.e. seventh-worst) of the 216 countries included; and the top six (most) riskiest countries for business are identified as the Democratic Republic of Korea, Libya, Somalia, South Soudan, Soudan and Syria Arab Republic (World Bank 2018).

A varying part of the cobalt produced in DRC stems from artisanal and small-scale mining (ASM) (see Section 1.4.2.2). Amnesty International reports that approximately 110K to 150k artisanal miners are likely to be involved in ASM in the southern part of the country, who work alongside industrial operations (Amnesty International 2017). A recent study by (BGR 2019) estimates that the number of active miners in 2017/2018 were approximately 150k to 200k, as a result of internal migration towards the Lualaba and Haut Katanga provinces driven by the cobalt price increase and looking for better livelihood.

In this context, artisanal miners are exposed to landslide hazard, heavy metals through dust inhalation, food and water contamination, and radiation. Poor sanitary conditions and insufficient safety measures in artisanal miners' camps are often observed. Hard working conditions and widespread child labour are also reported (Al Barazi et al. 2018) (Tsurukawa, Prakash, and Manhart 2011). Despite these negative aspects, artisanal cobalt mining plays a crucial role in the local livelihoods and socio-economic landscape of the Katanga and Lubumbashi province (Tsurukawa, Prakash, and Manhart 2011). It is also noted that according to the provisions of the DRC Mining Code, ASM is a legal activity on formally designated artisanal mining areas (Al Barazi 2018).

ASM of cobalt takes place Cobalt is mined in the southern province of Katanga. This region affected by human rights abuses such as child labour and unacceptable working conditions. However, it should be noted that child labour is predominantly linked with illegal or poorly regulated artisanal mining. Cobalt is not covered by EU Regulation 2017/821 on "laying down supply chain due diligence obligations for Union importers of tin, tantalum and tungsten, their ores, and gold originating from conflict-affected and high-risk areas". However, given the high social risk associated with the cobalt supply chains, several initiatives on responsible sourcing of cobalt have been developed in the last years. For example, the Cobalt Institute has launched in 2019 a new framework, the Cobalt Industry Responsible Assessment Framework (CIRAF), to assess the risks and demonstrate responsible sourcing. CIRAF builds on the leading global standard on responsible mineral supply chains such as the OECD 'Due Diligence Guidance for Responsible Supply Chains of Minerals from Conflict-Affected and High-Risk Areas (OECD DDG)' (Cobalt Institute 2019f).

## **7.6 Comparison with previous EU assessments**

---

The assessment has been conducted using the same methodology as for the 2017 list. Supply risk has been analysed at the extraction (mining), and processing (refining) stages of the value chain. In the 2017 assessment two separate criticality assessments were also carried out, the first at the ores and concentrates stage, and the second at the processing stage (refined material stage). The results of this review and earlier assessments are

shown in Table 43. The results for the 2017 assessment correspond to the extraction stage, as it was evaluated to be the bottleneck in the EU supply chain.

**Table 43: Economic importance and supply risk results for cobalt in the assessments of 2011, 2014, 2017, 2020 (European Commission 2011)(European Commission 2014)(European Commission 2017)**

Assessment	2011		2014		2017		2020	
Indicator	EI	SR	EI	SR	EI	SR	EI	SR
Cobalt	7.1	1.1	6.7	1.6	5.7	1.6	5.8	2.5

The results of the 2011 and 2014 assessments are not comparable due to the introduction of a revised methodology in the 2017 exercise. In particular, the reduction in the economic importance between 2014 and 2017 is induced by the change in methodology for calculating this indicator as the value-added considered in the 2017 criticality assessment corresponds to a 2-digit NACE sector rather than a 'megasector' (which was used in the 2011 and 2014 assessments).

In the current assessment, the Supply Risk (SR) was calculated using both the HHI for global supply and EU supply as prescribed in the revised methodology. The assessment results demonstrate that the extraction stage, together with the imports of cobalt intermediates, has a higher supply risk (SR=2.54) compared to the processing stage (SR=0.49). The overall supply risk for cobalt is considered for the stage with the highest score, i.e. SR=2.54 (rounded to SR=2.5).

The values of the Supply Risk indicator are not directly comparable to the 2017 assessment. A different approach has been applied in the current assessment to reflect more accurately the market in the stages of extraction and processing. In particular, the trade of intermediate cobalt products requiring further refining was allocated to the extraction stage, whereas in the 2017 assessment they were considered as part of the processing (refining) stage. This approach is more realistic for evaluating the supply risk in the extraction and the processing stage separately. Cobalt intermediates are the saleable products of the cobalt mining companies and are utilised as a feedstock by cobalt refineries. Furthermore, the trade volume in Co ores and concentrates is following a strong downward trend in recent years because of a general preference of consumers in refineries worldwide for semi-processed materials rather than concentrates. In the previous assessments, only the trade of ores and concentrates was accounted for in the extraction stage, and the trade of intermediate cobalt compounds was entirely allocated to the processing/refining stage as part of bulk refinery imports.

The calculation of Economic Importance indicator is based on the use of the NACE 2-digit codes, and the value added at factor cost for the identified sectors (see Table 38). For information relating to the application share of each category, see Section 7.3.2 on applications and end-uses. Since the majority of the applications shown as "others" refer to chemical applications, the NACE 2-digit sector "C20" was allocated. In the 2020 assessment, the value-added data used in the calculation of economic importance relate to 5-year average 2012-2016 values.

## 7.7 Data sources

Production data for the extraction stage were sourced from the 'World Mining Data' datasets, developed by the Austrian Ministry for Sustainability and Tourism and the International Organising Committee for the World Mining Congress. The source for refined cobalt production was the US Geological Survey, with the exception of production from

Belgium, for which the datasets developed by the ongoing MSA study were utilised, as it was possible to disaggregate Umicore's production in Belgium and in China (publicly available sources do not provide this disaggregation); therefore, production of refined cobalt from China reported by the USGS has been also adjusted accordingly.

Trade data were extracted from the Eurostat (Comext) database under the Combined Nomenclature (CN) codes 26050000 'cobalt ores and concentrates', 28220000 'cobalt oxides and hydroxides', 28273930 for 'cobalt chlorides' and 81052000 'cobalt mattes and other intermediate products of cobalt metallurgy; unwrought cobalt; cobalt powders', adjusted for different cobalt contents (as described in the overview).

The analysis for 'mattes and other intermediate products of cobalt metallurgy; unwrought cobalt; cobalt powders' (CN code: 81052000) is challenging as this trading code is highly aggregated with products of varying cobalt content. In particular, 'mattes and other intermediate products' are assumed to contain 17% cobalt, while the 'unwrought cobalt' or 'powders' are likely to be 100% cobalt, and there are no data available to allow the user to distinguish the quantity of each within this trade code. As in the 2017 criticality assessment, given that the average cobalt prices in the period 2010-2014 have been similar to the prevailing average rates in the period 2012-2016, the trade data recorded against this code were adjusted by taking account the value recorded in the trade statistics. If the value divided by the quantity resulted in an average price of less than €10 per kilogram, the trade quantity was assumed predominantly 'intermediate', and a cobalt content of 17% was used. If the calculated average price was between €10 and €20 per kilogram, it was assumed a cobalt content of 60%. If the calculated average price was higher than €20 per kilogram, it was assumed the traded quantity had a cobalt content of 100%. Other organisations conducting a similar exercise may use different cut-off values and/or different cobalt contents for intermediate products, and therefore, the results will be different.

Another challenge with data availability that had to be overcome in the current assessment is the fact that since 2014 imports of CN 81052000 to Finland are not reported by Eurostat (apparently, they have become confidential). Nevertheless, statistics of the Finnish Customs (ULJAS 2019) do report data on imports of the above trade code, even though in an aggregated form and only in value (quantity is not reported). Therefore, the imports value (in EUR) was employed to calculate an average figure of EUR/kg for CN 81052000 for imports and this allowed to estimate imports to Finland for 2015 and 2016. It was also assumed that all Finnish imports for 2015 and 2016 had the DRC as an origin and intermediate products with a value of less than EUR 10 per kg consisted of intermediate cobalt hydroxide, with a typical cobalt content of 17% (Roskill 2014).

The EOL-RIR is calculated from the preliminary datasets developed in the context of the ongoing cobalt MSA study (Draft Co MSA 2019), whereas the market shares of the cobalt applications by the EU manufacturing industry was provided by a recent study carried out by the Cobalt Institute. Other data sources have been mentioned elsewhere in this factsheet.

### **7.7.1 Data sources used in the factsheet**

Ait Abderrahim, A. and Monnet, A. (2018) Report on major trends affecting future demand for critical raw materials. SCRREEN project D.2.2. Available at: <http://screen.eu/results/>.

Alves Dias, P. et al. (2018) Cobalt: demand-supply balances in the transition to electric mobility. doi: 10.2760/97710.

Amnesty International (2017) Time to recharge; Corporate action and inaction to tackle abuses in the cobalt supply chain. Available at: [www.amnesty.org](http://www.amnesty.org).

- Al Barazi, S. et al. (2018) Commodity top news (53). Cobalt from the DR Congo – potential, risks and significance for the global cobalt market.
- Al Barazi, S. (2018) Rohstoffrisikobewertung – Kobalt. – DERA Rohstoffinformationen 36. Berlin.
- Battery University (2018) Types of Lithium-ion Batteries. Available at: [https://batteryuniversity.com/learn/article/types\\_of\\_lithium\\_ion](https://batteryuniversity.com/learn/article/types_of_lithium_ion) (Accessed: 1 July 2019).
- BGR (2019) Mapping of the Artisanal Copper-Cobalt Mining Sector in the Provinces of Haut-Katanga and Lualaba in the Democratic Republic of the Congo. Available at: [https://www.bgr.bund.de/EN/Themen/Min\\_rohstoffe/Downloads/studie\\_BGR\\_kupfer\\_kobalt\\_kongo\\_2019\\_en.html](https://www.bgr.bund.de/EN/Themen/Min_rohstoffe/Downloads/studie_BGR_kupfer_kobalt_kongo_2019_en.html).
- BGS (2019) World mineral statistics data, British Geological Survey. Available at: <https://www.bgs.ac.uk/mineralsuk/statistics/wms.cfc?method=searchWMS>.
- BIO Intelligence Service (2015) Study on Data for a Raw Material System Analysis: Roadmap and Test of the Fully Operational MSA for Raw Materials. Available at: <https://ec.europa.eu/jrc/en/scientific-tool/msa>.
- Blagoeva, D. et al. (2016) Assessment of potential bottlenecks along the materials supply chain for the future deployment of low-carbon energy and transport technologies in the EU. Wind power, photovoltaic and electric vehicles technologies, time frame: 2015-2030. doi: 10.2790/08169.
- Boliden (2019a) Summary Report. Resources and Reserves. 2018. Kevitsa Mine. Available at: <https://www.boliden.com/operations/exploration/mineral-reserves-and-mineral-resources>.
- Boliden (2019b) Summary Report. Resources and Reserves. 2018. Kylylahti Mine. Available at: <https://www.boliden.com/operations/exploration/mineral-reserves-and-mineral-resources>.
- BRGM (2017) 'Le cobalt (Co) – éléments de criticité'. Available at: <http://www.mineralinfo.fr/page/fiches-criticite>.
- Bunsen, T. et al. (2019) Global EV Outlook 2019. Scaling-up the transition to electric mobility, Global EV Outlook. Available at: [www.iea.org/publications/reports/globalevoutlook2019/](http://www.iea.org/publications/reports/globalevoutlook2019/).
- Cobalt Institute (2018) Innovation and Substitution. Cobalt Institute. Available at: <https://www.cobaltinstitute.org/innovation-and-substitution.html> (Accessed: 1 July 2019).
- Cobalt Institute (2019a) A sustainable planet, Cobalt Institute webpage. Cobalt Institute. Available at: <https://www.cobaltinstitute.org/a-sustainable-planet.html> (Accessed: 7 August 2019).
- Cobalt Institute (2019b) Cobalt production statistics. Cobalt Institute. Available at: <https://www.cobaltinstitute.org/statistics.html> (Accessed: 18 August 2019).
- Cobalt Institute (2019c) Cobalt uses. Core Applications, Cobalt Institute webpage. Cobalt Institute. Available at: <https://www.cobaltinstitute.org/core-applications.html> (Accessed: 7 August 2019).
- Cobalt Institute (2019d) 'Comments from Cobalt Institute provided to DG GROW following the CRM Ad Hoc Working Group meeting and SCRREEN Experts Workshop.'
- Cobalt Institute (2019e) Socio-economic analysis of the cobalt industry in the EEA. Summary Report by Roskill. October (in preparation).
- Cobalt Institute (2019f) The Cobalt Industry Responsible Assessment Framework (CIRAF).



- Cobalt Institute. Available at: [https://www.cobaltinstitute.org/the-cobalt-industry-responsible-assessment-framework-\(ciraf\).html](https://www.cobaltinstitute.org/the-cobalt-industry-responsible-assessment-framework-(ciraf).html) (Accessed: 1 October 2019).
- CRU (2018) 'Artisanal mining will balance the cobalt market', pp. 1–10. Available at: <https://www.crugroup.com/knowledge-and-insights/insights/2018/artisanal-mining-will-balance-the-cobalt-market/>.
- D'Hugues, P. et al. (2019) 'Biohydrometallurgy for treatment of low grade resources: the Kasese site, Uganda', in Blengini, G. A. et al. (eds) Recovery of critical and other raw materials from mining waste and landfills: State of play on existing practices. European Commission. Joint Research Centre. doi: 10.2760/494020.
- DERA (2017) 'Chart des Monats, März 2017. Starker Preisanstieg von Kobalt und Lithium'. Available at: [https://www.deutsche-rohstoffagentur.de/DERA/DE/Publikationen/Chart\\_des\\_Monats/cdm\\_node.html](https://www.deutsche-rohstoffagentur.de/DERA/DE/Publikationen/Chart_des_Monats/cdm_node.html).
- DERA (2018) 'Chart des Monats, Juni 2018. Neue DERA Rohstoffrisikobewertung – Kobalt', p. 2018. Available at: [https://www.deutsche-rohstoffagentur.de/DERA/DE/Publikationen/Chart\\_des\\_Monats/cdm\\_node.html](https://www.deutsche-rohstoffagentur.de/DERA/DE/Publikationen/Chart_des_Monats/cdm_node.html).
- Draft Co MSA (2019) Results of the cobalt MSA Study. Internal document – not published. Reference date: 17 December 2019.
- ECHA (2018) ANNEX XV Restriction report. Proposal for a restriction. Substance names: cobalt sulphate; cobalt dinitrate; cobalt dichloride; cobalt carbonate; cobalt di(acetate). Available at: <https://echa.europa.eu/registry-of-restriction-intentions/-/dislist/details/0b0236e181d575c8>.
- ECHA (2019a) Candidate List of substances of very high concern for Authorisation. Available at: <https://www.echa.europa.eu/candidate-list-table> (Accessed: 7 July 2019).
- ECHA (2019b) Information on Chemicals. Available at: <https://echa.europa.eu/information-on-chemicals> (Accessed: 12 August 2019).
- Ecorys (2014) Study to investigate state of knowledge of Deep Sea Mining. Final report Annex 1. Geological Analysis. Available at: <https://webgate.ec.europa.eu/maritimeforum/en/node/3732>.
- EDA (2018) Position Paper On the impact of the entanglement of REACH Regulation , Critical Raw Materials and Circular Economy on European Defence.
- Eramet (2019) '2018 Registration document Document de référence 2018'.
- ESTAT Comext (2019) Easy Comext database. Available at: <http://epp.eurostat.ec.europa.eu/newxtweb/>.
- European Commission (2011) Critical raw materials. Available at: [https://ec.europa.eu/growth/sectors/raw-materials/specific-interest/critical\\_en](https://ec.europa.eu/growth/sectors/raw-materials/specific-interest/critical_en) (Accessed: 8 July 2019).
- European Commission (2014) Report on critical raw materials for the EU - Critical raw materials profiles. Available at: <https://ec.europa.eu/docsroom/documents/11911/attachments/1/translations/en/renditions/pdf>.
- European Commission (2017) Study on the review of the list of critical raw materials. Critical Raw Material Factsheets. European Commission. doi: 10.2873/398823.
- European Commission (2018) In-depth analysis in support of the Commission Communication COM(2018)/773. 'A Clean Planet for all. A European strategic long-term vision for a prosperous, modern, competitive and climate neutral economy'. Available at: [https://ec.europa.eu/clima/sites/clima/files/docs/pages/com\\_2018\\_733\\_analysis\\_in](https://ec.europa.eu/clima/sites/clima/files/docs/pages/com_2018_733_analysis_in)

\_support\_en\_0.pdf.

European Commission (2019a) Negotiations and agreements. Available at: <http://ec.europa.eu/trade/policy/countries-and-regions/negotiations-and-agreements/> (Accessed: 7 July 2019).

European Commission (2019b) The EU Blue Economy Report 2019. Luxembourg: Publications Office of the European Union. doi: 10.2771/21854.

Eurostat (2019) Annual detailed enterprise statistics for industry (NACE Rev. 2, B-E). Available at: [https://ec.europa.eu/eurostat/en/web/products-datasets/-/SBS\\_NA\\_IND\\_R2](https://ec.europa.eu/eurostat/en/web/products-datasets/-/SBS_NA_IND_R2) (Accessed: 7 July 2019).

Fastmarkets (2019a) Battery Raw Materials Report 31/05: An Cobalt hydroxide payables under pressure against relative strength in metal. Available at: <https://www.fastmarkets.com/article/3876680/battery-raw-materials-market-report-31-05-cobalt-hydroxide-payables-under-pressure-against-relative> (Accessed: 1 July 2019).

Fastmarkets (2019b) Cobalt prices. Available at: <https://www.fastmarkets.com/commodities/minor-metals/cobalt> (Accessed: 1 July 2019).

Fastmarkets (2019c) The battery boom and emerging spot cobalt hydroxide market. Available at: <https://www.fastmarkets.com/article/3856139/comment-the-battery-boom-and-emerging-spot-cobalt-hydroxide-market> (Accessed: 1 July 2019).

Fastmarkets (2019d) Why is cobalt trading below \$20/lb? Available at: <https://www.fastmarkets.com/article/3863256/battery-materials-blog-why-is-cobalt-trading-below-20-lb> (Accessed: 1 July 2019).

FODD (2017) Fennoscandian Mineral Deposits, Fennoscandian Ore Deposit database. V.2017. Available at: <http://en.gtk.fi/information-services/databases/fodd/index.html> (Accessed: 9 August 2019).

Freeport Cobalt (2019) Products for chemical applications. Recycling. Available at: <https://www.freeportcobalt.com/products/chemical.html#recycling> (Accessed: 18 August 2019).

Gautneb, H. et al. (2019) 'Occurrences of energy critical elements; Lithium – Cobalt and Graphite in Europe, a preliminary overview', SGA 2019 - 15th Biennial Meeting of the Society for Geology Applied to Mineral Deposits. Glasgow, United Kingdom, pp. 494–519. doi: 10.1016/j.oregeorev.2019.04.015.

Graedel, T. et al. (2015) 'On the materials basis of modern society', Proceedings of the National Academy of Sciences, 112(20). doi: 10.1073/pnas.1312752110.

GTK (2019a) Mineral Deposit Report. Kevitsa. 8-4-2019. Available at: [http://tupa.gtk.fi/karttasovellus/mdae/raportti/12\\_Kevitsa.pdf](http://tupa.gtk.fi/karttasovellus/mdae/raportti/12_Kevitsa.pdf).

GTK (2019b) Mineral Deposit Report. Kylylahti 10-4-2019. Available at: [http://tupa.gtk.fi/karttasovellus/mdae/raportti/112\\_Kylylahti.pdf](http://tupa.gtk.fi/karttasovellus/mdae/raportti/112_Kylylahti.pdf).

Hannis, S. and Bide, T. (2009) 'Mineral Profile. Cobalt', British Geological Survey, p. 18. Available at: <http://www.bgs.ac.uk/mineralsUK/statistics/mineralProfiles.html>.

Harper, E. M., Kavlak, G. and Graedel, T. E. (2012) 'Tracking the metal of the goblins: Cobalt's cycle of use', Environmental Science and Technology, 46(2), pp. 1079–1086. doi: 10.1021/es201874e.

Kushnir, D. (2015) Lithium-Ion Battery Recycling Technology 2015: Current State and Future Prospects, Environmental Systems Analysis. Göteborg, Sweden. Available at: [http://publications.lib.chalmers.se/records/fulltext/230991/local\\_230991.pdf](http://publications.lib.chalmers.se/records/fulltext/230991/local_230991.pdf).

- Kusigerski, M. (2018) 'Kobalt an der LME. Setting the global standard'. Available at: [https://www.deutsche-rohstoffagentur.de/DERA/DE/Downloads/vortrag-kobalt-kusigerski.pdf?\\_\\_blob=publicationFile&v=3](https://www.deutsche-rohstoffagentur.de/DERA/DE/Downloads/vortrag-kobalt-kusigerski.pdf?__blob=publicationFile&v=3) (Accessed: 1 July 2019).
- Lauri, L. et al. (2018) Identification and quantification of primary CRM resources in Europe. SCREEN project D3.1. Available at: <http://screen.eu/results/>.
- Lebedeva, N., Di Persio, F. and Boon-Brett, L. (2017) Lithium-ion battery value chain and related opportunities for Europe, JRC 105010. doi: 10.2760/75757.
- LME (2019a) LME Cobalt, London Metal Exchange. Available at: <https://www.lme.com/Metals/Minor-metals/Cobalt#tabIndex=0> (Accessed: 24 September 2019).
- LME (2019b) LME Cobalt (Fastmarkets MB), London Metal Exchange. Available at: <https://www.lme.com/en-GB/Metals/Minor-metals/Cobalt-Metal-Bulletin#tabIndex=0> (Accessed: 1 July 2019).
- Mäkinen, J. et al. (2018) METGrow+. D3.6. Report on metal extraction of low grade ores and wastes.
- Mathieux, F. et al. (2017) Critical raw materials and the circular economy - Background report. EUR 28832 EN, Publications Office of the European Union, Luxembourg. doi: 10.2760/378123.
- Mining Weekly (2018) ERG's Metalkol Roan Tailings Reclamation project Phase I nearing completion. Available at: <https://www.miningweekly.com/article/ergs-metalkol-roan-tailings-reclamation-project-phase-i-nearing-completion-2018-12-07> (Accessed: 7 October 2019).
- Moss, R. L. et al. (2011) Critical Metals in Strategic Energy Technologies, JRC-scientific and strategic reports, European Commission Joint Research Centre Institute for Energy and Transport. doi: 10.2790/35600.
- Nornickel (2018) Annual report 2017. Investing in Sustainable Development. Available at: <https://www.nornickel.com/investors/reports-and-results/#2018>.
- OECD (2019) Export Restrictions on Industrial Raw Materials. Available at: [https://qdd.oecd.org/subject.aspx?Subject=ExportRestrictions\\_IndustrialRawMaterials](https://qdd.oecd.org/subject.aspx?Subject=ExportRestrictions_IndustrialRawMaterials) (Accessed: 5 July 2019).
- Pavel, C. C. et al. (2016) Substitution of critical raw materials in low-carbon technologies: lighting, wind turbines and electric vehicles. doi: 10.2790/64863.
- R.D. Congo (2017) Réglementation de la commercialisation et de l'exportation des produits miniers marchands. Democratic Republic of the Congo. Available at: <http://www.droit-afrique.com/uploads/RDC-Arrete-2017-129-produits-miniers-marchands.pdf>.
- Reuters (2019) Cobalt's price crash bottoming out, stocks to hinder quick rally. Available at: <https://www.reuters.com/article/us-cobalt-prices-electric/cobalts-price-crash-bottoming-out-stocks-to-hinder-quick-rally-idUSKCN1Q11EP> (Accessed: 1 July 2019).
- Roberts, S. and Gunn, G. (2014) 'Cobalt', in Gunn, G. (ed.) Critical Metals Handbook. Chichester, UK: British Geological Survey, John Wiley & Sons, American Geophysical Union, pp. 122–149.
- Roskill (2014) Cobalt: Market Outlook to 2018. 12th Edition. Available at: <https://roskill.com/market-reports/>.
- Roskill (2019a) Cobalt: Dramatic price fall comes to an end. Available at: <https://roskill.com/news/cobalt-dramatic-price-fall-comes-to-an-end/> (Accessed: 1 July 2019).

- Roskill (2019b) Lithium-ion Batteries: Outlook to 2028, 3rd Edition.
- Rudnick, R. L. and Gao, S. (2014) Composition of the Continental Crust, Treatise on Geochemistry: Second Edition. Elsevier Ltd. doi: 10.1016/B978-0-08-095975-7.00301-6.
- S&P Global Market Intelligence (2019a) Cobalt. Metals & Mining properties, Market Intelligence Platform. Available at: <https://www.spglobal.com/marketintelligence/en/campaigns/metals-mining> (Accessed: 20 May 2019).
- S&P Global Market Intelligence (2019b) Cobalt Commodity profile. Price charts, Market Intelligence Platform. Available at: <https://www.spglobal.com/marketintelligence/en/campaigns/metals-mining> (Accessed: 28 June 2019).
- Shedd, K. B. (2004) 'Cobalt Recycling in the United States in 1998', in Sibley, S. F. (ed.) Flow Studies for Recycling Metal Commodities in the United States. Circular 1. United States Geological Survey. Available at: [http://pubs.usgs.gov/circ/2004/1196am/c1196a-m\\_v2.pdf](http://pubs.usgs.gov/circ/2004/1196am/c1196a-m_v2.pdf).
- Slack, J. F., Kimball, B. E. and Shedd, K. B. (2017) 'Cobalt. U.S. Geological Survey Professional Paper 1802-F', in Schulz, K. J. et al. (eds) Critical Mineral Resources of the United States—Economic and Environmental Geology and Prospects for Future Supply. US Geological Survey, pp. F1–F40. Available at: <https://doi.org/10.3133/pp1802>.
- Sundqvist Ökvist, L. et al. (2018) Production technologies of critical raw materials from secondary resources. SCRREEN project D.4.2. Available at: <http://screen.eu/results/>.
- Sverdrup, H. U., Ragnarsdottir, K. V. and Koca, D. (2017) 'Integrated Modelling of the Global Cobalt Extraction, Supply, Price and Depletion of Extractable Resources Using the WORLD6 Model', BioPhysical Economics and Resource Quality. Springer International Publishing, 2(1), pp. 1–29. doi: 10.1007/s41247-017-0017-0.
- Tercero, L. et al. (2018) Critical Raw Material substitution profiles. SCRREEN project D5.1., SCRREEN - D5.1. Available at: <http://screen.eu/wp-content/uploads/2018/05/SCRREEN-D5.1-CRM-profiles.pdf>.
- Terrafame (2018a) Terrafame decides to invest in battery chemicals plant. Available at: <https://www.terrafame.com/news-from-the-mine/news/2018/10/terrafame-decides-to-invest-in-battery-chemicals-plant.html> (Accessed: 6 October 2019).
- Terrafame (2018b) Terrafame Ltd Interim report Q2 2018. Available at: <https://www.terrafame.com/media/2018-q/q2/terrafame-q2-2018-interim-report-media-release-eng.pdf>.
- Terrafame Oy (2018) EIA report on battery chemicals production now available – A public event will be held in Vuokatti on 31 October 2018. Available at: <https://www.terrafame.com/news-from-the-mine/news/2018/10/eia-report-on-battery-chemicals-production-now-available-a-public-event-will-be-held-in-vuokatti-on-31-october-2018.html> (Accessed: 6 October 2019).
- Tsurukawa, N., Prakash, S. and Manhart, A. (2011) Öko-Institut. Social impacts of artisanal cobalt mining in Katanga, Democratic Republic of Congo. Freiburg. Available at: [http://resourcefever.com/publications/reports/OEKO\\_2011\\_cobalt\\_mining\\_congo.pdf](http://resourcefever.com/publications/reports/OEKO_2011_cobalt_mining_congo.pdf).
- ULJAS (2019) ULJAS database of international trade - Finnish Customs. Available at: <http://uljas.tulli.fi/uljas/> (Accessed: 10 October 2019).

- UN Comtrade (2019) International Trade Statistics Database. Available at: <https://comtrade.un.org/> (Accessed: 8 July 2019).
- UNEP (2011) Recycling Rates of Metals – A Status Report, A Report of the Working Group on the Global Metal Flows to the International Resource Panel., Group. doi: ISBN 978-92-807-3161-3.
- USGS (2013) Metal prices in the United States through 2010. U.S. Geological Survey Scientific Investigations Report 2012–5188. Available at: <https://pubs.usgs.gov/sir/2012/5188/>.
- USGS (2017) 2015 Minerals Yearbook - Cobalt, USGS Mineral Resources Program. Available at: <https://minerals.usgs.gov/minerals/pubs/commodity/cobalt/myb1-2015-cobal.pdf>[http://minerals.usgs.gov/minerals/pubs/commodity/soda\\_ash/myb1-2015-sodaa.pdf](http://minerals.usgs.gov/minerals/pubs/commodity/soda_ash/myb1-2015-sodaa.pdf).
- USGS (2018) 2016 Minerals Yearbook - Cobalt\_tables-only release. Available at: <https://www.usgs.gov/centers/nmic/cobalt-statistics-and-information>.
- USGS (2019) Mineral Commodity Summaries 2019. U.S Geological Survey. doi: 10.1007/978-3-540-47108-0-4.
- WMD (2019) World Mining Data 2019, Reichl, C.; Schatz, M; Zsak, G. Iron and Ferro Alloy Metals, non Ferrous Metals, Precious Metals, Industrial Minerals, Mineral Fuels. Austrian Federal Ministry of Sustainability and Tourism. [online] Available at: [www.en.bmwf.gv.at/Energy/WorldMiningData/Seiten/default.aspx](http://www.en.bmwf.gv.at/Energy/WorldMiningData/Seiten/default.aspx)
- World Bank (2018) Aggregate Governance Indicators 1996-2017, Worldwide Governance Indicators. Available at: <http://info.worldbank.org/governance/WGI/#home> (Accessed: 7 July 2019).

### **7.7.2 Data sources used in the criticality assessment**

- WMD (2019) World Mining Data 2019, Reichl, C.; Schatz, M; Zsak, G. Iron and Ferro Alloy Metals, non Ferrous Metals, Precious Metals, Industrial Minerals, Mineral Fuels. Austrian Federal Ministry of Sustainability and Tourism. [online] Available at: [www.en.bmwf.gv.at/Energy/WorldMiningData/Seiten/default.aspx](http://www.en.bmwf.gv.at/Energy/WorldMiningData/Seiten/default.aspx)
- USGS (2017) *2015 Minerals Yearbook - Cobalt, USGS Mineral Resources Program*. Available at: <https://minerals.usgs.gov/minerals/pubs/commodity/cobalt/myb1-2015-cobal.pdf>[http://minerals.usgs.gov/minerals/pubs/commodity/soda\\_ash/myb1-2015-sodaa.pdf](http://minerals.usgs.gov/minerals/pubs/commodity/soda_ash/myb1-2015-sodaa.pdf).
- USGS (2018) *2016 Minerals Yearbook - Cobalt\_tables-only release*. Available at: <https://www.usgs.gov/centers/nmic/cobalt-statistics-and-information>.
- Draft Co MSA (2019) Results of the cobalt MSA Study. Internal document – not published. Reference date: 17 December 2019.
- Cobalt Institute (2019e) *Socio-economic analysis of the cobalt industry in the EEA. Summary Report by Roskill. October (in preparation)*.
- ESTAT Comext (2019) *Easy Comext database*. Available at: <http://epp.eurostat.ec.europa.eu/newxtweb/>.
- ULJAS (2019) *ULJAS database of international trade - Finnish Customs*. Available at: <http://uljas.tulli.fi/uljas/> (Accessed: 10 October 2019).

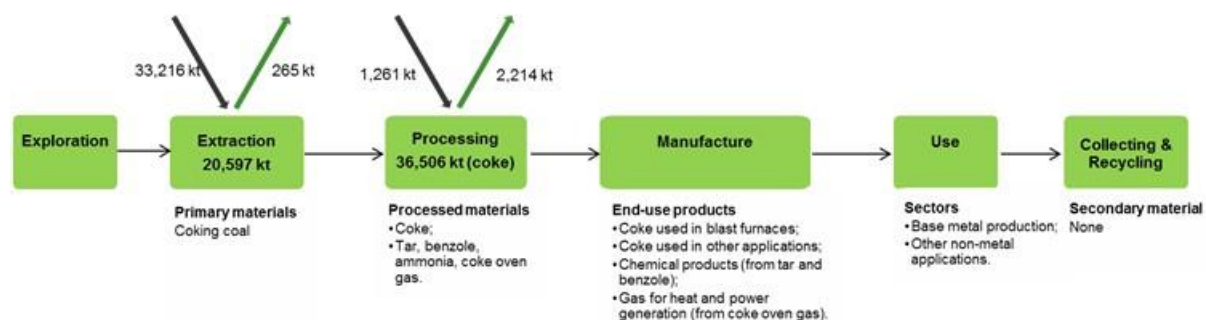
## **7.8 Acknowledgements**

---

The JRC prepared this factsheet. The authors would like to thank the Ad Hoc Working Group on Critical Raw Materials, in particular Ms. Carol Pettit (Cobalt Institute), Mr Asko Käpyaho (Geological Survey of Finland) as well as the experts participating in SCRREEN workshops for their contribution and feedback.

# 8 COKING COAL

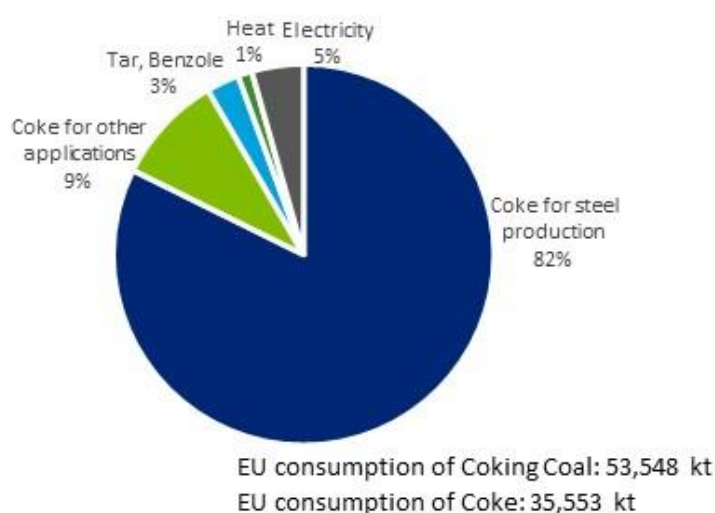
## 8.1 Overview



**Figure 103: Simplified value chain for coking coal<sup>71</sup>**

Coking coal (or metallurgical coal) is a bituminous coal with a suitable quality that allows the production of metallurgical coke, or simply named coke. Coking coal has a higher carbon content than steam coal, as well as a lower level of sulphur, phosphorous and alkalis (World Coal Institute 2009). Coke is the main product of the high-temperature carbonisation of coking coal. Coke is an essential input material in steelmaking as it is used to produce pig iron in blast furnaces acting as the reducing agent of iron ore and as the support of the furnace charge. By-products of coke production such as tar, benzole, ammonia sulphate and sulphur are used for the manufacture of chemicals, as well a coke oven gas used for heat and power generation.

In this assessment, coking coal is analysed in terms of mine production and coke production. The relevant trade code for the extraction stage used is CN code 27011210 “Coking Coal, whether or not pulverised, but not agglomerated”.



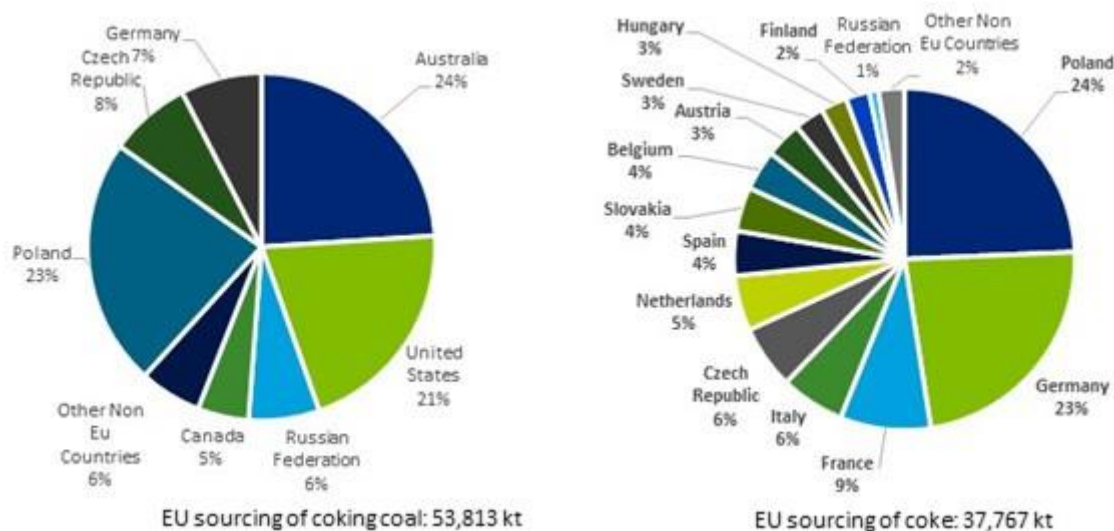
**Figure 104: End uses of coking coal (average 2013-2017) (SCREEN workshop 2019) and EU consumption of coking coal and coke (average 2012-2016) (ESTAT Comext 2019)**

<sup>71</sup> JRC elaboration on multiple sources (see next sections)

For the processing stage the trade codes CN 27040010 'Coke and semi-coke of coal, whether or not agglomerated', CN 27040011 'Coke and semi-coke of coal, whether or not agglomerated, for the manufacture of electrodes', and CN 27040019 'Coke and semi-coke of coal, whether or not agglomerated (excl. For the manufacture of electrodes)' were used. Quantities are expressed in tonnes of coking coal and coke and refer to average values for the period 2012-2016 unless otherwise specified.

The world production of coking coal in 2017 was 1,039,005 kt, with an estimated value of EUR 151 billion. Global import demand is expected to rise by an average annual growth rate of 2.3% (7.5 Mt) from 2017 to 2030. China and Australia are the top coking coal producer and exporter, respectively. The coking coal market is directly associated with iron ore and steel demand. There is a sizeable market in terms of volume, with world exports of coking coal at 327,000 kt in 2017, representing 24% of global hard coal trade.

Coking coal price boomed in 2016. The considerable price volatility in the period 2016-2019 reveals that the coking coal market has become extremely susceptible to supply chain disruptions. In the first semester of 2019, the price of Australian premium hard coking coal was relatively stable at around USD 200/tonne.



**Figure 105: EU sourcing of coking coal and coke.**

In the period 2012-2016, the EU consumption of coking coal was around 53,548 kt. Domestic production took place in Poland, Czechia and Germany. The production in Germany ended in 2018. Imports came mostly from Australia (39% of EU imports) and the United States (33% of EU imports). Import reliance for coking coal was 62%. The annual EU production of coke was around 36,506 kt, and Poland and Germany were the leading producers. The EU was a net exporter of coke.

Iron and steel industry is the primary consumer of coking coal. More than 70% of world steel production is made in blast furnaces fired with coking coal previously processed in coking plants to form coke. In the EU, 90% of the coking coal demand is converted to coke to be used in blast furnaces of the integrated steel processing route. Several chemical products can be produced from the by-products of coke ovens. There is no other satisfactory material available which can replace completely metallurgical coke in the blast furnace charge. Pulverised coal (PCI) is an alternative material for coking coal (coke) up to a certain level, but the industry has already reached the technical limits of replacement.

No information is available for coking coal's resources and reserves. Figures reported for bituminous coal provide a rough indication of coal suitable for coking coal production. US, China, India, Russia and Australia hold the most extensive reserves worldwide for



bituminous coal. Around 22 billion tonnes of bituminous coal reserves are located in the EU, and Poland holds by far the largest amount of reserves (93%) (BP 2018).

More than one billion tonnes of coking coal is produced globally. China dominates the world production of coking coal with more than half of the world output (55%), followed by Australia (16% of the world total). Chinese production is subject to export tax (OECD 2019a). The annual European output of coking coal is around 20,597 kt (WMD 2019). However, since 2019 only Poland and Czechia contribute to European production, as hard coal mining in Germany ended at the end of 2018. Given the type of applications, coking coal is not recyclable (BIO Intelligence Service 2015).

In the context of the EU policy to reduce greenhouse gas emissions<sup>72</sup>, the transition to a lower-carbon economy is challenging to coal-related industries. The European steel industry accounted in 2016 for about 7% of the verified greenhouse gas emissions of all stationary installations of the European Union. Process related CO<sub>2</sub> emissions in the steel industry are a natural result of the oxidisation of coke in the iron-making process. Breakthrough innovative technologies are under development to decarbonise steel production; some are aiming to altogether bypass the use of coal for the production of primary steel (European Commission 2018). Steel, the main end-use of coking coal, is present in all industry sectors, including the construction of wind turbines. Some products derived from the by-products of the coking process such as carbon fibres are associated with innovative low-carbon technologies.

## 8.2 Market analysis, trade and price

---

### 8.2.1 Global market

The worldwide production of coking coal in 2017 was 1,079,497 kt accounting for about 17% of the total hard coal production worldwide (WMD, 2019). China is the largest producer of coking coal, with more than half of the global supply (52% in 2017). Chinese production increased by more than three times since 2000 to peak at about 620,000 kt in 2014 but subsequently dropped to 540,000 kt in 2017 (IEA 2018) (WMD, 2019). Other significant producers are Australia (18%), Russia (8%) and the USA (6%). Since 2010, world production of coking coal has been relatively stable at levels of between 900,000 and 1,100,000 kt (WMD, 2019). The rise of hard coal prices on the world market since the summer of 2016 ended the wave of mine closures worldwide with high production costs that had continued over several years (BGR 2017). The value of coking coal production was roughly estimated at EUR 151 billion<sup>73</sup> in 2017.

Coking coal trade reflects the demand for iron ore, pig iron and crude steel (Euracoal 2017). There has been a substantial increase in coking coal consumption during the last 40 years, driven primarily by growing steel production in China as infrastructure has been expanded (IEA 2018).

According to (IEA 2018), in 2017 the global trade (exports) of coking coal was estimated at 327 million tonnes, equal to 24% of total hard coal trade (1,370,000 kt), of which 275 million tonnes represent seaborne trade (Euracoal 2018). Australia is the largest exporter in the global coking coal market, with a share of about 54% (177,000 kt) of total exports in 2017 (IEA 2018). Other important exporting countries are the USA, Canada, Mongolia, and Russia (see Figure 106). China, the world's largest producer, does not export coking coal as it is consumed domestically. Moreover, China imports significant amounts of high-

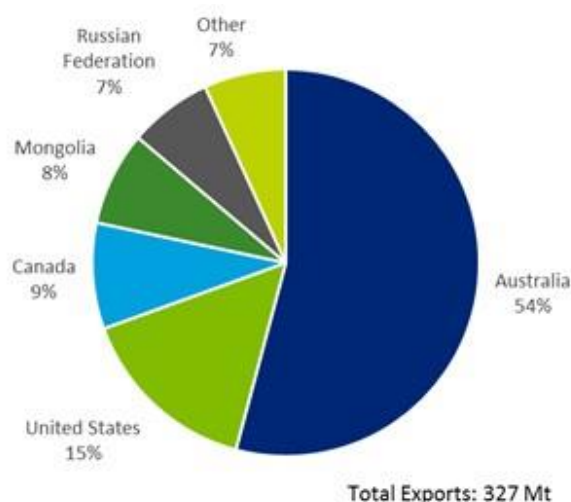
---

<sup>72</sup> [https://ec.europa.eu/clima/policies/strategies/2050\\_en](https://ec.europa.eu/clima/policies/strategies/2050_en)

<sup>73</sup> Estimation based on an average price of EUR 145 per tonne in 2017 (Australian hard coking coal) and the reported global production.

quality coking coal. In fact, the selection of coal types depends both on the desired coke quality and the final metal product quality. Also, coking coal produced in India has in some cases undesired quality for use in ironmaking (Sundqvist Ökvist et al. 2018). China does however export metallurgical coke, being the top exporter in the world (data for HS 270400 from (UN Comtrade 2019)). The value of coking coal traded globally was roughly estimated at EUR 47 billion<sup>74</sup> in 2017.

According to 2017 data (Euracoal 2018) (IEA 2018), the seaborne coking coal accounts for around one-quarter of the total world market with the remaining three-quarters consumed within domestic markets, e.g. China and India, and it best represents the international market for coking coal (Eurofer 2019b). The seaborne coking coal market is characterised by the smaller number of supplying countries in comparison to the steam coal market (Euracoal 2019).



**Figure 106: Major coking coal exporters worldwide in 2017. Data from (IEA 2018)**

It has to be noted that the coking coal supply chain has high exposure to disruptions such as adverse weather conditions and accidents due to the concentrated supply structure, i.e. number and geographical location of mining areas, capacity and location of ports and railways dedicated to exports (WorldSteel 2019b).

China's production of coking coal was subject to an export tax of 3% (decreased from 10% in 2015) as listed by the OECD Inventory for the year 2017 and the code HS 270112 "Bituminous coal, whether/not pulverised but not agglomerated" (OECD 2019a). A 3% fiscal tax on exports is imposed by Mongolia for coking coal concentrates, and a captive mining restriction by India. The above countries accounted for 60% of the global production of coking coal in 2017. Severe trade-restrictive measures (i.e. export taxes, export quotas, export prohibition) do not apply for coke in 2017 (OECD 2019a).

### 8.2.2 Outlook for supply and demand

The future worldwide demand for steel drives the market outlook for coking coal demand. A recent report (Commodity Insights 2018) prepared for the Minerals Council of Australia forecasts that the global import demand of metallurgical coal will grow by a rate of 2.3% from 2017 to 2030, representing an annual average growth of 7,5 Mt, mainly driven by strong demand for steel in India (60% increase of import demand) and China (39%

<sup>74</sup> Estimation based on an average price of EUR 145 per tonne in 2017 (Australian hard coking coal).

increase of import demand). The global demand for steel is expected to rise for many years (OECD 2019b), and primary steel production through the BF/BOF route will continue to play an important role in the future (EUROFER 2015).

On the supply side, China is expected to maintain its dominance in the producers' market, with coking coal production increasing from 540,000 kt in 2017 to 551,000 kt by 2028 (IEA 2018). S&P Global estimated an increase of Australian production 182,000 kt in 2018 to 214,000 kt by 2025 due to incoming new supply (S&P Global Market Intelligence 2018). Apart from the significant expansions in the already dominant market players, strong growth potential is reported for Mozambique and Mongolia (Euracoal 2019). Mining supply in the EU will decrease, as hard coal mining in Germany ended at the end of 2018. In 2017, Germany produced 2.3 million tonnes of coking coal (WMD 2019).

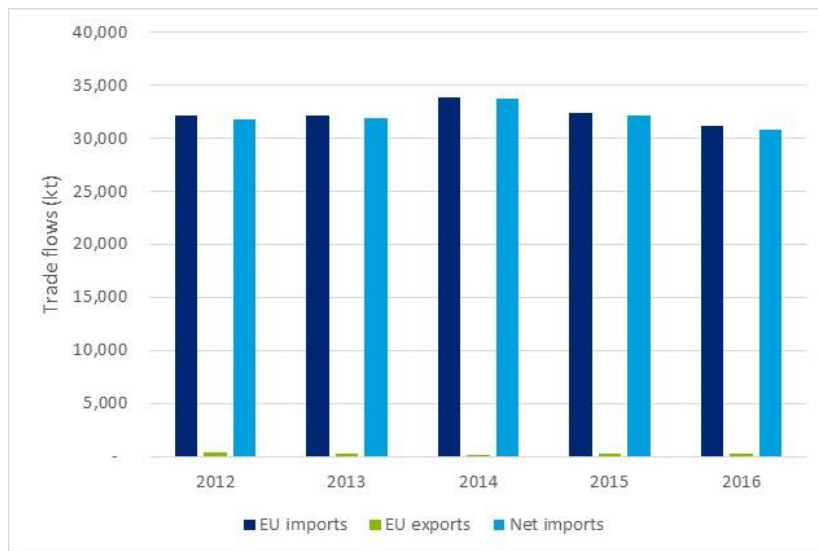
Available reserves of coking coal can strongly modify the future supply conditions as increasing quality and cost-benefit aspects may reduce the available volumes of the coking coal (HCC and Premium HCC qualities) necessary for maintaining high environmental performance and market competitiveness. Not all identified and potential deposits of coal can deliver high-quality coking coal. As with all mineral resources, the geographical location of currently active mines and the accessibility of known deposits influences the final cost of the extracted raw material, periodically making the exploitation of marginal deposits unfeasible (Eurofer 2019b).

**Table 44: Qualitative forecast of supply and demand of coking coal**

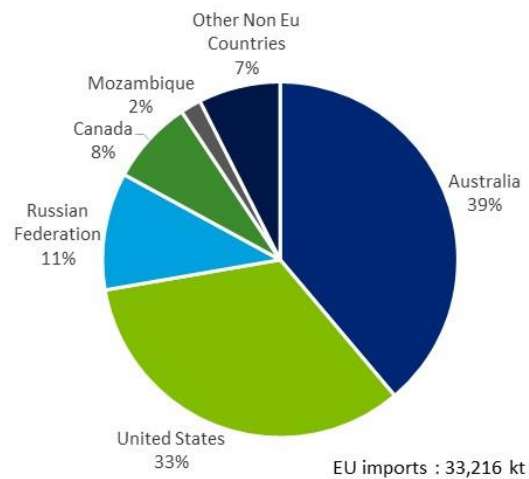
Material	Criticality of the material in 2020		Demand forecast			Supply forecast		
	Yes	No	5 years	10 years	20 years	5 years	10 years	20 years
Coking coal	X		+	+	+	+	+	?

### 8.2.3 EU trade

The EU has historically been a net importer of coking coal because demand from the steel industry exceeds domestic supply (European Commission 2017). Imports have remained relatively steady throughout 2012-2016 at around 33,216 kt per year on average, with a moderate increase to 33,854 kt in 2014, and a modest decrease to 31,121 kt in 2016 (Figure 107). The former can be linked to an increased domestic steel output in the Blast Furnace (BF)/Basic Oxygen Furnace (BOF) route in 2014 by about 3%. The latter is coupled with a decreased domestic production of about 2,100 kt in 2016 in comparison to 2015, as well as with increased coke exports (see Figure 109); The EU crude steel output from the BF/BOF route was stable in 2016 compared to 2015 (Worldsteel 2018). Most of the coking coal imported to the EU originates from Australia and the US (Figure 108). As an average in 2012-2016, the United States and Australia exported into the EU the 72% of all imported coking coal. Therefore, the EU relies on highly concentrated deposits for its imports of coking coal. In the same period, exports of coking coal remained minor at the level of a few hundreds of tonnes, representing around 1% of imports by volume.

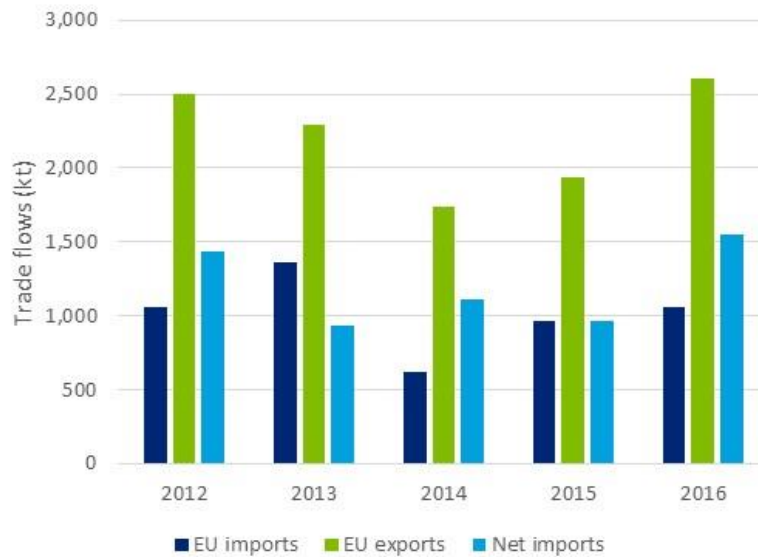


**Figure 107: EU trade flows for coking coal (ESTAT Comext 2019)**

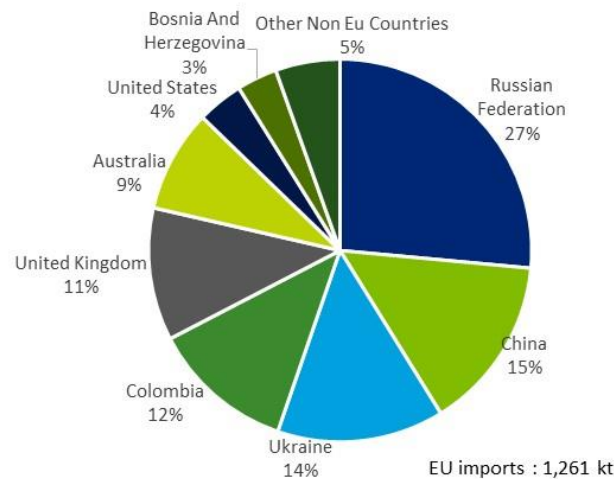


**Figure 108: EU imports of coking coal, average 2012-2016 (ESTAT Comext 2019)**

The EU is a net exporter of coke (Figure 109), exporting on average over the 2012-2016 period 2,214 kt and importing 1,261 kt annually (ESTAT Comext 2019). Imports of coke to the EU come mainly from Russia (see Figure 110).



**Figure 109: EU trade flows for coke (ESTAT Comext 2019)**



**Figure 110: EU imports of coke, average 2012-2016 (ESTAT Comext 2019)**

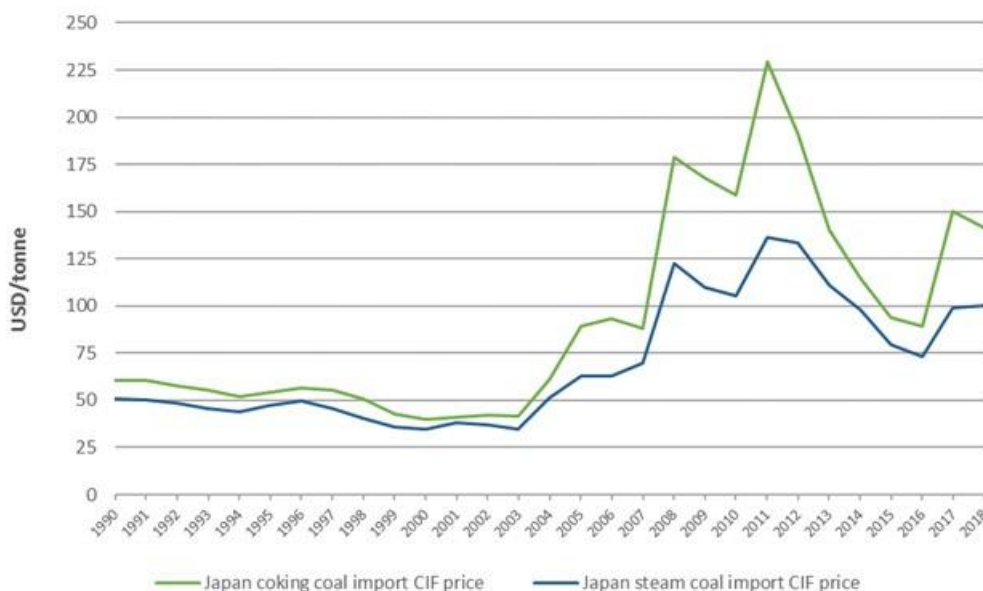
In 2017, countries exporting coking coal or coke to the EU did not apply restrictive export measures, i.e. export taxes, export quotas or export prohibitions (OECD 2019a). Free Trade Agreements exist with Canada, Colombia, Ukraine, United States and Bosnia and Herzegovina (European Commission 2019)

### 8.2.4 Prices and price volatility

Coking coal is traded both through contracts and in the spot market. Coal spot prices can fluctuate based on short-term market conditions, but contract prices tend to be more stable (US EIA 2019). Coking coal varies in quality, with hard coking coal representing the highest grade, which attracts a premium price. Semi-soft or high-volatile coking coal is of lower quality and as such, is sold at a lower price. Other essential price factors are freight, insurance, and whether the price refers to contracted coal or spot price (CRM Alliance 2018). Coking coal is more expensive than steam coal used in power plants due to the requirement of more thorough cleaning and low impurity level (US EIA 2019). Coke prices

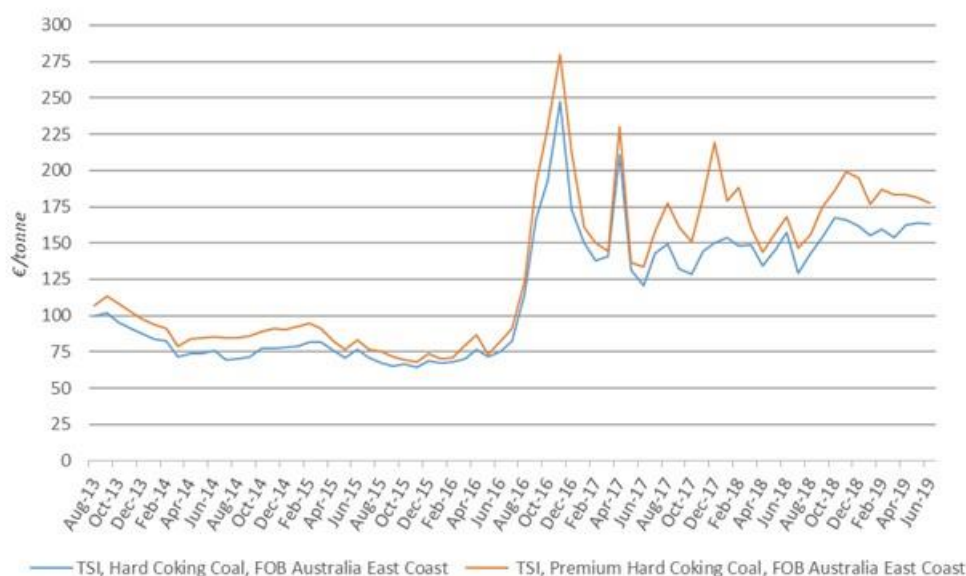
are correlated with coking coal prices, though higher at a level estimated roughly of 1.5 to 2 times (data from (JSW 2019b)).

The pricing of coking coal after a long period of substantial stability and low prices ranging from USD 40/tonne to 60/tonne on a yearly basis, started to sharply increase after 2003 due to the growing demand from emerging economies. In particular, the strong demand for steel from China due to large infrastructure projects supported and continues to support high prices for coking coal (Eurofer 2019b). The time series in Figure 111 reveals the sharp rise of the annual coking coal prices from USD 42/tonne in 2003 to USD 230/tonne in 2011, as well as the difference with steam coal prices.



**Figure 111: Developments in annual prices of steam coal and coking coal. Data from (BP 2019)**

Following the global recession in 2011, coking coal prices had a declining trajectory for many years. In summer of 2016, there has been a sharp rise in prices, which climbed to record highs at the end of 2016. While the monthly average spot price for Australian premium coking coal was still at USD 92/tonne in July 2016, it rose sharply to USD 309/tonne in November 2016 (see Figure 112). In 2017 and 2018, coking coal prices remained very volatile with several drops and spikes but remained at a relatively high average level. On a year-over-year basis, the annual average of the industry benchmark price (high-quality Australian hard coking coal tracked by the Steel Index) increased 65% in 2016, 28% in 2017 and 7% in 2018; in the first semester of 2019 the benchmark spot price is averaging over USD 200/tonne for (S&P Global Market Intelligence, 2019a).

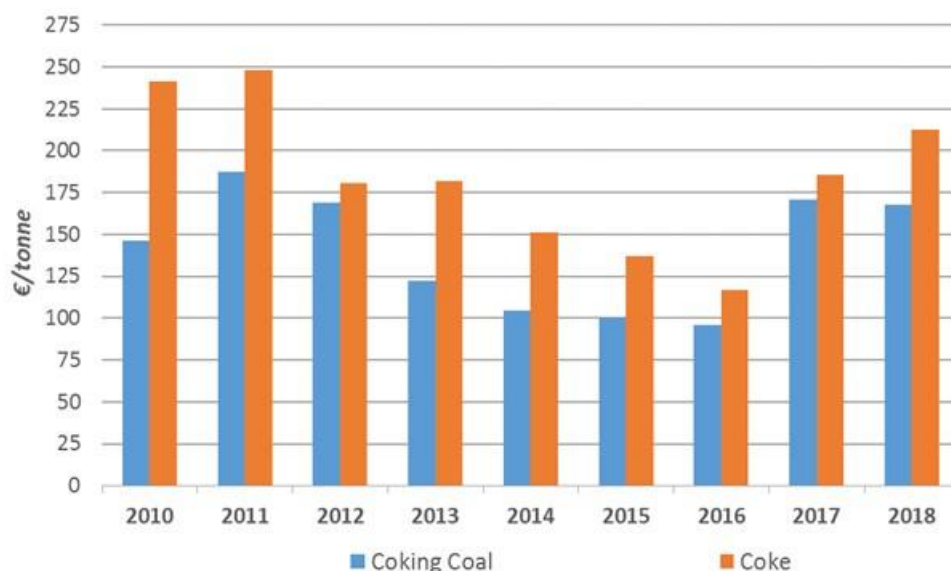


**Figure 112: Coking coal spot prices (The Steel Index), FOB Australia East Coast, monthly average (EUR/tonne). Data from (S&P Global Market Intelligence 2019a)**

The significant volatility in the 2017-2018 period can be attributed to higher demand from China and India, as well as by short-term increase of demand in other markets, but mostly to supply-side factors, e.g. severe supply bottlenecks in Australia caused by floods and cyclones which restricted shipments due to low train availability (Euracoal 2018) (Deloitte 2018) (CRU 2018)(S&P Global Market Intelligence 2019b). Similar weather-related supply disruption events influencing the pricing of coking coal occurred in the Australian mining region of Queensland in 2009 and 2011 (Eurofer 2019b).

The higher coal prices since 2016 mark the end of the previous period of oversupply (BGR 2017). A large degree of volatility is expected to be maintained in the short term, due to the rise in global demand and the relatively low amount of investment in exploration and the development of new coal projects (BGR 2019a).

Figure 113 presents the evolution of unit value for imports of coking coal and coke in the EU. After a five-year decline, in 2016 the annual average unit value for imports of coking coal was EUR 96/tonne, and EUR 117/tonne for imports of coke and semi-coke of coal. In 2017, the annual average unit value for imported coking coal rose by around 80% at EUR 171/tonne, and remained at high levels in 2018. The annual average unit value for imported coke and semi-coke of coal increased by about 60% in 2017 to EUR 186/tonne, and in 2018 by 15% on a year-on-year basis at EUR 213/tonne.



**Figure 113: Unit value<sup>75</sup> of EU imports of coking coal and coke/semi-coke of coal, yearly average (EUR/tonne). Data from (ESTAT Comext 2019)**

## 8.3 EU demand

### 8.3.1 EU consumption

The EU apparent consumption of coking coal is calculated at approximately 53,548 kt in volume as an average for the period 2012-2016. Of this, about 20,332 kt per year came from within the EU (calculated as EU production – exports to non-EU countries) and 33,216 kt were imported. Based on these figures, the net import reliance is 62%. The annual EU apparent consumption of coke is calculated at 35,553 kt for the same period. The EU is not import reliant as it is a net exporter of coke.

The EU apparent consumption of coking coal declined by 10% from 2012 to 2016, from 54,152 kt in 2012 to 48,915 kt in 2016, mainly due to declining domestic production from 22,393 kt in 2012 to 18,102 kt in 2016 (ESTAT Comext 2019)(WMD 2019). In the same period, the EU coke consumption was relatively stable, ranging from 35,800 to 34,800 kt.

It has to be noted that the aforementioned consumption levels of coking coal and coke include the use of PCI in the blast furnace (see Section 8.3.3), and PCI injection has already reached its technical limits in the EU industry (Eurofer 2019a).

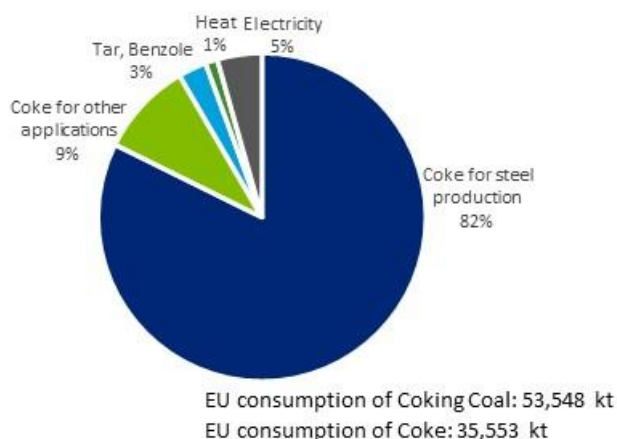
### 8.3.2 Uses and end-uses of coking coal in the EU

The use of coking coal in the steel making process is the most significant application. 90% of coke is used in the iron making process (blast furnace) for generating the necessary

<sup>75</sup> For coking coal, the imports unit value is calculated for the trade code CN 27011210 “Coking Coal, whether or not pulverised, but not agglomerated”. For coke/semi-coke of coal, the imports unit value is considered for the combined quantity and value for trade codes: CN 27040010 ‘Coke and semi-coke of coal, whether or not agglomerated’, CN 27040011 ‘Coke and semi-coke of coal, whether or not agglomerated, for the manufacture of electrodes’, and CN 27040019 ‘Coke and semi-coke of coal, whether or not agglomerated (excl. For the manufacture of electrodes)’. Semi-coke is a different product from coke formed by incomplete carbonisation of coke. However, trade data for coke and semi-coke are aggregated



process heat, as a reduction medium of iron ores, carburisation of the hot metal, supporting the furnace charge, and providing permeability inside the furnace. More than 70% of world steel production is made by the integrated steelmaking route which is based on the blast furnace (BF) and basic oxygen furnace (BOF) processes, and therefore, relies on coking coal (World Coal Association 2019)(World Coal Institute 2009). In the EU, 60% of steel production, which requires coking coal, is produced via the blast furnace route (European Commission 2018). The average production of one tonne of steel in the integrated steelmaking process requires the use of 630 kilograms of coke, and therefore 780 kilograms of coking coal (WorldSteel 2019a) (World Coal Institute 2009).



**Figure 114: EU end uses of coking coal (average 2013-2017) (IChPW 2019) and EU consumption of coking coal and coke (average 2012-2016) (Eurostat Comext 2019)(WMD 2019)**

According to data from (BIO Intelligence Service 2015) 1% of coking coal is used in the manufacture of electrodes generally intended for the metallurgical industry, and tar is an essential source material. Coking coal is also used in the production of foundry coke employed in foundry melting furnaces by some producers of base metals and ferroalloys (FeMn and FeCr). Other minor users of metallurgical coke are producers of non-metallic minerals such as phosphates, calcium carbide, soda ash and stone wool, or as a household heating fuel.

Several products can be produced from by-products (coke oven gas, benzole, coal tar, ammonia sulphate and sulphur) of coke ovens. Ammonia gas recovered from coke ovens is used to manufacture ammonia salts, nitric acid and agricultural fertilisers, while refined coal tar is employed in the manufacture of chemicals (e.g. creosote oil, naphthalene, phenol, and benzene) as well as in carbon fibres (World Coal Association 2019) (Remus et al. 2013) (Ozon 2018) (Diez, Alvarez, and Barriocanal 2002) (JSW 2019a). Benzole (benzene, toluene, xylene) is also used in the chemical industry, whereas coke oven gas can be used for heat and power generation as it contains almost 55% of hydrogen (IChPW 2019).

Relevant industry sectors are described using the NACE sector codes (Eurostat 2019). The calculation of economic importance is based on the use of the NACE 2-digit codes and the value added at factor cost for the identified sectors (Table 45). The value-added data correspond to average 2012-2016 figures.

**Table 45: Coking coal applications, 2-digit and examples of associated 4-digit NACE sectors, and value-added per sector (IChPW 2019)(SCRREEN workshops 2019)(Eurostat 2019)**

Applications	2-digit NACE sector	Value-added of the sector (millions EUR)	Examples of 4-digit NACE sector(s)
Coke for steel production	C24 - Manufacture of basic metals	55,426	C24.10 - Manufacture of basic iron and steel and of ferro-alloys
Coke for other applications	C23 - Manufacture of other non-metallic mineral products	57,255	C2399 - Manufacture of other non-metallic mineral products n.e.c
Other uses (tar, benzole, electricity and heat)	C20 - Manufacture of chemicals and chemical products	105,514	C20.14 - Manufacture of other organic basic chemicals -Distillation of coal tar C20.15 - Manufacture of fertilizers and nitrogen compoundsammonia

### 8.3.3 Substitution

Currently, there are no technologically feasible and economically reasonable alternatives to completely replace coking coal in the production of steel from iron ore (Eurofer 2019b). The main reason is that metallurgical coke in the blast furnace charge supports the iron ore burden and provides a permeable matrix necessary for slag and metal to pass down into the hearth and hot gases to move upwards into the stack (European Commission 2017)(SCRREEN workshops 2019).

Coking coal (coke) can be replaced by pulverised coal (PCI) up to a certain level, which then requires the remaining hard coking coal to be of higher quality, mainly premium hard coking coal, otherwise the performance of steel production process can be strongly lowered (Eurofer 2019b). About 30% of coal can be saved by injecting fine coal particles into the blast furnace as one tonne of PCI coal used for steel production can replace about 1.4 tonnes of coking coal by reducing the amount of coke required. Coals used for pulverised coal injection into blast furnaces have more narrowly defined qualities than steam coal (WorldSteel 2019a). PCI coal is mainly used to achieve cost benefits by replacing coke, thus skipping the costly coke-making stage. Pulverised coal injection is a technique widely applied in the EU (Addendum in Pardo, Moya and Vatopoulos, 2015), and the industry has already reached the technical limits for coke substitution (Eurofer 2019a). For this reason, PCI does not affect the substitution index of coking coal in the criticality assesment. A 30% substitution of coking coal with PCI was assumed in the EU MSA study of coking coal (background data from (BIO Intelligence Service 2015)).

In addition, for some production processes, natural gas may substitute for as much as 10% of coking coal (Eurofer 2019b). Natural gas is a reducing agent in the production of Direct Reduced Iron (DRI) from iron ore, an alternative production route for crude steel. However, this technology is not common in Europe (Pardo, Moya, and Vatopoulos 2015). In the EU, only 700 kt of DRI was produced in 2017 (Worldsteel 2018), corresponding to less than 1% of the EU total iron production, as the technology is not commercially viable due to the high cost of gas (Eurofer 2019a).

Different methods have been explored to enable the use of coals with lower quality in the coking process without undermining coke quality. These are for example: the stamp charging technology with oil additives, the "Scope 21" coke-making process in Japan using high blending ratio (over 50%) of non- or slightly-coking coal, the use of hypercoal as additive to coking coal blend (Tercero et al. 2018) (Sundqvist Ökvist et al. 2018). The cost

for hypercoal is higher, but it enables the use of some thermal coals (CRM experts 2019). Waste plastics in coking coal blend is also an alternative that can replace the use of 1-2% of coking coal (Tercero et al. 2018). However, as less suitable coking materials significantly influence coke quality, it is possible to use only low amounts of secondary materials in the coking process (Sundqvist Ökvist et al. 2018). It is estimated that economically favourable alternatives (such as hypercoal and waste plastics) can be used to substitute 5-10% of coking coal for metallurgical applications (Tercero et al. 2018).

Other materials, such as hydrogen and natural gas potentially used in the blast furnace are not substitutes of coking coal *per se* as they do not provide mechanical support to the charge of the blast furnace nor the necessary carbon monoxide (CO) for reducing the iron ore, but perform only the function of delivering heat (CRM experts 2019). However, in the future, specific processes may substitute coking coal with natural gas, hydrogen and biomass, e.g. Hisarna process (Pardo, Moya, and Vatopoulos 2015).

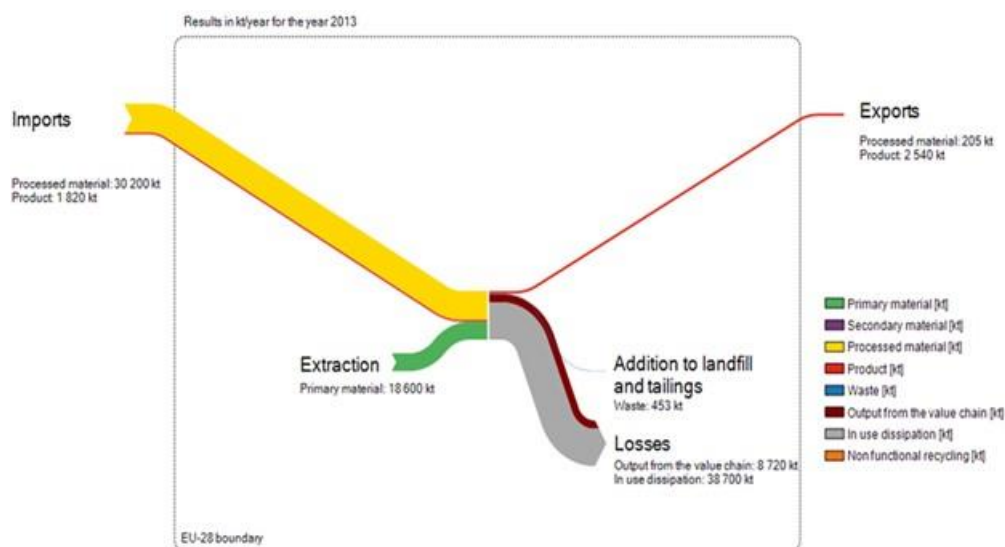
Fines of coke (coke breezes), which are used in the sintering of iron fines, can be substituted by ultra-grade anthracite. Also, part of the coke can be replaced in the blast furnace by anthracite as a heat source (CRM experts 2019).

For the production of electrodes, natural graphite and synthetic graphite can replace effectively coking coal (Tercero et al. 2018)(Sundqvist Ökvist et al. 2018).

## 8.4 Supply

### 8.4.1 EU supply chain

Figure 115 shows the coking coal flows (in C content) through the EU economy.



**Figure 115: Simplified MSA of coking coal flows in the EU. 2013. (BIO Intelligence Service 2015)**

#### 8.4.1.1 EU sourcing of coking coal

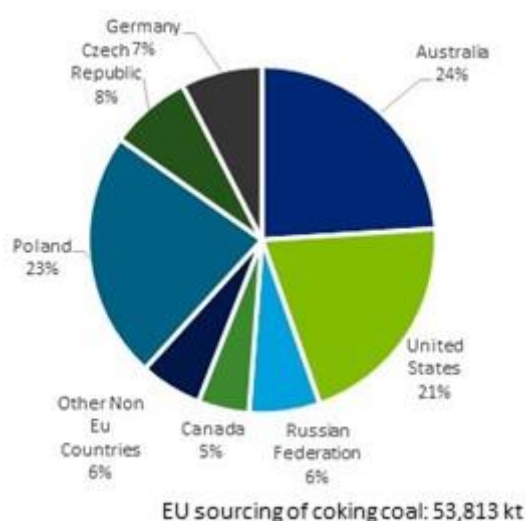
EU sourcing of coking coal amounts to 53,813 kt (domestic production + imports). The annual average EU production of coking coal over 2012-2016 was 20,597 kt. Over the same period, coking coal was produced in Poland, Czechia and Germany. The EU production declined by 20% from 2012 to 2016, mainly due to decreased production from Czechia and Germany;(WMD 2019); in Germany, production ended in 2018. EU domestic production covered 38% of its needs.

In 2017, around 25% of the active hard coal mines in the EU produced metallurgical coal (and anthracite). In particular:

- In *Poland*, 18 hard coal mines were active in the Silesia (Śląskie) region, with 27% of coal produced in this region classified as coking coal;
- In *Czechia*, hard coal is mined at two underground mines located in the Moravskoslezsko region (Karviná and Darkov, ČSM), in which the extracted coal is graded as coking coal or steam coal based on its quality parameters. In the same region, the Paskov mine, with 89% of coal produced classified as coking coal, terminated its production in 2017;
- In *Germany*, two remaining underground hard coal mines produced steam coal and coking coal in 2016, the Prosper-Haniel mine, and the Ibbenbüren mine located in the Münster region (P. Alves Dias et al. 2018)(Euracoal 2017). Those mines were active only till the end of 2018. Therefore, Germany does not any longer contribute to the EU coking coal supply side.

In total, the share of coking coal in the overall EU hard coal production was on average 21% for the period 2012–2016. In Poland, coking coal accounted for 17% of hard coal production, while the share of coking coal in the overall hard coal production in Czechia and Germany 2017 was 50% and 56% respectively (WMD 2019).

Despite domestic production, the EU remains dependent on imports of coking coal, with net import reliance of 62%. The majority of coking coal imported to the EU comes from the USA and Australia, which cover 24% and 21% of the total EU supply respectively (see Figure 116). Due to the closure of mines in Germany, the EU import reliance will increase from 2019 onwards. In case the annual average production of 4,060 kt from Germany in the reference period 2012-2016 is replaced entirely by imports, and assuming that the apparent consumption remains constant, then the EU net import reliance would increase to 69%.



**Figure 116: EU sourcing of coking coal. Average 2012-2016 (WMD 2019) (ESTAT Comext 2019)**

#### 8.4.1.2 EU sourcing of coke

EU sourcing (domestic production + imports) of coke amounts to 37,660 kt. The annual average EU production of coke over 2012-2016 was 36,506 kt (VDKI 2017). Coke is produced in 13 Member States. EU production covers 100% of domestic consumption.

In 2017, around 60 % of the EU crude steel production took place in integrated steelmaking plants (Blast furnace/Basic Oxygen furnace process), in which coke oven plants are typically an operational unit. Coking coal can also be converted into coke in individual coking plants before marketing to the iron industry. For example in Poland, the

major producer of coking coal in the EU, coke is produced at the Przyjaźń and Zabrze coking plants operated by the mining company JSW (JSW 2019a).



**Figure 117: EU sourcing of coke. Average 2012-2016 (VDKI 2017) (ESTAT Comext 2019)**

## 8.4.2 Supply from primary materials

### 8.4.2.1 Geology, resources and reserves of coking coal

**Geological occurrence:** Coal is a combustible, carbonaceous sedimentary rock, which is composed of fossilised plant remains, minerals and water. Coal is formed as accumulated dead plant materials in swamp ecosystems are buried beneath layers of younger sediments and altered by the combined effects of pressure and heat over millions of years to form individual carbon-rich coal layers, known as seams. The characteristics of coals are determined by the coalification process (e.g. varying types of buried vegetation, depths of burial, temperature and pressure at those depths, time of coal deposit formation). The composition and the amount of impurities (e.g. sulphur and phosphorous), the content of volatile matter and ash strongly condition the possible uses of the coal. For that reason, different groups and sub-groups of coal are identified, and each of them is used for specific purposes only. The most common classification of coals is based on rank, which represents the degree of coalification that has occurred. Classification of coals by rank ranges progressively from brown coals, which include lignite and sub-bituminous coal, to black or hard coals that comprise bituminous coal, semi-anthracite and anthracite. Anthracite (most carbonaceous) is classified as high-rank while lignite (least carbonaceous) is classified as low-rank. Coal types can be differentiated in the ranking sequence by several properties, e.g. elemental composition, volatile matter content, fixed carbon content, calorific value, water content, etc.; many different classification systems have been developed on a national and international level. Coking coal is classified as medium-rank bituminous coal which contains more carbon, less moisture and ash than low-rank coals. Coking coals usually have a volatile matter yield between 20% and 30% (dry, ash-free basis) (BGS 2010)(World Coal Association 2019)(World Coal Institute 2009)(Eurofer 2019b) (European Commission 2012).

The properties of coking coal have to be more tightly controlled than steam coal used in power stations and other uses, given the major impact of coke on blast furnace operation and pig iron composition. The required properties for coking coal to be suitable for steelmaking are low ash, sulphur and phosphorus content, as well as the ability to soften, swell and then solidify into a porous material of high strength when heated to a sufficiently

high temperature in the absence of air (caking ability). A coal's caking properties are the primary determinant of its suitability for coke production (BGS 2010)(World Coal Association 2019)(World Coal Institute 2009).

**Global resources and reserves:** Many different national and international definitions and classifications exist to subdivide coal resources into different classes, e.g. hard coal, brown coal, steam coal, coking coal, etc. These subdivisions are either based on scientific (physical, chemical, petrographic), technical (heating value, plasticity, swelling index), commercial, or combined parameters. As different definitions and cut-off values are used to subdivide the volumes of coal resources and reserves, e.g. into brown coal and hard coal, the resulting figures are not comparable (European Commission 2012). There are no resource and reserve data on coking coal at the national/regional level reported using the United Nations Framework Classification (UNFC)(European Commission 2017).

However, bituminous coal reserves can be a rough indication of raw materials suitable for extracting coking coal. The known reserves of anthracite and bituminous coal were approximately 718 billion tonnes at the end of 2017 (BP 2018), sufficient to meet the demand for centuries. The United States has the world's largest reserves, followed by China and India (Table 46).

**Table 46: Global proved reserves<sup>76</sup> of anthracite and bituminous coal at the end of 2017 (Data from (BP 2018))**

Country	Bituminous coal and anthracite reserves (billion tonnes)	Percentage of the total (%)
US	220.8	30.7%
China	130.8	18.2%
India	92.8	12.9%
Russian Federation	69.6	9.7%
Australia	68.3	9.5%
Ukraine	32.0	4.5%
Kazakhstan	25.6	3.6%
Poland	19.8	2.8%
Indonesia	15.1	2.1%
South Africa	9.9	1.4%
Others	33.5	4.7%
Total world	<b>718.3</b>	100%

**EU resources and reserves<sup>77</sup>:** There are no published data on coking coal resources and reserves using the United Nations Framework Classification (UNFC). Reserves of 22 billion tonnes of anthracite and bituminous coal are reported in the EU, the majority of them is located in Poland (see Table 47) mostly in the Upper Silesian basin (79% of the total hard coal reserves in Poland) where 27% of the hard coal reserves consists of coking coal (Eurocoal 2017). Other than the resource estimation reported in Minerals4EU website, deposit of antimony was reported in Rockliden, Sweden at 10 Mt with 0.18% Sb, (also contains 4.03% Zn, 1.82% Cu, 52 ppm Ag, 0.06 ppm Au) (Depaux, G., 2019).

<sup>76</sup> Generally taken to be those quantities that geological and engineering information indicates with reasonable certainty can be recovered in the future from known reservoirs under existing economic and operating conditions. The data series for total proved coal reserves does not necessarily meet the definitions, guidelines and practices used for determining proved reserves at the company level.

<sup>77</sup> The Minerals4EU project is the only repository of some mineral resource and reserve data. However, there are no data for coking coal in the Mineral4EU website, for both resources and reserves in Europe.

**Table 47: EU total proved reserves<sup>78</sup> of anthracite and bituminous coal at the end of 2018 (Data from (BP 2019))**

Country	Bituminous coal and anthracite reserves (billion tonnes)
Poland	20,542
Spain	868
Hungary	276
Bulgaria	192
Czechia	110
Romania	11
Germany	3
Total EU	<b>22,002</b>

**Exploration and new mine development projects in the EU:** In Poland, there are two ongoing new mine development projects in progress (Prairie Mining 2019):

- The *Jan Karski* project in the Lublin coal basin. The project has a potential to produce thermal and semi-soft coking coal. JORC-compliant total resources amount to 728 Mt of in-situ coal and probable ore reserves are estimated at 139.1 Mt of marketable coal, and the annual production can yield 6.3 Mt of marketable coal. The results of a pre-feasibility study were announced in March 2016.
- The *Debiensko* project in Upper Silesian coal basin. The project aims to produce premium hard coking coal (mid-vol and low-vol HCC). Resources reported under the JORC code comprise a total resource of 301 Mt of in-situ coal, and annual production is projected at 68 Mt of saleable coal over a 26 year period. A scoping study was published in March 2017.

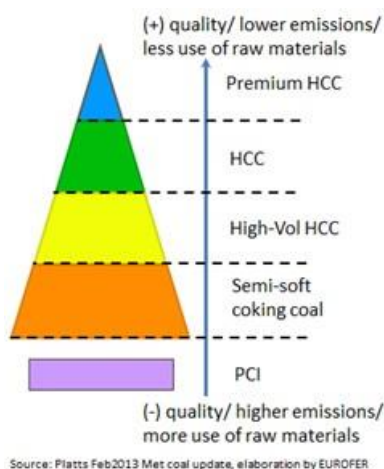
#### **8.4.2.2 Production of coking coal**

Coal is mined by open-pit or underground methods, depending on the morphology of the coal deposit. Surface mining is applied when the coal seam is near the land surface (BGS 2010). Before marketing, Run-of-mine coal is upgraded in preparation plants where the extracted hard coal is graded as coking coal or steam coal, based on certain quality parameters. Preparation may include washing, crushing, sieving, and gravity concentration to satisfy size and purity specifications of the intended use.

The use of coking coal for metallurgical applications, i.e. steel production, require that certain physical and chemical properties are tested in advance in order to check the complete compatibility of the raw material with the production process (i.e. CSR index – coke strength after reaction). Moreover, also the content on impurities like sulphur and phosphorus, and not only, impose in which industrial processes the coking coal can be used. For this reason the coking coal is subdivided in different products: Premium Hard Coking Coal (PHCC), Hard Coking Coal (HCC), High-Volatile HCC (Semi-HCC), Semi-soft coking coal (SSCC), Low Vol PCI, each of them identified by different properties and performance when employed in the industrial processes. In general, the EU steel production should be fed using Premium HCC and HCC for maintaining the high environmental performance of the installations (i.e. higher quality HCC means the use of less raw materials and lower emissions). In particular, the European integrated steel process routes uses the most advanced technologies using PHCC and HCC only, in

<sup>78</sup> Generally taken to be those quantities that geological and engineering information indicates with reasonable certainty can be recovered in the future from known reservoirs under existing economic and operating conditions. The data series for total proved coal reserves does not necessarily meet the definitions, guidelines and practices used for determining proved reserves at the company level.

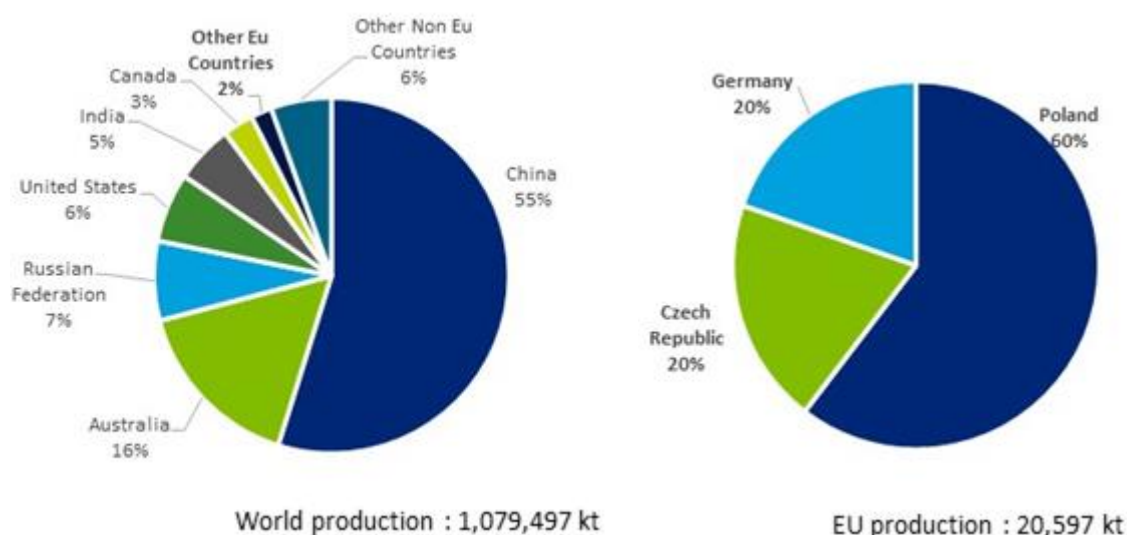
compliance with European environmental laws. Any substantial substitution of these high-quality coking coals will surely increase the whole environmental impact (Eurofer 2019b).



**Figure 118: Coking coal products (European Commission 2014)**

### 8.4.2.3 World and EU mine production of coking coal

The annual world supply of coking coal was about 1,079,497 kt as an average between 2012 and 2016. As can be seen in Figure 119, China was by far the biggest producer of coking coal globally, producing 55% of the world’s total. Other significant producers are Australia (16%), Russia (7%) and the United States (6%). The overall EU production of coking coal accounted for 2% of world production. The European production of coal was about 20.597 kt. 60% of the EU output was mined in Poland, whereas Germany and the Czech Republic contributed to 20% each over the years 2012-2016.



**Figure 119: Global and EU mine production of coking coal. Average for the years 2012-2016. (WMD 2019)**

### 8.4.3 Processing of coking coal

Coking coal is converted into coke, semi-coke and coke by-products in coke ovens. Coke making, or carbonisation, entails heating the coal to high temperatures (1,150 to 1,350

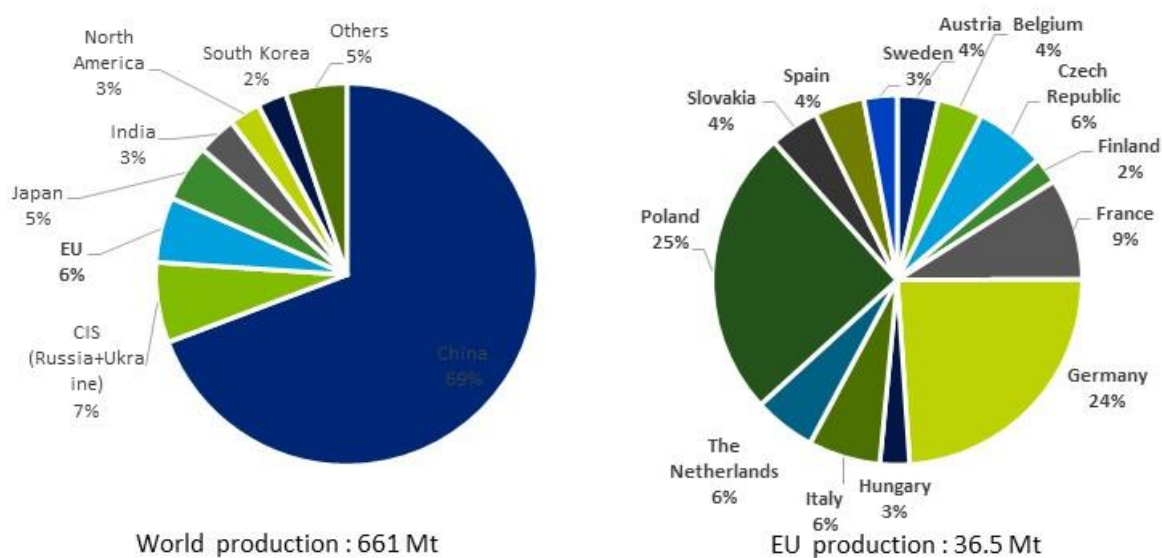


°C) in the absence of oxygen to drive off gases and impurities and concentrate the carbon content (Remus et al. 2013). Semi-coke is formed by incomplete carbonisation of coal, with a reduced air supply, at a temperature of between 450 and 700 °C.

Before coke making, selected bituminous coal grades are usually blended and pulverised to control the size and quality of the feed. During heating, the physical properties of coking coal allow the coal particles to pass through softening, fusing, and solidification into hard and porous coke lumps. They are then quenched with either water or air before storage or direct transfer to the blast furnace. Exhaust gases are collected and processed to recover combustible gases for heat production and other by-products (Remus et al. 2013)(Diez, Alvarez, and Barriocanal 2002). The coke yield varies from 700 kg to 800 kg of dry coke per tonne dry coal (approximately 1250-1400 kg coking coal is needed for the production of 1 tonne of coke depending on the volatile content), and the coke oven gas production ranges from 140 kg to 200 kg per tonne dry coal. The yield of tar and benzole (benzene, toluene, xylene) is reported to be 50 kg per tonne dry coal (ICHPW 2019).

### 8.4.3.1 World and EU production of coke

The annual EU production of coke was around 36,506 kt as an average from 2012 to 2016. 13 Member States are listed as coke producers (VDKI 2017). Poland and Germany, with 25% and 24% respectively, have the highest share of EU production.



**Figure 120: World and EU coke production. Average for the years 2012-2016. Data from (VDKI 2017)**

### 8.4.4 Supply from secondary materials/recycling

Recycling is not applicable as coke is entirely dissipated after its use as it is oxidised to CO<sub>2</sub> (BIO Intelligence Service 2015). Therefore, the EOL-RIR is 0%.

**Table 48: Material flows relevant to the EOL-RIR of coking coal in 2013<sup>79</sup>. Data from (BIO Intelligence Service 2015a)**

MSA Flow	Value (tonnes)
B.1.1 Production of primary material as the main product in EU sent to processing in EU	18,117

<sup>79</sup> EOL-RIR=(G.1.1+G.1.2)/(B.1.1+B.1.2+C.1.3+D.1.3+C.1.4+G.1.1+G.1.2)

B.1.2 Production of primary material as by-product in EU sent to processing in EU	0
C.1.3 Imports to EU of primary material	0
C.1.4 Imports to EU of secondary material	0
D.1.3 Imports to EU of processed material	30,181
E.1.6 Products at end of life in EU collected for treatment	0
F.1.1 Exports from EU of manufactured products at end-of-life	0
F.1.2 Imports to EU of manufactured products at end-of-life	0
G.1.1 Production of secondary material from post-consumer functional recycling in EU sent to processing in EU	0
G.1.2 Production of secondary material from post-consumer functional recycling in EU sent to manufacture in EU	0

## 8.5 Other considerations

### 8.5.1 Environmental and health and safety issues

As an energy-intensive industry, the European steel industry accounted in 2016 for about 7% of the verified greenhouse gas emissions of all stationary installations of the European Union and around 22% of industrial emissions excluding combustion. Most of the emissions come from the iron ore reduction process, in which the carbon provided by the coke acts as the reductant. Reducing the carbon intensity of the blast furnace steelmaking route is, therefore, one of the two methods - the other is the increased share of the electric furnace steelmaking route- to decarbonise the steel industry. Among the novel technologies to achieve emissions reduction are carbon capture and storage, carbon capture and utilisation, hydrogen-based steelmaking, iron ore electrolysis. Currently, there are several innovative low carbon projects under development in the European iron and steel industry, with market entry forecasted within the next decade. Such breakthrough innovations will constitute an entirely new production system that would replace production processes that have been used and optimised for many decades. As an example, the hydrogen-based direct reduction process aims using hydrogen to completely bypass the use of coal for the production of primary steel (European Commission 2018). However, they are not going to be available in the next decade (IChPW 2019).

Imported coking coal to the EU has a higher carbon footprint. It is reported that EU-based production has lower carbon emissions by 1.5-3 times compared to coking coal imported from Australia due to maritime emissions (JSW 2019b) (IChPW 2019).

EU OSH requirements exist to protect workers' health and safety, employers need to identify which hazardous substances they use at the workplace, carry out a risk assessment and introduce appropriate, proportionate and effective risk management measures to eliminate or control exposure, to consult with the workers who should receive training and, as appropriate, health surveillance<sup>80</sup>.

### 8.5.2 Contribution to low-carbon technologies

By definition, the contribution of coking coal to low-carbon technologies is not applicable. Nevertheless, coking coal is an essential ingredient in steel production, and the importance of steel in all industrial sectors is beyond doubt. Steel is necessary for low-carbon technologies in the broad areas of transport (e.g. tower structures and associated concrete infrastructure, generators), wind power (e.g. for specific magnetic properties, and essential structural elements within wind turbines), solar power etc. (Euromines 2019). More information is available in the Iron Ore factsheet.

<sup>80</sup> <https://ec.europa.eu/social/main.jsp?catId=148>

Also, noteworthy is the use of products derived from the by-products of coke production in some innovative technologies. For example, carbon fibres produced from coal tar are used in aviation and automotive industry where they offer a great lightweight potential with benefits in fuel consumption but also for hydrogen storage tanks, where they provide the container to be hermetic, tight and meet all safety standards for hydrogen storage. While tanks are produced in Europe, carbon fibers are mostly imported from Asia. Moreover, in the case that hydrogen separation from coke oven gas is achieved, it can be used in fuel cells for zero-emission power generation and transport. JSW reports that the amount of hydrogen circulating in its coking plants is almost 75 kt annually which could fuel about 600 hydrogen-fuelled buses or over 4,000 hydrogen-fuelled cars. Another technology is carbon materials used in aviation, defence and electronics for their lightweight and durability, as well as in small amounts (1-3%) in graphite anodes of Li-ion batteries which are produced from needle coke (JSW 2019b).

Compared to the conventional oil-based needle coke, the coal-based needle coke has certain distinguishing characteristics, such as high heat durability and world's lowest thermal expansion rate (Mitsubishi Chemical Corporation 2019). Currently there are only four companies globally that produce this product of a high technology, mostly Japanese<sup>81</sup>. JSW estimates that its own capacity production of needle coke (own coal tar processing) would provide 10% of European demand for this processed material (JSW). Taking into account the proximity of other coal tar suppliers it would be possible for JSW to produce up to 60.000 tonnes of needle coke annually. Electrode applications are projected to grow at a high CAGR of 7.3% by 2025 and therefore global demand for needle coke is also estimated to grow over 5% annually in next 5 years (Grand View research, 2019). Meanwhile local production of coal tar is decreasing together with a decrease of coke production. This will cause not only a total dependence from import of coke for steel industry but also of those processed materials used for carbon fibers and in battery value chain.

### **8.5.3 Socio-economic issues**

Coking coal faces political, technical and financial challenges in the transition to a lower-carbon economy (CRM Alliance 2018). The decline in coal-related activities might also affect the iron and steel sector. Hard coal mines capable of producing this type of coal could continue to operate purely by serving this sector, as long as coking coal prices are sufficient enough to sustain mining operations (P. Alves Dias et al. 2018).

The level of governance of countries supplying coking coal to the EU is medium to high, except the Russian Federation providing 6% if the total EU sourcing. At the global level, more than half of the supply (55%) derives from a country with low governance, i.e. China. In this country, governance is deficient in the area of "Voice and accountability" (World Bank 2018).

The importance of coking coal mining in Europe is analysed in the report of the European Commission *EU coal regions: opportunities and challenges ahead* (2018) by the Joint Research Centre (JRC)(P. Alves Dias et al. 2018).

## **8.6 Comparison with previous EU assessments**

---

The assessment has been conducted using the same methodology as for the 2017 list. The calculations of the Supply Risk (SR) for 2014 and 2017 lists have been performed for the

---

<sup>81</sup> <https://www.televisory.com/blogs/-/blogs/can-lithium-ion-anode-demand-for-needle-coke-reduce-availability-for-electrode-players->

mine stage (coking coal). In the current assessment, the supply risk has been analysed at both the mine and the processing stage (coke). The results of the current and earlier assessments are shown in Table 49.

**Table 49: Economic importance and supply risk results for coking coal in the assessments of 2011, 2014, 2017, 2020. (European Commission 2011);(European Commission 2014); (European Commission 2017)**

Assessment	2011		2014		2017		2020	
Indicator	EI	SR	EI	SR	EI	SR	EI	SR
Coking coal	not assessed	not assessed	8.9	1.2	2.3	1.0	3.0	1.2

Coking coal was not assessed in 2011, and it was identified as critical in the 2014 assessment. The sharp decline of the economic importance results in the 2017 assessment is the result by the change in methodology, i.e. base metal was isolated from metal products on NACE 2-digit level, and the mega sector approach was discarded. This resulted in a lower overall value-added and thereby impacted the Economic Importance score for coking coal. In the 2017 assessment, although coking coal missed the economic importance threshold, for the sake of caution, it was kept on the list of critical raw materials for the EU<sup>82</sup>.

In the current assessment, the Supply Risk (SR) was calculated using both the HHI for global supply and EU supply as prescribed in the revised methodology. The results show that the supply risk is higher at the extraction stage (SR=1.19) than the processing stage (SR=0.34). The stage with the highest score has been considered as representing the overall supply risk for coking coal, i.e. SR=1.19 (rounded to 1.2). The SR appears increased in comparison to the 2017 assessment due to two reasons. Firstly, different substitute materials were considered for the substitution index in the current assessment in relation to the 2017 exercise. In particular, the use of PCI does not contribute to the substitutability of coking coal, as it is a widely applied technique by the EU steel industry which has already reached its technical limits. In the previous assessment the factor for PCI introduced in the calculation of the substitution index was 30%. Secondly, in the 2017 assessment, an erroneous allocation of EU production in the calculation formulas of the EU supply risk component resulted in lower supply risk by 0.1 (i.e. SR=1.0 instead of SR=1.1).

The Economic Importance (EI) indicator has increased due to the introduction in the calculation of the NACE 2-digit sector "C20 - Manufacture of chemicals and chemical products" of high value-added, and a lower share allocated to the NACE 2-digit sector "C24 - Manufacture of basic metals" of lower value-added.

## 8.7 Data sources

Production data of coking coal were sourced from 'World Mining Data' published by the Austrian Ministry for Sustainability and Tourism and the International Organising Committee for the World Mining Congress Austrian Ministry of Science, Technology and Commerce. The source of data for the production of coke was the German Coal Importers Association (VDKi). Eurostat (Comext) provided the data for EU trade flows for coking coal and coke. The end-uses of refined products of coking coal were provided by the Institute of Chemical Processing of Coal (IChPW).

<sup>82</sup> Commission's Communication 'on the 2017 list of Critical Raw Materials for the EU' (COM(2017) 490 final)

### 8.7.1 Data sources used in the factsheet

Alves Dias, P. et al. (2018) EU coal regions : opportunities and challenges ahead. JRC Science for Policy Report. Joint Research Center (JRC). European Commission (EC). doi: 10.2760/064809.

BGR (2017) BGR Energy Study 2017 - Data and Developments Concerning German and Global Energy Supplies. Federal Institute for Geosciences and Natural Resources (Bundesanstalt für Geowissenschaften und Rohstoffe – BGR). Available at: [https://www.bgr.bund.de/EN/Themen/Energie/Produkte/energy\\_study\\_2017\\_summary\\_en.html](https://www.bgr.bund.de/EN/Themen/Energie/Produkte/energy_study_2017_summary_en.html).

BGR (2019) BGR Energy Study 2018 – Data and Developments Concerning German and Global Energy Supplies. Hannover. Available at: [https://www.bgr.bund.de/DE/Themen/Energie/Downloads/energiestudie\\_2018.pdf?\\_\\_blob=publicationFile&v=10](https://www.bgr.bund.de/DE/Themen/Energie/Downloads/energiestudie_2018.pdf?__blob=publicationFile&v=10).

BGS (2010) 'Mineral Profile: Coal'. Available at: <https://www.bgs.ac.uk/mineralsUK/statistics/mineralProfiles.html>.

BIO Intelligence Service (2015) Study on Data for a Raw Material System Analysis: Roadmap and Test of the Fully Operational MSA for Raw Materials. Available at: <https://ec.europa.eu/jrc/en/scientific-tool/msa>.

BP (2018) Statistical Review of World Energy. 67th edition. Available at: <https://www.bp.com/content/dam/bp/business-sites/en/global/corporate/pdfs/energy-economics/statistical-review/bp-stats-review-2018-full-report.pdf> (Accessed: 3 July 2019).

BP (2019) Statistical Review of World Energy - all data, 1965-2018. Available at: <https://www.bp.com/en/global/corporate/energy-economics/statistical-review-of-world-energy.html> (Accessed: 5 July 2019).

Commodity Insights (2018) Market Demand Study : Australian Metallurgical Coal Report. Available at: <https://minerals.org.au/news/market-demand-study-australian-metallurgical-coal>.

CRM Alliance (2018) Coking Coal. Available at: <http://criticalrawmaterials.org/coking-coal/> (Accessed: 3 July 2019).

CRM experts (2019) 'Feedback and comments submitted after the CRM validation workshop'.

CRU (2018) Metallurgical coal still extremely profitable but rising costs should not be ignored, CRU Knowledge and Insights. Available at: <https://www.crugroup.com/knowledge-and-insights/insights/2018/metallurgical-coal-still-extremely-profitable-but-rising-costs-should-not-be-ignored/> (Accessed: 9 July 2019).

Deloitte (2018) Overview of the Steel and Iron Ore Market. Moscow. Available at: <https://www2.deloitte.com/ru/en/pages/research-center/articles/overview-of-steel-and-iron-market.html>.

Diez, M. A., Alvarez, R. and Barriocanal, C. (2002) 'Coal for metallurgical coke production : predictions of coke quality and future requirements for cokemaking', International Journal of Coal Geology, 50, pp. 389–412. Available at: <https://www.sciencedirect.com/science/article/pii/S0166516202001234>.

ESTAT Comext (2019) Easy Comext database. Available at: <http://epp.eurostat.ec.europa.eu/newxtweb/>.

Euracoal (2017) Coal Industry Across Europe. 6th edition. Available at: <https://euracoal.eu/library/publications/>.

Euracoal (2018) 'Market Report 1/2018', (April 2018). Available at: <https://euracoal.eu/library/coal-market-reports/>.

Euracoal (2019) International coal trade. Available at: <https://euracoal.eu/coal/international-coal-trade/> (Accessed: 9 July 2019).

Eurofer (2019a) 'Comments from Eurofer provided to DG GROW following the CRM Ad Hoc Working Group meeting and SCRREEN Experts Workshop.'

Eurofer (2019b) 'CRM experts comments. Eurofer's 2013 coking coal factsheet'.

Euromines (2019) 'The raw materials contribution to the implementation of the EU Sustainable Finance Action Plan'. Available at: [http://www.euromines.org/files/euromines\\_sustainable-finance\\_297x210mm\\_fin.pdf](http://www.euromines.org/files/euromines_sustainable-finance_297x210mm_fin.pdf)

European Commission (2011) Critical raw materials. Available at: [https://ec.europa.eu/growth/sectors/raw-materials/specific-interest/critical\\_en](https://ec.europa.eu/growth/sectors/raw-materials/specific-interest/critical_en) (Accessed: 8 July 2019).

European Commission (2012) 'European Coal resources : a geographical database and map of EU coal basins including potential sources of coal bed methane based on a harmonised typology Terminology and classification for the EUCORES', p. 31. Available at: <http://ec.europa.eu/energy/coal/eucores/doc/20120805-eucores-proposal-classification.pdf>.

European Commission (2014) Report on critical raw materials for the EU - Critical raw materials profiles. Available at: <https://ec.europa.eu/docsroom/documents/11911/attachments/1/translations/en/renditions/pdf>.

European Commission (2017) Study on the review of the list of critical raw materials. Non-Critical Raw Materials Factsheets. European Commission. doi: 10.2873/876644.

European Commission (2018) In-depth analysis in support of the Commission Communication COM(2018)/773. 'A Clean Planet for all. A European strategic long-term vision for a prosperous, modern, competitive and climate neutral economy'. Available at: [https://ec.europa.eu/clima/sites/clima/files/docs/pages/com\\_2018\\_733\\_analysis\\_in\\_support\\_en\\_0.pdf](https://ec.europa.eu/clima/sites/clima/files/docs/pages/com_2018_733_analysis_in_support_en_0.pdf).

Eurostat (2019) Annual detailed enterprise statistics for industry (NACE Rev. 2, B-E). Available at: [https://ec.europa.eu/eurostat/en/web/products-datasets/-/SBS\\_NA\\_IND\\_R2](https://ec.europa.eu/eurostat/en/web/products-datasets/-/SBS_NA_IND_R2) (Accessed: 7 July 2019).

European Commission (2019) Negotiations and agreements - Trade. Available at: <http://ec.europa.eu/trade/policy/countries-and-regions/negotiations-and-agreements/> (Accessed: 7 July 2019).

IChPW (2019) 'Institute for Chemical Processing of Coal. Expert comments'.

IEA (2018) Coal Information 2018: Overview. Available at: <https://webstore.iea.org/coal-information-2018-overview> (Accessed: 10 July 2019).

JSW (2019a) Coke and By-Products, Jastrzębska Spółka Węglowa SA - For contractors -. Available at: <https://www.jsw.pl/en/for-contractors/coke-and-by-products/> (Accessed: 12 July 2019).

JSW (2019b) 'Revision of Critical Raw Materials list. JSW SA position paper'.

Mitsubishi Chemical Corporation (2019). Mitsubishi Chemical Corporation, Miracles of Fossils, Available at: [https://www.m-chemical.co.jp/en/products/departments/mcc/coke/product/1201080\\_7940.html](https://www.m-chemical.co.jp/en/products/departments/mcc/coke/product/1201080_7940.html)

OECD (2019a) Export Restrictions on Industrial Raw Materials. Available at: [https://qdd.oecd.org/subject.aspx?Subject=ExportRestrictions\\_IndustrialRawMaterials](https://qdd.oecd.org/subject.aspx?Subject=ExportRestrictions_IndustrialRawMaterials) (Accessed: 5 July 2019).

OECD (2019b) Global Material Resources Outlook to 2060, Global Material Resources Outlook to 2060. doi: 10.1787/9789264307452-en.

Ozon, D. (2018) 'JSW - innovative , critical EU demand for coking coal'. Available at: <https://www.coalsteel.eu/summary/>.

Pardo, N., Moya, J. A. and Vatopoulos, K. (2015) JRC Scientific and Policy Reports. Prospective Scenarios on Energy Efficiency and CO2 Emissions in the EU Iron & Steel Industry. doi: 10.2790/64264.

Prairie Mining (2019) Prairie Mining Limited. Projects. Available at: <http://www.pdz.com.au/> (Accessed: 8 November 2019).

Remus, R. et al. (2013) Best Available Techniques (BAT) Reference Document for Iron and Steel Production. Joint Research Center (JRC). European Commission (EC). doi: 10.2791/97469.

SCRREEN workshop (2019) 'Validation workshop on Critical Raw Materials, 10-12 September 2019, Thon Hotel Brussels City Centre'. Brussels.

S&P Global Market Intelligence (2018) Australian metallurgical coal production to increase 17 % by 2025.

S&P Global Market Intelligence (2019a) Commodity profile. Coal. Price charts, Market Intelligence Platform. Available at: <https://www.spglobal.com/marketintelligence/en/campaigns/metals-mining> (Accessed: 3 July 2019).

S&P Global Market Intelligence (2019b) PDAC 2019 — Outlook for steelmaking raw materials and China.

Sundqvist Ökvist, L. et al. (2018) Production technologies of critical raw materials from secondary resources. SCRREEN project D.4.2. Available at: <http://screen.eu/results/>.

Tercero, L. et al. (2018) Critical Raw Material substitution profiles. SCRREEN project D5.1., SCRREEN - D5.1. Available at: <http://screen.eu/wp-content/uploads/2018/05/SCRREEN-D5.1-CRM-profiles.pdf>.

UN Comtrade (2019) International Trade Statistics Database. Available at: <https://comtrade.un.org/> (Accessed: 8 July 2019).

US EIA (2019) Coal Prices and Outlook, US Energy Information Administration, Coal explained. Available at: [https://www.eia.gov/energyexplained/index.php?page=coal\\_prices](https://www.eia.gov/energyexplained/index.php?page=coal_prices) (Accessed: 10 July 2019).

VDKI (2017) Annual Report 2017. Facts and Trends 2016/2017. Verein der Kohlenimporteure. Available at: <https://english.kohlenimporteure.de/publications/annual-report-2018.html>.

World Bank (2018) Aggregate Governance Indicators 1996-2017, Worldwide Governance Indicators. Available at: <http://info.worldbank.org/governance/WGI/#home> (Accessed: 7 July 2019).

World Coal Association (2019) How is steel produced?, What is coal. Available at: <https://www.worldcoal.org/coal> (Accessed: 3 July 2019).

World Coal Institute (2009) Coal & Steel report. Available at: <papers3://publication/uuid/3F82BBD9-61F6-4283-8B55-43FAC4DFB0F5>.

WMD (2019) World Mining Data 2019, Reichl, C.; Schatz, M; Zsak, G. Iron and Ferro Alloy Metals, non Ferrous Metals, Precious Metals, Industrial Minerals, Mineral Fuels. Austrian Federal Ministry of Sustainability and Tourism. [online] Available at: [www.en.bmwfw.gv.at/Energy/WorldMiningData/Seiten/default.aspx](http://www.en.bmwfw.gv.at/Energy/WorldMiningData/Seiten/default.aspx)

Worldsteel (2018) World Steel Association. Steel Statistical Yearbook 2018, WorldSteel Association. Available at: <https://www.worldsteel.org/steel-by-topic/statistics/steel-statistical-yearbook.html>.

WorldSteel (2019a) 'Factsheet. Steel and Raw materials'. World Steel Association. Available at: <https://www.worldsteel.org/steel-by-topic/raw-materials.html>.

WorldSteel (2019b) Raw Materials, World Steel Association. Available at: <https://www.worldsteel.org/steel-by-topic/raw-materials.html> (Accessed: 10 July 2019).

### **8.7.2 Data sources used in the criticality assessment**

BIO Intelligence Service (2015) Study on Data for a Raw Material System Analysis: Roadmap and Test of the Fully Operational MSA for Raw Materials. Available at: <https://ec.europa.eu/jrc/en/scientific-tool/msa>.

Eurofer (2019) 'Comments from Eurofer provided to DG GROW following the CRM Ad Hoc Working Group meeting and SCRREEN Experts Workshop.'

European Commission (2019) Negotiations and agreements - Trade. Available at: <http://ec.europa.eu/trade/policy/countries-and-regions/negotiations-and-agreements/> (Accessed: 7 July 2019).

Eurostat (2019) *Easy Comext database*. Available at: <http://epp.eurostat.ec.europa.eu/newxtweb/>.

IChPW (2019) 'Institute for Chemical Processing of Coal. Expert comments'.

OECD (2019) Export Restrictions on Industrial Raw Materials. Available at: [https://qdd.oecd.org/subject.aspx?Subject=ExportRestrictions\\_IndustrialRawMaterials](https://qdd.oecd.org/subject.aspx?Subject=ExportRestrictions_IndustrialRawMaterials) (Accessed: 5 July 2019).

Pardo, N., Moya, J. A. and Vatopoulos, K. (2015) JRC Scientific and Policy Reports. Prospective Scenarios on Energy Efficiency and CO2 Emissions in the EU Iron & Steel Industry. doi: 10.2790/64264.

SCRREEN workshop (2019) 'Validation workshop on Critical Raw Materials, 10-12 September 2019, Thon Hotel Brussels City Centre'. Brussels.

Tercero, L. et al. (2018) Critical Raw Material substitution profiles. SCRREEN project D5.1., SCRREEN - D5.1. Available at: <http://screen.eu/wp-content/uploads/2018/05/SCRREEN-D5.1-CRM-profiles.pdf>.



VDKI (2017) *Annual Report 2017. Facts and Trends 2016/2017*. Verein der Kohlenimporteure. Available at: <https://english.kohlenimporteure.de/publications/annual-report-2018.html>.

WMD (2019) *World Mining Data 2019*, Reichl, C.; Schatz, M; Zsak, G. Iron and Ferro Alloy Metals, non Ferrous Metals, Precious Metals, Industrial Minerals, Mineral Fuels. Austrian Federal Ministry of Sustainability and Tourism. [online] Available at: [www.en.bmwf.gv.at/Energy/WorldMiningData/Seiten/default.aspx](http://www.en.bmwf.gv.at/Energy/WorldMiningData/Seiten/default.aspx)

World Coal Association (2019) *How is steel produced?, What is coal*. Available at: <https://www.worldcoal.org/coal> (Accessed: 3 July 2019).

WorldSteel (2019) 'Factsheet. Steel and Raw materials'. World Steel Association. Available at: <https://www.worldsteel.org/steel-by-topic/raw-materials.html>.

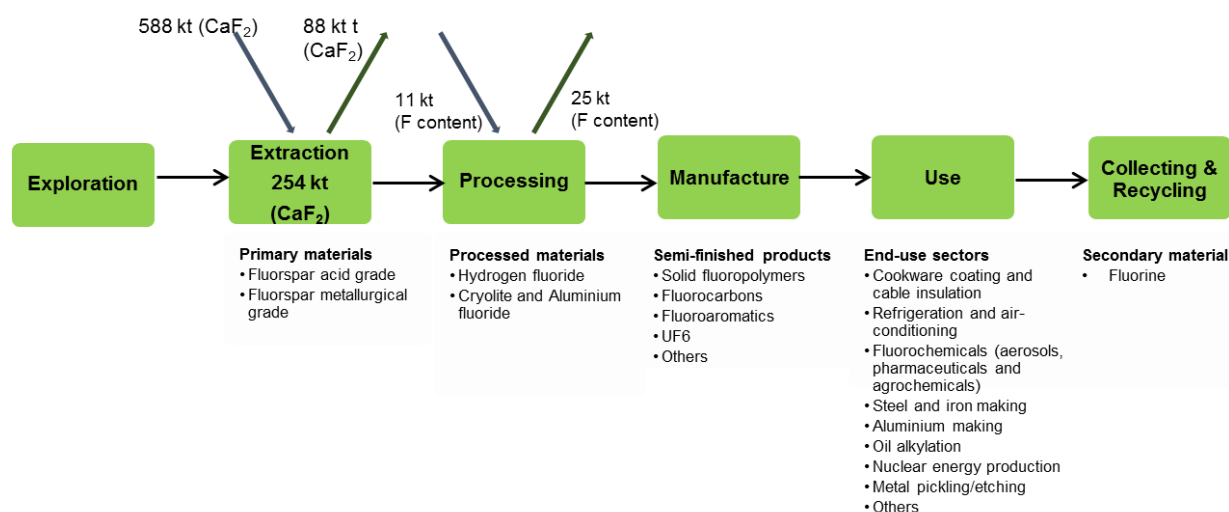
## **8.8 Acknowledgements**

---

This factsheet was prepared by the JRC. The authors would like to thank the Ad Hoc Working Group on Critical Raw Materials, as well as experts participating in SCRREEN workshops for their contribution and feedback, and in particular Mr Aurelio Braconi (Eurofer), Mr Marek Ściażko (IChPW), Ms Antje Wittenberg (BGR), Mr Johannes Drielsma (Euromines), and Mr Gonzalo Mayoral Fernández (Kerogen Energy).

# 9 FLUORSPAR

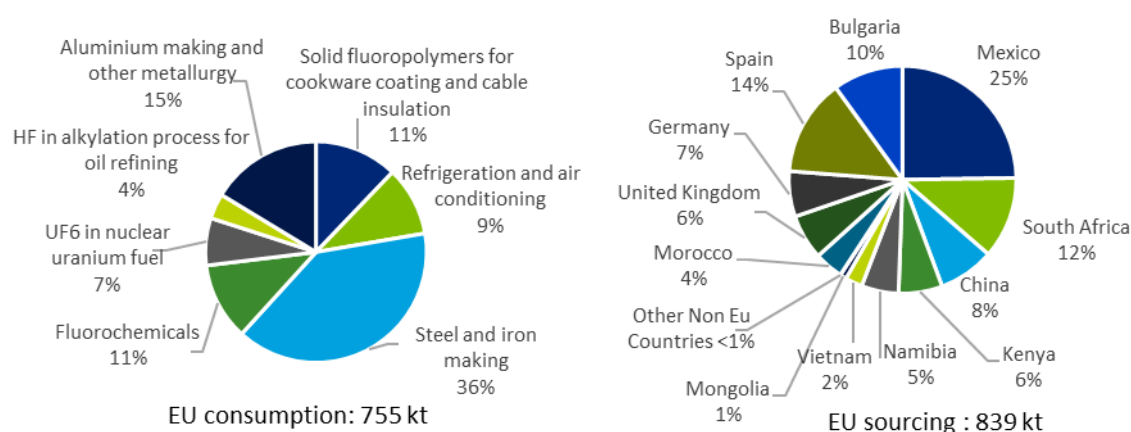
## 9.1 Overview



**Figure 121: Simplified value chain for fluorspar<sup>83</sup> in the EU (average 2012 to 2016)**

Fluorspar is the commercial name for the mineral fluorite (calcium fluoride,  $\text{CaF}_2$ ). Fluorite is a colorful, widely occurring mineral that occurs globally with significant deposits in over 9,000 areas. Fluorspar was on the list of CRMs in 2011, 2014, 2017.

For the purpose of this assessment fluorspar at both extraction and processing stage are analysed. At mine stage, fluorspar is assessed in the form of fluorspar acid grade "AG" (assuming 97%  $\text{CaF}_2$  contained, CN8 code 25292200) and metallurgical grade "MG" (assuming 84%  $\text{CaF}_2$  contained, CN8 code 25292100). At processing stage, the following products are considered: hydrogen fluoride (HF, 95% F contained, HS 281111), cryolite ( $\text{Na}_3\text{AlF}_6$ , 54% F contained, HS 282630) and aluminum fluoride ( $\text{AlF}_3$ , 68% F contained, HS 282612).



**Figure 122: End uses (CRM Experts, 2019b) and EU sourcing of Fluorspar at mine stage (Acid-Grade and Metallurgical-Grade) (Eurostat Comext 2019a)**

<sup>83</sup>JRC elaboration on multiple sources (see next sections). The quantity of processing stage in the EU represents the figure from criticality assessment 2017.

In the assessment, the figures of fluorspar reported in extraction stage is expressed in  $\text{CaF}_2$  content while for processing stage the quantities are expressed in fluorine (F) content.

The fluorspar market is segmented into four applications: aluminum production, steel production, hydrofluoric acid, and others. Acid grade fluorite and metallurgical fluorite together account for over 95% of the global fluorspar market share (Marketwatch Press Release, 2019).<sup>84</sup> The majority of fluorspar is traded on annual contracts and only small amounts are sold on the open market (BGS, 2011). The average annual acidspars prices have decreased drastically in the last years, from USD 399 per tonne in 2014 to USD 265 per tonne in 2018 (DERA, 2019).

The average annual EU apparent consumption of fluorspar over the period 2012-2016 was estimated at 755 kt with 74% of consumption in the form of acid grade and 26% in metallurgical grade. The EU sourced fluorspar through domestic production (in Spain, Bulgaria and Germany) and imports (mainly from Mexico, South Africa, China, Kenya and Namibia). The EU was a net importer of fluorspar at mine stage with an EU import reliance of 66%. Between 2012 and 2016, the EU was net exporter of fluorspar containing products such as hydrogen fluoride, cryolite and aluminum fluoride.

Fluorspar is mainly used in steel and iron making, refrigeration and air conditioning, aluminium making, solid fluoropolymers for cookware and cable insulation, fluorochemicals, nuclear uranium fuel and in processes for oil refining.

Fluorspar resources are widespread globally and major deposits can be found on every continent. Identified world fluorspar resources were approximately 500 million tonnes of contained fluorspar (USGS, 2019). Resource data for some countries in Europe are available at Minerals4EU (2019) but cannot be summed as they are partial and they do not use the same reporting code. World known reserves of fluorspar are estimated at around 310 million tonnes (as 100% equivalent  $\text{CaF}_2$ ) (USGS, 2019). Mexico has the world's largest fluorspar reserves, followed by China and South Africa (USGS, 2019).

The world average annual production of fluorspar ( $\text{CaF}_2$ ) at mine stage in the period 2012-2016 was reported at 6,358 kt per year. The ore production is strongly concentrated with 65% of production in China and 15% in Mexico (WMD, 2019). The European production of fluorspar was 254 kt of acid grade fluorspar (no production of metallurgical grade fluorspar in the EU) (WMD, 2019).

There was not any supply of fluorspar from secondary sources. Given the type of applications, fluorspar is not recyclable (European Commission, 2014). Fluorspar contained in waste mainly ends up in landfill (Bio Intelligence Service, 2015).

On the 1<sup>st</sup> of January 2019, The UN Environment Programme (UNEP) announced the entry of the Kigali Amendment to the Montreal Protocol on Substances that Deplete the Ozone Layer into force, following ratification by 65 countries. It has resulted in new legislation in many countries, which reduces the production and consumption of hydrofluorocarbons, shortening the demand for fluorspar (USGS, 2018).

Until 2010, China had an export quota on fluorspar (550 kt/y). China also imposed export taxes (15%) on acid grade fluorspar, which ended in 2013 (OECD, 2019). On processed products, China applied 5% of export tax for fluorides of aluminium (HS 282612) that ended in 2014. Kenya imposed an export tax of 1% to both acid and metallurgical grade fluorspar (commodities under trade code HS 252922) for its exports to Eritrea, Ethiopia,

---

<sup>84</sup> The remainder of the ceramic grade fluorite is not considered in this assessment due to minor economic relevance

and Swaziland. Mongolia also imposed a fiscal tax on exports on both acid and metallurgical grade fluorspar (OECD, 2019).

## 9.2 Market analysis, trade and prices

---

### 9.2.1 Global market analysis and outlook

Globally, fluorspar is used mainly in three industry fields. First, acid-grade fluorspar is used in the chemical sector for the manufacture of hydrofluoric acid (HF), a precursor to the production of most other fluorine-containing chemicals, accounting for approximately 40% of the annual global fluorspar consumption. Secondly, fluorspar is used in metallurgical-grade as steelmaking flux, accounting for 30% of the global consumption. Thirdly, acid-grade fluorspar is used in the manufacture of aluminum fluoride (AlF<sub>3</sub>) and cryolite (Na<sub>3</sub>AlF<sub>6</sub>) for aluminum smelting, accounting for approximately 18% of the global consumption. In contrast to the manufacture of hydrofluoric acid and products derived from it, fluorspar is in the second and third application not incorporated in the final products. Other applications of fluorspar include use in the manufacture of cement, ceramics, enamel, glass, and welding rod coatings (Sundqvist Oeqvist, Pr. Lena et al., 2018).

China shows the largest mine production of fluorspar worldwide, with average annual production more than half of the global supply for the period 2012-2016. New fluorspar production capacity in Canada came online in 2018 that has reportedly sent fluorspar to the United States for further processing (USGS, 2019). In 2019, new capacity became available also in South Africa. These new mine production sites will contribute to significant increases of both South African and Canadian production. In Canada, the production capacity of fluorspar is expected to increase up to 200 kt per year acid-grade concentrate, while South Africa is expected to produce 180 kt per year of acid grade fluorspar plus 30 kt per year metallurgical grade fluorspar including plans to produce HF and aluminium fluoride (Roskill, 2019).

In the coming years the future demand for fluorspar will highly depend on the development and use of fluorocarbon substitutes; considering that the use of fluorocarbon in refrigeration will be phased down, especially for HFCs with high GWP (F Gas Regulation EU 517/ 2014; The Kigali Amendment to the Montreal Protocol). Hydrofluoroolefins (HFO-1234ze, HFO-1234yf, HFO-1233zd) and mixtures based on HFOs are considered to be the most likely replacement for fluorocarbons for due to their low GWP (The Chemours Company, 2016). Due to the high amount of fluorine used in the manufacturing process, the fluorspar industry will be able to take advantage of such new developments (USGS, 2016).

No reliable forecast for the EU demand and supply for the next 5, 10 and 20 years have been obtained from market and industry experts (Table 50).

An expert envisioned a slight growth in global hydrofluorocarbons production and consumption in the short term; strong growth in the production and consumption of hydrofluoroolefins (HFOs), especially for mobile air conditioning and plastic foam blowing; moderate growth for fluorochemicals used for fluoroplastic and fluoroelastomer production; and moderate continuing growth for Hydrofluoric acid (HF) for downstream fluorochemicals production and direct uses (Imformed, 2019).

**Table 50: Qualitative forecast of supply and demand of fluorspar**

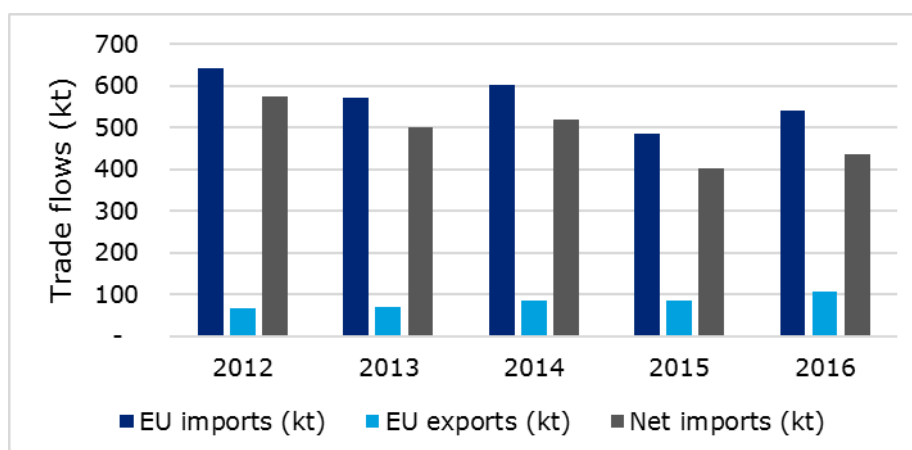
Materials	Criticality of the material in 2020		Demand forecast			Supply forecast		
	Yes	No	5 years	10 years	20 years	5 years	10 years	20 years
Fluorspar	x		?	?	?	?	?	?

### 9.2.2 EU trade

At mine stage, fluorspar is assessed in the form of fluorspar acid grade "AG" (min. 97% CaF<sub>2</sub> contained, CN8 code 25292200) and metallurgical grade "MG" (84% CaF<sub>2</sub> contained, CN8 code 25292100). Ceramic grade fluorite is not considered here.

Quantities are given as CaF<sub>2</sub> content. At processing stage, the following products are considered: hydrogen fluoride (HF, 95% F contained, HS 281111), cryolite (Na<sub>3</sub>AlF<sub>6</sub>, 54% F contained, HS 282630) and aluminum fluoride (AlF<sub>3</sub>, 68% F contained, HS 282612). In the assessment, the figures of fluorspar reported in extraction stage is expressed in CaF<sub>2</sub> content while for processing stage the quantities are expressed in fluorine (F) content

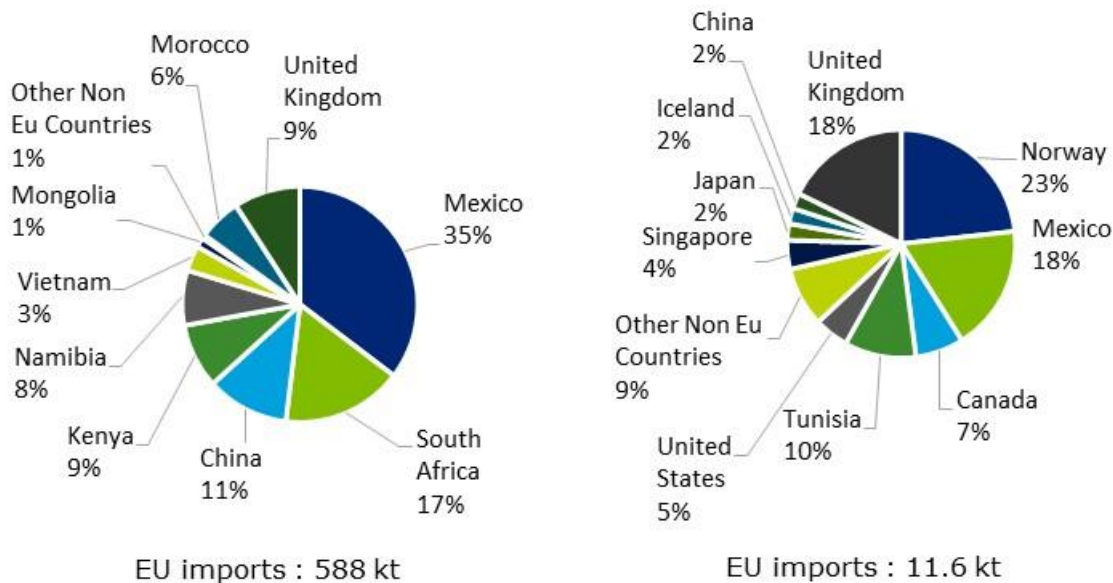
The EU was a net importer of fluorspar at mine stage in 2012-2016 (AG and MG). With an average of about 588 kt per year (CaF<sub>2</sub> content), the EU import is six times higher than EU export over the year 2012-2016 (Eurostat Comext, 2019). The EU export is of fluorspar was estimated at 88 kt per year.



**Figure 123: EU trade flows for acid grade and metallurgical grade fluorspar (Eurostat, 2019a)**

The main countries from which the EU imported in the period 2012-2016 were Mexico (35%), South Africa (17%), China (11%), Kenya and Namibia (9% and 8%) (see Figure 124). Free Trade Agreements are in place between the EU and Mexico, South Africa and Namibia.

There were several export restrictions in place between the EU and its suppliers in the period 2012-2016. China imposed an export quota and export taxes on fluorspar, meanwhile the export quota (550 kt) ended in 2010 and the export taxes (15%) ended in 2013 (OECD, 2019). Mongolia also imposed a fiscal tax on exports on both acid and metallurgical grade fluorspar.



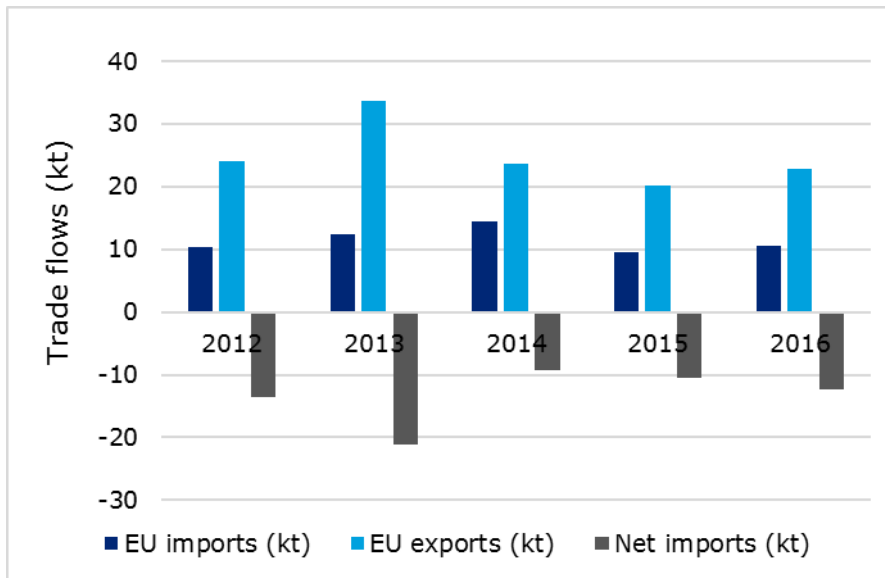
**Figure 124: EU imports of acid grade and metallurgical grade Fluorspar (left) and processed Fluorspar (right) (Data source: Eurostat, 2019b)**

According to the data reported in Eurostat Comext (2019), only 10% of the EU processed fluorspar supply was imported (about 12 kt per year, in average of the period 2012-2016). These imports were mainly coming from Norway (23%), United Kingdom (18%), and Mexico (18%). Over the year 2012-2016, the average annual quantities of processed fluorspar imported to the EU were as follows:

- Hydrogen fluoride "hydrofluoric acid" (HS 281111) at 4.6 kt per year of fluorine content (accounting 36% of import),
- Sodium Hexafluoroaluminate - synthetic cryolite (HS 282630) at 1.39 kt per year (12% of import),
- Fluoride of aluminium (HS 282612), 5.9 kt per year of fluorine content (52% of share).

The Agreement on the European Economic Area (EEA) is in place between the EU and Norway. China applied a 5% export tax for fluorides of aluminium (HS 282612), but it ended in 2014.

The EU is a net exporter of processed fluorspar with an average export quantity of 24.8 kt of fluorine content per year in the period 2012-2016.

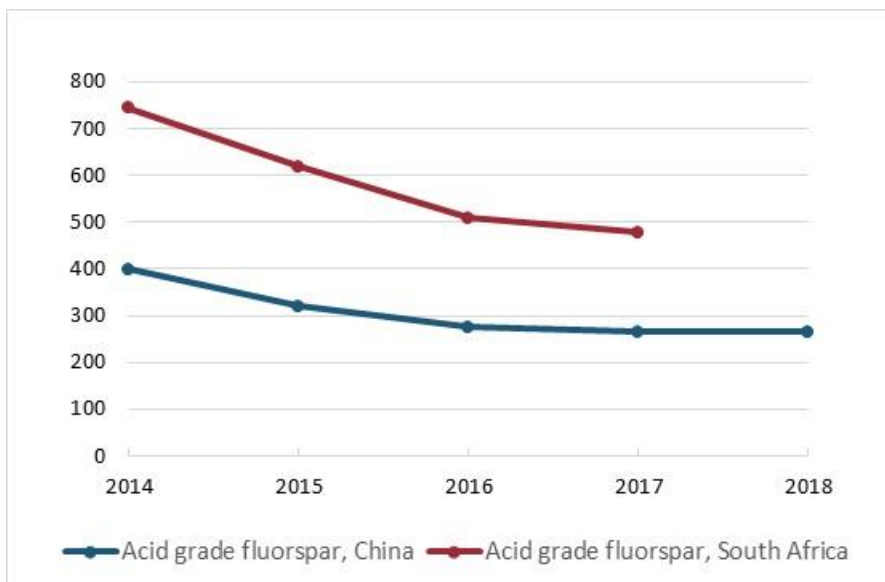


**Figure 125: EU trade flows for processed fluorspar (hydrogen fluoride, synthetic cryolite, and fluoride of aluminium, in F content) (Data source: Eurostat, 2019a)**

### 9.2.3 Prices and price volatility

The major part of fluorspar is traded on annual contracts and only small amounts are sold on the open market (BGS, 2011).

Figure 126 shows the price trends of acid grade fluorspar from 2014 to 2018 in South Africa and China. In general, the acid-grade fluorspar price has been declining steadily in both countries. The decline is believed to have been due to oversupply in acid grade fluorspar and increased regulation of fluorinated gases, such as refrigerants, aerosols, and foam-blowing agents, in Europe and North America (USGS, 2016).



**Figure 126: Prices of fluorspar (USD per tonne) from 2014 to 2018 (DERA, 2019)**

## 9.3 EU demand

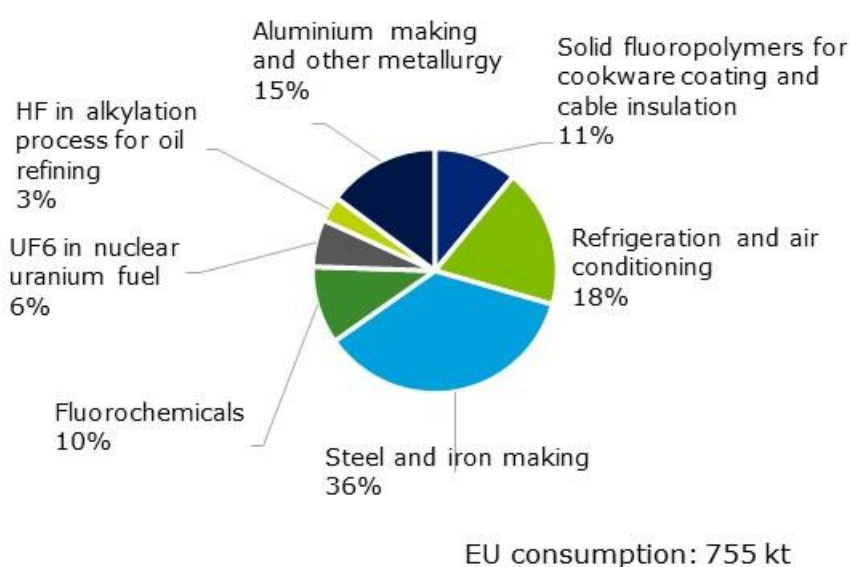
The major part of the global demand of fluorspar comes from the production of hydrofluoric acid (HF) and aluminum fluoride (AlF<sub>3</sub>). The fluorspar market is segmented into four applications: aluminum production, steel production, hydrofluoric acid, and others. Acid grade and metallurgical grade fluorspar together account for a market share over 95% of the global fluorspar market at market stage (Marketwatch Press Release, 2019).

### 9.3.1 EU demand and consumption

Over the years 2012-2016, the annual average EU apparent consumption of fluorspar at mine stage was 755 kt per year (CaF<sub>2</sub> content), equivalent to 367 kt of fluorine content, mainly sourced from imports. The EU imports of processed fluorspar, summing the fluorine content in hydrofluoric acid, aluminum fluoride AlF<sub>3</sub>, and cryolite, were estimated at 11.6 kt (F content).

### 9.3.2 Uses and end-uses of Fluorspar in the EU

Figure 127 presents the main uses of fluorspar in the EU in the period 2012-2016.



**Figure 127: EU end uses of fluorspar (SCREEN, 2019). Average figures for 2012-2016 (Data source: Eurostat, 2019a).**

The EU end-uses of fluorspar products are summarised as follows (Bio Intelligence Service, 2015):

- Solid fluoropolymers for cookware coating, cable insulation and membranes: Solid fluoropolymers is used for cookware coating and cable insulation in household electrical appliances, lighting industry, telecommunications, aeronautics, nuclear, military, fuel-cells
- Refrigeration and air conditioning: fluorochemicals are used for the production of refrigerants for refrigeration (refrigerator) and air conditioning in automobiles or other vehicles (military) and heat-pumps
- Steel and iron making: Metspar in Iron & Steel making (internal process use)
- Fluorochemicals: Used as Inorganic fluorine compounds, as well as in the form of Fluoroaromatics in pharmaceuticals and agrochemicals industry and Aerosols (dissipative)



- Uranium hexafluoride (UF<sub>6</sub>) in nuclear uranium fuel
- Hydrogen Fluoride (HF) in alkylation process for oil refining
- Aluminium making and other metallurgy: fluorspar is used for aluminum processing (internal process use of AlF<sub>3</sub> and cryolite), as well as Aqueous HF for pickling/etching applications (internal process use)

The relevant industry sectors for fluorspar application are described using the NACE sector codes in Table 51.

**Table 51: Fluorspar applications, 2-digit and associated 4-digit NACE sectors, and value added per sector (Eurostat, 2019b)**

<b>Applications</b>	<b>2-digit NACE sector</b>	<b>4-digit NACE sectors</b>	<b>Value added of NACE 2 sector (M€)</b>
Solid fluoropolymers for cookware coating and cable insulation	C27 - Manufacture of electrical equipment	C2750- Manufacture of electric domestic appliances; C2740- Manufacture of electric lighting equipment	80,745
Refrigeration and air conditioning	C27 - Manufacture of electrical equipment	C2750- Manufacture of electric domestic appliances; C2819- Manufacture of non-domestic cooling and ventilation equipment;	80,745
Refrigeration and air conditioning	C29 - Manufacture of motor vehicles, trailers and semi-trailers	C2920- Manufacture of electrical and electronic equipment for motor vehicles	160,603
Steel and iron making	C24 - Manufacture of basic metals	C2410- Manufacture of basic iron and steel and of ferro-alloys	55,426
Fluorochemicals	C20 - Manufacture of chemicals and chemical products	C2011- Manufacture of other organic basic chemicals; C2021- Manufacture of pesticides and other agrochemical products; C2029- Manufacture of other chemical products n.e.c.	105,514
UF <sub>6</sub> in nuclear uranium fuel	C24 - Manufacture of basic metals	C2420- Processing of nuclear fuel	55,426
HF in alkylation process for oil refining	C19 - Manufacture of coke and refined petroleum products	C1920 - Manufacture of refined petroleum products	17,289
Aluminium making and other metallurgy	C24 - Manufacture of basic metals	C2420- Aluminium production; C2029- Manufacture of other chemical products n.e.c.	55,426

### 9.3.3 Substitution

In the following, three particular cases for substitution of fluorspar are described.

In spite of lower performance, alternative materials for solid fluoropolymers include, (The Chemours Company, 2016):

- Plastics
- Stainless steel
- Ceramics
- Aluminum

There is a major push to substitute fluorine used in many industries (especially in the air condition and refrigerator sector) for a more environmentally friendly option (BGS, 2011). These alternative materials include hydrocarbons such as propane. Due to their low GWP, Hydrofluoroolefins (HFO-1234ze, HFO-1234yf, HFO-1233zd), and mixtures based on HFOs are considered to be the most likely replacement for fluorocarbons (The Chemours Company, 2016).

In the iron and steel making sector substitutes exist, but with a loss of performance:

- Calcium aluminate
- Aluminum smelting dross

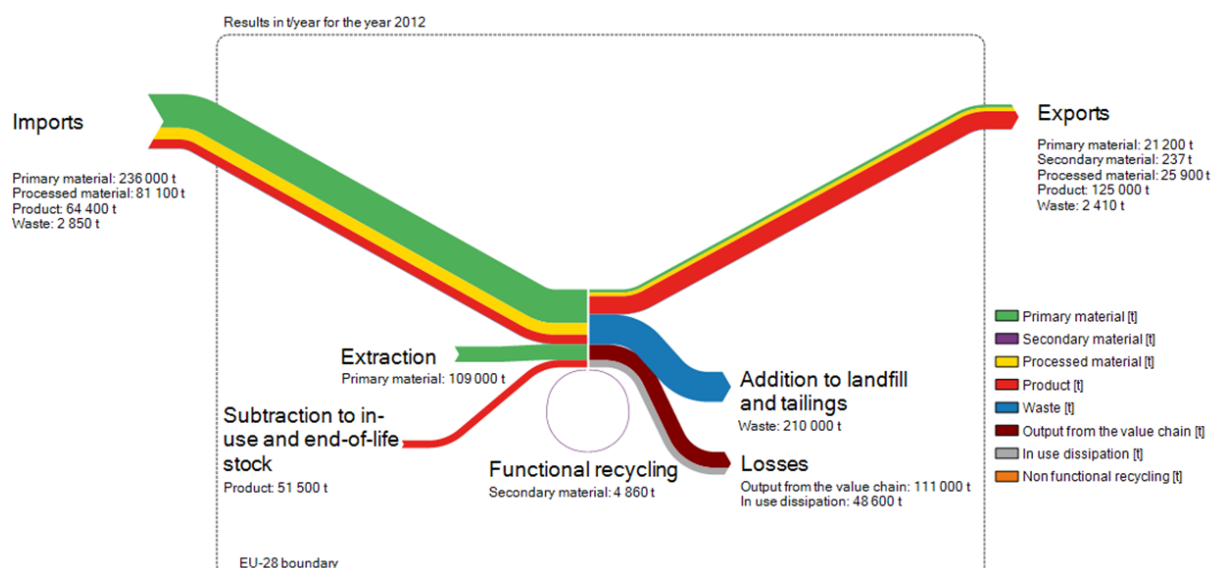
## 9.4 Supply

---

### 9.4.1 EU supply chain

The flows of fluorspar through the EU economy are demonstrated in Figure 128. The EU supply chain of fluorspar includes exploration, extraction, processing, manufacturing.

- Exploration: Occurrences in the EU have been detected in several countries in the EU
- Extraction stage: The EU remained very dependent on imports of fluorspar at mine stage, with an import reliance of 66% (average 2012-2016). The EU production of primary fluorspar over the period 2012-2016 was estimated at 254 kt per year (CaF<sub>2</sub> content) acid grade fluorspar (World Mining Data, 2019). There is no production of metallurgical grade fluorspar in the EU. Between 2012 and 2016, the EU production of fluorspar took place mainly in Spain, Germany and Bulgaria (WMD, 2019). There was some production in France and in Italy, but both activities ceased in 2006. Fluorspar mine in Bulgaria was closed in early 2016, taking approximately 30 kt per year of EU production capacity out of the market. This has an impact on the EU import reliance (CRM Alliance, 2016). At Processing stage, the EU imports and exports several important fluorspar-based products. Between 2012-2016, average EU fluorspar production was estimated at around 84 kt/y (F content, derived from global trade data). Average over 2012-2016 EU import was 12 kt per year while the export is 25 kt per year, suggesting that the EU was a net exporter of processed fluorspar during this period.



**Figure 128: Simplified Material System Analysis diagram of fluor spar, reference year 2012, EU27 and the UK(BioIntelligence, 2015)**

## 9.4.2 Supply from primary materials

### 9.4.2.1 Geology, resources and reserves of fluor spar

**Geological occurrence:** Most fluor spar occurs as vein fillings in rocks that have been subjected to hydrothermal activity (BGS, 2011). These veins often contain metallic ores which can include sulfides of tin, silver, lead, zinc, copper and other metals. Fluorite is also found in the fractures and vugs of some limestones and dolomites (BGS, 2011). Fluorite is a common mineral in hydrothermal and carbonate rocks worldwide.

**Global resources and reserves<sup>85</sup>:** Fluor spar resources are widespread globally and major deposits can be found on every continent. Identified world fluor spar resources were approximately 500 million tonnes of contained fluor spar (USGS, 2016).

World known reserves of fluor spar are estimated at around 310 million tonnes of  $\text{CaF}_2$  (USGS, 2019). Mexico has the world's largest fluor spar reserves, followed by China and South Africa.

<sup>85</sup> There is no single source of comprehensive evaluations for resources and reserves that apply the same criteria to deposits of fluor spar in different geographic areas of the EU or globally. The USGS collects information about the quantity and quality of mineral resources but does not directly measure reserves, and companies or governments do not directly report reserves to the USGS. Individual companies may publish regular mineral resource and reserve reports, but reporting is done using a variety of systems of reporting depending on the location of their operation, their corporate identity and stock market requirements. Translations between national reporting codes are possible by application of the CRIRSCO template.<sup>85</sup>, which is also consistent with the United Nations Framework Classification (UNFC) system. However, reserve and resource data are changing continuously as exploration and mining proceed and are thus influenced by market conditions and should be followed continuously.

**Table 52: Global reserves of fluorspar (USGS, 2019)**

Country	Fluorspar Reserves (million tonnes CaF <sub>2</sub> )
Argentina	NA
Brazil	1.5
China	42
Germany	NA
Iran	3.4
Kenya	2
Mexico	68
Mongolia	22
Morocco	0.46
South Africa	41
Spain	6
Thailand	3.6
United Kingdom	4
United States	4
Vietnam	5
Other countries	110

**EU resources and reserves<sup>86</sup>:**

Resource data for some countries in Europe are available at Minerals4EU (2019) )<sup>87</sup> but cannot be summed as they are partial and they do not use the same reporting code (Table 53).

**Table 53: Resource data for the EU compiled in the European Minerals Yearbook (Minerals4EU, 2019)**

Country	Reporting code	Quantity	Unit	Grade	Code Resource Type
Spain	Adapted version of the USGS Circular 831 of 1980	4,794	kt	-	Measured
France	-	9.6	Mt (CaF <sub>2</sub> content)	-	Historic Resource Estimates
UK	-	25	Mt (CaF <sub>2</sub> content)	-	Historic Resource Estimates
Sweden	JORC	25	Mt	10.28%	Indicated
Norway	JORC	4	Mt	24.6%	Inferred
Poland	Nat. rep. code	0.54	Mt	-	C2+D
Ukraine	Russian Classification	18,500	kt	-	P1

<sup>86</sup> For Europe, there is no complete and harmonised dataset that presents total EU resource and reserve estimates for fluorspar. The Minerals4EU project is the only EU-level repository of some mineral resource and reserve data for fluorspar, but this information does not provide a complete picture for Europe. It includes estimates based on a variety of reporting codes used by different countries, and different types of non-comparable datasets (e.g. historic estimates, inferred reserves figures only, etc.). In addition, translations of Minerals4EU data by application of the CRIRSCO template is not always possible, meaning that not all resource and reserve data for fluorspar the national/regional level is consistent with the United Nations Framework Classification (UNFC) system (Minerals4EU 2019). Many documented resources in Europe are based on historic estimates and are of little current economic interest. Data for these may not always be presentable in accordance with the UNFC system. However a very solid estimation can be done by experts.

<sup>87</sup> There has not been any updates on the information in Minerals4EU website since the publication of criticality assessment 2017.

Country	Reporting code	Quantity	Unit	Grade	Code Resource Type
Hungary	Russian Classification	?	Million m <sup>3</sup>	2.9t/m <sup>3</sup>	-
Serbia	-	0.8	Mt	27.01%	Historic Resource Estimates
Czech Republic	Nat. rep. code	2,033	kt	-	Potentially economic

The USGS reported EU reserves of fluorspar in Germany and Spain (Table 52). Spain has 262 occurrences of fluorspar in Asturias, Andalusia, Catalonia, Madrid, Aragón, Vizcaya, Segovia, Guadalajara, and Galicia, hosting in total 5 million tonnes of reserves (Imformed, 2019).

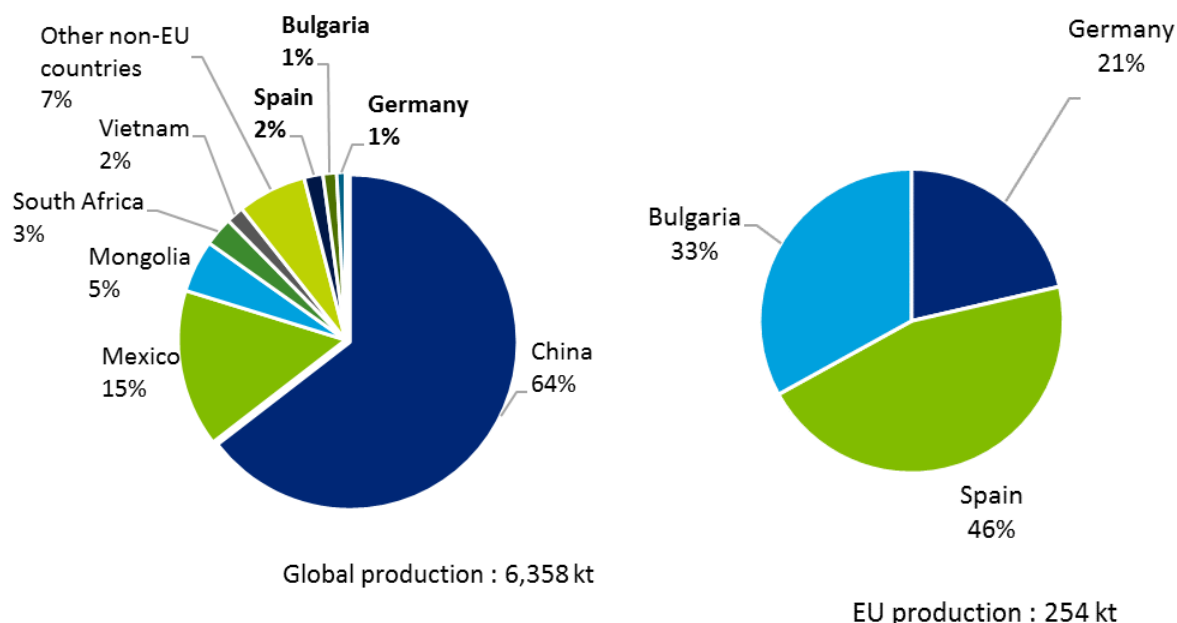
SCRREEN<sup>88</sup> listed occurrences of fluorspar in the following EU countries:

- France : Numerous occurrences were reported, with an estimate resources at about 7.3 Mt.
- Germany : Several deposits and occurrences are known, with fluorite resouces estimated at 0.92 Mt
- Italy: Approximately 35 Mt of fluorite resources were reported. Italy had fluorspar production until 2006. There is mainly only mineralogical interests for fluorspar in Italy.
- Poland: resources of fluorspar were estimated at 0.54 Mt
- Spain: resources estimated at 3.8 Mt. Spain has several tens of known fluorite deposits in several areas, the most important one Asturias in northern Spain.
- Sweden: the total estimated resource includes 25.0 Mt of Indicated resources and 2.7 Mt of Inferred resources. There are other three small historic closed mines with no resource estimates available.
- Occurrences were also reported for Austria, Czechia, Hungary, and Ireland, with no quantitative resource information. However, the resources in these countries are known to be uneconomic.

#### 9.4.2.2 World and EU mine production

After extraction, fluorspar ore is directly transformed into fluorspar acid grade (AG, 97% of CaF<sub>2</sub> contained) and metallurgical grade (MG, 84% of CaF<sub>2</sub> contained). The world annual production of fluorspar ores in average between 2012 and 2016 is around 6,400 ktonnes of CaF<sub>2</sub> content, extracted mainly in China and Mexico (see Figure 129).

<sup>88</sup> Lauri, L. et al. (2018) Identification and quantification of primary CRM resources in Europe. SCRREEN project D3.1. Available at: <http://screen.eu/results/>.



**Figure 129: Global and EU mine production of Fluorspar in tonnes and percentage. Average for the years 2012-2016. (WMD, 2019)**

### 9.4.3 Supply from secondary materials/recycling

Fluorspar is recycled only to a minor extent since its uses are dissipative, or recycling is not practicable (Sundqvist Oeqvist, Pr. Lena et al. ,2018).

#### 9.4.3.1 Post-consumer recycling (old scrap)

Fluorspar is generally not recovered from manufactured products such as flint glass, enamels, and fibreglass insulation, since it is highly dispersed in those applications. Limited recycling of fluorspar from end of life products is theoretically feasible. However, there is no information of any recycling operations ongoing in the EU and worldwide (Sundqvist Oeqvist, Pr. Lena et al. ,2018).

Fluorspar is practically not recyclable, therefore fluorspar contained in the waste mainly ends up in landfills (European Commission, 2014). According to the MSA study of fluorspar, the end of life recycling input rate is 1%. (Bio Intelligence Service, 2015).

Table 54 show the quantity of flows relevant to the end-of-life recycling input rate of fluorspar in the EU. The data refers to 2012.

**Table 54: Material flows relevant to the EOL-RIR of Fluorspar<sup>89</sup>**

MSA Flow	Value (t)
B.1.1 Production of primary material as main product in EU sent to processing in EU	87312
B.1.2 Production of primary material as by product in EU sent to processing in EU	0
C.1.3 Imports to EU of primary material	236303
C.1.4 Imports to EU of secondary material	0
D.1.3 Imports to EU of processed material	81142
E.1.6 Products at end of life in EU collected for treatment	130813
F.1.1 Exports from EU of manufactured products at end-of-life	193
F.1.2 Imports to EU of manufactured products at end-of-life	2847
G.1.1 Production of secondary material from post consumer functional recycling in EU sent to processing in EU	0
G.1.2 Production of secondary material from post consumer functional recycling in EU sent to manufacture in EU	4861

#### 9.4.3.2 Industrial recycling (new scrap)

Although fluorspar itself is not recyclable, a few thousand tons of synthetic fluorspar are recovered each year during the uranium enrichment (as well as stainless steel pickling and petroleum alkylation). In the case of aluminum producers, hydrofluoric acid (HF) and fluorides are recovered during the smelting operations (USGS, 2015). In the air-conditioning and refrigeration sector, close to 60-70% of the fluorochemicals are recycled (The Chemours Company, 2016).

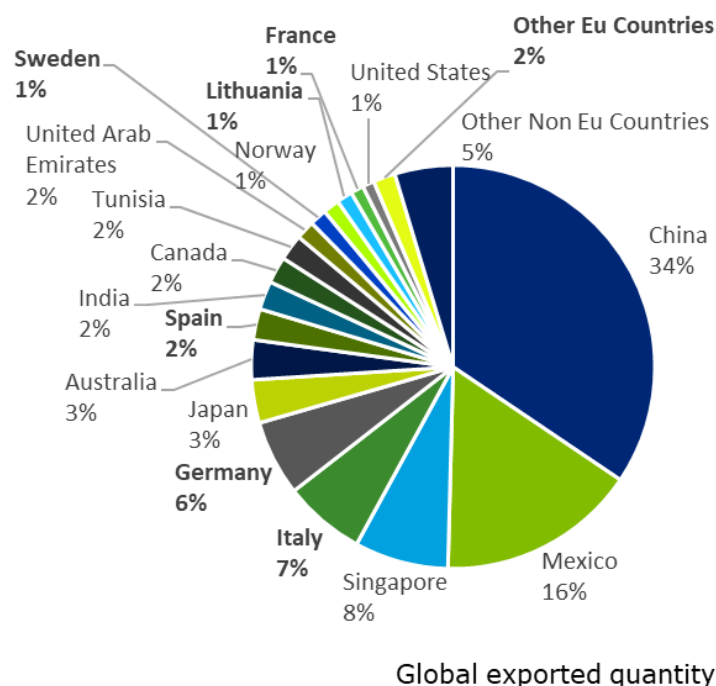
#### 9.4.4 Processing of fluorspar

The acid grade (AG) and metallurgical grade (MG) fluorspar are processed into hydrofluoric acid (HF), cryolite ( $\text{Na}_3\text{AlF}_6$ ) and aluminum fluoride ( $\text{AlF}_3$ ).

Fluorspar MG is also used in iron and steel making, but is not incorporated into the iron and steel products. The processed material HF is converted into semi-finished products such as fluorocarbons, fluoropolymers, fluoroaromatics and uranium hexafluoride ( $\text{UF}_6$ , used in nuclear energy production), or it is directly converted into finished products such as inorganic fluorine compounds. HF is also used for etching and pickling of metals and for alkylation process in oil refining, however, fluorine is not transferred in the final products for these applications. In the same way, cryolite and aluminum fluoride are used for aluminum processing, but are not incorporated in aluminum alloys. Fluorocarbons, fluoropolymers and fluoroaromatics are used in finished products in various applications such as cable insulation, fire protection, refrigerants, pharmaceuticals, etc.

There is no official data on the global supply of processed fluorspar, or on its components: of global hydrofluoric acid (HF), cryolite ( $\text{Na}_3\text{AlF}_6$ ) and aluminum fluoride ( $\text{AlF}_3$ ). Based on the export quantity of processed fluorspar reported by UNComtrade (2019), the average annual processed fluorspar in the period 2012-2016 was 839 kt per year of fluorine content. As shown in Figure 130, the production of processed fluorspar is concentrated mainly in China (34%) and Mexico (16%).

<sup>89</sup> EOL-RIR=(G.1.1+G.1.2)/(B.1.1+B.1.2+C.1.3+D.1.3+C.1.4+G.1.1+G.1.2)



**Figure 130: Global and EU production of fluorospar products, in fluorine content. Average for the period 2012-2016 (Comtrade, 2019)**

## 9.5 Other considerations

### 9.5.1 Environmental and health and safety issues

In the coming years, the demand for fluorospar will highly depend on the development and use of fluorocarbon substitutes; considering the phase-out of the use of fluorocarbon in refrigeration, especially for HFCs with high greenhouse warming potential (GWP) (F Gas Regulation EU 517/ 2014; The Kigali Amendment to the Montreal Protocol). Hydrofluoroolefins (HFOs) (HFO-1234ze, HFO-1234yf, HFO-1233zd) and mixtures based on HFOs are considered to be the most likely replacement due to their low GWP (The Chemours Company, 2016). Due to the high amount of fluorine used in the manufacturing process, the fluorospar industry will be able to take advantage of such new developments (USGS, 2016).

## 9.6 Comparison with previous EU assessments

The assessment has been conducted using the same methodology as for the 2017 list. The results of the criticality assessment 2020 and earlier assessments are shown in Table 55.

Supply risk for fluorospar has been analysed at both extraction and processing stage. No data on the global supply of processed fluorospar was available, therefore the supply risk at processing stage was calculated using EU supply risk. The lower supply risk of processed fluorospar is caused by a lower concentration of source countries. The value reported in Table 55 refers to the supply risk at mine stage.

The economic importance increased in comparison to the 2017 assessment. This is a consequence of the sector-specific economic development in the EU since 2017, reflected in altered value added in the sectors, for which fluorospar was important.



**Table 55: Economic importance and supply risk results for fluorspar in the assessments of 2011, 2014, 2017, 2020 (European Commission, 2011-2014-2017)**

Assessment	2011		2014		2017		2020	
Indicator	EI	SR	EI	SR	EI	SR	EI	SR
Fluorspar	7.5	1.63	7.18	1.72	4.2	1.3	3.34	1.27

## 9.7 Data sources

Data for the production of processed fluorspar in HF, cyrolite, and aluminium fluoride are not available at global level. Therefore, the calculation of the supply risk indicator at processing stage was done using the EU-28 HHI only.

### 9.7.1 Data sources used in the factsheet

BGS (2011). Mineral Planning Factsheet - Fluorspar, [online] Available at: <https://www.bgs.ac.uk/downloads/start.cfm?id=1405> [Accessed August 2016].

Bio Intelligence Service (2015). Study on Data for a Raw Material System Analysis: Roadmap and Test of the Fully Operational MSA for Raw Materials – Final Report. Prepared for the European Commission, DG GROW

CRM Alliance (2016) Personal communication during the review. DERA (2019). Mineral Price Monitor. [https://www.deutsche-rohstoffagentur.de/SharedDocs/GT\\_Produkte/Mineral\\_Rohstoffe/volatilitaetsmonitor\\_all-genTab\\_DE.html?nn=5091242](https://www.deutsche-rohstoffagentur.de/SharedDocs/GT_Produkte/Mineral_Rohstoffe/volatilitaetsmonitor_all-genTab_DE.html?nn=5091242)

European Commission (2011). Critical raw materials for the EU. [online] Available at: [https://ec.europa.eu/growth/sectors/raw-materials/specific-interest/critical\\_en](https://ec.europa.eu/growth/sectors/raw-materials/specific-interest/critical_en)

European Commission (2014) Report on critical raw materials for the EU - Critical raw materials profiles. Germanium profile, p67-76.

European Commission (2017). Critical raw materials for the EU. [online] Available at: [https://ec.europa.eu/growth/sectors/raw-materials/specific-interest/critical\\_en](https://ec.europa.eu/growth/sectors/raw-materials/specific-interest/critical_en)

Eurostat (2019)a. International Trade Easy Comext Database [online] Available at: <http://epp.eurostat.ec.europa.eu/newxtweb/>

Eurostat (2019)b. Annual detailed enterprise statistics for industry (NACE Rev. 2, B-E). [online] Available at: [http://ec.europa.eu/eurostat/en/web/products-datasets/-/SBS\\_NA\\_IND\\_R2](http://ec.europa.eu/eurostat/en/web/products-datasets/-/SBS_NA_IND_R2)

Industrial Minerals Forum and Research (Imformed) (2018). Fluorine Forum 2018 Review- [online] Available at: <https://imformed.com/fluorspar-market-outlook-madrid-meet-hits-the-spot/>

Lauri, L. *et al.* (2018) *Identification and quantification of primary CRM resources in Europe. SCRREEN project D3.1.* Available at: <http://screen.eu/results/>.

MarketWatch Press Release (2019). Fluorspar markt size share 2019 (online) Available at: <https://www.marketwatch.com/press-release/fluorspar-market-size-share-2019-global-industry-trends-growth-factor-analysis-reginal-analysis-and-forecast-to-2024-2019-09-11>

Minerals4EU (2019). European Minerals Yearbook. [online] Available at: [http://minerals4eu.brgm-rec.fr/m4eu-yearbook/theme\\_selection.html](http://minerals4eu.brgm-rec.fr/m4eu-yearbook/theme_selection.html)

OECD (2019). Export restrictions on Industrial Raw Materials. [online] Available at: [http://qdd.oecd.org/table.aspx?Subject=ExportRestrictions\\_IndustrialRawMaterials](http://qdd.oecd.org/table.aspx?Subject=ExportRestrictions_IndustrialRawMaterials) [Accessed September 2019]

Roskill (2019). Roskill Market Report – Fluorspar. [online] Available at: <https://roskill.com/market-report/fluorspar/> [Accessed November 2016]

SCRREEN workshop. (2019). Validation Workshop on Critical Raw Materials, 10-12 September 2019, Thon Hotel Brussels City Centre.

Sundqvist Oeqvist, Pr. Lena et al. (2018). SCRREEN D4.2. Production Technologies of CRM from Primary Resources. Available at: <http://screen.eu/wp-content/uploads/2018/03/SCRREEN-D4.2-Production-technologies-of-CRM-from-secondary-resources.pdf>

The Chemours Company (2016). Communication during the workshop held in Brussels on 28/10/2016

UN Comtrade database (2019) [online]. Available at: <https://comtrade.un.org/>

USGS (2015). Minerals: Fluorspar. [online] Available at: <https://minerals.usgs.gov/minerals/pubs/commodity/fluorspar/mcs-2016-fluor.pdf> [Accessed 20 December 2016].

USGS (2016). Fluorspar. [online] Available at: <http://minerals.usgs.gov/minerals/pubs/commodity/fluorspar/280494.pdf> [Accessed 20 November 2016].

USGS (2018). Minerals: Fluorspar. [online] Available at: <https://minerals.usgs.gov/minerals/pubs/commodity/fluorspar/mcs-2018-fluor.pdf> [Accessed October 2019].

USGS (2019). Minerals: Fluorspar. [online] Available at: <https://minerals.usgs.gov/minerals/pubs/commodity/fluorspar/mcs-2019-fluor.pdf> [Accessed October 2019].

World Mining Data (2019). Bundesministerium für Wissenschaft, Forschung und Wirtschaft. Austrian Ministry of Science, Research and Economy. [online] Available at: [www.en.bmwf.gv.at/Energy/WorldMiningData/Seiten/default.aspx](http://www.en.bmwf.gv.at/Energy/WorldMiningData/Seiten/default.aspx)

### **9.7.2 Data sources used in the criticality assessment**

BGS (2011). Mineral Planning Factsheet - Fluorspar, [online] Available at: <https://www.bgs.ac.uk/downloads/start.cfm?id=1405> [Accessed August 2016].

Bio Intelligence Service (2015). Study on Data for a Raw Material System Analysis: Roadmap and Test of the Fully Operational MSA for Raw Materials – Final Report. Prepared for the European Commission, DG GROW

Espa, Ilaria (2015). Export Restrictions on Critical Minerals and Metals: Testing the Adequacy of WTO Disciplines. Cambridge University Press.

European Commission (2016). DG Trade. Agreements [online] Available at: <http://ec.europa.eu/trade/policy/countries-and-regions/agreements/>

European Commission (2017). Critical raw materials for the EU. [online] Available at: [https://ec.europa.eu/growth/sectors/raw-materials/specific-interest/critical\\_en](https://ec.europa.eu/growth/sectors/raw-materials/specific-interest/critical_en)

Eurostat (2019)a. International Trade Easy Comext Database [online] Available at: <http://epp.eurostat.ec.europa.eu/newxtweb/>

Eurofer (2016). Communication with Aurélio Braconi during the workshop held in Brussels on 28/10/2016

Huxtable (2016). Communication during the workshop held in Brussels on 28/10/2016

OECD (2019). Export restrictions on Industrial Raw Materials. [online] Available at: [http://qdd.oecd.org/table.aspx?Subject=ExportRestrictions\\_IndustrialRawMaterials](http://qdd.oecd.org/table.aspx?Subject=ExportRestrictions_IndustrialRawMaterials) [Accessed September 2019]

SCRREEN workshop. (2019). Validation Workshop on Critical Raw Materials, 10-12 September 2019, Thon Hotel Brussels City Centre.

The Chemours Company (2016). Communication during the workshop held in Brussels on 28/10/2016 with Frenk Huslebosch and Joachim Gerstel

UN Comtrade database (2019) [online]. Available at: <https://comtrade.un.org/>

World Mining Data (2019). Bundesministerium für Wissenschaft, Forschung und Wirtschaft. Austrian Ministry of Science, Research and Economy. [online] Available at: [www.en.bmwf.wg.at/Energy/WorldMiningData/Seiten/default.aspx](http://www.en.bmwf.wg.at/Energy/WorldMiningData/Seiten/default.aspx)

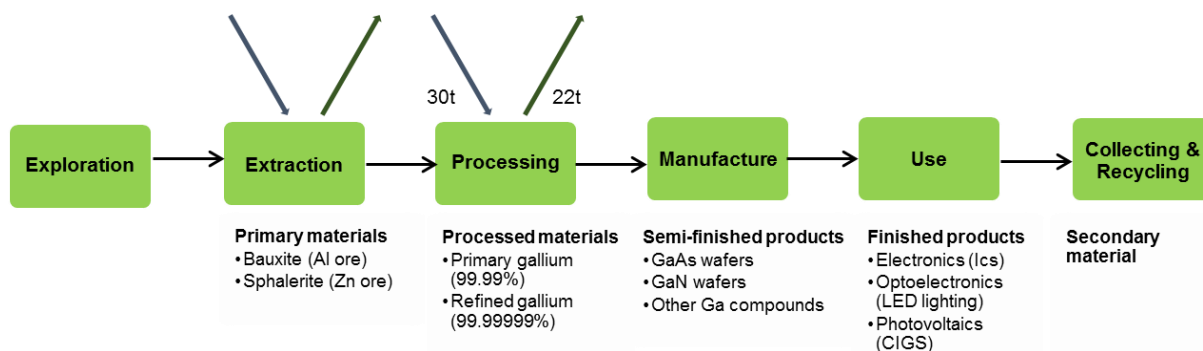
## **9.8 Acknowledgments**

---

This factsheet was prepared by the JRC. The authors would like to thank SCRREEN expert network, the EC Ad Hoc Working Group on Critical Raw Materials and all other relevant stakeholders for their contributions to the preparation of this Factsheet.

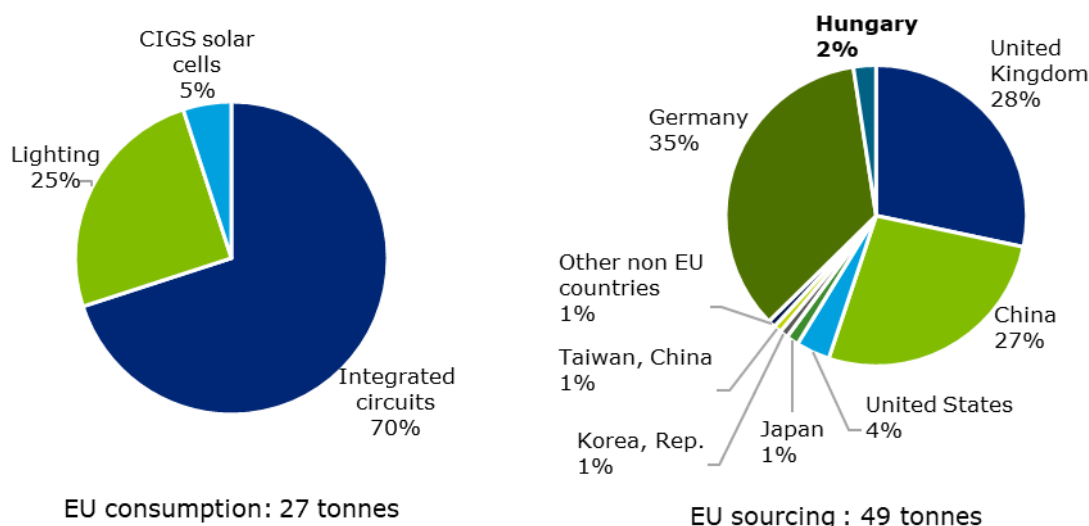
# 10 GALLIUM

## 10.1 Overview



**Figure 131: Simplified value chain for gallium<sup>90</sup>**

Gallium (chemical symbol Ga, from Gallia) is a soft, silvery-white metal. It is an excellent conductor of both electricity and heat, has a very low melting point (30°C), and is a magnetic material. Gallium’s abundance in the upper continental crust is 17.5 ppm, which is comparable to the one of lead (Rudnick and Gao 2013b). However, gallium does not occur in its elemental form in nature but mostly substitutes for other elements in certain minerals such as gallite (CuGaS<sub>2</sub>) (Butcher, 2014). The term “primary gallium” in this factsheet (or its synonyms “virgin gallium”, or “crude gallium”) refers to the gallium metal of a purity of 3N (99.9%) or 4N (99.99%) obtained after the first steps of processing. “Refined gallium” refers to a purity of 6N (99.9999%) or 7N (99.99999%) obtained after further processing (European Commission 2017b). The main commercial form of gallium is 4N gallium metal.



**Figure 132: End uses of primary gallium metal (SCREEN, 2019) in the EU and EU sourcing of primary gallium metal<sup>91</sup>, annual average 2012-2016**

<sup>90</sup> In the [Study on the review of the list of critical raw materials 2017](#), the estimated amount of gallium resource in the EU was 21,400 t; a figure that needed to be interpreted with caution.

<sup>91</sup> The import figure from UK may refer to refined gallium, not primary. The term “primary gallium” in this factsheet (or its synonyms “virgin gallium”, or “crude gallium”) refers to the gallium metal of a purity of 3N (99.9%) or 4N (99.99%) obtained after the first steps of processing.

This assessment focuses on primary gallium (Trade code CN 81129289 for “Unwrought Gallium, Gallium powders”). As a by-product of other metals (mainly aluminium and zinc), the supply risks of gallium availability is related to the capacities for its recovery.

Gallium is not traded on any metals exchange, and there are no terminal or futures markets where buyers and sellers can fix an official price. The prices are negotiated bilaterally between suppliers and customers on a long term base (Huy, D and Liedtke, M. ,2016). Between 2010-2014, the quantity of unwrought gallium exported to the global market was estimated at about 170-200 tonnes per year (Huy, D and Liedtke, M. ,2016). The prices of primary gallium (purity <99.99%) varied from USD 188 and USD 349 per kg in between 2012 and 2016 (BGR, 2020). According to USGS, refined gallium with a (purity of >99.9999%) prices varied between USD 529 per kg to USD 690 per kg in the period 2012-2016.

The EU consumption of primary gallium over the period 2012-2016 was estimated at 26.9 tonnes per year, which was fulfilled through imports and domestic production. United Kingdom, China and United States were the main suppliers of primary gallium into the EU. Between 2012 and 2016, the EU production of gallium occurred in Germany and Hungary. The EU was a net importer of gallium with 31% of import reliance.

Gallium is used in high-tech application. The main compounds of gallium, representing 94% of consumption are gallium arsenide (GaAs) and gallium nitride (GaN) (Huy, D and Liedtke, M. ,2016). These compounds are mostly used in semiconductors and optoelectronics. As for many minor metals, gallium has specific properties which make it unique in its main applications. Nevertheless, in case of disruption or price constraints, some alternative technologies or materials can usually substitute, often at lower cost but with loss of performances.

Given its use in photovoltaics, gallium can play a role in enabling low-carbon energy solutions in the EU economy, contributing to achieve the objectives of the “European strategic long-term vision for a prosperous, modern, competitive and climate neutral economy”.<sup>92</sup>

There is no mining extraction of gallium in the EU. Gallium is rarely found in sufficient quantities by itself to enable economic extraction and is extracted as a by-product of aluminium production, and to a much a lesser degree, of zinc production. Being a by-product, the estimation of gallium resource is linked to bauxite and zinc resource. According to USGS estimates in 2019, gallium contained in world resources of bauxite would exceed 1 million tonnes, with a considerable quantity potentially contained in world zinc resources (USGS, 2019). Nevertheless, only less than 10% is potentially recoverable from these resources. In 2011, Indium Corporation estimates of gallium resources were more conservative with 760,000 tonnes worldwide (European Commission, 2014a). In Europe, bauxite resources are reported as being present in many countries such as Bulgaria, France, Germany, Greece, Hungary, Italy, or Romania (Minerals4EU, 2019) representing potential gallium resources.

The average world annual production of primary gallium over 2012-2016 reached a quantity of 214.5 tonnes per year with 81% of production in China (WMD, 2019). The EU production of primary gallium was reported at 19 tonnes per year from Germany and 1.6 tonnes per year from Hungary during the same period (World Mining Data, 2019). However, the gallium production in Hungary stopped in 2013 (Fekete, 2019).

At present, no gallium is recovered from post-consumer scrap (Huy, D and Liedtke, M. ,2016). The rate of recovery of gallium from end-of-life products reported by UNEP is near

---

<sup>92</sup> COM(2018) 773 final A Clean Planet for all. A European strategic long-term vision for a prosperous, modern, competitive and climate neutral economy

0% (UNEP, 2011). The low recovery rate of gallium is due to the difficulty and cost to recover it in items where it is highly dispersed.

Since 2014, gallium arsenide is mentioned in Annex XVII to REACH regulations in the category carcinogenic, mutagenic or reprotoxic substances. However, none of gallium compounds is on the list of substances of very high concern (ECHA, 2014). Globally, there were no trade restrictions imposed on gallium in the year 2012-2016 (OECD, 2019).

## 10.2 Market analysis, trade and prices

### 10.2.1 Global market analysis and outlook

In general, data on the global trade of gallium are difficult to obtain as they are often incomplete and partially contradictorily. From 2010 to 2014, the quantity of unwrought gallium exported to the global market was estimated at about 170-200 tonnes per year (Huy, D and Liedtke, M. ,2016).

China remained the major producer of primary and refined gallium over the period 2012-2016. The primary gallium production capacity of China was estimated at 550 tonnes in 2014, mostly from alumina production and 170 tonnes from upgrading and recycling of gallium (Huy, D and Liedtke, M. ,2016). At company level, the Chinese company Zhuhai SEZ Fangyuan Inc. was among the major producers of primary gallium with annual production capacity of 140 tonnes, as reported by Huy, D and Liedtke, M. , (2016).

Between 2010 and 2015 Chinese capacity for primary gallium has grown from 140 tonnes per year to 600 tonnes per year, in expectation of growing demand for GaN LEDs for backlighting in tablet computers, mobile phones and TVs. As a consequence, the large surplus of primary gallium from China would most likely restrict output non-China producers of gallium, such as Japan, the Republic of Korea, Russia, and Ukraine (USGS, 2018).

Apart from China, the production capacities for primary gallium is estimated at 120 tonnes by December 2016, distributed in Germany, Kazakhstan, South Korea, Ukraine, Russia, Japan, and Hungary (USGS, 2016).

At refining stage, the main producers of refined gallium from primary material were China, Japan, the United Kingdom, the United States, and Canada (see section Refining and purification and gallium).

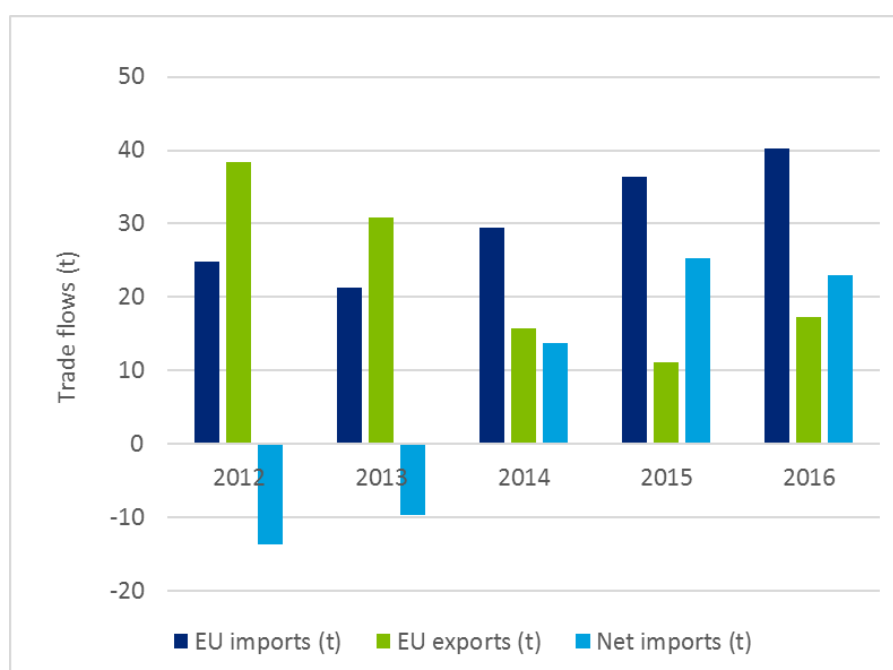
Growing demand in all sectors of the semiconductors/semi-insulator market will lead to increasing consumption of gallium in the coming years (Huy, D and Liedtke, M. ,2016). Integrated circuits would most likely still drive most of the future gallium demand towards 2035. A slight upward trend of gallium demand should be expected. The main drivers of future demand of gallium used smartphones and computers in this study are among others, growth of demand related to social needs (on-line social network, applications, etc), the trend for smaller and more integrated devices (Monnet, 2018).

**Table 56: Qualitative forecast of supply and demand of primary gallium**

Materials	Criticality of the material in 2020		Demand forecast			Supply forecast		
	Yes	No	5 years	10 years	20 years	5 years	10 years	20 years
Gallium	X		+	+	+	?	?	?

## 10.2.2 EU trade

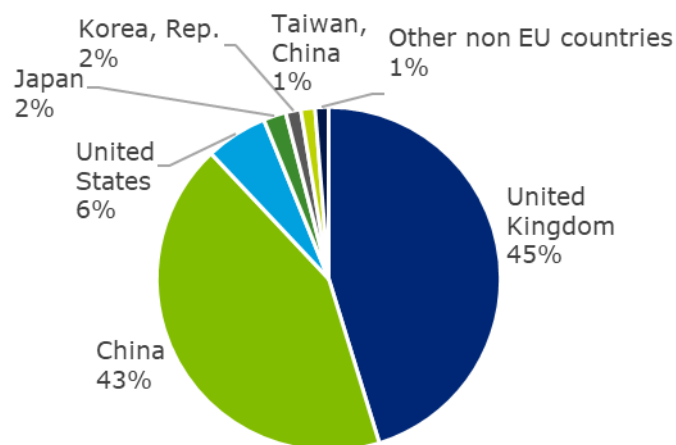
The EU changed from being a net exporter of primary gallium in 2012-2013 to a net importer in 2013-2016 (Figure 133). The EU import reliance of primary gallium was estimated at 31% (average of 2012-2016). The production in Hungary stopped in 2013. In 2016 Germany stopped its production due to high operating costs and cheap Chinese material available.



**Figure 133: EU trade flows for gallium CN8 code 81129289 (Eurostat, 2019a)**

Based on the trade data from Eurostat Comext, CN8 code 81129289 (Unwrought Gallium; Gallium powders), China and the United Kingdom were by far the first source of EU supply for this period (Figure 133). However, according to expert, the UK exported refined gallium produced from the German primary gallium (BGR, 2019).

In smaller quantities, the following countries also supplied primary gallium to the EU in 2012-2016: United States, Japan, Korea, Canada. For some countries like United States, Canada or Russia, imports include secondary material (new scraps) for treatment within the EU. There was no export restrictions targeting gallium from the supplying countries to the EU during the period 2012-2016 (OECD, 2019).



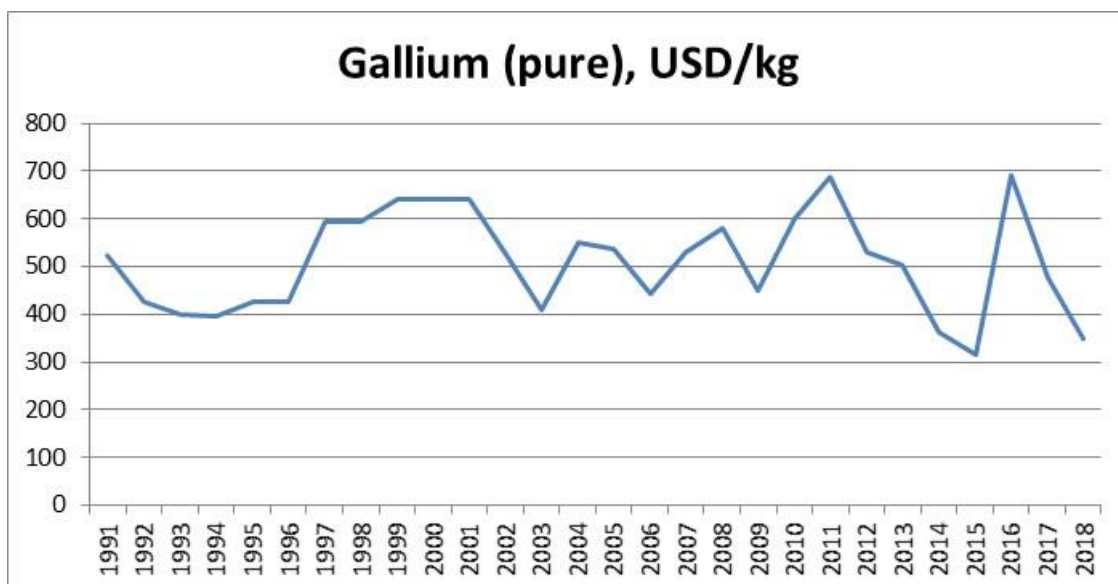
EU imports : 31 tonnes

**Figure 134: EU imports of primary gallium CN8 code 81129289. Average 2012-2016 (Eurostat-Comext, 2019)**

### 10.2.3 Prices and price volatility

Gallium is not traded on any metals exchange, and there are no terminal or futures markets where buyers and sellers can fix an official price. Gallium prices are negotiated bilaterally on a long term base between suppliers and customers (Huy, D and Liedtke, M., 2016). References for prices are obtained through averages of past deals between private parties, generally available through paid subscription (e.g. Asian Metal, Metal Pages).

Figure 135 shows the trend of prices of high purity 7N gallium (99.99999%). In 2011 gallium 7N price reached USD 688 per kg. Since then, there was a progressive decrease to USD 318 per kg in 2015, in great part due to oversupply in China.



**Figure 135: Gallium price trend (purity min. 99.99999 %) (Data from USGS)**



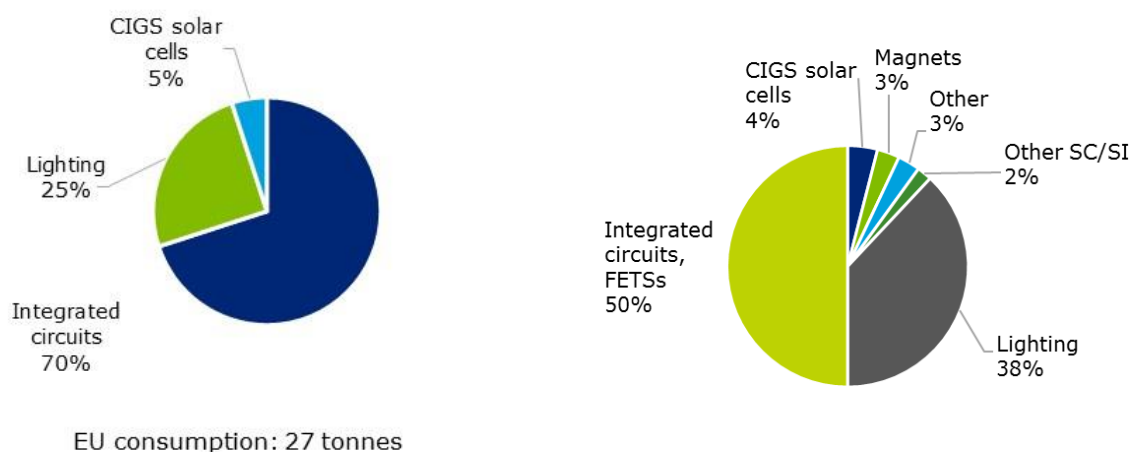
## 10.3 EU demand

### 10.3.1 EU demand and consumption

Apparent consumption figures (EU production + EU imports - EU exports) are not reliable due to uncertainties related to the share of gallium produced, traded, or integrated in finished goods at all levels. CN code used for the EU supply is 81129289 (Unwrought Gallium; Gallium powders). These figures may include secondary gallium (new scraps) for some countries like United States, Canada, Russia (European Commission, 2017).

### 10.3.2 Uses and end-uses of gallium in the EU

The final end-uses of gallium in the EU has not changed since 2010-2014. It can be estimated that 70% of gallium consumption has been for Integrated Circuits (ICs), 25% for lighting applications (mostly LED technology) and around 5% in the Copper-Indium-Selenium-Gallium photovoltaic technology (USGS, 2015; Mikolajczak, 2016)(Figure 136).



**Figure 136: EU end uses of gallium average 2012-2016) (left) (SCREEN, 2019) and global end uses of gallium (right) (data source: USGS, 2019)**

The most common gallium compounds used in semiconductors technology are gallium arsenide (GaAs) (92%), gallium nitride (GaN) (8%) (BRGM, 2016). One of the reasons why GaN is produced in reduced quantities is that GaAs is composed of two metals whereas GaN is formed from a metal and a gas, which is much more difficult and costly to make. Different end-uses require different qualities of substrate crystal, with integrated circuits (ICs) and microwave devices requiring the highest quality.

In integrated circuits application, a few examples of electronic devices where Integrated Circuits are critical components include:

- Mobile phones; mostly in Power Amplifiers (PAs). The PAs in a mobile phone are the vital components that amplify signals, both voice and data, to the appropriate power level for them to be transmitted back to the network base-station. The more advanced the generation used (3G, 4G), the more PAs it needs;
- Wireless communication systems; where semiconductors are employed in a number of different contexts (fibre optics, sensors, etc.);
- Military applications; for radar, satellite, night vision or communication high performance devices.

In lighting, semiconductors are used in an optoelectronic capacity, because of their ability to convert electrical input into light output. Some of their main applications are Infrared Emitting Diodes (IREDs), Laser Diodes (LDs) and Light Emitting Diodes (LEDs); the latter being one of the fastest growing markets in the past few years (Grady, 2013).

In photovoltaics, gallium’s main use is Copper-Indium-Selenium-Gallium (CIGS) technology. It is a thin-film technology that involves the deposition of a thin layer, only a few micrometres deep, of semiconducting material on various different surfaces. However, since 2010, the market for this technology has dropped, the vast majority of solar cells for terrestrial applications using crystalline silicon (c-Si, both mono- and multi-crystalline) technology (Fraunhofer, 2016). CIGS technology is preferred for specific terrestrial applications where flexibility is required (Butcher, 2014). Quantities of gallium currently used in solar-cell production thus remain small.

Other end-uses for gallium metal or chemicals include eutectic alloys, pharmaceutical compounds (gallium nitrate) or NdFeB magnets (wher Ga can be added in small quantities to improve magnetic properties and corrosion resistance), which remain minor at the industrial level.

Figure 136 reflects the global end-uses of gallium, which includes also the shares of these “other end-uses”. Relevant industry sectors for gallium, described using the NACE sector codes, are reported in Table 57.

**Table 57: Gallium applications, 2-digit and associated 4-digit NACE sectors, and value added per sector (Eurostat, 2019b)**

<b>Applications</b>	<b>2-digit NACE sector</b>	<b>4-digit NACE sectors</b>	<b>Value added of NACE 2 sector (M€)</b>
Integrated circuits	C26 - Manufacture of computer, electronic and optical products	C2610- Manufacture of electronic components	65,703
Lighting	C27 - Manufacture of electrical equipment	C2740-Manufacture of electric lighting equipment	80,745
CIGS solar cells	C26 - Manufacture of computer, electronic and optical products	C2610- Manufacture of electronic components	65,703

### 10.3.3 Substitution

In semiconductors, silicon or silicon-based substrates are usually the main substitutes for GaAs or GaN substrates, such as SiGe (CRM InnoNet, 2015). But it can only be for a limited number of applications, as silicon presents a lesser electron mobility and is therefore significantly less efficient. GaAs-based semiconductors also operate at higher breakdown voltages and generate less noise at high frequencies (>250 MHz). Pure GaAs substrates finally have the great advantage of being semi-insulating, whilst silicon substrates are semiconducting.

In lighting, LEDs present many advantages such as their low-energy consumption, non-toxicity, and longevity (up to 100,000 hours). Organic LED (OLED) could be a substitute to solid state LED but so far, they are not competitive in terms of price and durability (CRM InnoNet, 2015).

In photovoltaics, Crystalline silicon technologies currently represent more than 90% of the market for terrestrial applications, even though conversion efficiency is reduced from 18-22% to 8-15% when silicon is used rather than CIGS in photovoltaic cells. Other thin film technologies include cadmium telluride (CdTe) and copper indium selenide (CIS) (Fraunhofer, 2016).

## 10.4 Supply

---

### 10.4.1 EU supply chain

The EU supply chain of gallium is quite mature; players adapt to market conditions.

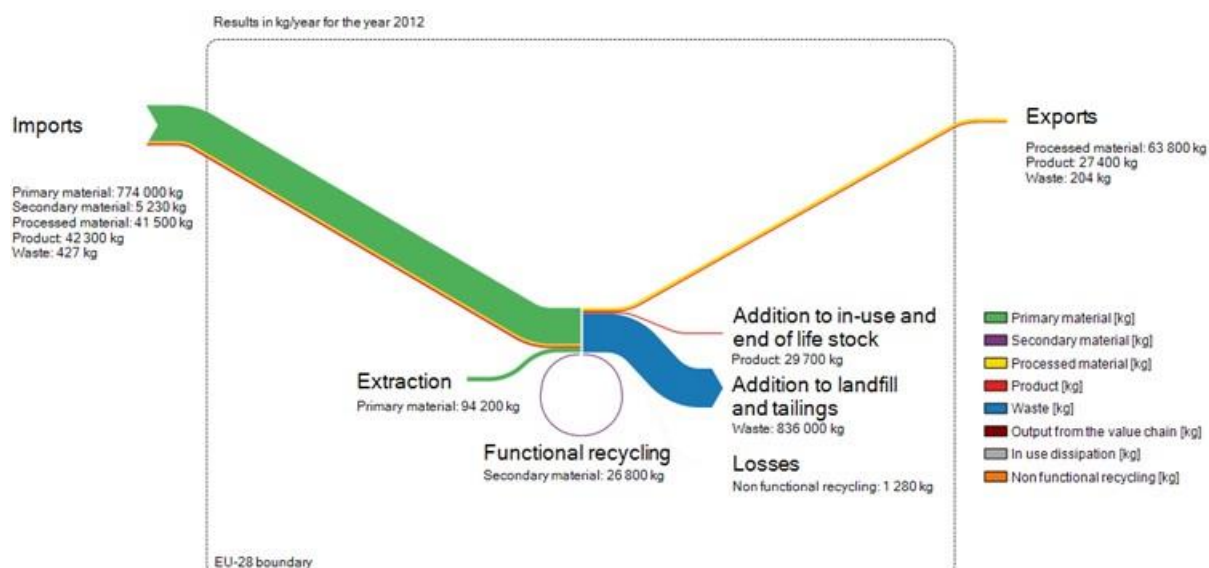
All levels of the gallium supply chain are present in the EU:

- Based on the annual production figure in World Mining Data (2019), the average EU production of primary gallium over the years 2012-2016 was estimated at 19 tonnes per year. Between 2012 and 2016, the EU production mainly took place in Germany (17 tonnes per year) and for a minor quantity (approximately 1 tonne per year), in Hungary, accounting for a total of 9% of global primary gallium supply. The production of both countries have reportedly stopped. Inga Stade GmbH, Germany's sole producer of primary gallium, stopped their production in 2016. The primary gallium produced by Inga Stade was shipped to the refining in the UK and in the USA to further treat primary gallium up to 7N purity (Monnet, 2018). The production in Hungary stopped in 2013 (Huy, D and Liedtke, M. ,2016). Hungary's production came from crude gallium extraction from Bayer liquor with a purit of 4N to 7N. The estimated capacity of production in Hungary reached 8 tonnes per year. In the past, there was also production of primary gallium in Slovakia, however, it stopped in 2010. Despite its production, the EU remained dependent on its foreign imports of primary gallium for the period 2012-2016. The average annual EU import of primary gallium in the period 2012-2016 was approximately 31 tonnes. On the other hand, EU exports of primary gallium was 22.7 tonnes. The EU import reliance of primary gallium was 32%.
- At processing stage, some of the few companies in the world producing refined high-purity gallium (6N or 7N) are located in the EU, for example CMK<sup>93</sup> in Slovakia and PPM Pure Metals<sup>94</sup> in Germany ).
- At manufacturing stage, there are processors and wafer manufacturers in Germany (e.g. Freiburger Compound Materials) and in Belgium (Umicore, which commercializes trimethylgallium). Both companies are suppliers of downstream European microelectronic and optoelectronic industrials.
- At recycling stage, some manufacturers are also active in closed-loop recycling, with facilities often located abroad. Intra-companies material transfers are frequent in this activity. Part of gallium consumption also occurs in the form of imported manufactured products.

---

<sup>93</sup> <http://cmk.sk/>

<sup>94</sup> <http://www.pppuremetals.de>



**Figure 137: Simplified sankey diagram of material system analysis of gallium (reference year 2012) (BIOIntelligence, 2015)**

## 10.4.2 Supply from primary materials

### 10.4.2.1 Geology, resources and reserves of gallium

**Geological occurrence:** Gallium is not found in its elemental form and does not form economically recoverable concentrations. Gallium is almost exclusively obtained as by-product during the processing of other metals, mainly aluminium and zinc (Huy, D and Liedtke, M., 2016).

#### *Recovery as a by-product of aluminium processing*

The production of gallium from bauxite, the main ore of aluminium, is the primary source of supply. Gallium is present in bauxite as a trace element. It would originate from minerals such as feldspar or nepheline (Deschamps et al., 2002). Both aluminium and gallium are released from these minerals during weathering processes and their similar geochemical properties result in the enrichment of both elements in bauxite (Dittrich et al., 2011). The ratio of gallium to aluminium, and therefore the concentration of gallium, in bauxite increases with greater intensity of weathering. Gallium also appears to be more abundant where the bauxite was derived from alkali source rocks (Weeks, 1989). The gallium content in bauxite can vary from 10 to 160 ppm (Mordberg et al., 2001; Bhatt, 2002). On average, it is reported to be 57 ppm (Schulte and Foley, 2014).

#### *Recovery as a by-product of zinc processing*

Gallium concentrations in the zinc ore, sphalerite, are known to increase as the temperature of deposition decreases, although it can still be present in intermediate and higher-temperature deposit types (Stoiber, 1940; Cook et al., 2009).

In the hydrometallurgical route for zinc production, zinc oxide is first produced by roasting the zinc sulphide (sphalerite). The gallium-bearing zinc oxide is then leached with sulfuric acid to produce a zinc sulphate solution. The impurities, which include gallium, are removed through the addition of antimony or arsenic trioxide, zinc dust or proprietary reagents. The gallium is then extracted from the resulting separated solids or 'cement residues' by electrolysis (Butcher, 2014). In 2011, this source accounted for less than 1% of total gallium supply (Roskill, 2011).

**Global resources and reserves**<sup>95</sup> According to USGS (2019) estimates, gallium contained in world resources of bauxite would exceed 1 million tonnes, with a considerable quantity also potentially contained in world zinc resources. Quantitative estimates of reserves were not available (USGS, 2019)

#### **EU resources and reserves**<sup>96</sup>

In the Minerals4EU (2019) project, no quantitative information was reported concerning gallium. Bauxite resources are reported as being present in many EU countries such as Bulgaria, France, Germany, Greece, Hungary, Italy, or Romania representing potential gallium resources. There has not been any updates of the information in Minerals4EU.

The only existing estimates of EU gallium resources are provided in the 2014 criticality assessment at 21,400 tonnes, a quantity based on identified bauxite deposits (Moss R.L. et. a., 2011). This number should be interpreted with appropriate caution though, as it does not comply with international standards of reporting (UNFC) and is very likely to be overestimated, as well as being uneconomic in current market conditions.

#### **10.4.2.2 World and EU mine production**

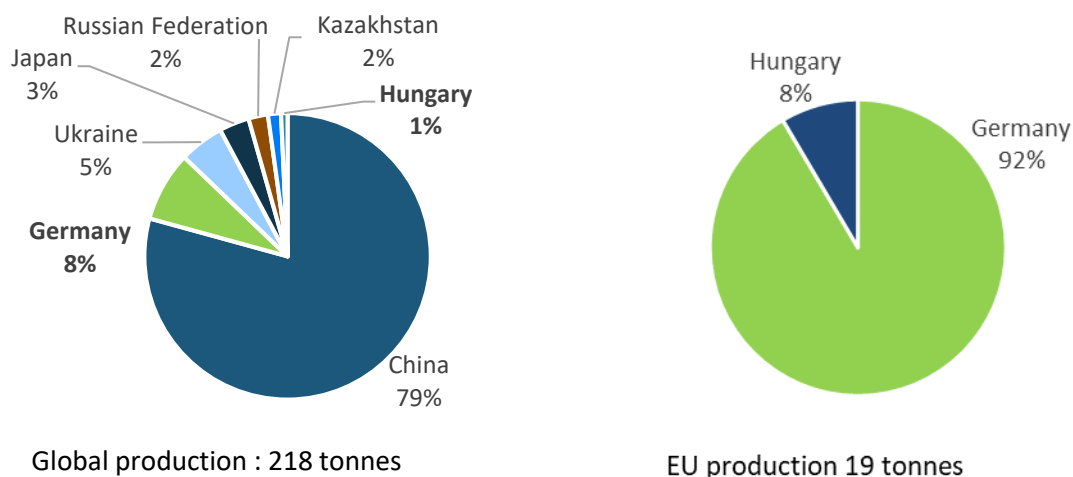
The annual global production of primary gallium between 2012 and 2016 was estimated at 218 tonnes by the World Mining Data (2019).

Primary gallium production is known to have increased between 2012 and 2014, in large part due to major expansion of both capacity and output in China. The overcapacity from China led many producers other than Chinese to stop their gallium operations during this period.

---

<sup>95</sup> There is no single source of comprehensive evaluations for resources and reserves that apply the same criteria to deposits of gallium in different geographic areas of the EU or globally. The USGS collects information about the quantity and quality of mineral resources but does not directly measure reserves, and companies or governments do not directly report reserves to the USGS. Individual companies may publish regular mineral resource and reserve reports, but reporting is done using a variety of systems of reporting depending on the location of their operation, their corporate identity and stock market requirements. Translations between national reporting codes are possible by application of the CRIRSCO template.<sup>95</sup>, which is also consistent with the United Nations Framework Classification (UNFC) system. However, reserve and resource data are changing continuously as exploration and mining proceed and are thus influenced by market conditions and should be followed continuously.

<sup>96</sup> For Europe, there is no complete and harmonised dataset that presents total EU resource and reserve estimates for gallium. The Minerals4EU project is the only EU-level repository of some mineral resource and reserve data for gallium, but this information does not provide a complete picture for Europe. It includes estimates based on a variety of reporting codes used by different countries, and different types of non-comparable datasets (e.g. historic estimates, inferred reserves figures only, etc.). In addition, translations of Minerals4EU data by application of the CRIRSCO template is not always possible, meaning that not all resource and reserve data for gallium the national/regional level is consistent with the United Nations Framework Classification (UNFC) system (Minerals4EU 2019). Many documented resources in Europe are based on historic estimates and are of little current economic interest. Data for these may not always be presentable in accordance with the UNFC system. However a very solid estimation can be done by experts.



**Figure 138: Global (left) and EU (right) mine production of primary gallium in tonnes and percentage. Average for the years 2012-2016. (WMD, 2019)**

The EU production occurred in Germany and Hungary, accounting for an average 19 tonnes per year from 2012 to 2016.

According to company reports, Hungarian production stopped in 2013 (MAL Magyar Alumínium Termelő). The production in Germany (Dadco Alumina) stopped in 2016.

### 10.4.3 Supply from secondary materials/recycling

At present, no gallium is recovered from post-consumer scrap (Huy, D and Liedtke, M., 2016). The rate of recovery of gallium from end-of-life products is near 0% (UNEP, 2013).

The low recovery rate of gallium is due to the difficulty and cost to recover gallium in items where it is highly dispersed. Gallium in its major application, semiconductor devices such as integrated circuits (ICs) and light emitting diodes (LEDs), is used in a few microns thick deposition layer on top of a much thicker substrate and therefore require very little gallium per device (Weimar, 2011). Current recycling processes of waste electrical and electronic equipment in which they are contained rather favour the recovery of precious metals or copper, while gallium ends up as an impurity in recycled metals or in waste slags (UNEP, 2013).

However, as for many other metals, pre-consumer recycling (i.e. from industrial scrap) is more common source of secondary supply for gallium. The manufacture processes of gallium arsenide (GaAs) and gallium nitride (GaN) wafers are estimated to be the metal's most important secondary source, with some 60% scrap generated and recycled in a 'closed loop' (Butcher, 2014). As for gallium used in thin film photovoltaic production, CIGS technology in particular, material yields assuming sputtering deposition is typically 30-60%, which also allow material recovery and recycling (Marwede, 2014).

Worldwide production capacity of secondary gallium is estimated at 200 t (Huy, D and Liedtke, M., 2016). In the United States, high/purity gallium new scrap is known to be recovered from GaAs-based devices (USGS, 2019). There are a few companies in the EU with operations for Ga recycling, for example CMK in Slovakia, who refined from low purity primary gallium (3N, 4N) and from recycled waste material containing gallium (gallium arsenide, chloride, oxide). The recycling and refining capacities was reported at 25 tonnes per year for the years 2006 – 2009 (Huy, D and Liedtke, M., 2016).

## 10.4.4 Refining and purification of gallium

Optoelectronic applications generally require gallium (and arsenic) of at least 6N purity (99.9999%) and electronic applications require 7N purity metal. Purities of 6N or 7N are achieved by gradual crystallization of liquid gallium. Two methods exist and rely on the fact that impurities tend to remain in the liquid phase and cannot contaminate the growing crystal. There are many impurities of concern such as Ca, C, Cu, Fe, Mg, Ni, Se, Si, Sn, Te. Concentrations of these elements should be less than 1 ppb in the gallium (and arsenic) used for GaAs semiconductors manufacture. Lead, mercury and zinc concentrations must also be lower than 5 ppb. Mass spectrometry is used to analyse final high purity gallium for such impurities (Roskill, 2011).

The capacity for refining gallium into high-purity gallium (6N or 7N) worldwide is estimated at around 160 tonnes according to USGS and it is and less concentrated in China. It is only mastered by a few companies, some of them located in the EU, for example, CMK<sup>97</sup> in Slovakia and PPM Pure Metals in Germany<sup>98</sup>.

## 10.5 Other considerations

---

### 10.5.1 Environmental and health and safety issues

Since 2014, gallium arsenide has been mentioned in Annex XVII to REACH regulations in the category carcinogenic, mutagenic or reprotoxic substances. However, none of gallium compounds is on the list of substances of very high concern (ECHA, 2014).

## 10.6 Comparison with previous EU assessments

---

The assessment has been conducted using the same methodology as for the 2017 list. The results for both economic importance and supply risk for gallium stayed relatively stable compared to 2017's result. Therefore, the change in economic importance was caused by the difference in value added figures by sector since the end-use application remained the same compared to criticality assessment 2017.

The slight change in supply risk might have been influenced by the increasing production from China, raising from 73% of global supply to 79% over the year 2012-2016. The absence of production from Hungary has also influenced the increasing score of supply risk. The results of criticality assessment 2020 and of the earlier assessments are shown in Table 58.

**Table 58: Economic importance and supply risk results for Gallium in the assessments of 2011, 2014, 2017 and 2020 (European Commission, 2011; European Commission, 2014; European Commission, 2017)**

Assessment	2011		2014		2017		2020	
	EI	SR	EI	SR	EI	SR	EI	SR
Gallium	6.5	2.5	6.3	1.8	3.2	1.2	3.47	1.26

---

<sup>97</sup> <http://cmk.sk>

<sup>98</sup> [www.pppuremetals.de](http://www.pppuremetals.de)

## 10.7 Data sources

---

### 10.7.1 Data sources used in the factsheet

Bhatt, C.K. (2002). Estimation of gallium in a bauxite-ore deposit using an energy-dispersive X-ray fluorescence technique. *Radiation Physics and Chemistry* 65, 193–197.

BGR (Bundesanstalt für Geowissenschaften und Rohstoffe) (2019). Personal communication during CRM review process

BGR (Bundesanstalt für Geowissenschaften und Rohstoffe) (2020). Personal communication during CRM review process  
Bio Intelligence Service (2015). Study on Data for a Raw Material System Analysis: Roadmap and Test of the Fully Operational MSA for Raw Materials – Final Report. Prepared for the European Commission, DG GROW

BRGM (2016). Fiches de criticité - Le gallium, éléments de criticité. [online] Available at : [www.mineralinfo.fr/page/fiches-criticite](http://www.mineralinfo.fr/page/fiches-criticite)

Butcher T., Brown T. (2014). Gallium. In *Critical Minerals Handbook*. ed. G. Gunn. Publisher J. Wiley & Sons. Chapter 7, pp 257-305.

Cook, N.J., Ciobanu, C.L., Pring, A. Skinner, W., Shimizu, M., Danyushevsky, L., Saini-Eidukat, B. and Melcher, F. (2009). Trace and minor elements in sphalerite: a LA-ICPMS study. *Geochimica et Cosmochimica Acta* 73, 4761–4791.

CRM InnoNet (2015). Critical Raw Materials Substitution Profiles\_Gallium. <http://www.criticalrawmaterials.eu/documents/>

Cui, R., Guo, J., Yin, L., Huy, D., Liedtke, M. (2016). Supply and Demand of Lithium and Gallium. P. 28 – 50. ISBN 978-3-943566-33-8. Bundesanstalt für Geowissenschaften und Rohstoffe - BGR, Hannover, Germany.

Deschamps Y., Bailly L., Bouchot V., Gentilhomme P., Hocquard C., Lerouge C., Milesi J.P., Nicol N., Ollivier P., Pelon R., Salpeteur I. avec la collaboration de Save M., Thomassin J.F. (2002). Métaux rares à forte demande industrielle. Tantale, germanium, indium et gallium. Etat de l'art en économie, traitement des minerais, gîtologie. Rapport BRGM/RP-51558-FR, 284 p. 22 fig., 45 tabl., 32 ann.

Dittrich, T., Seifert, T. and Gutzmer, J. (2011). Gallium, can future demand be met by geological and technological availability? Department of Mineralogy, Technische Universität Bergakademie Freiberg, Germany.

ECHA (2014). Gallium arsenide. European Chemicals Agency. [online] Available at: <https://echa.europa.eu/substance-information/-/substanceinfo/100.013.741>

European Commission (2011). Critical raw materials for the EU. [online] Available at: [https://ec.europa.eu/growth/sectors/raw-materials/specific-interest/critical\\_en](https://ec.europa.eu/growth/sectors/raw-materials/specific-interest/critical_en)

European Commission (2014)a. Report on Critical Raw Materials for the EU. Critical Raw Materials Profiles [online] Available at: [https://ec.europa.eu/growth/sectors/raw-materials/specific-interest/critical\\_en](https://ec.europa.eu/growth/sectors/raw-materials/specific-interest/critical_en)

European Commission (2017). Report on Critical Raw Materials for the EU. Critical Raw Materials Profiles [online] Available at: [https://ec.europa.eu/growth/sectors/raw-materials/specific-interest/critical\\_en](https://ec.europa.eu/growth/sectors/raw-materials/specific-interest/critical_en)

Eurostat (2019)a. International Trade Easy Comext Database [online] Available at: <http://epp.eurostat.ec.europa.eu/newxtweb/>



Eurostat (2019)b. Annual detailed enterprise statistics for industry (NACE Rev. 2, B-E). [online] Available at: [http://ec.europa.eu/eurostat/en/web/products-datasets/-/SBS\\_NA\\_IND\\_R2](http://ec.europa.eu/eurostat/en/web/products-datasets/-/SBS_NA_IND_R2)

Fekete, Istvan, (2019) personal communication in September 2019.

Fraunhofer (2016). Photovoltaics report - Fraunhofer Institute for Solar Energy Systems (ISE). November 2016. [online] Available at: <https://www.ise.fraunhofer.de/de/downloads/pdf-files/aktuelles/photovoltaics-report-in-englischer-sprache.pdf>

Grady T., Thompson K., Crow A. M., Ridsdale D. (2013) LED Spotlight. Edison Investment Research. London, UK [online] Available at: [www.edisoninvestmentresearch.com/sectorreports/LEDreportJune2013.pdf](http://www.edisoninvestmentresearch.com/sectorreports/LEDreportJune2013.pdf)

Marwede M., Reller A. (2014). Estimation of life cycle material costs of cadmium telluride- and copper indium gallium diselenide-photovoltaic absorber materials based on life cycle material flows. *J. Ind. Ecol.* 2014,18 (2), 254–267.

Mikolajczak C. (2016). Indium Corporation, communication during the CRM workshop held in Brussels on 06/11/2016.

Minerals4EU (2019). European Minerals Yearbook. [online] Available at: [http://minerals4eu.brgm-rec.fr/m4eu-yearbook/theme\\_selection.html](http://minerals4eu.brgm-rec.fr/m4eu-yearbook/theme_selection.html)

Monnet, A., Abderrahim, A.A. (2018). Report on major trends affecting future demand for critical raw materials. SCRREEN D2.2. Available online at: <http://www.screen.eu/wp-content/uploads/2018/07/D2.2-Report-on-major-trends-affecting-future-demand-for-critical-raw-materials.pdf>

Mordberg, L.E., Stanley, C.J., Germann, K. (2001). Mineralogy and geochemistry of trace elements in bauxites: the Devonian Schugorsk deposit, Russia. *Mineralogical Magazine* 65 (1) 81–101.

Moss, R L, E Tzimas, H Kara, P Willis, and J Kooroshy. 2011. "Critical Metals in Strategic Energy Technologies. Assessing Rare Metals as Supply-Chain Bottlenecks in Low-Carbon Energy Technologies." Institute for Energy and Transport IET.

OECD (2019). Export restrictions on Industrial Raw Materials. [online] Available at: [http://qdd.oecd.org/table.aspx?Subject=ExportRestrictions\\_IndustrialRawMaterials](http://qdd.oecd.org/table.aspx?Subject=ExportRestrictions_IndustrialRawMaterials) [Accessed September 2019]

Roskill (2011). Gallium: Global Industry Markets and Outlook, 8th Edition. Roskill Information Services Ltd., London, UK.

Rudnick, R.L. and Gao. S. (2003). Composition of the Continental Crust. In: *Treatise on Geochemistry, Volume 3*. Editor: Roberta L. Rudnick. Executive Editors: Heinrich D. Holland and Karl K. Turekian. pp. 659. ISBN 0-08-043751-6. Elsevier, p.1-64.

Schulte, R. F.; Foley, N. K. (2014). Compilation of Gallium Resource Data for Bauxite Deposits: U.S. Geological Survey Open-File Report 2013-1272; [online] Available at: <http://pubs.usgs.gov/of/2013/1272/>

SCRREEN workshop. (2019). Validation Workshop on Critical Raw Materials, 10-12 September 2019, Thon Hotel Brussels City Centre. Stoiber, R.E. (1940). Minor elements in sphalerite. *Economic Geology* 1 June 1940, 35 (4), 501–519.

UNEP (2011). Recycling Rates of Metals. A Status Report, A Report of the Working Group on the Global Metal Flows to the International Resource Panel; United Nations Environment Programme, [online] Available at: <http://web.unep.org/publications/>

UNEP (2013). Metal Recycling - Opportunities, limits, infrastructure. A Report of the Working Group on the Global Metal Flows to the International Resource Panel. [online] Available at: <http://web.unep.org/publications/>

USGS. (2015). Gallium - Mineral Commodity Summaries. United States Geological Survey. Ed., Washington DC, pp.2

USGS. (2016). Gallium - Mineral Commodity Summaries. United States Geological Survey. Ed., Washington DC, pp.2 Available at: <https://s3-us-west-2.amazonaws.com/prd-wret/assets/palladium/production/mineral-pubs/gallium/mcs-2016-galli.pdf>

USGS. (2018). Gallium - Mineral Commodity Summaries. United States Geological Survey. Ed., Washington DC, pp.2 Available at: <https://s3-us-west-2.amazonaws.com/prd-wret/assets/palladium/production/mineral-pubs/gallium/mcs-2018-galli.pdf>

USGS. (2019). Gallium - Mineral Commodity Summaries. United States Geological Survey. Ed., Washington DC, pp.2 Available at: <https://prd-wret.s3-us-west-2.amazonaws.com/assets/palladium/production/s3fs-public/atoms/files/mcs-2019-galli.pdf>

USGS. (2018). Gallium - Mineral Commodity Summaries. United States Geological Survey. Ed., Washington DC, pp.2 Available at: <https://s3-us-west-2.amazonaws.com/prd-wret/assets/palladium/production/mineral-pubs/gallium/mcs-2018-galli.pdf> Weeks, R.A. (1989). Gallium, Germanium and Indium Resources. In: Carr, D.D. and Herz, N. (eds.) Concise Encyclopedia of Mineral Resources, Pergamon Press, Oxford, UK. pp. 133.

Weimar, A. (2011). High brightness LEDs: Manufacturing and applications. International Conference on Compound Semiconductor Manufacturing Technology, CS ManTech: Indian Wells, California, 2011.

World Mining Data (2019). Bundesministerium für Nachhaltigkeit und Tourismus. Austrian Federal Ministry of Sustainability and Tourism. [online] Available at: [www.en.bmwf.gv.at/Energy/WorldMiningData/Seiten/default.aspx](http://www.en.bmwf.gv.at/Energy/WorldMiningData/Seiten/default.aspx)

## **10.7.2 Data sources used in the criticality assessment**

Bio Intelligence Service (2015). Study on Data for a Raw Material System Analysis: Roadmap and Test of the Fully Operational MSA for Raw Materials – Final Report. Prepared for the European Commission, DG GROW

Communication with Mr. Istvan Fekete (CEO of bauxite mine in Eoszen Ltd), 2019.

Cui, R., Guo, J., Yin, L., Huy, D., Liedtke, M. (2016). Supply and Demand of Lithium and Gallium. P. 28 – 50. ISBN 978-3-943566-33-8. Bundesanstalt für Geowissenschaften und Rohstoffe - BGR, Hannover, Germany.

Eurostat (2019)a. International Trade Easy Comext Database [online] Available at: <http://epp.eurostat.ec.europa.eu/newxtweb/>

European Commission (2017). Report on Critical Raw Materials for the EU. Critical Raw Materials Profiles [online] Available at: [https://ec.europa.eu/growth/sectors/raw-materials/specific-interest/critical\\_en](https://ec.europa.eu/growth/sectors/raw-materials/specific-interest/critical_en)

European Commission (2016). DG Trade. Agreements [online] Available at: <http://ec.europa.eu/trade/policy/countries-and-regions/agreements/>

European Commission (2014)a. Report on Critical Raw Materials for the EU. Critical Raw Materials Profiles [online] Available at: [https://ec.europa.eu/growth/sectors/raw-materials/specific-interest/critical\\_en](https://ec.europa.eu/growth/sectors/raw-materials/specific-interest/critical_en)

Gunn, Gus (2014). Critical Metals Handbook. John Wiley & Sons.

OECD (2019). Export restrictions on Industrial Raw Materials. [online] Available at: [http://qdd.oecd.org/table.aspx?Subject=ExportRestrictions\\_IndustrialRawMaterials](http://qdd.oecd.org/table.aspx?Subject=ExportRestrictions_IndustrialRawMaterials) [Accessed September 2019]

OLED-Info (expert group) - OLED lighting introduction and market status <https://www.oled-info.com/oled-lighting>

Pavel, Claudiu C, Alain Marmier, Evangelos Tzimas, Tobias Schleicher, Doris Schüler, Matthias Buchert, and Darina Blagoeva (2016). "Critical Raw Materials in Lighting Applications: Substitution Opportunities and Implication on Their Demand." *Physica Status Solidi (A)* 213 (11): 2937–46.

SCRREEN workshop. (2019). Validation Workshop on Critical Raw Materials, 10-12 September 2019, Thon Hotel Brussels City Centre.

Tercero Espinoza, L., Hummen, T., Brunot, A., Hovestad, A., Pena Garay, I., Velte, D., Smuk, L., Todorovic, J., van der Eijk, C. and Joce, C. 2013. "Critical Raw Materials Substitution Profiles. September 2013 Revised May 2015. CRM\_InnoNet Available At:" <http://www.criticalrawmaterials.eu/wp-content/uploads/D3.3-Raw-Materials-Profiles-final-submitted-document.pdf>.

USGS. (2019). Gallium - Mineral Commodity Summaries. United States Geological Survey. Ed., Washington DC, pp.2 Available at: <https://prd-wret.s3-us-west-2.amazonaws.com/assets/palladium/production/s3fs-public/atoms/files/mcs-2019-galli.pdf>

World Mining Data (2019). Bundesministerium für Nachhaltigkeit und Tourismus. Austrian Federal Ministry of Sustainability and Tourism. [online] Available at: [www.en.bmwf.gv.at/Energy/WorldMiningData/Seiten/default.aspx](http://www.en.bmwf.gv.at/Energy/WorldMiningData/Seiten/default.aspx)

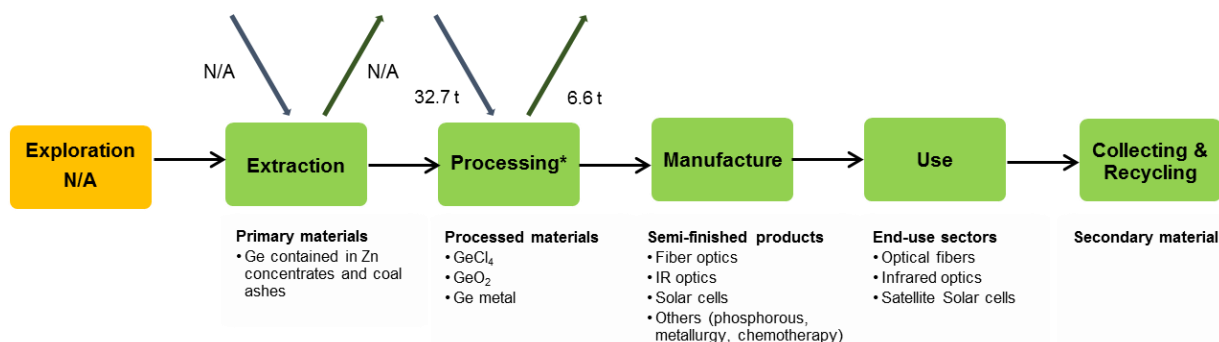
## **10.8 Acknowledgments**

---

This factsheet was prepared by the JRC. The authors would like to thank the Ad Hoc Working Group on Critical Raw Materials, as well as experts participating in SCRREEN workshops for their valuable contribution and feedback.

# 11 GERMANIUM

## 11.1 Overview

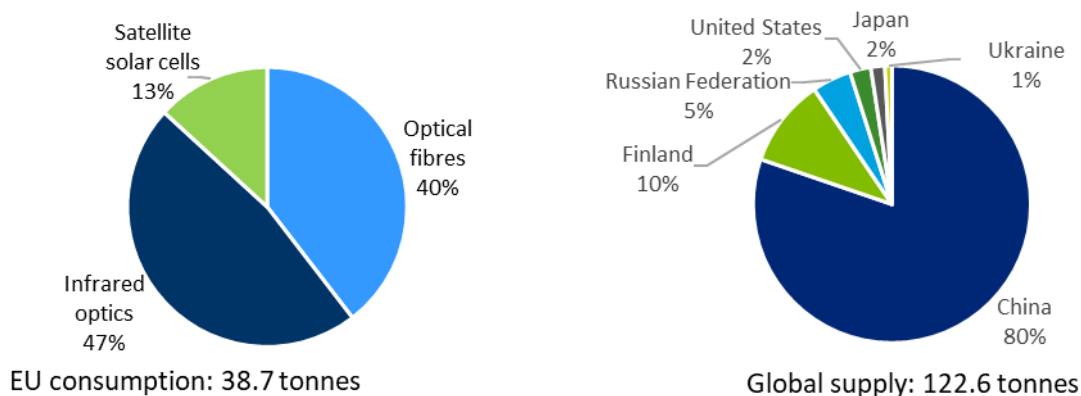


**Figure 139: Simplified value chain for germanium<sup>99</sup> for the EU, averaged over 2012-2016**

Germanium is a chemical element with symbol Ge and atomic number 32. It is a lustrous, hard, brittle, crystalline and greyish-white metalloid in the carbon group, chemically similar to its group neighbours tin and silicon. It resembles a metal; however, it also displays non-metal characteristics, such as semi conductivity. Purified germanium is a semiconductor, with an appearance most similar to elemental silicon. Like silicon, germanium naturally reacts and forms complexes with oxygen in nature. Unlike silicon, it is too reactive to be found naturally on Earth in the free (native) state. Germanium was on the list of CRMs in 2011, 2014 and 2017.

The criticality of germanium is assessed at processing stage. The trade codes considered in this factsheet are the following (Eurostat Comext, 2019):

- Unwrought germanium and germanium powders (trade code CN8 81129295),
- Germanium oxides (GeO<sub>2</sub>)(Trade code CN8 28256010),
- Germanium tetrachloride (GeCl<sub>4</sub>) (no trade code)



<sup>99</sup> The import figure at processing stage in the EU is the sum of germanium metal, GeCl<sub>4</sub>, and GeO<sub>2</sub>. The quantity of EU import of GeCl<sub>4</sub>, and GeO<sub>2</sub> was based on the figures in Critical Raw Materials Assessment 2017 since no new data was available. The export figure in green arrow at processing stage refers to the EU export of germanium metal, reported in Eurostat-Comext database.

**Figure 140: End uses (SCREEN, 2019) with estimated quantity of EU consumption and global supply of germanium<sup>100</sup>, (average 2012-2016)**

Due to the lack of reliable and up-to-date figures on EU import of all germanium products, the EU import and EU consumption figures reported in this factsheet are based on estimation. Consequently, the supply risk of germanium in this assessment is based on the global supply.

The world market traded about 150 tonnes of germanium in 2018, and it is expected to rise to a minimum of 165 tonnes by 2020 only with glassfibre applications at a rate of 3.5% per year (Fraunhofer ISI, 2018). The majority of germanium is traded on annual contracts and only small amounts are sold on the open market. The price of germanium dioxide (GeO<sub>2</sub>) was USD 1100 per kilogram in 2018, one and a half times higher than the price in 2017. Similar to prices of GeO<sub>2</sub>, the price of germanium metal in 2018 was at USD 1300 per kilogram, an increase of 20% in comparison to 2017's price (USGS, 2017b).

The EU imported germanium in the form of germanium metal, germanium dioxides, and germanium tetrachloride. The import figure was only available for germanium metal. The annual EU consumption of germanium over the period 2012-2016 was roughly estimated at 38.7 tonnes per year, considering the EU import of germanium dioxides and germanium tetrachloride in 2010-2014. China, United Kingdom, Russia, and United States were the main providers of germanium while the EU domestic production of germanium took place in Finland.

Germanium is used in several applications such as optical fibres, IR optics, wafers for satellites solar cells, IT applications, PET catalyst etc. Some of these end-uses, such as PET catalysts and IT applications, are not occurring in the EU (SCREEN, 2019).

Various alternatives are available for the substitution of germanium in some its applications (mainly the IT applications and catalysts applications, not relevant for the EU scope). However, many of these substitutes result in a loss of performance.

Germanium is an emerging substrates used for photovoltaic solar cells in satellite applications with higher efficiency than with silicon. Germanium may contribute to achieving the objectives of the "European strategic long-term vision for a prosperous, modern, competitive and climate neutral economy"<sup>101</sup>. Under this strategy, the transition to clean and renewable electricity is expected to decarbonize also other sectors such as heating, transport and industry.

The available resources of germanium are associated with certain zinc and lead-zinc-copper sulfide ores as well as coal ashes (USGS, 2019). Around half of total known resources are located in Russia (17,500 tonnes, all from coal ashes) and one quarter is located in China (10,860 tonnes, including 4,200 tonnes in zinc ores and slag, the remaining in coal ashes) (Melcher, F. and Buchholz, P., 2012). In the EU, resources of germanium are known to exist in Czechia, France, and Austria (Melcher, F. and Buchholz, P., 2013).

World known reserves for germanium are estimated at 8,600 tonnes in 2012 (Bio Intelligence Service, 2015), including 3,500 tonnes of proven reserves of germanium in China (European Commission, 2014). There are no reserves of germanium in the EU

---

<sup>100</sup> EU consumption is estimated and includes germanium oxides and germanium tetrachloride, based on the quantity of EU import for both products reported in criticality assessment 2017

<sup>101</sup> COM(2018) 773 final A Clean Planet for all. A European strategic long-term vision for a prosperous, modern, competitive and climate neutral economy

because historic European deposits (St Salvy, Bor, Bleiberg, Freiberg, Sardinia) are drained (Bio Intelligence Service, 2015).

According to the data reported by World Mining Data (2019), the world average production of refined germanium from the year 2012 to 2016 was 122 tonnes per year. China was the major producer with 80% of share of global production, followed by Russian Federation (5% of share), United States and Japan (2% of global supply each), and minor production from Ukraine (1% of global supply). The EU production of germanium was 12.6 tonnes, located in Finland. However, the production in Finland stopped in 2015.

USGS (2019) estimated that around 30% of global germanium production is supplied by recycling, mostly from scrap generated during the manufacture of fibre-optic cables and infrared optics. Due to the value of refined germanium, this scrap is reclaimed and fed back into the production process at a rate of 60%. There are two large global recyclers and refiners of zinc with combined germanium production in the EU (Melcher, F. and Buchholz, P., 2013).

Germanium is a non-toxic element, except for a few compounds. Germanium in the ppm range, when dissolved in drinking water may cause chronic disease.

China, one of the EU suppliers for germanium applied a 5% export tax on germanium oxide throughout 2012-2016 (OECD, 2019). No trade agreements existed between China and the EU regarding germanium trade (European Commission, 2019).

## **11.2 Market analysis, trade and prices**

---

### **11.2.1 Global market analysis and outlook**

Over the five years period from 2012 to 2016, China was the leading global producer of germanium metal and germanium compounds. China recovered germanium from germanium-bearing coal fly ash and zinc ore (USGS, 2016). Several events that took place in China have contributed to the change in price of germanium during this period, such as the application of export tax on germanium dioxide, the closure of a Chinese germanium dioxide plant owing to environmental concerns, stockpiling activities, and the collapse of FANYA metal exchange (USGS, 2016, 2017a, 2019).

Primary germanium was also recovered from zinc residues in Belgium and Canada (concentrates shipped from the United States), zinc residues in Finland, and coal ash in Russia (USGS, 2016).

Germanium supply depends largely on future demand of germanium and its price. As a by-product, germanium production is heavily dependent on zinc production and production from coal ashes. Since the market for germanium is small, it tends to be highly volatile. A higher price may result in increased interest shown by zinc refineries. According to experts, today's supply situation, which largely depends on China, is not a resource depletion issue, but the result of commercial terms (Umicore, 2019).

The future supply for germanium will most likely be driven by its largest emerging end-market: fibre optics (Fraunhofer ISI, 2018). The demand for germanium in fiber optic cables was 56 tonnes (39% of the quantity of refinery production in 2013). The future demand for germanium for this application is estimated to grow to 118 tonnes in 2035, reaching 81% of refinery production capacity in 2013 (Fraunhofer ISI, 2018).

**Table 59: Qualitative forecast of supply and demand of germanium (European Commission, 2017)**

Materials	Criticality of the material in 2020		Demand forecast			Supply forecast		
	Yes	No	5 years	10 years	20 years	5 years	10 years	20 years
Germanium	x		+	+	?	+	+	?

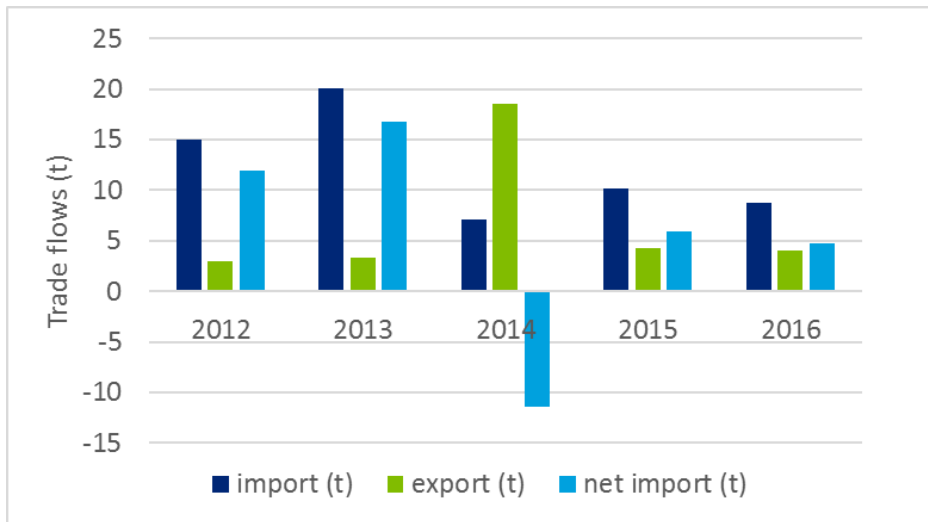
### 11.2.2EU trade

Over the period 2012-2016, the EU was a net importer of germanium metal (unwrought and powders), corresponding to 12.2 tonnes per year of germanium contained (Eurostat, 2019a). The EU export of germanium metal was reported at 6.6 tonnes per year, half of the EU import. According to the information reported in Eurostat, France, Germany, Belgium, and Latvia are among the EU exporters of germanium metal.

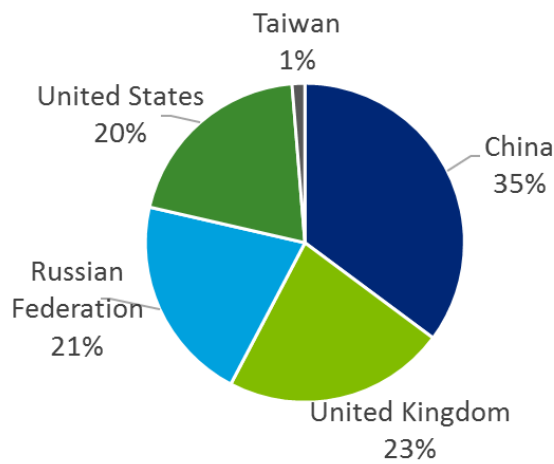
The EU also imported germanium in the form of germanium dioxides, and germanium tetrachloride. However, the data on EU trade of germanium dioxide and germanium tetrachloride were not available in Eurostat Comext database. In 2015, the annual EU import of germanium dioxide and germanium tetrachloride was estimated at 15.3 tonnes and 5.1 tonnes subsequently (Bio Intelligence Service, 2015).

Between 2012 and 2014, some crude germanium dioxide (GeO<sub>2</sub>) was produced in Finland from cobalt concentrates (mined in Congo by the owner of the Finnish refinery) (Bio Intelligence Service, 2015). The crude GeO<sub>2</sub> produced in Finland was used in the EU to produce germanium processed materials (GeO<sub>2</sub>, GeCl<sub>4</sub> and Ge metal), with most of them (80%) being exported outside the EU. The EU net production of refined germanium was only 2.5 tonnes of germanium contained, whereas it imported 36.7 tonnes.

China, one of the EU suppliers for germanium applied a 5% export tax on germanium oxide throughout 2012-2016 (OECD, 2019). The export tax was first introduced in 2010, since the Chinese Government attempted to limit exports of raw materials (European Commission, 2014). In order to protect germanium resources, China has taken multiple measures in recent years, including stockpiling and increase in tariffs, which resulted in significant decline in export of germanium and products thereof (European Commission, 2017). At the same time, China encouraged the export of more processed products through export tax rebates on products such as germanium ingots and optical lenses (European Commission, 2014). Other than China, Russia imposed a tax on the export of germanium waste and scrap (6.5%).



**Figure 141: EU trade flows for unwrought germanium metal (Eurostat, 2019a)**



EU imports: 32.7 tonnes

**Figure 142: EU imports of unwrought germanium, 2012-2016 (Eurostat, 2019a)**

### 11.2.3 Prices and price volatility

Figure 143 presents the price trend of germanium metal and germanium oxides ( $\text{GeO}_2$ ) from 2008-2018. The prices of germanium in 2009 and 2010 were low, following the global economic crisis in 2008. Later, the prices increased in 2012. This increase was believed to be related events that took place in China's supply: the closing of three Chinese germanium dioxide plants, the adoption of an export tax on germanium dioxide, and a limited supply available due to an amount reserved for a consumer specialised in solar and hydro projects (European Commission, 2014). Prices from 2012 to mid 2015 remained high also due to a combination of strategic government stockpiling of germanium metal and a speculative investors' demand organized by a Chinese minor metals trading platform, Fanya Metal Exchange (FME) (Industrial player, 2016).. The huge speculative demand by financial investors drove prices of minor metals such as indium, germanium, and bismuth to unprecedented levels in 2013-2014 (European Commission, 2017). On the



other hand, high price in 2012 incited processors to increase collection and recycling of new scrap (Bio Intelligence Service, 2015)

After the collapse of Fanya trading platform in first half of 2015, prices significantly dropped. According to the USGS (2017b), the germanium dioxide ( $\text{GeO}_2$ ) prices have decreased from USD 1,247 per kilogram (2011-2015 average) to only USD 830 per kilogram in 2016. In 2017, the price was even lower at USD 731 per kilogram.

The average prices of germanium metal over the period 2011-2014 reached the highest at USD 1,918 per kilogram in 2014. Similar to prices of  $\text{GeO}_2$ , the price of germanium metal was even lower in 2017 at USD 1,082 per kilogram following the collapse of FME.

However, starting from 2017, the price of  $\text{GeO}_2$  and germanium metal gradually increased. The price increases were associated to the recovery in the germanium market following a period of low prices in 2016 after the collapse of FME in 2015.

The price of germanium metal reached USD 1,300 per kilogram and USD 1,100 per kilogram for  $\text{GeO}_2$  in 2018. According to the USGS (2019), the increase in the price of germanium in 2018 were closely related to two main events: the partial force majeure at a refinery in Canada, and the implementation of stricter environmental standards in China.

The FME held several minor metal stocks including 92 tonnes of germanium before it collapsed. In early 2019, the government of China decided to put the stocks of these minor metals on auction (Argusmedia, 2019). There were concerns that a sudden release of stocks could cause prices to collapse.



**Figure 143: Germanium historical price volatility (USD/kg). Figures for 2008-2018 (USGS, 2017b)**

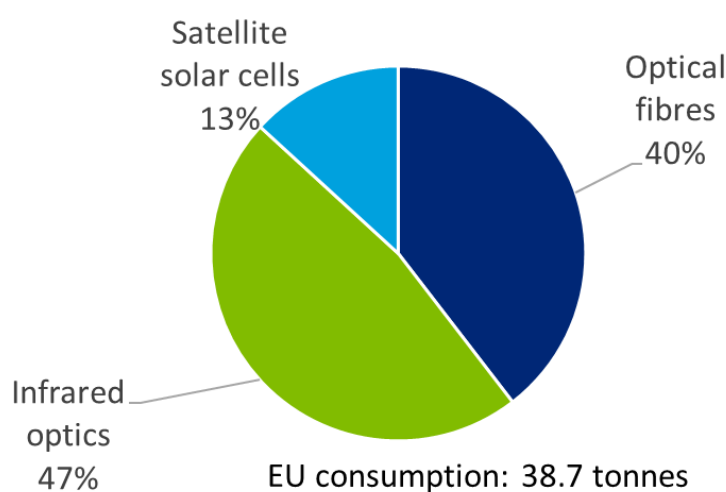
## 11.3 EU demand

### 11.3.1 EU demand and consumption

By taking into account the annual EU import of germanium unwrought (2012-2016), germanium dioxide and germanium tetrachloride (2010-2014), EU domestic production and EU exports, the EU apparent consumption of germanium processed materials is estimated at 38.7 tonnes per year over the period 2012-2016. The estimated quantity was approximately 29% of the world consumption in 2012-2016. Germanium entered in the EU is destined to the manufacture of germanium end-products.

### 11.3.2 Uses and end-uses of germanium in the EU

According to Asian Metals, the global use of germanium in 2016 are the following: fibre optics 24%, infrared optic 23 %, polymer catalysts 31 %, solar cells 12 %, others 10 % (Buchholz, 2019).



**Figure 144: EU end uses of germanium (SCREEN, 2019). Average figures for 2012-2016. (Eurostat 2019a)**

The three major global uses of germanium are in fibre optics, infrared optics and polymerisation catalysts for PET plastics. Use in electronic applications and satellite solar cells also play an important role at the global scale. The other applications are mainly for phosphors, metallurgy, and chemotherapy. However, it must be noted that in the EU, Germanium is not used as PET polymerisation catalysts as well as in the electronic industry.

Figure 144 presents the main uses of germanium in the EU.

- Fibre-optics (40% of share): Germanium oxide is used as a dopant in within the core of optical fibre. Small quantities of this compound are added to the pure silica glass to increase its refractive index; this prevents light absorption and signal loss. This type of fibre is used for high-speed telecommunication. Over the past years there has been substantial growth in this sector with increasing demand for more bandwidth.
- Infrared optics (47% of share): Germanium is transparent to infrared radiation (IR) wavelengths, both as a metal and in its oxide glass form. For this reason it is used to make lenses and windows for IR radiation. These are mainly used in military applications such as night-vision devices. Uses outside of the military are in advanced firefighting equipment, satellite imagery sensors and medical diagnostics.

- Solar cells (13% of end use share): Germanium-based solar cells are principally used in space-based applications but also in terrestrial installations. Demand for satellites has increased steadily from 2007 due to commercial, military, and scientific applications. The advantage of germanium substrates over the more common silicon based solar cells are the smaller size and weight and higher efficiency (over 25%). These solar cells are not common in terrestrial applications because of the cost of their manufacture. However these are considerably more efficient at converting solar energy into electricity, so fewer cells are required in a panel to produce equivalent amounts of power. It is thought that germanium-based cells will compete for a portion of the terrestrial market in the future.
- Other uses in the EU include gamma-ray detectors and organic chemistry, phosphors, metallurgy, and chemotherapy.

Germanium is also used in the following applications outside the EU:

- Polymerisation catalysts: Germanium dioxide is used outside the EU (and particularly in Japan) as a catalyst in the production of PET for plastic bottles, sheet, film and synthetic textile fibres. There is a drive to move towards different catalysts given the increasing price of germanium.
- Electronic components: Germanium is used as a semiconductor in several electronic applications. Some examples are high brightness Light Emitting Diodes (LEDs) in devices such as cameras and smartphone display screens. Silicon germanium transistors have been replacing other silicon based components in high speed wireless telecommunications devices due to the higher switching speeds and energy efficiency.

Relevant industry sectors in the EU are described using the NACE sector codes (Eurostat, 2019b, presented in Table 60.

**Table 60: germanium applications, 2-digit and associated 4-digit NACE sectors, and value added per sector (Eurostat, 2019b)**

<b>Applications</b>	<b>2-digit NACE sector</b>	<b>4-digit CPA</b>	<b>Value added of NACE 2 sector (M€)</b>
Optical fibres	C27 - Manufacture of electrical equipment	C2630- Manufacture of communication equipment; C2731 - Manufacture of fibre optic cables	80,745
Infrared optics	C26 - Manufacture of computer, electronic and optical products	C2670- Manufacture of optical instruments and photographic equipment	65,703
Satellite solar cells	C26 - Manufacture of computer, electronic and optical products	C2611- Manufacture of electronic components	65,703

### 11.3.3 Substitution

Many of the substitutes for germanium result in a loss of performance and are therefore not optimal. Research on efficient germanium substitutes is currently under progress (Industrial player, 2016).

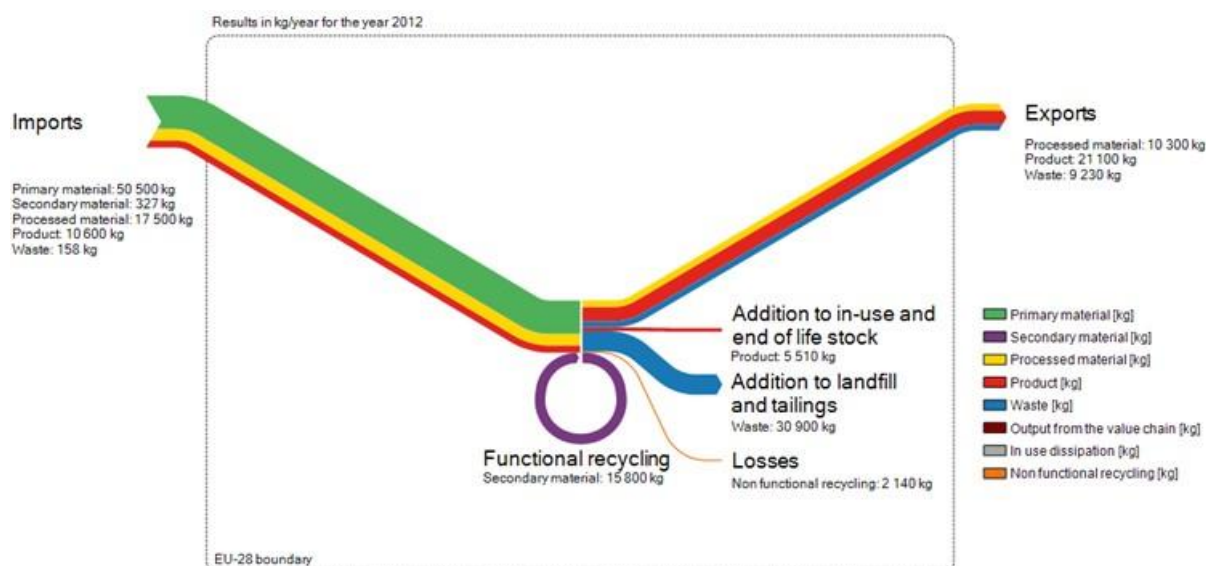
- Zinc selenide and zinc sulphide can be used as substitutes of germanium in infrared optics, but with a reduced performance (Industrial player, 2016). Tellurium is also a (partial) substitute in chalcogenide glasses for infrared optics (Industrial player, 2016).
- Substitutes of germanium in optical fibres are not really used because of performance losses, but fluorine and phosphorus can be mentioned, with a low probability of industrial use (Industrial player, 2016).
- There is actually no substitute for germanium in satellite solar cells, even if some research are ongoing on semiconductor materials based on gallium and indium such as InGaP, AlGaInP, InGaAsP, InGaAs (Industrial player, 2016).
- Silicon can be a less-expensive substitute for germanium in some electronic applications such as transistors (USGS, 2016). However, there has recently been a shift back to the use of germanium, albeit in materials with silicon, as this will allow the miniaturization of electronics (USGS, 2016). Some metallic compounds can be substituted in high-frequency electronics applications and in some light-emitting-diode applications (USGS, 2016). Antimony and titanium are substitutes for use as polymerization catalysts (USGS, 2016).

## 11.4 Supply

---

### 11.4.1 EU supply chain

- Extraction stage  
Resources of germanium are known to exist in the EU. In the past, there was a production of germanium in France and Austria. However, there are no known reserves of germanium in the EU. In 2012-2016, there was no germanium concentrates recovered neither from a European mine in activity, nor from coal ashes in the EU.
- Processing stage  
World Mining Data reported that the production of germanium in Finland over the period of 2012-2016 was 12.6 tonnes per year (World Mining Data, 2019). From 2012 to 2014, Finland produced some crude germanium dioxide ( $\text{GeO}_2$ ) from cobalt concentrates (mined in Congo by the owner of the Finnish refinery) with 80% of the final processed materials ( $\text{GeO}_2$ ,  $\text{GeCl}_4$  and Ge metal) exported outside the EU (Bio Intelligence Service, 2015). The Finnish plant stopped the production of germanium in 2015 (Bio Intelligence Service, 2015). There were some very rich germanium mines in France and Austria but they all closed in the 1990's once empty (Bio Intelligence Service, 2015).
- Manufacturing stage  
The EU consumption of Ge processed materials are destined to the manufacturing of germanium processed products in the EU.
- Recycling stage  
Recyclex in France with its subsidiary PPM Pure Metals GmbH (Germany) and Umicore in Belgium are large global recyclers and refiners of zinc, both with combined germanium production. (Melcher, F. and Buchholz, P., 2013).



**Figure 145: Simplified diagram of germanium material system analysis for 2012 (Bio Intelligence Service, 2015)**

### 11.4.2 Supply from primary materials

Germanium recovered from the leaching of zinc residues or coal fly ash and is precipitated into germanium concentrates and crude germanium dioxide ( $\text{GeO}_2$ ). Crude  $\text{GeO}_2$  is then converted into germanium tetrachloride ( $\text{GeCl}_4$ ) and hydrolysed to produce high grade  $\text{GeO}_2$ .  $\text{GeCl}_4$  is also partly used to produce high grade  $\text{GeO}_2$ . A fraction of high grade  $\text{GeO}_2$  is then reduced and refined into germanium metal (Bio Intelligence Service, 2015).

Today, germanium is extracted as a by-product of zinc production and from coal fly ash. It is estimated that 60% of worldwide production of germanium is sourced from zinc ores, mainly the zinc sulphide mineral sphalerite, and 40% from coal. China and Russia are the only countries to recover germanium from coal fly ash.

#### 11.4.2.1 Geology, resources and reserves of germanium

**Geological occurrence:** Germanium is a rare metal, with an average concentration in the Earth's crust of 1.6-2 ppm, and 1.4 ppm in the upper crust (Rudnick, 2003).

As is the case for many minor metals, germanium does not occur in its elemental state in nature, but is found as a trace metal in a variety of minerals and ores. Only a few minerals of germanium have been identified, the major one being germanite ( $\text{Cu}_{13}\text{Fe}_2\text{Ge}_2\text{S}_{16}$ ). This was the principal source of germanium in the past. However, no ore bodies with commercially viable contents of germanite are known at present.

#### Global resources and reserves<sup>102</sup>:

<sup>102</sup> There is no single source of comprehensive evaluations for resources and reserves that apply the same criteria to deposits of germanium in different geographic areas of the EU or globally (comment: see Melcher and Buchholz, 2014, probably most comprehensive overview; the resource numbers in that paper are still valid). The USGS collects information about the quantity and quality of mineral resources but does not directly measure reserves, and companies or governments do not directly report reserves to the USGS. Individual companies may publish regular mineral resource and reserve reports, but reporting is done using a variety of systems of reporting depending on the location of their operation, their corporate identity and stock market requirements. Translations between national reporting codes are possible by application of the CRIRSCO template.<sup>102</sup>, which is also consistent with the United Nations Framework Classification (UNFC) system. However, reserve and resource

Global resources and reserve data for germanium are difficult to obtain, because details related to trace-metal concentrations in many sulphide and coal deposits are not readily available, or are of poor quality (Melcher, F. and Buchholz, P.,2013). The available resources of germanium are associated with certain zinc and lead-zinc-copper sulfide ores (USGS, 2016a), as well as coal ashes. The amount of germanium potentially recoverable from coal ash is unlimited, but the commercial recovery is currently not viable except for germanium-rich coals from Russia and China (Melcher, F. and Buchholz, P.,2013).

Global known resources of germanium are estimated at 11,000 tonnes in zinc ores and 24,600 tonnes in coal in 2013 (European Commission, 2014). Approximately half of total known resources are located in Russia (17,500 tonnes, all from coal ashes) and one quarter is located in China (10,860 tonnes, including 4,200 tonnes in zinc ores and slag, the remaining in coal ashes) (European Commission, 2014). The USA and Congo also have significant resources of germanium in zinc ores (respectively 2,300 and 3,750 tonnes), while Canada, Mexico, Namibia, Ukraine and Uzbekistan account for the rest of germanium resources (European Commission, 2014).

World known reserves for germanium are estimated at 8,600 tonnes in 2012, including 3,500 tonnes of proven reserves of germanium in China (Bio Intelligence Service, 2015).

Another source estimated 13,000 tonnes of germanium reserves and resources from sulphide deposits and 25,000 tonnes from germanium-rich coal (Melcher, F. and Buchholz, P.,2013).

#### **EU resources and reserves <sup>103</sup>:**

Some resources of germanium in zinc mines exist in the EU but they are not quantified. They have been estimated at less than 1,000 tonnes using the low germanium content (0-10 ppm) in EU zinc resources (Bio Intelligence Service, 2015).

In the EU, high germanium concentrations were reported in Bleiberg, Austria (on average 300ppm; 126 tonnes germanium produced) and Cave del Predil, Italy (250-450 ppm) (Melcher, F. and Buchholz, P.,2013).

In the past, there were deposits of germanium in Noailhac-Saint Salvy, France, that contributed significantly to the global germanium production until its closure in 1993 (Melcher, F. and Buchholz, P.,2013). There were reportedly germanium-bearing deposits in Freiberg district, Germany, Sardinia (Italy), and Kirki (Greece), and Czechia, all of which with limited economic potential or known to be drained (Bio Intelligence Service, 2015). Minerals4EU (2019) reported an estimated quantity of 473 tonnes with 0.01% of germanium content in Czechia, categorized as potentially economic. To-date, there has not been any new information on Minerals4EU.

---

data are changing continuously as exploration and mining proceed and are thus influenced by market conditions and should be followed continuously.

<sup>103</sup> For Europe, there is no complete and harmonised dataset that presents total EU resource and reserve estimates for germanium. The Minerals4EU project is the only EU-level repository of some mineral resource and reserve data for germanium, but this information does not provide a complete picture for Europe. It includes estimates based on a variety of reporting codes used by different countries, and different types of non-comparable datasets (e.g. historic estimates, inferred reserves figures only, etc.). In addition, translations of Minerals4EU data by application of the CRIRSCO template is not always possible, meaning that not all resource and reserve data for germanium the national/regional level is consistent with the United Nations Framework Classification (UNFC) system (Minerals4EU 2019). Many documented resources in Europe are based on historic estimates and are of little current economic interest. Data for these may not always be presentable in accordance with the UNFC system. However a very solid estimation can be done by experts.

Polish Geological Institute (2017) reports an estimated resource of 30 tonnes of germanium in the Zawiercie deposit, according to the Polish classification. In Portugal, the Iberian Pyrite Belt, that has deposits such as Neves Corvo and Barrigão, is potential for germanium, which is present in the latter with average whole-rock contents of 61 ppm (Reiser et al. 2010). Until 2020, germanium is not recovered from these deposits. Germanium was also known to exist in some deposits in Romania and Slovenia, but no resource data is available.

There was no information on the reserves of germanium in the EU.

Some exploration activities were undertaken within the EU for germanium, in particular in Portugal and Slovakia according to the Minerals4EU (2019). At Bleiberg (Austria) exploration was carried out by Tacsá Resources, but the project was cancelled in January 2018.

#### **11.4.2.2 World and EU mine production**

As with data for reserves and resources, the data for global germanium mine production are not readily available or are of poor quality (Melcher, F. and Buchholz, P.,2013). In 2010, the global germanium production was estimated to be double the reported refined germanium (300 tonnes in residues), suggesting that major amounts of germanium were not being extracted from residues. There was only one zinc mine very rich in germanium (400 g/t) within the world (located in Tennessee, USA), but it has been closed temporarily in the last years (Bio Intelligence Service, 2015). Several zinc mines with medium germanium content (50-100 g/t) are located in Alaska, Mexico and Australia, and there are also plenty of zinc mines with low germanium content (0-10 ppm) located in China, Congo, India, Bolivia, etc. (Bio Intelligence Service, 2015).

Most of germanium is extracted from zinc ores as a by-product, mainly in China, the United States, Australia and India (Bio Intelligence Service, 2015). Only a small fraction of the germanium contained in the zinc ore extracted worldwide is effectively recovered and further used in the value chain of germanium. The main fraction is not valued and is considered as lost (in tailings, as impurities in zinc products, etc.). About 760 tonnes of Germanium were present in 2012 in zinc ores mined worldwide, but only a small proportion is effectively recovered.

#### **11.4.2.3 World refinery production**

The data for global germanium mine and refinery production are not readily available or are of poor quality. Germanium is produced as a by-product of zinc mining and also extracted from coal ash.

- As by-product of zinc mining: after mining, the germanium-containing ores are processed to increase their base metal and germanium contents using conventional mechanical and flotation methods (Melcher, F. and Buchholz, P.,2013).

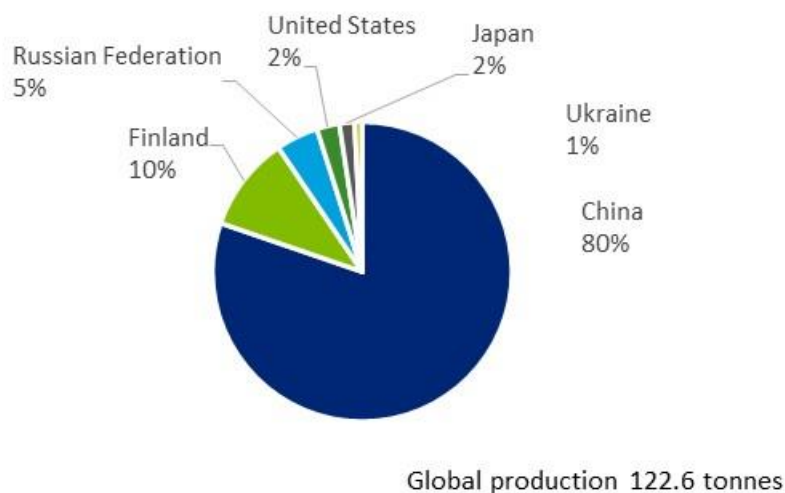
On a global scale, as little as 3% of the germanium contained in zinc concentrates is recovered. There are several reasons why such a low percentage of germanium is refined from zinc concentrates:

1. Germanium recovery can have a negative impact on zinc recovery, detracting from the core business for these refineries (European Commission, 2014). As a consequence, except the Chinese refineries, only two zinc refineries (located in the USA and Canada) reportedly in 2011 extract germanium as part of their operations.

2. High germanium zinc concentrates must be sourced in order to make recovery of germanium economic. This may increase the cost of sourcing the concentrate, making it prohibitive. This is of particular importance given that germanium production only accounts for a low percentage of the business's turnover. For example, in the Canadian zinc refinery, germanium accounts for at most 2% of total revenues. Therefore, the investment may not be profitable unless germanium prices are sufficiently high.
- Extraction from coal ash: High concentrations of germanium in coal ashes from coal and lignite deposits were first found in 1930 while the process to recover it was first developed and used between 1950 and 1974, both took place in the UK (Melcher, F. and Buchholz, P.,2013). Approximately 30-50% of primary germanium production is from lignite deposits in China, Russia, and Uzbekistan. The recovery of germanium from coal includes burning the coal at 1200°C, filtering the ashes, pyrometallurgical treatment, followed by sulfuric acid leaching (Melcher, F. and Buchholz, P.,2013). Significant amounts of germanium are contained in ash and flue dust generated in the combustion of certain coals for power generation (USGS, 2019). The amount of germanium potentially recoverable from coal ash is unlimited, but the commercial recovery is currently not viable except for germanium-rich coals from Russia and China (Melcher, F. and Buchholz, P.,2013).

Figure 146 presents the average share of world refinery production of germanium over the period 2012-2016 (WMD, 2019). China was the largest producer of refined germanium, accounting for 80% of global supply. The EU refining activity of germanium from cobalt ores took place in Finland, until 2015 (Bio Intelligence Service, 2015).

In 2015, total production of refined germanium was estimated to be around 122.6 tonnes. This comprised germanium recovered from zinc concentrates, fly ash from burning coal, and recycled material.



**Figure 146: Global refinery production of germanium, 2012-2016. (World Mining Data, 2019)**

### 11.4.3 Supply from secondary materials/recycling

It is estimated that around 30% of global germanium production is supplied by recycling, mostly from scrap generated during the manufacture of fibre-optic cables and infrared optics (new scrap). Due to the value of refined germanium, this scrap is reclaimed and fed



back into the production process (European Commission, 2014). On the other hand, due to its high dispersion in most products and application in very low quantities, only a little quantity of germanium is recovered from post-consumer scrap (old scrap) (Melcher, F. and Buchholz, P.,2013).

#### **11.4.3.1 Industrial recycling (new scrap)**

As germanium products usually need to be of a very high purity, a lot of production scrap is generated all along the manufacturing chain. The high price of refined germanium encourages recycling. The majority of the new scrap generated during the manufacture of germanium processed materials and products is recycled by being fed back into the manufacturing process (Sundqvist Oeqvist, Pr. Lena et al. ,2018).

All the waste generated during the conversion of germanium dioxide ( $\text{GeO}_2$ ) and the production of germanium tetrachloride ( $\text{GeCl}_4$ ) and germanium metal is internally recycled (Bio Intelligence Service, 2015).

The manufacture of optical fibres generates about 75% of waste, and about 80% of this new scrap is reprocessed (Bio Intelligence Service, 2015). The effluents from optic fiber manufacturing process should be processed on site due to economic and environmental reasons (Ge recovery, chlorine gas disposal). The specialists from Bell Technologies invented and then implemented to industrial practice the effective method for germanium recovery from optic fiber production effluents, with Ge recovery rate over 95% (Sundqvist Oeqvist, Pr. Lena et al. ,2018).

The waste produced during the manufacture of Infra Red optics amounts about 30% of the germanium input, of which 100% is internally recycled. The sawing (from large high purity mono-crystals) and grinding of germanium wafers during wafer manufacturing produces a lot of production scrap (e.g. germanium dust from sawing the wafers) - almost 50% of the germanium input - which is fully recycled internally (Bio Intelligence Service, 2015). Downstream producers of solar cells or infrared optics also generate a lot of production scrap on the way to the final product. About 50% of waste from this process is recycled (Melcher, F. and Buchholz, P.,2013).

#### **11.4.3.2 Post-consumer recycling (old scrap)**

Due to its high dispersion in most products and application in very low quantities, only a little quantity of germanium is recovered from post-consumer scrap (old scrap) (Melcher, F. and Buchholz, P.,2013). Recycling of old scrap has increased over the past decade but is still low. The functional recycling rate has been estimated at about 12% (Bio Intelligence Service, 2015) and the end-of-life recycling input rate is assessed at 2% only. Very few used end-products are collected separately to be recycled: all used optical fibres go into non-functional recycling in C&D waste, solar cells for satellites are not recovered and only some germanium is recycled from old scrap of IR optics. According to experts, this situation will not improve in future due to dissipation and low grade uses, as well as extra-terrestrial applications (solar cells for satellites) that cannot be collected, etc. (Industrial player, 2016) Moreover, in most of the products and devices containing germanium the metal is present in trace amounts, making it technically and economically difficult to recover secondary germanium.

**Table 61: Material flows relevant to the EOL-RIR of germanium<sup>104</sup>, reference year 2012**

MSA Flow	Value (kg)		Year
B.1.1 Production of primary material as main product in EU sent to processing in EU	0		2012
B.1.2 Production of primary material as by product in EU sent to processing in EU	0		2012
C.1.3 Imports to EU of primary material	50,494		2012
C.1.4 Imports to EU of secondary material	327		2012
D.1.3 Imports to EU of processed material	17,472		2012
E.1.6 Products at end of life in EU collected for treatment	9,874		2012
F.1.1 Exports from EU of manufactured products at end-of-life	79		2012
F.1.2 Imports to EU of manufactured products at end-of-life	158		2012
G.1.1 Production of secondary material from post consumer functional recycling in EU sent to processing in EU	0		2012
G.1.2 Production of secondary material from post consumer functional recycling in EU sent to manufacture in EU	1,211		2012

## 11.5 Other considerations

### 11.5.1 Environmental and health and safety issues

Germanium is a non-toxic element, except for a few compounds. Germanium in the ppm range, when dissolved in drinking water may cause chronic disease (Melcher, F. and Buchholz, P., 2013).

With environmental regulations becoming more stringent, the ecological footprint of Ge recovery from coal starts to get more attention. An LCA study has demonstrated the ecological benefit of other sources, such as recycling or Ge from Zn-based ores (Robertz, Benedicte, Jensen Verhelle, and Maarten Schurmans, 2015)

### 11.6 Comparison with previous EU assessments

The assessment has been conducted using the same methodology as for the 2017 list. Supply risk was analysed at processing stage, the stage considered to be the bottleneck of the supply in the EU. Constructing a reliable estimation of EU consumption and EU supply risk of germanium was confronted by the lack of up-to-date and publicly available data for the EU for the trade of germanium products such as germanium oxides and germanium tetrachloride. Therefore, compared to the assessment of supply risk in 2017, only global supply of germanium was taken into consideration for the calculation of supply risk. The change of approach can be seen in the increase of supply risk of germanium, reflecting a high production concentration in China. The results of criticality assessment 2020 and of the earlier assessments are shown in Table 62.

**Table 62: Economic importance and supply risk results for germanium in the assessments of 2011, 2014, 2017, 2020 (European Commission, 2011; European Commission, 2014; European Commission, 2017)**

Assessment	2011		2014		2017		2020	
	EI	SR	EI	SR	EI	SR	EI	SR
Germanium	6.28	2.73	5.54	1.94	3.5	1.9	3.45	3.89

<sup>104</sup> EOL-RIR=(G.1.1+G.1.2)/(B.1.1+B.1.2+C.1.3+D.1.3+C.1.4+G.1.1+G.1.2)

The economic importance of germanium has slightly decreased between 2012 and 2016 while the end-use application sector remained the same in comparison to the results in 2017's criticality assessment. The change was caused by the change in the value added of the sectors.

## **11.7 Data sources**

---

In this assessment, the only information available on the trade of germanium was for unwrought germanium. The lack of publicly available data for the EU for the trade of germanium products such as germanium oxides and germanium tetrachloride was identified. Estimation for the EU import of germanium oxides and tetrachloride was taken from the "Study on Data for a Raw Material System Analysis: Roadmap and Test of the Fully Operational MSA for Raw Materials – Final Report", published in 2015.

### **11.7.1 Data sources used in the factsheet**

Argusmedia (2019). News – China to auction Fanya Ga, Ge, Se, Te stocks. [online] Available at: <https://www.argusmedia.com/en/news/1994012-china-to-auction-fanya-ga-ge-se-te-stocks> [Published date: 11 October 2019]

Bio Intelligence Service (2015). Study on Data for a Raw Material System Analysis: Roadmap and Test of the Fully Operational MSA for Raw Materials – Final Report. Prepared for the European Commission, DG GROW.

Buchholz, Peter. (2019). Consultation after Critical Raw Materials Validation Workshop in Brussels, September 2019.

Fraunhofer ISI (2016). DERA-Rohstoffinformationen Nr. 28, Rohstoffe für Zukunftstechnologien, 2016 [online] Available at: [https://www.deutsche-rohstoffagentur.de/DERA/DE/Downloads/Studie\\_Zukunftstechnologien-2016.pdf?\\_\\_blob=publicationFile&v=5](https://www.deutsche-rohstoffagentur.de/DERA/DE/Downloads/Studie_Zukunftstechnologien-2016.pdf?__blob=publicationFile&v=5)

European Commission (2011). Critical raw materials for the EU. [online] Available at: [https://ec.europa.eu/growth/sectors/raw-materials/specific-interest/critical\\_en](https://ec.europa.eu/growth/sectors/raw-materials/specific-interest/critical_en)

European Commission (2014) Report on critical raw materials for the EU - Critical raw materials profiles. Germanium profile, p67-76.

European Commission (2017). Critical raw materials factsheets 2017. [online] Available at: <https://publications.europa.eu/en/publication-detail/-/publication/7345e3e8-98fc-11e7-b92d-01aa75ed71a1/language-en>

European Commission (2019). Negotiations and Agreements - Trade [online] Available at: <http://ec.europa.eu/trade/policy/countries-and-regions/negotiations-and-agreements/>

Eurostat (2019)a. International Trade Easy Comext Database [online] Available at: <http://epp.eurostat.ec.europa.eu/newxtweb/>

Eurostat (2019)b. Annual detailed enterprise statistics for industry (NACE Rev. 2, B-E). [online] Available at: [http://ec.europa.eu/eurostat/en/web/products-datasets/-/SBS\\_NA\\_IND\\_R2](http://ec.europa.eu/eurostat/en/web/products-datasets/-/SBS_NA_IND_R2)

Industrial player (2016). Communication during the workshop held in Brussels on 28/10/2016

Melcher, Frank, and Peter Buchholz. (2012). Current and Future Germanium Availability from Primary Sources, 31.

Melcher, F. and Buchholz, P. (2013). Germanium. In Critical Metals Handbook, G. Gunn (Ed.). doi:10.1002/9781118755341.ch8

Minerals4EU (2019). European Minerals Yearbook. [online] Available at: [http://minerals4eu.brgm-rec.fr/m4eu-yearbook/theme\\_selection.html](http://minerals4eu.brgm-rec.fr/m4eu-yearbook/theme_selection.html)

OECD (2019). Export restrictions on Industrial Raw Materials. [online] Available at: [http://qdd.oecd.org/table.aspx?Subject=ExportRestrictions\\_IndustrialRawMaterials](http://qdd.oecd.org/table.aspx?Subject=ExportRestrictions_IndustrialRawMaterials) [Accessed September 2019]

Robertz, Benedicte, Jensen Verhelle, and Maarten Schurmans (2015). "The Primary and Secondary Production of Germanium: A Life-Cycle Assessment of Different Process Alternatives." JOM 67(2): 412–24.

Rudnick, R.L. and Gao. S. (2003). Composition of the Continental Crust. In: Treatise on Geochemistry, Volume 3. Editor: Roberta L. Rudnick. Executive Editors: Heinrich D. Holland and Karl K. Turekian. pp. 659. ISBN 0-08-043751-6. Elsevier, p.1-64

SCRREEN workshop. (2019). Validation Workshop on Critical Raw Materials, 10-12 September 2019, Thon Hotel Brussels City Centre.

Umicore (2019). Consultation after Critical Raw Materials Validation Workshop in Brussels, September 2019.

USGS (2016). Mineral Commodity Summaries: Germanium. [online] Available at: <https://s3-us-west-2.amazonaws.com/prd-wret/assets/palladium/production/mineral-pubs/germanium/mcs-2016-germa.pdf>

USGS (2017a). Mineral Commodity Summaries: Germanium. [online] Available at: <https://s3-us-west-2.amazonaws.com/prd-wret/assets/palladium/production/mineral-pubs/germanium/mcs-2017-germa.pdf>

USGS (2017). Mineral Year book – Data Release: Germanium. [online] Available at: <https://prd-wret.s3-us-west-2.amazonaws.com/assets/palladium/production/s3fs-public/atoms/files/myb1-2017-germa-adv.xlsx>

USGS (2019). Mineral Commodity Summaries: Germanium. [online] Available at: [https://prd-wret.s3-us-west-2.amazonaws.com/assets/palladium/production/s3fs-public/atoms/files/mcs-2019-germa\\_0.pdf](https://prd-wret.s3-us-west-2.amazonaws.com/assets/palladium/production/s3fs-public/atoms/files/mcs-2019-germa_0.pdf) [Accessed October 2019]

World Mining Data (2019). Bundesministerium für Nachhaltigkeit und Tourismus. Austrian Federal Ministry of Sustainability and Tourism. [online] Available at: [www.en.bmwfw.gv.at/Energy/WorldMiningData/Seiten/default.aspx](http://www.en.bmwfw.gv.at/Energy/WorldMiningData/Seiten/default.aspx)

## **11.7.2 Data sources used in the criticality assessment**

Bio Intelligence Service (2015). Study on Data for a Raw Material System Analysis: Roadmap and Test of the Fully Operational MSA for Raw Materials – Final Report. Prepared for the European Commission, DG GROW.

European Commission (2014) Report on critical raw materials for the EU - Critical raw materials profiles. Germanium profile, p67-76.

European Commission (2016). DG Trade. Agreements [online] Available at: <http://ec.europa.eu/trade/policy/countries-and-regions/agreements/>

European Commission (2017). Critical raw materials factsheets 2017. [online] Available at: <https://publications.europa.eu/en/publication-detail/-/publication/7345e3e8-98fc-11e7-b92d-01aa75ed71a1/language-en>

Eurostat (2019)a. International Trade Easy Comext Database [online] Available at: <http://epp.eurostat.ec.europa.eu/newxtweb/>

Nyrstar, at the CRM workshop 28/10 2016

OECD (2019). Export restrictions on Industrial Raw Materials. [online] Available at: [http://qdd.oecd.org/table.aspx?Subject=ExportRestrictions\\_IndustrialRawMaterials](http://qdd.oecd.org/table.aspx?Subject=ExportRestrictions_IndustrialRawMaterials) [Accessed September 2019]

SCRREEN workshop. (2019). Validation Workshop on Critical Raw Materials, 10-12 September 2019, Thon Hotel Brussels City Centre.

Tercero, L., Stotz, H., Otmar Deubzer, García, R. B., Lepe, G. R., Bilewska, K., ... Hu, X. (2018). SCRREEN D5.1 Critical Raw Material substitution profiles. In SCRREEN - D5.1. Retrieved from <http://screen.eu/wp-content/uploads/2018/05/SCRREEN-D5.1-CRM-profiles.pdf>

Umicore (2019). Consultation after Critical Raw Materials Validation Workshop in Brussels, September 2019.

USGS (2016). Mineral Commodity Summaries: Germanium. [online] Available at: <https://s3-us-west-2.amazonaws.com/prd-wret/assets/palladium/production/mineral-pubs/germanium/mcs-2016-germa.pdf>

World Mining Data (2019). Bundesministerium für Nachhaltigkeit und Tourismus. Austrian Federal Ministry of Sustainability and Tourism. [online] Available at: [www.en.bmwf.gv.at/Energy/WorldMiningData/Seiten/default.aspx](http://www.en.bmwf.gv.at/Energy/WorldMiningData/Seiten/default.aspx)

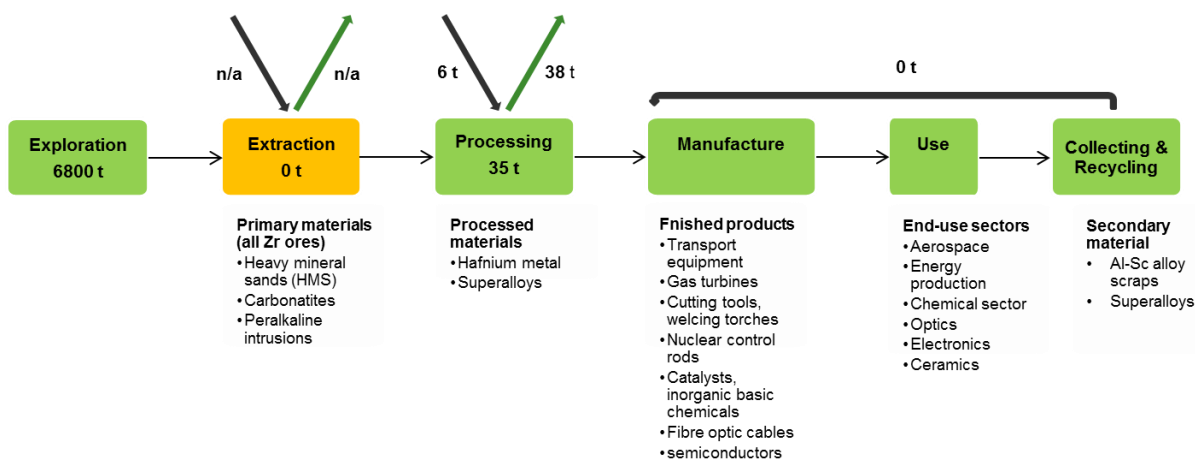
## **11.8 Acknowledgments**

---

This factsheet was prepared by the JRC. The authors would like to thank the Ad Hoc Working Group on Critical Raw Materials as well as experts participating in SCRREEN workshops for their valuable contribution and feedback, especially to Peter Buchholz from DERA.

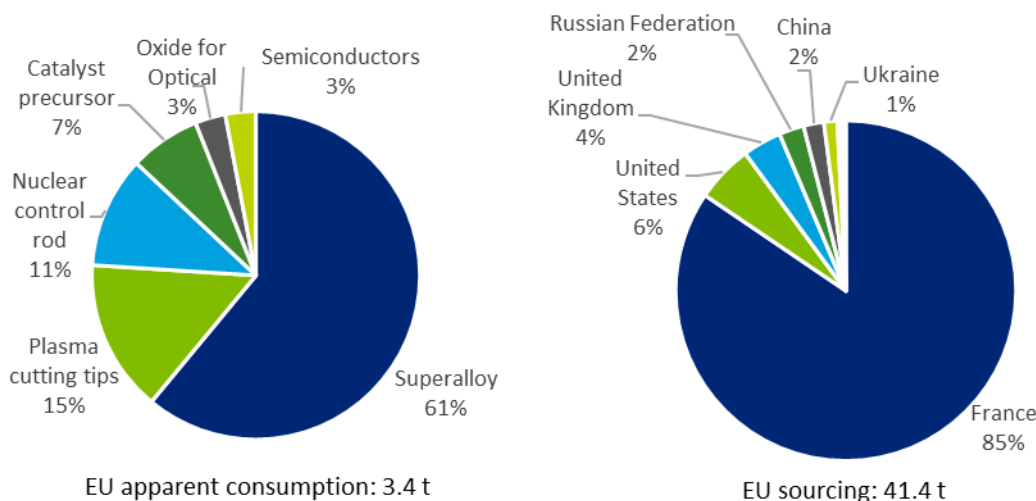
# 12 HAFNIUM

## 12.1 Overview



**Figure 147: Simplified value chain for hafnium for the EU, averaged over 2012-2016<sup>105</sup>, n/a: flow unknown.**

Hafnium is a chemical element with chemical symbol Hf and atomic number 72. It was discovered in 1923 and its name is derived from the Latin name for Copenhagen “Hafnia”. Hafnium is a hard, ductile metal similar to stainless steel in its appearance and chemically very similar to zirconium. For this reason, zirconium is discussed on several occasions in this factsheet. In nature, hafnium is always bound up with zirconium compounds, from which it needs to be extracted using advance metallurgical processing (ALKANE, 2017). Its main commercial sources are zircon and baddeleyite; these are available as by-products from the extraction of titanium minerals (Nielsen & Wilfing, 2010).



**Figure 148: End uses and EU sourcing of hafnium (processing stage) and EU sourcing, average 2012-2016.**

Commercial production of hafnium is driven by demand in the nuclear industry for high purity zirconium metal alloys (Moss *et al.*, 2011). Hafnium is used in high-temperature

<sup>105</sup> JRC elaboration on multiple sources (see next sections).

alloys and ceramics, since some of its compounds are very refractory: they will not melt except under the most extreme temperatures (Lenntech, 2016). Major uses of hafnium are located in the aerospace sector (super alloys) and the energy sector (gas turbines), and in the nuclear sector (nuclear reactor control rods).

For the purpose of this assessment, hafnium metal at processing stage is analysed (code CN 8112 92 10). The product group code covering hafnium metal is CN 8112 92 10, and labelled "unwrought hafnium "celtium"; hafnium powders; hafnium waste and scrap (excl. ash and residues containing hafnium)".

The hafnium market is strongly linked to the zirconium market, which shows a volume of US\$2,000-3,000 million. No such data is available for the hafnium market. Hafnium metal is not traded publicly, therefore worldwide price trends are not readily available.

The apparent EU consumption of hafnium metal was calculated as 3.4 tonnes per year (average 2012-2016). However, production data are vague and trade data are questionable.

According to the data available, global production is dominated by two countries: France and the United States. France is the world major producer of hafnium, with 35 tonnes per year (49% of global production). The United States follows with 31 tonnes (44%). The remainder is distributed across China, Russia and Ukraine. Due to this high production of France, the EU has no import reliance and at the same time is a major global hafnium exporter (mainly France and Germany, mainly to the US).

Supply of hafnium is heavily dependent on the nuclear industry and its demand for pure zirconium. This is because hafnium is recovered solely as by-product at the zirconium metal purification (high grade separation of zirconium and hafnium). This purified zirconium metal is demanded by the nuclear industry.

Following the Fukushima accident in 2011, several countries such as Germany, Belgium and Switzerland have reconsidered drastically their nuclear energy policies. However, most countries remain committed to their energy programs (Hayashi & Hughes, 2012), thus there are no fundamental concerns about future zirconium demand, and thus no worries about hafnium (co-)production.

The major applications for hafnium are the following:

- Super alloys: the major application for hafnium is as an alloy addition in polycrystalline nickel-based super alloys; for example, MAR-M 247 alloy contains 1.5% hafnium. These alloys are used in the aerospace industry both in turbine blades and vanes but also in industrial gas turbines. The super-alloy industry requires the purest form of hafnium, crystal bars, with low zirconium content. Demand and supply for this form of hafnium approximately equal, making the sector volatile.
- Nuclear control rods: hafnium and zirconium are both used in nuclear reactors and nuclear submarines. Both hafnium and zirconium must be in the pure form in order to work effectively, this leads to the production of hafnium-free zirconium and, as a result, hafnium as a by-product. Hafnium is used in nuclear control rods due to its high thermal neutron absorption cross section (Bedinger, 2016).

Super alloys containing hafnium can contribute to lower vehicle weights and thus contribute to increased energy efficiency in the transport sector. Still, the relevance of this effect depends very much on the number of vehicles where such super alloys can actually be used in spite of the relative high price.

Data on hafnium supply, demand and reserves are not provided by statistics (European Commission, 2014); the figures available are in general individual estimates that are not necessarily aligned with each other. Deposits of heavy metals sands, which are

commercially recoverable, are found in China, Malaysia, Thailand, India, Sri Lanka, Australia, South Africa, Madagascar, and the US. World reserves for hafnium are not recorded, but can be estimated from those of zirconium. In the EU, hafnium reserves are reported for the Norra-Kaerr deposit in Sweden (6,800 tonnes).

Global production of hafnium between 2012 and 2016 amounted on average to . 70 tonnes per year. The only reported producers of hafnium are France, United States, Ukraine, Russia and China.

There is no relevant end-of-life (EOL) recycling of hafnium.

The supply of hafnium is basically dependent on a minimum future demand for zirconium by the nuclear industry. Beside a very high concentration of supplier countries, there is also a clear concentration on few hafnium producers (companies and plants); this means that the global supply chain of hafnium is vulnerable to supply shortfall of individual countries and/or companies.

## **12.2 Market analysis, trade and prices**

---

### **12.2.1 Global market analysis and outlook**

Hafnium is as by-product of a certain part of the zirconium production. At the zirconium metal purification, which is a required process step for zirconium that is used in the nuclear industry, hafnium is accumulated. There are no further viable ways to produce hafnium, therefore the demand for purified zirconium by the nuclear industry implies an upper limit for the hafnium production.

The two largest producers are France and the United States, with comparable average annual output in the period 2012-2016. China, with an average market share of 3% in the same period, plans to increase its nuclear power development. This is likely to result in an increase in demand for nuclear-grade zirconium and hafnium (Bedinger, 2016). Overall it is estimated that hafnium demand for nuclear applications will increase by 4% annually (Moss *et al.*, 2011). It must be noted that, given the interdependency of supply and demand of zirconium and hafnium from the nuclear industry, an expansion of the nuclear energy industry should also result in increased production.

Ukraine showed for the period 2012-2016 an average production of 1 tonne per year (< 1%). The continuation of the Ukrainian hafnium production in the future was considered uncertain. Alternatively, the raw materials related to the hafnium production could be exported to Russia. India and China have some low-volume hafnium production for domestic use but do not export it (Lipmann Walton & Co Ltd., 2012).

The demand and supply are expected to grow in future (

Table 63). Demand in hafnium is expected to increase by 3.6% for alloys in aerospace and by 5% for non-aerospace super alloys (Moss *et al.*, 2011). For nuclear control rods, demand is expected to increase by 4%; a 3% increase is expected for all other applications.



**Table 63: Qualitative forecast of supply and demand of hafnium**

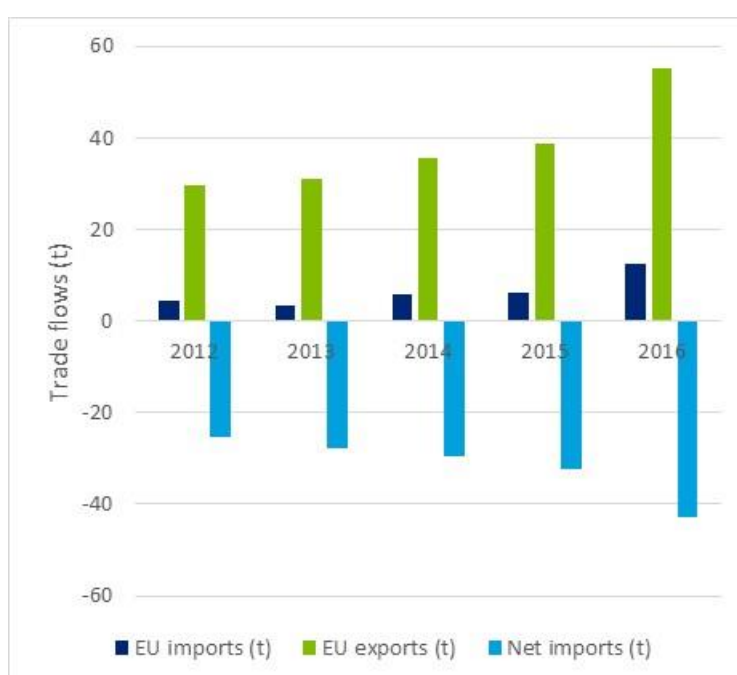
Materials	Criticality of the material in 2020		Demand forecast			Supply forecast		
	Yes	No	5 years	10 years	20 years	5 years	10 years	20 years
Hafnium	X		+	+	?	+	+	?

### 12.2.2 EU trade

For the purpose of this assessment, hafnium metal at processing stage is analysed. The product group codes covering hafnium metal are CN 8112 92 10, "Unwrought hafnium "celtium"; hafnium powders; hafnium waste and scrap (excl. ash and residues containing hafnium)" and CN 8112 99 20 "Articles of hafnium "celtium" and germanium, n.e.s.".

United States (2.3 tonnes per year, 35%), United Kingdom (1.5 tonnes per year, 24%), the Russian Federation (1 tonne per year, 15%) and China (0.8 t per year; 12%) are the most important suppliers of hafnium metal to the EU (all values relate to the average for the period 2012-2016). Together they make up almost 90% of the 6.4 tonnes per year of the average imports to the EU (see Figure 150). Ukraine follows with 8%.<sup>106</sup> The import structure is very volatile: From the nine import countries, the EU imported only from the four largest importers without interruptions in the period covered. At the same time, the average annual imports grew drastically from 3.3 tonnes in 2013 to 12.4 tonnes in 2016 (Figure 149).

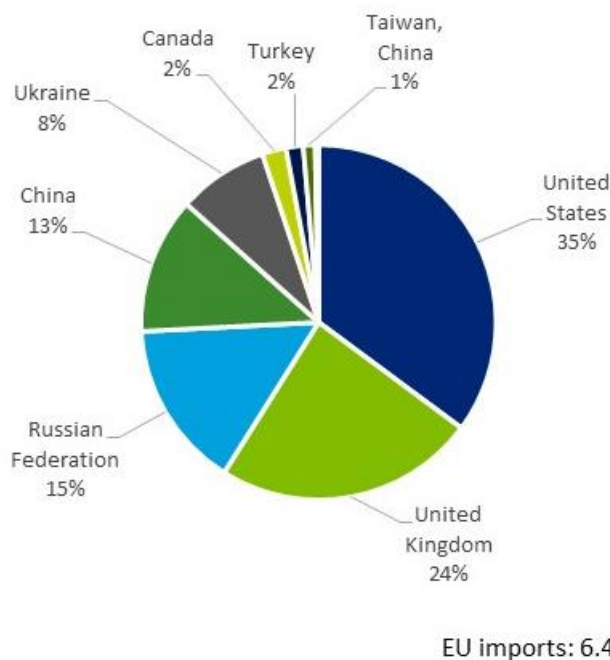
The volumes of internationally traded hafnium are small. They are generally volatile, but from 2013 to 2016 both imports and exports grew steadily (Figure 149).



**Figure 149: EU trade flows for hafnium, 2012-2016 (Eurostat, 2019)**

<sup>106</sup> EU trade is analysed using product group codes. It is possible that materials are part of product groups also containing other materials and/or being subject to re-export, the "Rotterdam-effect". This effect means that materials can originate from a country that is merely trading instead of producing the particular material.

The exports are in average for the period 2012-2016 six times larger than the imports. The dominant destination of the EU exports (22.7 tonnes per year, 60%) are imported by the United States<sup>107</sup>, followed by the United Kingdom (8.7 tonnes per year, 23%).



**Figure 150: EU imports of hafnium oxides, average 2012-2016 (Eurostat, 2019)**

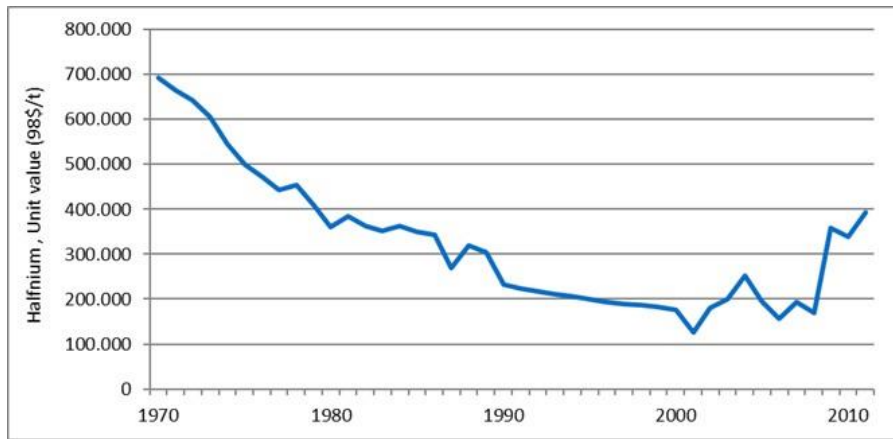
At the moment, there are no export quotas or prohibition in place between the EU and its suppliers with the exception of Russia<sup>108</sup> (OECD, 2016). From the EU's suppliers, only Russia has an export tax ( $\leq 25\%$ ) (OECD, 2016). There is a general trade agreement in place with Ukraine.

### 12.2.3 Prices and price volatility

Hafnium metal is not traded publicly, therefore worldwide data and price trends are not readily available. Figure 151 shows that there has been a significant increase in price since the early 2000s, following a long decline in prices since 1970 given the maturation of the hafnium market (prices given in constant 98US\$ prices).

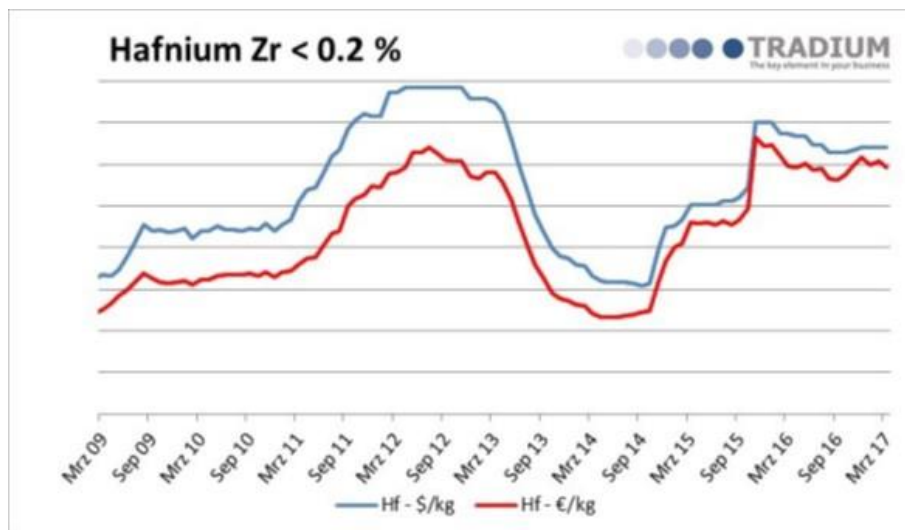
<sup>107</sup> The imports of unwrought hafnium by the US are in 2015 and 2016 largely dominated by France and Germany.

<sup>108</sup> Although China has put an export quota of 230 tonnes, which is practically irrelevant due to the high threshold.



**Figure 151: Global developments in price of hafnium, average constant prices (98 US\$) for 1970-2013 (USGS, 2016)**

The average price between 2011 and 2015 of bulk zirconium shipped from Australia was US\$1,511.00 per tonne (DERA, 2016). In the last decade, the price volatility is medium. In the period 2009-2017, the maximum price (ca. €1,900 per kilogram) was about double the minimum price (ca. €850 per kilogram) (Figure 152).



**Figure 152: Historical hafnium pricing, nominal prices March 2009-March 2017 (after ALKANE, 2017)**

## 12.3 EU demand

### 12.3.1 EU demand and consumption

The annual apparent consumption of hafnium in the EU was 3.4 tonnes in 2016. As there is a lack of updated production data, the EU consumption cannot be determined for the earlier years, therefore this value is used as proxy for the period 2012-2016. However, small commodity markets like the hafnium market tend to be very volatile, thus the validity of the consumption figure for the whole period is uncertain. For example, the US imports increased within the above-mentioned period from 24 tonnes per year to 180 tonnes per year (Bedinger, 2016). The figures imply that the hafnium consumption in the US exceeded the EU figure by far in 2016.

### 12.3.2 Uses and end-uses of Hafnium in the EU

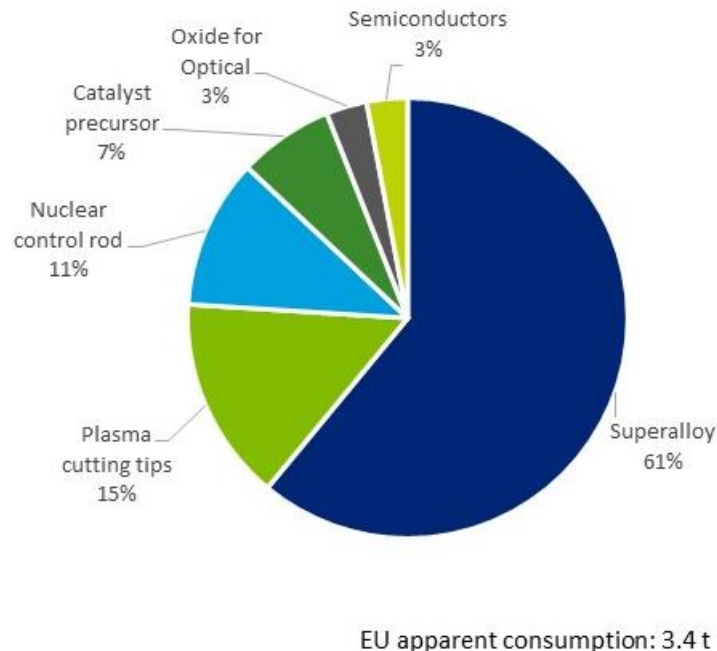
Figure 153 shows that the uses of hafnium metal; super alloys used in the aerospace industry are the major output (Lipmann Walton & Co Ltd., 2012). The nuclear applications are listed as “machinery parts”, as they are allocated to NACE 28, manufacturing of machinery.

The major applications for hafnium can be described in more detail as follows:

- Super alloys (61%): the major application for hafnium is as an alloy addition in polycrystalline nickel-based super alloys; for example, MAR-M 247 alloy contains 1.5% hafnium. These alloys are used in the aerospace industry both in turbine blades and vanes but also in industrial gas turbines. The super-alloy industry requires the purest form of hafnium, crystal bars, with low zirconium content. Demand and supply for this form of hafnium approximately equal, making the sector volatile.
- Nuclear control rods (11%): hafnium and zirconium are both used in nuclear reactors and nuclear submarines. Both hafnium and zirconium must be in the pure form in order to work effectively, this leads to the production of hafnium-free zirconium and, as a result, hafnium as a by-product. Hafnium is used in nuclear control rods due to its high thermal neutron absorption cross section (Bedinger, 2016).

Other uses of hafnium are refractory ceramic materials, microchips and nozzles for plasma arc cutting.

The global consumption of hafnium in 2016 is estimated to 67 tonnes (ALKANE, 2017). The EU apparent consumption is calculated as about 3.4 tonnes in 2016 (average 2012-2016).



**Figure 153: Global end uses of hafnium in 2016 (ALKANE, 2017)**

Relevant industry sectors are described using the NACE sector codes (Eurostat, 2016c). The calculation of economic importance is based on the use of the NACE 2-digit codes and the value added at factor cost for the identified sectors (Table 64). The value added data correspond to 2012-2016 average figures.

**Table 64: Hafnium applications, 2-digit NACE sectors, associated 4-digit NACE sectors, and value added per sector (Eurostat, 2019)**

<b>Applications</b>	<b>2-digit NACE sector</b>	<b>4-digit NACE sector</b>	<b>Value added of sector (M€)</b>
Superalloys	C24 - Manufacture of basic metals	24.45 Other non-ferrous metal production	55,426
Plasma cutting tips	C25 - Manufacture of fabricated metal products, except machinery and equipment	25.73 Manufacture of dyes and pigments	148,351
Nuclear control rod	C25 - Manufacture of fabricated metal products, except machinery and equipment	25.45 Manufacture of other tanks, reservoirs and containers of metal	148,351
Catalyst precursor	C20 - Manufacture of chemicals and chemical products	20.13 Manufacture of bodies (coachwork) for motor vehicles; manufacture of trailers	105,514
Oxide for Optical	C26 - Manufacture of computer, electronic and optical products		65,703
Semiconductors	C26 - Manufacture of computer, electronic and optical products	26.6 Manufacture of engines and turbines	65,703

### 12.3.3 Substitution

In superalloys, hafnium can be substituted by other alloy metals, such as magnesium, cobalt, chromium, niobium and tantalum, based on a kind of similarity in performance (corrosion resistance, thermal stress) (Bedinger, 2016). In certain superalloys, zirconium can be used interchangeably with hafnium (USGS, 2018), while showing a lower price. Chromite and olivine can be used instead of zircon for some foundry applications (USGS, 2018).

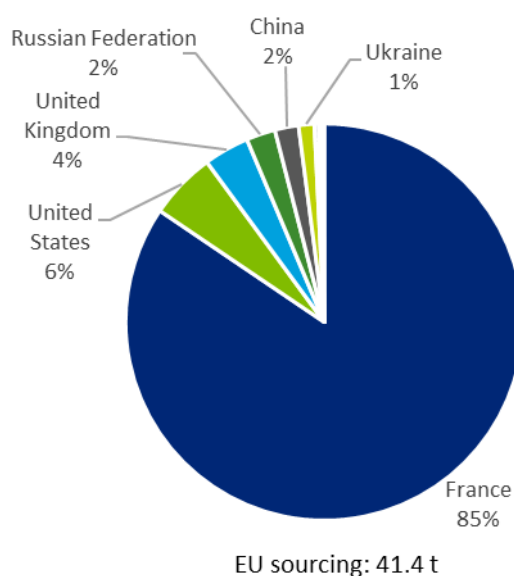
In nuclear applications, it is a long-standing option to substitute hafnium with silver-cadmium-indium control rods (Graves, 1962; USGS, 2018). This option is well-established in numerous nuclear powerplants. Beyond, niobium (columbium), stainless steel, and tantalum provide limited substitution in nuclear applications (USGS, 2018).

Zirconium can substitute hafnium in catalyst precursor applications. Titanium and synthetic materials may substitute in some chemical processing plant applications (USGS, 2018). Dolomite and spinel refractories can also substitute for zircon in certain high-temperature applications.

## 12.4 Supply

### 12.4.1 EU supply chain

France is the world major producer of hafnium, with 35 tonnes of annual production in 2016; correspondingly it is the dominant source of the EU (88%). Given the substantial domestic supply and the limited consumption, there is no import reliance of the EU. Figure 154 presents the EU sourcing<sup>109</sup> data for hafnium. (ALKANE, 2017; Eurostat, 2019)



**Figure 154: EU sourcing of hafnium, average 2012-2016 (ALKANE, 2017; Eurostat, 2019)**

Supply of hafnium is heavily dependent on the nuclear industry and its demand for pure zirconium. This is because production of zirconium requires the separation of the two metals, to allow the extraction of hafnium as by-product. This implies a dependence of hafnium supply on the zirconium market, in particular the zirconium used in nuclear control rods.

Following the Fukushima accident (2011) many countries, such as Germany, Belgium and Switzerland, have reconsidered their nuclear energy policies and decided to step out of the domestic nuclear energy supply. This has possible consequences on also on the (domestic) hafnium supply, however, most countries remain committed to their energy programs with nuclear energy (Hayashi & Hughes, 2012).

Given the geographical concentration of hafnium production, it is remarkable that export restrictions with possible effect on hafnium are widely recorded by OECD (2016). This phenomenon can be explained by the trade code applied for the analysis. The related 6-digit CN product group (code 8112 92), contains also niobium, gallium, indium, vanadium and germanium. Most of the countries applying these exports restrictions<sup>110</sup> are no

<sup>109</sup> EU sourcing = domestic production + imports

<sup>110</sup> According to the trade database of the OECD, Jamaica, Rwanda, Burundi, Indonesia, Kenya issued a prohibition for CN 8112 92. Export taxes are issued by Morocco (7.5%), Russia (6.5%), Argentina (5%), combined with a licensing requirement. Vietnam even has a tax rate around 30% on average of the abovementioned unwrought metal. The restrictions on CN 6-digit level might affect hafnium supply, but also might be a statistical anomaly that is not relevant in international trade in the coming years.

relevant EU sources for hafnium in the period 2012-2016. Russia with almost 0.9 tonnes per year has applied an export tax rate of 6.5%.

## 12.4.2 Supply from primary materials

### 12.4.2.1 Geology, resources and reserves of hafnium

**Geological occurrence:** The presence of hafnium in the earth's crust is somewhat rare, with 5.3 ppm<sup>111</sup> upper crustal abundance (Rudnick & Gao, 2003). Hafnium does exist in all silicate rocks and sediments, but in very low concentrations. It is not present in nature in its elemental form. The only mineral known with hafnium as major constituent is hafnon ((Hf,Zr)SiO<sub>4</sub>).

The occurrence of hafnium is attended by zirconium, which is about 25 times more abundant in earth's crust (132 ppm). Commonly these two elements are combined in solid solution with each other. The two major sources of zirconium and hafnium are zircon (ZrSiO<sub>4</sub>)<sup>112</sup> and baddeleyite (ZrO<sub>2</sub>), in which hafnium is normally present 1.5-3.0 wt%.

Essentially, all hafnium comes from zirconium ores. During the processing of these ores, hafnium is processed as by-product (Zr-Hf ratio is about 50:1). Globally, there exist today three predominant ore types that are relevant zirconium and hafnium sources: heavy mineral sands (HMS), carbonatites and to a minor degree peralkaline intrusions. Zircon sand is obtained from the processing of HMS to recover the titanium minerals rutile and ilmenite.

**Global resources and reserves<sup>113</sup>:** Data on hafnium supply, demand and reserves are not recorded; the figures available are generally estimates (European Commission, 2014). Deposits of heavy metals sands, which are commercially recoverable, are found in China, Malaysia, Thailand, India, Sri Lanka, Australia, South Africa, Madagascar, and the United States. World reserves for hafnium are not recorded, but can be estimated from those of zirconium. Table 65 shows the estimated world reserves of zircon (Bedinger, 2016). USGS estimates world resources of hafnium associated with those of zircon and baddeleyite as exceeding 1,000,000 tonnes.

---

<sup>111</sup> parts per million

<sup>112</sup> Zircon with unusually high hafnium content is called alvite [(Hf,Th,Zr)SiO<sub>4</sub>·H<sub>2</sub>O].

<sup>113</sup> There is no single source of comprehensive evaluations for resources and reserves that apply the same criteria to deposits of hafnium in different geographic areas of the EU or globally. The USGS collects information about the quantity and quality of mineral resources but does not directly measure reserves, and companies or governments do not directly report reserves to the USGS. Individual companies may publish regular mineral resource and reserve reports, but reporting is done using a variety of systems of reporting depending on the location of their operation, their corporate identity and stock market requirements. Translations between national reporting codes are possible by application of the CRIRSCO template.<sup>113</sup>, which is also consistent with the United Nations Framework Classification (UNFC) system. However, reserve and resource data are changing continuously as exploration and mining proceed and are thus influenced by market conditions and should be followed continuously.

**Table 65: Global reserves of zircon reserves in year 2016  
(Data from Bedinger, 2016)**

Country	Zirconium Reserves (tonnes)	Percentage of total (%)
Australia	51,000,000	65
South Africa	14,000,000	18
Other countries	7,200,000	9
India	3,400,000	4
Mozambique	1,100,000	1
China	500,000	1
United States	500,000	1
Indonesia	N/A	N/A
World total (rounded)	78,000,000	100

**EU resources and reserves<sup>114</sup>:** There are no resources documented in the EU, and the single hafnium reserve in the EU reported is Norra Kärr in Gränna, Sweden<sup>115</sup>. Norra Kärr is a rare earths deposit, which contains beside REEs also zirconium, hafnium, uranium and thorium (GBM, 2015). At the Minerals4EU website, no data is available on resources and reserves in Europe (Minerals4EU, 2019).

**Table 66: Reserve data for the EU**

Country	Reporting code	Quantity	Unit	Grade	Code Resource Type
Sweden	CIM Guidelines	23,571	ktonnes	0.0286%	Probable

#### 12.4.2.2 World and EU mine production

Hafnium is extracted as by-product from zirconium recovery routes. The world annual hafnium production from zirconium ores is about 71 tonnes in 2016. Due to lack of repeated production data, this value has been used as average for the period 2012-2016 in the calculation for the criticality assessment.

#### 12.4.3 Supply from secondary materials/recycling

##### 12.4.3.1 Post-consumer recycling (old scrap)

According to the results of the recent Material System Analysis on Hafnium<sup>116</sup>, the EoLRIR (End-of-Life Recycling Input Rate) is calculated to 0% (see Table 67) (European Commission, under publication). Currently, there is little information available on hafnium

<sup>114</sup> For Europe, there is no complete and harmonised dataset that presents total EU resource and reserve estimates for hafnium. The Minerals4EU project is the only EU-level repository of some mineral resource and reserve data for hafnium, but this information does not provide a complete picture for Europe. It includes estimates based on a variety of reporting codes used by different countries, and different types of non-comparable datasets (e.g. historic estimates, inferred reserves figures only, etc.). In addition, translations of Minerals4EU data by application of the CRIRSCO template is not always possible, meaning that not all resource and reserve data for hafnium the national/regional level is consistent with the United Nations Framework Classification (UNFC) system (Minerals4EU 2019). Many documented resources in Europe are based on historic estimates and are of little current economic interest. Data for these may not always be presentable in accordance with the UNFC system. However, a very solid estimation can be done by experts.

<sup>115</sup> <https://leadingedgematerials.com/norra-karr/>

<sup>116</sup> At the time of authoring this factsheet, the Material System Analysis (MSA) on Hafnium was still work in progress. In this sense, the results used for the calculations were preliminary.



recycling. Recycling of superalloys containing hafnium would translate into hafnium recycling, however, experts assessed at the validation workshop that there is no information available on such recycling. It is likely that currently little to no post-use EOL recycling of hafnium is being carried out, given its contamination in the nuclear industry and the low percentage content in superalloys. UNEP reports that the end-of-life recycling rate is lower than 1% (UNEP, 2011). There are no indications that this has changed since then. Hafnium metal recycling is considered insignificant in the United States (Bedinger, 2016).

**Table 67: Material flows relevant to the EoL-RIR of Hafnium, average 2012-2016<sup>117</sup> (EC 2019)**

MSA Flow	Value (t)
B.1.1 Production of primary material as main product in EU sent to processing in EU	n/a
B.1.2 Production of primary material as by product in EU sent to processing in EU	n/a
C.1.3 Imports to EU of primary material	n/a
C.1.4 Imports to EU of secondary material	n/a
D.1.3 Imports to EU of processed material	4.9
E.1.6 Products at end of life in EU collected for treatment	4.6
F.1.1 Exports from EU of manufactured products at end-of-life	n/a
F.1.2 Imports to EU of manufactured products at end-of-life	n/a
G.1.1 Production of secondary material from post consumer functional recycling in EU sent to processing in EU	n/a
G.1.2 Production of secondary material from post consumer functional recycling in EU sent to manufacture in EU	n/a

#### 12.4.3.2 Industrial recycling (new scrap)

Given the existence of hafnium as a by-product of titanium and zirconium, it is likely that hafnium waste from production processes is reintroduced in the process. At the validation workshop experts assessed that there is no information available on recycling of superalloys.

#### 12.4.4 Processing of Hafnium

Hafnium is extracted from hafnium bearing zirconium ores. As the demand for these ores has been larger for zirconium than for hafnium, and due to the ratio between hafnium and zirconium prices, hafnium is always retrieved as a by-product of the zirconium processing. Hafnium is typically found in zirconium ores with zirconium to hafnium ratios of approximately 50:1.

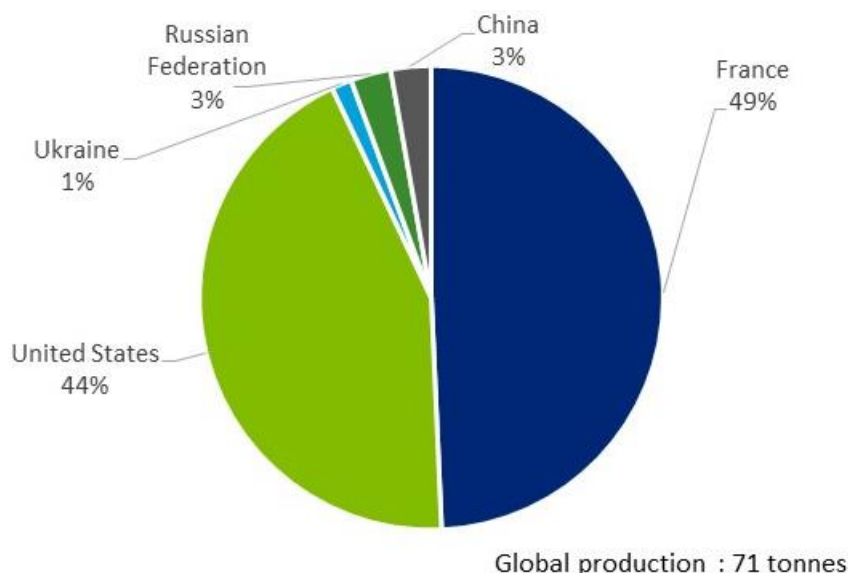
After crushing, milling and roasting the ore, the material is leached and undergoes a solvent extraction. From this solution, zirconium and hafnium are extracted, and potentially niobium is recovered. The hafnium is then transferred to hafnium oxide (HfO<sub>2</sub>). (ALKANE, 2017)

The separation of the pair zirconium and hafnium is difficult due to the similarity of their chemical properties such as atomic radius, ionic radius and electronegativity. Several methods have been applied to separate this ionic pair. Such methods include fractional crystallization, ion exchange, fractional distillation, thermal diffusion, solvent extraction and electrochemical separation (Felipe et al., 2013).

<sup>117</sup> The work carried out in 2019 increased the resolution of the MSA system. Therefore, there are changes in flows in comparison with the previous MSA methodology. B1.1 and B1.2 in the table is the result of the EU extraction after exports (MSA flows B1.1 + B1.2 – B1.3); C1.4 incorporates all secondary raw material imported to the EU both for the processing and manufacturing stages (MSA flows C1.4 and D1.9). D1.3 Incorporates imports to the EU of both semi-processed and processed material stages (MSA flows D1.3 and C1.8).

The global hafnium production is geographically highly concentrated. Most of the global production of hafnium (i.e. refining of zirconium) is done in France and the United States (Figure 155), whereat the production of high purity zirconium for nuclear applications is dominating. For about 2008 and 2012, respectively, AREVA, the only French producer, reported a production of 50 tonnes per year, however, the representativity of this value could not be assessed and the reference year remained unclear, thus it was not considered in the criticality assessment (AREVA, 2008).

The global refined hafnium production is shown in Figure 155.



**Figure 155: Global refined hafnium production in 2016 (ALKANE, 2017)**

Beside a very high concentration of supplier countries, there is also a clear concentration on few hafnium producers (companies and plants), thus the global supply chain is vulnerable accordingly. Relevant producers in 2016 were Areva (France), ATI Wah Chang (U.S.) and Revert-Recycled (U.S.), together making up more than 90% of the global supply.

## 12.5 Other considerations

### 12.5.1 Environmental and health and safety issues

There is no comprehensive information available on health and safety issues. At the production process, hydrochloric acid vapours can leak from the processing unit, in exceptional cases of the maintenance procedures (CEZUS, 2008). This issue is commonly considered to be managed well in the extraction plants. At a safety exercise of the AREVA plant in Cezus, France, two risks were considered: firstly, the explosion of Methylchloride, a highly flammable and toxic gas, with possible effects up to a distance of 600 m, secondly the leakage of chlorine with possible effects of up to a distance of 6400 m (AREVA, 2012).

EU occupational safety and health (OSH) requirements exist to protect workers' health and safety. Employers need to identify which hazardous substances they use at the workplace, carry out a risk assessment and introduce appropriate, proportionate and effective risk management measures to eliminate or control exposure, to consult with the workers who should receive training and, as appropriate, health surveillance<sup>118</sup>.

<sup>118</sup> <https://ec.europa.eu/social/main.jsp?catId=148>

## 12.5.2 Socio-economic issues

Hafnium is not linked to any particular socio-economic issue.

## 12.6 Comparison with previous EU assessments

---

The assessment has been performed using the revised methodology introduced in the 2017 assessment. The calculation of the Supply Risk (SR) was carried out at the refining stage of the value chain, using the global HHI calculation only, because the EU is a net exporter.

Overall, the assessment results for hafnium in 2020 are similar to the 2017 results. Compared to the 2017 assessment, both economic importance and supply risk dropped slightly, while it is still assessed as critical (see Table 68).

Hafnium was assessed for the first time at the 2014 criticality assessment. In spite of an Economic Importance of 7.8, it was not considered critical due to a low Supply Risk. In 2017, there was a strong drop of the economic importance compared to 2014, mainly to the revision of the methodology, but also because the use in nuclear reactors has been additionally considered. The economic importance decreased further in 2020, whereat a new data source has been used to describe the sectoral distribution, with a different application terminology.

The supply risk shows a significant rise from 0.4 in 2014 to 1.3 in 2017. This dropped again slightly to 1.1 in 2020, mainly due to the fact that shortcomings in the trade data did not allow to include the EU-28 HHI in the calculation, like in 2017, when the global HHI was higher than the EU-28 HHI. Still, the Supply Risk indicator is above the criticality threshold due to the limited number of reported suppliers of hafnium. It must be noted that the supply risk is dependent on monopoly or quasi-monopoly situations, independent from the fact that the monopoly is in an EU or an extra-EU country.

**Table 68: The results of Economic Importance and Supply Risk for hafnium in the assessments of 2011, 2014 (European Commission, 2011; European Commission, 2014) and 2017**

Assessment	2011		2014		2017		2020	
	EI	SR	EI	SR	EI	SR	EI	SR
Hafnium	N/A	N/A	7.8	0.4	4.2	1.3	3.9	1.1

## 12.7 Data sources

---

The production data is incomplete and vague as there is only a single estimate available for 2016. For the calculation of the supply risk indicator, the global HHI only has been considered as the EU is a net exporter.

### 12.7.1 Data sources used in the factsheet

ALKANE (2019). *Hafnium. Presentation at the 6th Annual Cleantech & Technology Metals Summit. Available at: <https://de.slideshare.net/AlkaneResources/alkane-resources-hafnium-cleaner-power-and-transport-faster-more-energy-efficient-next-gen-devices> (data based on Roskill ASM internal report), accessed at 30.10.2019*

AREVA (2008). *CEZUS Jarrie. Presentation at reunion du clic le 17.06.2008.*

AREVA (2012). Plate-forme chimique de Jarrie. AREVA Etablissement CEZUS Jarrie. Exercice de securite civile, 16.10.2012. Dossier de presse de Prefet de L'Isere.

DERA (2016). Pricelist of raw materials/ [online] Available at: [http://www.bgr.bund.de/DE/Themen/Min\\_rohstoffe/Produkte/Preisliste/cpl\\_16\\_11.pdf?blob=publicationFile](http://www.bgr.bund.de/DE/Themen/Min_rohstoffe/Produkte/Preisliste/cpl_16_11.pdf?blob=publicationFile)

European Commission (2011). Critical raw materials for the EU. [online] Available at: [https://ec.europa.eu/growth/sectors/raw-materials/specific-interest/critical\\_en](https://ec.europa.eu/growth/sectors/raw-materials/specific-interest/critical_en)

European Commission (2014) Report on critical raw materials for the EU – Non Critical raw materials profiles.

European Commission (2016). DG Trade. Agreements [online] Available at: <http://ec.europa.eu/trade/policy/countries-and-regions/agreements/>

European Commission (2019). Draft MSA on Hafnium. Preliminary results of the Hafnium MSA Study. Internal document – not published. Reference date: 14 November 2019.

Eurostat (2016)a. International Trade Easy Comext Database [online] Available at: <http://epp.eurostat.ec.europa.eu/newxtweb/>

Eurostat (2016)b. Statistics on the production of manufactured goods (PRODCOM NACE Rev.2). [online] Available at: <http://ec.europa.eu/eurostat/data/database>

Eurostat (2016)c. Annual detailed enterprise statistics for industry (NACE Rev. 2, B-E). [online] Available at: [http://ec.europa.eu/eurostat/en/web/products-datasets/-/SBS\\_NA\\_IND\\_R2](http://ec.europa.eu/eurostat/en/web/products-datasets/-/SBS_NA_IND_R2)

Felipe, E. C. B., Palhares, H. G., Ladeira, A. C. Q. (2013). Separation of zirconium from hafnium by Ion Exchange. ISBN: 978-85-99141-05-2 Available at: <http://www.iaea.org/inis/collection/nclcollectionstore/public/45/075/45075421.pdf>

GBM (2015). Norra Kärr Project PFS, Gränna, Sweden. Amended & Restated Prefeasibility Study - NI 43-101 - Technical report for the Norra Kärr Rare Earth Element Deposit. Prepared For: Tasman Metals Ltd. GBM Project Number: 0465. Issued on 10.07.2015

Hayashi, M., Hughes, L. (2012). The policy responses to the Fukushima nuclear accident and their effect on Japanese energy security. Energy policy, volume 59, p.86-101. Available at: <http://www.sciencedirect.com/science/article/pii/S0301421512007410>

Lenntech (2016). Hafnium. [online] Available at: <http://www.lenntech.com/periodic/elements/hf.htm>

Minerals4EU (2019). European Minerals Yearbook. [online] Available at: [http://minerals4eu.brgm-rec.fr/m4eu-yearbook/theme\\_selection.html](http://minerals4eu.brgm-rec.fr/m4eu-yearbook/theme_selection.html), accessed at 12.11.2019

Moss, R. L., Tzimas, E., Kara, H., Willis, P., Koorosh, J. (2011). Critical Metals in Strategic Energy Technologies. JRC Scientific and technical reports. Available at: <https://setis.ec.europa.eu/sites/default/files/reports/CriticalMetalsinStrategicEnergyTechnologies-def.pdf>

Nielsen, R. H., Wilfing, G. (2010). Hafnium and Hafnium Compounds. Ullmann's Encyclopedia of Industrial Chemistry. Available at: [http://onlinelibrary.wiley.com/doi/10.1002/14356007.a12\\_559.pub2/abstract](http://onlinelibrary.wiley.com/doi/10.1002/14356007.a12_559.pub2/abstract)

Rudnick, R.L. and Gao. S. (2003). Composition of the Continental Crust. In: Treatise on Geochemistry, Volume 3. Editor: Roberta L. Rudnick. Executive Editors: Heinrich D. Holland and Karl K. Turekian. pp. 659. ISBN 0-08-043751-6. Elsevier, p.1-64.

USGS (2016) *Historical Statistics for mineral and material commodities in the United States*. Available at: <https://minerals.usgs.gov/minerals/pubs/historical-statistics/>

## 12.7.2 Data sources used in the criticality assessment

ALKANE (2019). *Hafnium*. Presentation at the 6th Annual Cleantech & Technology Metals Summit. Available at: <https://de.slideshare.net/AlkaneResources/alkane-resources-hafnium-cleaner-power-and-transport-faster-more-energy-efficient-next-gen-devices> (data based on Roskill ASM internal report), accessed at 30.10.2019

Bedinger, G, M. (2016) *Zirconium and Hafnium USGS Minerals Yearbook 2014*. Available at: <https://minerals.usgs.gov/minerals/pubs/commodity/zirconium/myb1-2014-zirco.pdf>

Eurostat Comext (2016). *International trade in goods database (COMEXT)* Available at: <http://ec.europa.eu/eurostat/data/database>

European Commission (2014). *Report on critical raw materials for the EU*. Available at: [https://ec.europa.eu/growth/sectors/raw-materials/specific-interest/critical\\_en](https://ec.europa.eu/growth/sectors/raw-materials/specific-interest/critical_en)

European Commission (2019). *MSA study on Hafnium*.

Eurostat (2016). *Annual detailed enterprise statistics for industry (NACE Rev. 2, B-E)*. [online] Available at: [http://ec.europa.eu/eurostat/en/web/products-datasets/-/SBS\\_NA\\_IND\\_R2](http://ec.europa.eu/eurostat/en/web/products-datasets/-/SBS_NA_IND_R2)

Graves, H.W., Lombardo, J. J., Theilacker, J.S. (1962). *Silver indium cadmium, a control rod material for pressurized water reactors*. *Nuclear Science and Engineering*, volume 13. Available at: <https://www.osti.gov/scitech/biblio/4811673>

Lipmann Walton & Co Ltd. (2012). *Hafnium Supply-Demand-MMTA-Brief metal statistics*. Available at: <http://www.lipmann.co.uk/articles/metal-matters/hafnium-supply-demand-mmta-brief-metal-statistics/>

OECD (2016). *Export restrictions on Industrial Raw Materials database [online]*. <http://qdd.oecd.org/table.aspx?Subject=ExportRestrictionsIndustrialRawMaterials>

UNEP (2011). *Recycling rates of metals*. Available at: [http://www.unep.org/resourcepanel/portals/24102/pdfs/metals\\_recycling\\_rates\\_110412-1.pdf](http://www.unep.org/resourcepanel/portals/24102/pdfs/metals_recycling_rates_110412-1.pdf)

Schemel, J. H. (1977). *ASTM Manual on Zirconium and Hafnium*. ASTM International. pp. 1–5. ISBN 978-0-8031-0505-8. Available at: [https://www.astm.org/DIGITAL\\_LIBRARY/STP/SOURCE\\_PAGES/STP639.htm](https://www.astm.org/DIGITAL_LIBRARY/STP/SOURCE_PAGES/STP639.htm)

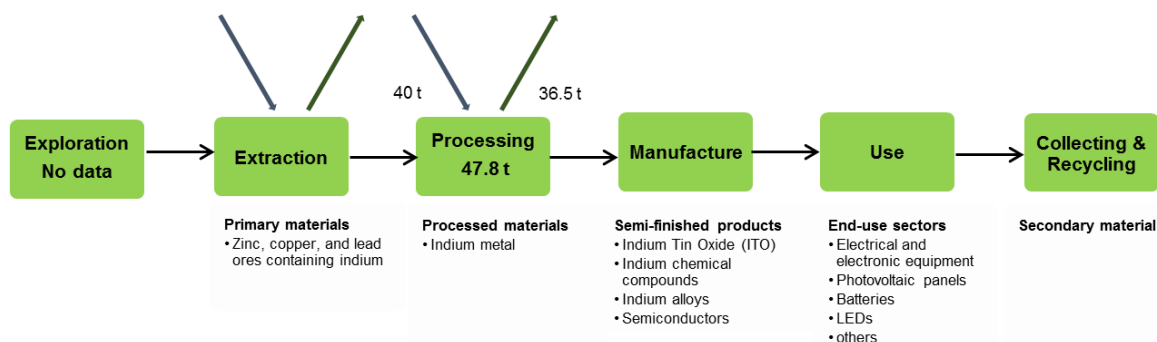
## 12.8 Acknowledgments

---

This factsheet was prepared by the JRC. The authors appreciate the support of Andreas Auberger and Monika Dittrich, Institut für Energie- und Umweltforschung Heidelberg (ifeu), for valuable input from the Material System Analysis (MSA), which was conducted at the same time in parallel. They also thank the Ad Hoc Working Group on Critical Raw Materials, in particular Asko Käpyaho (Finnish Geological Survey, GTK), as well as experts participating in the hafnium session of the SCRREEN workshop for their valuable contribution and feedback, notably Stéphane Bourg (CEA, France) and Lluís Fontboté (University of Geneva).

# 13 INDIUM

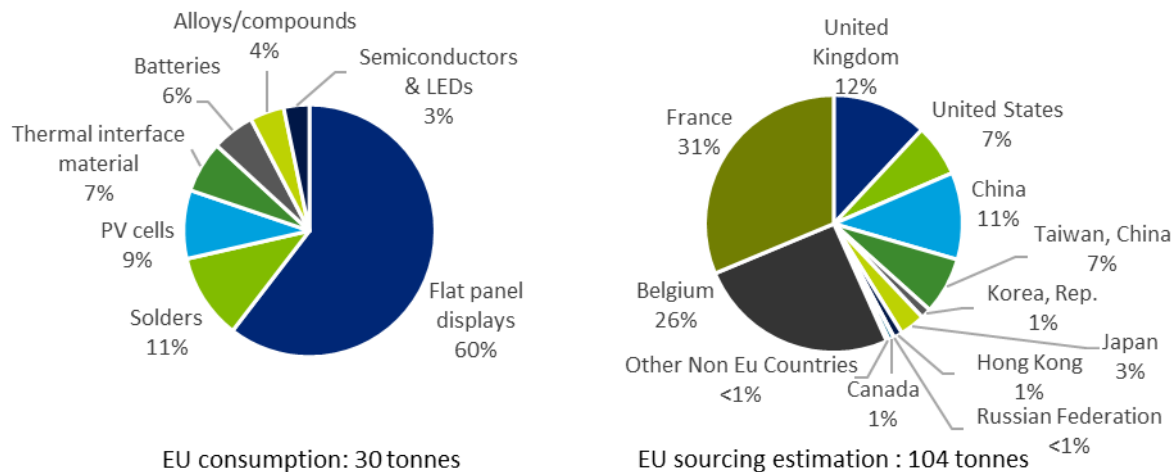
## 13.1 Overview



**Figure 156: Simplified value chain for indium, 2012-2016 for the EU, averaged over 2012 to 2016<sup>119</sup>**

Indium (chemical symbol In, atomic number 49) is a very soft, ductile and malleable silvery metal with a hardness of 1.2 on Mohs scale. It has a density of 7.31 g/cm<sup>3</sup> (similar to tin's), a low melting point of 156.6°C, a high boiling point of 2072°C and becomes superconducting at 3.37 K (-269,78°C). The most important commercial source of indium is the zinc mineral sphalerite. Approximately 95% of the refined primary indium produced in the world comes from zinc ores processing (Lokanc, M. et. al., 2015).

Indium is assessed at processing stage (indium metal), by considering trade of unwrought indium; Indium powders (trade code CN81129281)



**Figure 157: End uses of indium (SCRREEN, 2019)<sup>120</sup> and annual average EU sourcing of indium, 2012-2016<sup>121</sup>**

The worldwide market value of indium in 2019 was USD 420 million and it is expected to grow at a CAGR of roughly 4.2% over the next five years, reaching USD 540 million in 2024 (Marketwatch, 2019). Indium is traded in metal exchange. The price of indium has

<sup>119</sup> JRC elaboration on multiple sources

<sup>120</sup> Apparent consumption figure for indium is derived from adding EU production (based on the figures reported by World Mining Data, 2019) and imports and subtracting exports (imports and exports figures are based on the information reported by Eurostat-Comext, 2019)

<sup>121</sup> EU sourcing figure of indium, 104 tonnes, is the sum of EU production (based on World Mining Data, 2019) and EU imports (based on Eurostat, Comext, 2019)

decreased from USD 718 per kilogram in 2014 to USD 263 per kilogram in 2018. The collapse of Fanya Metals Exchange in China, which has accumulated large amounts of indium metal in 2015 was associated to this trend (USGS, 2016b).

Over the period 2012-2016 the EU imported 34 tonnes of indium annually, mainly from the United Kingdom (13% of EU sourcing), followed by the United States (5% of EU sourcing) and China (4% of EU sourcing). Indium was domestically produced in the EU in France (29.25 tonnes per year, representing 31% of EU sourcing) and Belgium (23.75 tonnes per year, 26% of EU sourcing).

The major use of indium in the EU is as indium-tin oxide (ITO) in flat panel devices (FPDs). Other applications include alloys and solders, thin film solar panels, thermal interface materials, light emitting diodes (LEDs) and laser diodes. In transparent conducting oxides (TCOs) used in flat panels displays and in amorphous silicon and CdTe PV cells, indium can be replaced by other TCOs. There is no commercially available substitute for indium in semiconductors (CIGS and CIS) used in thin-film solar cells.

Given its use in PV cells and in batteries, indium can play a role in enabling low-carbon energy solutions in the EU economy, contributing to achieve the objectives of the "European strategic long-term vision for a prosperous, modern, competitive and climate neutral economy"<sup>122</sup>.

Indium resources and reserves are generally derived from zinc resources and reserves data using an average indium content of zinc ores. A study undertaken by the Indium Corporation estimated that primary indium resources and reserves in identified base metal mines amounted to approximately 50,000 tonnes of indium, with some 47% in China and the Commonwealth of Independent States (CIS), and 53% in other countries (Mikolajczak, 2009). In Europe, most of the indium mineralisation is located in Variscan units and, to a small extent, in Proterozoic (Sweden), Caledonian and Alpine formations. Indium resources were also reported to exist in Austria, Bulgaria, Czechia, Germany, Greece, Hungary, Ireland, and Portugal (Lauri, L. et. al., 2018).

World production of indium over 2013-2016 was 827 tonnes, with majority of production in China (48%), followed by South Korea (21%) (WMD, 2019). The EU production of indium accounted for 9% of the global supply over the same period (WMD, 2019).

World secondary refined indium production resulted almost exclusively from the recycling of manufacturing waste (new scrap) rather than recovery from end-of-life (EoL). Indium is most commonly recovered from ITO scrap, for example in Japan and the Republic of Korea (USGS, 2019). Precise data on the amount of secondary indium recovered from scrap are not available, though are estimated to exceed primary indium production (European Commission, 2017). However, when it comes to old scrap, only a very little share of old scrap (1%) is recycled worldwide (UNEP, 2013).

Prior to 2017, China imposed 2% export tax on indium and an export quota at 237 tonnes on average. Both measures have been removed in 2017. China has applied export licences since January 2017 (European Commission, 2017).

Indium tin oxide and indium phosphide are both subject to registration under the EU REACH regulation (ECHA, 2019a) (ECHA, 2019b).

---

<sup>122</sup> COM(2018) 773 final A Clean Planet for all. A European strategic long-term vision for a prosperous, modern, competitive and climate neutral economy

## 13.2 Market analysis, trade and prices

### 13.2.1 Global market analysis and outlook

Indium-tin oxide (ITO) was the leading global use of indium (USGS, 2016a). China and Korea were the major producers of ITO over the period 2013-2016, and at the same time, together with Japan and Taiwan a major consumer of indium tin oxide. The main ITO producers, are, among others, Samsung Corning Precision materials Korea Co. Ltd. and Heesung metal Ltd. in the Republic of Korea and JX nippon mining & metals Corp. and mitsui metal mining Co. Ltd. in Japan (USGS, 2016b). All flat panel displays (FPDs) manufacturing takes place in Japan, South Korea and China. Ex-Asia, indium was mostly used in the manufacturing of non-ITO applications such as solders, alloys, and compound semiconductors.

There is no solid forecast for demand and supply of indium reported from experts. The trend in the use of indium in flat display and PV panel applications would require a slightly decreasing amount of indium towards 2035. The future indium demand would most likely follow the trends shaped by flat displays application. Several factors may contribute to accelerating the decrease in indium requirements, such as the ban of the import of e-waste from EU by other countries, increase in ITO sputtering process efficiency, recycling cost of end-of-life products and legal barriers to disposal and incentive measures in favour of reuse, repair and refurbished items. On the contrary, shift in user experience design towards display interaction may reduce the decrease in indium requirements (Monnet, A. et. al., 2018).

According to USGS (2016b), on the supply side, China is expected to continue to be the main global supplier of primary indium metal.

**Table 69: Qualitative forecast of supply and demand of indium**

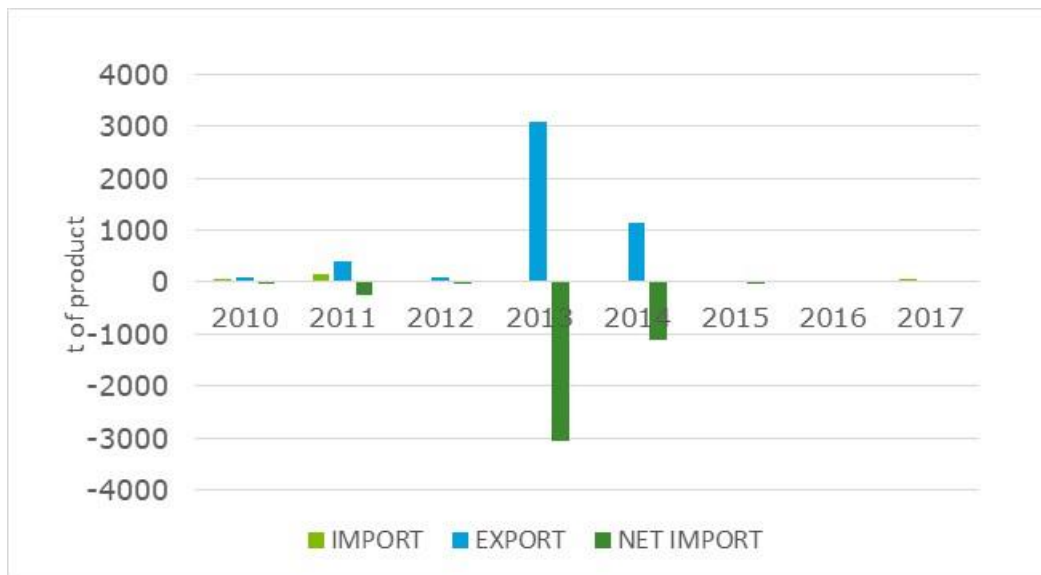
Materials	Criticality of the material in 2020		Demand forecast			Supply forecast		
	Yes	No	5 years	10 years	20 years	5 years	10 years	20 years
Indium	x		?	?	?	?	?	?

### 13.2.2 EU trade

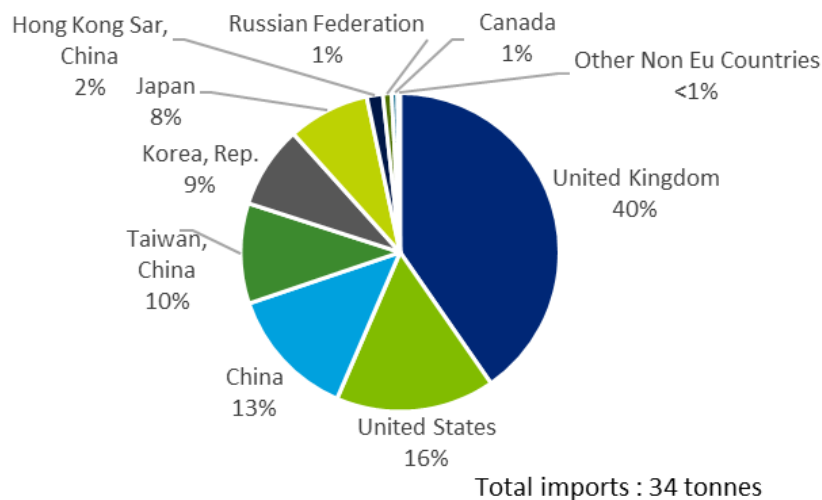
The trade flow data of indium from Eurostat indicated that over the period 2012-2016 EU was a net exporter of Indium (see Figure 158). Over the period 2012-2016 the EU imported 34 tonnes per year of indium metal, mainly from the United Kingdom (13% of EU sourcing), followed by the United States (5% of EU sourcing) and China (4% of EU sourcing) (Figure 159).

There was a high variation in export quantity of Indium in 2013 and 2014 which makes the reliability of the trade data questionable (CRM Alliance, 2019). Therefore, for the purpose of this criticality assessment, the EU trade figure for indium was calculated on the average of the year 2012, 2015 and 2016.





**Figure 158: EU trade flows for indium metal (Eurostat, 2019a)**



**Figure 159: EU imports of indium by country (yearly average 2012-2016) (Eurostat, 2019a)**

### 13.2.3 Prices and price volatility

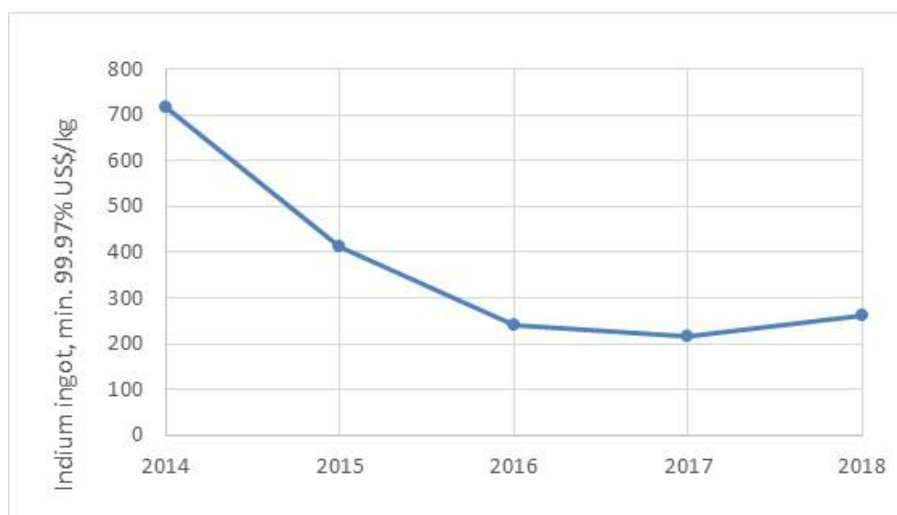
The price trend of indium ingots from 2014-2018 is shown in Figure 160. Prices of indium were supported by stockpiling at the Fanya Metals Exchange (FME) which was established in 2011 in Kunming, China, until its collapse in August 2015.

In 2015, Kunming municipal government announced a criminal investigation against FME for illegal fund raising. Since the collapse of FME, indium prices have dropped from USD 700 to USD 200 per kilogram in 2018 (USGS, 2016a).

Earlier in 2019, prior to the retrial against the FME’s owner at the Yunnan superior court, the Kunming court held two auctions of stocks from FME. The Yunnan court's decision indicates that the authorities are likely to hold more auctions of Fanya stocks in the future.

Approximately 3,600 tonnes of indium metal (equivalent to more than 4 years of primary production) were accumulated in FME warehouses (Argus media, 2019). Market

participants have warned that a possible sudden release of these stocks could cause a price collapse in the spot market of indium (Argusmedia, 2019).



**Figure 160: Indium prices from 2014 to 2018 in USD per kg of ingots, min. 99,97 % (free market, in warehouse) (DERA pricemonitor)**

## 13.3 EU demand

### 13.3.1 EU demand and consumption

The EU domestic production of indium was 70.5 tonnes per year for the average of the years 2013-2017. The EU import of indium was 34,5 tonnes per year and the exports was 40 tonnes per year. As reported in "EU Trade" section, due to the data anomaly, the reported trade figures refer to the average of 2012, 2015 and 2016. Based on these figures, the estimated EU apparent consumption of indium (production+imports–exports) was 64 tonnes per year, representing 9% of the indium produced globally on average 2013-2016. The figures also suggested that the EU was a net exporter of primary indium. However, this figure may not reflect the full picture of the EU situation, since there was no official information on the quantity of indium produced from secondary supply.

### 13.3.2 Uses and end-uses of indium in the EU

Indium manufactured in the EU is mainly used in form of ITO in various display technologies for electronic equipment and to a lesser extend in smart windows for architectural and automotive glasses. Other uses comprise alloy additions for batteries, solders and to a smaller fraction in semiconductor compounds for solar cells and LEDs.

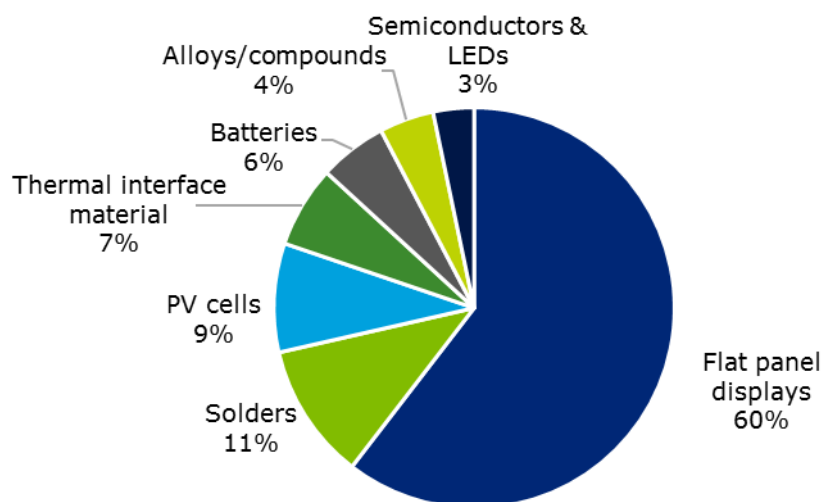
Indium is used for the following application:

- The primary application of indium is as ITO thin films. ITO is a mixture of indium (III) oxide ( $\text{In}_2\text{O}_3$ ) and tin (IV) oxide ( $\text{SnO}_2$ ), typically 90%  $\text{In}_2\text{O}_3$ , 10%  $\text{SnO}_2$  by weight. When deposited as thin film on glass or clear plastic it functions as a transparent electrode. ITO is used in flat-panel displays (FPDs) - whether liquid crystal displays (LCDs), plasma display panels (PDPs) or OLED displays (organic light emitting diodes) - for televisions, laptops, notebooks and mobile phones. ITO thin films are also applied to car and aircraft windshields for defogging and deicing. They were still used to make touch screen cathode ray tubes (CRTs) found, e.g., in some banks ATMs, although these are slowly being phased out (Vulcan, 2013). All

flat panel displays are made in Japan, South Korea and China. This application accounted for 56% of the global indium use in 2013 (Indium Corporation, 2013).

- Indium is used as a low-temperature solder and a lead-free solder, either as alloys or as pure metal. Indium reduces the melting point in solder alloys and can improve the thermal fatigue performance of solders used in the electronics industry, even in a small amount. Its ductility and malleability are retained at cryogenic temperatures so that an assembly can maintain an effective seal, even in harsh environments. Indium solders are also used for glass-to-glass or glass-to-metal joints.
- Indium semiconductor compounds ( $\text{CuIn}_{1-x}\text{GaSe}_2$ ) are used as a light absorber material in CIGS (Copper indium gallium diselenide) and CIS (without gallium) thin film solar cells. ITO (indium tin oxide) is used as a top transparent electrode of CIGS, amorphous silicon and CdTe cadmium telluride PV cells. The transparent conductive oxide (ITO) maximizes light transmission of the incoming light into the solar cell absorber materials (CIGS, amorphous silicon or cadmium telluride layers).
- Because of its excellent thermal conductivity and ductility, indium metal, alloys and composites are used as thermal interface materials (TIMs) in electronics devices. TIMs transfer heat generated by semiconductors to a heat sink to prevent the device from overheating. The extreme malleability of indium allows it to fill in any microscopic gaps between the two surfaces, thereby increasing heat flow.
- Indium is one of many substitutes for mercury in alkaline batteries to prevent the zinc anode from corroding and releasing hydrogen gas. Indium functions like mercury by forming zinc alloy to inhibit zinc corrosion.
- Indium is a component of low melting-point alloys which can be used for glass-to-glass or glass-to-metal joints and in a variety of other applications: in semiconductor compounds in LEDs (e.g. indium gallium nitride-InGaN), laser diodes (indium phosphide InP), etc. Relevant industry sectors are described using the NACE sector codes (Eurostat, 2019b).
- Furthermore, Indium in indium antimonide (InSb) and indium gallium arsenide (InGaAs) are used for infrared technologies. Indium phosphide (InP) is used for laser diodes.

Figure 161 presents the share of main uses of indium in the EU. The Relevant industry sectors for the application in of indium in the EU are described using the NACE sector codes (Eurostat, 2019b), presented in Table 70.



Estimated EU consumption: 64 tonnes

**Figure 161: EU end uses of indium (SCREEN, 2019). Average figures for 2012-2016 (see EU demand section).**

**Table 70: Indium applications, 2-digit and associated 4-digit NACE sectors, and value added per sector (Eurostat, 2019b)**

Applications	2-digit NACE sector	4-digit NACE sectors	Value added of sector (millions €)
Flat panel displays	C26 - Manufacture of computer, electronic and optical products	C26.2.0 - Manufacture of computers and peripheral equipment	75,260
Solders	C26 - Manufacture of computer, electronic and optical products	C26.1.1 - Manufacture of electronic components	75,260
PV cells (CIGS, CIS and CdTe)	C26 - Manufacture of computer, electronic and optical products	C26.1.1 - Manufacture of electronic components	75,260
Thermal interface material	C26 - Manufacture of computer, electronic and optical products	C26.1.1 - Manufacture of electronic components	75,260
Batteries	C27 - Manufacture of electrical equipment	C27.2.0 - Manufacture of batteries and accumulators	84,609
Alloys/compounds	C24 - Manufacture of basic metals	C24.4.5 - Other non-ferrous metal production	57,000
Semiconductors & LEDs	C26 - Manufacture of computer, electronic and optical products	C26.1.1 - Manufacture of electronic components	75,260

### 13.3.3 Substitution

Substitute options are presently available for some major indium containing applications in the EU (Tercero, et. al., 2018):

- *Flat display application:* indium-thin-oxide (ITO) is substitutable in LCDs by antimony-tin-oxide (ATO). However, antimony is no real substitute option as it is also classified as critical raw material (European Commission 2017a). For

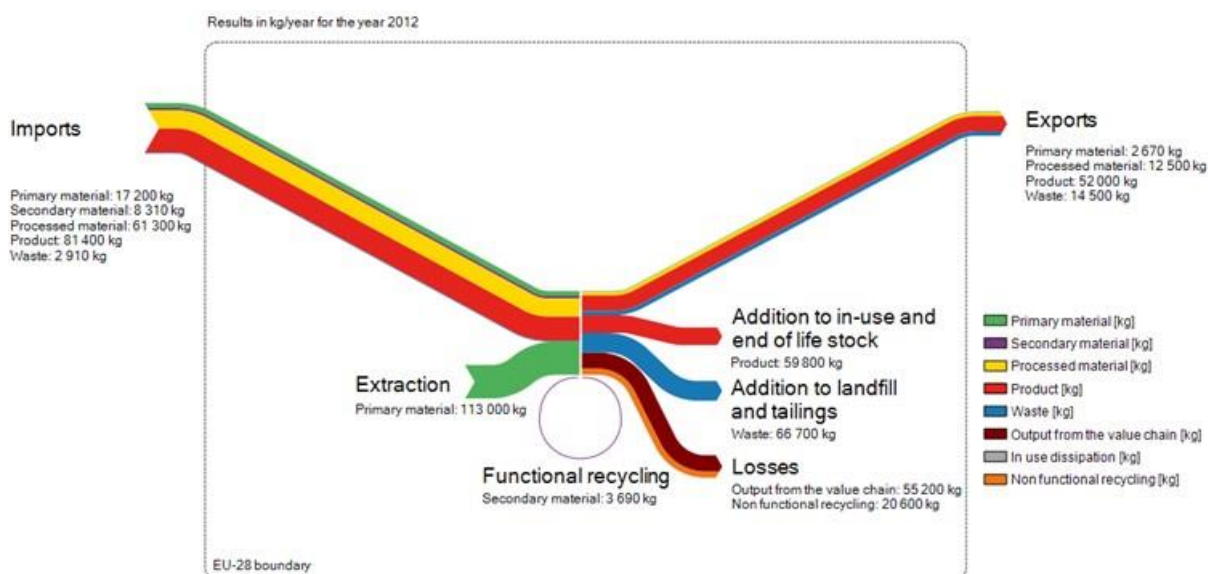
architectural glasses with low emissivity coating, ITO can be replaced by Fluorine-doped-thin-oxide (FTO). For smart window applications with double glazing (moisture protected) Aluminium-doped-Zinc-Oxide (AZO) or Zinc Oxide (ZnO) can be used for ITO. In thin film solar cells and flat panel displays, it is possible to use FTO or AZO as Transparent Conductive Oxide (TCO) instead of ITO, however not without a loss in performance with respect to conductivity and/or transparency.

- *PV cells application:* CdTe or a-Si based thin film solar cells can be used instead of CIGS/CISbased semiconductors in thin film solar cells. InP can be replaced in laser diodes by GaAs. However, Ga is also classified as critical raw material, which makes this substitute option obsolete.
- *Solder application:* Tin-bismuth alloys can replace tin-indium alloys for low temperature bonding and soldering applications. Similarly, for cryogenic sealing applications, lead-based alloys can be used instead of indium and indium-tin alloys. Hafnium replaces indium in nuclear reactor control rods. Alloy additions for batteries, solders and to a smaller fraction in semiconductor compounds for solar cells and LEDs.

## 13.4 Supply

### 13.4.1 EU supply chain

- At extraction stage, some of the zinc concentrates produced in the EU present significant indium contents. At Neves Corvo in Portugal, indium grades vary within the range 20 to 1,100 ppm per tonne in the massive zinc and lead-zinc ores of the deposit (Pinto et al., 2014). However it is not known if indium was recovered from concentrates produced within the EU during the period 2012-2016. In general, the quantity of indium recovered from zinc concentrates produced globally are not publicly reported.
- At refining stage, the EU has refining capacity, producing up to 70.5 tonnes of refined primary indium per year on average over the year 2013-2016.
- At recycling stage, the EU also has a refining capacity for secondary indium. However, these figures are not reported publicly. The total estimated EU production capacity reported for the year 2013 was 51.5 tonnes per year (Lokanc, M. et al, 2015).



**Figure 162: Simplified material system analysis diagram of indium in the EU, reference year 2012 (BioIntelligence, 2015)**

## **13.4.2 Supply from primary materials**

### **13.4.2.1 Geology, resources and reserves of indium**

#### **Geological occurrence:**

Indium is found as a trace element in some zinc, copper, lead and tin minerals but is mostly recovered from the zinc-sulphide mineral sphalerite. Indium abundance in the Earth continental upper crust is estimated at 0.056 ppm (Rudnick & Gao, 2014).

The most important deposits are volcanic and sediment-hosted base-metal sulphide deposits, which are generally characterised by high metal abundance and large tonnages. The concentration of indium in these ores is in the range 20–200 ppm. Other types of deposits containing significant and recoverable amounts of indium include polymetallic vein-type deposits, vein-stockwork deposits of tin and tungsten and epithermal deposits (Schwarz-Schampera, 2014).

#### **Global resources and reserves<sup>123</sup>:**

Being mainly recovered as a by-product of zinc production, indium resources and reserves are generally derived from zinc resources and reserves data using an average indium content of zinc ores.

A study undertaken by the Indium Corporation (Mikolajczak, 2009) estimated that primary indium resources and reserves in identified base metal mines amounted to approximately 50,000 tonnes of indium, with some 47% in China and the Commonwealth of Independent States (CIS), and 53% in other countries.

Global resources and reserves of indium calculated from global zinc resources and reserves reported by USGS (2012), using an average zinc ore indium content of 50 gram per tonne, have been estimated at 95,000 tonnes and 12,500 tonnes, respectively (Schwarz-Schampera, 2014). When also considering recoverable indium in copper deposits and using an average indium content of 10 gram per tonne, total resources and reserves amounted to 125,000 tonnes and 18,800 tonnes in 2012. The indium content of zinc deposits from which it is recovered ranges from less than 1 part per million to 100 parts per million (USGS, 2019).

NREL estimated as much as 15,000 tonnes of indium reserves are available from zinc ores, with the largest reserves located in China (Table 72).

---

<sup>123</sup> There is no single source of comprehensive evaluations for resources and reserves that apply the same criteria to deposits of indium in different geographic areas of the EU or globally. The USGS collects information about the quantity and quality of mineral resources but does not directly measure reserves, and companies or governments do not directly report reserves to the USGS. Individual companies may publish regular mineral resource and reserve reports, but reporting is done using a variety of systems of reporting depending on the location of their operation, their corporate identity and stock market requirements. Translations between national reporting codes are possible by application of the CRIRSCO template.<sup>123</sup>, which is also consistent with the United Nations Framework Classification (UNFC) system. However, reserve and resource data are changing continuously as exploration and mining proceed and are thus influenced by market conditions and should be followed continuously.

**Table 71: World indium resources and reserves calculated from global zinc and copper resources and reserves reported by USGS in 2012 (Data from Schwarz-Schampera, 2014)**

<b>Estimated world indium resources and reserves (tonnes of indium)</b>	
Resources in zinc ores	95,000
Reserves in zinc ores	12,500
Resources in copper ores	30,000
Reserves in copper ores	6,300
World total indium resources	125,000
World total indium reserves	18,800

**Table 72: World Indium Reserves<sup>124</sup> (Lokanc, M. et. al., 2015)**

<b>Country</b>	<b>Indium reserves (tonnes of indium)</b>
Canada	180
China	10,400
Peru	480
Russia	80
United States	200
Other <sup>125</sup>	3,700
Total	15,000

#### **EU resources and reserves<sup>126</sup>:**

There is no mineral resource and reserve data for indium reported in the Minerals4EU (2019) project. In Europe, most of the indium mineralisation is located in Variscan units and, to a small extent, in Proterozoic (Sweden), Caledonian and Alpine formations. The largest indium anomalies on the Iberian Peninsula overlap with known metallogenic districts which include deposits such as Neves-Corvo copper-zinc mine in Portugal (Ladenberger, 2015). Since indium is not recovered in all zinc and tin refineries, it is not clear how much indium is produced from the Portuguese ores (Lauri, L. et. al., 2018). Resources of indium were also reported to exist in Austrian lead-zinc deposits, copper deposit in Bulgaria, Czechia, Germany, Greece, Hungary, and Ireland (Lauri, L. et. al., 2018).

#### **13.4.2.2 World and EU indium bearing ore production**

Indium is not concentrated enough to be a major commodity in deposits, but it is recovered as a by-product mainly from residues generated during zinc ore processing. A small amount (5%) is produced as a by-product of lead, tin, and copper production (European

<sup>124</sup> Not included: indium in copper, lead, tin and silver deposits, or in discarded residues, slag, or tailings.

<sup>125</sup> Include Australia, Bolivia, India, Ireland, Kazakhstan, and Mexico

<sup>126</sup> For Europe, there is no complete and harmonised dataset that presents total EU resource and reserve estimates for indium. The Minerals4EU project is the only EU-level repository of some mineral resource and reserve data for indium, but this information does not provide a complete picture for Europe. It includes estimates based on a variety of reporting codes used by different countries, and different types of non-comparable datasets (e.g. historic estimates, inferred reserves figures only, etc.). In addition, translations of Minerals4EU data by application of the CRIRSCO template is not always possible, meaning that not all resource and reserve data for indium the national/regional level is consistent with the United Nations Framework Classification (UNFC) system (Minerals4EU 2019). Many documented resources in Europe are based on historic estimates and are of little current economic interest. Data for these may not always be presentable in accordance with the UNFC system. However a very solid estimation can be done by experts.

Commission, 2017). Approximately 95% of the refined indium produced in the world comes from the processing of zinc ores (Lokanc, M. et. al., 2015).

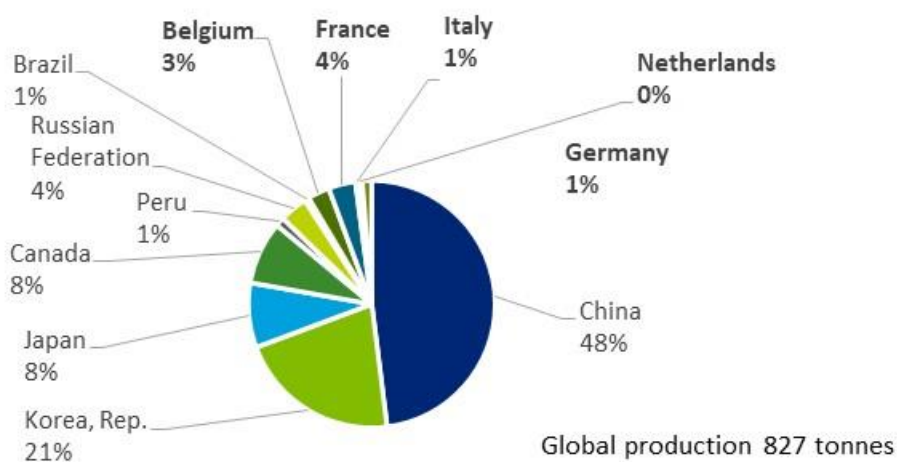
The figures on mine production for indium as byproduct of zinc mining are not publicly available. By assuming that sphalerite ores contain 67% zinc and 15-50 ppm of indium, Roskill estimated that 629 tonnes of indium were mined from zinc ores in 2013. China, Peru, Canada, Australia, and the United States accounted for 79% of potentially recoverable indium from zinc ores in 2013 (Lokanc, M. et. al., 2015). In the EU, Ireland was estimated to have 10 tonnes of potential indium content from mined zinc ores in 2013.

The Neves-Corvo VMS-type Cu-Zn-Sn deposit contains the largest known indium resource in Europe, estimated at 3480 tonnes (Lauri, L. et. al., 2018). The Neves-Corvo mine produces zinc and tin concentrates that, probably, also contain significant amounts of indium. Since indium is not recovered in all zinc and tin refineries, it is not clear how much indium is produced from the Portuguese ores (Lauri, L. et. al., 2018).

### 13.4.2.3 World and EU primary indium refinery production

Indium recovered from mine concentrates requires further refining to reach the desired purity. Most indium producers are not fully integrated; mine producers usually sell indium-bearing concentrates on the open market. Indium from zinc smelting is usually sold as a sponge.

The world refinery production of primary indium was approximately 827 tonnes per year on average over the period 2012-2016. China continued to be the major producer with almost half of the global production (48%). The remaining production was predominantly in South Korea (21% share), Japan (8%), Canada (8%), and Russia (4%) (WMD, 2019).



**Figure 163: Global production of primary indium in tonnes and percentage. Average for the year 2012-2016. (WMD, 2019)**

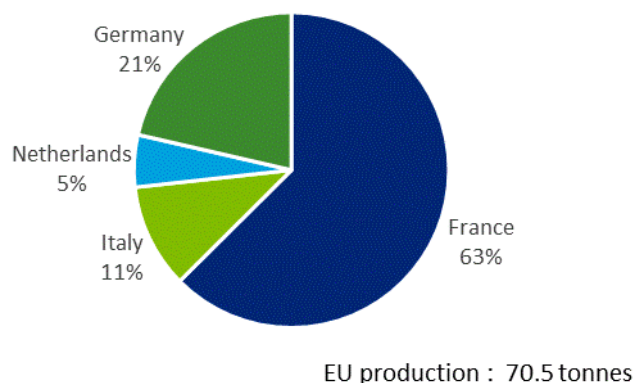
The EU production of refined indium amounted to 70.5 tonnes per year on average on the period 2012-2016 and represented around 8.5% of the world production. The EU production of indium in this period by country is presented in Figure 164. Most primary indium is produced as a by-product of zinc mining and refining. However, the indium content of zinc ores mined in the EU or the zinc ores imported into the EU are not published (Bio by Deloitte, 2015).

Belgium and France refined indium from imported concentrates, residues and slags. In France, Nyrstar commissioned a new virgin indium plant at Aubry in 2012 which produced 43 tonnes of metal in 2014 (European Commission, 2017). Aubry's zinc concentrates were sourced from suppliers world-wide (Nyrstar, 2016). No indium was produced in 2016 due



to a fire incident at the indium cement plant that occurred in late 2015 (USGS, 2016b). The indium plant has since been re-built with additional capacity, bringing total production capacity to 70 tonnes per year. The production has resumed in 2017.

The other major producer was Umicore in Belgium. Umicore produced refined indium at its Hoboken plant from dusts and residues generated by its lead-copper processing plant. Umicore Precious Metals Refining produces a crude  $\text{In}(\text{OH})_3$  (Indiumhydroxide) for further refining. In 2019, they reported a capacity of 50 tonnes of indium contained products per year (Umicore, 2019). However, the exact quantitative data on the production of Belgium (Umicore) is not published.



**Figure 164: EU production of indium percentage. Average for the years 2013-2016. (WMD, 2019)**

Germany's small production which consisted into upgrading 4N indium (99.99 In) to very high purity indium (up to 7N) (PPM Pure Metals) was not included in the EU primary production. In Germany, Saxony Minerals and Exploration AG is working at the Pöhla deposit in Saxony, Germany with the aim of starting tungsten, tin, indium and fluorite production. According to the company, pilotscale production has started in late 2017 (Lauri, L. et. al., 2018).

### 13.4.3 Supply from secondary materials/recycling

Since the indium price increases in 1995 and in 1996, secondary production has been a significant contributor to overall supply (Lokanc, M. et. al., 2015). World secondary refined indium production resulted almost exclusively from the recycling of manufacturing waste (new scrap) rather than recovery from end-of-life (EOL).

#### 13.4.3.1 Pre-consumer recycling (old scrap)

Most of the indium produced in the world is used in ITO (tin-doped indium oxide) thin-film coating on flat-panel liquid-crystal displays. New scrap used in the secondary production of indium consists mainly of spent ITO sputtering targets, which are used as ITO source material to produce thin films. Only 30% of the ITO target material is actually deposited onto the substrate when using planar sputtering targets, which are the dominant form of targets. The thin film production efficiency has been greatly improved by the use of rotary sputtering targets. What is left of the target is recycled into indium metal. It is estimated that over 70% of the indium from the starting targets is recovered (Mikolajczak, 2009). Before 1996, only a little part of the indium in ITO manufacturing waste was recycled. Since then, Japan, South Korea and China, where ITO production and thin film manufacturing take place, have installed significant recycling capacities (Lokanc, M. et. al., 2015). Some producers in Belgium, Canada, and Germany also owned indium recycling capacity to a lesser extent (Lokanc, M. et. al., 2015).

Precise data on the amount of secondary indium recovered from scrap are not available, though are estimated to be similar to the quantity of primary production. NREL estimated the production of refined indium from secondary supply reached 610 tonnes in 2013 (Lokanc, M. et. al., 2015).

Previously, the Indium Corporation (Jackson, 2012) estimated that approximately 1,500 tonnes of refined indium was produced in 2011, including 950 tonnes of recycled indium.

**Table 73: Material flows relevant to the EOL-RIR of indium<sup>127</sup>, reference year 2012 (BioIntelligence, 2015)**

MSA Flow	Value (kg)	Year
B.1.1 Production of primary material as main product in EU sent to processing in EU	0	2012
B.1.2 Production of primary material as by product in EU sent to processing in EU	99,000	2012
C.1.3 Imports to EU of primary material	17,000	2012
C.1.4 Imports to EU of secondary material	8,300	2012
D.1.3 Imports to EU of processed material	61,000	2012
E.1.6 Products at end of life in EU collected for treatment	60,000	2012
F.1.1 Exports from EU of manufactured products at end-of-life	14,000	2012
F.1.2 Imports to EU of manufactured products at end-of-life	3,000	2012
G.1.1 Production of secondary material from post consumer functional recycling in EU sent to processing in EU	200	2012
G.1.2 Production of secondary material from post consumer functional recycling in EU sent to manufacture in EU	0	2012

#### 13.4.3.2 End of life recovery and recycling

Very little old scrap (1%) is recycled worldwide (UNEP, 2011) because of minor indium concentrations in final products, a lack of appropriate technology, or low economic incentives compared to recycling costs (Ylä-Mella and Pongrácz, 2016).

The End-of-life Recycling input rate (Eol-RIR) used in the criticality assessment was set at 0%.

### 13.5 Other considerations

#### 13.5.1 Environmental and health and safety issues

Indium metal is not subject to registration under the EU REACH regulations (ECHA, 2017). Indium tin oxide and indium phosphide are both subject to registration under the EU REACH regulation (ECHA, 2019a) (ECHA, 2019b).

### 13.6 Comparison with previous EU assessments

The criticality assessment 2020 has been conducted using the same methodology and assumptions as for the 2017 list. The results of this and earlier assessments are shown in Table 74.

<sup>127</sup> EOL-RIR=(G.1.1+G.1.2)/(B.1.1+B.1.2+C.1.3+D.1.3+C.1.4+G.1.1+G.1.2)

The economic importance of indium has slightly increased between 2012-2016. Since the end-use application of indium remained the same as in the criticality assessment 2017, this increase was a result of the change in the value added of the sectors for which the end-use of indium was relevant.

As it was done in criticality assessment 2017, the supply risk (SR) score is calculated based on the Global HHI only, which reflects the uncertainty about EU production and trade data.

The supply risk score has decreased in comparison with the result from criticality assessment 2017. The lower supply risk value is closely related to the decreasing production share of China in comparison to the period 2010-2014.

**Table 74: Economic importance and supply risk results for indium in the assessments of 2011, 2014, 2017, 2020 (European Commission, 2011; European Commission, 2014; European Commission, 2017)**

Assessment	2011		2014		2017		2020	
	EI	SR	EI	SR	EI	SR	EI	SR
Indium	6.7	2.0	5.6	1.8	3.1	2.4	3.25	1.79

## 13.7 Data Sources

### 13.7.1 Data sources used in the factsheet

Argusmedia (2019). News – China may auction more indium after Fanya retrial. [online] available at: <https://www.argusmedia.com/en/news/1947283-china-may-auction-more-indium-after-fanya-retrial> published on 26th of July 2019.

Bio by Deloitte (2015) Study on Data for a Raw Material System Analysis Final report [online] available at: [http://cymcdncom/sites/wwwintlomagorg/resource/resmgr/docs/membership\\_central/newsletter/2016/February/MSA\\_Final\\_Report\\_02pdf](http://cymcdncom/sites/wwwintlomagorg/resource/resmgr/docs/membership_central/newsletter/2016/February/MSA_Final_Report_02pdf)

CRM Alliance (2019). Personal communication with Rebecca Lentini after Ad-Hoc-Working-Group meeting in Brussels, June 2019.

DERA Price monitor (2019). [online] Available at: [https://www.deutsche-rohstoffagentur.de/SharedDocs/GT\\_Produkte/Mineral\\_Rohstoffe/volatilitaetsmonitor\\_all-genTab\\_DE.html?nn=5091242](https://www.deutsche-rohstoffagentur.de/SharedDocs/GT_Produkte/Mineral_Rohstoffe/volatilitaetsmonitor_all-genTab_DE.html?nn=5091242)

ECHA (2017). European Chemicals Agency - Registered substances. [online] available at: <https://echa.europa.eu/>

ECHA (2019a). European Chemicals Agency - Regulatory management option analysis: Indium Tin Oxide. [online] Available at: <https://echa.europa.eu/rmoa/-/dislist/details/0b0236e1809b8001>

ECHA (2019b). European Chemicals Agency - Substance information: Indium phosphide. [online] Available at: <https://echa.europa.eu/substance-information/-/substanceinfo/100.040.856>

European Commission (2010). Critical raw materials for the EU. [online] Available at: [https://ec.europa.eu/growth/sectors/raw-materials/specific-interest/critical\\_en](https://ec.europa.eu/growth/sectors/raw-materials/specific-interest/critical_en)

European Commission (2014). Report on Critical Raw Materials for the EU. Non-Critical Raw Materials Profiles [online] Brussels European Commission, Available at: <http://ec.europa.eu/growth/sectors/raw-materials/specific-interest/critical/>

European Commission (2017). Critical raw materials for the EU. [online] Available at: [https://ec.europa.eu/growth/sectors/raw-materials/specific-interest/critical\\_en](https://ec.europa.eu/growth/sectors/raw-materials/specific-interest/critical_en)

- Eurostat (2019)a. International Trade Easy Comext Database [online] Available at: <http://epp.eurostat.ec.europa.eu/newxtweb/>
- Eurostat (2019)b. Annual detailed enterprise statistics for industry (NACE Rev. 2, B-E). [online] Available at: [http://ec.europa.eu/eurostat/en/web/products-datasets/-/SBS\\_NA\\_IND\\_R2](http://ec.europa.eu/eurostat/en/web/products-datasets/-/SBS_NA_IND_R2)
- Indium Corporation (2013). The Indium Market. [online] Available at: <http://www.etf.com/sections/features-and-news/4864-indium-at-your-fingertips-the-go-to-minor-metal-for-flat-panel-displays?nopaging=1>
- Jackson, W (2012) The Future of Indium Supply and ITO Indium Corporation Association of International Metallizers, Coaters and Laminators (AIMCAL) Web Coating and Handling Conference, Myrtle Beach, South Carolina. [online] available at: [http://www.waimcal.org/uploads/4/6/6/9/46695933/jackson\\_prespdf](http://www.waimcal.org/uploads/4/6/6/9/46695933/jackson_prespdf)
- Ladenberger, A., Demetriades, A., Reimann, C., Birke, M., Sadeghi, M., Uhlbäck, J., Zomeni, Z. (2015). GEMAS: Indium in agricultural and grazing land soil of Europe - Its source and geochemical distribution patterns *Journal of Geochemical Exploration*, 154, 61-80. [online] available at: DOI: 101016/jgexplo201411020
- Lauri, Laura (GTK), Teresa Brown, Gus Gunn (BGS), Per Kalvig (GEUS), Henrike Sievers (BGR). (2018). SCRREEN D3.1. Identification and quantification of primary CRM resources in Europe.
- Lokanc, M., Eggert, R. and Redlinger, M. (2015). The Availability of Indium: The Present, Medium Term, and Long Term National Renewable Energy Laboratory (NREL) [online] available at: <http://www.nrel.gov/docs/fy16osti/62409pdf>
- Marketwatch (2019). Press Release: Indium market size share 2019 – global industry analysis. [online] available at <https://www.marketwatch.com/press-release/indium-market-size-share-2019-global-industry-analysis-trends-industry-demand-growth-opportunities-and-forecast-2024-2019-10-18>
- Mikolajczak, C. (2009) "Availability of Indium and Gallium" Indium Corporation of America [online] available at: [www.commodityintelligence.com/images/2010/jan/11%20jan/availability\\_of\\_indium\\_and\\_galliumwhite\\_papermikolajczak\\_sept09pdf](http://www.commodityintelligence.com/images/2010/jan/11%20jan/availability_of_indium_and_galliumwhite_papermikolajczak_sept09pdf)
- Minerals4EU (2019). European Minerals Yearbook. [online] Available at: [http://minerals4eu.brgm-rec.fr/m4eu-yearbook/theme\\_selection.html](http://minerals4eu.brgm-rec.fr/m4eu-yearbook/theme_selection.html)
- Monnet, A., Abderrahim, A.A. (2018). Report on major trends affecting future demand for critical raw materials. SCRREEN D2.2. Available online at: <http://www.screen.eu/wp-content/uploads/2018/07/D2.2-Report-on-major-trends-affecting-future-demand-for-critical-raw-materials.pdf>
- Nyrstar (2015). 2014 Annual Report [online] available at: <http://www.nyrstar.com/investors/en/Pages/reportspresentations.aspx>
- Pinto ,A, Relvas, J.M.R.S., Carvalho, J.R.S., Liu ,Y., Pacheco, N., Pinto, F., Fonseca, R. (2014). High-Tech Metals in the zinc-rich massive ores of the Neves Corvo Deposit *Comunicações Geológicas*, 101, Especial II, pp 825-828.
- Rudnick R, Gao S (2014) Composition of the continental crust. In: Holland H, Turekian K (eds) *Treatise on geochemistry*, 2nd edn. Elsevier, Oxford, pp 1–51
- Schwarz-Schampera, U. (2014) Indium, pp 204–229, *in* Gunn, G (Ed) (2014) *Critical Metals Handbook* John Wiley & Sons Ltd, Chichester, UK, p454.
- SCRREEN workshop. (2019). "Validation Workshop on Critical Raw Materials, 10-12 September 2019, Thon Hotel Brussels City Centre."

- Umicore (2019). Minor metal products – Indium. [online] available at <https://pmr.umicore.com/en/metals-products/minor-metals/> access date: 20-11-2019
- UNEP (2011). Metal Recycling - Opportunities, limits, infrastructure. A Report of the Working Group on the Global Metal Flows to the International Resource Panel. [online] Available at: <http://www.unep.org/resourcepanel/publications/metalrecycling/tabid/106143/default.aspx>
- USGS (2012). Mineral Commodity Summaries. Zinc. [online] Available at: <https://minerals.usgs.gov/minerals/pubs/commodity/zinc/mcs-2012-zinc.pdf>
- USGS (2016a). Mineral Commodity Summaries. Indium. [online] Available at: <https://minerals.usgs.gov/minerals/pubs/commodity/indium/mcs-2016-indiupdf>
- USGS (2016b). Mineral Yearbook. Indium. [online] Available at: <https://prd-wret.s3-us-west-2.amazonaws.com/assets/palladium/production/atoms/files/myb1-2016-indium.pdf>
- USGS (2019). Mineral Commodity Summaries. Indium. [online] Available at: <https://minerals.usgs.gov/minerals/pubs/commodity/indium/mcs-2019-indiupdf>
- Vulcan, T. (2013) Indium at your fingertips, the go-to minor metal for flat-panel displays [online] available at: <http://www.wetfcom/sections/features-and-news/4864-indium-at-your-fingertips-the-go-to-minor-metal-for-flat-panel-displays>
- World Mining Data (WMD) (2019). Bundesministerium für Wissenschaft, Forschung und Wirtschaft. Austrian Federal Ministry of Science, Research and Economy [online] Available at: <http://www.en.bmwfw.gv.at/Energy/WorldMiningData/Seiten/default.aspx>
- Ylä-Mella, J and Pongrácz, E (2016) Drivers and Constraints of Critical Materials Recycling: The Case of Indium Resources 2016, 5, 34 doi:103390/resources5040034

### **13.7.2 Data sources used in the criticality assessment**

The global supply figure from was an average for 2013-2016, since the data was not available before 2013 in World Mining Data.

- Bio by Deloitte (2015) Study on Data for a Raw Material System Analysis Final report [online] available at: [http://cymcdn.com/sites/wwwintlimgorg/resource/resmgr/docs/membership\\_central/newsletter/2016/February/MSA\\_Final\\_Report\\_02.pdf](http://cymcdn.com/sites/wwwintlimgorg/resource/resmgr/docs/membership_central/newsletter/2016/February/MSA_Final_Report_02.pdf)
- European Commission (2016). DG Trade. Agreements [online] Available at: <http://ec.europa.eu/trade/policy/countries-and-regions/agreements/>
- European Commission (2017). Critical raw materials for the EU. [online] Available at: [https://ec.europa.eu/growth/sectors/raw-materials/specific-interest/critical\\_en](https://ec.europa.eu/growth/sectors/raw-materials/specific-interest/critical_en)
- Eurostat (2019)a. International Trade Easy Comext Database [online] Available at: <http://epp.eurostat.ec.europa.eu/newxtweb/>
- Eurostat (2019)b. Annual detailed enterprise statistics for industry (NACE Rev. 2, B-E). [online] Available at: [http://ec.europa.eu/eurostat/en/web/products-datasets/-/SBS\\_NA\\_IND\\_R2](http://ec.europa.eu/eurostat/en/web/products-datasets/-/SBS_NA_IND_R2)
- Indium Corporation (2013). The Indium Market. [online] Available at: <http://www.etf.com/sections/features-and-news/4864-indium-at-your-fingertips-the-go-to-minor-metal-for-flat-panel-displays?nopaging=1>

OECD (2019). Export restrictions on Industrial Raw Materials. [online] Available at: [http://qdd.oecd.org/table.aspx?Subject=ExportRestrictions\\_IndustrialRawMaterials](http://qdd.oecd.org/table.aspx?Subject=ExportRestrictions_IndustrialRawMaterials) [Accessed September 2019]

SCRREEN workshop. (2019). "Validation Workshop on Critical Raw Materials, 10-12 September 2019, Thon Hotel Brussels City Centre."

Tercero Espinoza, L., Hummen, T., Brunot, A., Hovestad, A., Pena Garay, I., Velte, D., Smuk, L., Todorovic, J., van der Eijk, C. and Joce, C. 2013. "Critical Raw Materials Substitution Profiles. September 2013 Revised May 2015. CRM\_InnoNet Available At:" <http://www.criticalrawmaterials.eu/wp-content/uploads/D3.3-Raw-Materials-Profiles-final-submitted-document.pdf>.

UNEP (2011). Metal Recycling - Opportunities, limits, infrastructure. A Report of the Working Group on the Global Metal Flows to the International Resource Panel. [online] Available at: <http://www.unep.org/resourcepanel/publications/metalrecycling/tabid/106143/default.aspx>

USGS (2019). Mineral Commodity Summaries. Indium. [online] Available at: <https://minerals.usgsgov/minerals/pubs/commodity/indium/mcs-2019-indiupdf>

World Mining Data (WMD) (2019). Bundesministerium für Wissenschaft, Forschung und Wirtschaft. Austrian Federal Ministry of Science, Research and Economy [online] Available at: <http://www.en.bmwf.gv.at/Energy/WorldMiningData/Seiten/default.aspx>

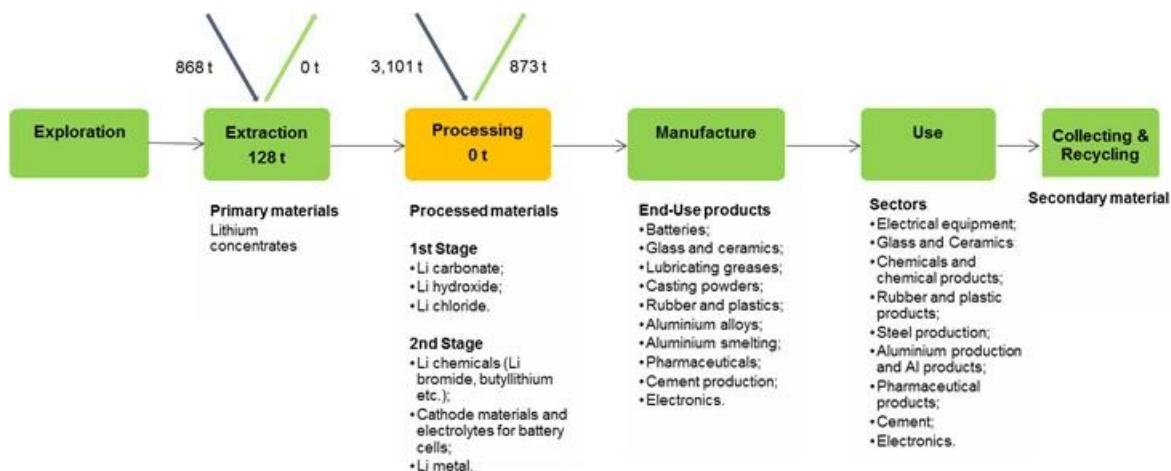
## **13.8 Acknowledgments**

---

This factsheet was prepared by the JRC. The authors would like to thank SCRREEN expert network, the EC Ad Hoc Working Group on Critical Raw Materials and all other relevant stakeholders for their contributions to the preparation of this Factsheet.

# 14 LITHIUM

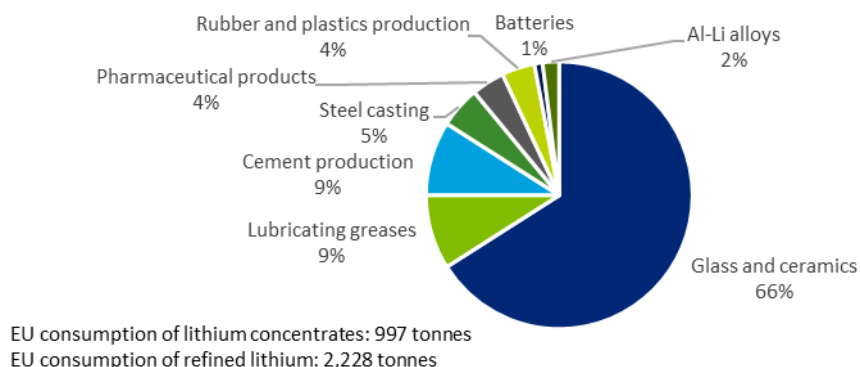
## 14.1 Overview



**Figure 165: Simplified value chain for lithium in the EU<sup>128</sup> (average 2012-2016)**

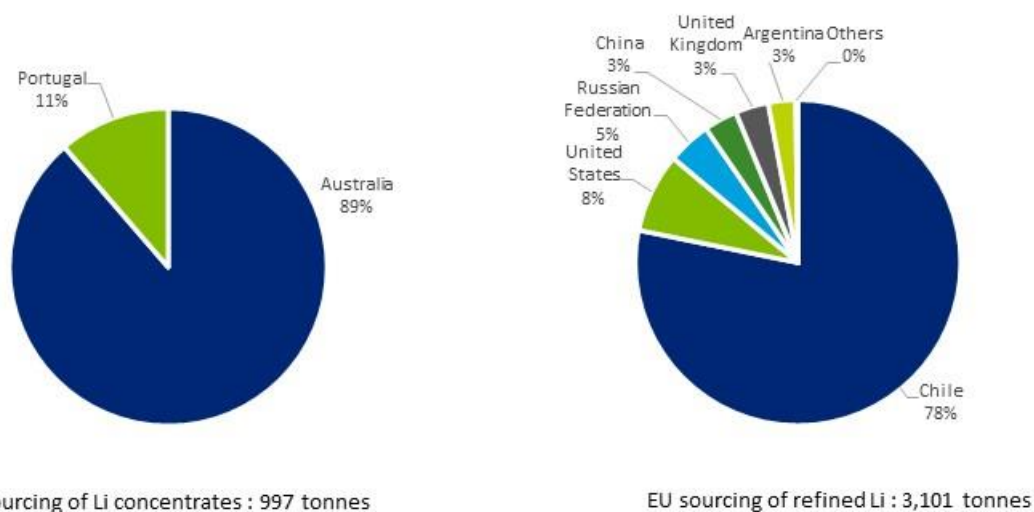
Lithium (chemical symbol Li) is a silver-white to grey metal belonging to the alkali metal group. With a density of only 0.53 g/cm<sup>3</sup>, lithium is the lightest metal and the least dense solid element at room temperature. Also, lithium has excellent electrical conductivity and the highest electrochemical potential of all metals. Due to its high reactivity lithium only occurs in nature in the form of inert mineral compounds such as silicates, or, in general, as chloride in brines and seawater.

In the current criticality assessment, lithium is analysed at both extraction and processing stage. At the mine stage, lithium is assessed in the form of lithium concentrates, whereas, at the processing/refining stage, the lithium compounds considered are lithium carbonate and lithium hydroxide. The trade codes representing the trade of refined lithium are HS 283691 "Lithium carbonates" (Li content 18.8%), and HS 282520 "Lithium oxide and hydroxide" (Li content 16.5% with the assumption that all trade takes place in the form of lithium hydroxide monohydrate). No trade code specific to lithium ores and concentrates is available under the Harmonised System of trade codes, nor for other lithium compounds (e.g. lithium chloride, lithium metal).



**Figure 166: End uses and EU consumption of lithium, in Li content (average 2012-2016) (Eurostat 2019), (WMD, 2019)**

<sup>128</sup> JRC elaboration on multiple sources (see next sections)



**Figure 167: EU sourcing of lithium, in Li content (average 2012-2016) (Eurostat 2019)**

All quantities are expressed in tonnes of contained lithium. Data provided in this factsheet is an average over 2012-2016 unless otherwise stated.

Australia dominates production and exports from hard-rock lithium minerals. Chile holds the largest share of the market for lithium carbonate from brines, with 61% of the total exports of lithium carbonate in 2016. China is the main importer of lithium concentrates, as well as the top importer of lithium carbonates (24% of the world total for lithium carbonates). In 2016, China was also the leading exporter of lithium hydroxide with 37% of total exports, whereas South Korea and Japan were the main destinations for exports of lithium hydroxide (24% each of the world total). China dominates lithium's midstream and downstream segments of the value chain for Li-ion batteries, as it hosts the majority of the global lithium refined production and the three-quarters of the global installed manufacturing capacity for Li-ion batteries. The global value of lithium production is estimated at EUR 1.84 billion in 2016.

The electrification of vehicles and the ramp-up of the related battery production will lead to significantly higher demand for lithium. Lithium supply has to increase to balance the expected demand growth for electric vehicles (EV).

There has been considerable volatility in lithium prices in the period 2015-2019. Lithium prices rose over 250% from 2015 to mid-2018 as a result of the expectations for increased demand for electric vehicle batteries in the future. However, after the period of strong growth, lithium prices have declined remarkably by nearly 40% up to July 2019 driven by oversupply in primary supply from new lithium projects as well as slower demand pickup.

The total EU consumption of lithium is about 3,208 tonnes in lithium content per year on average between 2012 and 2016 (31% lithium concentrates and 69% refined lithium). Imports from Australia cover the majority of the EU demand for lithium concentrates. The import reliance for lithium concentrates is 87%. Moreover, the EU is entirely dependent on imports for its consumption of refined lithium compounds (import reliance of 100%) as there is no domestic refining. Chile is by far the EU's largest supplier (78%) of refined lithium compounds.

Lithium and its compounds have several applications, including batteries, production of glassware and ceramics, manufacture of grease lubricants, polymer production, fluxes for steel and aluminium production, pharmaceutical products. In the EU, the glass and ceramics industry make up 59% of the total consumption. Globally, batteries represent the application with the highest consumption (39% of the total). Substitutes are available



for batteries (zinc for primary, nickel and lead for rechargeable), lubricating greases, glass and ceramics. **There are no substitutes foreseen in the short to mid-term that can replace the role of lithium in rechargeable batteries for electric vehicles and energy storage systems.**

**Lithium is currently extracted from two distinct sources, hard-rock deposits and continental brines.** Brine resources are mostly found in South American countries – Chile, Argentina and Bolivia – in an area known as the “Lithium Triangle”, which contains half of the world’s lithium resources and 70% of global reserves. **Australia hosts the world’s most abundant hard-rock minerals resources.** Global reserves of lithium are on the order of 14 million tonnes of contained lithium. In the EU, important hard-rock mineral deposits are located in Portugal, Czechia, Finland, Germany, Spain, and Austria. Significant brine resources exist in Germany.

The world annual production of lithium minerals is about 32,386 tonnes of Li content (averaged over 2012-2016). 37% of this is produced in Chile and 32% in Australia. In 2015, Chile was the leading producer of processed Li compounds (44%), followed by China (39%) and Argentina (13%). EU domestic production of lithium concentrates is insignificant compared to global production, at about 110 tonnes of lithium content. The production of processed lithium compounds in the EU is also negligible, and it is assumed as zero in this factsheet.

Even though lithium-ion batteries are recycled in the EU, **industrial-scale recycling of lithium is not considered economically viable.** Lithium, a critical raw material for lithium-ion batteries, is an essential raw material for the implementation of the EU long-term strategy for a climate-neutral economy by 2050 as it is used in manufacturing of rechargeable batteries for electric vehicles and energy storage systems.

## **14.2 Market analysis, trade and prices**

---

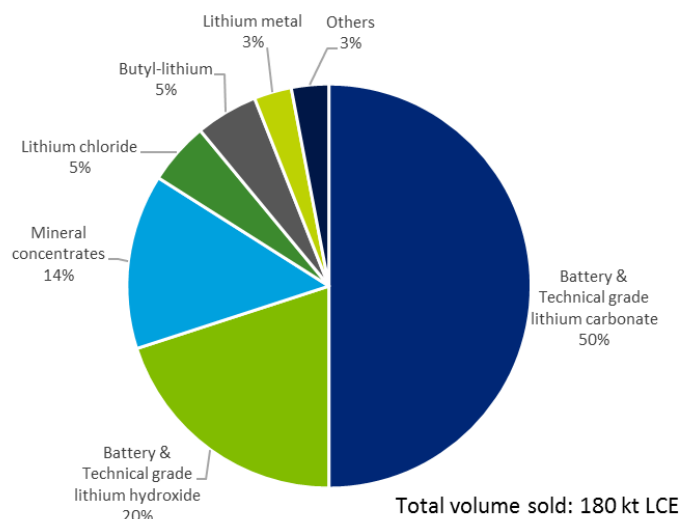
### **14.2.1 Global market**

Global lithium production was relatively flat from the late 1950s through to the early 1980s at levels of about 5,000 tonnes annually of lithium content (BGS 2016). Since then it has increased by more than six times. In the last years in particular, world lithium mineral production rose from about 120 kt lithium carbonate equivalent (LCE) (or 22.5 kt of Li) in 2007, to 194 kt LCE (or 36.5 kt of Li) in 2016 at a compound annual growth rate (CAGR) of 5% per year. This is one of the highest CAGR observed for any mineral and metal (background data in (WMD 2019)). The rapidly growing demand for lithium is driven by a strong growth rate in the demand for Li-ion batteries (Christmann et al. 2015). The value of world annual production was estimated at EUR 1.84 billion<sup>129</sup> in 2016.

Lithium is marketed in the form of various products depending on the end-use. According to Hocking (Hocking et al. 2016), lithium compounds accounted for 86% of the global lithium market in 2015. The remaining 14% are mineral concentrates marketed directly without further processing. Lithium carbonate represents the most common lithium commodity in the market, accounting for approximately 50% (see Figure 168).

---

<sup>129</sup> Estimated with an average price of lithium carbonate of EUR 9,448 per tonne (2016)



**Figure 168: World lithium market by volume of products sold in 2015 (Hocking et al. 2016)**

Lithium is currently produced from either hard-rock mineral deposits or brines. While in the past lithium was produced exclusively from hard-rock lithium silicate minerals, the lower production costs from lithium-rich brines made the latter increasing its share for lithium production since the early 1980s (BGS 2016) (Hocking et al. 2016). In 2017 and 2018, there has been a sharp increase in supply from hard-rock mining, due to a massive ramp-up of lithium production in Australia. In 2018, hard-rock lithium supply surpassed that from brines, with a share of approximately 55% of the world lithium supply (background data from (S&P Global Market Intelligence 2019a)).

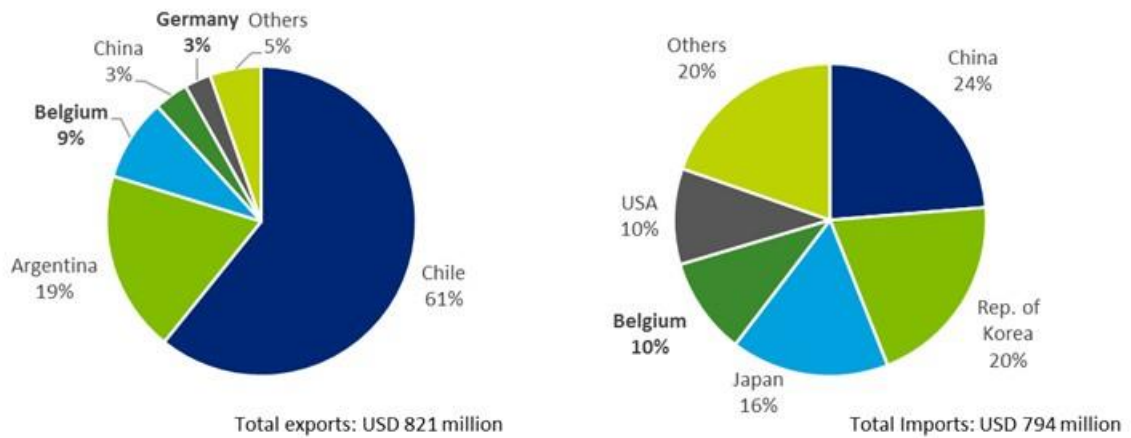
Australia is, by far, the leading producer of lithium mineral concentrate (spodumene), and most of the spodumene produced is exported for processing, mainly to China (USGS 2018) (BGS 2016). However, the quantities involved are not reported by the usual sources of trade statistics as a specific trade code is missing.

China has the majority of the world's refining capacity, and as a result, it is also the world's largest importer, exporter and consumer of lithium. China produces large quantities of lithium carbonate and lithium hydroxide, mainly from mineral concentrates (spodumene), which are mostly imported from Australia (USGS 2018) (Hocking et al. 2016) (CRU 2019). Chile is the world's leading producer of lithium compounds from brines, followed by Argentina.

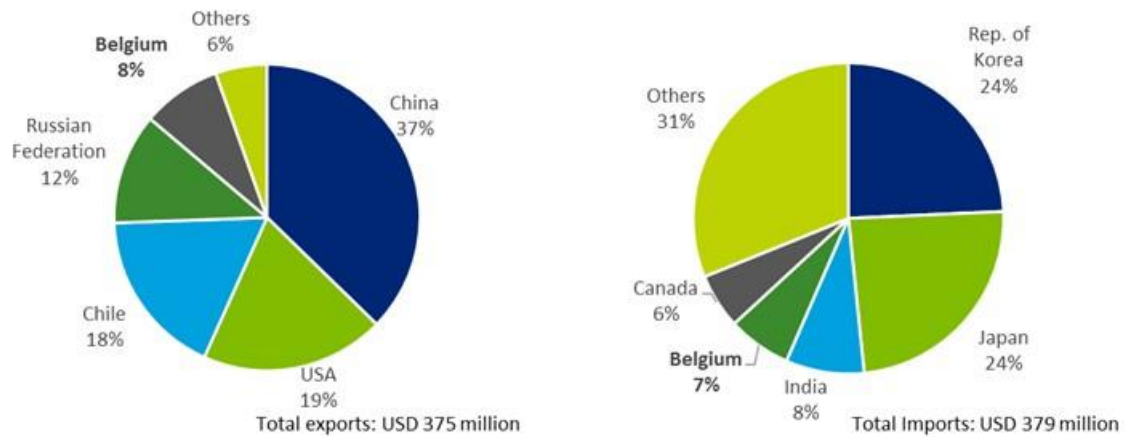
Chile exported about 65 kt tonnes of lithium carbonate in 2016 capturing the highest share of the export market of lithium carbonate in that year with a share of 61% by value of lithium carbonate exports, and this compares to just 19% from the second-largest exporter (Argentina). Countries in Asia are the leading importers, i.e. China (24%), South Korea (20%) and Japan (16%). The total exports of lithium carbonates in 2016 amounted to 109 kt with a total value of USD 821 million.

China was the largest exporter of lithium oxides and hydroxides in 2016, which amounted to almost 10 kt, or 37% of the total value of exports of lithium oxides and hydroxides. Significant exporters of oxides and hydroxides were also the US (19%) and Chile (18%). South Korea and Japan are among the top importers again with 24% each of the total value of imports. The total exports of lithium oxides and hydroxides in 2016 totalled to about 35 kt with a total value of USD 375 million.

A high amount of global trade of refined lithium compounds and lithium batteries is taking place through Belgium.



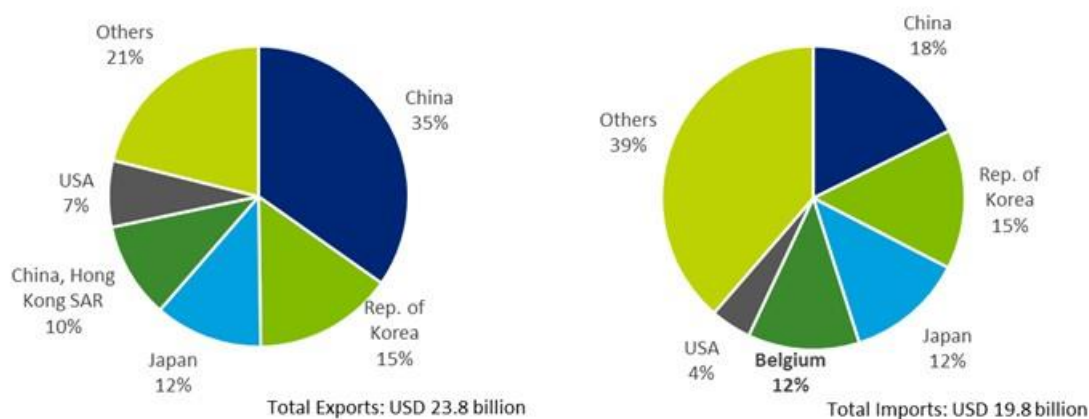
**Figure 169: Top-5 exporters (left) and importers (right) of lithium carbonate (HS 283691) in 2016 by value. Data from (UN Comtrade 2019)**



**Figure 170: Top-5 exporters (left) and importers (right) of lithium hydroxide (HS 282520) in 2016 by value. Data from (UN Comtrade 2019)**

It is important to note that Asian countries dominate the world trade in primary and rechargeable lithium batteries (see Figure 171).

In 2015, about 85% of the world's Li-ion battery cell manufacturing capacity was installed in Asia due to longstanding investments made by consumer electronics companies and governments. China accounted for 50% of the commissioned capacity, whereas the Republic of Korea and Japan for 20% and 15% respectively (USGS 2018). In 2018, the installed global Li-ion battery manufacturing capacity rose to 334 GWh from 65 GWh in 2015, with China having a share of 74% of the total, followed by the US (9%), Japan (8%) and South Korea (4%). The EU-28 holds a limited share of 3.2% (Roskill 2019).



**Figure 171: Top-5 importers (left) and exporters (right) of primary and rechargeable lithium batteries in 2016 by value (HS 850650 + HS 850760). Data from (UN Comtrade 2019)**

Argentina removed an export tax of 5% imposed on lithium oxides and hydroxides and lithium carbonates at the end of 2015, a lift which was reconfirmed at the end of 2017 (OECD 2019). However, the Government of Argentina announced the re-establishment of export duties in September 2018 on all tariff lines which will be in force until the end of 2020. The new export duties consist of a 12% increase with respect to the previously established export duty, but the maximum amount of tax to be paid is limited of USD 0.076 per USD of the FOB value entitled to the tax. The new export tax is applicable to lithium carbonates (HS 283691) (Global Trade Alert 2018).

#### 14.2.2 Outlook for supply and demand

Lithium is one of the vital raw materials for the production of the batteries used in electric vehicles (EV). Therefore, the envisioned substantial growth of the market for electric vehicles should lead to a high increase in lithium demand. According to (Hocking et al. 2016), modest growth is expected in other lithium applications.

Various estimates are published on the outlook of lithium demand. They are based on different scenarios on the global deployment of electric vehicles, the vehicle types (e.g. plug-in hybrid electric vehicles (PHEVs), battery electric vehicles (BEVs)), the evolution of the market growth for EVs, and the mix of battery chemistries. For example, according to Hocking (Hocking et al. 2016) global lithium demand will increase to 535 kt LCE by 2025 (or 100 kt of Li), with batteries accounting for 70% of global demand (375 kt LCE or 70 kt of Li), of which EV batteries alone will utilise 200 kt of LCE (38 kt of Li). According to (Roskill 2019), the lithium demand for batteries in 2028 is forecasted to be 1,130 kt of LCE (or around 200 kt of Li).

The outlook report published by the International Energy Agency (IEA) in May 2019 shows that the global electric car fleet is increasing at a rapid rate. In 2018 it exceeded 5.1 million, 2 million more than in 2017 (Bunsen et al. 2019). IEA estimates the lithium amount used in batteries for EVs sold in 2018 to be about 11 kt. In a scenario based on the announced policy ambitions<sup>130</sup>, the IEA estimates the world annual demand for lithium to increase to around 155 kt by 2030. In a scenario with higher EV uptake<sup>131</sup> the annual world demand for lithium in 2030 will be more than twice as high, i.e. exceeding 300 kt.

<sup>130</sup> Global EV sales reach 23 million and the stock exceeds 130 million vehicles in 2030.

<sup>131</sup> Scenario under the assumption that EVs will reach a 30% market share for all modes except two-wheelers by 2030. EV sales and stock nearly double by 2030 reaching 43 million and more than 250 million respectively.

These estimates of future demand for lithium for EV'S are three to six times higher than the current (2017) world production of lithium of about 50 kt (WMD 2019).

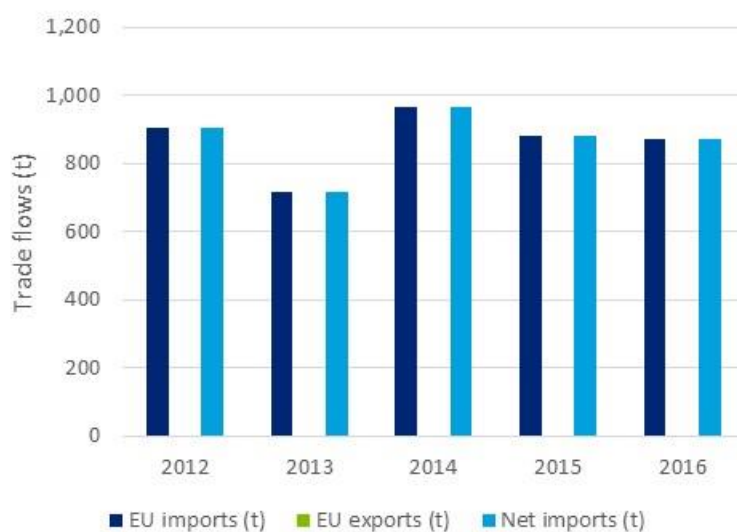
The comparison of the projected lithium demand with the current levels of supply (36.5 kt of Li in 2016) suggests that in the years ahead the supply of lithium has to expand substantially to cover the demand from all end-use sectors, as well as to avoid shortages that may hinder the projected transition to electric mobility. Significant expansions in production capacity have been already announced for the coming years or commissioned recently, and the world output is expected to rise strongly in short to medium term (USGS 2018)(M Schmidt 2017). However, the future availability of lithium depends on many factors which will determine the demand/supply balance such as the prevailing prices, the discovery rate of economically exploitable deposits and investments made in their development, the progress in lithium recycling and battery design, substitution by solid-state batteries etc. (Christmann et al. 2015).

**Table 75: Qualitative forecast of supply and demand for lithium**

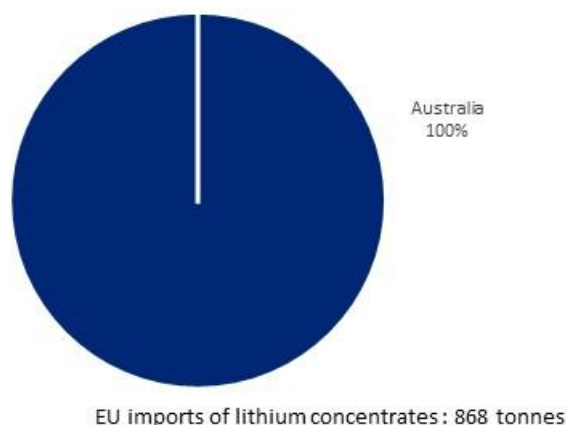
Materials	Criticality of the material in 2020		Demand forecast			Supply forecast		
	Yes	No	5 years	10 years	20 years	5 years	10 years	20 years
Lithium	X		+	+	+	+	+	?

### 14.2.3 EU trade

It is difficult to obtain data for the trade of lithium-containing minerals due to the aggregation of trade statistics and the lack of a specific trade code for lithium ores and concentrates. The EU imports of lithium concentrates are estimated at 868 tonnes of Li content on an annual basis over 2012-2016. The data refers to exports of spodumene concentrates from Australia to the EU, assuming a 5% Li<sub>2</sub>O content. It is also assumed that Australia is the only sourcing country of EU imports of lithium ores and concentrates. Because lithium minerals currently extracted and imported in the EU are used directly in glass and ceramics production, it is reasonable to consider that no export of ores and concentrates of lithium is taking place from the EU.

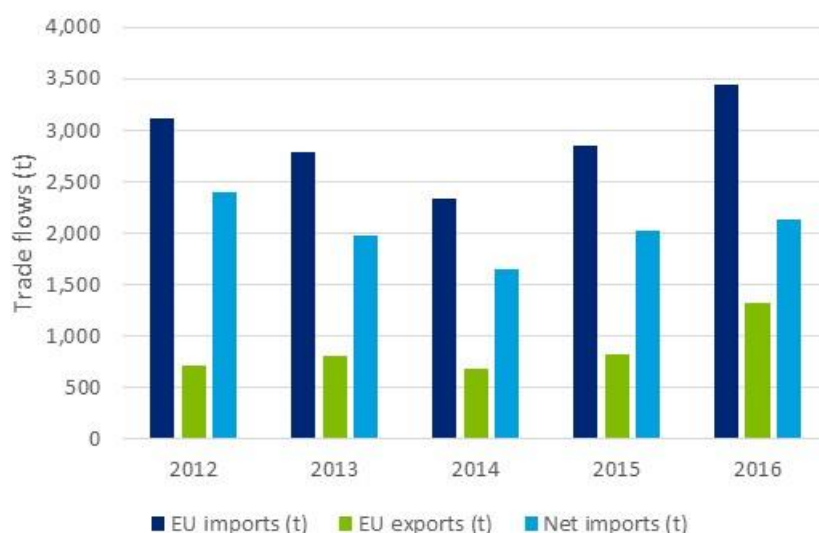


**Figure 172: EU trade flows for lithium ores and concentrates. Data from (CRM validation workshop 2019)**

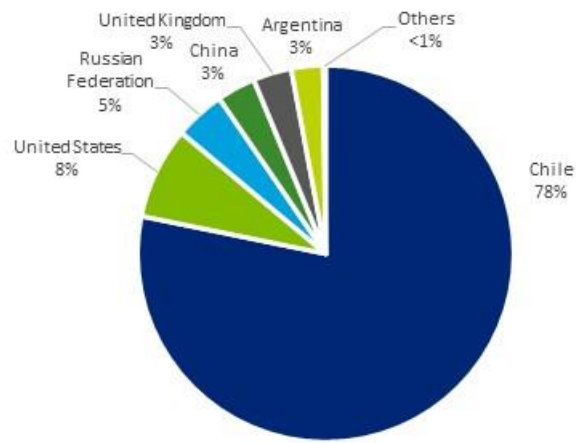


**Figure 173: EU imports of lithium ores and concentrates. Data from (CRM validation workshop 2019)**

On average, between 2012 and 2016, the EU imports of processed lithium compounds are estimated at 3,100 tonnes of lithium contained in processed/refined materials. According to (ESTAT Comext 2019), the EU imports of processed lithium compounds consist annually of about 135 kt of lithium carbonates (HS 283691) and 30 kt of lithium oxides and hydroxides (HS 282520) in gross weight. Lithium carbonate accounts for 83% of the total EU imports of refined lithium compounds in Li content, and lithium hydroxide accounts for the remaining 17% of total imports. The largest share by far (78%) of imports came from Chile, and 8% from the US (ESTAT Comext 2019). Imports of lithium carbonate and lithium hydroxide decreased in 2014 by 25% compared to those of 2012 but increased from 2014 to 2016 by 47%. The EU import reliance is 100%.



**Figure 174: EU trade flows for refined lithium compounds (lithium carbonate and lithium hydroxide). Data from (ESTAT Comext 2019)**



EU imports of refined lithium : 3,101 tonnes

**Figure 175: EU imports of refined lithium compounds. Data from (ESTAT Comext 2019)**

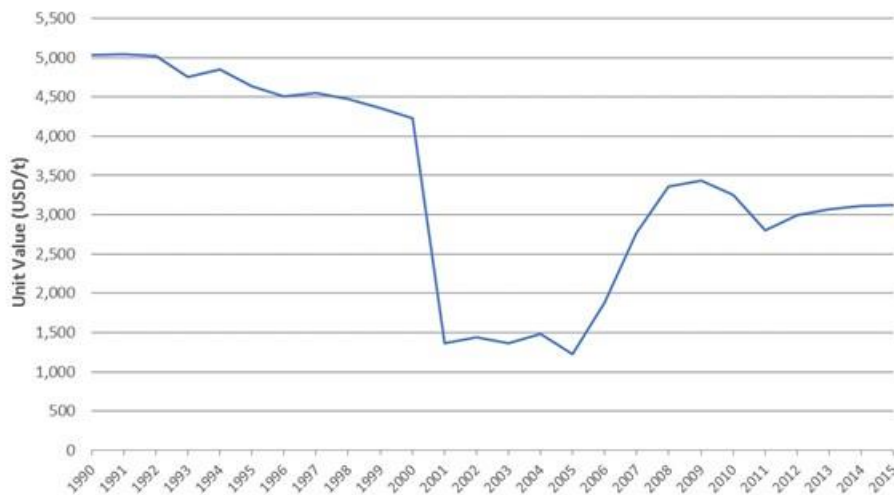
A trade agreement is in force since 2005 with Chile, the dominant producer of lithium worldwide. In addition, the EU and the four members of Mercosur (Argentina, Brazil, Paraguay and Uruguay) have reached on June 28th a political agreement for a trade agreement (European Commission 2019a); Argentina is the world's second exporter of lithium carbonates (see Figure 169) and within the top-5 producing countries worldwide (see Figure 183).

#### 14.2.4 Prices and price volatility

Lithium is traded in many forms, including lithium spodumene concentrate, lithium carbonate technical-grade and battery-grade, lithium hydroxide and others. Each type is priced differently depending on product quality and specifications required (e.g. lithium content, purity) (BGS 2016), (BRGM 2012), (M Schmidt 2017). For example, according to data from S&P (S&P Global Market Intelligence 2019b), battery-grade lithium carbonate was priced 13% higher than technical-grade lithium carbonate in the period January 2018 to July 2019.

Lithium commodities are not traded in international exchange markets, and prices are established through direct negotiations between primary producers and processors or users (M Schmidt 2017). Lithium prices are mainly negotiated in long-term contracts; smaller quantities are traded on spot markets where spot prices can vary significantly and be more volatile from prices in long-term contracts (DERA 2018)(M Schmidt 2017)(BGS 2016). Prices for various products are not available to the general public (BGS 2016) (BRGM 2012).

The long-term trend of lithium prices can be approximated by the US unit value of apparent consumption (Figure 176). Lithium prices followed a moderate downward trend in the 1990s from about USD 5,000 to USD 4,200 per tonne. In 2001 prices dropped considerably to around USD 1,500 per tonne and remained stable until 2005, due to rising supply from South American brines and the general depreciation in the prices of raw materials in the period 2002-2003 (BRGM 2017). From 2006 to 2009, lithium prices recovered as a result of increased demand from China and for Li-ion batteries in portable electronic devices (BRGM 2017). Not surprisingly, prices declined in 2009 due to the reduced demand caused by the global economic recession towards the end of 2008 (BGS 2016). However, they did subsequently recover and remained stable from 2012 to 2014.

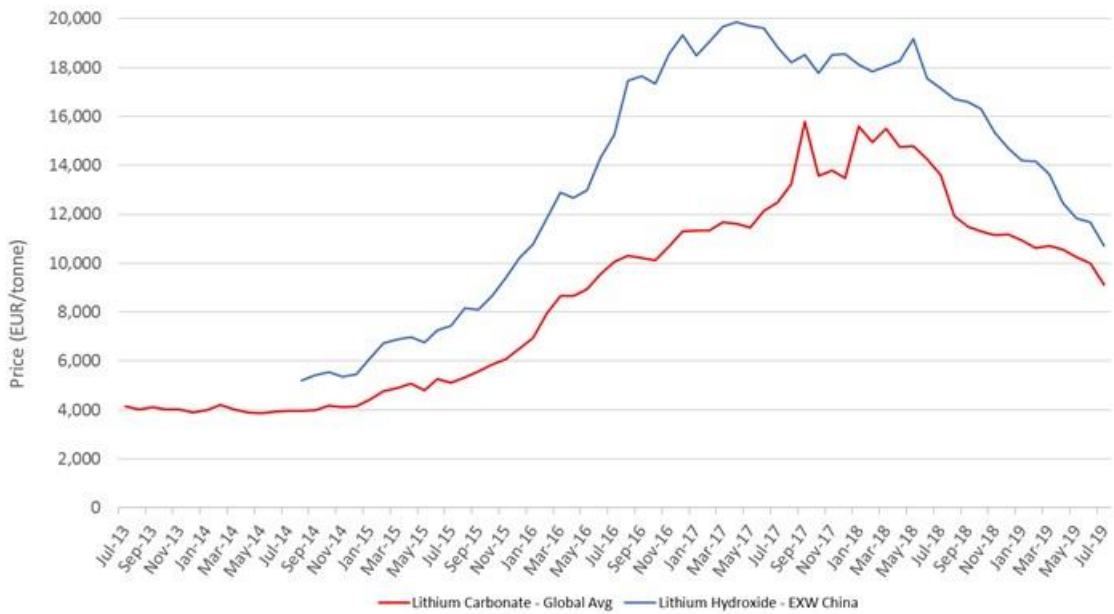


**Figure 176. Trends in lithium pricing in the United States (indexed to the 1998 unit value<sup>132</sup>), yearly average (in USD/tonne of lithium). Data from (USGS 2017)**

Lithium prices rose significantly from the mid-2015 onwards, reflecting the very dynamic market developments in electromobility and industry's expectations for a sharp rise for demand in the future. Consequently, prices on the lithium market nearly increased four times within three years, reaching historical peaks (DERA 2017), (DERA 2018). In particular, the global average price of lithium carbonate was around EUR 4,150 per tonne (USD 5,170/tonne) at the end of 2014, and it rose by 270% to EUR 15,500 per tonne (USD 18,900/tonne) in March 2018. The increase in prices has been more acute in China, as the result of a temporary shortage of imported mineral concentrates from Australia (USGS 2018). However, since the beginning of 2018, a steady downward trend for lithium prices is observed (Figure 177). The global average price of lithium carbonate has dropped by 42% to EUR 9,115 (USD 10,313/tonne) per tonne in July 2019 in comparison to March 2018. The trend for lithium hydroxide, which is priced at a premium in comparison to lithium carbonate, has been similar (see Figure 177). The price of lithium hydroxide in China reached USD 23,000 per tonne in May 2018, whereas in July 2019 almost halved to USD 12,125 per tonne. According to market experts, the decline of lithium prices is the result of the ongoing influx of lithium supply from new projects into the market, led by Australia, combined with weaker than expected demand in China for BEVs, the world's top electric vehicle market (CRU 2019), (Fastmarkets MB 2019).

<sup>132</sup> The unit value in the US is defined as the estimated value of apparent consumption of one tonne of lithium





**Figure 177: Lithium carbonate (global average) and lithium hydroxide monthly price trend (CIF Europe) (EUR/tonne). Data from (S&P Global Market Intelligence 2019b)**

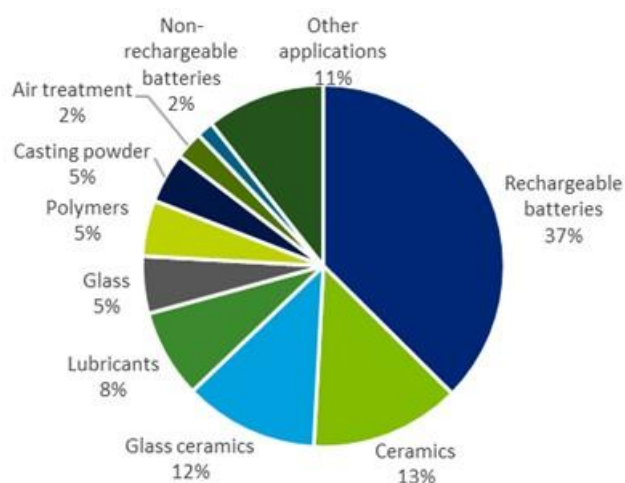
## 14.3 EU demand

### 14.3.1 EU consumption

The EU consumed annually about 3,225 tonnes of lithium in various end-uses on average over 2012-2016. The EU apparent consumption is estimated at approximately 997 tonnes of Li content for lithium concentrates, and 2,228 tonnes of lithium content for refined lithium compounds. The net import reliance as a percentage of apparent consumption is calculated at 87% for lithium concentrates and 100% for refined lithium.

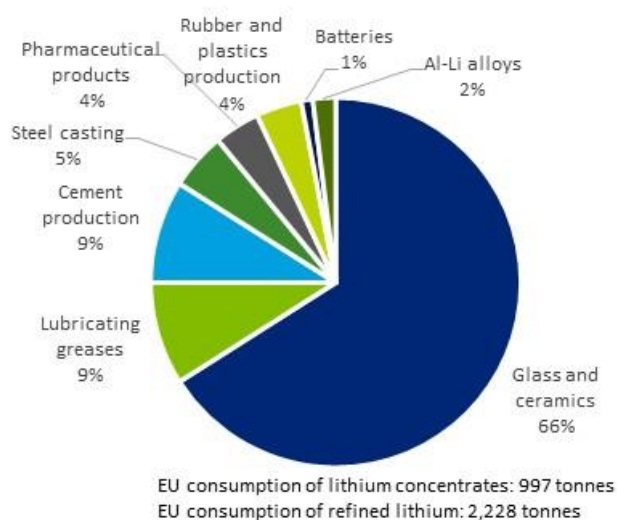
### 14.3.2 Uses and end-uses of lithium in the EU

Lithium's unique properties have resulted in many and diversified commercial applications. In 2015, the manufacture of rechargeable batteries was the main application of lithium accounting for 37% of global lithium demand. Other global markets for lithium products were ceramics, 13%; glass ceramics, 12%; lubricants, 8%; glass, 5%; polymer production, 5%; continuous casting fluxes, 5%; air treatment, 2%; non-rechargeable batteries 2%; and other uses, 11% (BGR 2017).



**Figure 178: Global end uses of lithium in 2015. Data from Roskill (BGR 2017)**

Contrary to the global context, the most significant demand market for lithium in the EU is the glass and ceramics industries, making up 66% of total demand in 2012 (BIO Intelligence Service 2015). The EU production of Li-ion batteries was limited (Patrícia Alves Dias et al. 2018), (Roskill 2019). The shares of lithium use in the EU are provided in Figure 179.



**Figure 179: Lithium uses in the EU<sup>133</sup> in 2012 (BIO Intelligence Service 2015), and EU consumption of lithium (average 2012-2016).**

The relevant industry sectors are described using the NACE sector codes in Table 76.

<sup>133</sup> Finished products manufactured in the EU and other uses of Li in the EU manufacturing industry

**Table 76: Lithium applications, 2-digit and examples of associated 4-digit NACE sectors, and value-added per sector, average between 2012 to 2016 (Eurostat 2019)**

<b>Applications</b>	<b>2-digit NACE sector</b>	<b>Value added of NACE 2 sector (millions €)</b>	<b>Examples of 4-digit NACE sectors</b>
Glass and ceramics	C23 - Manufacture of other non-metallic mineral products	57,255	C2311-Manufacture of flat glass; C2312-Shaping and processing of flat glass; C2313-Manufacture of hollow glass; C2319-Manufacture and processing of other glass, including technical glassware; C2340- Manufacture of other porcelain and ceramic products
Lubricating greases	C20 - Manufacture of chemicals and chemical products	105,514	C2059 - Manufacture of other chemical products n.e.c.
Cement production	C23 - Manufacture of other non-metallic mineral products	57,255	C2351- Manufacture of cement; C2369- Manufacture of other articles of concrete, plaster and cement
Steel casting	C24 - Manufacture of basic metals	55,426	C2410 Manufacture of basic iron and steel and of ferro-alloys C2452- Casting of steel
Pharmaceutical products	C21 - Manufacture of basic pharmaceutical products and pharmaceutical preparations	80,180	C2110 Manufacture of basic pharmaceutical products; C2120 Manufacture of pharmaceutical preparations
Rubber and plastics production	C22 - Manufacture of rubber and plastic products	75,980	C2219- Manufacture of other rubber products
Batteries and products containing batteries	C27 - Manufacture of electrical equipment	80,745	C2720- Manufacture of batteries and accumulators
Al-Li alloys	C25 - Manufacture of fabricated metal products, except machinery and equipment	148,351	C2599 - Manufacture of other fabricated metal products n.e.c.

The diverse applications of lithium can be divided into two broad categories, i.e. technical and chemical.

#### **14.3.2.1 Technical applications**

Technical-grade concentrates are used, with spodumene concentrates as the dominant input; lepidolite and petalite concentrates are used in lower quantities. Lithium carbonate is preferred when quality and other factors exclude the use of mineral concentrates. The technical applications of lithium are grouped in two categories categories:

- *Glass and Ceramics.* In glassmaking, a small amount of lithium oxide (Li<sub>2</sub>O) added as a flux to glass melts reduces melting temperature (usually by as much as 25 °C) and lowers viscosity, which results in production cost savings as energy use is reduced by 5-

10% (Christmann et al. 2015). Besides, glassware containing lithium is characterised by low thermal expansion and increased hardness. Glasses treated with lithium in the form of lithium concentrates which contain silica and alumina – important in many glass formulations – and low  $\text{Fe}_2\text{O}_3$  content on avoiding undesirable discolouration in the products, contain between 0.1 and 0.7%  $\text{Li}_2\text{O}$  (M Schmidt 2017). In alumina-silicate glass ceramics, lithia addition to the formulation to approximately 3-5%  $\text{Li}_2\text{O}$  (M Schmidt 2017) produces a hardened product with nearly zero thermal expansion, able to withstand high temperatures and thermal shocks from sudden temperature changes. Applications include cookware, induction cooktops, safety glasses, fireplace windows, laboratory equipment, telescoping lenses etc. In the ceramics industry, lithium is added as a fluxing agent, in the form of concentrated ore or lithium carbonate, in concentrations from 0.15% up to 2.5% (M Schmidt 2017), to reduce baking temperature and time and improve finishing characteristics and thermal shock resistance of porcelain enamels and glazes, as well as to produce tiles with increased mechanical strength and low thermal expansion.

- *Casting powders.* Lithium in either carbonate or mineral form is used as an additive in mold flux powders for the continuous casting of steel, which is applied in 90% of global crude steel production, ensuring improved molten steel flow without casting defects.

### 14.3.2.2 Chemical applications

A wide variety of lithium-containing products is commercially available. Their uses are listed below (BGS 2016), (M Schmidt 2017), (Hocking et al. 2016), (BRGM 2012):

- *Batteries.* Lithium is one of the most attractive materials for batteries due to its high electrochemical potential combined with the lowest mass. Lithium carbonate and lithium hydroxide are the principal lithium compounds for the production of cathode materials.

In non-rechargeable (or primary batteries) batteries, metallic lithium is used for the anode. These batteries are more expensive than most of other types of disposable batteries like alkaline batteries but are superior concerning operational lifetime, size, stability and durability. Primary lithium batteries are employed in various household applications (e.g. calculators, cameras and watches) and medical devices (e.g. heart pacemakers).

In rechargeable batteries, lithium is present in the electrolyte and the cathode of lithium-ion rechargeable batteries. The advantages of lithium-ion batteries compared to other battery types are outstanding energy and power density as well as long lifetime and cycle life. In the electrolyte, lithium salts (e.g. lithium-perchlorate ( $\text{LiClO}_4$ )) are used together with organic solvents. In the cathode, several lithium-ion chemistries are currently in commercial use with a wide performance range and cost. The prevailing cathode compositions are NMC (lithium-nickel-manganese-cobalt oxide), LCO (lithium-cobalt oxide), LFP (lithium-iron phosphate), LMO (lithium-manganese oxide) and NCA (lithium-nickel-cobalt-aluminium oxide).

Li-ion batteries are applied in a range of end-uses, while new applications still emerge. The largest market has been portable electronic devices such as mobile phones, laptops, tablets, digital cameras, etc., corresponding to 65% of total Li demand for batteries (M Schmidt 2017). Beyond consumer electronics, lithium-ion chemistry has become firmly established as the reference for the emerging electric vehicle (EV) sector, in particular for full-battery electric vehicles (BEVs) and plug-in hybrid electric vehicles (PHEVs). In 2015, electric mobility accounted for almost 31% of total Li use in batteries (M Schmidt 2017). Furthermore, Li-ion batteries have found use in cordless heavy-duty power tools and medical devices (e.g. hearing aids). Finally, Li-ion batteries have the potential to be utilised in off-grid and grid-connected energy storage systems.

- *Lubricating greases.* Lithium is an additive to multi-purpose, high-performance lubricants. Lithium hydroxide monohydrate or lithium carbonate is mixed and heated with fatty acids to produce “lithium soap” grease, a thickening agent which is combined within the lubricant’s final formulation to ensure that lubrication properties are maintained over a wide range of temperatures and extreme load conditions. Lithium grease is one of the most commonly used types of lubricating grease due to its cost-efficiency, excellent water

resistance and effectiveness over a wide temperature range. Lithium grease usually accounts for 6-15% of the final product; approximately 70% of all industrial lubricants produced globally contain lithium, typically at concentrations of 0.2 to 0.3% (Hocking et al. 2016).

- *Pharmaceutical products.* Some lithium-based compounds, including lithium carbonates, are used as antidepressants and mood stabilisers in the treatment of specific psychiatric disorders such as bipolar disorder, depression and other nervous problems. As lithium is being ingested, purity is essential.

- *Primary aluminium production.* Lithium carbonate or lithium bromide addition to the cryolite bath during aluminium smelting reduces the melting point, thus with benefits in energy consumption, carbon cathode degradation and fluorine emissions.

- *Aluminium alloys.* Metallic lithium is alloyed with aluminium to produce lightweight Al-Li and Al-Cu-Li alloys for the manufacture of specific parts in the aerospace industry where a combination of lightweight and high strength is required.

- *Polymer production.* Organolithium compounds such as butyl-lithium serve as catalysts or initiators for the manufacture of synthetic rubber products (e.g. styrene-butadiene, polybutadiene), commonly used in the manufacture of car tyres.

- *Air treatment.* Lithium bromide and lithium chloride are among the best available hygroscopic substances for absorbing water; as a result, these salts found use as a desiccant to dehumidify the moist air, for example in large-scale air conditioning or air drying systems. Also, lithium hydroxide and lithium peroxide are used in scrubbers in enclosed environments (i.e. mining, space and submarine applications) to remove CO<sub>2</sub> from the air.

- *Other applications.* Lithium and other lithium-based compounds are present in smaller quantities in a broad range of minor applications such as:

- *Electronics.* Lithium niobate is used in optics and telecommunications;
- *Nuclear.* The <sup>6</sup>Li and <sup>7</sup>Li isotopes have applications in nuclear weapons and nuclear reactors;
- *Textiles.* Lithium acetate and lithium hydroxide are additives in textile dyeing;
- *Cement.* Lithium carbonate accelerates the hardening process of quick setting alumina cement;
- *Fireworks.* Lithium nitrate generates a red colour in fireworks;
- *Rockets.* Lithium metal and lithium hydrides are employed as high-energy additives in rocket propulsion;
- *Water treatment.* Lithium hypochlorite is used in swimming pool cleaning products;
- *Welding.* Lithium chloride is used as a flux in welding or soldering.

### 14.3.3 Substitution

Substitution for lithium compounds is possible in many applications such as batteries, glass and ceramics, and greases (USGS 2019). However, there is often little incentive to use the available substitutes instead of lithium because of the relatively low lithium's price and the stability of its supply (BGS 2016).

In rechargeable batteries, a wide range of non-lithium types are available on the market, such as nickel-cadmium (NiCd), nickel-metal hydride (NiMH) and lead-acid batteries, with different advantages and disadvantages compared to lithium-ion types. **Generally, the Li-ion battery is progressively replacing nickel batteries due to its better performance, particularly where a high-energy density and lightweight is required (Evans 2014). Lithium has become the preferred material for portable equipment and electric vehicle batteries (BRGM 2012),** (Evans 2014). Nickel-metal hydride (NiMH) batteries compete with Li-ion batteries with good performance for energy storage and hybrid electric vehicles (HEV) (Tercero et al. 2015), (Graedel et al. 2015b). However, lithium batteries are more and more replacing such nickel batteries and most HEVs marketed today use Li-ion batteries (Harvey 2018), (ProSum 2019). There are no substitutes foreseen in the short to mid-term that can replace the role of lithium in rechargeable batteries for electric vehicles and energy storage systems. In the longer term, lithium batteries may even replace traditional

lead-acid car batteries for starting, lighting and ignition (SLI), leading to much higher demand (Ferg, Schuldt, and Schmidt 2019).

In primary batteries, zinc is the main substitute to replace lithium as anode material in the cell (Graedel et al. 2015b), as well as calcium, magnesium, and mercury (Bradley et al. 2017).

Sodium and potassium fluxes can be used instead of lithium in ceramics and glass manufacturing (Peterson 2017), but with a loss of performance, as they do not improve the thermal shock resistance to the same degree as lithium fluxes (Evans 2014).

Alternative formulations with polyurea, calcium and aluminium soaps, can substitute for lithium stearates in lubricating greases (Saruls 2017)(Bradley et al. 2017).

In electronics, lanthanum and gallium are substitutes for lithium tantalite in electronics used in surface acoustic wave filters for sensors (Tercero et al. 2015). In air conditioning and dehumidification systems, substitution with ammonia/water systems is possible but with reduced performance (Graedel et al. 2015b). For primary aluminium production and continuous casting, sodium is a potential substitute (Graedel et al. 2015a). Composite materials consisting of boron, glass, or polymer fibres in engineering resins can be used in place of aluminium-lithium alloys (Bradley et al. 2017). Finally, no substitutes exist for the applications of pharmaceuticals and polymer production (Graedel et al. 2015b).

In the criticality assessment, substitution was assessed for glass and ceramics, and lubricating greases. The rest of the applications were not evaluated due to less than 10% share in total end uses.

On a scale of 0 to 100<sup>134</sup>, (Graedel et al. 2015b) assessed the substitutability of lithium to 41.

## **14.4 Supply**

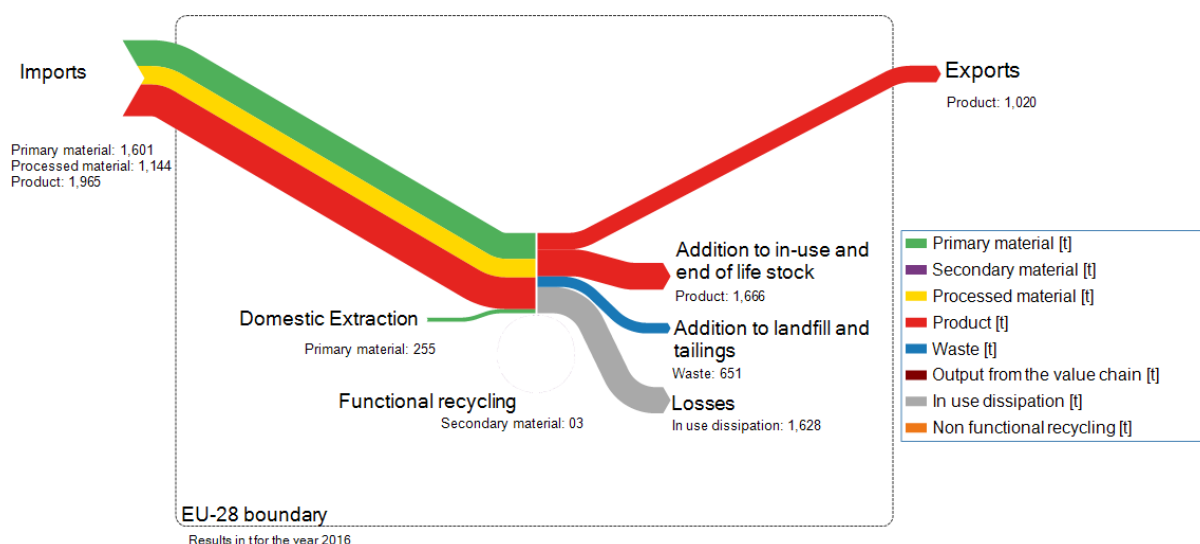
---

### **14.4.1 EU supply chain**

The lithium flows through the EU economy are shown in Figure 180.

---

<sup>134</sup> On this scale, zero indicates that exemplary substitutes exist for all major uses and 100 indicates that no substitute with even adequate performance exists for any of the major uses.



**Figure 180: Simplified MSA of lithium flows in the EU, 2016 (MSA 2019)**

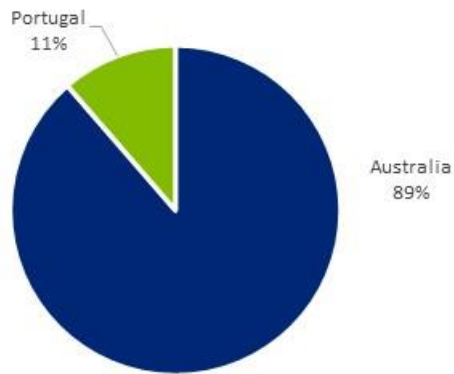
#### 14.4.1.1 EU sourcing of lithium ores and concentrates

Lithium is currently extracted in Portugal in the form of lepidolite and marketed as Li-rich feldspars used by the ceramics industry. Six mining sites were registered as active in 2017 at the Guarda (Alvarrões), Braga (Gondiães) and Villa Real (Alijó, Lousas, Mina do Barosso) districts (Dinis P. and Horgan S 2018). The annual production over 2012-2016 averaged to about 24,000 tonnes of lepidolite minerals (BGS 2019).

Since 2011, production from Spain is not included in statistics published by common sources such as the British Geological Survey's World Mineral Statistics, World Mining Data or the United States Geological Survey. However, there are reports that Li-containing minerals were extracted in Spain at about 8 kt tonnes per year of gross weight in the 2011-2014 period for use in the ceramics industry (Regueiro y González-Barros 2016), while the French Geological Survey reports a small production of lepidolite concentrates in Spain of 100 tonnes in LCE content in 2015 (BRGM 2017). In addition, small quantities of lithium are produced in the form of Li-rich mica concentrates as a co-product of kaolin mining at Échassières, France for use in the glass industry, but production is also not published by mine statistics providers. The estimated output in 2015 was 15 kt of concentrates at a grade of 1.8% of  $\text{Li}_2\text{O}$  (BRGM 2017d).

The annual EU sourcing of lithium ores and concentrates is estimated at about 980 tonnes of lithium content averaged over 2012-2016. Under the HS or CN nomenclature, lithium ores and concentrates are grouped with many other commodities in the code HS 260790 "Other ores and concentrates, not elsewhere specified", therefore disaggregated imports data are not available in Eurostat Comext database. However, the imports of lithium ores and concentrates were estimated at 868 tonnes of Li according to data provided by (CRM validation workshop 2019). The data refers to exports of spodumene concentrates from Australia to the EU, assuming a 5%  $\text{Li}_2\text{O}$  content. It is also assumed that Australia is the only sourcing country of EU imports of Li ores and concentrates. Import reliance is 87%.

Figure 181 shows the EU sourcing (domestic production + imports) of lithium concentrates.



EU sourcing of Li concentrates : 980 tonnes

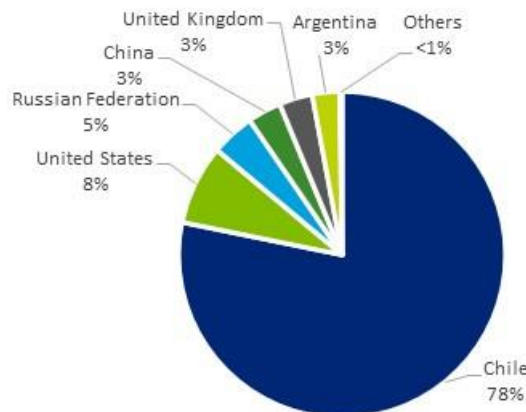
**Figure 181: EU sourcing (domestic production + imports) of lithium concentrates, average 2012-2016. Data from (WMD 2019), (CRM validation workshop 2019)**

#### 14.4.1.2 EU sourcing of refined lithium

No metallurgical processing of chemical-grade lithium concentrates is taking place in the EU. Downstream lithium compounds such as butyl-lithium, lithium chloride, and lithium metal are produced at Langelshiem in Germany by Albemarle from imported lithium carbonate (Albemarle 2019)(USGS 2018).

Therefore, the EU is entirely reliant on imports of refined lithium, i.e. carbonates and hydroxides (import reliance of 100%). The principal supplier of the EU for refined lithium compounds is Chile (78% of total EU sourcing).

Figure 182 presents the EU sourcing (domestic production + imports) of lithium compounds (carbonates and hydroxides).



EU sourcing of refined lithium: 3,101 tonnes

**Figure 182: EU sourcing (domestic production + imports) of refined lithium compounds, average 2012-2016. Data from (ESTAT Comext 2019)**



### 14.4.1.3 Supply of recycled lithium

The majority of end-uses of lithium are dissipative. Lithium is either not available for recycling at all, or extremely hard to be recovered. Only lithium embedded in batteries is available for recycling.

Recycling of Li-ion batteries is carried out by specialised companies, with a total processing capacity for all battery types of more than 40,000 tonnes of batteries (Table 77). Valdi in France has the largest capacity at 20,000 tonnes/year of various types of batteries. Umicore's plant in Hoboken, Belgium, with a total annual capacity of 7,000 tonnes for all battery types, enables the treatment of around 250,000 mobile phone batteries, 2,000,000 E-bike batteries, 200,000 HEV batteries and 35,000 EV batteries (Patrícia Alves Dias et al. 2018). Duesenfeld in Germany set up a plant with a capacity of 3,000 tonnes of Li-ion batteries in 2018 (Roskill 2019). Accurec in Germany recycles annually 1,500-2,000 tonnes of Li-ion batteries, while AkkuSer in Finland treats 1,000 tonnes of Li-ion batteries annually (Lebedeva, Di Persio, and Boon-Brett 2017). With a large share of the global recycling capacity located in Europe, it is likely that in the future, EU recycling facilities will expand their processing capacities and attract significant volumes from abroad (Patrícia Alves Dias et al. 2018). Table 77 presents the facilities undertaking recycling of Li-ion batteries in the EU.

**Table 77: Overview of plants with the capacity to recycle Li-ion batteries. Data from (Patrícia Alves Dias et al. 2018)(Roskill 2019)**

Company	Country (location)	Battery types	Annual capacity (tonnes of all battery types)
Valdi (Eramet)	France (Commentry)	Various including Li-ion	20,000
Umicore SA	Belgium (Hoboken)	Li-ion, NiMH	7,000
Accurec GmbH	Germany (Mulheim, Krefeld)	NiCd, NiMH, Li-ion, Li primary	6,000
Akkuser Oy	Finland (Nivala)	NiCd, NiMH, Li-ion, Zn alkaline	4,000
Duesenfeld GmbH	Germany (Wendeburg)	Li-ion	3,000
SNAM	France (Saint Quentin Fallavier)	NiCd, NiMH, Li-ion	300
Eurodieuze (SARPI)	France (Dieuze)	Li-ion	200
Recupyl SA	France (Grenoble)	Li-ion, Li primary	110
Total			40,610

Umicore Battery Recycling has announced lithium recovery from the slag fraction of its pyrometallurgical process on an industrial level (Hagelüken 2018). Also, Recupyl in France

patented a hydrometallurgical recycling process enabling Li recovery on an industrial scale (Lebedeva, Di Persio, and Boon-Brett 2017). Lastly, Duesenfeld applies a patented technology for recycling Li-ion batteries, developed within the frame of the research project Lithorec II, allowing lithium recovery of at least 85% combining mechanical processing with subsequent hydrometallurgical processing (Duesenfeld 2019). Recovery of lithium is planned at the Accurec facility in Germany after a planned investment in thermal deactivation and treatment of spent lithium batteries, which will make it one of the most significant lithium recycling locations globally (Recharge 2018). No information is available from other recycling facilities in the EU on current industrial-scale lithium recovery.

## 14.4.2 Supply from primary materials

### 14.4.2.1 Geology, resources and reserves of lithium

**Geological occurrence:** Estimates for the average lithium content in the Earth's crust range from 16 to 20 ppm (BGS 2016) (Rudnick and Gao 2014), but lithium abundance ranges from about 30 ppm in igneous rocks to approximately 60 ppm in sedimentary rocks (Evans 2014). According to (Rudnick and Gao 2014), the abundance of lithium in the upper crust is 24 ppm. Lithium also occurs in various types of brines, as well as in seawater at an average concentration of 0.18 ppm (BGS 2016).

Because of its high reactivity, lithium does not occur in elemental form in nature, but in the form of compounds as silicates in igneous rocks, in some clay minerals and generally as chloride in brines (Evans 2014). There are more than 100 known minerals that may contain lithium, but few with enough lithium content to be economical to extract (BGS 2016). Two distinct deposit types are identified from which lithium can be extracted; brine deposits in which the average lithium grade is about 0.1% Li<sub>2</sub>O, and hard-rock deposits where lithium generally grades from 0.6 to 1.0% Li<sub>2</sub>O hosted by various Li-bearing minerals (Gautneb et al. 2019).

Continental brine deposits contain substantial lithium resources. These brines are formed in enclosed basins where inflowing surface and underground water with a medium content of dissolved solids from surrounding weathered rocks become mineral-rich due to evaporation on high ambient temperatures (Evans 2014). Economic Li deposits of brines mainly occur in areas where arid climate and high evaporation has resulted in further lithium enrichment (0.04-0.15% Li average grade) originating from weathered Li-bearing source rocks; these deposits are usually associated with salt lakes or salt pans (BGS 2016). Likewise, economically viable concentrations of lithium are found in geothermal and oilfield brines where lithium extraction has been demonstrated as a by- or co-product of existing operations, although not yet on a commercial scale (BGS 2016) (Bradley et al. 2017).

Brine resources are mostly found in South American countries – Chile, Argentina and Bolivia – in an area known as the "Lithium Triangle", which contains half of the world's lithium resources and 70% of global reserves at the end of 2018. Bolivia hosts the most abundant lithium brine resource in the world (Salar de Uyuni); however, it has not been exploited until 2016, but action has been undertaken in this direction. Currently, most lithium extraction from brines comes from the Salar de Atacama in Chile; other significant brine-based deposits are located at Salar del Hombre Muerto and Salar de Olaroz in Argentina. Brine operations in South America accounted for 55% of global lithium supply in 2016. Other brine deposits, though of generally lower grade, are located in the USA (e.g. Silver Peak) and China (e.g. Qinghai province).

In hard-rock deposits, lithium-bearing minerals are generally associated with granitic pegmatite deposits. Pegmatites are coarse-grained igneous rocks formed at the late stages of magmatic crystallisation. Even though pegmatites are relatively common, lithium-rich pegmatites are rarely found, and may also contain minerals of tantalum, caesium, beryllium or tin (Bradley et al. 2017) (BGS 2016).

Spodumene ( $\text{LiAlSi}_2\text{O}_6$ ) is the most important and abundant of lithium-bearing minerals hosted by granitic pegmatites. Lepidolite ( $\text{KLi}_2\text{AlSi}_4\text{O}_{10}\text{F}_2$ ) and petalite ( $\text{LiAlSi}_4\text{O}_{10}$ ) are other common lithium minerals of economic importance found in pegmatite intrusions. Amblygonite ( $\text{LiAl}(\text{PO}_4)(\text{F},\text{OH})$ ) and eucryptite ( $\text{LiAlSiO}_4$ ) occur in smaller quantities and are of lower economic significance. The world's largest lithium-rich pegmatite deposit and operating mine is Australia's Greenbushes in Western Australia, in which spodumene reserves grade up to 3.9%  $\text{Li}_2\text{O}$ . Other important hard rock deposits are located in North Carolina, USA, at Manono-Kitolo in the Democratic Republic of Congo, at Bikita in Zimbabwe and Tanco in Canada. Hard rock lithium deposits around the world are currently mined in Australia (spodumene), China (spodumene and lepidolite), Brazil (spodumene), Portugal (lepidolite) and Zimbabwe (petalite and spodumene). (Bradley et al. 2017) (BGS 2016)

Finally, two types of lithium ore deposits occurring in different geological settings than pegmatites – lithium clays and lithium zeolites – have been recognised. The lithium-bearing clay deposits (hectorite,  $\text{Na}(\text{Mg},\text{Li})_3\text{Si}_4\text{O}_{10}(\text{OH})_2$ ) identified in the United States, Mexico and Morocco, and the lithium zeolite deposit at Jadar in Serbia containing the recently discovered mineral of jadarite ( $\text{LiNaSiB}_3\text{O}_7(\text{OH})$ ), are under evaluation for future lithium extraction (Bradley et al. 2017) (BGS 2016).

The spatial distribution of geological occurrences in Europe shows a strong clustering highlighting lithium potential of the Variscan belt of south and central Europe (Gautneb et al. 2019). Lithium deposit types can be broadly classified to:

- *high-grade* Li deposits, represented by Li-rich lithium-cesium-tantalum pegmatites such as Wolfsberg in Austria, San Jose in Spain, Rapasaari in Finland and Sepeda in Portugal, rare metal granites such as Beauvoir in France, and atypical stratiform deposits such as Jadar in Serbia;
- *medium-grade* Li deposits, represented by hydrothermal greisens such as Cinovec in Czechia, Li-bearing quartz veins such as Argemela in Portugal;
- *other types*.

**Global resources and reserves**<sup>135</sup>: Worldwide lithium resources have increased significantly in recent years on account of continuing exploration. The United States Geological Survey estimates the global resources of lithium at the end of 2018, at about 62 million tonnes of contained Li (USGS 2019). The largest identified lithium resources worldwide are located in Argentina (14.8 Mt, 24%), Bolivia (9 Mt, 15%), Chile (8.5 Mt, 14%), Australia (7.7 Mt, 12%), United States (6.8 Mt, 11%) and China (4.5 Mt, 7%). The world's reserves of lithium are estimated at 14 million tonnes in Li content, with the most significant reserves held by Chile, Argentina, Australia and China (USGS 2019d) (see Table 78).

---

<sup>135</sup> There is no single source of comprehensive evaluations for resources and reserves that apply the same criteria to deposits of lithium in different geographic areas of the EU or globally. The USGS collects information about the quantity and quality of mineral resources but does not directly measure reserves, and companies or governments do not directly report reserves to the USGS. Individual companies may publish regular mineral resource and reserve reports, but reporting is done using a variety of systems of reporting depending on the location of their operation, their corporate identity and stock market requirements. Translations between national reporting codes are possible by application of the CRIRSCO template, which is also consistent with the United Nations Framework Classification (UNFC) system. However, reserve and resource data are changing continuously as exploration and mining proceed and are thus influenced by market conditions and should be followed continuously.

**Table 78: Global reserves of lithium in 2018. JRC elaboration based on data from (USGS 2019) and industry announcements for the EU<sup>136</sup>**

Country	Lithium Reserves (in tonnes of Li)	Percentage of the total (%)
Chile	8,000,000	56
Australia	2,700,000	19
Argentina	2,000,000	14
China	1,000,000	7
Czechia	104,000	<1
Germany	94,000	<1
Zimbabwe	70,000	<1
Brazil	54,000	<1
Portugal	53,000	<1
Finland	36,000	<1
United States	35,000	<1
Austria	25,000	<1
World total (rounded)	14,200,000	

**EU resources and reserves:** Table 79 and Table 80 present available data on EU lithium resources and reserves based on the ongoing progress of exploration and mine development projects.

**Table 79: Lithium resources data in the EU**

Country	Classification	Quantity (million tonnes of ore)	Grade (%Li <sub>2</sub> O)	Reporting code	Reporting date	Source
Austria	Measured	2.86	1.28	JORC	03/2018	(European Lithium Ltd 2018)
	Indicated	3.44	1.08			
	Inferred	4.68	0.78			
Czechia	Measured	-	-	JORC	11/2017	(European Metals Ltd 2017b)
	Indicated	372.4	0.44			
	Inferred	323.5	0.39			
Finland	Historic Resource Estimates	0.15	0.83 (Li)	None	12/2017	(FODD 2017)
	Measured	1.21	1.24	JORC	05/2018	(Keliber Oy 2018)
	Indicated	8.26	1.15			
	Inferred	0.53	1.08			
France	Measured	0.023 (Li <sub>2</sub> O content)	NA	None	12/2018	(Gloaguen et al. 2018)
	Indicated	0.069 (Li <sub>2</sub> O content)	NA			
	Inferred	0.443 (Li <sub>2</sub> O content)	NA			
Germany <sup>137</sup>	Inferred	13.726 km <sup>3</sup>	181 mg/l (Li)	JORC	12/2019	(Vulcan Energy Resources 2019)

<sup>136</sup> (Deutsche Lithium GmbH, 2018)(Dinis P. and Horgan S, 2018)(European Lithium Ltd, 2018)(European Metals Ltd, 2017a) and (Keliber Oy, 2018) for Germany, Portugal, Austria, Czechia and Finland respectively

<sup>137</sup> Geothermal Brine

Country	Classification	Quantity (million tonnes of ore)	Grade (%Li <sub>2</sub> O)	Reporting code	Reporting date	Source
Germany	Inferred	25	0.45	JORC	12/2017	(Lithium Australia 2017)
Germany	Measured	18.51	0.78	NI 43-101	10/2018	(Deutsche Lithium GmbH 2018)
	Indicated	17	0.73			
	Inferred	4.87	0.76			
Ireland	Historic Resource Estimates	0.57	1.5	None	01/2015	(Minerals4EU 2019)
Portugal <sup>138</sup>	Measured	6.6	1.10	JORC	04/2019	(Savannah Resources Plc 2019b), (Lepidico Ltd 2019), (Dakota Minerals 2017), (PANNN 2017)
	Indicated	15.6	0.82			
	Inferred	32.07	0.91			
Spain	Measured	-	-	JORC	05/2018	(Infinity Lithium Ltd 2018)
	Indicated	59	0.63			
	Inferred	52.2	0.59			
Sweden	Historic Resource Estimates	0.6	0.45 (Li)	None	07/2017	(FODD 2017)
		0.4	0.12 (Li)		12/2017	

**Table 80: Lithium reserves data in the EU**

Country	Classification	Quantity (Mt of ore)	Grade (%Li <sub>2</sub> O)	Li(kt) <sup>139</sup>	Rep. code	Rep. date	Source
Austria	Proved	4.32	0.69	14	JORC	03/2018	(European Lithium Ltd 2018)
	Probable	3.12	0.75	11			
Czechia	Proved	-	-	-	JORC	06/2017	(European Metals Ltd 2017a)
	Probable	34.5	0.65	104			
Finland	Proved	1.14	1.12	6	JORC	05/2018	(Keliber Oy 2018)
	Probable	6.26	1.02	30			
Germany	Proved	16.5	0.66	51	NI43-101	05/2019	(Deutsche Lithium GmbH 2019)
	Probable	14.7	0.63	43			
Portugal <sup>140</sup>	NA	10.7	1.06	53	NA	2018	(Dinis P. Horgan S 2018)

<sup>138</sup> Ongoing exploration and mine development projects Mina do Barosso, Alvarrões, Sepeda and Argemela.

<sup>139</sup> Rounded values

<sup>140</sup> Total reserves of the existing mining concessions

#### 14.4.2.2 Exploration and new mine development projects in the EU

Mineral exploration activities targeting lithium are in progress across the EU. The recent developments for projects having reached a more advanced stage are listed below:

- *Austria*. At the Wolfsberg spodumene deposit, total lithium mineral reserves and resources reported in April 2018 under the JORC Code amount to 7.5 million tonnes (0.71% Li<sub>2</sub>O average grade) and 11 million tonnes (1.00% Li<sub>2</sub>O average grade) respectively. A pre-Feasibility study is completed. (European Lithium Ltd 2018);

- *Czechia*. JORC compliant total lithium resources estimate of the Cinovec deposit are announced in November 2017 to be almost 700 million tonnes (0.42 % Li<sub>2</sub>O average grade), making it the largest lithium deposit in Europe. Lithium is present in the lithium-bearing mica of zinnwaldite (KLiFeAl(AlSi<sub>3</sub>)O<sub>10</sub>(F,OH)<sub>2</sub>). A preliminary feasibility study has been completed, and the definitive feasibility study is ongoing. (European Metals Ltd 2017b);

- *Finland*. JORC compliant estimates of total resources for spodumene deposits in pegmatites have been announced in February 2019 to be 9.5 million tonnes at 1.16% Li<sub>2</sub>O average grade. Total reserves are estimated at 7.4 million tonnes at 1.04 % Li<sub>2</sub>O average grade. This figure is cumulative for six distinct deposits in the area, i.e. Syväjärvi, Rapasaari, Länttä, Outovesi, Emmes and Leviäkangas. The definitive Feasibility study (covering operations in the above deposits as a single project) is completed and updated (Keliber Oy 2018) (Keliber Oy 2019);

- *Germany*. Total lithium resources of the Zinnwald deposit reported under NI 43-101 requirements are approximately 40 million tonnes at 0.76 % Li<sub>2</sub>O, as of October 2018 (Deutsche Lithium GmbH 2018). Lithium mineralisation is represented by the zinnwaldite lithium mica. A feasibility study is concluded (May 2019) and mineral reserves account for 31.2 million tonnes at 0.65 % Li<sub>2</sub>O average grade (Deutsche Lithium GmbH 2018). In addition, an inferred lithium mineral resource of 25 million tonnes grading 0.45 % Li<sub>2</sub>O at the Sadisdorf project is announced (December 2017) based on re-analysis and re-interpretation of historical drilling data (Lithium Australia 2017); Last but not least, vast JORC-compliant lithium resources were announced in December 2019 to be contained in geothermal brines at the Vulcan lithium brine project in the Upper Rhine valley of Germany. Total inferred mineral resources are estimated to 2.484 million tonnes of lithium, at a lithium brine grade of 181 mg/l Li (Vulcan Energy Resources 2019);

- *Portugal*. According to information published in September 2017 by the Portuguese Lithium Working Group (Lithium Working Group, 2017) based on reports by operating mining companies, total resources in Portugal were estimated at approximately 30 million tonnes at an average grade of 0.81 % Li<sub>2</sub>O (Lithium Working Group, 2017). However, as exploration and mine development projects are in progress, JORC compliant lithium resources of the active projects are estimated at the end of 2018 to be about 43 million tonnes at an average grade of 0.88 % Li<sub>2</sub>O. In particular:

- The latest (May 2019) JORC compliant update of the overall mineral resource estimate of the ongoing spodumene mine development project Mina Do Barroso in northern Portugal amounts to 27 million tonnes at 1.06 % Li<sub>2</sub>O (Savannah Resources Plc 2019b). A Feasibility study is on track (Savannah Resources Plc 2019a);
- The JORC compliant mineral resource estimate for the ongoing exploration project in the Alvarrões lepidolite mine is 5.9 million tonnes at 0.87 % Li<sub>2</sub>O (April 2019). Advanced exploration by drilling has been completed (Lepidico Ltd 2019);
- Exploration is also underway in the Sepeda deposit. The last available (February 2017) JORC compliant mineral resource estimate is 10.3 million tonnes at 1.0% Li<sub>2</sub>O. A scoping study has been finalised (Dakota Minerals 2017);
- Exploration works are ongoing in the Argemela tin-lithium project (Patricia Alves Dias 2018). In 2012, JORC-compliant mineral resources were estimated to be 11.1 million tonnes grading 0.21 % Li (PANNN2017).

- *Spain*. The San Jose deposit, where lithium is hosted mainly in lithium-mica minerals, holds in total 111 million tonnes of JORC compliant estimated resources at an average grade of 0.61 % Li<sub>2</sub>O average grade, as announced in May 2018. A Feasibility study is underway (Infinity Lithium Ltd 2018).

Moreover, the Jadar lithium-borate deposit in Serbia, discovered by Rio Tinto in 2004, represents a massive lithium deposit. Lithium is hosted by the previously unknown borosilicate mineral jadarite. The deposit contains 136 million tonnes of ore at a grade of 1.9%  $\text{Li}_2\text{O}$  that is equivalent to about 2.6 Mt of  $\text{Li}_2\text{O}$ . The pre-feasibility study is on-going for a mine and processing facility, and production could commence by 2023-2024 (Rio Tinto 2018), (Rio Tinto 2017), (Gautneb et al. 2019).

#### **14.4.2.3 Lithium extraction**

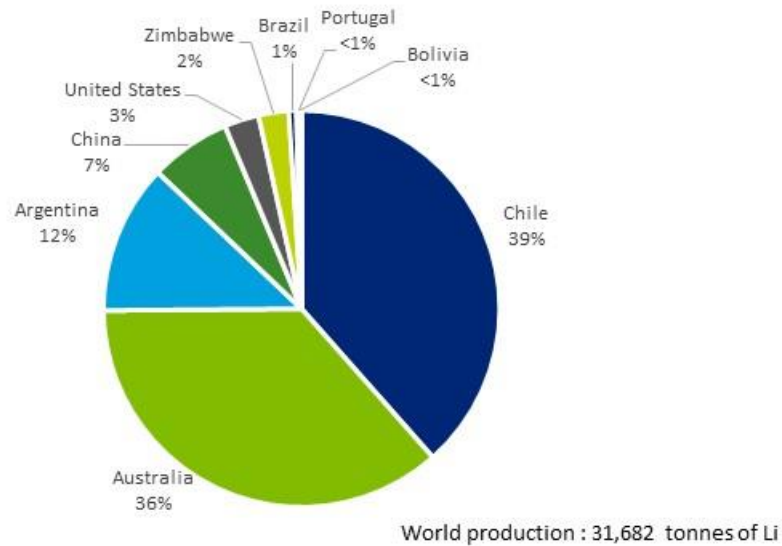
Conventional drill and blast mining techniques for hard rock lithium ores are applied in open-pit or underground mines. Once extracted, the ore is crushed and ground in the beneficiation facility at or close to the mine site. The Li-bearing minerals can then be liberated from gangue minerals via various physical separation methods taking advantage of differences in their properties, e.g. screening and gravity separation, heavy-media separation, optical sorting. Different separation processes produce a concentrate with differing levels of lithium oxide ( $\text{Li}_2\text{O}$ , also known as lithia) content. In some cases, the concentrated ore has to be further upgraded by removing entrained minerals; froth flotation for separating micaceous minerals and magnetic separation when paramagnetic minerals are present, are techniques commonly applied. Finally, the wet concentrate is filtered, dried and marketed (BGS 2016).

Hard-rock lithium concentrates need to be further refined for value-added applications. A typical concentrate, suitable for downstream lithium carbonate and other lithium compounds production, generally contains between 6-7%  $\text{Li}_2\text{O}$  ("chemical-grade concentrate"). Higher grade spodumene concentrates, with a lower level of impurities such as iron (i.e. less than 0.1%  $\text{Fe}_2\text{O}_3$ ), are known as "technical-grade concentrates" and can be directly consumed in mineral form by manufacturing industries (e.g. glass and ceramics) without going through any refining process (Hocking et al. 2016).

In brine-based operations, lithium-rich brine is pumped to the surface from underground reservoirs/aquifers by a series of wells or boreholes and is concentrated by solar evaporation in a succession of artificial ponds. Lime is added to precipitate impurities. It takes 9-12 months or even more to achieve a concentrate that is both enriched in lithium and depleted in other elements. The concentrated liquor from the last pond is then transferred to processing plants for the production of lithium compounds (BGS 2016). The end products derived from brine operations can be used directly in value-added applications.

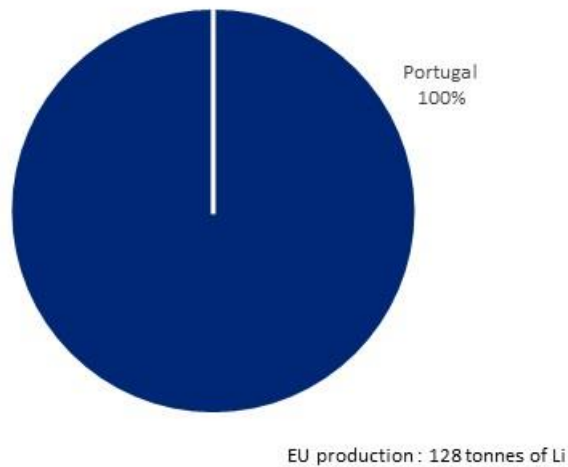
#### **14.4.2.4 World and EU production of lithium**

As an annual average over the period 2012-2016, the global production of lithium was about 68,190 tonnes of  $\text{Li}_2\text{O}$  content (WMD 2019), which corresponds to approximately 31,680 tonnes on contained metal terms or 168,600 tonnes of LCE (lithium carbonate equivalent). Lithium is currently extracted in Australia, China, Zimbabwe, Portugal and Brazil from hard rocks, whereas in Chile, Argentina, China and USA lithium is extracted from brines (BGS, 2016). Chile is the most important producer (37%), followed by Australia (33%), China (12%) and Argentina (11%) (see Figure 183). In 2015, around 50% of lithium supply came from lithium brines, approximately 45% from hard-rock spodumene ores, while other lithium minerals accounted for 5 to 10% (Hocking et al. 2016).



**Figure 183: Global mine and brine production of lithium, in Li content. Average for the years 2012-2016. Background data from (WMD 2019)**

In the EU, about 128 tonnes of lithium were extracted annually (average over 2012-2016) in Portugal in the form of lepidolite.



**Figure 184: EU production of lithium ores and concentrates, in Li content. Average for the years 2012-2016. Background data from (WMD 2019)**

### 14.4.3 Processing/Refining of lithium

A variety of lithium compounds that can be produced in processing plants including lithium carbonate, lithium hydroxide, lithium chloride, lithium bromide, lithium metal, butyllithium. Lithium carbonate is the precursor of most other lithium compounds in the refining stage.

In brine operations, processing methods vary considerably depending on the overall chemistry. In the basic process, the concentrated Li-rich brine (around 6,000 ppm Li) is treated with sodium carbonate to precipitate lithium carbonate slurry. A pure lithium



carbonate product is obtained after filtering, washing, and drying. Potassium, magnesium and boron salts (e.g. KCl) may be recovered as co-products. Lithium chloride and lithium hydroxide can be produced via different processing routes.

The chemical-grade mineral concentrates undergo additional processing in refining plants to produce a variety of lithium chemicals or lithium metal. Different metallurgical methods are applied to recover lithium from its ores; the most commonly used for spodumene is the acid leaching process. Other refining processes include the autoclave carbonate leaching and the lime leaching method.

The acid leaching process involves high-temperature calcination of the concentrate at about 1,100 °C to improve the solubility of spodumene in acids, followed by acid digestion at 200-250 °C with sulphuric acid. Lithium from spodumene forms lithium sulphate, which is soluble in water; thus, a downstream water leaching step produces a solution of lithium sulphate. Impurities are removed by filtration, precipitation, and ion-exchange techniques. Finally, the recovery of lithium from the liquor is carried out by adding a carbonate donor like sodium carbonate ( $\text{Na}_2\text{CO}_3$ ) at 80-100 °C to precipitate insoluble lithium carbonate (carbonation step). The purity of lithium carbonate can be improved by a series of re-dissolution/precipitation/ion exchange steps to achieve up to 99.9% grade. Industry-grade lithium carbonate generally has a purity of 98.5-99.0%, while battery-grade lithium carbonate must have a higher purity of at least 99.5%.

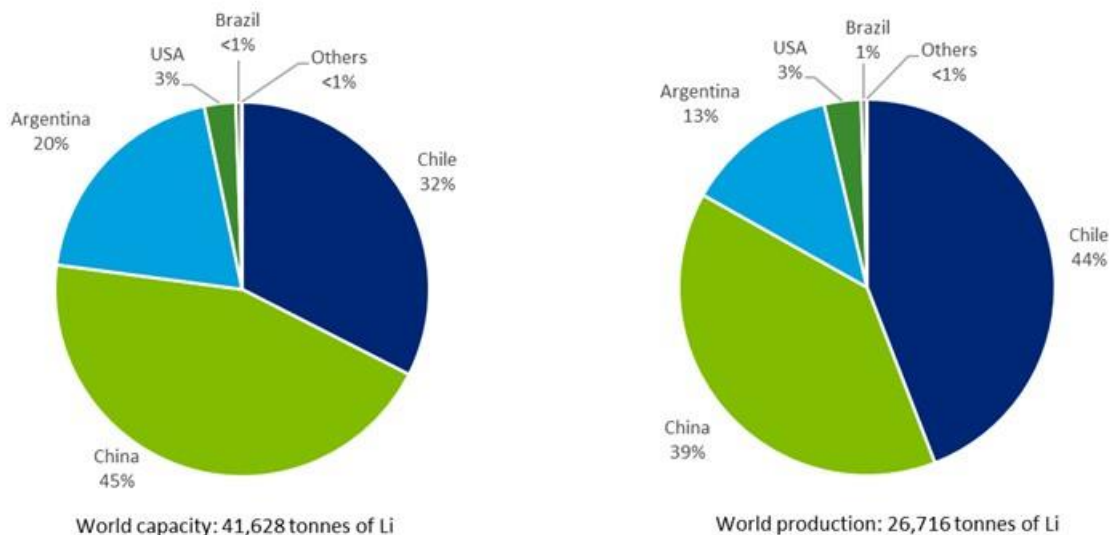
For the production of lithium hydroxide, in the typical processing route of acid leaching and before the carbonation step, the aqueous liquor after removal of impurities may undergo electro dialysis to produce a lithium hydroxide solution, and crystallisation to form a high-purity lithium hydroxide product. Alternatively, lithium hydroxide is produced by a chemical reaction between lithium carbonate and calcium hydroxide.

Lithium chloride is mainly produced in brine operations, also by treating lithium carbonate with hydrochloric acid. Lithium bromide is produced by lithium carbonate after treatment with hydrobromic acid. Lithium metal is obtained by electrolysis of lithium chloride and potassium chloride mixture, in the form of ingots, rods, foils, granules, and powders. Finally, butyl-lithium and other organolithium compounds are produced from lithium metal.

#### **14.4.3.1 World and EU production of refined lithium**

There are no publicly available statistics on the production of refined lithium. China hosts the majority of the world's lithium refining facilities from hard-rock minerals, and Chile the most of the world's capacity from brine operations. The global capacity and world production of refined lithium compounds (Li carbonates and Li hydroxides) in 2015 was reported to be about 41,628 tonnes and 26,716 tonnes respectively.

The production of refined lithium compounds in the EU is negligible (Draft lithium MSA 2019).



**Figure 185: World production and world capacity of processed lithium in 2015, in lithium content. Data from (M Schmidt 2017)**

#### 14.4.4 Supply from secondary materials/recycling

Lithium recycling has long been insignificant because of dissipative end-uses (e.g. lubricating greases, metallurgy), not functional recycling (e.g. glass and ceramics), or reusable end-uses (such as catalysts) (BIO Intelligence Service 2015), (BGS 2016). The only waste flow with lithium recycling potential is spent Li batteries (Nogueira 2017).

Recycling of lithium-ion batteries, which is a complex and costly process hindered by the wide variety of chemistries and battery formats, has attracted much attention during the last years due to the constantly increasing significance of Li-ion batteries, especially in the rapidly growing electric vehicle sector. At the same time, regulatory instruments already applicable in the EU, such as Directive 2000/53/EC (End-of-Life Vehicles Directive), Directive 2012/19/EU (Waste Electrical and Electronic Equipment Directive), and Directive 2006/66/EC (Batteries Directive), aim to achieve a high level of recycling for waste Li-ion batteries in electric vehicles and electronic equipment.

Nowadays, the recovery of lithium from batteries is technically feasible, but until 2017 industrial-scale recycling was considered not cost-effective in comparison with primary supplies. As a result, the main focus of Li-ion battery recycling plants has been the recovery of cobalt, nickel, and copper, which have a higher economic value than lithium (BGS 2016). At a global scale, only a minor amount (20 tonnes in 2016) of Li recovery is reported from secondary sources (BRGM 2017). Nevertheless, given the recent introduction of EVs on the European market, and taking into account the average lifetime of EV components (estimated to be approximately ten years), a significant number of EVs have not yet reached end-of-life (European Commission 2018a).

Hydrometallurgical recycling methods of end-of-life Li-ion batteries enable recovery of lithium as a lithium carbonate precipitate. Instead, in pyrometallurgical processes, lithium remains in the slag, which can be used as a construction material (non-functional recycling) (BGS 2016), or further processed by hydrometallurgical methods to recover lithium.

Recycling of Li-ion batteries has the potential to create a continuous and secure secondary stream of lithium supply for the EU in the future (Blagoeva et al. 2016), under conditions that will make it economically attractive e.g. higher lithium prices, market of scale.

According to (BIO Intelligence Service 2015) no recycling of lithium is taking place in the EU, therefore the end-of-life recycling input rate (EOL-RIR) is 0%. Lithium employed in the glass and ceramics industry is used up in the production process and cannot be recycled (Christmann et al. 2015).

## **14.5 Other considerations**

---

### **14.5.1 Environmental and health and safety issues**

Lithium metal is highly reactive and flammable in its elemental form, even potentially explosive; it cannot be stored in air or water. Nevertheless, it is not found in nature in elemental form and its compounds are non-flammable (Bradley et al., 2017) (BGS, 2016).

Lithium is neither an environmental nor a human health concern at ambient conditions (Bradley et al. 2017). Lithium salts have neurological and psychiatric medical properties. Only some mixed arsenic-lithium substances are restricted (Annex XVII) under the REACH regulation (ECHA 2019).

A supply risk, associated with a very high risk of exposure to natural hazards (Bündnis Entwicklung Hilft 2019), and high water stress (World Resources Institute 2019) is identified in Chile, the leading supplier globally.

### **14.5.2 Contribution to low-carbon technologies**

Lithium is a key material for hybrid and electric vehicles as most hybrid electric vehicles (HEVs), and all plugin hybrid electric vehicle (PHEVs) and battery electric vehicles (BEVs) marketed today use Li-ion batteries (Harvey 2018). In addition, Li-ion batteries are employed in energy storage systems for renewable energy (M Schmidt 2017).

Another contribution to the transport sector is the use of novel, low-density Al-Li alloys for aircraft building which provide weight reduction and improve fuel economy (Marscheider-Weidemann et al. 2016).

### **14.5.3 Socio-economic issues**

The level of governance in countries supplying lithium to EU is medium to high. Only a minor share of the global supply (3%) derives from a country (Zimbabwe) with deficient governance level and conflict risk (World Bank 2018).

## **14.6 Comparison with previous EU assessments**

---

The assessment has been conducted using the same methodology as for the 2017 list. In the current assessment, the supply risk has been analysed separately at the mine, and the processing stage. In the processing stage, the materials analysed were lithium carbonate and lithium hydroxide. It has to be noted that in the 2017 assessment, a 'hybrid' approach was applied due to lack of data, i.e. production data from mines and brines were used for the calculation of the global HHI, and trade data for the most important lithium compounds (lithium carbonate and lithium hydroxide) for the calculation of the EU HHI. The results of the current and earlier assessments are shown in Table 81.

**Table 81: Economic importance and supply risk results for lithium in the assessments of 2011, 2014, 2017, 2020 (European Commission 2011-2014-2017)**

Assessment	2011		2014		2017		2020	
Indicator	EI	SR	EI	SR	EI	SR	EI	SR
Lithium	5.6	0.7	5.5	0.6	2.4	1.0	3.1	1.6

The results of the older assessments are not comparable due to the introduction of a revised methodology in the 2017 assessment. In particular, the economic importance appears reduced in the 2017 assessment as the value-added considered in the 2017 criticality assessment corresponds to a 2-digit NACE sector rather than a 'megasector' (which was used in the 2011 and 2014 assessments).

In the current assessment, the Supply Risk indicator (SR) was calculated using both the HHI for global supply and EU supply as prescribed in the revised methodology. The assessment results reveal that the processing stage has a higher supply risk (SR=1.64) compared to the extraction stage (SR=1.33). The overall supply risk for lithium is considered for the stage with the highest score, i.e. SR=1.64 (rounded to 1.6). The supply risk results are not directly comparable to the 2017 assessment, as a different approach was applied for the definition of the value-chain stages. However, for the components of the supply risk which are comparable, it is noted a slightly higher supply risk for the global HHI of lithium ores and concentrates due to the moderate increase of the world production share that the top-2 producing countries hold (i.e. Chile and Australia).

Also, the Economic Importance indicator (EI) is higher in the current assessment compared to the 2017 exercise. The main reason is that the application 'Lubricating greases' is allocated more appropriately to the NACE 2-digit level sector 'C20 - Manufacture of chemicals and chemical products', instead of the sector 'C19 - Manufacture of coke and refined petroleum products' as in the 2017 exercise. The increase in the EI indicator is also affected to some extent by the results scaling step<sup>141</sup>, as the value-added of the largest manufacturing sector in the current assessment is lower because it corresponds to 27 Member States (i.e. excluding UK), whereas in the 2017 assessment it was related to EU28.

## 14.7 Data sources

Data published by the Austrian Ministry for Sustainability and Tourism and the International Organising Committee for the World Mining Congress were used for the production at the extraction stage ('World Mining Data'). Statistical data for refined lithium production is not available. Information published by the German Minerals Resources Agency (DERA) for the year 2015 was used to approximate the global supply risk; therefore, the results for the global HHI of refined lithium production are not based on a 2012-2016 average, but only on the year 2015.

Trade data for refined lithium compounds were sourced from Eurostat's Comext database. Trade data for lithium concentrates are not available in the Harmonised System or in the Combined Nomenclature system of trade codes. The reason is that lithium ores and concentrates trade are reported in combination with other commodities under code HS 260790 for "Other ores and concentrates, not elsewhere specified". However, data concerning spodumene exports of Australia to the EU were provided by industry expert (for code HS 253090) after the SCRREEN workshop, and these were used in the

<sup>141</sup> The results are scaled by dividing the calculated EI score by the value of the largest manufacturing sector NACE Rev. 2 at the 2-digit level and multiplied by 10, in order to reach the value in the scale between 0-10.

assessment. EU exports were considered as non-existing, as it was assumed that all domestic production of ores and concentrates, as well as all imports, is consumed domestically. Trade data for lithium in other forms than lithium carbonate and hydroxide (e.g. Li chloride, Li bromide, butyllithium, lithium metal) are also not accounted separately by trade statistics; therefore, these compounds were not considered in the EU sourcing of refined lithium.

The EU MSA study of lithium published in 2015 was the source for the distribution of end use sectors and for the EOL-RIR.

## 14.7.1 Data sources used in the factsheet

Albemarle (2019) Albemarle Germany. Produkte der Spezialchemie, Producte. Available at: <https://www.albemarle.de/products> (Accessed: 28 August 2019).

Alves Dias, P. et al. (2018) Cobalt: demand-supply balances in the transition to electric mobility. doi: 10.2760/97710.

Alves Dias, P. (2018) 'European Commission. Joint Research Centre. Mission report. Seminar "Building the lithium value chain in Portugal". 27-6-2018'.

BGR (2017) BGR Energy Study. Available at: [https://www.bgr.bund.de/EN/Themen/Energie/Downloads/energiestudie\\_2017\\_en.pdf?\\_\\_blob=publicationFile&v=2](https://www.bgr.bund.de/EN/Themen/Energie/Downloads/energiestudie_2017_en.pdf?__blob=publicationFile&v=2).

BGS (2016) Mineral profile - Lithium. Available at: <http://www.bgs.ac.uk/mineralsuk/statistics/mineralProfiles.html>.

BGS (2019) World mineral statistics data, British Geological Survey. Available at: <https://www.bgs.ac.uk/mineralsuk/statistics/wms.cfc?method=searchWMS>.

BIO Intelligence Service (2015) Study on Data for a Raw Material System Analysis: Roadmap and Test of the Fully Operational MSA for Raw Materials. Available at: <https://ec.europa.eu/jrc/en/scientific-tool/msa>.

Blagoeva, D. et al. (2016) Assessment of potential bottlenecks along the materials supply chain for the future deployment of low-carbon energy and transport technologies in the EU. Wind power, photovoltaic and electric vehicles technologies, time frame: 2015-2030. doi: 10.2790/08169.

Bradley, D. C. et al. (2017) 'Lithium. U.S. Geological Survey Professional Paper 1802-K', in Schulz, K. J. et al. (eds) Critical Mineral Resources of the United States—Economic and Environmental Geology and Prospects for Future Supply. Available at: <https://doi.org/10.3133/pp1802>.

BRGM (2012) Panorama 2011 du marché du lithium, BRGM/RP-61340-FR. Available at: <http://www.mineralinfo.fr/page/monographie>.

BRGM (2017) 'Le lithium (Li) – éléments de criticité'. Bureau de Recherches Géologiques et Minières, pp. 1–8. Available at: <http://www.mineralinfo.fr/page/fiches-criticite>.

Bündnis Entwicklung Hilft (2019) WorldRiskIndex 2018. Available at: <https://weltrisikobericht.de/english-2/> (Accessed: 29 August 2019).

Bunsen, T. et al. (2019) Global EV Outlook 2019. Scaling-up the transition to electric mobility, Global EV Outlook. Available at: [www.iea.org/publications/reports/globalevoutlook2019/](http://www.iea.org/publications/reports/globalevoutlook2019/).

Christmann, P. et al. (2015) 'Global Lithium Resources and Sustainability Issues', in

- Chagnes, A. and Swiatowska, J. (eds) Lithium Process Chemistry: Resources, Extraction, Batteries, and Recycling. Elsevier, pp. 1–40. doi: 10.1016/b978-0-12-801417-2.00001-3.
- CRM validation workshop (2019) 'Statistics for spodumene exports from Australia to EU (HS 253090) provided by Vincent Pedailles'.
- CRU (2019) Lithium prices crash through \$10,000 as hype meets reality, CRU Insight. Available at: <https://www.crugroup.com/knowledge-and-insights/insights/2019/lithium-prices-crash-through-10-000-as-hype-meets-reality/> (Accessed: 8 September 2019).
- Dakota Minerals (2017) 'Largest Pegmatite-Hosted JORC Lithium Resource in Europe. 20-02-2017'.
- Draft lithium MSA (2019). Results of the lithium MSA Study. Internal document – not published. Reference date: 02 December 2019.
- DERA (2017) 'Chart des Monats, März 2017. Starker Preisanstieg von Kobalt und Lithium'. Available at: [https://www.deutsche-rohstoffagentur.de/DERA/DE/Publikationen/Chart\\_des\\_Monats/cdm\\_node.html](https://www.deutsche-rohstoffagentur.de/DERA/DE/Publikationen/Chart_des_Monats/cdm_node.html).
- DERA (2018) 'Chart des Monats, Dezember 2018. Hohe Preisdynamik im Lithiummarkt'. Available at: [https://www.deutsche-rohstoffagentur.de/DERA/DE/Publikationen/Chart\\_des\\_Monats/cdm\\_node.html](https://www.deutsche-rohstoffagentur.de/DERA/DE/Publikationen/Chart_des_Monats/cdm_node.html).
- Deutsche Lithium GmbH (2018) Zinnwald Lithium Project. Report on the Mineral Resource. Available at: <http://www.bacanoralithium.com/investor-relations/technical-reports/>.
- Deutsche Lithium GmbH (2019) Technical Report on the Feasibility Study for the Zinnwald Lithium Project, Germany. Available at: <http://www.bacanoralithium.com/investor-relations/technical-reports/>.
- Dinis P. and Horgan S (2018) 'Informação Estatística sobre Produção de Recursos Minerais contendo Lítio. Evolução no Período de 1998 a 2017', in Direção-Geral de Energia e Geologia (DGEG) (ed.) Boletim de Minas. Direção-Geral de Energia e Geologia (DGEG), pp. 125–135. Available at: <http://www.dgeg.gov.pt/pagina.aspx?f=1&lws=1&mcna=0&inc=AAAAAAAAAAAAAAAAAAAAAAAAAAAA&parceiroid=0&codigoms=0&codigono=689170547485AAAAAAAAAAAAA> A.
- Duesenfeld (2019) Recycling lithium-ion batteries efficiently. Available at: <https://www.duesenfeld.com/efficiency.html> (Accessed: 3 September 2019).
- ECHA (2019) Substances restricted under REACH, European Chemicals Agency. Information on Chemicals. Available at: [https://echa.europa.eu/substances-restricted-under-reach?p\\_p\\_id=dislists\\_WAR\\_dislistsportlet&p\\_p\\_lifecycle=1&p\\_p\\_state=normal&p\\_p\\_mode=view&p\\_p\\_col\\_id=column-1&p\\_p\\_col\\_pos=1&p\\_p\\_col\\_count=2&\\_dislists\\_WAR\\_dislistsportlet\\_javax.portlet.action=searchDiss](https://echa.europa.eu/substances-restricted-under-reach?p_p_id=dislists_WAR_dislistsportlet&p_p_lifecycle=1&p_p_state=normal&p_p_mode=view&p_p_col_id=column-1&p_p_col_pos=1&p_p_col_count=2&_dislists_WAR_dislistsportlet_javax.portlet.action=searchDiss) (Accessed: 22 August 2019).
- ESTAT Comext (2019) Easy Comext database. Available at: <http://epp.eurostat.ec.europa.eu/newxtweb/>.
- European Commission (2011) Critical raw materials. Available at: [https://ec.europa.eu/growth/sectors/raw-materials/specific-interest/critical\\_en](https://ec.europa.eu/growth/sectors/raw-materials/specific-interest/critical_en) (Accessed: 8 July 2019).
- European Commission (2014) Report on critical raw materials for the EU. Non-Critical Raw Materials Profiles.
- European Commission (2017) Study on the review of the list of critical raw materials. Non-

- Critical Raw Materials Factsheets. European Commission. doi: 10.2873/876644.
- European Commission (2018) Commission Staff Working Document SWD(2018) 245/2 final, 22.11.2018. Materials for Battery Applications. Available at: <https://ec.europa.eu/transport/sites/transport/files/3rd-mobility-pack/swd20180245.pdf>.
- European Commission (2019) Negotiations and agreements. Available at: <http://ec.europa.eu/trade/policy/countries-and-regions/negotiations-and-agreements/> (Accessed: 7 July 2019).
- European Lithium Ltd (2018) 'European Lithium completes positive PFS. 5-4-2018'. Available at: <https://europeanlithium.com/announcements>.
- European Metals Ltd (2017a) 'Cinovec Maiden Ore Reserve – Further Information. 04-07-2017'. Available at: <https://www.europeanmet.com/announcements/>.
- European Metals Ltd (2017b) 'Further Increase in Indicated Resource at Cinovec South. 28-11-2017'. Available at: <https://www.europeanmet.com/announcements/>.
- Eurostat (2019) Annual detailed enterprise statistics for industry (NACE Rev. 2, B-E). Available at: [https://ec.europa.eu/eurostat/en/web/products-datasets/-/SBS\\_NA\\_IND\\_R2](https://ec.europa.eu/eurostat/en/web/products-datasets/-/SBS_NA_IND_R2) (Accessed: 7 July 2019).
- Evans, K. (2014) 'Lithium', in Gunn, G. (ed.) Critical Metals Handbook. British Geological Survey, John Wiley & Sons, American Geophysical Union, pp. 232–258.
- Fastmarkets MB (2019) Lithium's volatile evolution prompts companies to rethink how best to trade. Available at: <https://www.metalbulletin.com/Article/3885488/FOCUS-Lithiums-volatile-evolution-prompts-companies-to-rethink-how-best-to-trade.html> (Accessed: 5 September 2019).
- Ferg, E. E., Schuldt, F. and Schmidt, J. (2019) 'The challenges of a Li-ion starter lighting and ignition battery : A review from cradle to grave', Journal of Power Sources. Elsevier, 423(March), pp. 380–403. doi: 10.1016/j.jpowsour.2019.03.063.
- FODD (2017) Fennoscandian Mineral Deposits, Fennoscandian Ore Deposit database. V.2017. Available at: <http://en.gtk.fi/information-services/databases/fodd/index.html> (Accessed: 9 August 2019).
- Gautneb, H. et al. (2019) 'Occurrences of energy critical elements; Lithium – Cobalt and Graphite in Europe, a preliminary overview', SGA 2019 - 15th Biennial Meeting of the Society for Geology Applied to Mineral Deposits. Glasgow, United Kingdom. doi: 10.1016/j.oregeorev.2019.04.015.
- Gloaguen, E. et al. (2018) Ressources métropolitaines en lithium et analyse du potentiel par méthodes de prédictivité. BRGM/RP-68321-FR.
- Global Trade Alert (2018) Argentina: Government sets new export duties. Available at: <https://www.globaltradealert.org/state-act/31905/argentina-government-sets-new-export-duties> (Accessed: 28 August 2019).
- Graedel, T. et al. (2015a) 'On the materials basis of modern society', Proceedings of the National Academy of Sciences, 112(20). doi: 10.1073/pnas.1312752110.
- Graedel, T. et al. (2015b) 'On the materials basis of modern society. Supporting information file', Proceedings of the National Academy of Sciences of the United States of America. National Academy of Sciences, pp. 6295–300. doi: 10.1073/pnas.1312752110.
- Hagelüken, C. (2018) Recycling of Li-Ion Batteries - imperative for sustainable e-mobility.
- Harvey, D. (2018) 'Resource implications of alternative strategies for achieving zero greenhouse gas emissions from light-duty vehicles by 2060', Applied Energy. Elsevier,

- 212(August 2017), pp. 663–679. doi: 10.1016/j.apenergy.2017.11.074.
- Hocking, M. et al. (2016) Deutsche Bank. Market Research. Lithium 101: welcome to the Lithium age. Available at: <http://www.belmontresources.com/LithiumReport.pdf>.
- Infinity Lithium Ltd (2018) 'Lithium resource and geotechnical upgrade. 23-05-2018', p. 2018. Available at: <https://www.infinitylithium.com/asx-announcements>.
- Keliber Oy (2018) Lithium Project. Definitive Feasibility Study–Executive Summary. 14-6-2018. Available at: <https://www.keliber.fi/en/investors/definitive-feasibility-study>.
- Keliber Oy (2019) Updated Definitive Feasibility Study–Executive Summary.
- Lebedeva, N., Di Persio, F. and Boon-Brett, L. (2017) Lithium-ion battery value chain and related opportunities for Europe, JRC 105010. doi: 10.2760/75757.
- Lepidico Ltd (2019) '210 % increase in contained lithium at Alvarrões. 11-04-2019'. Available at: <http://www.lepidico.com/investors/announcements/>.
- Lithium Australia (2017) 'Maiden lithium Mineral Resource estimate for Sadisdorf project. 7-12-2017'. Available at: <https://lithium-au.com/announcements/#tab-id-2>.
- Lithium Working Group (2017) Report of the Lithium Working Group.
- Marscheider-Weidemann, F. et al. (2016) Rohstoffe für Zukunftstechnologien 2016 - DERA Rohstoffinformationen 28. Edited by D. R. (DERA) in Der and B. für G. und R. (BGR). Berlin.
- Minerals4EU (2019) European Minerals Yearbook. Available at: [http://minerals4eu.brgm-rec.fr/m4eu-yearbook/theme\\_selection.html](http://minerals4eu.brgm-rec.fr/m4eu-yearbook/theme_selection.html).
- Nogueira, C. (2017) 'Lithium Recovery from Primary and Secondary Resources', 22nd ICBR - International Congress on Battery Recycling, 0(session 2).
- OECD (2019) Export Restrictions on Industrial Raw Materials. Available at: [https://qdd.oecd.org/subject.aspx?Subject=ExportRestrictions\\_IndustrialRawMaterials](https://qdd.oecd.org/subject.aspx?Subject=ExportRestrictions_IndustrialRawMaterials) (Accessed: 5 July 2019).
- PANNN (2017) Estudo De Impacte Ambiental. Mina da Argemela. Available at: [http://siaia.apambiente.pt/AIADOC/DA201/pda\\_201\\_mina\\_argemela201811212231.pdf](http://siaia.apambiente.pt/AIADOC/DA201/pda_201_mina_argemela201811212231.pdf).
- Peterson, B. (2017) 'Fluxes for Ceramics and Glaze'. Available at: <https://www.thesprucecrafts.com/ceramic-and-glaze-fluxes-2745860> (Accessed: 27 August 2019).
- ProSum (2019) Datasets of the Urban Mine Platform. Available at: <http://www.urbanmineplatform.eu/homepage>.
- Recharge (2018) The Batteries Report 2018. Available at: <https://www.rechargebatteries.org/the-recharge-batteries-report-2018-is-online/>.
- Regueiro y González-Barros, M. (2016) Ceramic Raw Materials in Spain. doi: 10.13140/RG.2.2.30444.77449.
- Reichl, C., Schatz, M. and Zsak, G. (2019) World Mining Data 2019. Volume 33. Available at: [www.bmnt.gv.at](http://www.bmnt.gv.at).
- Rio Tinto (2017) 'Notice to ASX Increase to Jadar Project Mineral Resources', (March). Available at: [https://www.riotinto.com/documents/170302\\_Increase\\_to\\_Jadar\\_Project\\_Mineral\\_Resources.pdf](https://www.riotinto.com/documents/170302_Increase_to_Jadar_Project_Mineral_Resources.pdf).
- Rio Tinto (2018) 'Jadar Project fact sheet'. Available at: [www.riotinto.com/Jadar](http://www.riotinto.com/Jadar).



- Roskill (2019) Lithium-ion Batteries: Outlook to 2028, 3rd Edition.
- Rudnick, R. L. and Gao, S. (2014) Composition of the Continental Crust, Treatise on Geochemistry: Second Edition. Elsevier Ltd. doi: 10.1016/B978-0-08-095975-7.00301-6.
- S&P Global Market Intelligence (2019a) Lithium Commodity profile. Metals and Mining properties, Market Intelligence Platform. Available at: <https://www.spglobal.com/marketintelligence/en/> (Accessed: 29 August 2019).
- S&P Global Market Intelligence (2019b) Lithium Commodity profile. Price charts, Market Intelligence Platform. Available at: <https://www.spglobal.com/marketintelligence/en/> (Accessed: 29 August 2019).
- Saruls, R. (2017) 'Impacts and Trends On The Grease Industry Roberto Saruls-Lubrizol Brazil'. Available at: <http://www.boweryboyshistory.com/wp-content/uploads/2013/03/7.jpg> (Accessed: 27 August 2019).
- Savannah Resources Plc (2019a) 'Mineral Resource Increase of 17% to 23.5 Mt at Mina do Barroso Lithium Project. 09-04-2019'. Available at: <http://www.savannahresources.com/news-items/>.
- Savannah Resources Plc (2019b) 'Mineral Resource Increase to 27 Mt at Mina do Barroso Lithium Project. 31-05-2019'. Available at: <http://www.savannahresources.com/news-items/>.
- Schmidt, M. (2017) Rohstoffrisikobewertung – Lithium. DERA Rohstoffinformationen 33. Berlin. Available at: [https://www.deutsche-rohstoffagentur.de/DERA/DE/Aktuelles/rohstoff\\_lithium.html](https://www.deutsche-rohstoffagentur.de/DERA/DE/Aktuelles/rohstoff_lithium.html).
- Tercero, L. et al. (2015) Critical Raw Materials Substitution Profiles, CRM \_Innonet. Available at: [http://publica.fraunhofer.de/eprints/urn\\_nbn\\_de\\_0011-n-4455718.pdf](http://publica.fraunhofer.de/eprints/urn_nbn_de_0011-n-4455718.pdf).
- UN Comtrade (2019) International Trade Statistics Database. Available at: <https://comtrade.un.org/> (Accessed: 8 July 2019).
- USGS (2017) 'Historical Statistics for Mineral and Material Commodities in the United States - Lithium'. U.S. Geological Survey. Available at: <https://www.usgs.gov/centers/nmic/historical-statistics-mineral-and-material-commodities-united-states#boron> (Accessed: 30 August 2019).
- USGS (2018) 2016 Minerals Yearbook - Lithium. Available at: <https://minerals.usgs.gov/minerals/pubs/commodity/lithium/myb1-2016-lithi.pdf>.
- USGS (2019) Mineral Commodity Summaries 2019. U.S Geological Survey. doi: 10.1007/978-3-540-47108-0-4.
- Vulcan Energy Resources (2019) 'Vulcan Energy Resources Ltd. Largest JORC Lithium Resource in Europe'.4-12-2019. Available at: <https://v-er.com/investor-centre/asx-announcements/>.
- World Bank (2018) Aggregate Governance Indicators 1996-2017, Worldwide Governance Indicators. Available at: <http://info.worldbank.org/governance/WGI/#home> (Accessed: 7 July 2019).
- World Resources Institute (2019) Water Risk Index. Available at: <https://www.wri.org/aqueduct> (Accessed: 29 August 2019).

## 14.7.2 Data sources used in the criticality assessment

WMD (2019) World Mining Data 2019, Reichl, C.; Schatz, M; Zsak, G. Iron and Ferro Alloy Metals, non Ferrous Metals, Precious Metals, Industrial Minerals, Mineral Fuels. Austrian Federal Ministry of Sustainability and Tourism. [online] Available at: [www.en.bmwf.gv.at/Energy/WorldMiningData/Seiten/default.aspx](http://www.en.bmwf.gv.at/Energy/WorldMiningData/Seiten/default.aspx)

Schmidt, M. (2017) *Rohstoffrisikobewertung – Lithium*. DERA Rohstoffinformationen 33. Berlin. Available at: [https://www.deutsche-rohstoffagentur.de/DERA/DE/Aktuelles/rohstoff\\_lithium.html](https://www.deutsche-rohstoffagentur.de/DERA/DE/Aktuelles/rohstoff_lithium.html).

ESTAT Comext (2019) *Easy Comext database*. Available at: <http://epp.eurostat.ec.europa.eu/newxtweb/>.

CRM validation workshop (2019) 'Statistics for spodumene exports from Australia to EU (HS 253090) provided by Vincent Pedailles'.

BIO Intelligence Service (2015) *Study on Data for a Raw Material System Analysis: Roadmap and Test of the Fully Operational MSA for Raw Materials*. Available at: <https://ec.europa.eu/jrc/en/scientific-tool/msa>.

Draft lithium MSA (2019). Results of the lithium MSA Study. Internal document – not published. Reference date: 02 December 2019

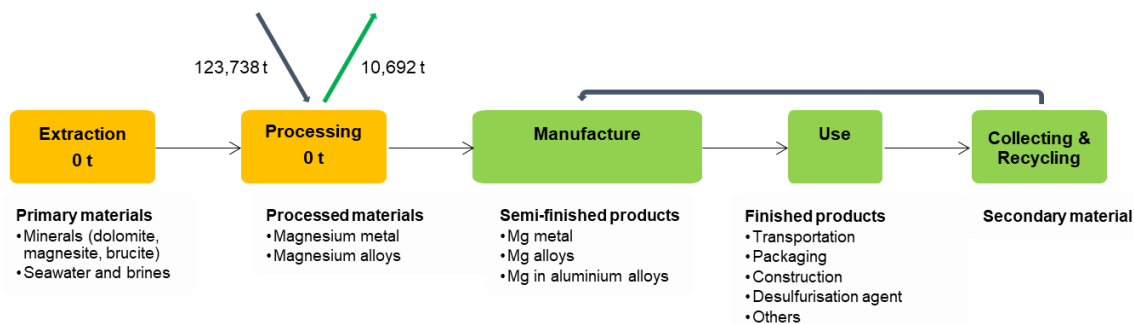
## 14.8 Acknowledgements

---

This factsheet was prepared by the JRC. The authors would like to thank the Ad Hoc Working Group on Critical Raw Materials, as well as experts participating in SCREEN workshops for their contribution and feedback, such as Mr Vincent Pedailles (Infinity Lithium), Mr Eric Gloaguen (BRGM), Mr Corina Hebestreit (Euromines), Mr Peter Buchholz (DERA), Mr Henryk Karas Mr Claude Chanson (Recharge) and others.

# 15 MAGNESIUM

## 15.1 Overview

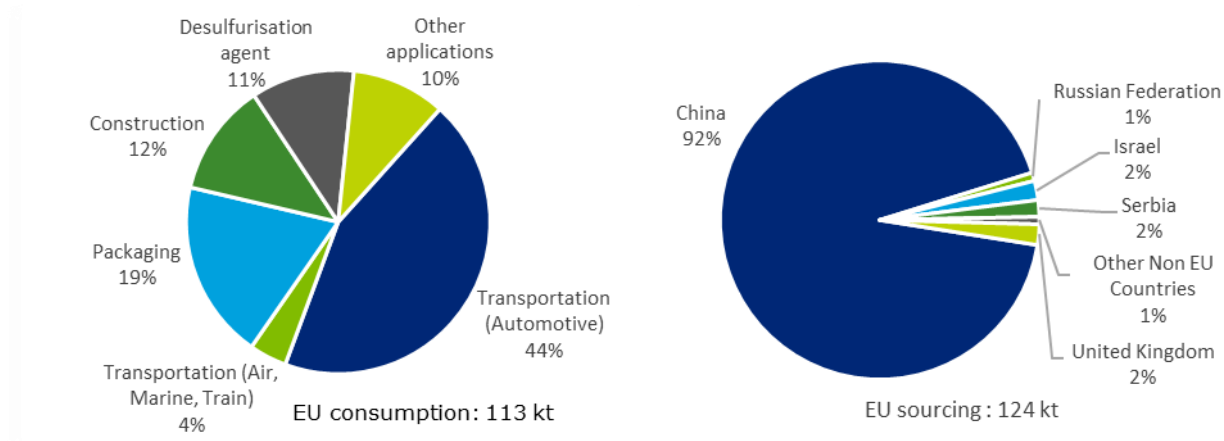


**Figure 186: Simplified value chain for magnesium<sup>142</sup> for the EU, averaged over 2012-2016**

Magnesium (chemical symbol Mg) is the eighth most abundant element in the Earth’s crust (2.1% in weight) and the third most abundant element in solution in seawater. Magnesium is a metal which does not occur in its elemental form in nature, but is found in different forms in minerals (dolomite, magnesite, carnallite) as well as in seawater and brines. Although seawater was a major source of magnesium during the second half of the twentieth century, closure of seawater magnesium plants and increase in output from China led to a magnesium supply now dominated by mineral sources. Magnesium is the lightest of all commonly used structural materials.

Magnesium is commercialised under the form of pure metal or as casting alloys. The former may be used as such, for instance in the steel industry (as a desulfurization agent), or in aluminium alloys.

The trade codes used in this assessment are CN 81041100 (99.8% Mg contained) and CN 81041900 (90% Mg contained) (Eurostat Comext, 2019).



**Figure 187: End uses (IMA-Europe, 2019) and EU sourcing (BGS, 2019; Eurostat, 2019) of magnesium (metal), 2012-16.**

.JRC elaboration on multiple sources (see next sections)

There is no production of pure magnesium in the EU: the supply for the manufacturing industry entirely relies on imports from China and a few other non-EU countries (Israel, Russia, and Turkey). The EU apparent consumption of magnesium represents around 15% of the consumption worldwide<sup>143</sup>.

After a price hike in 2008, magnesium prices remained more stable, and gradually decreased down to US\$ 2.5/kg in 2018 (CM Group, 2019).

The EU consumption of magnesium was 113 kt (annual average in 2012-2016) and was 184 kt in 2018, which are entirely sourced through imports, mainly from China (92%). United Kingdom, Serbia and Israel contribute with the 2% of the EU sourcing, while Russian Federation and USA each supply to the EU is below 2% of the total. Import reliance is 100%.

Magnesium metal is used in aluminium alloys (39% in the EU) and magnesium alloys (40% in the EU) for its lightness, in a variety of industry sectors including transports, packaging and construction. Other applications include steel industry, as well as pharmaceutical and agricultural chemical production.

According to USGS (2019), as magnesium metal is derived from natural brines, dolomite, serpentine, and other minerals, magnesium reserves are sufficient to supply current and future requirements. Resources are also considered as virtually unlimited and globally widespread.

For Europe, there is no complete and harmonised dataset that presents total EU resource and reserve estimates for magnesium. Minerals4EU (2019) is the only EU-level repository of some mineral resource and reserve data for magnesium, but this information does not provide a complete picture for Europe. It includes estimates based on a variety of reporting codes used by different countries, and different types of non-comparable datasets (e.g. historic estimates, inferred reserves figures only, etc.).

The world production of magnesium metal is about 928,000 tonnes annually<sup>144</sup>, with 89% produced in China and 4% in the US (average 2012-2016). There is no production of magnesium metal in the EU.

Secondary magnesium is an important component in global magnesium supply, with production estimated<sup>145</sup> at 265 kt, of which 45% is located in the US (DERA Mg workshop 2019). In the EU, the EoL-RIR (End-of-Life Recycling Input Rate) for magnesium is assessed at around 13%.

EU has an import quota for both magnesium metal (80,000 tonnes starting January 1<sup>st</sup> 2017 suspended mid-2019 and expanded to 120,000 tonnes as of 2020<sup>146</sup>) and magnesium powder (2,000 tonnes<sup>147</sup>).

---

<sup>143</sup> 20% considering the 4 digit code 8104; 15% considering the sum of 6 digit codes 810411 and 810419

<sup>144</sup> 943kt according to CM Group IMA Budapest 2019

<sup>145</sup> Estimated capacity

<sup>146</sup> [https://ec.europa.eu/taxation\\_customs/dds2/taric/quota\\_consultation.jsp?Lang=en&Origin=&Code=092722&Year=2019&Year=2018&Critical=&Status=&Expand=true](https://ec.europa.eu/taxation_customs/dds2/taric/quota_consultation.jsp?Lang=en&Origin=&Code=092722&Year=2019&Year=2018&Critical=&Status=&Expand=true)

<sup>147</sup> [https://ec.europa.eu/taxation\\_customs/dds2/taric/quota\\_consultation.jsp?Lang=de&Origin=&Code=092840&Year=2019&Year=2018&Year=2017&Critical=&Status=&Expand=true](https://ec.europa.eu/taxation_customs/dds2/taric/quota_consultation.jsp?Lang=de&Origin=&Code=092840&Year=2019&Year=2018&Year=2017&Critical=&Status=&Expand=true)

## 15.2 Market analysis, trade and prices

---

### 15.2.1 Global market analysis and outlook

Global growth in the magnesium demand in the short term is expected to average 4,9% per year reaching almost 1,100 kt per year by 2020<sup>148</sup>. Aluminium alloys (10y CAGR<sup>149</sup> 4,1%) and magnesium die casting (10y CAGR 6,8%) are predicted to be the fastest growing markets. Transportation will probably be the main applications affecting magnesium demand because of greater unit consumption and increased vehicle production.

Worldwide demand is expected to increase at a CAGR of 6.8% in the next decade (CM Group 2019). In particular, the development of R&D technologies could significantly impact the long-term demand for magnesium, such as: incorporation of nanoparticles in magnesium alloys to improve its properties (e.g. strength, stiffness, plasticity and high temperature stability) and magnesium-ion rechargeable batteries (with twice the capacity and energy density of lithium-ion batteries) (International Mining, 2016). The commercial introduction of new manufacturing processes (3D printing, Mg wrought products profiles and sheets) will also impact future growth of magnesium (IMA 2019).

On the supply side, leading players in the magnesium metal market are expected to continue expanding in the coming years, for instance in China, US<sup>150</sup> and Turkey<sup>151</sup>. In China, the consolidation of the mining sector is continuing, the number of plants will be reduced, but producing plants will become bigger (BGR, 2019). New projects are under progress, for instance Qinghai Salt Lake in China – initially due on stream in 2017 (100 kt/y as first stage), is only ramping-up its production slowly. Other planned projects aiming at production before 2020<sup>152</sup> include Alliance Magnesium in Canada (50 kt/y); Latrobe in Australia (40 kt/y) (IMA 2019).

Overall, it is expected that global primary capacity will expand in line with over 42% of underutilised capacity in China and other Western smelters expanding capacity or creating new plants (IMA, 2017). Dead Sea Magnesium in Israel is a high cost producer with capacity for 35 kt/y.

Regarding magnesium prices after 2017, no major change is expected assuming continuation of stable supply from China. Therefore, magnesium prices will probably remain in the US\$ 2 to US\$ 3/kg range (IMA, 2019).

Estimations for the outlook for supply and demand of magnesium are shown in Table 82. Environmental and legislative influences are expected to promote the use of magnesium compared to steel and aluminium. As lightweight and fuel-efficient vehicles gain centre stage in the automotive landscape, magnesium is gaining traction as a preferred manufacturing material (Future Market Insights, 2016; SCRREEN workshops, 2019).

---

<sup>148</sup> CM Group Base 2018 975 Mt, CAGR 4,9%

<sup>149</sup> CAGR: Compound Annual Growth Rate

<sup>150</sup> Expansion in US and Turkey might be on hold. Little information about China.

<sup>151</sup> According to BGR (2019), in 2019 Turkey is back by producing some thousand tonnes. KAR Mineral Madencilik is now the producer at Cifteler. <https://www.karmadencilik.com.tr/en>.

<sup>152</sup> Both projects are at least delayed for 2022.

Alliance: “ This first phase will be followed by a 50,000 ton commercialization plant, whose construction is planned for 2022”

<http://alliancemagnesium.com/news/>

Latrobe: “Start construction in Feb 2020 ☐ Commence production at 3,000tpa in July 2021 ☐ Start construction of 40,000tpa ~12 months later”

<https://latrobemagnesium.com/wp-content/uploads/19-12-05-Community-Briefing.pdf>

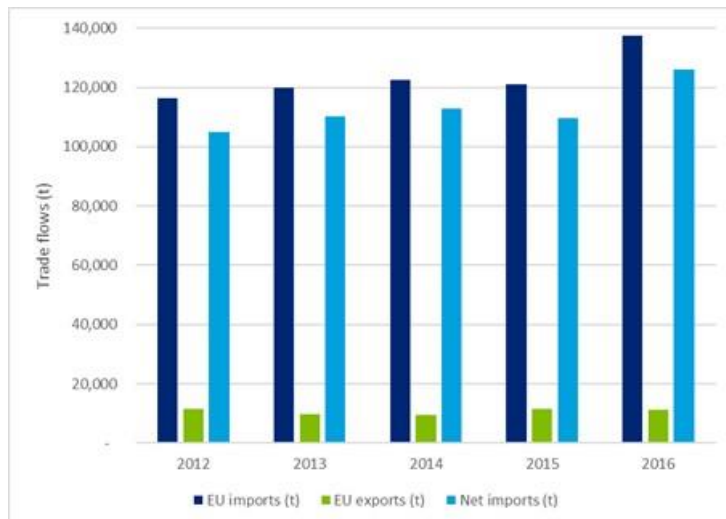
**Table 82: Qualitative forecast of supply and demand of magnesium**

Materials	Criticality of the material in 2020		Demand forecast			Supply forecast		
	Yes	No	5 years	10 years	20 years	5 years	10 years	20 years
Magnesium	X		+	+	+	+	+	+

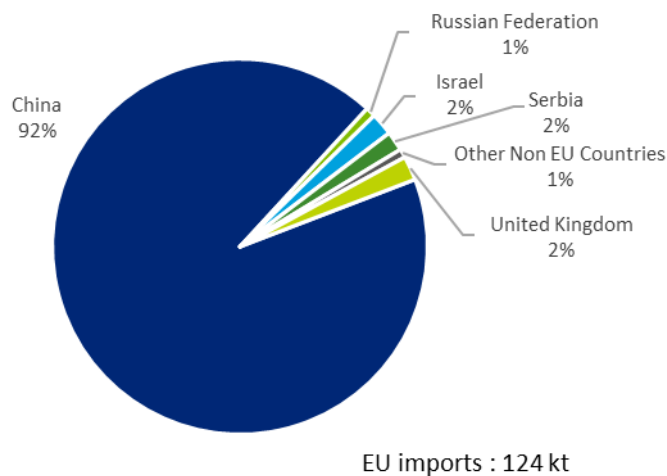
**15.2.2EU trade**

With no primary extraction of magnesium, the EU supply entirely relies on imports of primary magnesium. As well as on processing new scrap (pre-consumer or processing scrap) and production of secondary magnesium (from post-consumer recycling) although less significantly.

The average annual net import figure in the period 2012-2016 was of 124 kt (Figure 188). The main supplier of the EU is China, with 92% of the imports to the EU - which is consistent with China being the largest worldwide producer. The Chinese prevalence in EU imports started in the past decade: in 2000, only 27% of EU magnesium imports originated from China, behind Norway the main supplier to the EU (36% of imports in the same year). Norway production of primary magnesium stopped since then.



**Figure 188: EU trade flows for magnesium (Eurostat, 2019b)**



**Figure 189: EU imports of magnesium. Average 2012-2016 (Eurostat 2019c)**

Imports of magnesium to the EU increased regularly until 2007, with a 7% annual rise between 2000 and 2007. In 2009, EU trade of magnesium with extra-EU countries collapsed mainly due to reduced primary magnesium production. From 2010 to 2014, EU trade remained stable. EU imports increased by 13% from 2015 to 2016. Around 57% of magnesium imports in 2015 are under the form of pure metal ('Unwrought magnesium, containing  $\geq 99.8\%$  by weight of magnesium'); the rest is under the form of magnesium alloys ('Unwrought magnesium, containing  $< 99.8\%$  by weight of magnesium'). The breakdown remained similar in the past years. The Eurostat statistics partly include magnesium processed from secondary material (e.g. imports from Serbia, since there is no primary magnesium production in the country); once processed, there is no distinction between primary and secondary magnesium.

Exports of magnesium from the EU are not significant compared to imported volumes, with an average of 10.7 kt/y over the 2012-2016 period. Most of exported volumes are under the form of magnesium scrap. Major destinations for exported magnesium scrap are the United States (40% in 2018) and Brazil (21% in 2018).

Since 2013, there is no restriction on commercial trade of magnesium metal and magnesium alloys (i.e. no export tax, export quota or export prohibition of magnesium from extra-EU countries) with the EU Member States. With the exception of an import quota for both magnesium metal (80 kt starting January 1st 2017 suspended mid-2019 and expanded to 120 kt as of 2020<sup>153</sup>) and magnesium powder (2 kt<sup>154</sup>). Until end of 2012, China had established a 10% tax on magnesium exports from the country. In July 2011, the WTO ruled that China violated global rules by restricting exports of nine materials including magnesium, thus leading to the removal of the tax.

The EU trade of magnesium scrap is not included in the factsheet due to data availability and data quality issues, however large volumes are traded to US companies as source of low-cost metal. The US anti-dumping duties on Chinese magnesium causes price differential between the two markets (IMA, 2017). Export restrictions apply to magnesium waste and scrap imports to the EU. There are export taxes in Argentina (5%), Jordan (5%), Morocco (7.5%), Russia (20%), Vietnam (22%) and Zambia (25%) . There is an export prohibition in Burundi, Kenya and Rwanda. Licensing requirements apply in many countries, for magnesium waste and scrap as well as unwrought magnesium (OECD, 2019).

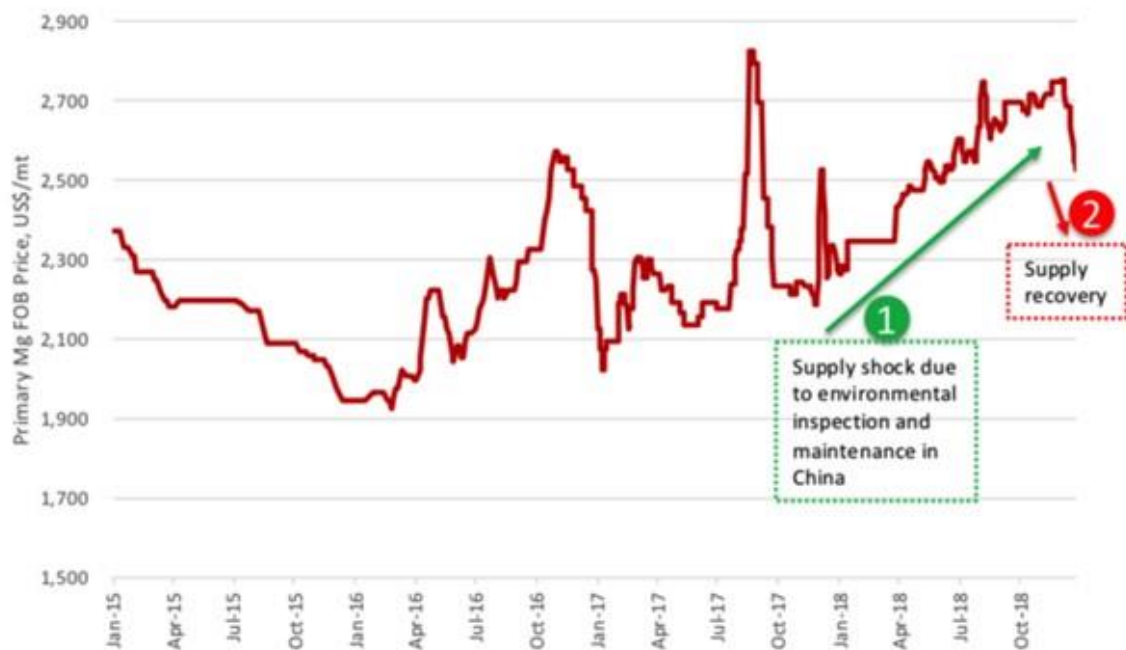
### **15.2.3 Prices and price volatility**

Prices for magnesium metal are primarily cost driven, reflecting supply overcapacity (particularly in China). In 2008, magnesium plants were shut down for environmental concerns during Beijing Olympics game, which led to a price hike on the global market up to US\$ 6 per kilogram of metal since China is the major supplier of magnesium worldwide (IMA, 2017).

---

<sup>153</sup> [https://ec.europa.eu/taxation\\_customs/dds2/taric/quota\\_consultation.jsp?Lang=en&Origin=&Code=092722&Year=2019&Year=2018&Critical=&Status=&Expand=true](https://ec.europa.eu/taxation_customs/dds2/taric/quota_consultation.jsp?Lang=en&Origin=&Code=092722&Year=2019&Year=2018&Critical=&Status=&Expand=true)

<sup>154</sup> [https://ec.europa.eu/taxation\\_customs/dds2/taric/quota\\_consultation.jsp?Lang=de&Origin=&Code=092840&Year=2019&Year=2018&Year=2017&Critical=&Status=&Expand=true](https://ec.europa.eu/taxation_customs/dds2/taric/quota_consultation.jsp?Lang=de&Origin=&Code=092840&Year=2019&Year=2018&Year=2017&Critical=&Status=&Expand=true)



**Figure 190: Magnesium metal prices in US\$/t, 2015-2018. (CM Group, 2019)**

Since 2008, magnesium prices remained more stable, and gradually decreased down to US\$ 2 per kilogram until the first quarter of 2016. As prices moved below this level at the end of 2015, resistance from producers coupled with firming coal prices and better than expected performance in the Chinese economy pushed the price of magnesium up by 11% in April 2016 (International Mining, 2016).

There is an antidumping-duty in the US for magnesium from China, therefore the price of magnesium metal is higher in the US compared to the EU<sup>155</sup>.

## 15.3 EU demand

### 15.3.1 EU consumption

The EU apparent consumption of magnesium is calculated at about 113 kt per year of processed material. Almost all of magnesium is imported in the EU as pure magnesium or magnesium alloys; swarf, granules and powders represent gross volumes of about 14 kt (IMA, 2017).

Magnesium casting alloys and aluminium alloys represent respectively 43% and 39% of magnesium use in the EU over the 2010-2014 period. It can be considered that the majority of magnesium alloys are used in transportation applications<sup>156</sup>; some castings are alloyed with rare earth elements to improve creep and corrosion resistance (International Mining, 2016).

Aluminium alloys are used in packaging, transportation and construction sector. Magnesium is present in aluminium alloys in distinct proportions: transportation aluminium alloys contain around 1% of magnesium, while there is around 2% of magnesium in packaging and 0.5% in construction aluminium alloys. Magnesium as alloying element is essential for the aluminium industry (IMA, 2019).

<sup>155</sup> antidumpingpublishing.com, 2017

<sup>156</sup> Also other applications like Power tools could be mentioned.



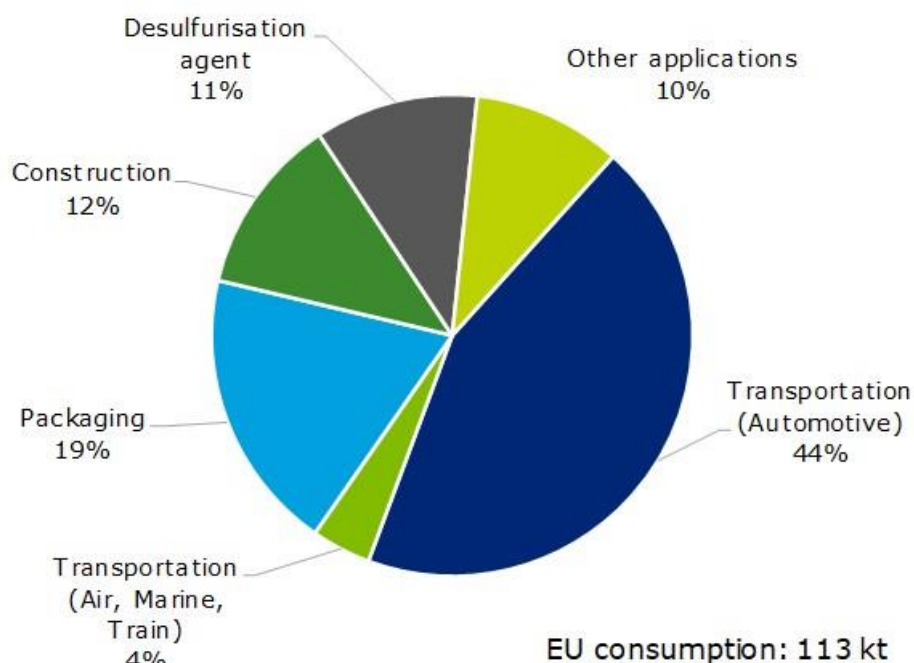
### 15.3.2 Uses and end-uses of magnesium in the EU

The major end-uses of magnesium in the EU are in the transportation sector. In addition, magnesium in aluminium alloys is used in packaging and construction. Magnesium is also used in non-structural applications such as desulfurization agent (European Commission, 2014b; IMA, 2019; SCRREEN workshops, 2019):

- Automotive industry: Magnesium casting alloys is mainly used in vehicles to lower the overall weight, e.g. in replacement of steel or aluminium. Magnesium is used in many vehicle parts from gearbox, steering column and driver's airbag housings to steering wheels, seat frames and fuel tank covers. The use of magnesium as one single cast piece in vehicles may also increase the strength of the material compared to various steel components.  
In addition to being used in terrestrial vehicles such as cars, vans and trucks, magnesium is also used in trains and aerospace applications both civil and military: for instance, in thrust reversers, as well as in engines and transmission casings of aircrafts and helicopters. Spacecraft and missiles also contain magnesium as it is capable of withstanding exposure to ozone and impact of high energy particles and matter (IMA, 2016).
- Desulphurisation of steel: Due to its high affinity for sulphur, magnesium is injected in molten iron or steel to reduce the sulphur content. The process prevents sulphur from damaging steel as it causes brittleness in steel; low sulphur facilitates modern production processes (IMA, 2019; International Mining, 2016).
- Packaging applications represent 35% of magnesium use in aluminium alloys (IMA, 2019). Magnesium improves aluminium strength without removing the material workability. In addition to aluminium beverage can, magnesium is also used in aluminium alloys in food cans and trays. Further detail may be found in the aluminium factsheet.
- Construction equipment: Magnesium in aluminium alloys is used for doors, windows, cladding, roofing, staircases, air conditioning units, among other components. Further detail may be found in the aluminium factsheet.
- Other uses: Medical applications, sport applications, among others. Magnesium can be used in electrochemical applications: magnesium anodes prevent from galvanic corrosion of steel. It is also used in industrial synthesis such as the Grignard reaction in organic chemistry applications (IMA, 2019).

Magnesium alloys are used in small and portable electronic applications such as camera, cell phone and laptop for its lightness combined to strength and durability, e.g. in replacement of plastics. Many electronics require parts or casings with complex shapes which are possible with magnesium. The use of magnesium in electronic applications manufacturing is not significant in the EU (IMA, 2017). Finally, magnesium is used as a reducing agent in the production of beryllium, titanium, etc. – although not in the EU since there is no titanium or beryllium production.

The end-use shares provided in Figure 191 were calculated based on existing studies and stakeholders' feedback (IMA, 2017; IMA, 2019) and relevant industry sectors are described using the NACE sector codes in Table 83.



**Figure 191: Global end uses of magnesium, 2012-2016 (IMA, 2019)**

**Table 83: Magnesium applications, 2-digit and associated 4-digit NACE sectors, and value added per sector. (IMA, 2019; Eurostat, 2019a)**

Applications	2-digit NACE sector	Value added of 2 NACE sector (M€)	4-digit NACE sectors
Transportation	C29 - Manufacture of motor vehicles, trailers and semi-trailers C30 - Manufacture of other transport equipment	160,603 / 44,304	C2910 - Manufacture of motor vehicles; C2920 - Manufacture of bodies for motor vehicles; C2932 - Other parts for motor vehicles; C3030 - Manufacture of air and spacecraft; C3011 - Building of ships and floating structures; C3020 - Manufacture of railway locomotives and rolling stock; C3092 - Manufacture of bicycles
Packaging	C25 - Manufacture of fabricated metal products, except machinery and equipment	148,351	C2592 - Manufacture of light metal packaging
Construction	C25 - Manufacture of fabricated metal products, except machinery and equipment	148,351	C2511 - Manufacture of metal structures and parts of structures; C2512 - Manufacture of doors and windows of metal; C2599 - Manufacture of other fabricated metal products n.e.c.
Desulphurisation agent	C24 - Manufacture of basic metals	55,426	2410 - Manufacture of basic iron and steel and of ferro-alloys

### **15.3.3 Substitution**

All the identified applications have been considered in the assessment (IMA, 2017; IMA, 2019; SCRREEN workshops, 2019). Consideration has been given to the cost and performance of each potential substitute in each application, relative to that of the material in question, together with the level of production, whether or not the substitute was previously considered to be 'critical' and whether the potential substitute is produced as a by-, co- or main product.

Specific data relating to all of these criteria are often difficult to find and a number of assumptions have had to be made to complete the calculations. Consequently, a significant degree of uncertainty is associated with the results. The level of precision shown for the Substitution Indices does not fully reflect this uncertainty.

Magnesium in casting alloys as well as in aluminium alloys may be partially substituted, e.g. to lower the need for magnesium. Possible substitutes are composites such as carbon-fibre reinforced plastic with recycling issues, as well as steel and titanium alloys. The information provided below for transportation, construction and packaging applications may also be found in the factsheet on aluminium substitution.

In transportation applications, reinforced plastics provide similar performance in vehicles and the latest aircraft but at much higher cost than aluminium alloys containing magnesium. Steel and titanium are possible substitutes in this sector; with steel being the only one of these where costs are similar to aluminium alloys. However, steel is heavier than aluminium and consequently lesser performing for certain applications.

In the construction sector, steel, plastics (such as PVC or vinyl) and wood were considered as possible substitutes. In all cases the cost and performance were considered to be similar to aluminium alloys containing magnesium. For packaging, steel, glass and plastics were identified as potential substitutes for aluminium alloys and again for all of these the costs and performance were considered to be similar.

The steel desulfurization process allows the use of several reagents such as lime (carbon oxide, CaO), calcium carbide (CaC<sub>2</sub>) and magnesium (Mg), which remove the sulphur in the hot metal by chemical reaction and convert it to the slag. The performance of lime and calcium carbide is lower than with magnesium: the latter is soluble in hot metal and reacts with sulphur in solution; unlike the former, magnesium is not subject to layer formation on steel, which would impede the desulfurizing reaction. Although more expensive, magnesium has approximately 20 times the capacity of removing sulphur as lime; calcium carbide, 8 times the capacity as lime (IspatGuru, 2013). Other substitutes such as zinc oxide (ZnO) are experimented but are not commercialized.

## **15.4 Supply**

---

### **15.4.1 EU supply chain**

The EU supply chain of magnesium can be described by the following key points:

- First stages of the value chain of magnesium (extraction, processing) take place outside of the EU, although there are reserves of magnesium in the EU. There are no imports of magnesium ores in Europe and all primary magnesium is processed outside the EU (except from very small volumes of magnesium alloys).
- The EU supply of magnesium entirely relies on imports of primary magnesium, as well on processing new scrap as on production of secondary magnesium (from post-consumer recycling) although less significantly. Averaged over 2012 to 2016 the EU net imports of magnesium was 112.7 kt per year (Eurostat, 2019b). The EU import reliance for magnesium is therefore 100%. Magnesium can be cast, rolled,

extruded, machined, and forged similar to any other metal. Magnesium is the lightest structural metal: one quarter the weight of steel, two thirds the weight of aluminium, and has same light weighting potential as carbon fibre. Europe imports primary magnesium in the forms of pure metal or alloys. In addition, the EU relies on imports of intermediate and final products, in particular in the electronics sector.

- At the EU level, the magnesium recycling capacity is about 75 kt/y (mostly for new scrap).
- The European Union is a net exporter of magnesium scrap, with net gross volumes of 10,370 tonnes in 2018. In 2018 40% of scrap exports are now directed to the US and 21% to Brazil, mainly due to price difference with primary magnesium (increased prices from anti-dumping measures, which were implemented in 2001). For comparison, 76% of scrap was exported to Norway in 2000 (Eurostat, 2019a)

## 15.4.2 Supply from primary materials

### 15.4.2.1 Geology, resources and reserves of magnesium

**Geological occurrence:** Magnesium is a relatively common element with a concentration of about 2.1% (21,000 ppm) in the Earth's crust, and of about 46.7 ppm in the uppercrust (Rudnick, 2003). It is found in more than 60 distinct minerals. The most important minerals containing magnesium are rock-forming minerals: the chlorites, the pyroxene and amphibole group minerals, dolomite and magnesium calcite. Magnesium is also present in magnesite and hydrated carbonates (e.g. nesquehonite, lansfordite) as well as in brucite. In addition, a series of basic magnesium carbonates exist (e.g. hydromagnesite, artinite) (Shand, 2006).

Natural minerals supply the majority of commercialised magnesium (i.e. magnesium oxide): dolomite (85%), MG-brines (15% of commercialised output) (BGR 2019). Brucite is no longer used as a raw material for primary magnesium production (IMA, 2017).

**Dolomite mineral** ( $\text{CaMg}(\text{CO}_3)_2$ ) is found in sedimentary rocks such as dolomite rock and limestones. It can occasionally be found in high-temperature metamorphic rocks and low-temperature hydrothermal veins. Dolomite is the raw material for the majority of the magnesium plants in China; it is also used in Turkey and Brazil (BGS, 2004).

**Magnesite mineral** ( $\text{MgCO}_3$ ) exist as cryptocrystalline (amorphous) magnesite or macrocrystalline (bone) magnesite. Four types of magnesite deposits exist: as a sedimentary rock, an alteration of serpentine, as a vein filling or in replacement of limestone and dolomite (Shand, 2006). Magnesite deposits are fairly widespread but high-purity deposits of adequate size are uncommon (BGS, 2004). There are EU efforts to develop new opportunities to get magnesium from low grade sources of magnesite and dolomite based on biotechnology. An example, it is the project Biorecover<sup>157</sup>.

**Carnallite** ( $\text{KCl}\cdot\text{MgCl}_2\cdot 6\text{H}_2\text{O}$ ) is the main source of magnesium in Russia and used to be significant in Chinese production, though not any longer. It is normally delivered as brine produced by the solution-mining of the solid carnallite deposits.

**Global resources and reserves**<sup>158</sup>: no information, but certainly large (USGS, 2019).

---

<sup>157</sup> <https://cordis.europa.eu/project/rcn/223260/factsheet/en>

<sup>158</sup> There is no single source of comprehensive evaluations for resources and reserves that apply the same criteria to deposits of magnesium in different geographic areas of the EU or globally. The USGS collects information about the quantity and quality of mineral resources but does not directly measure reserves, and companies or governments do not directly report reserves to the USGS. Individual companies may publish regular mineral resource and reserve reports, but reporting is done using a variety of systems of reporting

**EU resources and reserves<sup>159</sup>:** It is acknowledged that reserves of magnesium are large enough to meet the worldwide consumption needs for the next decades – either from dolomite and other magnesium-bearing evaporate minerals, or from magnesium-bearing brines.

#### **15.4.2.2 Mining of magnesium ores and refining of magnesium**

Magnesium-bearing ores are worked by open pit methods, although narrow and deep deposits may be worked by underground drifts and stopes. (United States International Trade Commission, 2012).

Magnesium can be produced through electrolytic methods or thermal-reduction methods such as the Pidgeon process.

The electrolytic method has dominated magnesium production from the 1970s to 1990s – the various processes consist of electrolysis of molten magnesium chloride (produced with different methods), the magnesium produced is liquid (molten). The source of magnesium can be seawater, brine or carnallite, among others (Wulandari et al., 2010). For instance, carnallite is used as raw material for the electrolysis process in Russia (BGR, 2017).

In the thermal-reduction method, calcined dolomite and calcined magnesite are broken down through the use of reducing agents. The mixture is heated in a vacuum chamber forming magnesium vapours which later condense into crystals. The crystals are melted, refined and poured into ingots for further processing (IMA, 2016).

The Pidgeon process is the most commonly used thermal-reduction method for production of magnesium due to the fact that its operation is relatively easy, versatile and has low capital cost; however, it is energy intensive and has low productivity. The largest producers of magnesium through the Pidgeon process are China, Brazil and Turkey (IMA, 2016). The process is based on silicothermic reduction of magnesium oxide from calcined dolomite. Dolomite calcination takes place at temperature ranges of 1,000 to 1,300°C. Calcined dolomite and ferrosilicon are mixed; at specific temperatures and pressure, the reduction of calcined dolomite by ferrosilicon produces magnesium vapor. High purity magnesium is obtained from condensation of the vapor; the potential impurities (Ca, Fe and Si) are low at these conditions (Wulandari et al., 2010).

New processes such as Carbothermic and the Mintek process are high productivity alternatives to the existing technologies that still require further development; they could achieve lower energy usage. There are EU efforts to develop new opportunities to get

---

depending on the location of their operation, their corporate identity and stock market requirements. Translations between national reporting codes are possible by application of the CRIRSCO template ([www.crirSCO.com](http://www.crirSCO.com)), which is also consistent with the United Nations Framework Classification (UNFC) system. However, reserve and resource data are changing continuously as exploration and mining proceed and are thus influenced by market conditions and should be followed continuously.

<sup>159</sup> There is no complete and harmonised dataset that presents total EU resource and reserve estimates for magnesium. The Minerals4EU project is the only EU-level repository of some mineral resource and reserve data for magnesium, but this information does not provide a complete picture for Europe. It includes estimates based on a variety of reporting codes used by different countries, and different types of non-comparable datasets (e.g. historic estimates, inferred reserves figures only, etc.). In addition, translations of Minerals4EU data by application of the CRIRSCO template is not always possible, meaning that not all resource and reserve data for magnesium at the national/regional level is consistent with the United Nations Framework Classification (UNFC) system (Minerals4EU 2019). Many documented resources in Europe are based on historic estimates and are of little current economic interest. Data for these may not always be presentable in accordance with the UNFC system. However, a very solid estimation can be done by experts.

magnesium from low grade sources of magnesite and dolomite based on biotechnology. An example, it is the project Biorecover, that it has started few month ago<sup>160</sup>.

### **15.4.2.3 World production of processed magnesium metals and alloys**

World refined production of magnesium is summarised in Figure 192 and totals 927 kt/y (average 2012-2016). Primary magnesium is commercialised as pure magnesium (99.8% purity - which may later be used in aluminium alloys) and magnesium alloys (estimated 90% magnesium content in average). Global supply of magnesium is dominated by China with about 89%<sup>161</sup> of the total refined production, equivalent to 822 kt/y (average 2012-2016, BGS data). The United States and Israel are the second and third largest producing countries respectively accounting for 4% (40 kt/y; average over 2012-2016) and 3% (27 kt/y; average over 2012-2016) respectively of worldwide primary magnesium production. It is thought that production statistics for China may include production figures based on capacity rather than actual production and that some primary magnesium may be double counted when it is sold to local magnesium alloy producers (Roskill, 2013; IMA, 2019).

Production of primary magnesium jumped from 443 kt/y in 2000 to 957 kt/y in 2015, the first year with a slight decline (983 kt/y in 2014). The worldwide sourcing of primary magnesium significantly evolved since 2000: at that time, China represented 32% of worldwide refined production, whereas the US produced up to 21% of primary magnesium (Data from BGS World Mineral Statistics).

China's dominance of global magnesium production increased in the reported period, whereas there was little or no growth in other producing countries, despite some capacity expansion (e.g. Brazil) and new primary production units (e.g. in Malaysia, South Korea and Turkey). These capacity increases remained small compared to total global production (Roskill, 2013). According to IMA, Turkey plant produces 8 kt/y, with an installed capacity of 15 kt/y<sup>162</sup>.

In 2015, there were about 50-80 magnesium smelting operations in China, most of them in the provinces of Shaanxi and Shanxi, which accounted for 61% and 28% of production. On a company basis, the largest productive capacity is held by Shanxi Yinguang Huasheng with 80 kt/y, averaged over 2012-2016, followed by Ningxia Hui-Ye Magnesium with 60 kt/y (International Mining, 2016).

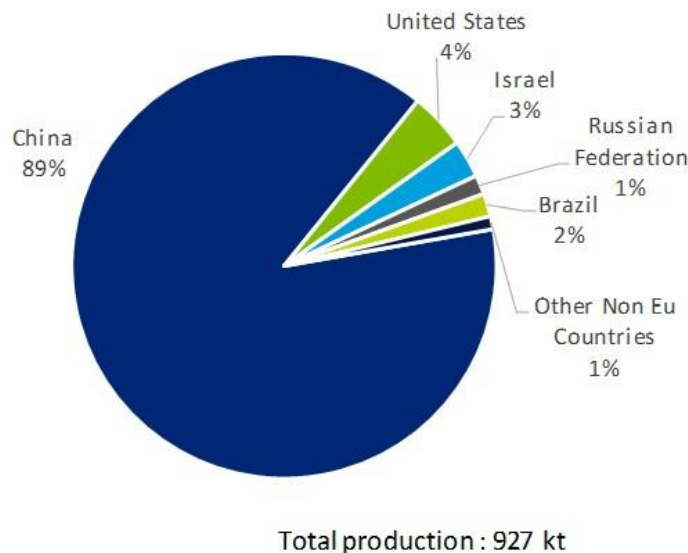
There is no production of pure magnesium metal in the EU since 2001. However, magnesium alloys are processed in the EU based on primary magnesium (e.g. magnesium alloys) imported from extra-EU countries or from secondary magnesium production (IMA, 2017).

---

<sup>160</sup> <https://cordis.europa.eu/project/rcn/223260/factsheet/en>

<sup>161</sup> 85% according to IMA

<sup>162</sup> Closed in 2018 and reopened by KAR Mineral Madencilik in 2019 (BGR, 2019)



**Figure 192: Global production of magnesium. Average 2012-2016. (BGS, 2017)**

### 15.4.3 Supply from secondary materials/recycling

#### 15.4.3.1 Post-consumer recycling (old scrap)

Secondary magnesium is an important component in global magnesium supply, with production estimated to be in the range of 200-250 kt/y, 125 t/y of which is in the USA (International Mining, 2016). The amount of secondary material used in the magnesium industry depends on various factors, among others: amount of material lost in the melting cycle, quantity of different cast components, quality of process scrap, or recycling operation efficiency (IMA, 2016). At the EU level, the magnesium recycling capacity is about 75,000 t/y (mostly for new scrap). The main European players are in Austria (Non ferrum), Czech Republic (Magnesium Elektron<sup>163</sup>), Germany (Magontec, Real Alloy Germany GmbH), Hungary (Salgo-Metal), Serbia (Mg Serbien), Romania (Magontec), and in the UK (Magnesium Elektron) (Roskill, 2013, IMA 2019). In the EU, the EoL-RIR for magnesium is estimated at 12-13%, according to three sources: 13% in the MSA study (Bio Intelligence Service 2015), 12.4 % in the Oakdene Hollins report (Bell et al. 2017) and 13.4% in the current criticality assessment, which is in turn based on the MSA of aluminium (Passarini et al. 2018).

Various recycling methods exist and are currently used to re-melt magnesium scrap: a common process is the remelting and refining of heavy scrap. In order to ensure the same quality criteria (in terms of chemical composition, oxide content) for secondary and primary materials, other recycling methods may be required, in particular for old scrap. For instance, the addition of manganese reduces the levels of iron; distillation or dilution allow for nickel and copper control (IMA, 2016).

In the EU, a large share of magnesium is used as an alloying element in the production of aluminium alloys and derived applications. Therefore, most of end-of-life magnesium scrap is recycled as part of the aluminium value stream. In addition, magnesium alloys are entirely recyclable once they are collected from end-of-life products.

<sup>163</sup> Plant sold to: Crown Metals CZ s.r.o.

### 15.4.3.2 Industrial recycling (new scrap)

Recycling or reuse of new scrap is common in the magnesium industry; the scrap kept within a close loop system reduces the demand of primary magnesium by up to 50%. Die casting foundries recycle scrap internally or externally. Lower grade arising is used as reagents in steel desulfurization or other markets, as replacement to primary magnesium (IMA, 2016). There is no recycling of magnesium from steel desulfurization applications.

## 15.5 Other considerations

---

### 15.5.1 Environmental issues

Magnesium alloys have a great potential to reduce vehicle weight, fuel consumption, and greenhouse gas emissions in vehicles use life (Du et al., 2010). However, most magnesium is produced in China through the Pidgeon process that has an intensive energy usage and generates a large amount of greenhouse gas emissions, which may offset the potential advantage of using magnesium parts in automobiles (Cherubini et al., 2008).

New Mg primary projects are indicating a much more reduced Global Warming Potential (GWP) compared to China Pidgeon process. Magnesium out of the Qinghai Magnesium complex claims a GWP of 7.1 kg of CO<sub>2</sub> per kg of magnesium and also Latrobe Magnesium and Alliance Magnesium indicate much lower GWP (IMA 2019).

### 15.5.2 Socio-economic issues

No specific issues were identified during data collection and stakeholders consultation.

## 15.6 Comparison with previous EU assessments

---

The assessment has been conducted using the revised methodology introduced in the 2017 assessment. Therefore, the calculations of economic importance and supply risk are not directly comparable with results of the 2011 and 2014 assessments. Supply risk has been analysed at processing stage only. The results of this and earlier assessments are presented in Table 84.

**Table 84: Economic importance and supply risk results for magnesium in the assessments of 2011, 2014, 2017, 2020 (European Commission, 2011a-2014b-2017c)**

Assessment	2011		2014		2017		2020	
	EI	SR	EI	SR	EI	SR	EI	SR
Magnesium	6.45	2.62	5.48	2.53	7.14	3.98	6.63	3.91

Both the economic importance and supply risk of magnesium have increased since 2011 till 2017, and decreased in 2020.



## 15.7 Data sources

---

Market shares are based on existing studies (Bio Intelligence Service, 2015) and stakeholders' feedback (IMA, 2019; SCRREEN workshops, 2019). Production data for magnesium metal and alloys are from BGS World Mineral Statistics dataset. Additional feedback was received from stakeholders and included in the assessment to obtain data best representative of the global supply. Trade data were extracted from the Eurostat Easy Comext database (Eurostat, 2019a). Data on trade agreements are taken from the DG Trade webpages, which include information on trade agreements between the EU and other countries (European Commission, 2019). Information on export restrictions are derived from the OECD Export restrictions on the Industrial Raw Materials database (OECD, 2019).

For trade data the Combined Nomenclature (CN) codes 81041100 'Unwrought magnesium, containing  $\geq 99.8\%$  by weight of magnesium' and 81041900 'Unwrought magnesium, containing  $< 99.8\%$  by weight of magnesium' have been used.

The EoL-RIR for magnesium was estimated considering that recycling of magnesium metal and alloys are similar to recycling of aluminium alloys.

### 15.7.1 Data sources used in the factsheet

antidumpingpublishing.com (2017). US – expedite sunset reviews on magnesium and artists' canvas. [online] Available at: <http://www.antidumpingpublishing.com/us-expedite-sunset-reviews-on-magnesium-and-artists-canvas/>

Bell N., Waugh R. and Parker D. (2017) Magnesium Recycling in the EU. Material flow analysis of magnesium (metal) in the EU and a derivation of the recycling rate. A report by Oakdene Hollins for IMA (International Magnesium Association)

Bio Intelligence Service (2015). Study on Data for a Raw Material System Analysis: Roadmap and Test of the Fully Operational MSA for Raw Materials – Final Report. Prepared for the European Commission, DG GROW. p 41-43

BGR (2017). Communication during the review

BGR (2019). Communication during the review

BGS (2004). Commodity profile – Magnesium.

BGS (2016). World Mineral Statistics. [online] Available at: <https://www.bgs.ac.uk/mineralsuk/statistics/worldStatistics.html>

Cherubini, F., Raugei, M. and Ulgiati, S. (2008). LCA of magnesium production: Technological overview and worldwide estimation of environmental burdens. *Resources, Conservation and Recycling*, 52(8-9), pp.1093-1100.

Du, J., Han, W. and Peng, Y. (2010). Life cycle greenhouse gases, energy and cost assessment of automobiles using magnesium from Chinese Pidgeon process. *Journal of Cleaner Production*, 18(2), pp.112-119.

European Commission (2010). Critical raw materials for the EU. [online] Available at: [https://ec.europa.eu/growth/sectors/raw-materials/specific-interest/critical\\_en](https://ec.europa.eu/growth/sectors/raw-materials/specific-interest/critical_en)

European Commission (2014)a. Report on Critical Raw Materials for the EU. [online] Available at: [https://ec.europa.eu/growth/sectors/raw-materials/specific-interest/critical\\_en](https://ec.europa.eu/growth/sectors/raw-materials/specific-interest/critical_en)

European Commission (2014)b. Report on Critical Raw Materials for the EU. Non-Critical Raw Materials Profiles [online] Brussels European Commission, Available at: <http://ec.europa.eu/growth/sectors/raw-materials/specific-interest/critical/>

European Commission (2016). DG Trade. Agreements [online] Available at: <http://ec.europa.eu/trade/policy/countries-and-regions/agreements/>

Eurostat (2019)a. International Trade Easy Comext Database [online] Available at: <http://epp.eurostat.ec.europa.eu/newxtweb/>

Eurostat (2019)b. Statistics on the production of manufactured goods (PRODCOM NACE Rev.2). [online] Available at: <http://ec.europa.eu/eurostat/data/database>

Eurostat (2019)c. Annual detailed enterprise statistics for industry (NACE Rev. 2, B-E). [online] Available at: [http://ec.europa.eu/eurostat/en/web/products-datasets/-/SBS\\_NA\\_IND\\_R2](http://ec.europa.eu/eurostat/en/web/products-datasets/-/SBS_NA_IND_R2)

Future Market Insights (2016). Magnesium Metal will Witness Steady Demand in 2016, Global Consumption to Reach 1,085 KT. [online] Available at: <http://www.futuremarketinsights.com/press-release/magnesium-metal-market>

IMA (2016). [online] Available at: <http://www.intlmag.org/>

IMA (2019). Communication during the review

IMA (2019). Communication during the review

InfoMine (2017). Charts & Data. [online] Available at: <http://www.infomine.com/ChartsAndData/ChartBuilder.aspx?z=f&gf=110543.USD.kg&dr=max&cd=1>

International Mining (2016). Magnesium: great future potential. [online] Available at: <http://im-mining.com/2016/06/28/magnesium-great-future-potential/>

IspatGuru (2013). Desulphurization of hot metal. [online] Available at: <http://ispatguru.com/desulphurization-of-hot-metal/>

Kramer (2006). Magnesium Minerals and Compounds.

Minerals4EU (2019). European Minerals Yearbook. [online] Available at: [http://minerals4eu.brgm-rec.fr/m4eu-yearbook/theme\\_selection.html](http://minerals4eu.brgm-rec.fr/m4eu-yearbook/theme_selection.html)

OECD (2019). OECD Export restrictions on Industrial Raw Materials database. [online] Available at: [http://qdd.oecd.org/subject.aspx?Subject=ExportRestrictions\\_IndustrialRawMaterials](http://qdd.oecd.org/subject.aspx?Subject=ExportRestrictions_IndustrialRawMaterials)

Passarini, F., Ciacci L., Nuss P. and Manfredi S., Material Flow Analysis of Aluminium, Copper, and Iron in the EU-28, EUR 29220 EN, Publications Office of the European Union, Luxembourg, 2018, ISBN 978-92-79-85744-7, doi:10.2760/1079, JRC111643

Roskill (2013). Magnesium Metal: Global Industry Markets and Outlook

Rudnick, R.L. and Gao. S. (2003). Composition of the Continental Crust. In: Treatise on Geochemistry, Volume 3. Editor: Roberta L. Rudnick. Executive Editors: Heinrich D. Holland and Karl K. Turekian. pp. 659. ISBN 0-08-043751-6. Elsevier, p.1-64

SCREEN workshop. (2019). "Validation Workshop on Critical Raw Materials, 10-12 September 2019, Thon Hotel Brussels City Centre."

Shand (2006). The Chemistry and Technology of Magnesia – Chapter 2: Formation and occurrence of magnesite and brucite.

United States International Trade Commission (2012). Pure Magnesium (Granular) from China investigation no. 731-TA-895 (second review). [online] Available at: [https://www.usitc.gov/publications/701\\_731/pub4350.pdf](https://www.usitc.gov/publications/701_731/pub4350.pdf)

USGS (2016). Historical Statistics for Mineral and Material Commodities in the United States. [online] Available at: <https://minerals.usgs.gov/minerals/pubs/historical-statistics/> [accessed December 2016].

Wulandari et al. (2010). Magnesium: current and alternative production routes. [online] Available at: <http://ro.uow.edu.au/cgi/viewcontent.cgi?article=2295&context=engpapers>

### **15.7.2 Data sources used in the criticality assessment**

BGS (2016). European Mineral Statistics. [online] Available at: <https://www.bgs.ac.uk/mineralsuk/statistics/europeanStatistics.html>

Bio Intelligence Service (2015). Study on Data for a Raw Material System Analysis: Roadmap and Test of the Fully Operational MSA for Raw Materials – Final Report. Prepared for the European Commission, DG GROW. p 41-43

BRGM (2016). Communication during the review, confirmed by the ICG non-ferrous metals

CRM InnoNet (2015) Substitution of Critical Raw Materials – Deliverable report – D5.3 Final Roadmap Report. [online] Available at: [http://www.criticalrawmaterials.eu/wp-content/uploads/D5.3-Final-Roadmap-report\\_rev-Oct15.pdf](http://www.criticalrawmaterials.eu/wp-content/uploads/D5.3-Final-Roadmap-report_rev-Oct15.pdf)

Eurostat (2019)a. International Trade Easy Comext Database. [online] Available at: <http://epp.eurostat.ec.europa.eu/newxtweb/>

Eurostat (2019)b. Statistics on the production of manufactured goods (PRODCOM NACE Rev.2). [online] Available at: <http://ec.europa.eu/eurostat/data/database>

European Commission (2014). Report on Critical Raw Materials for the EU. [online] Available at: [https://ec.europa.eu/growth/sectors/raw-materials/specific-interest/critical\\_en](https://ec.europa.eu/growth/sectors/raw-materials/specific-interest/critical_en)

European Commission (2016). DG Trade. Agreements [online] Available at: <http://ec.europa.eu/trade/policy/countries-and-regions/agreements/>

Glass Alliance Europe (2015). Industries. [online] Available at: <http://www.glassallianceeurope.eu/en/industries>

IMA (2016). Communication during the review

Institute of Food Technologists (2007). Food Packaging – Roles, Materials, and Environmental Issues. [online] Available at: <http://www.ift.org/knowledge-center/read-ift-publications/science-reports/scientific-status-summaries/food-packaging.aspx>

IspatGuru (2013). Desulphurization of hot metal. [online] Available at: <http://ispatguru.com/desulphurization-of-hot-metal/>

Lindström (2014). A Study on Desulfurization of Hot Metal Using Different Agents. [online] Available at: <http://www.diva-portal.org/smash/get/diva2:710128/FULLTEXT02>

Monteiro et al. (2012). Application of Magnesium Alloys in Transport. [online] Available at: <http://cdn.intechopen.com/pdfs-wm/37745.pdf>

OECD (2016). Export restrictions on Industrial Raw Materials database. [online] Available at: [http://qdd.oecd.org/subject.aspx?Subject=ExportRestrictions\\_IndustrialRawMaterials](http://qdd.oecd.org/subject.aspx?Subject=ExportRestrictions_IndustrialRawMaterials)

Plastics Europe (2016). An analysis of European plastics production, demand and waste data. [online] Available at: [http://www.plasticseurope.org/documents/document/20151216062602-plastics\\_the\\_facts\\_2015\\_final\\_30pages\\_14122015.pdf](http://www.plasticseurope.org/documents/document/20151216062602-plastics_the_facts_2015_final_30pages_14122015.pdf)

Plastics Europe (2015). Building and Construction. [online] Available at: <http://www.plasticseurope.org/use-of-plastics/building-construction.aspx>

UNECE Forests, Land and Housing Division (2016). Forest Products Statistics 2010-2014. [online] Available at: <http://www.unece.org/fileadmin/DAM/timber/statsdata/fps10-14.pdf>

UNEP (2011). Recycling Rates of Metals – A Status Report.

US Department of Energy (2015). Advanced Composites Materials and their Manufacture Technology Assessment. [online] Available at: <http://energy.gov/sites/prod/files/2015/02/f19/QTR%20Ch8%20-%20Composite%20Materials%20and%20Manufacture%20Feb-13-2015.pdf>

USGS. (2019). Mineral Commodity Summaries 2019. U.S Geological Survey.

Infosys (2015). Whitepaper – Carbon composites are becoming competitive and cost effective. [online] Available at: <https://www.infosys.com/engineering-services/white-papers/Documents/carbon-composites-cost-effective.pdf>

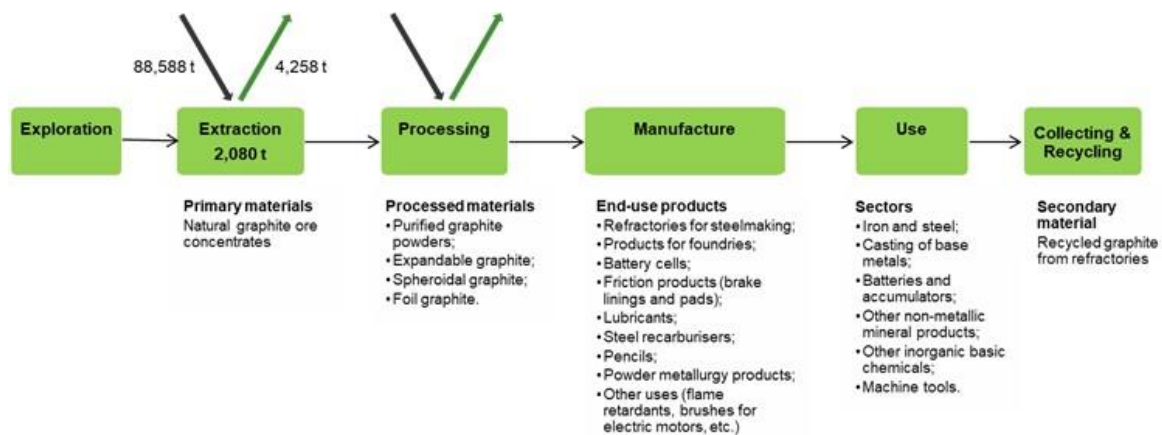
## **15.8 Acknowledgments**

---

This factsheet was prepared by the JRC. The authors would like to thank the Federal Institute for Geosciences and Natural Resources, BGR (Martin Schmitz and Antje Wittemberg), the International Magnesium Association IMA (Martin Tauber), as well as the EC Ad Hoc Working Group on Critical Raw Materials and all other relevant stakeholders for their contributions to the preparation of this Factsheet.

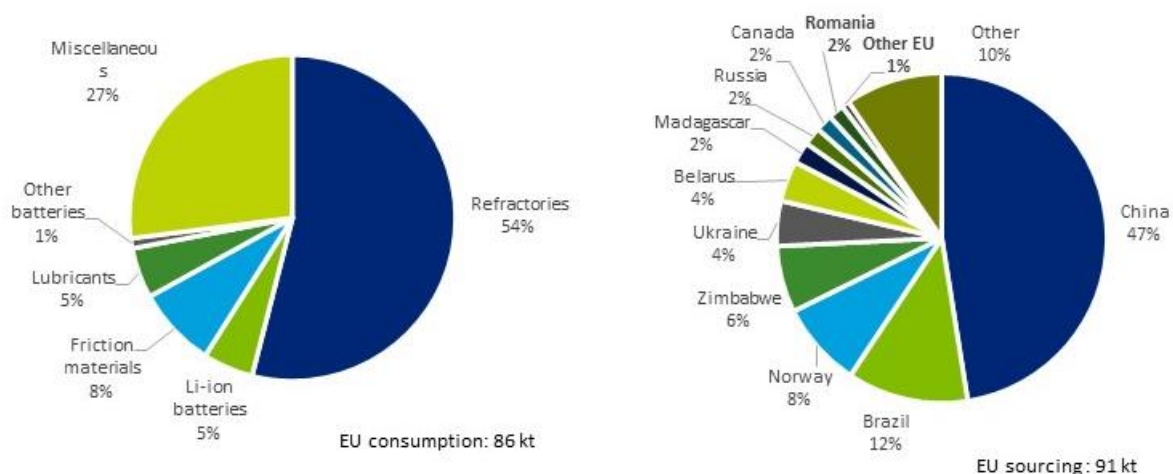
# 16 NATURAL GRAPHITE

## 16.1 Overview



**Figure 193: Simplified value chain for natural graphite<sup>164</sup> (average 2012-2016)**

Natural graphite (C, atomic number 6) is a carbon allotrope which exhibits both metallic and non-metallic properties. It is a soft (hardness 1-2 on Mohs scale), grey-black mineral with perfect basal cleavage. It consists of planar sheets formed from three-coordinated carbon atoms. Intra-planar bonding is powerful, but forces holding these sheets together are weak, so the layers can easily slide over each other. Free electrons between the layers allow graphite to conduct electricity and heat. It is a good thermal and electrical conductor and has a high melting point (3,650 °C). Graphite has a high thermal resistance and lubricity, is resistant to corrosion, chemically inert and non-toxic. These properties make it a raw material with a wide range of uses. There are three types of natural graphite for commercial use, classified by purity and particle size: flake graphite (with a distinct flake structure that is categorised by the industry in terms of size as fine, medium or large), amorphous graphite (with no flake structure and typically lower carbon grade) and vein graphite (a speciality product only produced in Sri Lanka).



**Figure 194: End uses of natural graphite in the EU, and EU sourcing of natural graphite (average 2012-2016)**

<sup>164</sup> JRC elaboration on multiple sources (see next sections)

In the criticality assessment natural graphite is analysed at the extraction stage. The trade codes used in this assessment are: CN 25041000 "Natural graphite in powder or in flakes"; CN 25049000 "Natural graphite (excl. in powder or in flakes)". A carbon content of 95% is assumed for trade flows. Quantities are expressed in C content, and all figures are averaged over the five years 2012–2016 unless otherwise mentioned.

China is the largest world producer and exporter of natural graphite with 71% and 59% market shares, respectively, in 2017. China is the dominant consumer of natural graphite used in batteries, and the only commercial-scale producer for battery-grade spherical graphite. Natural graphite's consumption is directly related to the production of steel, due to its widespread use in refractories. The deployment of electric vehicles and the development of energy storage systems is projected to drive most of the growth of future natural graphite demand. The outlook for future supply is positive as supply is increasing from Africa led by the ramp up of production in Mozambique, and as a number of large-scale natural flake graphite projects are anticipated to reach production by 2025.

Following the 2011 market boom when flake graphite prices soared due to China's huge steel needs, prices returned to low levels due to excess production and weak demand from the steel industry. A short-term recovery occurred in 2018 driven by reduced supply and strong demand for Li-ion batteries, but prices have been suppressed again as supply from new projects in Africa began to ramp up. Flake graphite of higher purity and size attracts premium prices, whereas amorphous prices are much lower. Heavily processed graphite products such as spherical graphite command significantly higher prices.

The EU consumption of natural graphite is about 86 kt, of which only 2% is sourced through domestic production. China is the principal supplier of natural graphite, providing almost half of the EU demand (47%). Other important suppliers are Brazil (12%), Norway (8%) and Zimbabwe (7%). The EU import reliance for natural graphite is 98%.

Due to its diverse properties, natural graphite is a material applied in a broad spectrum of industrial sectors. Although only a small proportion of refractories contain graphite, refractories for steelmaking are the leading consumer of natural graphite. Other uses include foundry applications, lubricants, friction materials, batteries, brushes for electrical motors, sealing applications, fire retardants, and pencils. Synthetic graphite can be used instead of natural graphite in several applications such as batteries, brake linings, lubricants and carbon brushes. Synthetic graphite cannot substitute natural graphite in refractory applications.

Natural graphite is used to manufacture the anode in batteries and fuel cells for electric vehicles and energy storage systems. The uptake of electromobility is expected to decarbonise the transport sector, especially in combination with the decarbonisation of power generation. Energy storage systems are essential for development of renewable, intermittent energy sources in order to decarbonise the power production sector.

China hosts half of the world's graphite reserves, estimated at 110,000 kt. Significant reserves are also located in Mozambique and Tanzania, each with a 15% share of world's total. Concerning the EU, the largest natural graphite deposits are situated in Sweden, Czech Republic and Finland.

China is the largest global supplier of natural graphite with 69% of production, followed by India (12%) and Brazil (8%). Small quantities of natural graphite are currently produced in Germany and Austria. The EOL-RIR of natural graphite in the EU is only 3%.

## 16.2 Market analysis, trade and prices

---

### 16.2.1 Global market

The graphite market is complex and fragmented because natural graphite is not a homogeneous commodity. Both natural and synthetic graphite can be used in several applications. A large portion of the total the demand for graphite is met by synthetic graphite, which are estimated at 1,500-1,600kt., whereas the current size of the natural graphite market is estimated for around 1 million tonnes (Leguérinel and Le Gleuher 2017).

The end uses, and the associated commercial value of natural graphite is determined by the characteristics of the mined natural graphite and the subsequent processing of natural graphite concentrates. In many cases, specific applications require one type of processed graphite in particular. Three types of natural graphite are mined for commercial use, classified by purity and particle size: flake graphite, amorphous or microcrystalline graphite, and vein or lump graphite. The production of flake graphite accounts for 50% to 60% of the total production of natural graphite, the production of amorphous graphite for 40% to 50%, and vein graphite for less than 1% (Roskill 2015) (Leguérinel and Le Gleuher 2017). The market value of the world mine production of natural graphite is estimated at EUR 0.75 billion<sup>165</sup> in 2017.

Natural graphite is mined in several countries, but production is concentrated in China, which dominates the world natural graphite production with a share of 71% in 2017 (WMD 2019). According to USGS (USGS 2018b) approximately 70% of China's output is amorphous graphite, and 30% is flake graphite with a low proportion of large flakes in size distribution. According to Roskill (Roskill 2015), in 2014 the shares of amorphous and flake graphite production in China were almost 50%, and since 2010 the production of amorphous graphite has undergone major consolidations in the Hunan region.

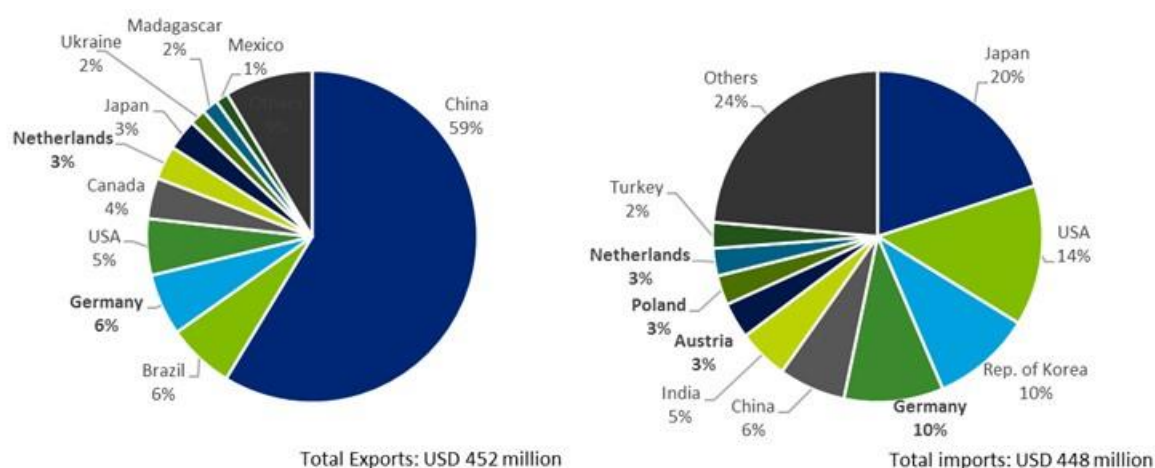
The iron and steel industry have been the largest market for natural graphite, through their use of graphite in refractories, foundries and as a recarburiser. The steady growth of the Chinese steel industry has been the driving force for natural graphite demand for the last two decades. The world production of natural graphite fell by a compound annual rate of 0.2% between 2007 and 2016. This can be attributed to a slow-down of Chinese steel production between 2011 and 2014 and a decrease in 2015, reducing China's demand for refractories (Roskill 2015), (European Commission 2014).

China is the dominant supplier of natural graphite worldwide, accounting for 59% of the value of world exports in 2017. Brazil and Germany are following the rank of top world exporters of natural graphite, accounting for 6% of the total value of exports each. Japan is the primary destination country for world exports of natural graphite with a 20% share of the value of global imports in 2017, followed by the US (14%), South Korea (10%) and Germany (10%) (see Figure 195). Despite being a major exporter, since 2018 China has begun to import large quantities of flake graphite suitable for processing in battery-grade from Mozambique and Madagascar in order to meet the surging demand in the world's largest lithium-ion battery industry. China's own graphite resources are becoming harder to reach and production costs continue to rise (Roskill 2019a) (Roskill 2019d).

---

<sup>165</sup> Estimation based on the reported production by World Mining Data of 943 kt for 2017, times the average unit value of EU imports of natural graphite (HS 2504) in 2016 (EUR 777 per tonne)

Figure 195 presents the top world importers and exporters of natural graphite based on trade data for trade code HS 250410 “Natural graphite in powder or in flakes” and HS 250490 “Natural graphite (excl. in powder or in flakes)”.



**Figure 195: Top-10 natural graphite exporting (left) and importing (right) countries in 2017 by value. Background data from (UN Comtrade 2019)**

Concerning downstream high-value products of natural graphite, China is the largest producer of natural graphite suitable for processing into spherical graphite. Furthermore, almost all of the world's output of spherical graphite for lithium-ion battery anode material is carried out in China, which is either consumed domestically or exported to Japan and South Korea for use in lithium-ion batteries (Roskill 2015). A small number of companies outside China have also developed spherical graphite, but they only account for a tiny part of global production (Roskill 2015). China dominates the anode materials market and hosts the largest overall capacity (370 kt or 78% of the worldwide capacity) for anode materials used in Li-ion batteries (Roskill 2019f). Since 2018, a number of flake graphite mining companies outside China have ongoing development projects to produce spherical graphite. Most of them operate in Africa and North America, to become the first commercial-scale producers outside of China (Roskill 2019d).

### 16.2.2 Outlook for supply and demand

The battery sector is expected to drive the growth of future graphite demand due to the transition to electric mobility and the development of the energy storage market. Steel-associated applications such as refractories, which underpin demand as the most important consumers, are projected to increase as well, but to a lesser extent; in case the steelmaking industry activity remains constant in the short-term consumption for refractories is expected to decline (Roskill 2015) (USGS 2018b). The market of expandable graphite for foil, insulation and fire retardant products is expected to grow fast. High-tech emerging applications, such as fuel cells and pebble-bed nuclear reactors, will also note a rise in demand (USGS 2018b). However, a significant impact on the market from fuel cells, which integrate large quantities (around 90 kg in a vehicle) of synthetic or natural graphite of very high purity, is not anticipated by 2030. A notable increase in future demand for new types of nuclear reactors is more uncertain in the same timeframe (Leguérinel and Le Gleuher 2017).

The prospects of the demand growth for lithium-ion batteries are discussed in many studies and the projected surge is beyond doubt. According to the forecasts made in the context of the H2020 SCRREEN project, the demand for graphite for domestic energy storage and electric vehicles is forecasted to grow exponentially in the EU. In 2035, it is



projected to reach 41 kt for energy storage and 98 kt for electric vehicles, as compared to 0,1 kt and 0,07 kt of demand respectively in 2015 (Ait Abderrahim and Monnet 2018).

The outlook for natural graphite supply is positive as several companies continue to develop new mining projects in Africa, Australia, Canada, US, Sweden etc. (S&P Global Market Intelligence 2018) (Scogings, Chesters, and Shaw 2015). In 2017, Syrah Resources began production at its large-scale Balama flake graphite project in Mozambique with a capacity of 350 kt of graphite concentrate per year. The mine's production ramped up to more than 100 kt in its first year of operation in 2018, becoming the largest producer globally. The vast majority of its shipments have been addressed to the Chinese battery industry. At the end of 2018, the Balama project hosted the world's largest reserve of graphite. It contained about 113,000 kt of reserves at an average grade of 16.4% TGC, equivalent to 18.500 kt of graphite (Syrah Resources 2019). Most large-scale projects at advanced development stage moving closer to first production are situated in Africa, i.e. Mozambique, Madagascar, and Tanzania (S&P Global Market Intelligence 2018), (Roskill 2019e).

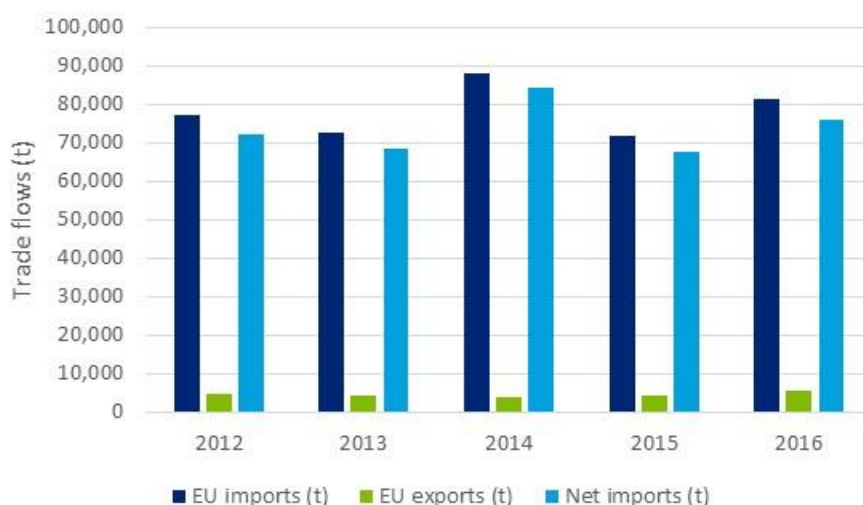
The market outlook for natural graphite global supply and demand is presented in Table 85.

**Table 85: Qualitative forecast of supply and demand of natural graphite**

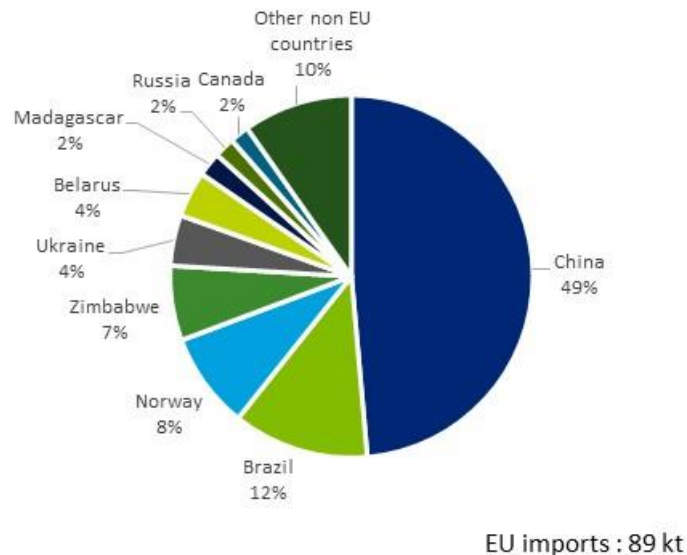
Material	Criticality of the material in 2020		Demand forecast			Supply forecast		
	Yes	No	5 years	10 years	20 years	5 years	10 years	20 years
Natural graphite	x		+	+	+	+	+	+

### 16.2.3 EU trade

The EU is greatly reliant on imports for its natural graphite supply and imports about 89 kt per year on average during the period 2012-2016 (see Figure 196). Significant intra-EU trade also takes place (ESTAT Comext 2019). Almost half of the EU imports came from China (49%), 12% from Brazil and 8% from Norway. In the same period, the EU exported small amounts of natural graphite of about 4.5 kt. Figure 196 illustrates the import and export flows of natural graphite to and from the EU. Figure 197 shows the origin countries for the EU imports of natural graphite.



**Figure 196: EU trade flows for natural graphite (ESTAT Comext 2019)**



**Figure 197: EU imports of natural graphite. Average 2012-2016<sup>166</sup> (ESTAT Comext 2019)**

China, the main EU supplier and the dominant world producer, applied a 20% tax in 2017 to exports of both HS 250410 and HS 250490 natural graphite grades (OECD 2019). However, according to BRGM, China abolished the tax on exports of natural graphite on 1/1/2017 (Leguérinel and Le Gleuher 2017). Trade relations with Norway, the third supplier of natural graphite to the EU, are governed by the agreement on the European Economic Area (EEA), which stipulates free movement of goods (European Commission 2019). Finally, the EU signed an Economic Partnership Agreement (EPA) on 10 June 2016 with the Southern African Development Community (SADC). Among other countries, the agreement comprises Mozambique, an emerging significant producer of natural graphite. Mozambique started applying the EPA in February 2018 (European Commission 2019).

### 16.2.4 Prices and price volatility

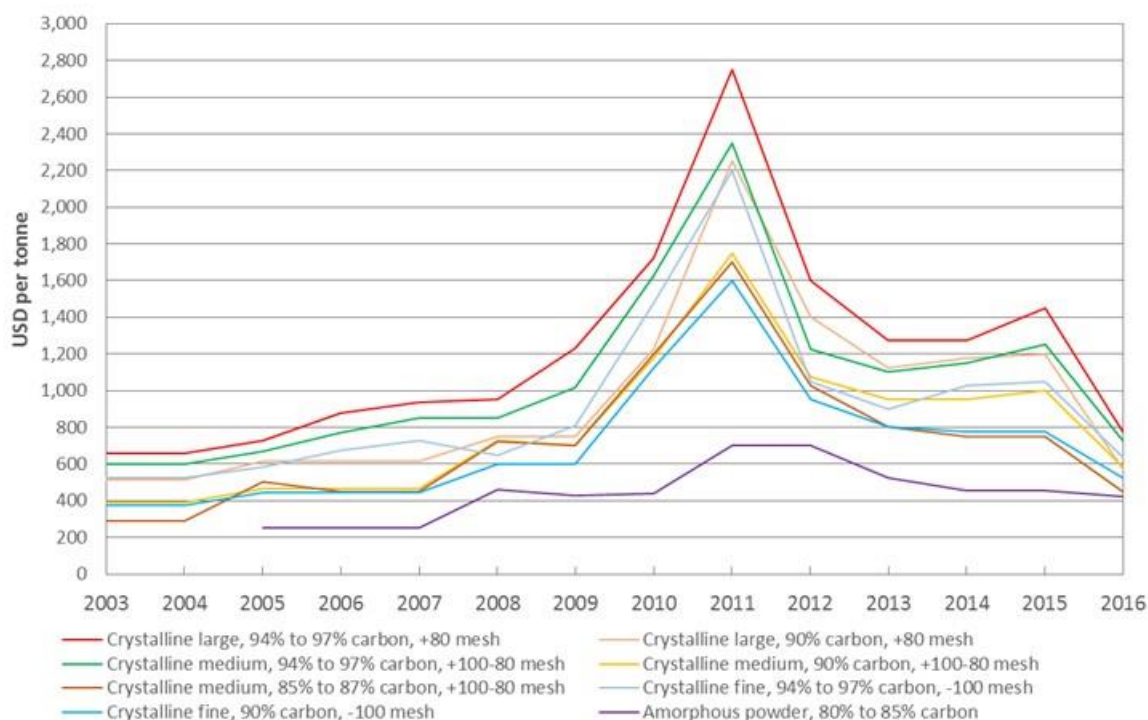
Natural graphite is not traded on commodity exchanges, and there are no spot or futures markets. Prices are established by direct negotiations between buyers and producers on the basis of quarterly or monthly contracts (Leguérinel and Le Gleuher 2017). The steel industry demand historically drives graphite price. Another key demand driver is currently the expanding Li-ion battery sector.

Natural graphite's price is a function of the type of graphite (amorphous or flake). The carbon content and particle size (mesh size) are the main parameters controlling the quality and price of each type. The nature and amount of impurities (ash) are also affecting prices. Larger (+80 mesh and above) and purer (94% plus carbon) flakes are priced at higher rates as they are desirable for a lot of end uses, whereas amorphous graphite prices are much lower.

After a long period of stable and low prices until 2005, flake graphite prices started to climb gradually. From 2009 to 2011 natural graphite prices rose sharply for flake graphite, with large flake reaching up to USD 3,000 per tonne in early 2012, on account of strong

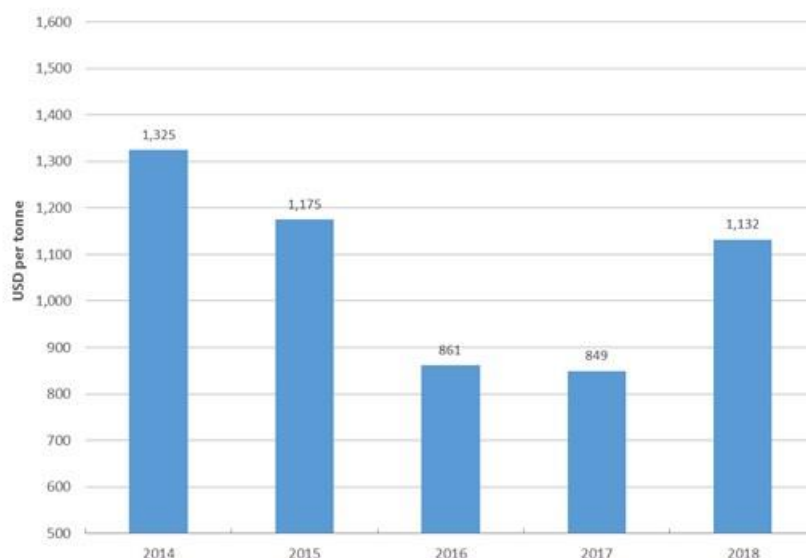
<sup>166</sup> Since there was no information in Eurostat (Comext) for the entire averaging period for some countries, only the available data were used in the average for the period 2012-2016. For example, imports from Zimbabwe are only reported for the year 2016, therefore, the average for the period 2012-2016 contains only year 2016.

demand from the steel industry in China and other applications (e.g. friction materials, lubricants, graphite foils, alkaline batteries), and fears of supply deficit due to forecasts for increased demand in emerging applications. Prices subsequently experienced a long decline again due to excess production and reduced demand from the steel industry (Leguérinel and Le Gleuher 2017), (Robinson, Hammarstrom, and Olson 2017), (Roskill 2015), (Northern Graphite 2019). The price of large, high-grade flake graphite, which attracts the highest rates in the market, fell by 70% from December 2011 to December 2016 (from USD 2500-3000 per tonne in 2011 to USD 700-750 per tonne in December 2016) on the European market (Figure 198). The fall in prices is more noticeable for flakes that are more dependent on the steel sector than amorphous graphite, the price of which has remained relatively stable since 2014 between USD 350-800 per tonne (USGS 2019a).



**Figure 198: Natural graphite median price of published weekly prices by type, at end-of-year. CIF Europe (USD/tonne). Background data from Industrial Minerals in (USGS 2019a)**

In the second half of 2017 natural graphite prices recovered. The average annual price for large, high-grade flake graphite rose by 33% in 2018 compared to 2017 (Figure 199), whereas the yearly average unit value of all EU natural graphite imports (for trade code HS 2504) has also increased by 10% in 2018 to EUR 856 per tonne (background data from (ESTAT Comext 2019)). The recovery can be attributed to improving demand from steel industry, environmental-related plant closures in China and sustained rising demand from the lithium-ion battery industry (Northern Graphite 2019). In 2019, prices have seen a downwards readjustment due to supply-side pressures as a large amount of supply is entering the market from the ramp-up of newly commissioned mines in Mozambique and Madagascar (Northern Graphite 2019) (Roskill 2019b).



**Figure 199: Price trend of large flake graphite, 94-97 % C, +80 mesh, CIF Europe, yearly average (USD/tonne). Background data from (BGR 2019)**

Heavily processed graphite products such as spherical graphite, expandable graphite and high-purity graphite attract higher prices. The price of spherical graphite depends on the price of the raw material as well as the purity, size and shape of the particles (Leguérinel and Le Gleuher 2017). In the first nine months of 2015, the average value of uncoated spherical graphite exported from China was USD 4,400 per tonne, around six times higher than the value of conventional flake exports (Roskill 2015). Prices for coated spherical graphite, the end product used in the manufacture of Li-ion battery anodes, are even higher, between USD 8,000 and 12,000 per tonne, a price comparable to synthetic graphite (Leguérinel and Le Gleuher 2017). The average value of spherical graphite imports to China, which consist mainly of coated products, was USD 9,400 per tonne in the first nine months of 2015 (Roskill 2015).

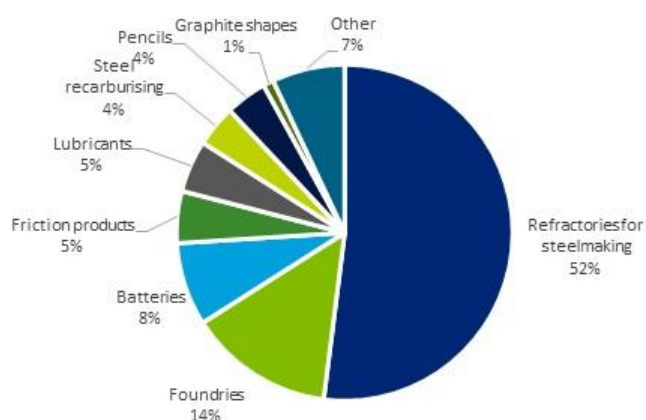
## 16.3 EU demand

### 16.3.1 EU consumption

With an apparent consumption of natural graphite of about 85,000 tonnes per year on average over the period 2012-2016 and a limited mine production, the EU is heavily dependent on external sources of supply. The EU import reliance as a percentage of apparent consumption is 98%.

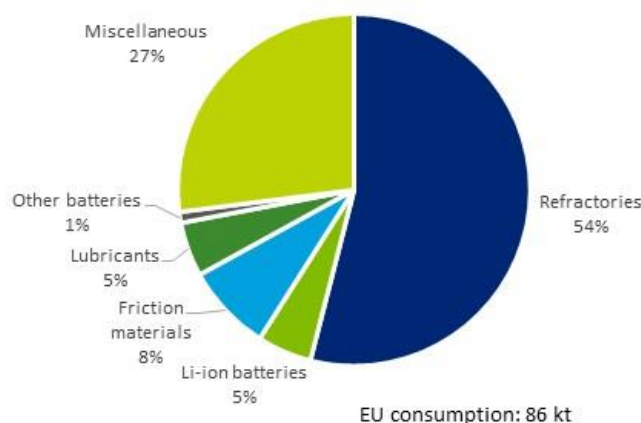
### 16.3.2 Uses and end-uses of natural graphite in the EU

Refractories for the steel industry are the largest market for natural graphite consuming about half of the world's production of natural graphite, even though that only a small proportion of refractories contain graphite. On a global scale, in 2014 about 70% of the world's natural graphite consumption was destined for metallurgical applications, in particular for the manufacture of refractories for steelmaking (54%), applications in foundries (15%), and recarburising in the steel industry (4%). The battery market accounted for 8% of global graphite consumption in 2014 (see Figure 200).



**Figure 200: Global end uses of natural graphite in 2014. (BRGM 2016)**

Figure 201 presents the breakdown of natural graphite consumption in the EU in 2016. The distribution shows that the main application is also in refractories with a similar share in the total material use (54%). Other applications include batteries (6%), friction products (8%), lubricants (5%), and other miscellaneous.



**Figure 201: EU end uses of natural graphite<sup>167</sup> in 2016. Background data from (Draft MSA 2019)**

Relevant industry sectors are described using the NACE sector codes in Table 86. Since it was not possible to assign sectors for the 27% of the EU applications (see Figure 201), the global distribution was used in the assessment as presented in Figure 200.

**Table 86: Natural graphite applications, 2-digit NACE sectors and examples of associated 4-digit NACE sector, and value-added per sector (Eurostat 2019)**

Applications	2-digit NACE sector	Value-added of sector (millions €)	Examples of 4-digit NACE sector
Refractories for steelmaking	C24 - Manufacture of basic metals	55,426	C2410 - Manufacture of basic iron and steel and of ferro-alloys
Refractories for foundries	C23 - Manufacture of other non-metallic mineral products	57,255	C2311 - Manufacture of flat glass
Batteries	C27 - Manufacture of electrical equipment	80,745	C2720 - Manufacture of batteries and accumulators

<sup>167</sup> Natural graphite demand for finished products manufactured in the EU

Applications	2-digit NACE sector	Value-added of sector (millions €)	Examples of 4-digit NACE sector
Friction products	C23 - Manufacture of other non-metallic mineral products	57,255	C2399 - Manufacture of other non-metallic mineral products n.e.c.
Lubricants	C20 - Manufacture of chemicals and chemical products	105,514	C2013 - Manufacture of other inorganic basic chemicals
Recarburising	C24 - Manufacture of basic metals	55,426	C2410 - Manufacture of basic iron and steel and of ferro-alloys
Pencils	C23 - Manufacture of other non-metallic mineral products	57,255	C23.9.9 - Manufacture of other non-metallic mineral products n.e.c.
Graphite shapes	C28 - Manufacture of machinery and equipment n.e.c.	182,589	C2849 - Manufacture of other machine tools

Due to its combination of metallic and non-metallic properties, natural graphite is used for a wide variety of applications which are described below (Yang, Hu, Sundqvist, Eriksson, Bacher, John, et al. 2018), (BRGM 2012),(Roskill 2015)(European Commission 2017),(Robinson, Hammarstrom, and Olson 2017):

- Refractories for steelmaking*: The major market for natural graphite is in magnesia-carbon and alumina-carbon refractories for the steel industry. According to Roskill, consumption of refractories is around 15 kg per tonne of crude steel worldwide (Roskill 2015). The natural graphite used in refractories is selected for its high-temperature stability and chemical inertness. The important properties are flake size, carbon content and impurity level. Natural flake graphite with large crystals increases the brick mechanical strength. Amorphous graphite powder can also be used, mostly for monolithic refractories. Graphite flakes are primarily used in the production of magnesia-carbon bricks (MgO-C) which are used as a lining material in basic oxygen furnace (BOF) and electric arc furnaces (EAF), and in high-wear areas such as slag lines in ladles. The bricks consist of fused magnesia and flake graphite (15-25%) bonded with synthetic resin. Large flakes (>150 micrometre) with a carbon content of at least 85% are preferred. Alumina-carbon refractory shapes, which contain between 5% and 15% graphite, are used as functional components (e.g. stopper rods and ladle shrouds) in continuous steel casting operations. Magnesia-carbon and alumina-carbon refractories require natural graphite with a particle size larger than 150 µm (100 mesh) and purity between 87% to 90%, and 95% to 99% respectively;

- Foundries*: In foundries, natural graphite-based coatings and washings are employed as facings to protect from erosion refractory linings, troughs and other equipment that convey molten metal, as well as to ease the release of cast products from moulds. Furthermore, graphite is the main component in the manufacture of clay-bonded crucibles to handle molten metal. The mix contains up to 60% graphite. Finally, natural graphite powders are used as a cover of molten metal (e.g. copper and copper alloys) to prevent oxidation of the melt. Amorphous graphite is preferred due to a lower cost for foundry applications, but also fine-grained, low-grade flake graphite can be used. Large-sized flake graphite provides a longer service life of graphite crucibles;

- Batteries*: Due to its high electrical conductivity, inertness and reversible Li-ion intercalation between the basal planes of the crystal structure, flake graphite is a critical component of primary and rechargeable batteries, i.e. in cathodes of alkaline batteries as an additive, in anodes and cathodes of lead-acid batteries as an additive, in anodes of Li-ion batteries (LIB) as the main material. In 2015, Li-ion batteries accounted for about 75-85% and alkaline batteries for around 10-15% of the total graphite demand for batteries, and the remainder was covered by lead-acid and other battery types (Roskill 2015). Li-ion batteries contain significant amounts of graphite in comparison to lithium, e.g. it takes 10 to 20 times more graphite than lithium, depending on the cathode used, to make a Li-ion battery (Leguérinel and Le Gleuher 2017). Flake natural graphite is the precursor to the

battery-grade quality for Li-ion anodes known as spherical graphite. Spherical graphite consists of high purity (>99.95% C and absence of metallic impurities) rounded particles with typical sizes in the range of 10-25  $\mu\text{m}$ . The spheroidal shape of the particles improves compaction and density within the battery compartment, which increases the energy and recharge capacity of the Li-ion batteries. In comparison to available carbon-based active materials (synthetic graphite, amorphous carbon, Si-C composites etc.), natural graphite had a global market share of 46% in 2016 (Pillot 2017) and 39% in 2017 (Pillot 2018);

- *Friction products*: Due to its high natural lubricity, natural graphite powders are added in the manufacture of high-temperature dry lubricants and oil and water dispersions for use under conditions of extreme friction and heat, such as in heavy machinery, seamless tube rolling mills etc. Amorphous and flake graphite are commonly used with a carbon content of more than 98 %. The graphite content of the lubricants varies between 5 and 10 % depending on the application;

- *Lubricants*: Because of its high thermal conductivity, thermal stability and lubrication properties, natural graphite is a critical component of friction linings as it provides heat dissipation and effective lubrication at the friction interface. Friction applications include brake and clutch linings used by the automotive, aviation and rail industries. The natural graphite used has to be of high purity (close to 99.9 %);

- *Recarburising*: Amorphous graphite is used as a source of carbon to raise the carbon content of molten steel (recarburising), as well as in grey and ductile iron in ferrous foundries;

- *Pencils*: Natural graphite mixed with clay has been used in pencil leads since a long time ago, due to its softness, non-toxicity and black streak. Flake graphite is favoured for higher quality in pencils;

- *Graphite shapes*: Purified and micronised graphite is an essential additive in metal powder mixtures for the fabrication of sintered parts, mainly for automotive applications. Graphite provides internal lubrication making maximum compression possible, as well as increased mechanical strength after sintering.

- *Electrical applications*: Electrical conductivity and lubricity allow natural graphite's use in electrical applications, i.e. in the manufacture of brushes for electric motors and other current-carrying carbon products, to effectively transfer electric current and minimise frictional wear. Vein graphite is chosen for high-quality applications because of its purity and crystallinity;

- *Flame-retardants*: Expandable graphite has an efficient flame-retardant effect as it swells up when exposed to heat, thus isolating the fire from the material underneath or sealing a gap. Applications include the use of expandable graphite in plastics, coatings, insulation foams (e.g. PU plates), textiles, firestops for buildings and constructions etc.;

- *Pebble-bed nuclear reactors*: Due to its low absorption of X-rays and neutrons, high thermal conductivity and ability to maintain these properties at high temperature, graphite is used as a neutron moderator in emerging pebble-bed nuclear reactors (PBNRs);

- *Fuel cells*: Purified flake graphite and purified expanded flake graphite can be used as the main filler material in bipolar plates for fuel cells. In particular, natural graphite makes up the anode and cathode material of Proton Exchange Membrane (PEM) fuel cells used in transport and stationary energy storage (Roskill, 2015);

- *Other*: Finally, natural graphite is employed in a high number of other applications such as seals and gaskets made of graphite foil for high-temperature applications, additive in insulation foams (e.g. EPS) for enhanced heat reflection, drilling mud additives, equipment to handle molten glass, heat insulation panels, additives for improving tribological and conductive characteristics of plastics, etc.

### 16.3.3 Substitution

Synthetic graphite and natural graphite are competing in various applications. They are commonly substituted for each other, or blends containing both types are prepared by manufacturers (Robinson, Hammarstrom, and Olson 2017). The choice of the substitute is mostly driven by the relative price, carbon grade and particle size and shape.

Substitution is also a function of raw material availability and product performance that can be specific to each end use (Roskill 2015).

Synthetic graphite can be made from calcined petroleum needle coke, a by-product of the petroleum industry, coal tar pitch or other carbon-containing precursors (Asbury Carbons, 2019). The higher costs associated with the production of synthetic graphite in comparison to natural graphite mining are somewhat offset by the costs of purification to raise natural graphite's grade (Roskill 2015). In general, synthetic graphite has an advantage over natural graphite in applications which require the highest carbon grades and the lowest level of impurities, such as batteries and graphite shapes. Natural amorphous graphite is the preferred material in a lower grade or lower value applications, or where the use of graphite as a powder is beneficial (Roskill 2015). Alternative substitutes for graphite in some applications are typically other forms of carbon such as the secondary synthetic graphite recovered from discarded foundry and other carbon-containing materials (Robinson, Hammarstrom, and Olson 2017).

The substitution in the criticality assessment was considered in detail for refractories for steelmaking and foundry applications. The other end uses were not included in the evaluation due to a lower than 10% share. In particular:

- **Refractories.** Refractories for steelmaking is one application in which there is no competition by synthetic graphite (Leguérinel and Le Gleuher 2017), (Tercero et al. 2015). The flaky shape of natural graphite is beneficial to the structure of the final refractory product, whereas the higher porosity of synthetic graphite (10-15% compared to 2-3% for natural graphite) makes it unsuitable for most refractory applications. When synthetic graphite is used in some refractory applications, firing at temperatures approaching 2,000 C° are required to form a dense graphite structure, but the refractories have low oxidation resistance and cannot be readily exposed to air, water vapour and carbon dioxide at high temperatures. Besides, the cost of processing natural graphite is not high because the carbon grades (85-99% C) required by refractories can be achieved by basic processing methods (Roskill 2015). In crucible production, graphite can be substituted by silicon carbide, but with lower performance (Tercero et al 2015);
- **Foundry applications.** Synthetic graphite powder, finely ground coke with olivine, talc, mica or zircon may be used as the substitutes in foundry-facing applications (Tercero et al. 2018), (USGS 2019b).

Concerning the rest of the applications, the following potential substitutes are listed:

- **Batteries.** Spheroidal graphite used in anodes of Li-ion batteries is either manufactured from synthetic or natural graphite. Secondary synthetic graphite from machining graphite components is also an available substitute (Tercero et al. 2015), (USGS 2019b). The main area of competition between natural and synthetic graphite is currently in anode materials for Li-ion batteries, and some manufacturers even use mixtures of natural and synthetic graphite in the anode. If the price of battery-grade natural graphite increases to parity with the price of synthetic graphite, then increased uptake of synthetic graphite as a substitute in Li-ion batteries can be anticipated (Roskill 2015). In terms of anode technology, silicon-graphite chemistries, which enable higher power densities, are expected to become available soon (Bunsen et al. 2019);
- **Lubricants.** Natural graphite can be substituted by synthetic graphite. Also, molybdenum disulphide competes with natural graphite as a dry lubricant but is prone to oxidation (Tercero et al. 2015), (USGS 2019b), (Roskill 2015);
- **Friction materials and carbon brushes.** Synthetic graphite can be used instead of natural graphite (Roskill 2015);
- **Recarburising.** High-carbon scrap from discarded graphite shapes and calcined petroleum coke can substitute the use of natural graphite to increase the carbon content in molten iron and steel (Tercero et al. 2015), (USGS 2019b). Substitution with synthetic graphite is also possible, but not applied in practice because of the higher costs (Roskill 2015);

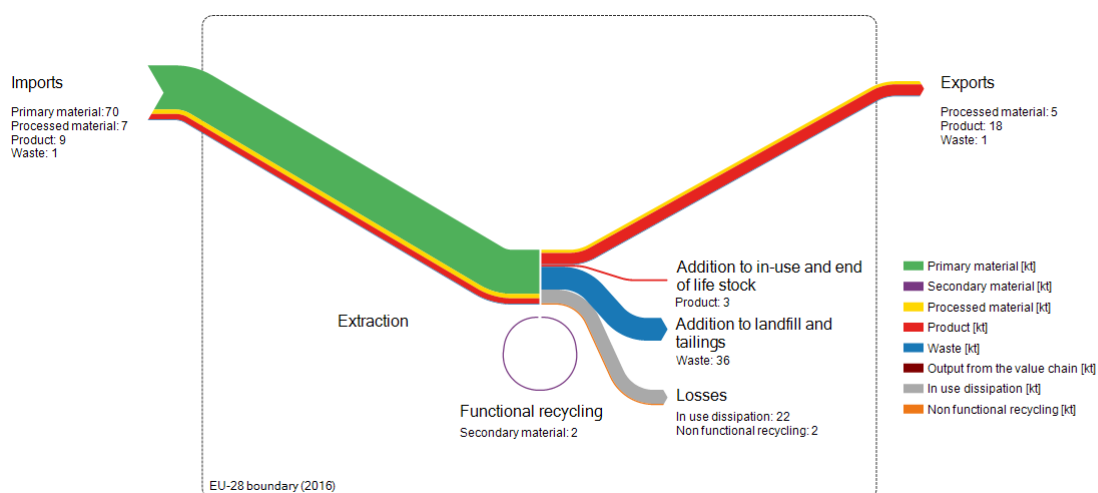


•Fire-proofing materials, seals and gaskets etc. Synthetic graphite does not compete with natural graphite in applications using expandable natural graphite (Roskill 2015).

## 16.4 Supply

### 16.4.1 EU supply chain

Figure 202 shows the simplified Sankey diagram for natural graphite flows for the year 2012.

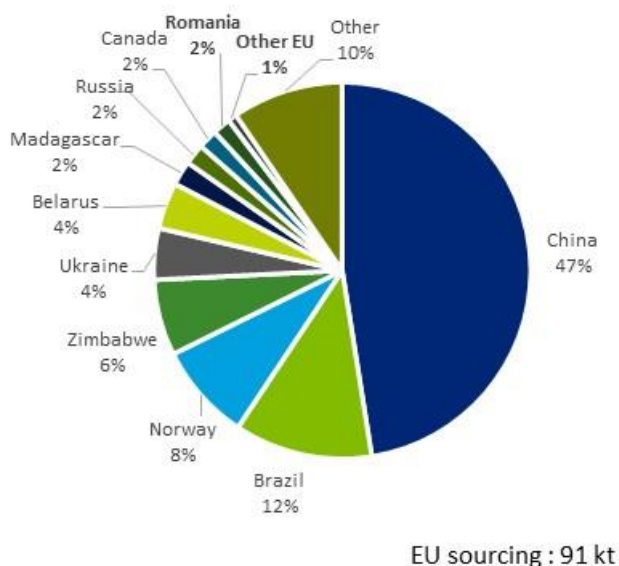


**Figure 202: Simplified MSA of natural graphite flows in the EU in 2016 (Draft natural graphite MSA 2019)**

#### 16.4.1.1 EU sourcing of natural graphite

The EU production was about 2,080 tonnes as an average over 2012-2016 accounting for only 0.2% of the global output. Currently, there are two active underground mines in the EU: the Kaisersberg mine in Austria (Grafitbergbau Kaisersberg GmbH) which produces amorphous graphite, and the Kropfmühl mine (Graphit Kropfmühl, a subsidiary of AMG Advanced Metallurgical Group) in Germany which recommenced operation in 2012 and produces flake graphite. The Woxna flake graphite open-pit mine in Sweden, operated by Leading Edge Materials Corp, began production in early 2015 but suspended a few months later due to low prices; since then the installation is maintained on a production-ready basis. In Romania, graphite deposits were exploited in the past, e.g. the Catalinul and Ungurelaşu mine (Lauri et al. 2018). According to reported statistics by (WMD 2019), natural graphite's production in Romania concluded in 2012, whereas according to statistics published by the British Geological Survey mining of natural graphite in Romania ceased in 2010 (BGS 2019).

Figure 203 presents the EU sourcing (domestic production + imports) for natural graphite averaged over the period 2012–2016. The EU is dependent on imports for its consumption of natural graphite, with an import reliance of 98%.



**Figure 203: EU sourcing of natural graphite. Average 2012-2016, (Eurostat, 2019), (WMD, 2019)**

#### 16.4.1.2 EU sourcing of processed/refined natural graphite

Processing capacity for the refining of natural graphite exists in the EU, for example:

- The *Graphite Týn* plant in Czechia (AMG group) produces purified, micronised, and expandable natural graphite (AMG GK 2019);
- The *Sundsvall* plant in Sweden, through a proprietary electro-thermal treatment and purification process, produces purified graphite for recarburisers, melt covers in foundries, friction materials, and polymer additives (Superior Graphite 2019);
- The *Kaisersberg* plant in Austria produces micronised graphite, and other refined graphite products such as expandable graphite (Grafitbergbau Kaisersberg 2019);
- Graphit *Kropfmühl* (AMG group) operates two plants in Germany to process crude natural graphite and fabricate graphite products such as graphite dispersions, lubricants and graphite parts. Refined natural graphite products include expandable and expanded graphite (Kropfmühl 2019), (Roskill 2015);
- SGL *Carbon* produces speciality and downstream graphite products based on processed natural graphite such as components made of high-purity fine grain graphite for silicon crystals production, expanded and flexible graphite. Producing sites for graphite materials are located in Germany (Bonn, Limburg, Meitingen), France (Grenoble, Chedde), Spain (Madrid), Italy (Verdello), Poland (Nowy Sacz, Racibórz), (SGL Carbon 2019), (Roskill 2015).
- In the Netherlands (Maastricht), *Asbury Carbons* processes graphite for end-use products since 2014, e.g. flake graphite with purity up to 99.9% (Asbury Carbons 2019) (Roskill 2015);
- Sinograf in Poland supplies natural flake and amorphous graphite for refractories and foundries along with a range of intermediate and downstream products including graphite micro powders, expanded graphite and flexible graphite products etc. (Sinograf 2019).

However, at present, there is no production capacity for spherical graphite in the EU. The company (Leading Edge Corp) holding the Woxna mine, Sweden, is currently (2019) working for a graphite processing plant which would produce spherical, battery-grade graphite and other forms of processed graphite at the mine site (Leading Edge 2019a), (Leading Edge 2019b). Moreover, according to announcements made by the owning

company (Talga Resources Ltd) of the Vittangi mine development project in Sweden, the concentrate of the mining operation will be refined to a coated lithium-ion battery graphite anode material (Talga Resources 2019).

#### **16.4.1.3 Recycled natural graphite supply**

Recycling and processing of spent graphite-based refractories started more than thirty years ago in the EU. Recycled materials are used in some applications as a full or partial replacement to virgin materials such as in monolithic and shaped refractories (European Commission 2017). The end-of-life recycling input rate was estimated at 3% in 2012 (BIO Intelligence Service 2015), as well as in 2016 (Draft MSA 2019).

Currently there is no scale for specific Li-ion battery recycling that would embark on dismantling the battery, instead of using graphite as a heat source in the pyrometallurgical process (Euromines 2019). Recovery of graphite from spent lithium batteries is foreseen at the Accurec Recycling GmbH facility in Krefeld, Germany, after a planned investment in thermal deactivation and treatment (Recharge 2018).

### **16.4.2 Supply from primary materials**

#### **16.4.2.1 Geology, resources and reserves of natural graphite**

**Geological occurrence:** No specific information is available for the crustal abundance of natural graphite. The average carbon abundance of the earth's crust is estimated at 200 ppm distributed between organic compounds, hydrocarbons, coal and mineral forms (diamonds, graphite, carbonate rocks). Natural graphite deposits are generally a result of metamorphism of sedimentary rocks (e.g. marble, schist, and gneiss) rich in carbonaceous material. The ore type is classified as amorphous, flake or vein graphite according to the degree of crystallisation, grain-size, and morphology which are determined by the geologic setting (Robinson, Hammarstrom, and Olson 2017) (BRGM 2012).

Deposits of amorphous graphite are formed from the metamorphism of highly carbonaceous sediments, usually coal beds. The orebody consists of layers, seams, and lenses, each a few meters thick and hundreds of meters to several kilometres in length. The average commercial ore grade varies from 50 to 90 % carbon, higher than flake graphite; the raw ore and the commodity may contain non-graphitic carbonaceous material in addition to graphite. China and Russia/Ukraine hold the most abundant resources globally. Other deposits are located in the People's Republic of Korea and Mexico. According to the USGS estimates, approximately half of the total identified resources worldwide are amorphous graphite (Robinson, Hammarstrom, and Olson 2017). Amorphous graphite production accounted for 35% to 40% of the world mine production in 2014 (BRGM 2016).

Flake graphite is found as disseminated, plate-like particles that crystallised in the carbonaceous metamorphic rock. The body of the ore occurs in tabular form or lenses, as much as 33 m thick and thousands of meters long; the ore grade is low, on average between 5 and 30 % graphitic carbon. The most significant flake graphite deposits are located in China, Russia/Ukraine (e.g. the Zavalyevskiy deposit in Ukraine), and Mozambique (e.g. the Balama deposit) where major mine development projects are underway; total resources and reserves in Mozambique amount to 342 million tonnes in graphite content (S&P Global, 2018). Important flake graphite deposits also exist in Madagascar, Brazil, India and Canada. In 2014, flake graphite accounted for 60-65 % of world production (BRGM 2016).

The vein or lump graphite occurs in thin veins in igneous and high-grade metamorphic rocks formed by deposition from high-temperature fluids. Vein graphite deposits are

significant for the low level of impurities and the high degree of crystallinity. It is commercially extracted only in underground mines in Sri Lanka with average graphitic carbon in the range 60-95%. Vein graphite global reserves represent only 0.1% of the total, and in 2014 vein graphite accounted for 0.3% of the global natural graphite production.

Graphite is a common mineral in metamorphic rocks throughout Europe, however it is rare to find economically interesting deposits. The bulk of the graphite occurrences occur in Northern Europe and Ukraine, and a number of amorphous graphite occurrences are also found in Austria. The Trælen deposit in Norway is the world's richest graphite deposit in production with an average ore grade of 31%, and 1,800 kt proven reserves (Gautneb et al. 2019).

**Global resources and reserves**<sup>168</sup>: According to the United States Geological Survey (USGS), the world's inferred resources exceed 800,000 kt of recoverable graphite. Besides, USGS estimates world reserves at 270,000 kt at the end of 2017 (USGS 2018a). However, this figure is not used in this factsheet, as reported reserves by some countries are expressed in volume of graphite ore (and not in graphite content)<sup>169</sup>. Compared to other industrial minerals, individual deposits of natural graphite are not well documented in terms of tonnage or grade, and country totals are often largely estimated (Roskill 2015).

World reserves of natural graphite are estimated at around 110,000 kt of graphite content (Table 87).

**Table 87: Global reserves of natural graphite in 2017. Background data in (Robinson, Hammarstrom, and Olson 2017) (USGS 2018a)**

Country	Estimated natural graphite reserves (kt of recoverable graphite content)	Percentage of the total (%)
China	55,000	50%
Mozambique	17,000	15%
Tanzania	17,000	15%
Russia <sup>170</sup>	4,500	4%
Mexico	3,100	3%
Ukraine <sup>6</sup>	2,900	3%
Sri Lanka	1,850	2%
North Korea	1,700	2%

<sup>168</sup> There is no single source of comprehensive evaluations for resources and reserves that apply the same criteria to deposits of graphite in different geographic areas of the EU or globally. The USGS collects information about the quantity and quality of mineral resources but does not directly measure reserves, and companies or governments do not directly report reserves to the USGS. Individual companies may publish regular mineral resource and reserve reports, but reporting is done using a variety of systems of reporting depending on the location of their operation, their corporate identity and stock market requirements. Translations between national reporting codes are possible by application of the CRIRSCO template, which is also consistent with the United Nations Framework Classification (UNFC) system. However, reserve and resource data are changing continuously as exploration and mining proceed and are thus influenced by market conditions and should be followed continuously.

<sup>169</sup> The USGS (USGS, 2018a) reports 70,000 kt for natural graphite reserves in Brazil and 90,000 kt in Turkey. However, according to the 2014 Brazilian Minerals Yearbook (<http://www.anm.gov.br/dnpm/paginas/sumario-mineral>), graphite reserves are 72,000 kt of ore, and according to the Turkish Statistical Survey (<http://www.mapeg.gov.tr/Istatistik.aspx>), graphite reserves are 90,000 kt of ore at 6-17% C.

<sup>170</sup> Total reserves of 7,400 t are reported jointly for Russian Federation and Ukraine by USGS (2017). The split is based on the assumption that reserves are proportional to the mine production of 2016

Country	Estimated natural graphite reserves (kt of recoverable graphite content)	Percentage of the total (%)
Madagascar	1,600	1%
Canada	1,500	1%
Other countries	3,850	4%
World total (rounded)	110,000	

**EU resources and reserves**<sup>171</sup>: The most important natural graphite deposits in the EU and their associated resources and reserves are summarised below:

- In Sweden, the Woxna deposit contains NI 43-101 compliant estimated total resources of 9,700 kt of ore at 9.1% graphitic C (Flinders Resources 2015). The Vittangi (Nunasvaara), Raitajärvi and Jalkunen deposits currently have JORC-compliant mineral resource estimates, with Nunasvaara containing 12,300 kt of ore with a very high ore grade of 25.5% graphitic C, Raitajärvi containing 4,300 kt of ore at 7.1% graphitic C, and Jalkunen containing 31,500 kt of ore at 14.9% graphitic C (Talga Resources 2018). Reserves are announced at 1,900 kt of ore at 23.5% of graphitic C (Talga Resources 2018);
- In Finland, the Aittolampi flake graphite deposit is under exploration comprising a JORC-compliant total resource estimate of 19,300 kt of ore at 4.5% graphitic C (Beowulf Mining 2018);
- In Austria, proved ore reserves of 160 kt and mineral resources of 1,500 kt are reported for the Kaisersberg deposit (Lauri et al. 2018);
- In Czechia, eight graphite deposits are registered by the national authorities of amorphous (Velké Vrbno-Konstantin, Bližná-Černá v Pošumaví, Český Krumlov-Rybářská ulice, Velké Vrbno-Luční hora 2), flake graphite (Český Krumlov-Městský vrch, Lazec-Krenov, Koloděje nad Lužnicí-Hosty) and mixed (amorphous and flake) (Spolí) (Czech Geological Survey 2017).

Table 88 and Table 89 present data on resources and reserves of natural graphite in the EU.

**Table 88: Natural graphite resources data in the EU**

Country	Classification	Quantity (Mt of ore)	Grade (%)	Reporting code	Reporting date	Source
Austria	None	1.5	NA	NA	02/2018	(Lauri et al. 2018)
Czechia	Economic explored	2.981	NA	National reporting code	12/2016	(Czech Geological Survey 2017)
	Economic prospected	4.935				

<sup>171</sup> For Europe, there is no complete and harmonised dataset that presents total EU resource and reserve estimates for natural graphite. The Minerals4EU project is the only EU-level repository of some mineral resource and reserve data for natural graphite, but this information does not provide a complete picture for Europe. It includes estimates based on a variety of reporting codes used by different countries, and different types of non-comparable datasets (e.g. historic estimates, inferred reserves figures only, etc.). In addition, translations of Minerals4EU data by application of the CRIRSCO template is not always possible, meaning that not all resource and reserve data for natural graphite the national/regional level is consistent with the United Nations Framework Classification (UNFC) system (Minerals4EU 2019). Many documented resources in Europe are based on historic estimates and are of little current economic interest. Data for these may not always be presentable in accordance with the UNFC system. However a very solid estimation can be done by experts.

	Potentially economic	5.785				
Greece	None	0.024	6	NA	02/2018	(Lauri et al. 2018)
Finland	Measured	-	-	JORC	08/2018	(Beowulf Mining 2018)
	Indicated	7.3	4.7 (TGC)			
	Inferred	12	4.4 (TGC)			
Slovakia	Historic Resource Estimates	0.29	3.4	None	11/2014	(Minerals4 EU 2019)
Sweden	Measured	-	-	JORC	06/2018	(Talga Resources 2018)
	Indicated	14.1	21.26 (TGC)			
	Inferred	34	15.1 (TGC)			
Sweden	Measured	1.0	10.7 (TGC)	NI 43-101	03/2015	(Flinders Resources 2015)
	Indicated	6.8	9.1 (TGC)			
	Inferred	1.9	8.5 (TGC)			
Sweden	Historic Resource Estimates	8.45	9.05	None	11/2014	(Minerals4 EU 2019)

**Table 89: Natural Graphite reserves data in the EU**

Country	Classification	Quantity (million tonnes of ore)	Grade (%)	Reporting code	Reporting date	Source
Austria	Proven	0.16	NA	NA	02/2018	(Lauri et al. 2018)
Sweden	Probable	1.94	23.53	JORC	05/2019	(Talga Resources 2019)

#### 16.4.2.2 Exploration and new mine development projects in the EU

An increasing number of exploration companies is developing new graphite projects worldwide. In the EU the activity is concentrated in Sweden and Finland:

- The most advanced project for commercial production is the Vittangi project in Sweden owned by the Australian company Talga Resources Ltd (Talga Resources 2019). The preliminary Feasibility study has been completed, and initial production is expected in early 2021. Other exploration activities at a more advanced stage in Sweden are identified for the Jalkunen and Raitajärvi projects by the same company (Talga Resources 2018).

- The Aitolampi project in Finland has concluded the estimation of a maiden resource and a scoping study for a preliminary assessment of the technical and economic feasibility of developing a mining operation at the project is pending (Beowulf Mining 2018).

### **16.4.2.3 Natural graphite mining**

Natural graphites ores are mined from either surface or underground mines depending on the proximity of the ore body to the surface. Most flake graphite deposits are exploited using open-pit mining methods, especially when the ore is intensively weathered; however, underground mining methods are employed in few cases of steeply dipping orebodies with high-grade minable lenses (> 15 % C). Open-pit mining involves conventional drilling and blasting methods for hard rocks or standard soft rock mining techniques. Drift mining, hard-rock mining, shaft mining and slope mining are methods used in underground mines (Robinson, Hammarstrom, and Olson 2017).

The mineral processing of natural graphite for the production of flake graphite and powder concentrates depends on the rock containing the graphite, the ore type and the grade. It varies from a simple hand sorting and screening of high-grade vein graphite and some high-grade amorphous graphite ores to a complex beneficiation process. The main steps in a standard processing route of flake graphite ore are crushing and grinding, followed by flotation and screening:

- Mechanical preparation. It is an essential stage in natural graphite's mineral processing as size and grade are the two commercially important parameters of natural graphite products. The crushing and grinding steps have to be optimised to minimise size reduction of constituent particles (flakes), but simultaneously maximise the liberation of gangue minerals;
- Flotation. Natural graphite is naturally hydrophobic; therefore, it can be upgraded by flotation. A multi-stage flotation process is generally applied. After washing to remove clay materials, the ore is subjected to a first rough flotation followed by secondary grinding and cleaning flotation. The graphitic carbon content of flake graphite concentrate ranges between 85% and 97%. A highly concentrated grade with few impurities is desirable for further refining as it lowers the purification costs;
- Screening. The concentrate is then dried, screened and classified to a variety of products of various sizes. Commercial flake graphite available for end-uses or further processing is available in distinct sizes e.g. jumbo (+50 mesh, i.e. >300 µm), large (-50+80 mesh, i.e. 180-300 µm), medium (-80+100 mesh, i.e. 150-180 µm), fine (-100 mesh, i.e. < 150 µm). Different classifications are possible.

The marketed products of natural graphite are classified by purity and particle size in three distinct categories:

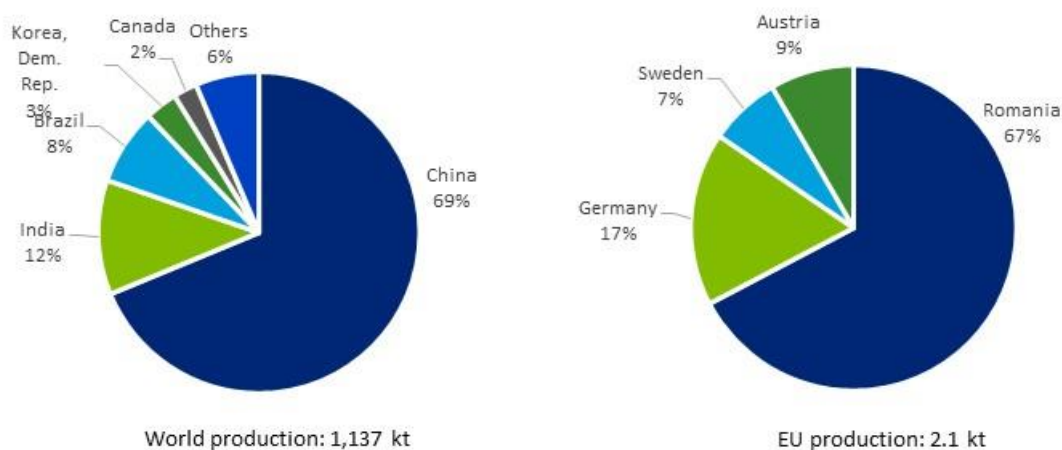
- Amorphous graphite: It consists of grains with a tiny crystal size (microcrystalline graphite). Amorphous graphite is the most abundant but least pure commercial type of natural graphite. Typical commercial purity varies between 80-85 % graphitic C. Amorphous graphite is the lowest valued quality of natural graphite.
- Flake graphite: It is coarse-grained crystalline graphite that consists of platelets of graphite layers (flakes). Flake graphite is of higher quality than amorphous graphite and has the broadest range of end uses. Commercial purity ranges from 85 % up to 97 % graphitic C. Flake graphite is marketed in different sized flakes (small, medium, large, jumbo), ranging between 40 µm and 1 cm in size.
- Vein or lump graphite: It occurs in nature at the highest purity, grain size and crystallinity of the natural graphite extracted commercially. Vein graphite is the rarest form and the premier quality of natural graphite. Vein graphite is suitable for many flake

graphite’s applications with a preference for high-performance speciality products. It is produced in limited tonnages at a high grade (94 % to 99.5 % graphitic C).

#### 16.4.2.4 World and EU mine production

Natural graphite ore production data vary greatly depending on the source and should be viewed with caution, as some countries may report tonnages of concentrates and others of run-of-mine ore. The figures provided by World Mining Data (WMD 2019) and the United States Geological Survey (USGS 2018b) are close to one million tonnes per year. According to (WMD 2019), the annual production of graphite concentrates amounted to about 1,137 kt on average between 2012 and 2016. As shown in Figure 204, China is the world-leading supplier with a share of 68% (782 kt) of the total global production, while India (131 kt per year), Brazil (83 kt per year), North Korea (37 kt), and Canada (27 kt) collectively made up 25% of the worldwide output. However, according to the British Geological Survey, the output figures noted above for India refer to crude ore, and the figures for Brazil include beneficiated and directly shipped material. Moreover, according to Benchmark Minerals data in (Leguérinel and Le Gleuher 2017), in 2014 the production of natural graphite in China is around 400 kt and the production in India close to 20 kt. The analysis made by the French Geological Survey (BRGM) in (Leguérinel and Le Gleuher 2017) combining different sources of production statistics, provides a figure for the world production in 2014 of 633 kt.

In the EU, during the 2012-2016 period natural graphite was mined in Austria, Germany, Romania and Sweden accounting for about 2 kt (WMD 2019), equivalent to around 0.2% of the global output.



**Figure 204: Global and EU mine production of natural graphite. Average for the years 2012-2016. Data from (WMD 2019)**

#### 16.4.3 Processing/refining of natural graphite

The natural graphite concentrate can be subjected to chemical and thermal treatments to achieve a grade of higher purity (C content of over 99%) and optimise the combination of physical and chemical properties for particular applications. Many of these processes require the use of strong reagents, high temperatures and large energy consumption (Roskill 2015). Processed natural graphite products are intermediates for the manufacture



of a wide range of value-added products for speciality technical applications. The refined forms of natural graphite can be distinguished in the following types:

- *Purified graphite*. The most common technique to refine the natural graphite after flotation is acid leaching. Various acids (e.g. HCl, HF, H<sub>2</sub>SO<sub>4</sub>, HNO<sub>3</sub>) or mixtures of them are used depending on the type of the impurities in the graphite. Acid leaching is an effective technique to remove silicate impurities. When the graphite concentrate also contains sulphur, both silicates and sulphides are effectively eliminated by a combined roasting-leaching process, which can produce graphite with 99.99 % purity. Purified natural graphite can also be produced by thermal purification at high temperatures;

- *Expandable and flexible graphite*. Expandable graphite is made by chemical treatment of large-sized flake graphite with intercalating compounds (e.g. acid-based S and N compounds) at room temperature, to achieve graphite intercalation, i.e. introduction of atoms or small molecules between the planar carbon layers. The intercalated flakes are then washed and dried to remove residual elements. Under the influence of heat, the intercalating compounds vaporise which results in high inter-layer pressure causing the exfoliation (expansion) of individual graphite flakes and the increase in volume by several hundred times (150 to 300 times or even higher). The properties of expandable graphite, i.e. onset temperature of expansion and expansion volume, are determined by the quality of intercalation (proportion of intercalated layers) and by the intercalation agent. Expanded graphite is produced after thermal treatment of expandable graphite. Flexible graphite (or graphite foil) is made by rolling and compressing expanded graphite into thin sheets;

- *Spherical graphite*. It is the battery-grade graphite in anodes of Li-ion batteries. Fine and medium-flake graphite are typically used to produce spherical graphite. Spherical graphite is produced with stringent quality requirements from high-carbon flake graphite by successive stages of mechanical milling (micronising), spherodisation, purification to above 99.95% C, and coating with carbon. The process increases the surface area and conductivity making it highly suitable for use as anode material. Spherical graphite production yields generally ranges from 30% to 40% of the initial weight of the feed flake material (BRGM 2012). The fine by-products of the process can be marketed for low-value uses of amorphous graphite. The purified spherical graphite can be marketed either uncoated or coated.

#### **16.4.3.1 World and EU refined natural graphite production**

No statistical data are available for the production of value-added downstream products such as high-purity graphite, expandable/expanded graphite, and spherical graphite. Currently, China is practically the only global producer of spherical graphite worldwide producing in excess of 100 kt in 2018 for use in lithium-ion battery anode material (Roskill 2019c).

#### **16.4.4 Supply from secondary materials/recycling**

Recycling of graphite from end-of-life products is limited as a significant amount is dissipated during use, e.g. lubricants, pencils, friction pads, foundry washes, carbon brushes and, to some extent, refractories. Besides, recycling of graphite from end-of-life products is inhibited by its relative abundance in nature and lack of economic incentive due to the prevailing low prices (USGS 2019b), (European Commission 2017).

Potential secondary resources for natural graphite from end-of-life products include refractories, batteries and brake pads:

- Recycling of graphite from spent refractories is feasible through a process of crushing, pulverising, iron and slag removal, and separation by sieving (Sundqvist Ökvist et al. 2018). The market for graphite recycling from used refractories such as magnesia-carbon bricks and alumina-carbon shapes is reported to be growing, and the recovered material can be recycled into brake linings and thermal insulation (USGS 2019b) or monolithic and shaped refractories (European Commission 2017);
- Currently, there is no reported industrialised process to recycle graphite from the spent lithium-ion batteries (Sundqvist Ökvist et al. 2018). Recycling of batteries does not target graphite, which is oxidised to CO<sub>2</sub> during pyrometallurgical processes. However, in hydrometallurgical processes, the recovery of graphite is technically feasible (Mathieux et al. 2017).
- Friction liners for vehicle brakes are only used to approximately 50% prior to their replacement. These spent materials usually are disposed of as hazardous waste or partially smelted to low quality steel. It has been demonstrated that recycled friction liners can be used to produce new friction liners; thus, the graphite in the liners is recycled as well (Sundqvist Ökvist et al. 2018).

Recycling of end-of-life products is a minor source of natural graphite supply. It is estimated, that in 2016, only 3% (EOL-RIR) of the EU annual supply of natural graphite is sourced from end-of-life scrap (Draft MSA 2019).

**Table 90: Material flows relevant to the EOL-RIR of natural graphite<sup>172</sup> in 2016. Data from (Draft MSA 2019)<sup>173</sup>**

MSA Flow	Quantity (t)
B.1.1 Production of primary material as main product in EU sent to processing in EU	652
B.1.2 Production of primary material as by-product in EU sent to processing in EU	0
C.1.3 Imports to EU of primary material	0
C.1.4 Imports to EU of secondary material	0
D.1.3 Imports to EU of processed material	77,310
E.1.6 Products at end of life in EU collected for treatment	22,049
F.1.1 Exports from EU of manufactured products at end-of-life	189
F.1.2 Imports to EU of manufactured products at end-of-life	220
G.1.1 Production of secondary material from post-consumer functional recycling in EU sent to processing in EU	0
G.1.2 Production of secondary material from post-consumer functional recycling in EU sent to manufacture in EU	2,183

## 16.5 Other considerations

### 16.5.1 Environmental and health and safety issues

Natural graphite is inert and non-toxic (Leguérinel and Le Gleuher 2017), and it is not subject to restrictions by the REACH regulation (ECHA 2019).

<sup>172</sup>  $EOL-RIR = (G.1.1 + G.1.2) / (B.1.1 + B.1.2 + C.1.3 + D.1.3 + C.1.4 + G.1.1 + G.1.2)$

<sup>173</sup> The work carried out in 2019 increased the resolution of the MSA system. Therefore, there are changes in flows in comparison with the previous MSA methodology. B1.1 and B1.2 in the table is the result of the EU extraction after exports (MSA flows B1.1 + B1.2 – B1.3); C1.4 incorporates all secondary raw material imported to the EU both for the processing and manufacturing stages (MSA flows C1.4 and D1.9). D1.3 Incorporates imports to the EU of both semi-processed and processed material stages (MSA flows D1.3 and C1.8).

## 16.5.2 Contribution to low-carbon technologies

Graphite is the reference material used in the anodes of Li-ion batteries for hybrid, plug-in hybrid and battery-electric vehicles, as well as in Li-ion and lead-acid batteries for energy storage systems. Graphite in the anode can be either natural, in the form of a highly-processed spherical type, or synthetic (see section 16.3.2 and 16.3.3). The future role of electric vehicles in transport decarbonisation is widely acknowledged and documented, particularly if their deployment is coupled with a low-carbon intensity of electricity generation (European Commission 2018), (Bunsen et al. 2019). The energy storage infrastructure is considered essential to maintain a more flexible energy system and sustain the development of intermittent renewable energy sources, especially wind and solar (Tercero 2019). Finally, graphite is the primary filler material in bipolar plates for fuel cells. Purified flake graphite and purified expanded flake graphite can be used; in 2014 natural graphite accounted for 90% of the global market of graphite for fuel cells (Roskill 2015).

## 16.5.3 Socio-economic issues

China is the leading supplier of natural graphite, both to EU and globally. The level of governance in China is, on average, low, mainly due to the low score in the governance dimension of “voice and accountability” (World Bank 2018).

## 16.6 Comparison with previous EU assessments

The assessment has been conducted using the same methodology as for the 2017 list. The supply risk has been analysed at the extraction stage of the value chain (i.e. natural graphite concentrates), using both the global HHI and the EU-28 HHI, similar to the 2017 assessment. The ‘refining stage’ was not assessed due to the lack of published statistics for the production of the different forms of value-added processed graphite products, and the non-existence of specific trade codes for these products.

The result of the current and earlier assessments are presented in Table 91.

**Table 91: Economic importance and supply risk results for natural graphite in the assessments of 2011, 2014, 2017, and 2020 (European Commission 2011);(European Commission 2014); (European Commission 2017)**

Assessment	2011		2014		2017		2020	
Indicator	EI	SR	EI	SR	EI	SR	EI	SR
Natural Graphite	8.7	1.3	7.4	2.2	2.9	2.9	3.2	2.3

A revised methodology was introduced in the 2017 assessment of critical raw materials in Europe; therefore, the results with the previous assessments in 2011 and 2014 are not directly comparable, e.g. the significant decrease in EI from 2014 to 2017. The 2017 exercise considered natural graphite applications only, whereas, in the 2014 assessment, the calculation of the economic importance was based on natural graphite, and synthetic graphite applications.

In the current assessment, the supply risk indicator results differ from the 2017 assessment due to a decrease in the EU supply risk component of the indicator. In particular, the EU imports of natural graphite in years 2012-2016 have diversified and extended to more countries of origin in comparison to the 2010-2014 period. The share of

China in the EU sourcing has decreased from 66% (average 2012-2016) to 47% (average 2010-2014).

Concerning the economic importance indicator, the higher value in the current assessment is biased by the results scaling step<sup>174</sup>. The value-added of the largest manufacturing sector in the current assessment is lower as it corresponds to 27 Member States (i.e. excluding the UK). In contrast, in the 2017 assessment, it was related to 28 Member States.

## 16.7 Data sources

---

The source of production data for natural graphite was the 'World Mining Data' published by the Austrian Ministry for Sustainability and Tourism and the International Organising Committee for the World Mining Congress, and for trade flows the Eurostat Comext database. The EOL-RIR was calculated from datasets provided by the (Draft MSA 2019). For the end-use sectors, the global distribution was used in the assessment as published by BRGM.

Data on trade agreements are taken from the DG Trade webpages, which include information on trade agreements between the EU and other countries. Information on export restrictions is derived from the OECD database on export restrictions on Industrial Raw Materials.

### 16.7.1 Data sources used in the factsheet

Ait Abderrahim, A. and Monnet, A. (2018) Report on major trends affecting future demand for critical raw materials. SCRREEN project D.2.2. Available at: <http://screen.eu/results/>.

AMG GK (2019) Home - AMG Mining, Advanced Metallurgical Group N.V. Graphite Týn website. Available at: <http://www.gk-graphite.cz/index.php?id=232&L=1> (Accessed: 3 September 2019).

Asbury Carbons (2019) Graphite Material Supplier. Available at: <https://asbury.com/materials/graphite/> (Accessed: 27 October 2019).

Beowulf Mining (2018) Public Announcement. Aitolampi Maiden Mineral Resource Estimate. 13-8-2018. Available at: [https://polaris.brighterir.com/public/beowulf\\_mining\\_plc/news/rns/story/xe5v32x/export](https://polaris.brighterir.com/public/beowulf_mining_plc/news/rns/story/xe5v32x/export).

BGR (2019) Publications and downloads. Commodity prices. Volatility monitoring. Available at: [https://www.bgr.bund.de/EN/Themen/Min\\_rohstoffe/Produkte/produkte\\_node\\_en.html?tab=Commodity+prices](https://www.bgr.bund.de/EN/Themen/Min_rohstoffe/Produkte/produkte_node_en.html?tab=Commodity+prices) (Accessed: 3 September 2019).

BGS (2019) World mineral statistics data, British Geological Survey. Available at: <https://www.bgs.ac.uk/mineralsuk/statistics/wms.cfc?method=searchWMS>.

BIO Intelligence Service (2015) Study on Data for a Raw Material System Analysis: Roadmap and Test of the Fully Operational MSA for Raw Materials. Available at: <https://ec.europa.eu/jrc/en/scientific-tool/msa>.

---

<sup>174</sup> The results are scaled by dividing the calculated EI score by the value of the largest manufacturing sector NACE Rev. 2 at the 2-digit level and multiplied by 10, in order to reach the value in the scale between 0-10.

- BRGM (2012) Panorama 2011 du marché du graphite naturel., BRGM/RP-61339-FR. <http://infoterre.brgm.fr/rapports/RP-61339-FR.pdf>.
- BRGM (2016) 'Le graphite naturel (C) – éléments de criticité'. Bureau de Recherches Géologiques et Minières, p. 401. Available at: <http://www.mineralinfo.fr/page/fiches-criticite>.
- Bunsen, T. et al. (2019) Global EV Outlook 2019. Scaling-up the transition to electric mobility, Global EV Outlook. Available at: [www.iea.org/publications/reports/globalevoutlook2019/](http://www.iea.org/publications/reports/globalevoutlook2019/).
- Czech Geological Survey (2017) Mineral Commodity Summaries of the Czech Republic, 2017 edition (Statistical data to 2016). 25th Edition. Available at: <http://www.geology.cz/extranet-eng/publications/online/mineral-commodity-summaries>.
- Draft natural graphite MSA (2019) Results of the natural graphite MSA Study. Internal document – not published. Reference date: 23 December 2019.
- ECHA (2019) Information on Chemicals. Available at: <https://echa.europa.eu/information-on-chemicals> (Accessed: 12 August 2019).
- ESTAT Comext (2019) Easy Comext database. Available at: <http://epp.eurostat.ec.europa.eu/newxtweb/>.
- Euromines (2019) Comments from Euromines provided to DG GROW following the CRM Ad Hoc Working Group meeting and SCRREEN Experts Workshop. Graphite.
- European Commission (2011) Critical raw materials. Available at: [https://ec.europa.eu/growth/sectors/raw-materials/specific-interest/critical\\_en](https://ec.europa.eu/growth/sectors/raw-materials/specific-interest/critical_en) (Accessed: 8 July 2019).
- European Commission (2014) Report on critical raw materials for the EU - Critical raw materials profiles. Available at: <https://ec.europa.eu/docsroom/documents/11911/attachments/1/translations/en/conditions/pdf>.
- European Commission (2017) Study on the review of the list of critical raw materials. Critical Raw Material Factsheets. European Commission. doi: 10.2873/398823.
- European Commission (2018) In-depth analysis in support of the Commission Communication COM(2018)/773. 'A Clean Planet for all. A European strategic long-term vision for a prosperous, modern, competitive and climate neutral economy'. Available at: [https://ec.europa.eu/clima/sites/clima/files/docs/pages/com\\_2018\\_733\\_analysis\\_in\\_support\\_en\\_0.pdf](https://ec.europa.eu/clima/sites/clima/files/docs/pages/com_2018_733_analysis_in_support_en_0.pdf).
- European Commission (2019) Negotiations and agreements. Available at: <http://ec.europa.eu/trade/policy/countries-and-regions/negotiations-and-agreements/> (Accessed: 7 July 2019).
- Eurostat (2019) Annual detailed enterprise statistics for industry (NACE Rev. 2, B-E). Available at: [https://ec.europa.eu/eurostat/en/web/products-datasets/-/SBS\\_NA\\_IND\\_R2](https://ec.europa.eu/eurostat/en/web/products-datasets/-/SBS_NA_IND_R2) (Accessed: 7 July 2019).
- Flinders Resources (2015) Technical Report for the Woxna Graphite project, central Sweden. Available at: <https://leadingedgematerials.com/woxna-graphite/#1469539847237-0781130e-0897>.
- Gautneb, H. et al. (2019) 'Occurrences of energy critical elements; Lithium – Cobalt and Graphite in Europe, a preliminary overview', SGA 2019 - 15th Biennial Meeting of the Society for Geology Applied to Mineral Deposits. Glasgow, United Kingdom. doi: 10.1016/j.oregeorev.2019.04.015.

- Grafitbergbau Kaisersberg (2019) Graphite qualities. Available at: <https://www.grafit.at/en/selection/> (Accessed: 27 October 2019).
- Kropfmühl, G. (2019) Products & Services. Available at: <https://www.gk-graphite.com/en/products-services/> (Accessed: 27 October 2019).
- Lauri, L. et al. (2018) Identification and quantification of primary CRM resources in Europe. SCRREEN project D3.1. Available at: <http://screen.eu/results/>.
- Leading Edge (2019a) Leading Edge Materials Produces Expandable Graphite In Line With Current Market Products from Woxna, Sweden. Available at: <https://leadingedgematerials.com/leading-edge-materials-produces-expandable-graphite-in-line-with-current-market-products-from-woxna-sweden/> (Accessed: 28 October 2019).
- Leading Edge (2019b) Leading Edge Materials Receives Engineering Study for Battery Graphite Demonstration Plant at Woxna, Sweden. Available at: <https://leadingedgematerials.com/leading-edge-materials-receives-engineering-study-for-battery-graphite-demonstration-plant-at-woxna-sweden/> (Accessed: 28 October 2019).
- Leguérinel, M. and Le Gleuher, M. (2017) Le graphite naturel et synthétique : une offre excédentaire que la demande atone des aciéristes et la progression lente du secteur des véhicules électriques et hybrides ne suffisent pas à réduire, BRGM. Available at: <http://www.mineralinfo.fr/ecomine/graphite-naturel-synthetique-offre-excedentaire-demande-atone-acieristes-progression-lente> (Accessed: 4 September 2019).
- Mathieux, F. et al. (2017) Critical raw materials and the circular economy - Background report. EUR 28832 EN, Publications Office of the European Union, Luxembourg. doi: 10.2760/378123.
- Minerals4EU (2019) European Minerals Yearbook. Available at: [http://minerals4eu.brgm-rec.fr/m4eu-yearbook/theme\\_selection.html](http://minerals4eu.brgm-rec.fr/m4eu-yearbook/theme_selection.html).
- Northern Graphite (2019) Graphite pricing. Available at: <http://www.northerngraphite.com/about-graphite/graphite-pricing/> (Accessed: 28 October 2019).
- OECD (2019) Export Restrictions on Industrial Raw Materials. Available at: [https://qdd.oecd.org/subject.aspx?Subject=ExportRestrictions\\_IndustrialRawMaterials](https://qdd.oecd.org/subject.aspx?Subject=ExportRestrictions_IndustrialRawMaterials) (Accessed: 5 July 2019).
- Pillot, C. (2017) 'The Rechargeable Battery Market and Main Trends 2016-2025. March 2017. Avicenne Energy.' Available at: [http://www.avicenne.com/pdf/Fort\\_Lauderdale\\_Tutorial\\_C\\_Pillot\\_March2015.pdf](http://www.avicenne.com/pdf/Fort_Lauderdale_Tutorial_C_Pillot_March2015.pdf).
- Pillot, C. (2018) 'The Rechargeable Battery Market and Main Trends 2017-2025. June 2018. Avicenne Energy'.
- Recharge (2018) The Batteries Report 2018. Available at: <https://www.rechargebatteries.org/the-recharge-batteries-report-2018-is-online/>.
- Reichl, C., Schatz, M. and Zsak, G. (2019) World Mining Data 2019. Volume 33. Available at: [www.bmnt.gv.at](http://www.bmnt.gv.at).
- Robinson, G., Hammarstrom, J. and Olson, D. (2017) 'Graphite. U.S. Geological Survey Professional Paper 1802-J', in Schulz, K. J. et al. (eds) Critical Mineral Resources of the United States—Economic and Environmental Geology and Prospects for Future Supply. US Geological Survey, p. 797. Available at: <https://doi.org/10.3133/pp1802>.
- Roskill (2015) Natural and Synthetic Graphite: Global industry, Markets and Outlook to 2020. 9th Edition. Available at: <https://roskill.com/market-reports/>.

- Roskill (2019a) 'China-US trade war reaches graphite industry'. Available at: <https://roskill.com/news/graphite-china-us-trade-war-reaches-graphite-industry/>.
- Roskill (2019b) 'Flake prices falter as African exports meet new demand — for now.pdf'. Available at: <https://roskill.com/news/graphite-flake-prices-falter-as-african-exports-meet-new-demand-for-now/>.
- Roskill (2019c) 'Graphite : The race for non-Chinese spherical graphite heats up', pp. 1–5. Available at: <https://roskill.com/news/graphite-the-race-for-non-chinese-spherical-graphite-heats-up/>.
- Roskill (2019d) 'Graphite : Widespread progress for flake graphite projects'. Available at: <https://roskill.com/news/graphite-widespread-progress-for-flake-graphite-projects/>.
- Roskill (2019e) 'Graphite : Widespread progress for flake graphite projects'.
- Roskill (2019f) Lithium-ion Batteries: Outlook to 2028, 3rd Edition.
- S&P Global Market Intelligence (2018) Graphite Commodity profile. Metals and Mining properties. Available at: <https://www.spglobal.com/marketintelligence/en/> (Accessed: 13 December 2018).
- Scogings, A., Chesters, J. and Shaw, B. (2015) 'Rank and file : Assessing graphite projects on credentials', *Industrial Minerals*, (August), pp. 50–55. Available at: [http://www.csaglobal.com/wp-content/uploads/2015/07/Pg-50-55-Graphite-success-08\\_15\\_proof\\_5.pdf](http://www.csaglobal.com/wp-content/uploads/2015/07/Pg-50-55-Graphite-success-08_15_proof_5.pdf).
- SGL Carbon (2019) The SGL business unit. Graphite Materials & Systems. Available at: <https://www.sglcarbon.com/en/company/about-us/company-profile/graphite-materials-systems/> (Accessed: 27 October 2019).
- Sinograf (2019) Natural graphite. Available at: <http://www.sinograf.com/en/414/natural-graphite-2> (Accessed: 27 October 2019).
- Sundqvist Ökvist, L. et al. (2018) Production technologies of critical raw materials from secondary resources. SCRREEN project D.4.2. Available at: <http://screen.eu/results/>.
- Superior Graphite (2019) Superior Graphite website. Available at: <https://superiorgraphite.com/> (Accessed: 3 September 2019).
- Syrah Resources (2019) 'Annual report 2018'. Available at: <http://www.syrahresources.com.au/31-december-2018-annual-report>.
- Talga Resources (2018) Annual Report 2018. doi: 10.1109/wisnet.2018.8311541.
- Talga Resources (2019) 23-5-2019 Announcement: Outstanding PFS results support Vittangi graphite development. Available at: <http://www.talgaresources.com/irm/content/asx-announcements.aspx?RID=8>.
- Tercero, L. et al. (2015) Critical Raw Materials Substitution Profiles, CRM \_Innonet. Available at: [http://publica.fraunhofer.de/eprints/urn\\_nbn\\_de\\_0011-n-4455718.pdf](http://publica.fraunhofer.de/eprints/urn_nbn_de_0011-n-4455718.pdf).
- Tercero, L. et al. (2018) Critical Raw Material substitution profiles. SCRREEN project D5.1., SCRREEN - D5.1. Available at: <http://screen.eu/wp-content/uploads/2018/05/SCRREEN-D5.1-CRM-profiles.pdf>.
- Tercero, L. (2019) Report on the future use of critical raw materials. SCRREEN project D.2.3. Available at: <http://screen.eu/results/>.
- UN Comtrade (2019) International Trade Statistics Database. Available at: <https://comtrade.un.org/> (Accessed: 8 July 2019).
- USGS (2018a) Mineral Commodity Summaries 2018, Mineral Commodity Summaries. U.S Geological Survey. doi: 10.3133/70194932.

- USGS (2018b) 'Minerals Yearbook 2015. Graphite'. US Geological Survey. Available at: <https://www.usgs.gov/centers/nmic/graphite-statistics-and-information>.
- USGS (2019a) Graphite Statistics and Information. Minerals Yearbook 2004 to 2016. Available at: <https://www.usgs.gov/centers/nmic/graphite-statistics-and-information> (Accessed: 3 September 2019).
- USGS (2019b) Mineral Commodity Summaries 2019. U.S Geological Survey. doi: 10.1007/978-3-540-47108-0-4.
- World Bank (2018) Aggregate Governance Indicators 1996-2017, Worldwide Governance Indicators. Available at: <http://info.worldbank.org/governance/WGI/#home> (Accessed: 7 July 2019).
- Yang, J. et al. (2018) Production technologies of critical raw materials from primary resources. SCRREEN project D.4.1. Available at: <http://screen.eu/results/>.

### **16.7.2 Data sources used in the criticality assessment**

- WMD (2019) World Mining Data 2019, Reichl, C.; Schatz, M; Zsak, G. Iron and Ferro Alloy Metals, non Ferrous Metals, Precious Metals, Industrial Minerals, Mineral Fuels. Austrian Federal Ministry of Sustainability and Tourism. [online] Available at: [www.en.bmfwf.gv.at/Energy/WorldMiningData/Seiten/default.aspx](http://www.en.bmfwf.gv.at/Energy/WorldMiningData/Seiten/default.aspx)
- Eurostat (2019b) *Easy Comext database*. Available at: <http://epp.eurostat.ec.europa.eu/newxtweb/>.
- Draft natural graphite MSA (2019) Results of the natural graphite MSA Study. Internal document – not published. Reference date: 23 December 2019.
- BRGM (2016) 'Le graphite naturel (C) – éléments de criticité'. Bureau de Recherches Géologiques et Minières, p. 401. Available at: <http://www.mineralinfo.fr/page/fiches-criticite>.

### **16.8 Acknowledgements**

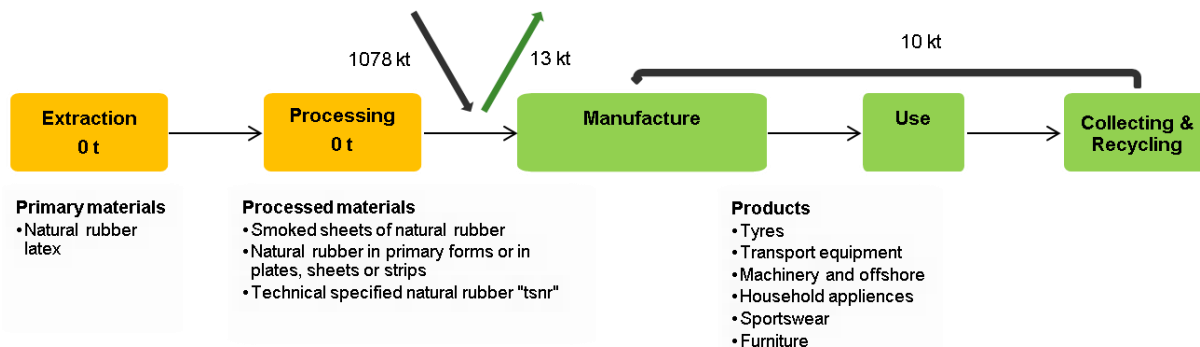
---

This factsheet was prepared by the JRC. The authors would like to thank the Ad Hoc Working Group on Critical Raw Materials, as well as experts participating in SCRREEN workshops for their contribution and feedback.



# 17 NATURAL RUBBER

## 17.1 Overview

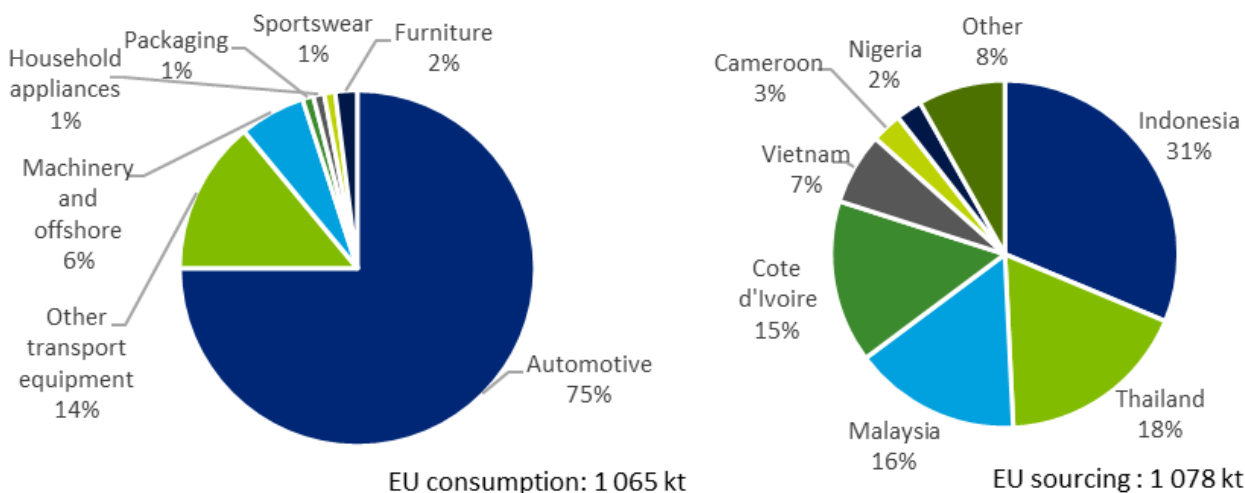


**Figure 205: Simplified value chain for natural rubber, data on trade represents average between 2012 and 2016, extraction and processing occur only outside the EU.**

Natural rubber is primarily harvested from the rubber tree *Hevea brasiliensis*. Although native to the Amazon region, over 90% of natural rubber is now produced in Southeast Asia. The tyre industry is the largest consumer of natural rubber, accounting for around 72% of the annual demand (in 2017). Use of natural rubber in European value chains is dominated by the tyre industry, whereas in Asia the General Rubber Goods (GRG) applications in high-tech industries play an important role. There are many uncertainties in natural rubber production for both end-user and producer given the biotic nature of the raw material.

The trade assessment is based on four products groups, with CN codes 40011000 (Natural Rubber or Latex, whether or not pre-vulcanized, considering 60% of Natural rubber content), 40012100 (smoked sheets of natural rubber), 40012200 (technically specified natural rubber (TSNR)), 40012900 (natural rubber in primary forms or in plates). Quantities are expressed in natural rubber content in all the assessment.

In 2018, the global production of natural rubber achieved 13,869 kt (IRSG, 2019). Natural rubber production is dominated by Thailand and Indonesia, which accounted for more than 62% of global production in 2018.



**Figure 206 : End uses and EU sourcing of Natural Rubber, average 2012 to 2016 (Eurostat 2019b).**

The price of rubber has hovered between US\$ 0.49 and 6.56 per kilogram over the last 19 years (2000-2019). The EU consumption (Figure 206) of natural rubber was around 1,065 kt (75% in automotive and 14% in other transport equipment). It was mainly sourced through imports, from Indonesia, Thailand and Malaysia (average 2012-2016, Figure 206). The EU consumption continued to increase in 2017 and 2018, achieving a value of 1,216 kt in 2018. Also, in 2018 the global share of the imports from Cote D'Ivoire increased of 20% of the total. There is no natural rubber production in the EU, neither any processing. The traded natural rubber materials are used directly in manufacturing.

The EU consumes natural rubber mainly in tyres. For this application it is not possible to substitute it with synthetic rubber.

The world production of natural rubber was about 13,869 kt in 2018 with 37% of production in Thailand and 25% in Indonesia. The main production (99%) of natural rubber originates from the rubber trees, grown mainly by smallholders in South East Asia (85%) (ETRMA, 2019a). Natural rubber is mainly harvested from the rubber tree *Hevea brasiliensis* in the form of latex. After harvesting, the latex can be refined into different rubber products and grades.

Natural Rubber is mostly used in a mix with synthetic rubber. Therefore, the recycling of rubber products does not permit a recycling or reuse of natural rubber *per se*, but of a mix of natural and synthetic rubbers. Today, with the available technology, there is only limited scope for recycling from product-to-new-product (ETRMA, 2019a). Less than 1% of natural rubber is functionally recycled in the EU.

Natural rubber is produced mainly by smallholders of natural rubber plantations. It is estimated that up to 20 million families are fully or partially dependent on rubber cultivation for their basic source of livelihood (ETRMA, 2019a).

Natural rubber supply may be highly affected by *Microcyclus ulei* (South American leaf blight). *Microcyclus ulei* is a fungal disease able to destroy young rubber trees. The impact of such disease was already demonstrated in South and Central America, where the disease destroyed the attempts made to increase the production of natural rubber in those regions.

Major increase in supply of the raw material cannot be adjusted within a few years, due to the long maturity period of rubber trees (5-7 years). This means that new natural rubber supply potential for a forecast period of 10 years has largely already been decided.

## **17.2 Market analysis, trade and prices**

---

### **17.2.1 Global market analysis and outlook**

The forecast of the worldwide supply of natural rubber is mainly determined by the following factors: demand for automotive and other transport equipment, oil prices, balance between markets for tyres and General Rubber Goods (GRG), and the development of synthetic rubber manufacturing technology. The International Rubber Study Group (IRSG) (IRSG 2018) estimates that global natural rubber (NR) production is expected to grow at an average of 2.1% per year during the period 2019-2027. Natural rubber consumption in the tyre sector is expected to grow by an average of 1.8% per year in between 2019 and beyond. While the global natural rubber demand by GRG is expected to increase by 4.4% in 2019, followed by deceleration in the subsequent years until 2027.

**Table 92: Qualitative forecast of supply and demand of natural rubber**

Materials	Criticality of the material in 2020		Demand forecast			Supply forecast		
	Yes	No	5 years	10 years	20 years	5 years	10 years	20 years
Natural rubber	X		+	+	N.A	+	+	N.A

N.A. information not available

These estimates show that supply and demand balance should be achieved in the next 7 years (estimates done until 2027). However, major phenomenon's such as plantation disease and economic growth in major developing economies (e.g. China and India) may not be accompanied by sufficient natural rubber production in an agricultural sector where plantations take 5-7 years to become productive (ETRMA, 2019b).

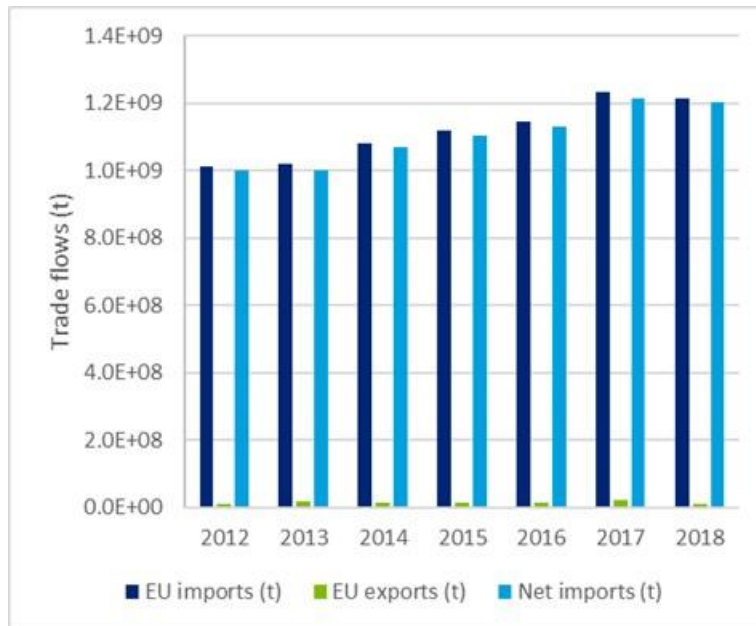
Since the main application of natural rubber is tyres, the demand for natural rubber is also controlled by the developments in the vehicle market. Although, China's vehicle market growth is slowing down 31 million new light vehicle registrations are expected for 2020, which lead to a 48.1% growth of new registrations since 2013 (Accenture 2013) and a car parc approaching 250 million in 2019 (Statistica 2019) nearing the one of the EU, with 268 million passenger vehicles in 2017 (ACEA, 2019). World light vehicle (passenger cars) new registrations reached 78.7 million in 2018 of which Europe only represent 19% and China a calculated 37.5% (ETRMA, 2019b). Over the last decade, the Chinese tyre market has therefore placed increased pressure onto the natural rubber market and will continuously increase its demand for both new vehicles and replacement of used tyres (ETRMA, 2019b).

It is important to highlight that the supply of natural rubber is also governed by the International Rubber Consortium Ltd. ([www.irco.biz](http://www.irco.biz)). This consortium was created in 2004 having the main producing countries (Indonesia, Malaysia and Thailand) as sole members. It has two main objectives: i) achieve long term price trend stabilised and remunerative to the farmers and, ii) maintain a supply-demand balance to ensure adequate supply of natural rubber in the market at fair prices.

## 17.2.2EU trade

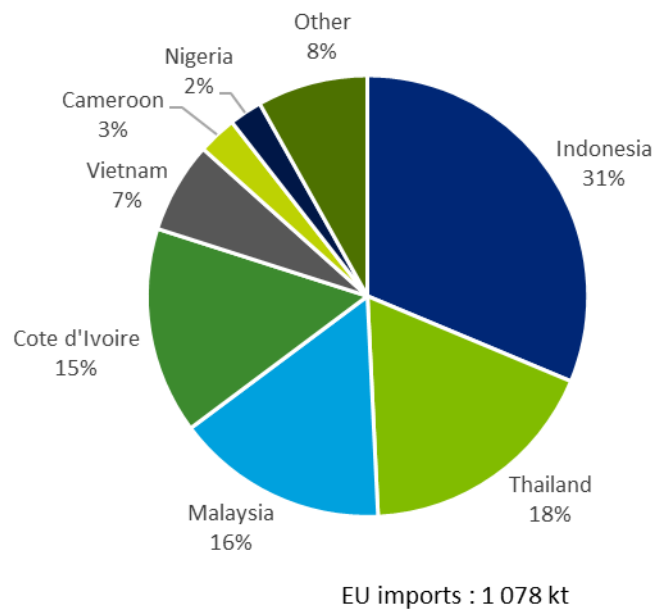
The EU is a net importer of natural rubber. The EU imports averaged 1,078 kt per year of natural rubber, from 2012 to 2016. Exports observed during this period correspond to re-exports of natural rubber about 13 kt per year (average 2012 to 2016). This means that materials can originate from a country that is merely trading instead of producing the particular material. The latest available data suggests that imports continued to grow achieving 1,216 kt in 2018, see Figure 207<sup>175</sup>.

<sup>175</sup> The criticality assessment was done for the average years 2012 to 2016.



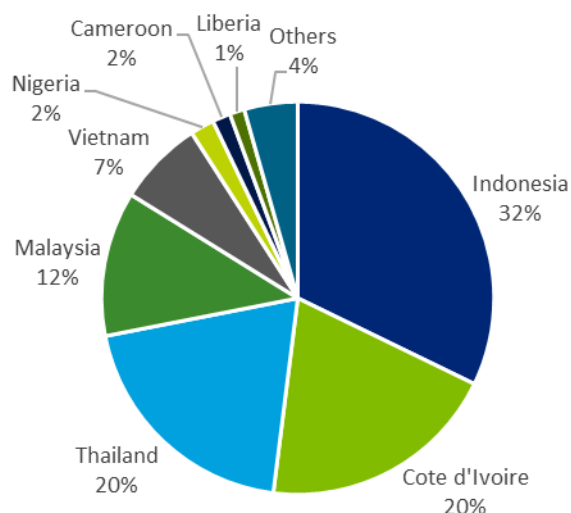
**Figure 207: EU trade flows for natural rubber (Eurostat 2019b)<sup>176</sup>**

The main suppliers for the EU are Indonesia (31%), Thailand (18%), Malaysia (16%), Côte d’Ivoire (15%) (average 2012-2016, Figure 208). In 2018 the share of imports from Cote d’Ivoire increased to 20% of the total (Figure 209), diversifying the of supply risk otherwise heavily concentrated on Indonesia, Thailand and Malaysia.



**Figure 208: EU imports of natural rubber, average 2012-2016 (Eurostat 2019b)**

<sup>176</sup> The 2017 and 2018 data were not used in the criticality assessment.



**Figure 209: EU imports of natural rubber, 2018 situation (Eurostat 2019b)<sup>177</sup>**

Around 1.2% of the imports are exported outside the EU as re-exports. There is no domestic production in the EU of natural rubber.

### 17.2.3 Prices and price volatility

Natural rubber is a commodity traded at three main trading platforms: SICOM/SGX (Singapore Commodity Exchange/Singapore Exchange), TOCOM (Tokyo Commodity Exchange) and SHFE (Shanghai Futures Exchange).

The price of rubber has hovered between US\$ 0.49 and 6.56 per kilogram over the last 19 years (2000-2019)., see Figure 210. The price volatility is mainly influenced by shifting demand from industry and shifting supply as a result of influences from the environment (e.g. weather conditions).



**Figure 210: Prices for natural rubber, 2004-2019 (Data from Indexmundi, 2019)**

<sup>177</sup> This data was not used in the criticality assessment

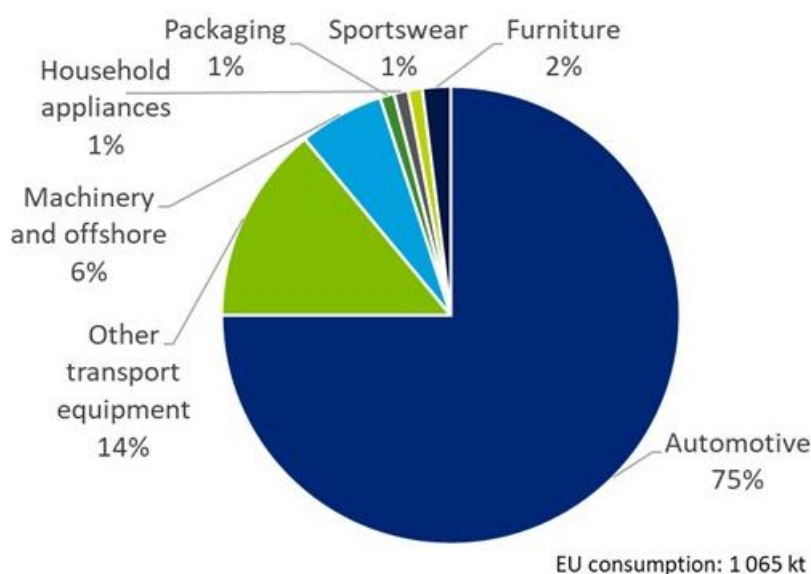
## 17.3 EU demand

### 17.3.1 EU demand and consumption

The average annual consumption of natural rubber in the EU was ,1,065 kt over the 2012-2016 period. The annual consumption is constantly increasing and achieved 1,216 kt in 2018.

### 17.3.2 Uses and end-uses of natural rubber in the EU

Figure 211 presents the main uses of natural rubber in the EU.



**Figure 211: EU end uses of Natural rubber. Calculated taking into account (ETRMA, 2016)**

The tyre industry uses up to 72% of natural rubber consumed in the EU, plus 3% in other automotive parts. A common car tyre contains 15% natural rubber by weight and a truck tyre will contain on average 30%. The remaining content of tyres consists, among others, of synthetic rubber, carbon black and silica as tyre fillers, steel cord and wires to provide strength, and other chemicals such as oils and zinc oxide.

Other General Rubber Goods (GRG) uses can be divided into three categories: industrial products, such as moulded and extruded products, belting, hose and tube. These products are generally used in machinery and household goods. Another class of applications are final consumer products, such as footwear, toys, sports and leisure goods; and latex products, such as dipped goods, thread, adhesives, carpet underlay, gloves and condoms.

Relevant industry sectors are described using the NACE sector codes (Eurostat 2019a), in Table 93.

**Table 93: Natural rubber applications, 2-digit and associated 4-digit NACE sectors, and value added per sector (Eurostat 2019c)**

<b>Applications</b>	<b>2-digit NACE sector</b>	<b>4-digit NACE sector</b>	<b>Value added of sector (millions €)</b>
Packaging	C22 - Manufacture of rubber and plastic products	22.11 Manufacture of rubber tyres and tubes; rereading and rebuilding of rubber tyres	75 980
Household appliances	C27 - Manufacture of electrical equipment	27.51 Manufacture of electric domestic appliances	80 745
Machinery and offshore	C28 - Manufacture of machinery and equipment n.e.c.	28.13 Manufacture of other pumps and compressors	182 589
Automotive	C29 - Manufacture of motor vehicles, trailers and semi-trailers	29.10 Manufacture of motor vehicles	160 603
Other transport equipment	C30 - Manufacture of other transport equipment	30.12 Building of pleasure and sporting boats	44 304
Furniture	C31 - Manufacture of furniture	31.02 Manufacture of kitchen furniture	26 171
Sportswear	C32 - Other manufacturing	32.30 Manufacture of sports goods	39 160

### 17.3.3 Substitution

Today 99% of the natural rubber consumed in the world comes from areas where *Hevea brasiliensis* trees. These trees can be cultivated mainly in tropical forests, close to the equator. Therefore, there is a particular EU interest in developing additional natural sources that can grow in other geographical regions and notably in Europe.

Research is focused on developing natural rubber from alternative plant sources of latex, that can grow in other geographical regions and notably in Europe. More specifically, scientists are looking at using *Parthenium argentatum* (guayule) and *Taraxacum koksaghyz* (Russian dandelion) as alternative rubber and latex sources. These are the only other species known to produce large amounts of rubber with high molecular weight. The EU-PEARLS (Production and Exploitation of Alternative Rubber and Latex Sources) project was a European research project that investigated the possibility of using the natural rubber from these two alternatives. The project consortium proved that the natural rubber extracted from these trees could substitute the one extracted from *Hevea brasiliensis*. However, there are still significant challenges to reach the industrialisation stage of these alternative natural rubber sources, any significant market change will be absent (at least) in the very short term (ETRMA, 2019a). This is particularly due to the absence of production capacity in the EU to convert the plant extract into raw rubber, which today is imported from third countries.

The choice of elastomer is at the heart of any substitution option. The elastomer presents certain mechanical properties such as wear and tear resistance, stiffness, heat resistance and hysteresis. The most important synthetic rubbers are polybutadiene, butyl and halo-butyl, polyisoprene and styrene butadiene. Given the requirements of the substitution of natural rubber with synthetic rubber is limited to 2 percentage points in tyres. The substitution rate is higher for General Rubber Goods, depending on the specific application.

In packaging, household appliances, sportswear and furniture, plastics in general can be a substitute (European Commission 2017).

Synthetic rubber has been long used as an alternative or supplement to natural rubber. An example is styrene butadiene; however, these synthetic rubbers cannot match price and performance of natural rubber (van Beilen and Poirier 2007) in tyre applications. For example, synthetic rubber does not have an equally high molecular mass which defines the quality of the rubber and does not contain the non-rubber components which are found in the latex produced by rubber plants (Gronover, Wahler, and Prufer 2011). Natural rubber also exhibits greater resistance to tearing at high temperatures and builds up less heat from flexing. For this reason, truck tyres require a higher percentage of natural rubber than those for passenger cars.

## 17.4 Supply

---

### 17.4.1 EU supply chain

In 2018, the production of natural rubber containing goods within the EU amounted to 2 800 kt of General Rubber Goods (GRG) and around 5 100 kt of tyres. The rubber processing sector in the EU employed around 368 980 people directly in 2018 (ETRMA, 2019).

The EU is fully relying on imports (import reliance of 100%), where 1.2% of its imports are exported outside the EU as re-exports. There is no, noteworthy, EU domestic production of natural rubber. EU natural rubber production is still at an experimental development stage.

### 17.4.2 Supply from primary materials

#### 17.4.2.1 Resources and reserves of natural rubber

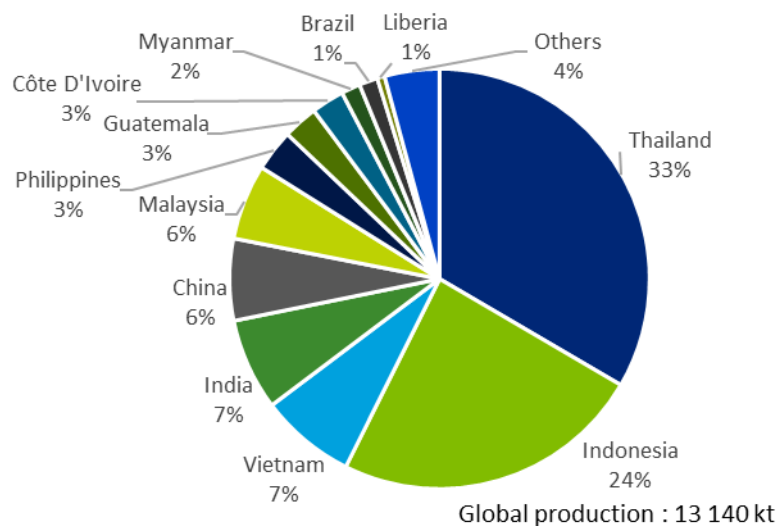
Natural rubber is a biotic material which is harvested from rubber trees (*Hevea brasiliensis*), mainly growing in tropical forests close to the equator. *Hevea brasiliensis* is a native species of the Amazon region, but has been introduced in several other regions for rubber production. At the moment, south-east Asian countries, mainly Indonesia and Thailand, are the biggest global producers and at the same time biggest suppliers of natural rubber to the EU.

**Global resources and reserves:** The overall acreage of national rubber plantations is estimated around 12 million hectares (FAO, 2019). The average yield between 2012 and 2016 was 1196 kg/ha (FAO, 2019). Rubber plantations are facing competition of other crops (palm oil, grains etc.) that together with the geographical constraints limits the flexibility to expand the total acreage of natural rubber plantations.

#### 17.4.2.2 World and EU production

Global production has increased rapidly over the past 50 years. This increase has been mostly due to increased production in Thailand and Indonesia. The global production of natural rubber between 2012 and 2016 was 13 140 kt on average, dominated by Thailand and Indonesia, which account for more than 57% of global production. In 2016 the total production of Natural Rubber reached 13 497 kt. Figure 212 shows the global production. There is no production of natural rubber in the EU.





**Figure 212: Global production of natural rubber in tonnes and percentage. Average for the years 2012-2016 (FAO, 2019).**

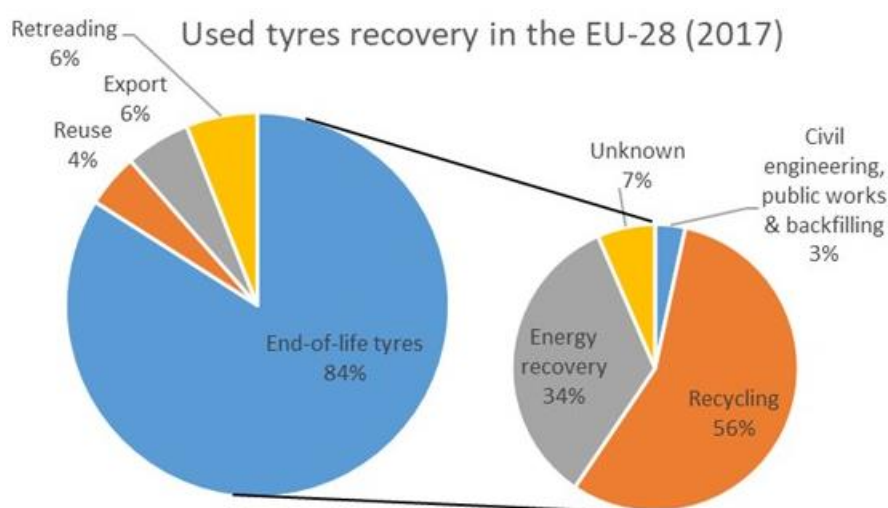
### 17.4.3 Supply from secondary materials/recycling

#### 17.4.3.1 Post-consumer recycling (old scrap)

In terms of recycling, biotics are to be dealt differently than the majority of the abiotic materials. For the majority of the cases, the recovered biotic the equivalent to "old scrap" simply can't be re-used in the same application or with the same properties as the original raw material due to contamination issues. Natural rubber is mostly used in a mix with synthetic rubber to obtain the desired hard rubber product performances. With the available technology it is not possible to recycle rubber products and extract natural rubber from these mixtures, therefore recycling is always a mix of natural and synthetic rubbers.

Primary natural rubber is currently only for an estimated 1% being replaced by secondary natural rubber (see Table 94 for underlying data).

The next figure shows the EU situation for used tyres. Tyres are the main application of natural rubber in the EU, as demonstrated in the previous section.



**Figure 213: Used tyres recovery in the EU-28 in 2017. (ETRMA, 2017)**

Since 2006, all EU member states are obliged to arrange a collection and recycling of end-of-life tyres. Collected data confirm a material recovery (recycling) rate of 56% and an energy recovery rate of 34%. An outstanding 7% is not fully accounted for.

Despite the high recovery rate reached for end-of-life tyres in EU, for the criticality assessment of natural rubber, it is important to highlight that tyre recycling features an open-loop recycling, meaning that end-of-life tyres (ELT)-derived rubber granulates are mainly downcycled in other applications than tyres as current tyre devulcanization technologies are not selective enough to get high quality devulcanization, which is requested to meet stringent technical performances imposed by EU regulation (tyre wet grip, rolling resistance, noise) as well as safety performances. Therefore, the current recycling of ELTs & End of-Life GRG products does not lead to a reduction of the natural rubber supply risk.

With regard to recycling, near 1.5 million tonnes (1,469 kt) of ELTs are annually processed for granulation and are used in a multitude of applications - such as synthetic turf, children playgrounds, sport surfaces, moulded objects, asphalt rubber, acoustic & insulation applications - substituting other raw materials than natural rubber (for example, virgin EPDM in synthetic turf, polyurethane in moulded objects).

For GRG the recycling of natural rubber products mainly occurs in a limited way, mainly due to the heterogeneity of elastomers used and the multitude of SMEs in the GRG sector making economies of scale difficult to get. End-of-life recycling of GRG products is limited either due to contamination issues (e.g. dismantling of End-of-life vehicle seals, tubes etc.) or due to the mere impossibility to recycle/collect the application (condoms, clinical gloves, etc.) (European Commission 2017).

**Table 94: Material flows relevant to the EOL-RIR of natural rubber 2016 data**

MSA Flow	Value (t)
B.1.1 Production of primary material as main product in EU sent to processing in EU	0.00
B.1.2 Production of primary material as by product in EU sent to processing in EU	0.00
C.1.3 Imports to EU of primary material	45 754
C.1.4 Imports to EU of secondary material	0.00
D.1.3 Imports to EU of processed material	1 098 797
E.1.6 Products at end of life in EU collected for treatment	N.A
F.1.1 Exports from EU of manufactured products at end-of-life	N.A
F.1.2 Imports to EU of manufactured products at end-of-life	N.A
G.1.1 Production of secondary material from post consumer functional recycling in EU sent to processing in EU	0.00
G.1.2 Production of secondary material from post consumer functional recycling in EU sent to manufacture in EU	10 004

N.A. not available at the time of producing this factsheet

#### 17.4.4 Processing of natural rubber

Natural rubber is mainly harvested from the rubber tree *Hevea brasiliensis* in the form of latex, which is a white emulsion. While latex can also be sourced from other tree species, its applicability is not as straightforward as that extracted from *Hevea brasiliensis*.

The rubber tree is a perennial crop that is harvested throughout the year. Natural rubber is extracted by making a cut in the bark of the rubber tree, commonly designated as tapping. The rubber can start to be harvested when the tree reaches at least 45 cm in circumference, which corresponds to a tree age of about six years. The maximum yield is

reached around the fifth to the tenth year of tapping. A rubber tree is productive for 20 to 40 years, where the length of the productive period is largely determined by the tapping intensity. Afterwards replanting is required and the old tree can be harvested to provide wood for furniture.

The long maturity period of rubber trees (5-7 years) means that the natural rubber supply potential for the forecast period of 10 years has largely been decided, and major increases in supply cannot be adjusted within a few years.

After tapping, the latex can be processed into different rubber products and grades. Traditionally, it is coagulated using formic or acetic acid, and then pressed between pairs of rollers to form sheets or 'crepes'. In the final process, the natural rubber is washed and dried. Dried natural rubber is usually vulcanised, a chemical process that involves heating and the addition of sulphur or other cross-linking additives. This process improves the elasticity and durability of the untreated natural rubber. Vulcanised rubber is then further processed into different rubber products.

## **17.5 Other considerations**

---

### **17.5.1 Environmental and health and safety issues**

Natural rubber supply may be highly affected by *Microcyclus ulei* (South American leaf blight). *Microcyclus ulei* is a fungal disease able to destroy young rubber trees. The impact of such disease was already demonstrated in South and Central America, where the disease destroyed the attempts made to increase the production of natural rubber in those regions. Until the moment no records of such disease have been reported in Asia, in the countries where the majority of natural rubber is produced. However, several authors indicate that the low genetic variety of the Asian rubber plantations (the majority of the production comes from Brazilian tree clones, susceptible to the disease) makes them highly sensitive to this disease. If the disease would spread to Asia, the impacts on natural rubber production could be devastating (Invasive Species Compendium 2015).

Another example of a biological threat affecting supply of natural rubber is the case of the *Neofusicoccum ribis*, which causes leaf fall in natural rubber plantations in Indonesia. The expectation is that natural rubber output in Indonesia will drop by 15% in 2019 (ETRMA, 2019b).

The distribution of rubber plantations cross Southeast Asia coincides with four biodiversity hotspots (Sundaland, Indo-Burma, Wallace and the Philippines) supporting large number of endemic and highly threatened species. Meeting global rubber demand while minimizing biodiversity and ecosystem service losses will be very challenging in the future (Warren-Thomas, Dolman, and Edwards 2015).

### **17.5.2 Socio-economic issues**

Being a biotic material, sustainable sourcing of natural rubber focuses on the risk of biodiversity loss, on promoting good agricultural practices and on mitigating land ownership conflicts.

Natural rubber is mainly produced by smallholders in South East Asia. It is estimated that up to 20 million families are fully or partially dependent on rubber cultivation for their basic source of livelihood (ETRMA, 2019a). At the same time, rubber plantations can threaten the livelihood of indigenous communities which in some cases are subject to physical displacement and resettlement as in the case of the Orang Rimba community in the provinces of Jambi, Riau and South Sumatra, in Indonesia (EJ Atlas 2019).

As for other materials, due diligence systems (see Table 95) are in place and they require ensuring decent working conditions and the respect of human rights along the value chain (SNR, CCCMC, 2017).

**Table 95: Sustainable sourcing initiatives on Natural Rubber (SNR, CCCMC, 2017)**

<b>Initiative full Name</b>	<b>Lead Stakeholder</b>	<b>Geographical Focus</b>	<b>Short description</b>
Sustainable Natural Rubber Initiative (SNR-i)	Multi-stakeholders	Global	The objectives of the SNR-i are to secure a global sustainable natural rubber economy that delivers benefits across the whole of the natural rubber value chain.
CCCMC and CSR Sustainable Natural Rubber Collaborative Platform	Business associations	Global	The Platform was launched by the China Chamber of Commerce of Metals, Minerals and Chemicals Importers and Exporters (CCCMC) and CSR Europe. It engages in practical actions to improve the level of sustainability in the natural rubber supply chain.
Tire Industry Project (TIP)	Industry	Global	Tyre Industry Project (TIP) serves as a global, voluntary, CEO-led initiative, undertaken by 11 leading tyre companies—representing approximately 65 percent of the world’s tyre manufacturing capacity. Its aim is to proactively identify and address the potential human health and environmental impacts associated with the life cycle impacts of tyres to proactively contribute to a more sustainable future.

## **17.6 Comparison with previous EU assessments**

Natural rubber was first assessed in 2014. The result of the 2014 assessment was an Economic Importance that was clearly above the criticality threshold (around 7.7); however, the supply risk score was below the criticality score with a numerical value of around 0.9. See Table 96.

The increase of supply risk from 0.9 in 2014 to 1.0 in 2017 and 2020 is mainly due to changes in the revised methodology regarding the calculation of the supply risk, recycling and substitution options. The calculation of the SR for natural rubber in the 2017 and 2020 assessments considered an import dependency of 100%, which was not considered in 2014. The 2017 and 2020 assessments reporting a final SR score of 1.0 (SR=0.9 in 2014) are also influenced by the lack of readily available substitutes for the identified end-use applications and the low EOL-RIR (1%). The differences in the economic importance from 2017 and 2020 are due to an update of the use shares that now reflects better the EU consumption of natural rubber, with an increase in the applications in other transport sectors beside “automotive”.

**Table 96: Economic importance and supply risk results for natural rubber in the assessments of 2011, 2014, 2017, 2020 ((European Commission 2011)(European Commission 2014)(European Commission 2017))**

Assessment	2011		2014		2017		2020	
Indicator	EI	SR	EI	SR	EI	SR	EI	SR
Natural rubber	N/A	N/A	7.7	0.9	5.4	1.0	7.10	1.00

## 17.7 Data sources

### 17.7.1 Data sources used in the factsheet

(ETRMA), European Tyre & Rubber Manufacturers Association (2016). THE RUBBER GOODS FACTS & FIGURES.

(ETRMA), European Tyre & Rubber Manufacturers Association (2017). ELT Management in Europe - Volumes Situation 2016.

(ETRMA), European Tyre & Rubber Manufacturers Association (2019a). A Sustainable Natural Rubber Supply Chain 2019 draft 2.

(ETRMA), European Tyre & Rubber Manufacturers Association (2019b). Personal communication from expert Morten Petersen.

(ETRMA), European Tyre & Rubber Manufacturers Association (2019c). The ETRMA Statistics Report. 48. <https://doi.org/10.1021/jp980049f>

Accenture. (2013). China ' s Automotive Market. In Current. Retrieved from <https://www.statista.com/statistics/285306/number-of-car-owners-in-china/>

EJ Atlas. (2019). Plantation companies grab Orang Rimba indigenous land on Sumatra, Indonesia | EJAtlas. Retrieved November 5, 2019, from <https://ejatlas.org/conflict/palm-oil-companies-grab-orang-rimba-land>

European Automobile Manufactures, A. (2019). EU Key Figures. Retrieved from <https://www.acea.be/statistics/tag/category/key-figures>

European Commission. (2011). Critical raw materials. Retrieved July 8, 2019, from [https://ec.europa.eu/growth/sectors/raw-materials/specific-interest/critical\\_en](https://ec.europa.eu/growth/sectors/raw-materials/specific-interest/critical_en)

European Commission. (2014). Report on critical raw materials for the EU - Critical raw materials profiles. Retrieved from <https://ec.europa.eu/docsroom/documents/11911/attachments/1/translations/en/re nditions/pdf>

European Commission. (2017). Study on the review of the list of critical raw materials. Non-critical raw materials factsheets. <https://doi.org/10.2873/876644>

Eurostat. (2019a). Annual detailed enterprise statistics for industry (NACE Rev. 2, B-E). Retrieved July 7, 2019, from [https://ec.europa.eu/eurostat/en/web/products-datasets/-/SBS\\_NA\\_IND\\_R2](https://ec.europa.eu/eurostat/en/web/products-datasets/-/SBS_NA_IND_R2)

Eurostat. (2019b). Easy Comext database. Retrieved from <http://epp.eurostat.ec.europa.eu/newxtweb/>

Eurostat. (2019c). Statistics on the production of manufactured goods (PRODCOM NACE Rev.2). Retrieved July 14, 2019, from Prodcom - Statistics by Product website: <https://ec.europa.eu/eurostat/web/prodcom>

Food and Agriculture Organization of the United Nations, F. (2019). FAOSTAT. Retrieved from <http://www.fao.org/statistics/en/>

- Gronover, C. S., Wahler, D., & Prufer, D. (2011). Natural Rubber Biosynthesis and Physico-Chemical Studies on Plant Derived Latex. *Biotechnology of Biopolymers*, (June 2011). <https://doi.org/10.5772/17144>
- Indexmundi. (2019). Rubber Monthly Price - Euro per Kilogram. Retrieved from <https://www.indexmundi.com/commodities/?commodity=rubber&months=240&currency=eur>
- International Rubber Study Group IRSG. (2019). Rubber Statistical Bulletin.
- Invasive Species Compendium, I. (2015). Information on *Microcyclus ulei* (south American leaf blight of rubber). Retrieved from <http://www.cabi.org/isc/datasheet/33893>
- IRSG, I. R. S. G. (2018). The World Rubber Industry Outlook Review and Prospects to 2027.
- Statista. (2019). Car parc in China from 2007 to 2018 (in millions). Retrieved from <https://www.statista.com/statistics/285306/number-of-car-owners-in-china/>
- Sustainable Natural Rubber & China Chamber of Commerce of Metals, S. C. (2017). Guidance for Sustainable Natural Rubber. 61. Retrieved from <http://www.cccmc.org.cn/docs/2017-11/20171107204714430892.pdf>
- van Beilen, J. B., & Poirier, Y. (2007). Establishment of new crops for the production of natural rubber. *Trends in Biotechnology*, 25(11), 522–529. <https://doi.org/10.1016/J.TIBTECH.2007.08.009>
- Warren-Thomas, E., Dolman, P. M., & Edwards, D. P. (2015, July 1). Increasing Demand for Natural Rubber Necessitates a Robust Sustainability Initiative to Mitigate Impacts on Tropical Biodiversity. *Conservation Letters*, Vol. 8, pp. 230–241. <https://doi.org/10.1111/conl.12170>

### **17.7.2 Data sources used in the criticality assessment**

- ETRMA (2016)a THE RUBBER GOODS INDUSTRY AT A GLANCE Available at: <http://www.etrma.org/uploads/GRG%20Facts%20and%20Figures%20final.pdf>
- FAOstat website (2019) Available at: [www.fao.org/statistics](http://www.fao.org/statistics)
- Eurostat Comext (2019). International trade in goods database (COMEXT) Available at: <http://ec.europa.eu/eurostat/data/database>
- ETRMA factsheet edition 2017.
- European Commission (2017) Study on the review of the list of Critical Raw Materials–Critical raw materials factsheets.
- Plastics Europe, Plastics – the Facts 2017

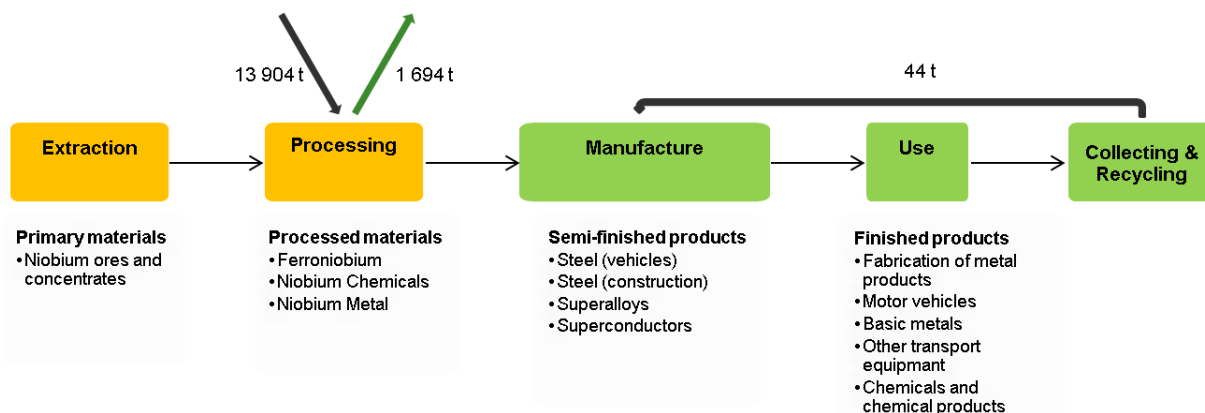
### **17.8 Acknowledgments**

---

This factsheet was prepared by the JRC. The authors would like to thank ETRMA – European Tyre & Rubber Manufacturers’ Association, Morten Petersen, Fazilet Cinaralp and Jean-Pierre Taverne, the EC Ad Hoc Working Group on Critical Raw Materials and all other relevant stakeholders for their contributions to the preparation of this factsheet.

# 18 NIOBIUM

## 18.1 Overview

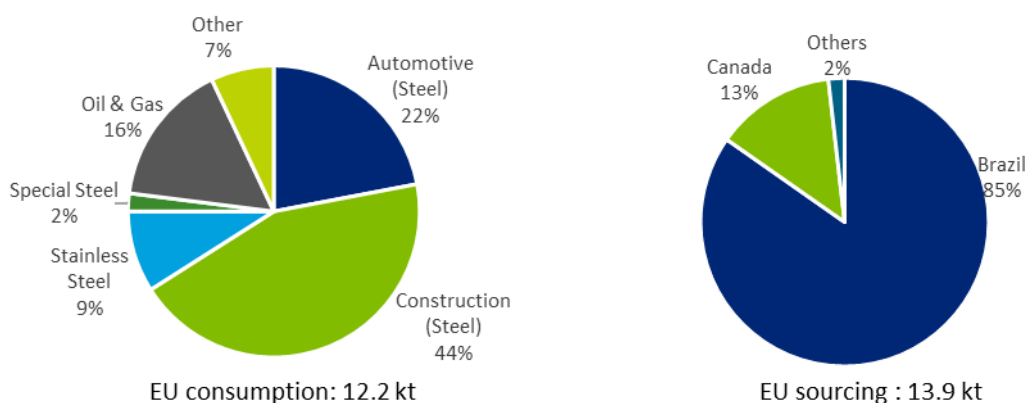


**Figure 214: Simplified value chain for Niobium, data in tonnes of ferroniobium (2012-16 average).**

Niobium (chemical symbol Nb) is grey in colour. It is a relatively hard, paramagnetic, refractory transition metal. It has a density of 8.57 g/cm<sup>3</sup> and a very high melting temperature (2,468°C). Niobium is also highly resistant to chemical attack and behaves as a superconductor at very low temperature. The upper-crustal abundance of niobium is 12 ppm (Rudnick and Gao, 2003), which is higher than some of the other refractory metals, but lower than many of the base metals. Niobium is not found as a free metal in nature, but chiefly occurs in minerals such as columbite and pyrochlore, the latter being the primary ore mineral. Some characteristics and properties are similar to other neighbouring elements on the periodic table. This is the case for tantalum, which is located just below niobium on the periodic table and often appears in the same deposits as niobium (Tercero et al. 2018).

Niobium was on the list of CRMs in 2011, 2014 and 2017.

Trade data for niobium ores and concentrates are not available, for this reason the criticality assessment for niobium is based on the production and trade of ferroniobium CN 72029 300 (Comext; Eurostat, 2019), which is the chief product that enters international trade. Primary extraction of niobium ores and concentrates does not take place in Europe, nor does the production of ferroniobium. Therefore, the EU is entirely reliant on imports of ferroniobium to meet its current demand.



**Figure 215: End uses (CBMM 2019) and EU sourcing of Ferroniobium (average 2012-16) (Comext; Eurostat, 2019).**

Niobium market is small and applications are relatively new. Niobium only became available commercially in the 70's after the Araxa deposit, in Brazil was opened (CBMM, 2019). The global capacity is higher than the current demand. Ferroniobium is not openly traded on any metal exchange. Niobium concentrates (min 50% Nb<sub>2</sub>O<sub>5</sub>) price was 26.30 US\$/kg in average on the period 2014-2018. Niobium pentaoxide (min 99.5%) price was 35.44 US\$/kg in average on the period 2014-2018 (DERA, 2019).

The EU demand of ferroniobium was on average 12.2 kt between 2012 and 2016. EU is 100% import dependent of ferroniobium. Brazil is the main exporting country to the EU accounting with 85% of the EU imports averaged over 2012-2016.

Niobium is mostly consumed in the production of ferroniobium (containing around 65% niobium), which is an important component in high strength low alloy (HSLA) steels used to make car bodies, gas pipelines and ship hulls. It is also used in the manufacture of superconducting magnets, carbide-based cutting tools, high-performance glass coatings and superalloys. Metals such as vanadium, molybdenum, tantalum and titanium may substitute for niobium in the production of HSLA steel and superalloys.

Global Niobium resources are about 83,861 kt, but its production occurs almost exclusively in Brazil, which currently accounts for about 96 % of all global resources. Ten member states are known to have niobium resources.

Global extraction of niobium ores and concentrates takes place in eleven countries; more than 92 % of world production taking place in Brazil, followed by Canada 6 %, Russia, Burundi, Democratic Republic of Congo, Madagascar, Nigeria, Rwanda, and China which account for the remaining 1 % of world's production (WMD, 2019). Average global production of ferroniobium during the 2012-2016 period was almost 42.5 kt per annum (average 2012 to 2016). Ferroniobium production only took place in three countries, Brazil (91.7 %), Canada (8.3 %) and Russia (less than 0.1%). Functional recycling of Niobium is very minor. The EOL-RIR was estimated at 0.3% (BIO Intelligence Service 2015).

No trade restrictions exist for ferroniobium. In its native form niobium is fairly inert and poses few, if any, environmental or human health issues.

## **18.2 Market analysis, trade and prices**

---

### **18.2.1 Global market analysis and outlook**

Niobium only became available commercially in the 70's after the Araxa deposit, in Brazil was opened. The capacity is higher than the demand, plus CBMM has created stockpiled amounts in the EU to prevent shortages (CBMM 2019).

The use of ferroniobium in the production of HSLA steel means that future demand is likely to be driven by the construction and automotive sectors, particularly in rapidly developing countries such as China and India. Ferroniobium production is likely to remain concentrated in Brazil; however, the Araxá niobium deposit, owned by CBMM, has a history of increasing production to meet long-term market demand (Linnen, et al., 2014). Global resources of niobium are estimated as 83,861 kt, therefore significant potential exists for supply to become diversified if advanced projects (Table 97) in other parts of the world e.g. in Australia come to fruition.



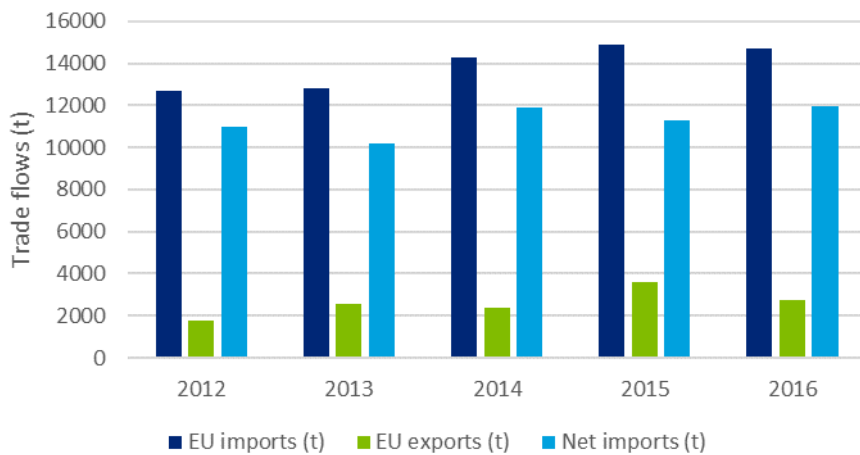
**Table 97: Qualitative forecast of supply and demand of niobium**

Materials	Criticality in 2020		Demand forecast			Supply forecast		
	Yes	No	5 years	10 years	20 years	5 years	10 years	20 years
Niobium	x		+	+	+	+	+	+

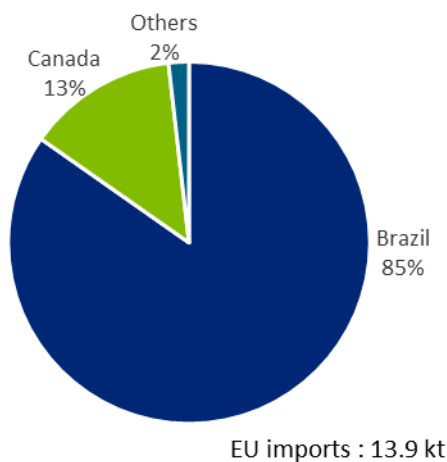
Even if several sources (Tercero et al., 2018) pointed out an increase in the demand of Niobium, in particular in the transportation sector, there are however contradictory estimates showing the decrease of Niobium demand in the EU. SCRREEN deliverable D2.3 refers that if there will be no substitution of different high strength steel alloys with niobium high strength alloys the development of niobium is mostly influenced by a reduction in the use of fossil fuels, in the EU. This will reduce the demand of niobium in gas turbines, gas pipelines and internal combustion engines (Tercero et al., 2018).

**18.2.2EU trade**

Niobium is not traded in the form of ores and concentrates, but rather processed materials such as ferroniobium or niobium metal. According to BIO Intelligence Service (2015), ferroniobium is not produced in the EU. During the period 2012–2016, the EU is entirely reliant on imports for its supply, with an average net import of about 11.3 kt per annum during the period 2012–2016 (Eurostat 2019b).



**Figure 216: EU trade flows for ferroniobium, data from (Eurostat 2019b).**



**Figure 217: EU imports of ferroniobium, 2012-2016 (Eurostat 2019b).**

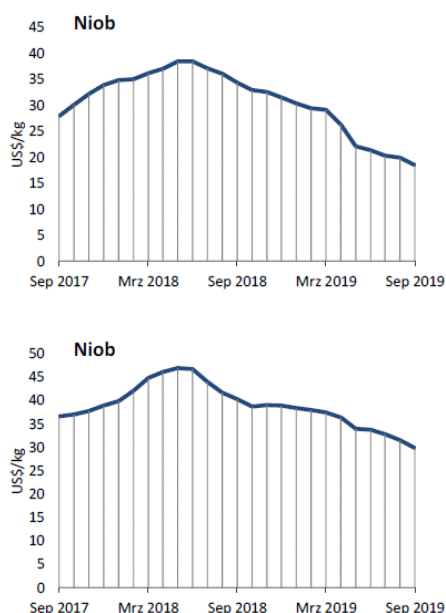
Imports and export to and from the EU have fluctuated slightly during the 2012–2016 period, with a gently increasing trend observed since 2012. Almost 98% of all EU imports of ferroniobium come from only two countries, namely Brazil (84%) and Canada (13%).

Regarding trade agreements in 2019 the EU was the first major partner to strike a trade pact with Mercosur, a bloc comprising Argentina, Brazil Paraguay and Uruguay. In 2016 the EU signed also the EU-Canada Comprehensive Economic and Trade Agreement.

### 18.2.3 Prices and price volatility

Ferroniobium is not openly traded on any metal exchange; contract prices are negotiated between buyer and seller and generally remain confidential (BGS, 2011). DERA reports prices for Niobium concentrates and Niobium pentaoxide (DERA, 2019), see Figure 218:

- Niobium concentrates (min 50% Nb<sub>2</sub>O<sub>5</sub>) price was 26.30 US\$/kg in average on the period 2014-2018. From October 2018 to September 2019 the price average was 26.23 US\$/kg;
- Niobium pentaoxide (min 99.5%) price was 35.44 US\$/kg in average on the period 2014-2018. From October 2018 to September 2019 the price was average was 35.75 US\$/kg.



**Figure 218: Price volatility of: top, Niobium concentrates (min 50% Nb<sub>2</sub>O<sub>5</sub>), botom, Niobium pentaoxide (min 99.5%) (DERA and BGR, 2019).**

This shows a relatively stable period for Niobium prices contrasting the reported drop of more than 40% in 2015-2016 compared to the period 2011-2015 (European Commission 2017).

## 18.3 EU demand

### 18.3.1 EU demand and consumption

Consumption of ferroniobium in the EU was about 12.2 kt per year during the period 2012–2016 (Eurostat, 2019b). None of this was produced within the EU. Therefore, the estimated import reliance is 100%.

### 18.3.2 Uses and end-uses of niobium in the EU

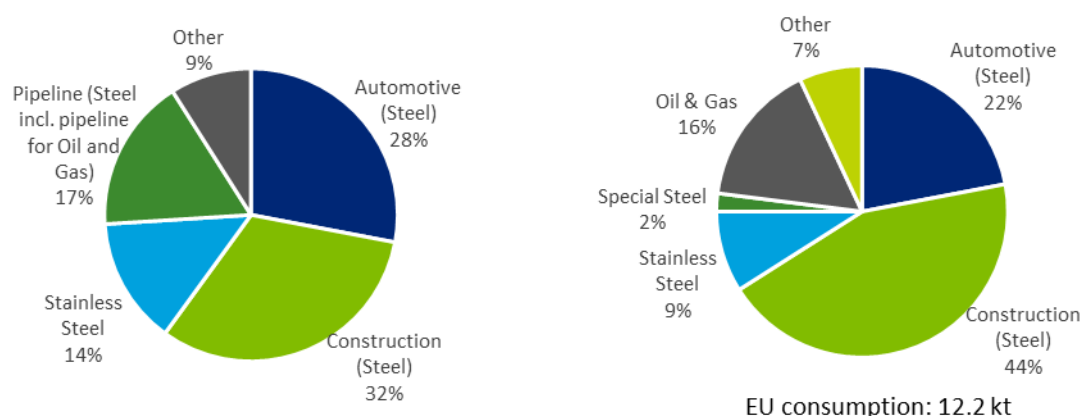
Global and EU end-uses and of niobium are shown in Figure 219 and relevant industry sectors are described using the NACE sector codes in Table 98.

Globally about 90% of niobium (in the form of ferroniobium, in 2017) is used in the production of HSLA steels. In the EU this amount accounts for 93% of the applications. Niobium is an important additive in steel for two reasons: (1) it increases strength by refining the microstructure and by forming nano-particle; and (2) the strength increases it gives allow weight savings in the final product. According to CBMM (CBMM, 2019) in the EU about 22% of niobium is used in the production of automotive vehicles, 18% used in the production of super alloys for gas and oil pipelines and turbines and 24% is used in steel for construction. However, it is not known how much of this niobium is used in high strength steel and which part of the niobium is used in super alloys in the exhaust systems.

Other uses include Niobium-bearing alloys and chemicals. These alloys may contain significant quantities of niobium and are typically used in high-performance, or specialised applications where traits such as corrosion resistance and high-strength at high operating temperatures are sought. These alloys are also used in the nuclear industry (e.g. reactor parts) and space industry. Other alloys of niobium include niobium-titanium and niobium-tin alloys, which are used to manufacture the superconducting magnets found in MRI (Magnetic Resonance Imaging) scanners (BGS, 2011).

Niobium-based chemicals have unique optical, piezoelectric (i.e. the ability to generate an electric charge in response to mechanical stress) and pyroelectric (i.e. the ability to generate an electric charge in response to heating or cooling) properties that are sought after in several high-technology applications. For example, high-purity niobium oxide is used in the production of high-refractive index glass used in the manufacture of camera lenses. Compounds such as lithium niobate are used in the production of capacitors and surface acoustic wave filters, which are used in the manufacture of mobile phones and other touch screen devices. Niobium nitride is also used in the production of superconducting magnets found inside MRI scanners (T.I.C., 2019).

Another important use of niobium is in the production of niobium carbides. These are extremely-hard, ceramic substances which are produced by sintering niobium powder with carbon at high-temperature. They are resistant to wear and high-temperature and are therefore used to produce hard cutting tools (e.g. industrial high-speed cutting tools) and refractory coatings that are used in nuclear reactors and industrial furnaces (BGS, 2011).



**Figure 219: Global end uses in 2017 (left, (CBMM, 208)) and EU end uses (right, (CBMM, 2019)) of niobium, averaged over 2012-2016.**

Producers are still researching new applications for this metal. Future uses include also the application of niobium in battery applications and a new application of niobium in aluminium alloys as a grain refiner (here Al-TiB alloys will be replaced).

The calculation of economic importance is based on the use of the NACE 2-digit codes and the value added at factor cost for the identified sectors (Table 98).

**Table 98: Niobium applications, 2-digit NACE sectors, associated 4-digit NACE sectors, and value added per sector (Data from (Eurostat, 2019a)).**

<b>Applications</b>	<b>2-digit NACE sector</b>	<b>4-digit NACE sector</b>	<b>Value added of sector (millions €)</b>
Automotive (Steel)	C29 - Manufacture of motor vehicles, trailers and semi-trailers	C2910 Manufacture of motor vehicles	160 603
Construction (Steel)	C25 - Manufacture of fabricated metal products, except machinery and equipment	C2511 Manufacture of metal structures and parts of structures	148 351
Oil & Gas	C24 - Manufacture of basic metals	C2420 Manufacture of tubes, pipes, hollow profiles and related fittings, of steel.	55 426
Stainless steel	C24 - Manufacture of basic metals	C2420 Manufacture of tubes, pipes, hollow profiles and related fittings, of steel.	55 426
Special steel	C30 - Manufacture of other transport equipment	C3030 Manufacture of air and spacecraft and related machinery	44 304
Superconductors <sup>178</sup>			

### 18.3.3 Substitution

The main use of niobium is in steel alloys because niobium enhances the steels' mechanical strength, toughness, high temperature strength, and corrosion resistance. These characteristics make niobium an important material in the production of steel for automotive, construction and energy industries. According with different sources several materials can be substituted for niobium in the production of HSLA steel and superalloys: vanadium, molybdenum, tantalum, titanium, tungsten, ceramic matrix composites and gallium alloys ((USGS, 2019), (Tercero et al., 2018), (CRM\_InnoNet, 2013)). However, assuming 1:1 substitution in alloys is overly simplistic, for the simple reason that the properties of a given alloy are not controlled by a single metal, but rather by several metals. In addition, each metal may produce a range of effects in the alloy. For example, niobium is used in combination with small amounts of several other metals, including, but not limited to chromium, nickel, copper, vanadium, molybdenum, titanium, calcium, rare earth elements and zirconium, in the production of HSLA steel. The interaction between these additions is complex, but they can be used to modify properties such as strength, toughness, corrosion resistance and formability (Beta Technology, 2016). Therefore, it cannot be reasonably assumed that the increased addition of one of these metals in the absence of niobium would produce a steel with the same properties.

<sup>178</sup> Included in Others (7%) according to CBMM and redistributed among the other applications

Any substitution would be associated with a price and/or performance penalty. In general, there appears to be little economic or technical incentive to substitute niobium in its principal applications.

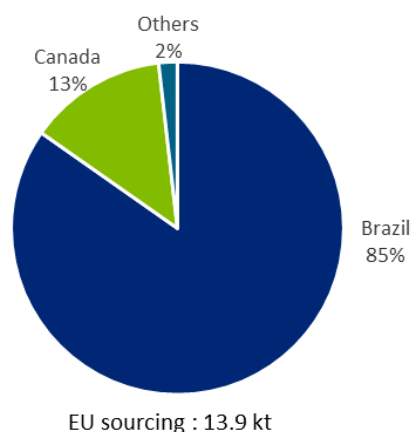
## 18.4 Supply

### 18.4.1 EU supply chain

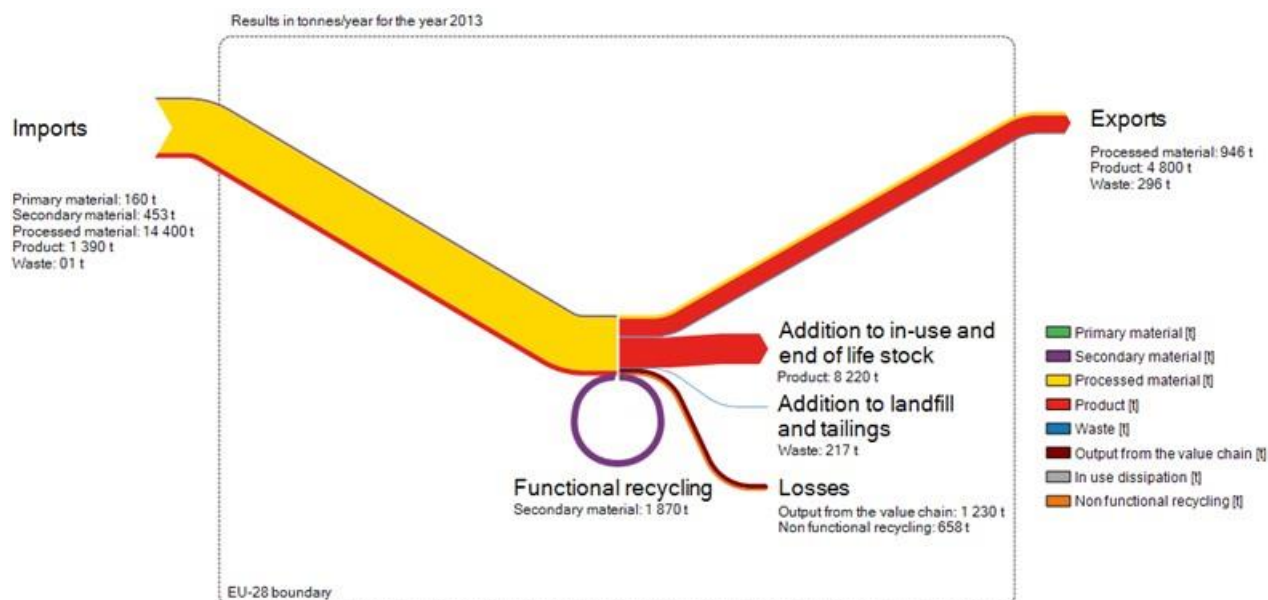
Niobium ores and concentrates are not mined in the EU, nor are they traded within the EU. Ferroniobium is also not produced in the EU, meaning the EU is entirely reliant on ferroniobium imports to meet demand. However, specialist niobium-based alloys (e.g. superalloys) and chemicals (e.g. lithium niobate) are manufactured in Europe, although it is difficult to quantify how much ((BIO Intelligence Service, 2015), (Beta Technology, 2016)). NPM Silmet (Estonia) is a European refiner of niobium producing highly pure niobium. Figure 220 depicts the flows of niobium within the EU economy.

Ferroniobium is primarily used in the production of HSLA steels, with the majority (about 11,000 t) of EU imports going to only eight countries: Austria, Belgium, Germany, France, Finland, Italy, Spain and Sweden. Germany is the largest steel producer in Europe (World Steel Association, 2018) and therefore accounts for the greatest share of ferroniobium imports.

There are currently no export quotas placed on ferroniobium exported to the EU from other countries. However, ferroniobium exports from China entering the EU are subject to an export tax of between 25 and 75% (OECD, 2019).



**Figure 220: EU sourcing (domestic production + imports) of ferroniobium, average 2012-2016 (Eurostat, 2019b), (WMD 2018).**



**Figure 221: Sankey diagram showing the material flows of niobium in the EU economy in 2013 ((BIO Intelligence Service, 2015))**

## 18.4.2 Supply from primary materials

### 18.4.2.1 Geological occurrence/exploration

Niobium deposits are most commonly associated with peralkaline granites or syenites, and/or carbonatites (i.e. an igneous rock that consists of more than 50% primary carbonate minerals). Secondary deposits of niobium, such as laterites, and residual placers, typically form by the weathering of igneous deposits (Dill, 2010). An overview of these deposits is given in Table 99.

Niobium deposits associated with peralkaline granites and syenites are typically less than 100 Mt in size (BGS, 2011) and have ore grades of between 0.1 and 1 wt. % Nb<sub>2</sub>O<sub>5</sub>, contained in ore minerals such as columbite, eudialyte and loparite. Alkaline magmas responsible for the formation of these deposits are derived by melting of enriched sub-continental lithospheric mantle and are typically enriched in the High Field Strength Elements (HFSE) (i.e. niobium, zirconium and rare earth elements). These incompatible (i.e. elements that become concentrated in molten magma rather than early crystallising solid minerals) HFSE are further upgraded by magmatic (e.g. fractional crystallisation) and/or hydrothermal processes (BGS, 2011).

Carbonatite-hosted niobium deposits can be divided into primary and secondary deposit types. Primary deposits are generally in the tens of millions of tonnes size range and typically have ore grades of less than 1 wt. % Nb<sub>2</sub>O<sub>5</sub>. Carbonatites are found in areas of crustal extension or rifting and are thought to be derived from direct melting of the mantle. They are enriched in HFSE (e.g. niobium, zirconium and rare earth elements), but also barium, strontium, thorium and uranium. Important ore minerals in these rocks include perovskite and pyrochlore, and niobium-rich silicates such as titanite (BGS, 2011). Secondary niobium deposits are associated with deep, tropical weathering of carbonatites and are typically very large (up to 1 000 Mt) and have very high ore grades (up to 3 wt. % Nb<sub>2</sub>O<sub>5</sub> in lateritic deposits, but as high as 12 wt. % Nb<sub>2</sub>O<sub>5</sub> in some residual placers). Pyrochlore is the most common ore mineral in these secondary ore deposits (BGS, 2011).

**Table 99: Summary of important niobium deposit types (BGS, 2011)**

<b>Deposit type</b>	<b>Brief description</b>	<b>Typical grades and tonnage</b>	<b>Major examples</b>
<i>Carbonatite-hosted primary deposits</i>	Niobium deposits found within carbonatitic igneous rocks in alkaline igneous provinces	Niobec, proven & probable reserves: 23.5 Mt at 0.59% Nb <sub>2</sub> O <sub>5</sub>	Niobec, Canada; Oka, Canada
<i>Carbonatite-sourced secondary deposits</i>	Zones of intense weathering or sedimentary successions above carbonatite intrusions in which niobium ore minerals are concentrated	< 1 000 Mt at up to 3% Nb <sub>2</sub> O <sub>5</sub> in lateritic deposits. Up to 12% Nb <sub>2</sub> O <sub>5</sub> in placer deposit at Tomtor, tonnage not known	Araxá and Catalão, Brazil; Tomtor, Russia; Lueshe, DRC
<i>Alkaline granite and syenite</i>	Niobium and lesser tantalum deposits associated with silicic alkaline igneous rocks. Ore minerals may be concentrated by magmatic or hydrothermal processes	Generally < 100 Mt, at grades of 0.1 to 1% Nb <sub>2</sub> O <sub>5</sub> and < 0.1% Ta <sub>2</sub> O <sub>5</sub>	Motzfeldt and Ilímaussaq, Greenland; Lovozero, Russia; Thor Lake and Strange Lake, Canada; Pitinga, Brazil; Ghurayyah, Saudi Arabia; Kanyika, Malawi

#### 18.4.2.2 Resources and reserves

Global resources of niobium are about 84 Mt, but occur almost exclusively in Brazil (see Table 100), which currently accounts for about 96% of all global resources (Linnen et al., 2014). World resources of niobium are more than adequate to supply global projected needs (Padilla et al., 2019).

Known global reserves of niobium (as Nb) are estimated to be more than 9,100 kt (Table 100). There are no data about niobium reserves in Europe in the Minerals4EU (2019) website.

**Table 100: Global resources in 2014 (measured and indicated\*) (Linnen et al., 2014) and reserves (proven and probable) of niobium in 2018 (Padilla, 2019)**

<b>Country</b>	<b>Niobium(Nb<sub>2</sub>O<sub>5</sub> content) Resources (kt)</b>	<b>Niobium(Nb content) Reserves (kt)</b>
Brazil	78,133	7,300
Canada	3,005	1,600
Australia	165	N.A.
China	2,200	-
Egypt	4	-
Malawi	174	-
Mozambique	52	-
United States	129	180
<i>World total **</i>	<i>83,861</i>	<i>&gt;9,100</i>

\* Inferred resources are also reported in Brazil, Gabon, Kenya, Canada, Tanzania, Ethiopia, Saudi Arabia, Spain, Angola, Mozambique and the USA.

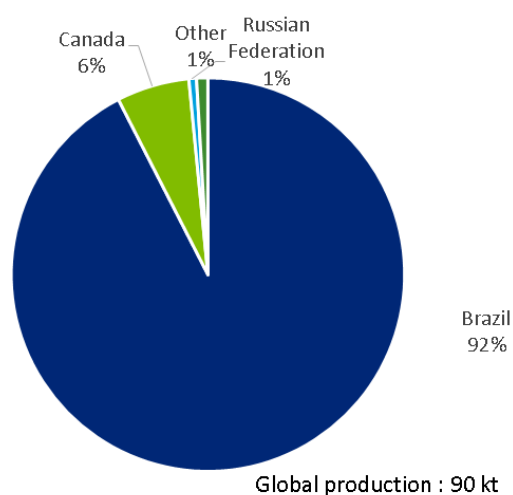
\*\* Some deposits are omitted because no reliable reserve or resource data are available.

**Table 101: Resource data for the EU compiled in the European project SCRREEN Deliverable 3.1 ((Lauri, 2018))**

Country	Quantity (Mt of P <sub>2</sub> O <sub>5</sub> )	Location
Austria	No information	Occurrences associated with granitic pegmatites, which contain niobium
Czech Republic	No information	Occurrences mainly related to granitic pegmatites that contain Nb and Ta minerals
Finland	250 Mt of ore at 0.21 % Nb	Sokli P-Fe-Nb deposit
	8.15 Mt of ore with Nb oxide contents ranging from 0.12 % to 0.76 % and a calculated total amount of 13 000 t Nb <sub>2</sub> O <sub>5</sub>	Jokikangas, Katajakangas and Kontioaho
France	1 860 t of Nb <sub>2</sub> O <sub>5</sub>	Tréguennec deposit
	No information	There are other Nb and Ta-bearing mineral occurrences in France, which are mostly in granitic pegmatites
Germany	No information	Deposits and occurrences hosted by granitic and alkaline rocks
Italia	No information	There are over ten Nb-Ta occurrences in Italy that are hosted by granitic pegmatites.
Malta	No information	One sedimentary phosphorite occurrence
Netherlands	No information	Two sedimentary phosphorite occurrence
Portugal	350 t Nb <sub>2</sub> O <sub>5</sub>	Almendra deposit
Slovakia	No information	Four deposits with both niobium and tantalum as the main commodities, which are hosted by granitic pegmatites

### 18.4.2.3 World mine and refining production

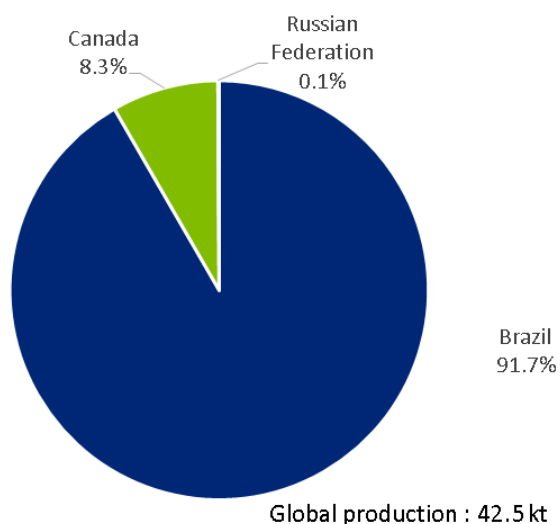
Global extraction of niobium ores and concentrates takes place in 11 countries and averages 90.0 kt per annum over the period 2012-2016 and 81.7 kt in 2017. However, production is heavily concentrated, with about 92 % of world production taking place in Brazil. Canada accounts for about 6 % of the global total and nine countries, Russia, Democratic Republic of Congo, Rwanda, Nigeria, Burundi, China, Ethiopia, Mozambique and Uganda account for the remaining 2 % (WMD, 2019)



**Figure 222: Global mining production of niobium, averaged over 2012-2016 (WMD, 2019).**



With the exception of the African countries listed above, companies extracting niobium ores are typically integrated, meaning they also produce processed niobium products, such as niobium oxide, ferroniobium and niobium metal. Average global production of ferroniobium during the 2012-2016 period was almost 42.5 kt per annum (average 2012 to 2016). Figure 223 shows global ferroniobium production only took place in only two countries, Brazil and Canada.



**Figure 223: Global production of ferroniobium, averaged over 2012-2016 (BGS, 2019).**

The main companies producing Niobium are reported in Table 102. It is important to highlight that the largest deposit in the world is located in Araxa (Brazil) and is owned by Companhia Brasileira de Metalurgia e Mineracao (CBMM).

**Table 102: The tree largest world producers of niobium (TIC, 2019).**

Company	Mine site (location)
Companhia Brasileira de Metalurgia e Mineração (CBMM)	Araxa, Brazil
China Molybdenum previously owned by Anglo American Niobio Brasil	Catalao, Goias state, Brazil
IAMGOLD Corp	Niobec Mine in Quebec, Canada

### 18.4.3 Supply from secondary materials/recycling

According to the United Nations Environment Programme (UNEP) the End of Life (EoL) recycling input rate for niobium, chiefly as a constituent of ferrous (e.g. steel) scrap, is greater than 50% (Reuter, 2013). However, the amount of niobium physically recovered from scrap (i.e. functional recycling) is negligible, with estimates by BIO Intelligence Service (2015) by Deloitte given at less than 1%, i.e. 0.3% (Validation workshop 2019). In 2018, Strategic Minerals Spain (SMS) started the processing of tailings from waste-rock heaps and ponds of the old Penouta mine leading to the obtaining of tantalum and niobium minerals through a gravimetric separation process, without any chemical products or

waste that is harmful to the environment. It is estimated that the mineral resources in the remaining original deposit amount to 95.5 Mt of Measured and Indicated Mineral Resources with average grades of 77 ppm Ta and 443 ppm Sn, and in the old tailing waste-rock heaps where the company has started operations 12 Mt of resources with average grades of 35 ppm Ta and 428 ppm Sn<sup>179</sup>.

**Table 103: Material flows relevant to the EOL-RIR of Niobium, data from 2012 (BIO Intelligence Service, 2015)**

MSA Flow	Value (t)
B.1.1 Production of primary material as main product in EU sent to processing in EU	0.00
B.1.2 Production of primary material as by product in EU sent to processing in EU	0.00
C.1.3 Imports to EU of primary material	159974.00
C.1.4 Imports to EU of secondary material	452702.00
D.1.3 Imports to EU of processed material	14368682.00
E.1.6 Products at end of life in EU collected for treatment	757471.00
F.1.1 Exports from EU of manufactured products at end-of-life	1284.00
F.1.2 Imports to EU of manufactured products at end-of-life	543.00
G.1.1 Production of secondary material from post consumer functional recycling in EU sent to processing in EU	43896.00
G.1.2 Production of secondary material from post consumer functional recycling in EU sent to manufacture in EU	0.00

#### 18.4.4 Processing of Niobium

Niobium is mainly mined as the primary ore. Near-surface niobium deposits are typically exploited by open-pit mining methods, which commonly involve removing overburden, digging or blasting the ore, followed by removal of the ore by truck or conveyor belt for stockpiling prior to processing. Deeply buried niobium deposits are mined underground using conventional mining methods, such as room and pillar, where mining progresses in a horizontal direction by developing numerous stopes, or rooms, leaving pillars of material for roof support. Ore is blasted and then transported by rail, conveyor or dump truck to the processing plant.

Regardless of the mining method employed niobium ores are first crushed in jaw, cone or impact crushers and milled in rod or ball mills operating in closed circuits with vibrating screens and screw classifiers to liberate niobium mineral particles. The slurry containing niobium and waste rock is further concentrated to around 54% niobium oxide using a number of methods in multiple stages: gravity separation, froth flotation, magnetic and electrostatic separation, and acid leaching may be used, depending on the physical and chemical characteristics of the ore (BGS, 2011).

Typically, niobium ores from carbonatite-associated deposits are screened, classified, and deslimed (i.e. removal of very fine particles). Carbonate material is removed by froth flotation, followed by an additional desliming stage. Magnetite is removed by low-intensity magnetic separation, and sent to waste. The sought-after pyrochlore is collected by froth flotation. A final stage of froth flotation is used to remove sulphides, such as pyrite. Residual impurities may be leached by hydrochloric acid, leaving a final concentrate that contains about 54% niobium pentoxide ((IAMGOLD, 2019); (BGS, 2011)).

<sup>179</sup> Blengini, G.A.; Mathieux, F.; Mancini, L.; Nyberg, M.; Viegas, H.M. (Editors); Salminen, J.; Garbarino, E.; Orveillon, G.; Saveyn, H.; Mateos Aquilino, V.; Llorens González, T.; García Polonio, F.; Horckmans, L.; D'Hugues, P.; Balomenos, E.; Dino, G.; de la Feld, M.; Máдай, F.; Földessy, J.; Mucsi, G.; Gombkötő, I.; Calleja, I. Recovery of critical and other raw materials from mining waste and landfills: State of play on existing practices, EUR 29744 EN, Publications Office of the European Union, Luxembourg, 2019, ISBN 978-92-76-08568-3, doi:10.2760/600775, JRC116131.

Niobium concentrates are further refined by hydrometallurgical processes to produce niobium fluorides, oxides or chlorides. These compounds can then be converted to niobium metal by electrometallurgical (e.g. electrolysis) or pyrometallurgical (e.g. aluminothermic reaction) processes. Ferroniobium, containing 65–66% niobium, is also produced by aluminothermic reaction, but with the addition of iron oxide powder. Niobium carbide is produced by high temperature sintering of niobium oxide powder with carbon (Albrecht, 1989;BGS, 2011).

## 18.5 Other considerations

### 18.5.1 Environmental and health and safety issues

In its native form niobium is fairly inert and poses few, if any, environmental or human health. No environmental or social problems were found for the production of niobium.

## 18.6 Comparison with previous EU assessments

Niobium criticality was also assessed in 2011, 2014 and 2017. It was always found to be a critical raw material, because the applications where niobium is used are of high economic importance to the EU and the supply is highly concentrated in Brazil (92% of global production, averaged over 2012-2016). However, the available resources are more than sufficient to cover supply and according with CBMM (2019) stockpiles were created for EU industry consumers to avoid any problems of supply.

The 2020 assessment has been conducted using the same methodology as for the 2017 list. The results of this and earlier assessments are shown in Table 104.

**Table 104: Economic importance and supply risk results for niobium in the assessments of 2011, 2014, 2017, 2020 (European Commission, 2011), (European Commission, 2014),(European Commission, 2017)**

Assessment	2011		2014		2017		2020	
	EI	SR	EI	SR	EI	SR	EI	SR
Niobium	8.95	2.80	5.87	2.46	4.8	3.1	6.0	3.9

Although it appears that the economic importance (EI) of niobium has reduced between 2014 and 2017 this is a false impression created by the change in methodology. The value added in the 2017 criticality assessment corresponds to a 2-digit NACE sector rather than a 'megasector', which was used in the 2011 and 2014 assessments. The economic importance figure is therefore reduced. The supply risk (SR) score is higher compared to the previous assessments, which is due to the revised methodology and the way the supply risk is calculated. Therefore, differences between 2014 and 2017 assessments are largely due to changes in methodology (as outlined above) and the form of the commodity that has been assessed, that is the most recent assessment was based on the production and trade of ferroniobium. The 2020 results show an increase of the EI due to a redistribution of the end use sectors, which better represent the applications of niobium in the EU industry. The value for supply risk suffers a small increase due to updates on the substitutes of niobium in comparison with the values of 2017.

## 18.7 Data sources

---

Production data for ferroniobium was based on BGS World mineral statistics data (Beta Technology, 2016). EU trade data were taken from the Eurostat COMEXT online database (Eurostat, 2019b) using the Combined Nomenclature (CN) code 7202 9300 (ferroniobium). Data were averaged over the five-year period 2010–2014 inclusive.

### 18.7.1 Data sources used in the factsheet

Albrecht, W. W. (1989). Production, Properties and Application of Tantalum, Niobium and Their Compounds. In *Lanthanides, Tantalum and Niobium* (pp. 345–358). [https://doi.org/10.1007/978-3-642-87262-4\\_18](https://doi.org/10.1007/978-3-642-87262-4_18)

Beta Technology. (2016). Personal Communication regarding ferroniobium production and trade [November 2016].

BGS. (2019). World mineral statistics data. Retrieved July 30, 2019, from British Geological Survey website: <https://www.bgs.ac.uk/mineralsuk/statistics/wms.cfc?method=searchWMS>

BIO Intelligence Service. (2015). Study on Data for a Raw Material System Analysis: Roadmap and Test of the Fully Operational MSA for Raw Materials. Retrieved from <https://ec.europa.eu/jrc/en/scientific-tool/msa>

British Geological survey, B. (2011). Niobium-tantalum commodity profile.

CBMM. (2019). Personal Communication, after the CRM validation workshop on the 12th of September 2019.

CRM\_InnoNet. (2013). Critical Raw Materials Substitution Profiles. Retrieved from <http://cdn.awsripple.com/www.criticalrawmaterials.eu/>

DERA and BGR. (2019). Preismonitor September 2019.

Dill, H. G. (2010, June). The “chessboard” classification scheme of mineral deposits: Mineralogy and geology from aluminum to zirconium. *Earth-Science Reviews*, Vol. 100, pp. 1–420. <https://doi.org/10.1016/j.earscirev.2009.10.011>

European Commission. (2011). Critical raw materials. Retrieved July 8, 2019, from [https://ec.europa.eu/growth/sectors/raw-materials/specific-interest/critical\\_en](https://ec.europa.eu/growth/sectors/raw-materials/specific-interest/critical_en)

European Commission. (2014). Report on critical raw materials for the EU - Critical raw materials profiles. Retrieved from <https://ec.europa.eu/docsroom/documents/11911/attachments/1/translations/en/renditions/pdf>

European Commission. (2017). Study on the review of the list of critical raw materials. Non-critical raw materials factsheets. <https://doi.org/10.2873/876644>

Eurostat. (2019a). Annual detailed enterprise statistics for industry (NACE Rev. 2, B-E). Retrieved July 7, 2019, from [https://ec.europa.eu/eurostat/en/web/products-datasets/-/SBS\\_NA\\_IND\\_R2](https://ec.europa.eu/eurostat/en/web/products-datasets/-/SBS_NA_IND_R2)

Eurostat. (2019b). Easy Comext database. Retrieved from <http://epp.eurostat.ec.europa.eu/newxtweb/>

IAMGOLD. (2019). Niobec Niobium Mine, Quebec. Retrieved from [www.iamgold.com](http://www.iamgold.com)

- Lauri, L. (2018). SCREEN D3.1 Identification and quantification of primary CRM resources in Europe. Retrieved from <http://screen.eu/results/>
- Linnen, R., Trueman, D.L. and Burt, R. (2014). Tantalum and niobium in Critical Metals Handbook (G. Gunn, Ed.). <https://doi.org/10.1002/9781118755341>
- LUIS TERCERO ESPINOZA, ANTONIA LOIBL, S. L., ARJAN DE KONING, E. V. D. V., & MICHAUX, S. (2018). SCREEN D2.3 REPORT ON THE FUTURE USE OF CRITICAL RAW MATERIALS.
- Minerals4EU. (2015). European Minerals Yearbook. Retrieved July 9, 2019, from [http://minerals4eu.brgm-rec.fr/m4eu-yearbook/theme\\_selection.html](http://minerals4eu.brgm-rec.fr/m4eu-yearbook/theme_selection.html)
- OECD. (2019). Export restrictions on Industrial Raw Materials. Retrieved July 5, 2019, from [https://qdd.oecd.org/subject.aspx?Subject=ExportRestrictions\\_IndustrialRawMaterials](https://qdd.oecd.org/subject.aspx?Subject=ExportRestrictions_IndustrialRawMaterials)
- Reuter, M. (2013). Metal Recycling Opportunities, Limits, Infrastructure. UNEP.
- Rudnick, R. L., & Gao, S. (2013). Composition of the Continental Crust. In *Treatise on Geochemistry: Second Edition (2nd ed., Vol. 4)*. <https://doi.org/10.1016/B978-0-08-095975-7.00301-6>
- Tantalum-Niobium International Study Center (T.I.C.). (2019). Tantalum-Niobium International Study Center | TIC. Retrieved November 12, 2019, from <https://www.tanb.org/index>
- Tercero, L., Stotz, H., Otmar Deubzer, García, R. B., Lepe, G. R., Bilewska, K., ... Hu, X. (2018). SCREEN D5.1 Critical Raw Material substitution profiles. In SCREEN - D5.1. Retrieved from <http://screen.eu/wp-content/uploads/2018/05/SCREEN-D5.1-CRM-profiles.pdf>
- TIC. (2019). Niobium Minerals & Production | TIC. Retrieved November 12, 2019, from <https://www.tanb.org/about-niobium/raw-materials>
- USGS. (2019). Mineral Commodity Summaries 2019. <https://doi.org/10.1007/978-3-540-47108-0-4>
- WMD (2019) World Mining Data 2019, Reichl, C.; Schatz, M; Zsak, G. Iron and Ferro Alloy Metals, non Ferrous Metals, Precious Metals, Industrial Minerals, Mineral Fuels. Austrian Federal Ministry of Sustainability and Tourism. [online] Available at: [www.en.bmwf.at/Energy/WorldMiningData/Seiten/default.aspx](http://www.en.bmwf.at/Energy/WorldMiningData/Seiten/default.aspx)
- World Steel Association. (2018). STEEL STATISTICAL YEARBOOK 2018.

### **18.7.2 Data sources used in the criticality assessment**

- BGS. (2019). World mineral statistics data. Retrieved July 30, 2019, from British Geological Survey website: <https://www.bgs.ac.uk/mineralsuk/statistics/wms.cfc?method=searchWMS>
- BIO Intelligence Service. (2015). Study on Data for a Raw Material System Analysis: Roadmap and Test of the Fully Operational MSA for Raw Materials. Retrieved from <https://ec.europa.eu/jrc/en/scientific-tool/msa>
- European Commission. (2017). Study on the review of the list of critical raw materials. Non-critical raw materials factsheets. <https://doi.org/10.2873/876644>

European Commission (2019) Negotiations and agreements - Trade. Available at: <http://ec.europa.eu/trade/policy/countries-and-regions/negotiations-and-agreements/> (Accessed: 7 July 2019).

Eurostat. (2019a). Annual detailed enterprise statistics for industry (NACE Rev. 2, B-E). Retrieved July 7, 2019, from [https://ec.europa.eu/eurostat/en/web/products-datasets/-/SBS\\_NA\\_IND\\_R2](https://ec.europa.eu/eurostat/en/web/products-datasets/-/SBS_NA_IND_R2)

Eurostat. (2019b). Easy Comext database. Retrieved from <http://epp.eurostat.ec.europa.eu/newxtweb/>

OECD. (2019). Export restrictions on Industrial Raw Materials. Retrieved July 5, 2019, from [https://qdd.oecd.org/subject.aspx?Subject=ExportRestrictions\\_IndustrialRawMaterials](https://qdd.oecd.org/subject.aspx?Subject=ExportRestrictions_IndustrialRawMaterials)

Nassar et al. (2015) Yale University, By-product metals are technologically essential but have problematic supply. Available at: (<https://advances.sciencemag.org/content/1/3/e1400180>) (Accessed: 15 April 2019)

Tercero, L., Stotz, H., Otmar Deubzer, García, R. B., Lepe, G. R., Bilewska, K., ... Hu, X. (2018). SCRREEN D5.1 Critical Raw Material substitution profiles. In SCRREEN - D5.1. Retrieved from <http://screen.eu/wp-content/uploads/2018/05/SCRREEN-D5.1-CRM-profiles.pdf>

USGS. (2019). Mineral Commodity Summaries 2019. <https://doi.org/10.1007/978-3-540-47108-0-4>

WMD (2019) World Mining Data 2019, Reichl, C.; Schatz, M; Zsak, G. Iron and Ferro Alloy Metals, non Ferrous Metals, Precious Metals, Industrial Minerals, Mineral Fuels. Austrian Federal Ministry of Sustainability and Tourism. [online] Available at: [www.en.bmwf.gv.at/Energy/WorldMiningData/Seiten/default.aspx](http://www.en.bmwf.gv.at/Energy/WorldMiningData/Seiten/default.aspx)

## **18.8 Acknowledgments**

---

This factsheet was prepared by the JRC. The authors would like to thank CBMM, the EC Ad Hoc Working Group on Critical Raw Materials and all other relevant stakeholders for their contributions to the preparation of this Factsheet.

# 19 PLATINUM-GROUP METALS

## 19.1 Overview

---

### 19.1.1 Overview of platinum group metals in general

Platinum Group Metals (PGMs), sometimes referred to as the platinum-group elements (PGE), comprise six elements: platinum (Pt), palladium (Pd), rhodium (Rh), ruthenium (Ru), iridium (Ir) and osmium (Os). The platinum group metals show very similar chemical properties, while their physical properties vary. Common characteristics of the PGMs, which are the basis of most of their applications, include outstanding catalytic activity, very high resistance to corrosion and oxidation ("noble metals"), very high melting point, high density, excellent electrical conductivity, general non-toxicity (except Os), ability to form alloys, excellent resistance to wear and tarnish, and stability to high temperatures. The PGMs are considered as precious metals, like gold and silver; nevertheless, they are widely used metals and essential for certain industrial applications. The PGM are scarce natural resources that occur together in nature. Platinum and palladium are of major commercial significance, with rhodium the next most important. Given the greater commercial importance and use of platinum and palladium, there is generally much more information available on platinum and palladium than for the other three PGMs. Osmium is a little-used, toxic metal, for which there is virtually no quantitative data on any part of its value chain. For this reason, it is not feasible to carry out a quantitative criticality assessment using the methodology employed in the 2017 criticality assessment.

This factsheet deals essentially with the PGMs as a group of metals, illustrating the commonalities of the group. This "general factsheet", while their particularities are addressed in five metal "specific factsheets". Quantitative information on PGMs in this factsheet are usually aggregates of the figures shown in the specific factsheets. For further information on individual PGMs and their criticality assessment, please refer to the factsheets for platinum, palladium, rhodium, ruthenium and iridium.

Due to the geographic location of PGM reserves, the PGM mining activities are concentrated in very few countries. The lower number of mines and the high grade of specialisation required, results in a low number of companies mining and refining PGMs. In the short term, the introduction of stricter emission standards for motor vehicles is expected to contribute to the demand for platinum, palladium and rhodium used in the fabrication of autocatalysts. An increase in the adoption of fuel cells technology is expected to be supportive for platinum demand.

PGM prices are high and typically volatile because of the limited availability in nature, and the low flexibility for accommodating rapid changes in demand.

The global demand for PGMs for all applications is about 635 tonnes per year (average over the period 2016-2018).

PGMs are of great importance in many modern technologies and products. The catalytic properties of PGMs are the basis of their most important applications in emission control systems in vehicles and in industrial process catalysts for bulk-chemical manufacture and petroleum refining. Other applications include electronics, glass manufacturing, jewellery, dental and medical special alloys. There are no effective substitutes that provide the same performance as the PGMs. In many applications, a PGM can substitute for another one. Platinum and palladium can be interchanged to a certain extent in autocatalysts, depending on the prices and demand/supply for each; however, they cannot be considered fully substitutable.

The global known PGM resources are estimated to be in excess of 100,000 tonnes. South Africa hosts by far the world's most abundant resources (68% of the total), while Russia and Zimbabwe also hold a significant proportion of global PGM resources of 17% and 9%, respectively. Reserves of PGM are estimated at 17,000 tonnes, with a similarly high geographical concentration and distribution as resources. 92% of the world PGM reserves are located in South Africa, Russia, and Zimbabwe together (Mudd, Jowitt and Werner, 2018).

PGMs are scarce natural resources produced in low volumes. Global primary production of PGMs in 2017 amounted to 447 tonnes (182 tonnes platinum; 208 tonnes palladium; 23 tonnes rhodium, 34 tonnes iridium and ruthenium). The largest primary supplier of PGMs worldwide is South Africa, followed by Russia. Supply from South Africa is dominated by platinum and supply from Russia by palladium. South Africa is also the main supplier of the 'minor' PGMs: rhodium, ruthenium, and iridium. The PGM primary production is highly concentrated, as South Africa and Russia together produce around 82% of the world total, with the remainder coming predominantly from Zimbabwe and North America (Canada and United States). Less than 2 tonnes are produced annually in the EU, mainly in Finland as a by-product of nickel and copper mining.

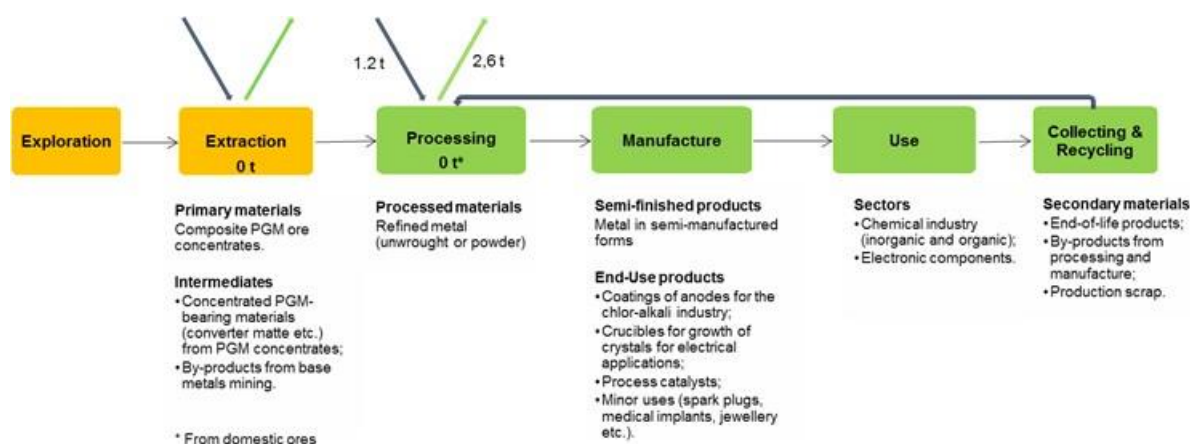
Due to the high PGM prices, the supply of PGMs from recycling makes an important contribution to keeping up with global demand. Many parameters govern recycling efficiency for PGMs. The main secondary materials are spent automotive exhaust catalysts, spent chemical catalysts, and electronic and electrical component scrap. Automotive catalysts represent the main source of secondary material in the EU. PGM recycling from industrial applications achieves higher recycling rates in comparison to open-loop recycling of end-of-life products.

Platinum, and to a lesser extent iridium and ruthenium, are important materials for the transition to a climate economy. These materials are used in fuel cells and hydrogen technologies for energy generation and storage in transport and stationary applications.

Escalating costs, underinvestment and labour disputes in the PGM industry of South Africa are remaining concerns for the security of supply of PGMs worldwide.

## 19.1.2 Overview of individual platinum group metals

### 19.1.2.1 Overview of iridium



**Figure 224: Simplified value chain for iridium (average 2012-2016)**

Iridium (Ir, atomic number 77) is one of the six chemical elements referred to as the platinum-group metals (PGM), which are, in order of increasing atomic number: ruthenium



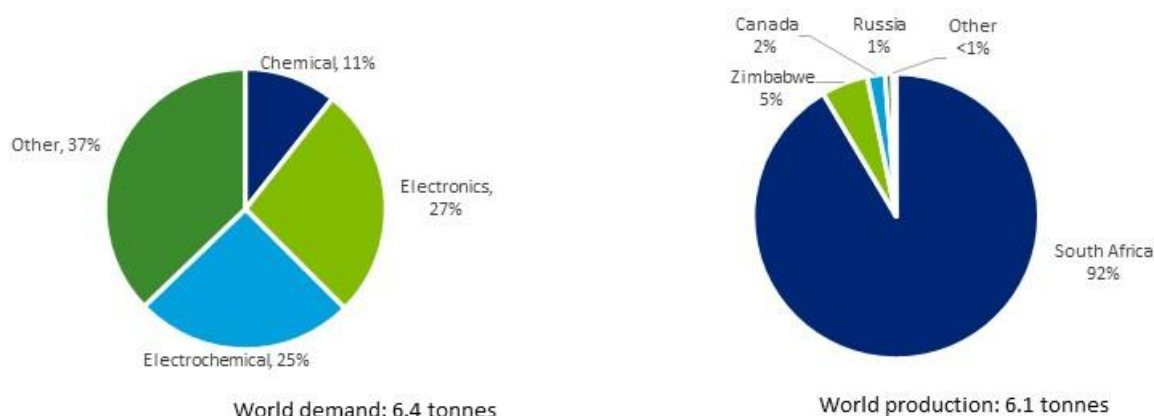
(Ru), rhodium (Rh), palladium (Pd), osmium (Os), iridium (Ir) and platinum (Pt). Iridium is a silver-white metal, though with a yellowish hue, and has a very high melting point of 2,443 °C, the highest among PGM (excluding osmium). After osmium, iridium is the second most dense of the known elements with a density of 22.55 g/cm<sup>3</sup> (by comparison almost twice as dense as lead and three times denser than iron). It is also the most corrosion-resistant metal known. Iridium is extremely hard and brittle (6.5 hardness on the Mohs scale), over four times harder than platinum, therefore challenging to work unless it is heated to very high temperatures. Iridium has exceptional electrical conductivity (almost two times higher than platinum and palladium) and excellent biological compatibility. Because of the difficulties in fabrication, iridium is chiefly used in the form of platinum alloys as it improves considerably platinum's hardness.

This factsheet is complementary to general PGM factsheet presenting additional information and data specific to iridium where available.

The trade code used in the assessment is HS 711041 "Iridium, osmium & ruthenium, unwrought or in powder form". The relative proportion of ruthenium and iridium in the trade flows was calculated under the assumption of being proportional to their average market size in the period 2012-2016. Annual data for global ruthenium and iridium demand were sourced from Johnson Matthey statistics.

Iridium, as ruthenium, is of lower commercial importance compared to platinum, palladium, and rhodium. Global supply is highly concentrated in terms of both mine production and secondary recovery. The top importer worldwide of the "minor PGMs" (iridium, ruthenium, and osmium) in unwrought and powder form is Japan, and in semi-manufactured forms the United States and China. As concerns the leading exporting countries, for unwrought metal and powder is South Africa and Germany, and for semi-manufactured forms the UK and South Africa.

The market for iridium is small and illiquid and subject to high price volatility. In 2018, the price of iridium reached a record level of US\$1,480 per troy ounce.



**Figure 225: Global end uses of iridium (average 2012-2016), and estimated world mine production (average 2012-2016).**

The world demand for iridium averaged 6.4 tonnes annually in the years 2012-2016. The import reliance for iridium from primary sources is 100%. However, the EU is an important global supplier of refined iridium metal originating from secondary materials collected domestically or imported, and the actual net import reliance is lower. In the period 2012-2016, South Africa and the United Kingdom were the main source countries for EU imports of iridium in unwrought or powder form by similar shares of almost 40% each.

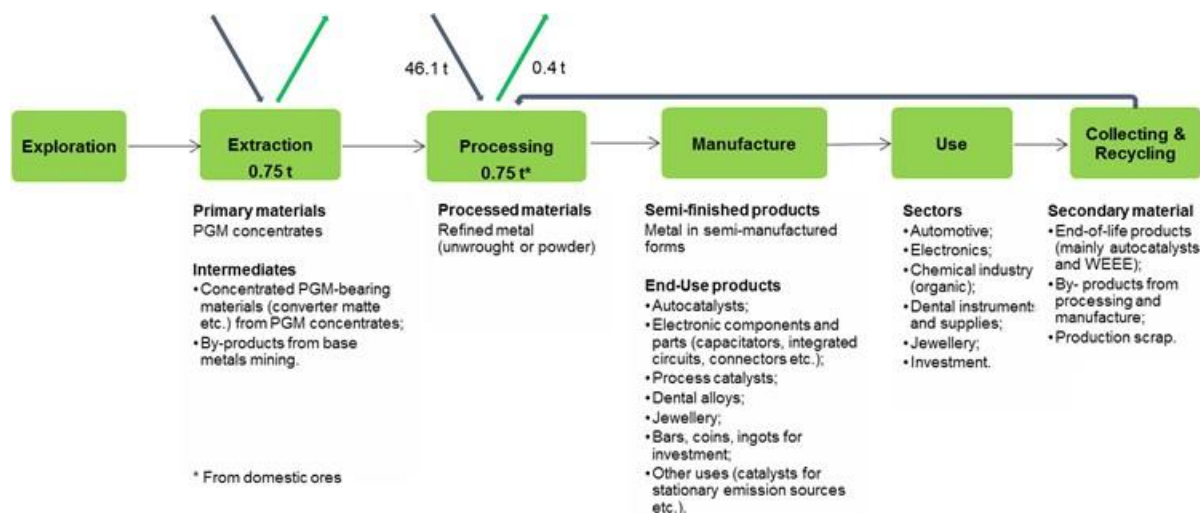
The significant uses of iridium are in electronics, i.e. crucibles for growing single crystals for lasers, scanners, LEDs and other applications, anodes for the chlor-alkali industry which produces chlorine and caustic soda, and process catalysts for the chemical industry. Potential substitutes for crucibles include molybdenum and tungsten, ruthenium in the chlor-alkali industry, and rhodium for process catalysts.

South Africa hosts the majority of PGM resources with iridium occurrences. Iridium also occurs in PGM deposits in Zimbabwe and Russia. Iridium resources and reserves are not publicly available.

The annual mine production of iridium worldwide is estimated at about 6 tonnes. South Africa dominates the world mine production with a share of over 90% where iridium originates from platinum group-metal mining operations as co-product. Small quantities are also produced in mines in Zimbabwe, Canada and Russia. No primary production occurs in the EU. The end-of-life recycling input rate of iridium is approximated at 14%. Iridium is mostly recovered from process catalysts.

Applications of iridium in low-carbon technologies are identified in platinum catalysts for fuel cells (polymer electrolyte membrane), as well as in energy-efficient lighting (OLEDs).

### 19.1.2.2 Overview of palladium



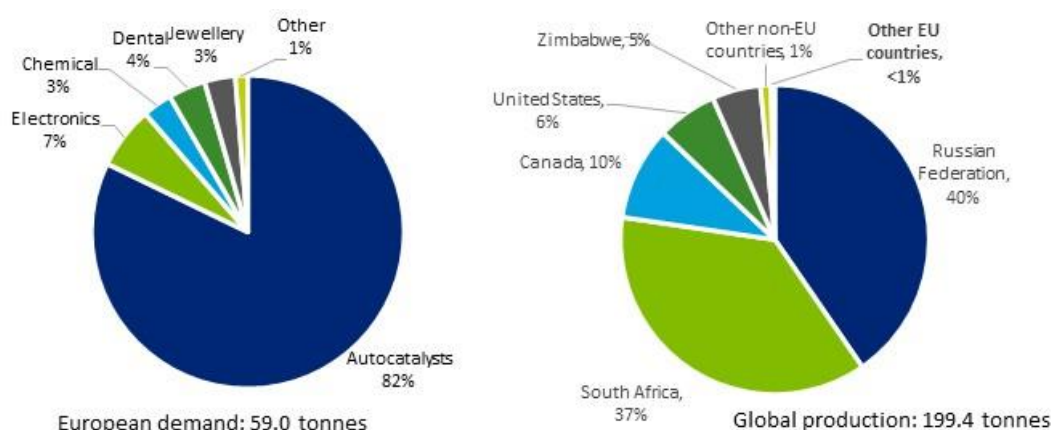
**Figure 226: Simplified value chain for palladium**

Palladium (Pd, atomic number 46) is one of the six chemical elements of the platinum-group metals (PGM), which are, in order of increasing atomic number: ruthenium (Ru), rhodium (Rh), palladium (Pd), osmium (Os), iridium (Ir) and platinum (Pt). Palladium is a shiny silver-grey metal and the least dense of the PGM with a density of 12.02 g/cm<sup>3</sup> (compared to 21.45 g/cm<sup>3</sup> for platinum), about the same as silver. It also has the lowest melting point of the PGM (1,554 °C compared to 1,769 °C for platinum), but it is still high compared with common metals. Palladium is slightly harder than platinum (4.75 hardness on the Mohs scale) but ductile and smoothly worked when annealed. It has significant temperature stability and resistance to oxidation and corrosion, even though lower than platinum and the rest of the PGM; it oxidises in the air at 800 °C, dissolves slowly in strong acids and reacts with several nonmetallic elements on heating (e.g. sulphur). Lastly, like all PGM, palladium has unique catalytic properties, and, additionally, metallic palladium is capable of absorbing up to 900 times its volume of hydrogen. Palladium is often used as an alloy, including other PGM as alloying elements.

The trade code used in the assessment was the HS 711021 "Palladium, unwrought or in powder form".

Palladium and platinum, are the most commercially important of the PGM. The market supply from primary sources is highly concentrated in Russia and South Africa, which have a combined share of nearly 80% of the world mine output. Russia is the leading world exporter of palladium in unwrought and powder form, followed by the UK, South Africa and the US. The palladium market remains in deficit since 2011, which is reflected in higher prices. The growth of the electric vehicle market could reduce demand for palladium over time, though hybrid technology is still reliant on these Pd catalysts to control emissions.

The price of palladium has fluctuated considerably in recent years. Since the beginning of 2016, palladium's price has surged, and it exceeded platinum's price for the first time in more than 15 years in October 2017. Palladium's price climbed at a record level of EUR 1,455 per troy ounce in September 2019, widening the price gap with platinum considerably.



**Figure 227: End uses of palladium in Europe (average 2012-2016), and world palladium mine production (average 2012-2016)**

The annual palladium demand in Europe amounted to 59 tonnes, averaged over the period 2012-2016. The EU consumption of palladium metal in unwrought or powder form is estimated at 46.5 tonnes per year in the same period, mostly sourced through imports. Imports of semi-manufactured forms of palladium also contribute to the EU demand, as well as production from secondary sources. Import reliance for unwrought palladium and palladium powder is estimated to 98%, excluding consumption of refined palladium metal originating from secondary materials which is produced domestically. In the period 2012-2016, Russia (27% of the total imports) and the UK (24% of the total imports) were the main source countries for EU imports of palladium in unwrought or powder form.

By far the leading application of palladium is in catalytic converters for gasoline-powered vehicles. Besides autocatalysts, other important applications are in electronics, process catalysts for the petrochemical and chemical industry, dental alloys and jewellery. Palladium can be substituted for platinum in gasoline-engine autocatalysts.

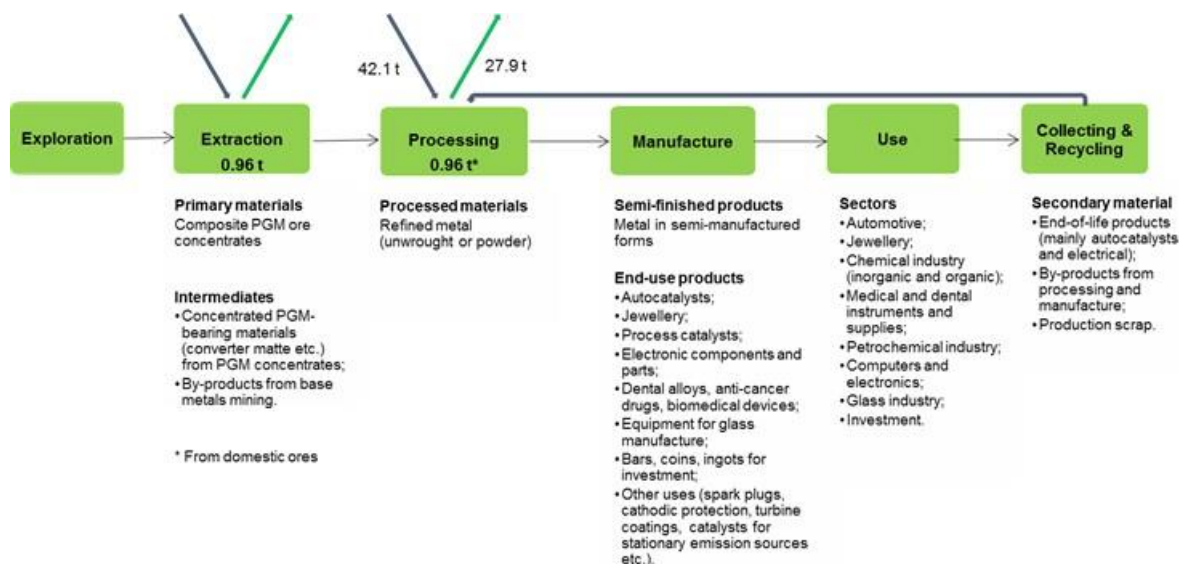
World reserves of palladium are estimated to 7,200 tonnes in Pd content. About 44% of these reserves are located in South Africa and 41% in Russia.

The average annual mine production worldwide is estimated at 199 tonnes for the period 2012-2016. Russia is the leading mine producer with a share of 40% in the period as mentioned above, whereas South Africa is the second world producer with a share of 37% of the world mine production. EU mine production makes a small contribution to European palladium supply with an annual output of less than one tonne, of which about 97% is

produced in Finland and the remainder in Poland. The secondary supply of platinum is based on the recycling of spent autocatalysts and old jewellery.

No specific low-carbon technology related to palladium is identified that can be considered a key for the transition to a climate-neutral economy by 2050.

### 19.1.2.3 Overview of platinum



**Figure 228: Simplified value chain for platinum**

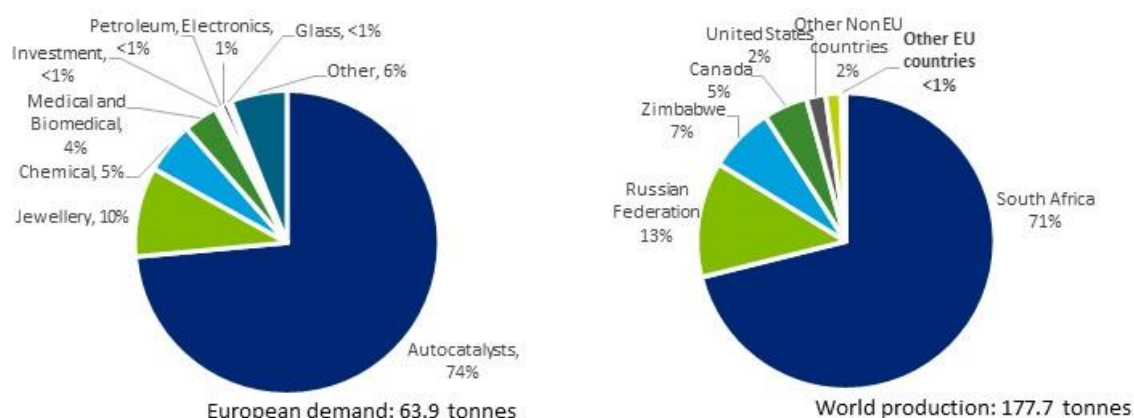
Platinum (Pt, atomic number 78) is one of the six chemical elements comprising the platinum-group metals (PGM). In order of increasing atomic number, the elements ruthenium (Ru), rhodium (Rh), palladium (Pd), osmium (Os), iridium (Ir), and platinum (Pt) are clustered under the term PGM. Platinum has a density of 21.45 g/cm<sup>3</sup>, and together with iridium and osmium are the densest known metals, being about 10% denser than gold and nearly twice as dense as silver or lead. Platinum has exceptional catalytic properties and is relatively soft (4.3 hardness in Mohs scale) and ductile, making it malleable enough to be worked into intricate shapes or stretched into fine wires. As it is extremely resistant to chemical corrosion and oxidation – it is practically unreactive - and has a high melting point of about 1,770 °C, platinum maintains its performance in even the most demanding operating conditions at high temperatures. Due to its lustrous silver-white colour and resistance to wear and tarnish, platinum is well suited for making jewellery. Platinum is mostly used as an alloy. Its working characteristics, hardness and wear properties are optimised by alloying it with other PGM such as iridium and ruthenium.

The trade code used in the assessment was the HS 711011 "Platinum, unwrought or in powder form".

Platinum and palladium are the most significant PGMs in commercial importance. The market supply of platinum from primary sources is highly concentrated in South Africa. South Africa and the United Kingdom hold the largest shares in the world market for exports of platinum in unwrought/powder form, accounting for 25% and 21% respectively of total exports by value in 2017. Germany is the largest importer globally for platinum in unwrought/powder form. In the longer term, it has been suggested that global demand may require significant increases in platinum production because of platinum's use in emerging technologies, e.g. fuel cell electric vehicles.

Since mid-2011 platinum's price is following a declining trend. In October 2017 platinum's price became lower than palladium's price for the first time since 2001. In August 2018

the monthly average price was about EUR 700 per troy ounce, the lowest since December 2008.



**Figure 229: End uses of platinum in Europe (average 2012-2016), and world platinum mine production (average 2012-2016).**

The average annual European demand for platinum was about 64 tonnes in the period 2012-2016, and the average yearly world demand was approximately 178 tonnes in the same period. EU mine production makes a small contribution to European platinum supply. The EU import reliance for platinum in unwrought or in powder form is 94%, excluding consumption of refined platinum metal originating from secondary materials which is produced domestically. However, the EU is dependent on imports of platinum waste and scrap. In the period 2012-2016, South Africa (42% of the total imports) and the UK (25% of the total imports) were the main source countries for EU imports of platinum in unwrought or powder form.

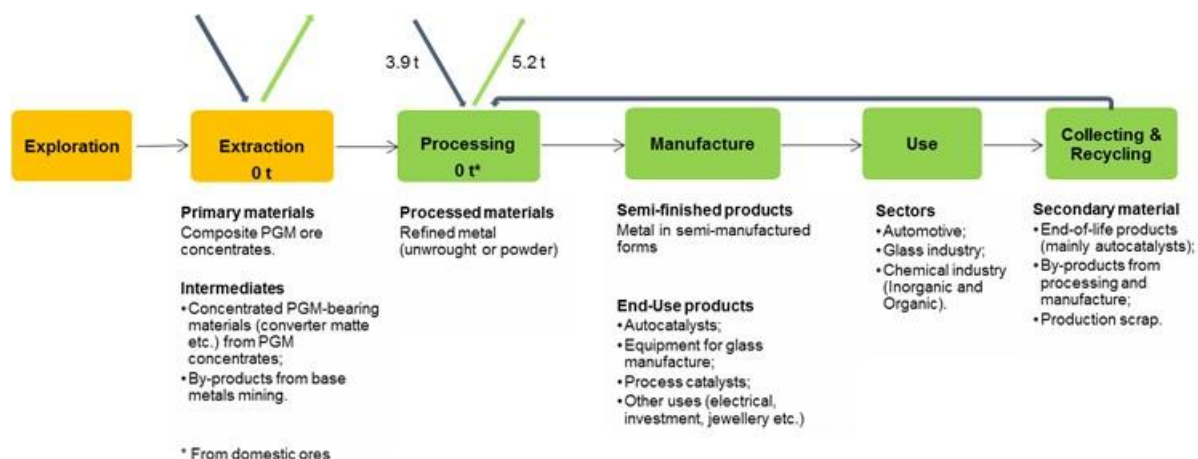
Its use in autocatalysts dominates demand for platinum. In 2018, consumption of platinum in autocatalysts accounted for 39% of global demand and 75% of European demand, reflecting the dominance of diesel vehicles in Europe in comparison with the rest of the world. Besides autocatalysts, other important applications of platinum include the use in jewellery, and as a catalyst in chemical manufacture such as nitric acid production. Palladium can be used instead of platinum in gasoline-engine catalysts with good performance, whereas for diesel engines some platinum may be substituted by palladium.

Platinum's resources and reserves are concentrated in southern Africa. The Great Dyke layered intrusion and the Bushveld Complex in South Africa are the two largest PGM deposits worldwide. Global reserves of platinum are estimated to 13 kt, with South Africa accounting for about 82%, Zimbabwe for 7%, and Russia for 6% of the total.

The average annual mine production worldwide is estimated at 178 tonnes for the period 2012-2016. South Africa is the dominant producer with a share of over 70% of the world mine production. Russia and Zimbabwe are other important producers with a share of 13% and 7%, respectively. EU mine production makes a small contribution to European platinum supply with an annual output of about one tonne, of which about 95% is produced in Finland and the remainder in Poland. The secondary supply of platinum is based on the recycling of spent autocatalysts and old jewellery.

). Platinum is a material of significance for fuel cells, a key technology for the transition to a low-carbon economy. Fuel cell electric vehicles are expected to play an important role in the achievement of a low-carbon road transport system, especially for heavy vehicles in long-distance transport. Fuel cell technology using platinum catalysts is also applicable for stationary applications to generate heat and power.

### 19.1.2.4 Overview of rhodium



**Figure 230: Simplified value chain for rhodium (average 2012-2016)**

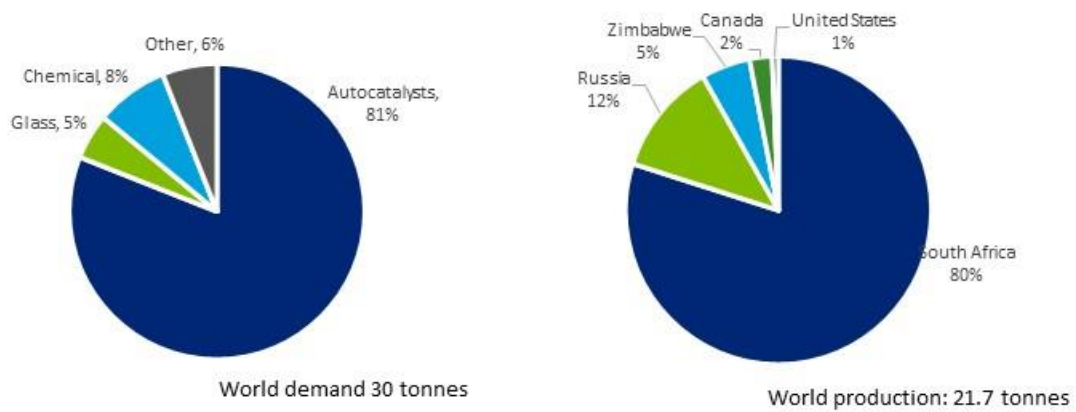
Rhodium (Rh, atomic number 45) is one of the six elements commonly referred to as the platinum group metals (PGM). The PGMs are, in order of increasing atomic number, ruthenium (Ru), rhodium (Rh), palladium (Pd), osmium (Os), iridium (Ir) and platinum (Pt). Rhodium is a silvery-white metal with excellent reflective properties. With a density of 12.41 g/cm<sup>3</sup>, it is lighter than platinum, iridium and osmium but has a higher melting point (1,960 °C) than platinum and palladium. Moreover, rhodium is harder (5.5 hardness on the Mohs scale) and less malleable than these; its hardness makes it an excellent alloying element to harden platinum and palladium. Rhodium is extremely corrosion resistant and does not tarnish in the air at room temperature. It has exceptional catalytic activity, similar to platinum and platinum, and outstanding electrical conductivity, the highest among PGMs. Rhodium is predominantly used as an alloy with other PGMs.

This specific factsheet is complementary to the general PGM factsheet presenting additional information and data specific to rhodium where available.

The trade code HS 711031 “Rhodium, unwrought or in powder form” was used in the assessment.

Rhodium is the third most commercially important of the PGMs, behind platinum and palladium. The market supply is highly concentrated as South Africa holds an 80% share of the world mine output. South Africa and the UK are the leading world exporters for rhodium unwrought or in powder form. In the short-term growth in global vehicle usage and the imposition of increasingly strict emission control legislation across the world is likely to continue to increase demand for rhodium in autocatalysts. In the mid- to longer-term, the transition to electric mobility may lead to reduced demand for rhodium.

Since October 2016, the rhodium price has been rising steadily, and in September 2019 peaked to a multi-year high of USD 5,000 per oz. The significant gains in the rhodium price in 2019 coincide with projected increased demand for autocatalysts due to tighter emissions legislation and more stringent testing.



**Figure 231: Global end uses of rhodium (average 2012-2016), and estimated world mine production (average 2012-2016).**

The annual global demand for rhodium was 30 tonnes as an average in years 2012-2016. The import reliance for rhodium originating from primary sources is 100%. Nevertheless, the EU is an important global supplier of refined rhodium metal produced from secondary materials, collected domestically or imported, and, therefore, the actual net import reliance is lower.

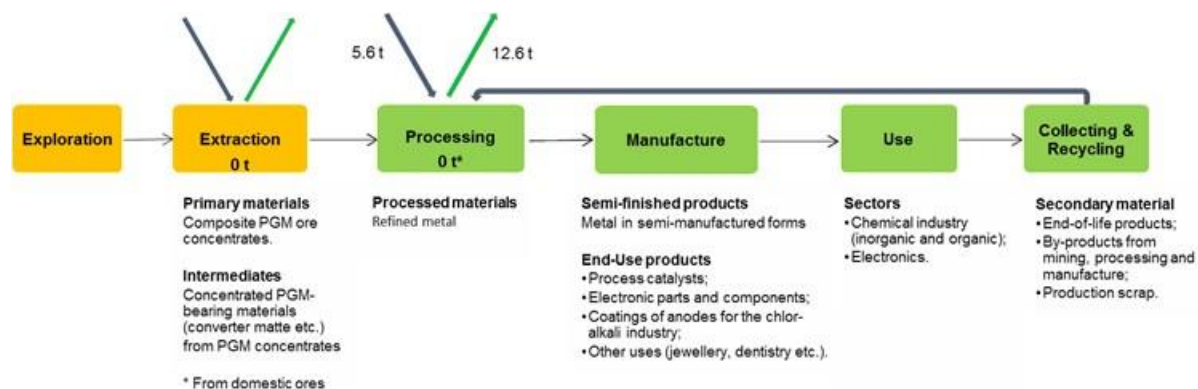
Rhodium is used predominantly in autocatalysts which account for over 80% of global demand. Rhodium is also essential in the manufacture of glass and specific process catalysts for the chemicals sector (e.g. nitric acid production). Cobalt is a potential substitute in process catalysts for aldehydes production, ruthenium in catalysts for acetic acid production, and gold or iridium in glass manufacturing equipment.

The world's largest PGM mineral resources with rhodium occurrences reside in South Africa. Rhodium also occurs in notable PGM deposits in Russia and Zimbabwe.

The world rhodium mine production is estimated at 22 tonnes annually. The sheer dominance of South Africa in the primary world supply of rhodium is emphasised by its share of 80% of the world total, followed by Russia (12%) and Zimbabwe (5%), averaged for the period 2012-2016. Rhodium is produced as co-product from platinum group-metal mining operations. There is no production of rhodium from primary sources in the EU. Though, rhodium is almost entirely recycled from spent automotive catalysts, which contributes a substantial proportion of the total metal supply, a relatively higher share than for platinum and palladium. The global average end-of-life functional recycling rate ranges from 50% to 60%. In 2018, recycling accounted for 31% of rhodium global supply.

Rhodium is not assessed as a key material for the transition to net-zero greenhouse gas economy. One application in low-carbon technologies identified for rhodium is the production of fibreglass for wind turbines and automotive lightweight, as rhodium is used in platinum alloys for glass-making equipment.

### 19.1.2.5 Overview of ruthenium



**Figure 232: Simplified value chain for ruthenium (average 2012-2016)**

Ruthenium (Ru, atomic number 44) is one of the six platinum-group metals (PGM). The PGM consists of the following elements in order of increasing atomic number: ruthenium (Ru), rhodium (Rh), palladium (Pd), osmium (Os), iridium (Ir) and platinum (Pt). Ruthenium is the fourth of the PGM in order of commercial significance, after platinum, palladium and rhodium; however, its demand is comparable with that of rhodium in terms of quantity. Ruthenium is a shiny silver-grey metal, considerably lighter than platinum, osmium and iridium with a density of 12.45 g/cm<sup>3</sup>. It has a very high melting point of 2,310 °C, and is exceptionally hard (hardness of 6.5 on the Mohs scale), over five times harder than platinum, as well as brittle, even after annealing at temperatures as high as 1,500 °C; therefore, the use of pure ruthenium is restricted because it is extremely difficult to work. Ruthenium is generally used as an alloying agent to platinum and palladium to improve wear resistance in electrical contacts and to impart hardness in certain jewellery alloys. Also, on account of its exceptional corrosion resistance, very good electrical and catalytic properties, ruthenium finds essential applications in the electronics and chemical industries.

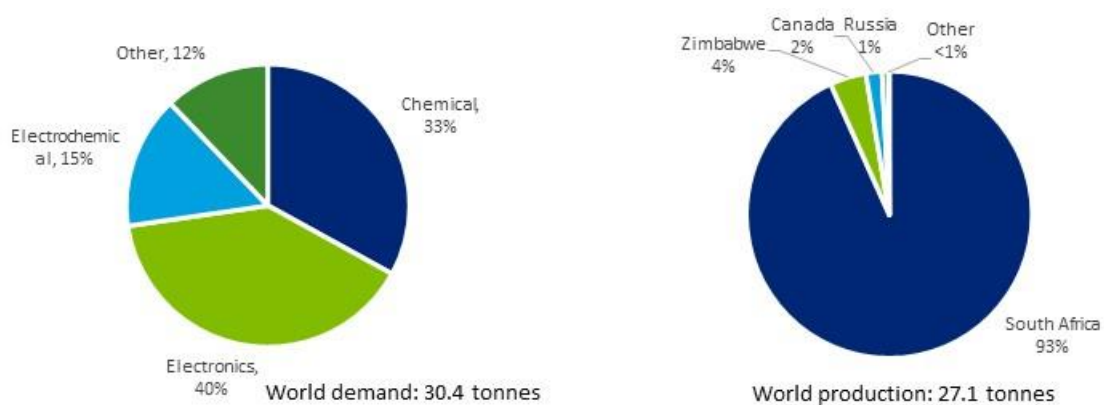
This factsheet is complementary to the general PGM factsheet presenting additional information and data specific to ruthenium where available.

The trade code used in the assessment is HS 711041 "Iridium, osmium & ruthenium, unwrought or in powder form". The relative proportion of ruthenium and iridium in this total trade flow was calculated under the assumption of being proportional to their average market size in the period 2012-2016.

Ruthenium, as iridium, is of lower commercial importance compared to platinum, palladium, and rhodium. Global supply is highly concentrated in terms of both mine production and secondary recovery. The top importer worldwide of the "minor PGMs" (iridium, ruthenium, and osmium) in unwrought and powder form is Japan, and in semi-manufactured forms the US and China. As concerns the leading exporting countries, for unwrought metal and powder is South Africa and Germany, and for semi-manufactured forms the UK and South Africa.

The market for ruthenium is small and illiquid and subject to high price volatility. In 2018, the price of ruthenium climbed to a ten-year high of USD 270 per troy ounce.





**Figure 233: Global end uses of ruthenium (average 2012-2016), and estimated world mine production (average 2012-2016).**

The annual global demand for ruthenium was 30.4 tonnes as an average in years 2012-2016. The import reliance for ruthenium originating from primary sources is 100%. Nevertheless, the EU is an important global supplier of refined ruthenium metal originating from secondary materials collected domestically or imported, and, therefore, the actual net import reliance is lower. In the period 2012-2016, South Africa and the UK were the main source countries for EU imports of ruthenium in unwrought or powder form by similar shares of nearly 40% each.

Currently, the primary use of ruthenium worldwide is for electronic applications, with process catalysts and electrochemical applications in the chemical industry for the manufacture of organic and inorganic chemicals the next most important. In particular, ruthenium is mainly used in anodes for the electrochemical production of chlorine and caustic soda, electrical contacts for thermostats and relays, hard disk drives, and as a catalyst in oil refining and chemical industry (e.g. ammonia synthesis). Potential substitution materials for electrical applications are other PGM (mostly palladium) and silver, and an iron-based alloy for ammonia synthesis.

South Africa hosts the majority of PGM resources with identified ruthenium occurrences. Ruthenium also occurs in PGM deposits in Zimbabwe and Russia. Data on resources and reserves for ruthenium are not available in the public domain.

The average annual mine production worldwide is estimated at about 27 tonnes for the period 2012-2016. South Africa is by far the leading producer with a share of over 90% of the world mine production where ruthenium originates as co-product from platinum group-metal mining operations. Small quantities are extracted in mines in Zimbabwe, Canada and Russia. There is no production of ruthenium in the EU from primary sources. The end-of-life recycling input rate of ruthenium is estimated at 11%. Ruthenium is mostly recovered from process catalysts.

A contribution of ruthenium for the transition to a climate-neutral economy is recognised in platinum catalysts for fuel cell technology.

## **19.2 Market analysis, trade and prices**

---

### **19.2.1 Global market of platinum group metals in general**

PGM mine production is highly concentrated in a few countries. The producing countries of PGMs are South Africa, Russia, Zimbabwe, Canada, and the United States, which account for 99% of global production. South Africa is the leading producer, with a share of about 58% of world PGM mine production in 2017. According to the British Geological Survey (BGS, 2019), the annual mine production of PGMs in 2017 was 446 tonnes, while in 2018 the annual mine production of platinum-palladium-rhodium was 412 tonnes according to Johnson Matthey (2019a). The value of PGM production at average annual prices of 2018 was US\$14.8 billion, of which US\$5.4 billion for platinum, US\$7.2 billion for palladium, US\$ 2.3 billion for rhodium, and US\$0.5 billion for ruthenium and iridium (Hagelüken, 2019).

In addition to the high geographical concentration of mines, global mine production of PGMs is also dominated by few companies. The top four PGM producers are Anglo American Platinum, Norilsk Nickel, Impala Platinum, and Sibanye Stillwater. They accounted for approximately 87% of the market in 2018 (IPA Industrial expert, 2019), and maintain considerable processing assets that supply the market with refined PGMs and by-products of the PGM production (Ndlovu, 2015). A significant market player emerged in the last years is the South African company Sibanye Gold, which initially bought the Rustenburg mines in 2016 from Anglo American Platinum, and in May 2017 purchased the US Stillwater Mining Co; in June 2019, Sibanye-Stillwater was merged with Lonmin. This company currently controls 20% of the world's PGM primary production (Hagelüken, 2019), and has become the world's largest PGM producer (PWC, 2019).

In general, the PGM mining sector is vertically integrated, from mining through concentration to smelting, refining and marketing of the PGM (Hagelüken, 2019). Exceptions do exist, for example, Norilsk Nickel's metal is refined by third parties in Russia, whereas in South Africa only a part of Lonmin operations (now Sibanye-Stillwater) are integrated through to refined metal, while the remainder is refined and sold by other companies (IPA Industrial expert, 2019). Four companies dominate PGM mining in South Africa: Anglo-American Platinum, Impala Platinum, Sibanye Stillwater and Northam Platinum. Each of these runs integrated operations in South Africa, and/or has agreements with other refiners to process their metal in South Africa. About 25% of the processing of the extracted ores, from concentration to refining, was carried out by non-integrated miners (Ndlovu, 2015).

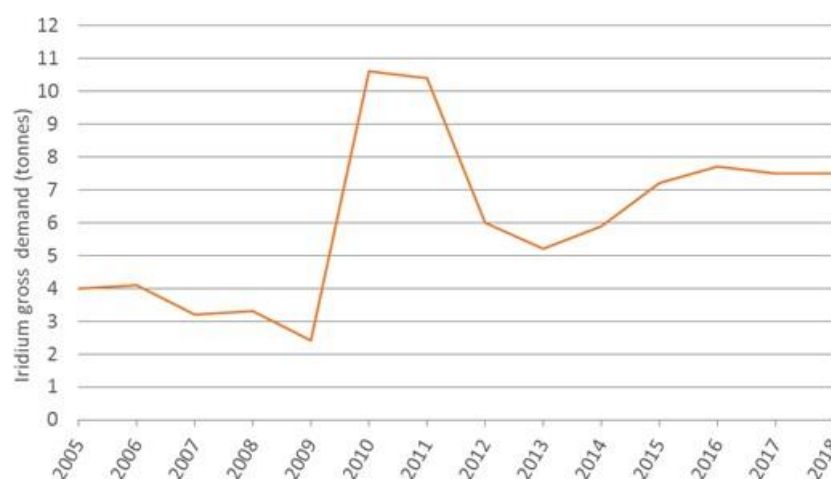
The PGM value chain is also highly concentrated in the manufacturing stage. The global PGM fabrication sector is dominated by five companies (Johnson Matthey, BASF, Umicore, Heraeus and Tanaka) that account for approximately 85% of the market of fabricated products (Ndlovu, 2015). Four of these have a strong presence in Europe. These companies run large integrated operations that derive their supplies from a combination of primary and secondary sources. They deliver a diverse range of PGM-bearing materials and products to the global market from specialised plants located in different parts of the world, including Europe (European Commission, 2017a).

Almost all PGMs derived from primary source materials (i.e. mine production) is traded in the form of refined metal produced from integrated mining/metallurgical operations. There is only minimal international trade in PGM ores and concentrates (European Commission, 2017a).

## 19.2.2 Global market of individual platinum group metals

### 19.2.2.1 Global market of iridium

The demand for iridium is considerably lower than for the other PGMs, with the exception of osmium. In 2018, the annual global gross demand for iridium was 7.5 tonnes, increased by nearly 88% in comparison to 2005, with significant fluctuations. Over the 2016 to 2018 period, demand for iridium exceeded mine output, but sales from producer stocks have kept the markets supplied (Johnson Matthey, 2019a). South Africa is the dominant world producer of iridium from primary sources. The market value of iridium metal consumed in 2018 is estimated at USD 0.28 billion<sup>180</sup>.



**Figure 234: Global gross demand<sup>181</sup> for iridium from 2005 to 2018 (background data from (Johnson Matthey, 2019a) for 2014-2018, (Johnson Matthey, 2018) for 2013, (Johnson Matthey, 2014) for 2005-2012**

Iridium has a very small and illiquid market, and the global primary supply is highly concentrated; thus, modest increases in demand or fluctuations in supply can have a significant impact on availability (Johnson Matthey, 2018). In addition, given that iridium is effectively a by-product of platinum and/or palladium extraction, its supply is closely linked to the production of the host PGM (European Commission, 2017). Furthermore, only few market participants have the capability to refine iridium from secondary sources fully, and lead times for refining are typically very long, often over 20 weeks, which may cause disruptions in the supply chain (Johnson Matthey, 2019a).

Over the 2016 to 2018 period, demand for iridium exceeded mine output, but sales from producer stocks have helped to keep the markets supplied. According to Johnson Matthey market analysis, strategic purchasing in Asia contributed to unusually large amounts of iridium shipped in 2016–2017 (Johnson Matthey, 2019a).

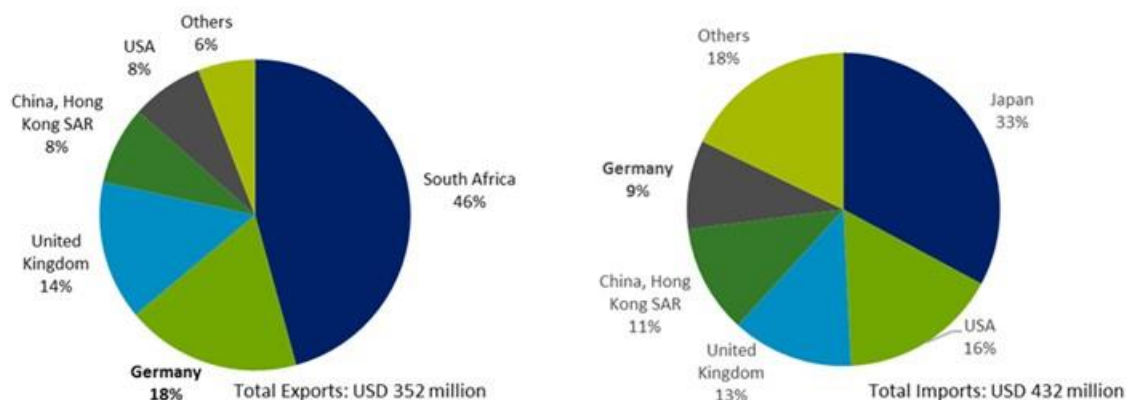
Almost all iridium derived from primary source materials (i.e. mine production) is traded in the form of refined products from integrated mining/metallurgical operations. There is only minimal international trade in iridium ores and concentrates (European Commission, 2017).

The Harmonised System does not separate trade flows for iridium and trade data are available only under the single HS code 711041, which consist of "iridium, osmium and ruthenium metal in unwrought or powder form". South Africa is the leading world supplier

<sup>180</sup> Estimated as: 219,000 oz of global gross demand in 2018 X 1,284 USD/oz average price in 2018

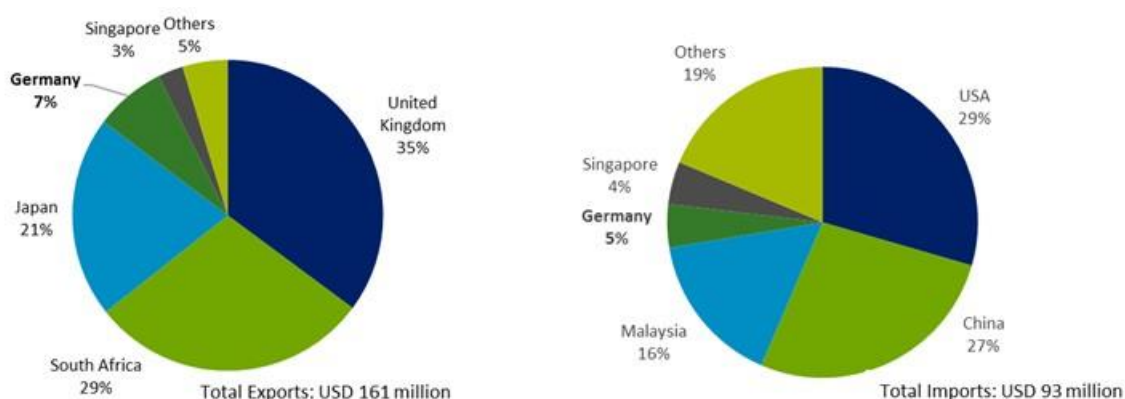
<sup>181</sup> Gross demand is the sum of manufacturer demand for metal in that application and any changes in unrefined metal stocks.

of ruthenium-iridium-osmium metal. In 2017, exports from South Africa accounted for 46% of international trade value of ruthenium+iridium+osmium metal. Germany and the United Kingdom are also significant exporters with a share of 18% and 14% respectively of the value of global exports in 2017. Japan is the top importer of these three PGMs with 33% of global imports by value in 2017. The United States and the United Kingdom are also important destination countries for ruthenium+iridium+osmium metal representing 16% and 13% respectively of global imports by value.



**Figure 235: Top-5 iridium, osmium & ruthenium (unwrought/in powder form, HS 7110 41) exporting (left) and importing (right) countries in 2017 by value. Data from (UN Comtrade, 2019).**

The Harmonised System does not separate either trade flows for downstream iridium semi-finished products. Trade data are available only under the single HS code 7110 49, which comprises "iridium, osmium and ruthenium metal in semi-manufactured forms". The UK is the top world supplier of ruthenium-iridium-osmium in semi-manufactured forms with exports accounting for 35% of the total exports value in 2017. South Africa (29%) and Japan (21%) are also important exporters worldwide. The United States and China are the top destination countries for ruthenium+iridium+osmium in semi-manufactured forms accounting for 29% and 27% respectively of global imports by value in 2017. Malaysia is also a significant importer of semi-manufactured forms of these three PGM, with a share of 16% of global imports by value in 2017.



**Figure 236: Top-5 iridium, osmium & ruthenium (in semi-manufactured forms, HS 7110 49) exporting (left) and importing (right) countries in 2017 by value. Data from (UN Comtrade, 2019).**

Concerning export taxes, quotas or export prohibition in place in 2017, Zimbabwe applied a 15% tax for HS 7110 41 "Iridium, osmium & ruthenium, unwrought or in powder form"

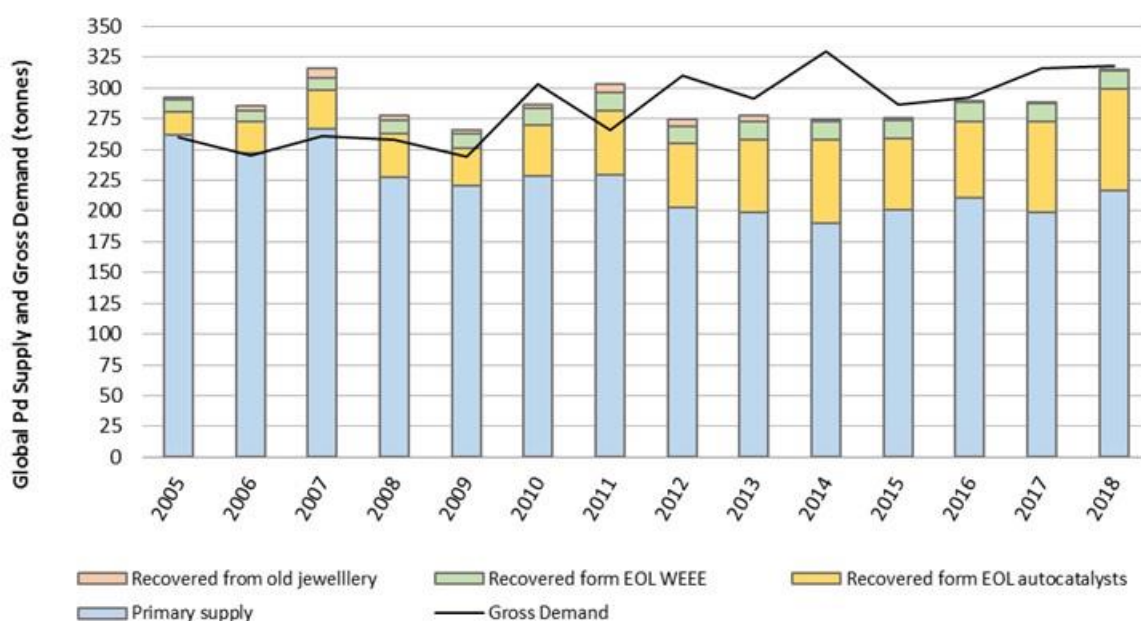
and HS 7110 49 "Iridium, osmium & ruthenium, in semi-manufactured forms". Russia imposed an export tax of 6.5% for both codes until 31/8/2016 (OECD, 2019).

### 19.2.2.2 Global market of palladium

Palladium and platinum, are the most commercially important of the PGM with the most extensive range of applications.

The world mine production of palladium amounted to 217 tonnes in 2018. Russia and South Africa dominate the world supply of palladium from primary sources, with a combined share of 79% of the world mine production in 2018 (Johnson Matthey, 2019a), which highlights the market concentration. Palladium's global supply increased sharply from 1994 to 2001 following the explosion of demand, and Russian exports almost entirely drove this rise. This temporary expansion in supply was achieved mainly through significant sales from Russian state stocks (Hagelüken, 2019). The Russian production is derived almost exclusively from the underground mines extracting nickel sulphide ores in the Norilsk-Talnakh district. The output in Norilsk peaked in 2006 at 100 tonnes per year. Since then, it has fluctuated in a range of 75-90 tonnes per year, whereas sales from Russian state stocks have come to an end in 2013 (Hagelüken, 2019; Johnson Matthey, 2014; Johnson Matthey, 2019a).

Figure 237 below presents the evolution in the supply and demand of palladium from 2005 to 2018. Palladium's market is in deficit since 2011, and this reflected in poor liquidity and higher prices (Johnson Matthey, 2017; Johnson Matthey, 2018).



**Figure 237: Global supply and demand of palladium from 2005 to 2018. Background data for 2014-2018 in (Johnson Matthey, 2019a), for 2013 in (Johnson Matthey, 2018), and for 2005-2012 in (Johnson Matthey, 2014)**

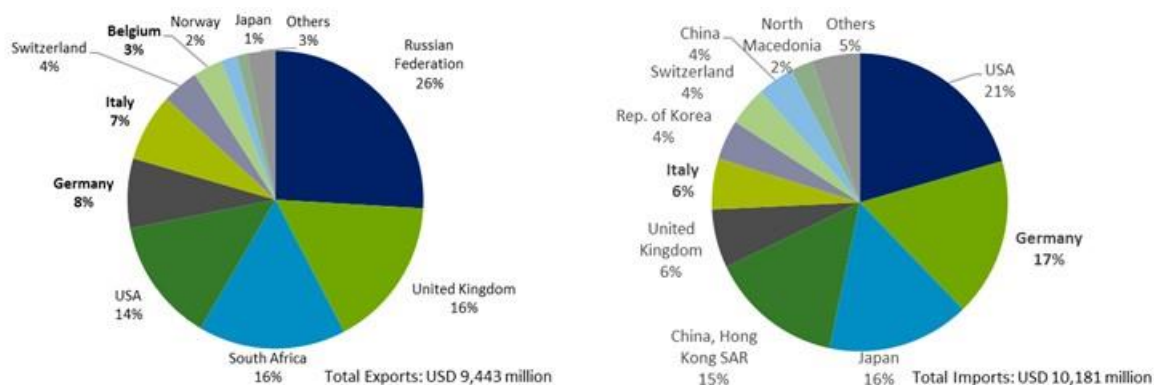
The market value of the consumed palladium metal is estimated at €8.9 billion<sup>182</sup> for the year 2018.

Almost all palladium derived from primary source materials (i.e. mine production) is traded in the form of refined products from integrated mining/metallurgical operations. There is

<sup>182</sup> Estimated as: 10,220,000 oz of global gross demand in 2018 X 874 EUR/oz average price in 2018

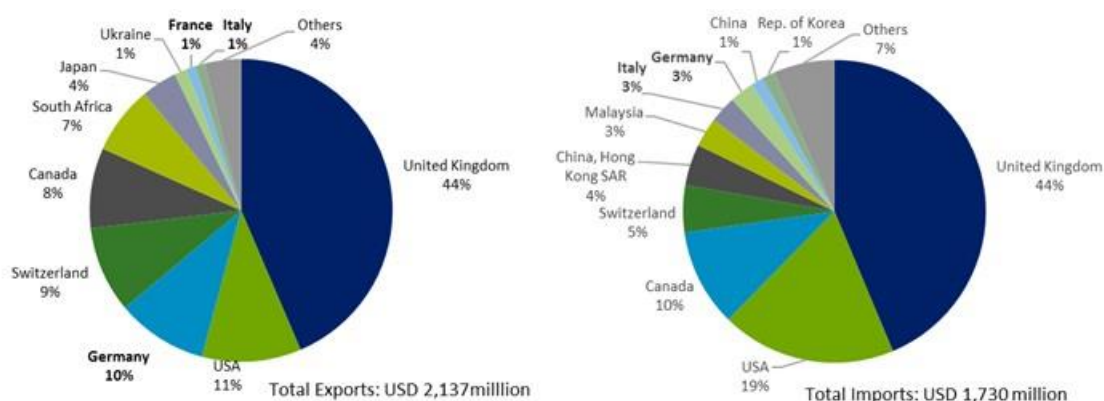
only minimal international trade in palladium ores and concentrates (European Commission, 2017).

Russia is the most significant world supplier of palladium metal in unwrought or in powder form. Exports from Russia accounted for 26% of international trade of palladium metal in unwrought or in powder form by value in 2017 (see Figure 238). The United Kingdom and South Africa are also important exporters with a share of 16% each of global exports by value in 2017. The United States is the leading importer of accounting for 21% of global imports by value in 2017. Germany and Japan are also significant destination countries for palladium in unwrought or in powder form with a share of 17% and 16%, respectively, of global imports by value.



**Figure 238: Top-10 palladium (unwrought/in powder form, HS 7110 21) exporting (left) and importing (right) countries in 2017 by value. Data from (UN Comtrade, 2019).**

The UK is the most significant market player in the international trade of palladium in semi-manufactured forms, with 44% share for both total imports value and total exports value in 2017 (see Figure 239). Along with the United Kingdom, the United States (11%), Germany (10%), Switzerland (9%) and Canada (8%) are the top-5 exporters of palladium in semi-manufactured forms worldwide. The United States (19%) and Canada (10%) are the most important importers, apart from the United Kingdom, of palladium in semi-manufactured forms.



**Figure 239: Top-10 palladium (in semi-manufactured forms, HS 7110 29) exporting (left) and importing (right) countries in 2017 by value. Data from (UN Comtrade, 2019)**

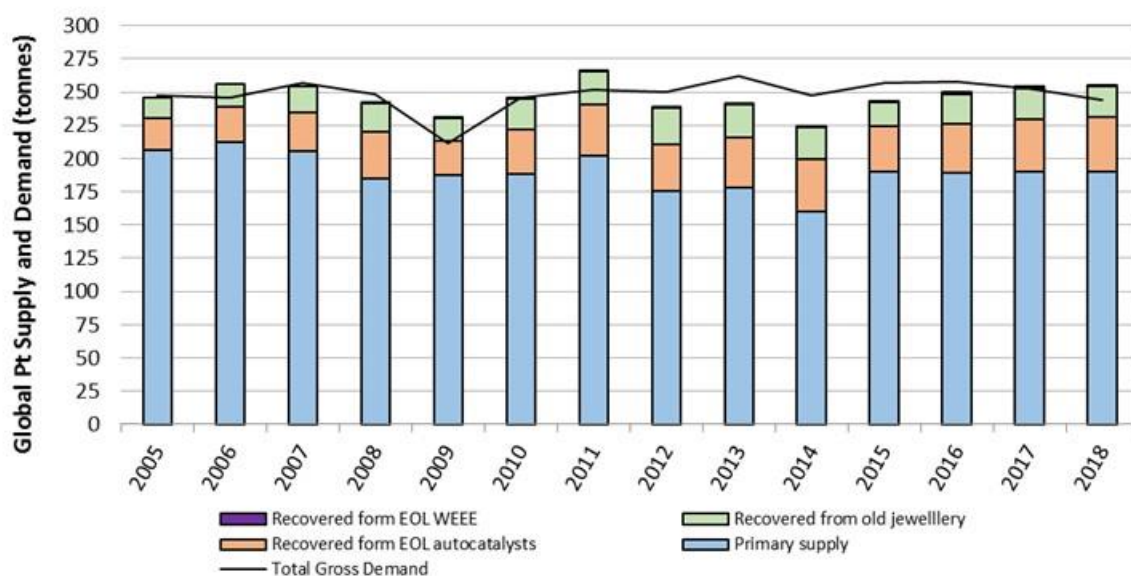
Regarding the most relevant export restrictions (export taxes, quotas or export prohibition) in place in 2017, Zimbabwe applied a 15% tax for HS 7210 11 "Palladium, unwrought/in powder form" and HS 7110 19 "Palladium, in semi-manufactured forms". According to the OECD inventory of export restrictions, the effect of an export tax (6.5%) imposed by Russia for both trade codes ended on 31/8/2016 (OECD, 2019).

### 19.2.2.3 Global market of platinum

Platinum and palladium are of major commercial significance, having the broadest range of applications of the PGM.

The world mine production in 2018 was 190 tonnes. South Africa accounted for about 73% of the total mine production, dominating the primary supply of platinum (Johnson Matthey, 2019b). South Africa's production comes from several mines, most of them underground, at the Bushveld Igneous Complex. As refining of PGMs mined in Zimbabwe is carried out in South Africa (Hagelüken, 2019), more than 80% of the global platinum supply from primary sources is controlled by South Africa.

Figure 240 shows the development of platinum supply and demand since 2005. Global platinum production from mines reached a peak in 2006 at the level of 212 tonnes driven by a significant production increase from South Africa. The platinum production increased by about 40% from 120 tonnes in 2000 to 165 tonnes in 2006. Since then, South African production has been on a downward trend and has stabilised at levels of around 140 tonnes per year in the period 2015-2018. The reasons for the decline have been problems in energy supply, difficult mining conditions, and disruptions from events such as strikes and social unrest (Hagelüken, 2019). In relation to demand, the overall platinum demand is relatively stable fluctuating approximately between 245 and 260 tonnes per year, except 2008 as a result of the financial crisis. The platinum market has been in a surplus in 2017 and 2018 after five consecutive years of deficit.



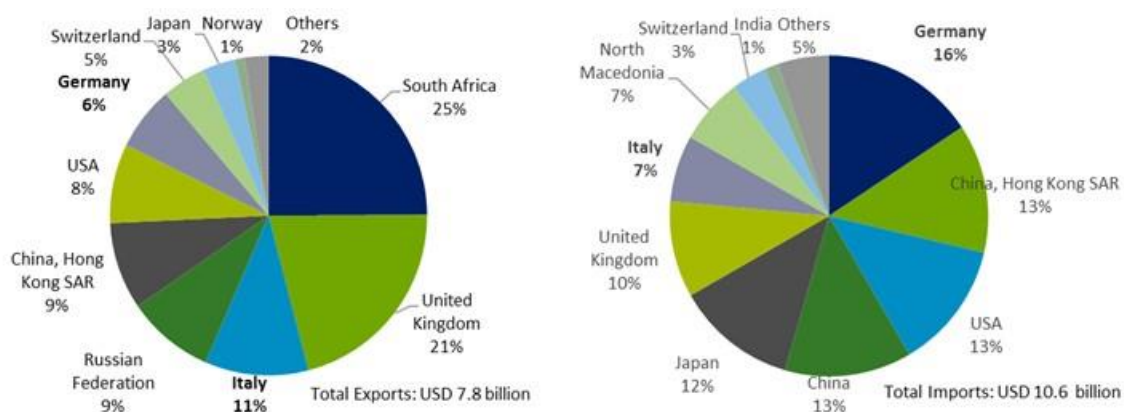
**Figure 240: Global supply and demand of platinum from 2005 to 2018. Background data for 2014-2018 in (Johnson Matthey, 2019b), for 2013 in (Johnson Matthey, 2018), and for 2005-2012 in (Johnson Matthey, 2014).**

The market value of platinum metal consumed in 2018 is estimated at €5.8 billion<sup>183</sup>.

<sup>183</sup> Estimated as: 7,846,000 oz of global gross demand in 2018 X 744 €/oz average price in 2018

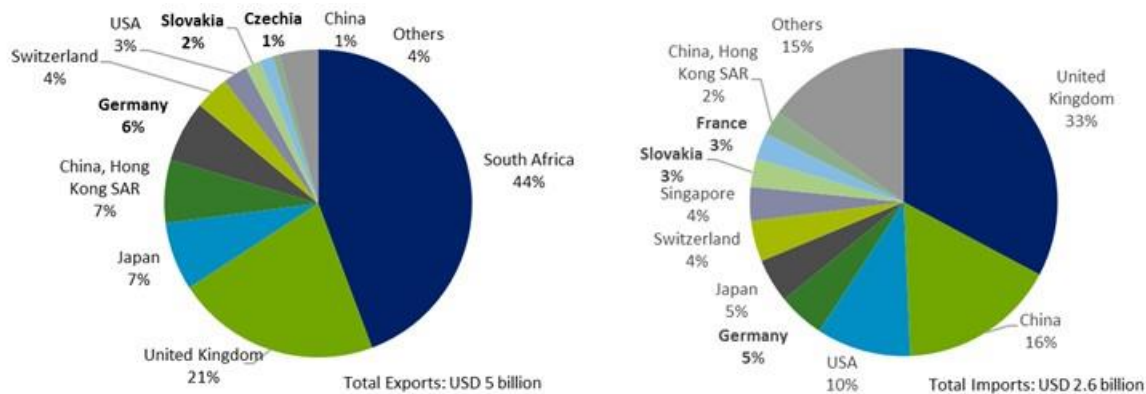
Almost all platinum derived from primary source materials (i.e. mine production) is traded in the form of refined products from integrated mining/metallurgical operations. There is only minimal international trade in platinum ores and concentrates (European Commission, 2017).

In 2017, South Africa and the United Kingdom were the main sources worldwide for imports of platinum in unwrought or in powder form, accounting for 25% and 21% respectively of the world's total exports by value (Figure 241). Italy is the third-ranked world exporter with a share of 11%.



**Figure 241: Top-10 platinum (in unwrought/powder form, HS 7110 11) exporting (left) and importing (right) countries in 2017 by value. Data from (UN Comtrade, 2019).**

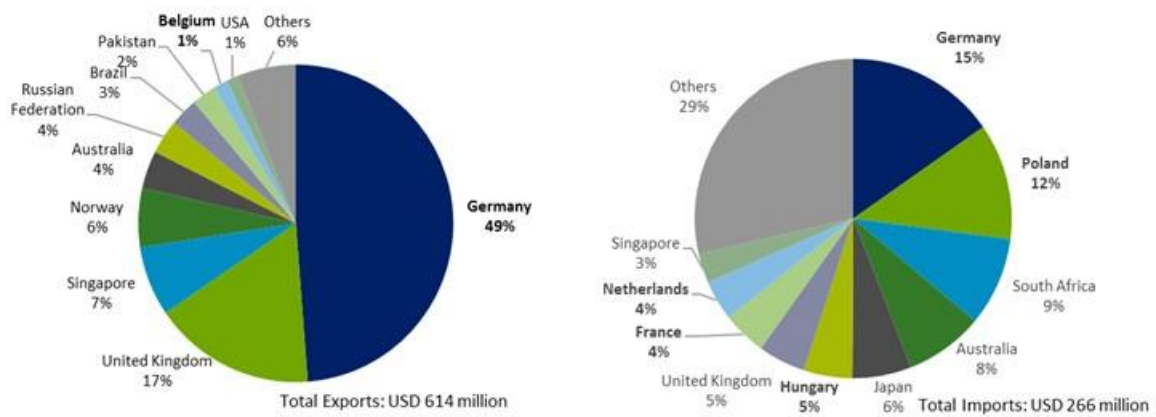
South Africa and the United Kingdom are also the main sources of world's exports of platinum in semi-manufactured forms, accounting for about the two-thirds of global exports by value (see Figure 242). The main destination countries for the world trade of platinum in semi-manufactured forms are the United Kingdom and China, accounting for 33% and 16% of the world imports by value, respectively.



**Figure 242: Top-10 platinum (in semi-manufactured forms, HS 7110 19) exporting (left) and importing (right) countries in 2017 by value. Data from (UN Comtrade, 2019)**

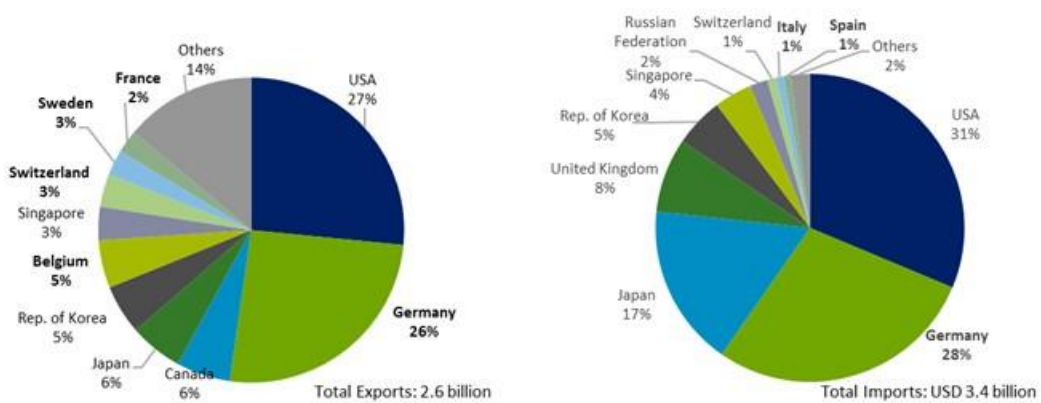
As regards platinum catalysts (in the form of wire cloth or grill), Germany provided almost half of world's imports, while a group of EU MS are among the top-10 export destinations of platinum catalysts (see Figure 243).





**Figure 243: Top-10 platinum catalysts (in the form of wire cloth or grill, HS 7115 10) importing (left) and exporting (right) countries in 2017 by value. Data from (UN Comtrade, 2019)**

Moreover, there is significant international trade of platinum-bearing waste and scrap in the EU Member States. Figure 244 shows the top importers and exporters worldwide of waste and scrap of platinum by value. The US and Germany dominate the international trade of platinum waste and scrap.



**Figure 244: Top-10 platinum (Waste & scrap of platinum, HS 7112 92) exporting (left) and importing (right) countries in 2017 by value. Data from (UN Comtrade, 2019)**

Concerning the export taxes, quotas or export prohibition in place in 2017, Zimbabwe applied a 15% tax for HS 7110 11 "Platinum, unwrought/in powder form" and HS "7110 19 Platinum, in semi-manufactured forms". According to the OECD inventory of export restrictions, the effect of an export tax (6.5%) imposed by Russia for both trade codes ended on 31/8/2016 (OECD, 2019).

#### 19.2.2.4 Global market of rhodium

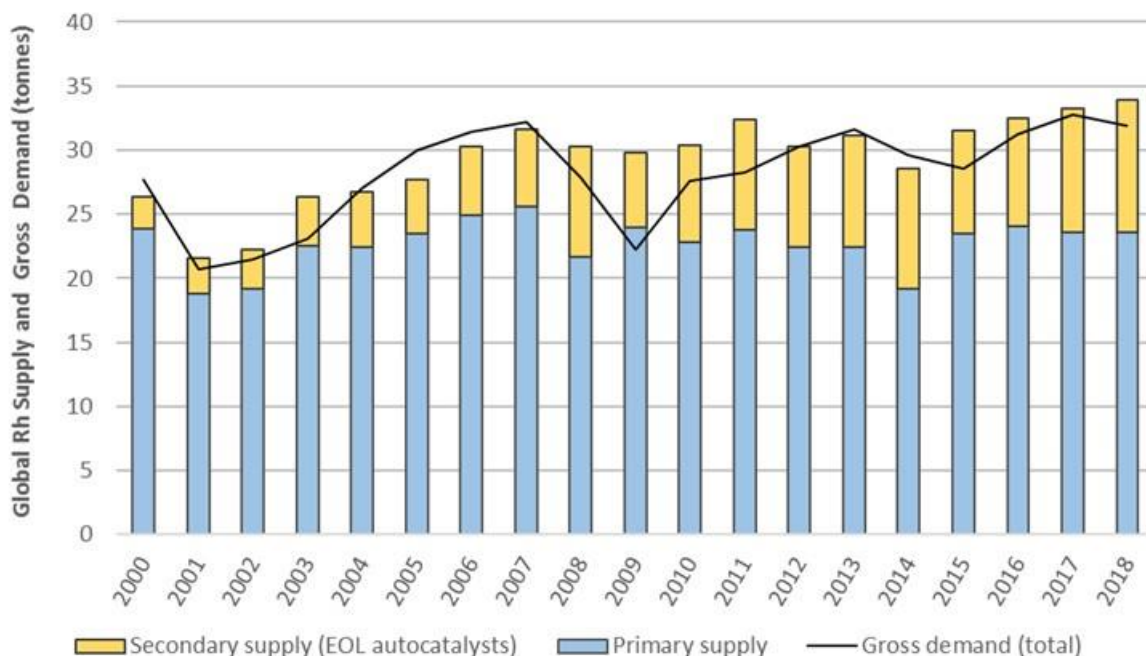
After platinum and palladium, rhodium is the third most important in commercial significance among the PGMs. The world mine supply of rhodium is geographically highly concentrated. Global mine production is dominated by South Africa, with a share of 81% in 2017 (WMD, 2019). Other market players in mine supply are Russia (11%), Zimbabwe (6%) and Canada (3%).

Over the 2015 to 2018 period, rhodium's gross global annual demand ranged from 28.6 tonnes to 32.7 tonnes. In the same period, supply for primary and secondary sources

exceeded demand. Gross rhodium demand reached a record of 32.7 tonnes in 2017, almost precisely matching combined primary and secondary quantities, and leaving the market in balance.

The market value of rhodium metal consumed in 2018 is estimated at US\$2.3 billion<sup>184</sup>.

Figure 245 below presents the evolution in the supply and demand of rhodium from 2005 to 2018. The rhodium market has been in surplus since 2015.



**Figure 245: Global supply and gross demand<sup>185</sup> of rhodium from 2000 to 2018 (background data from (Johnson Matthey, 2019a) for 2014-2018, (Johnson Matthey, 2018) for 2013, and (Johnson Matthey, 2014) for 2000-2012).**

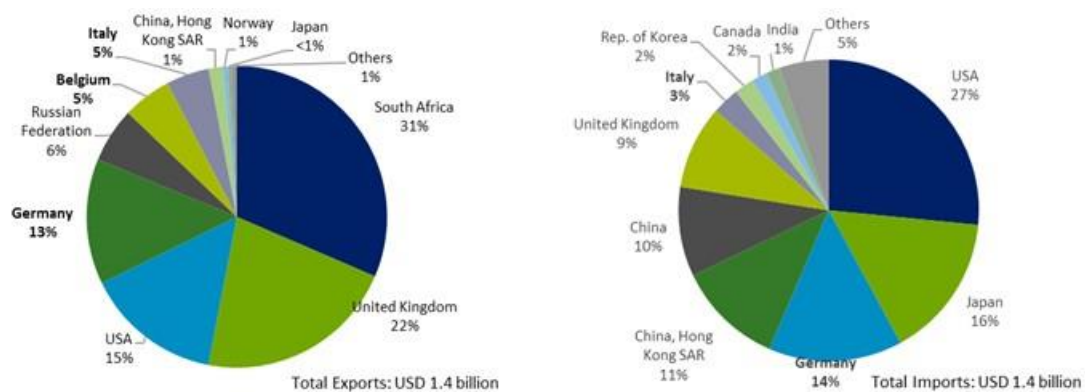
The rhodium market is small and illiquid, and the global primary supply highly concentrated. Therefore, modest increases in demand or fluctuations in supply can have a significant impact on prices and physical availability (Johnson Matthey, 2018). Moreover, given that rhodium is effectively a by-product of platinum and palladium extraction, its supply is closely tied to the production of those PGMs (European Commission, 2017). Finally, the market availability of rhodium metal may be restricted in the short-term by capacity constraints in the secondary refining sector (Johnson Matthey, 2019a).

Almost all rhodium derived from primary source materials (i.e. mine production) is traded in the form of refined products from integrated mining/metallurgical operations. Hence, there is only minimal international trade in rhodium ores and concentrates (European Commission, 2017).

Figure 246 presents the top world importers and exporters by value in 2017 of rhodium metal in unwrought or in powder form (HS 7110 31). South Africa is the most significant exporter (31%) followed by the UK (22%), the US (15%) and Germany (13%). The US is the largest importer (27%), followed by Japan (16%), and Germany (14%).

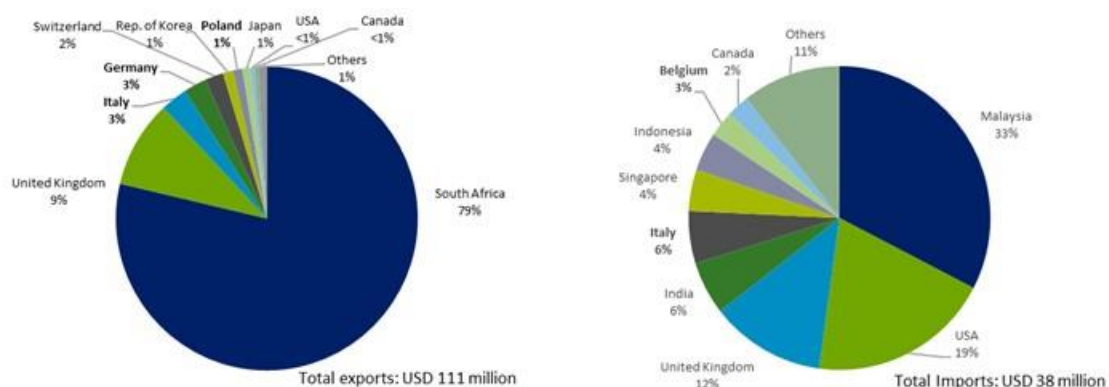
<sup>184</sup> Estimated as: 1,026,000 oz of global gross demand in 2018 X 2,220 US\$/oz average price in 2018

<sup>185</sup> Gross demand is the sum of manufacturer demand for metal in that application and any changes in unrefined metal stocks.



**Figure 246: Top-10 rhodium (unwrought/in powder form, HS 7110 31) exporting (left) and importing (right) countries in 2017 by value. Data from (UN Comtrade, 2019).**

For rhodium in semi-manufactured forms (HS 7110 39), South Africa is the top supplier worldwide accounting for 79% of world exports by value in 2017, followed by the UK (9%). Malaysia is the top destination country of international trade, with a share of 33% of global imports value in 2017, followed by the United States (19%) and the United Kingdom (12%). Figure 247 shows the top world importers and exporters of rhodium in semi-manufactured forms based on trade data for code HS 7110 39.



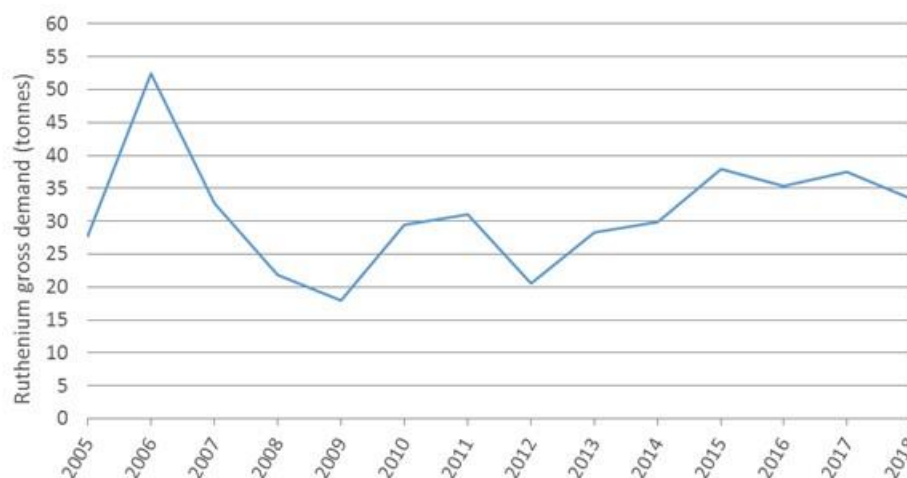
**Figure 247: Top-10 rhodium (in semi-manufactured forms, HS 7110 39) importing (left) and exporting (right) countries in 2017 by value. Data from (UN Comtrade, 2019)**

Regarding relevant export restrictions (export taxes, quotas or export prohibition) in place in 2017, Zimbabwe applied a 15% tax for HS 7210 31 "Rhodium, unwrought/in powder form" and HS 7110 39 "Rhodium, in semi-manufactured forms". The effect of an export tax (6.5%) imposed by Russia for both trade codes ended on 31/8/2016 (OECD, 2019).

#### 19.2.2.5 Global market of ruthenium

Ruthenium is the fourth of the PGM in order of commercial significance, after platinum, palladium and rhodium. South Africa dominates the supply from primary sources. On the demand side, the global gross demand for ruthenium is relatively stable in the last years (2015-2018), ranging from 33.5 tonnes to 38 tonnes. Ruthenium's demand is comparable with that of rhodium in terms of quantity. Over the 2016-2018 period, demand for ruthenium exceeded mine output, but sales from producer stocks have kept the markets

supplied (Johnson Matthey, 2019a). In 2018, the market value of the consumed ruthenium metal is estimated at USD 0.26 billion<sup>186</sup>.



**Figure 248: Global gross demand<sup>187</sup> for ruthenium from 2005 to 2018 (background data from (Johnson Matthey, 2019a) for 2014-2018, (Johnson Matthey, 2018) for 2013, (Johnson Matthey, 2014) for 2005-2012**

The market for ruthenium is small and illiquid, and the global primary supply highly concentrated. As a result, modest increases in demand or fluctuations in supply can have a significant impact on availability (Johnson Matthey, 2018). In addition, given that ruthenium is effectively a by-product of platinum and/or palladium extraction, its supply is closely tied to the production of the those PGM (European Commission, 2017). Furthermore, few market participants have the capability to refine ruthenium from secondary sources fully, and lead times for refining are typically very long, often over 20 weeks. Thus, the lengthy refining process which may cause bottlenecks in the supply chain (Johnson Matthey, 2019a).

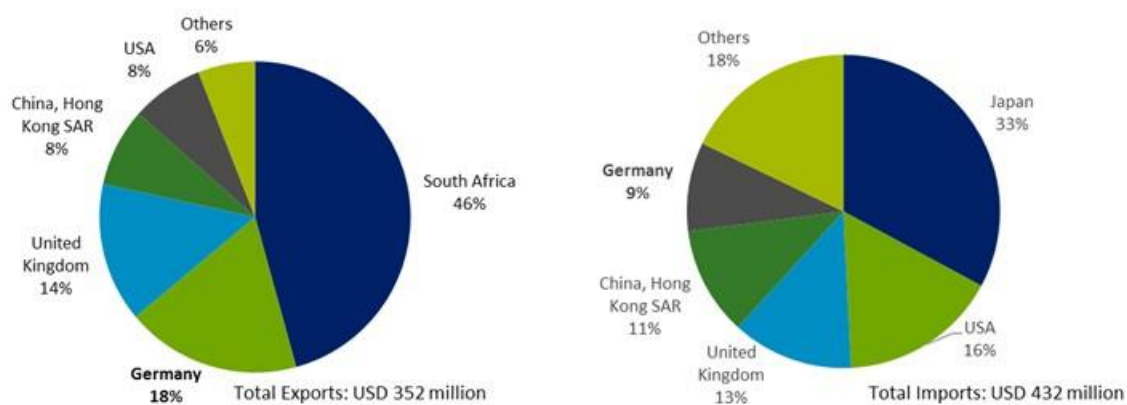
Over the 2016 to 2018 period, demand for ruthenium exceeded mine output, but sales from producer stocks have helped to keep the markets supplied. According to Johnson Matthey market analysis, strategic purchasing in Asia contributed to unusually large amounts of ruthenium shipped in 2017-2018 (Johnson Matthey, 2019a).

Almost all ruthenium derived from primary source materials (i.e. mine production) is traded in the form of refined products from integrated mining/metallurgical operations. There is only very limited international trade in ruthenium ores and concentrates (European Commission, 2017).

The Harmonised System does not separate trade flows for ruthenium metal, and trade data are available only under the single HS code 711041, which comprises "iridium, osmium and ruthenium metal in unwrought or powder form". South Africa is the leading world supplier of ruthenium-iridium-osmium metal; exports from South Africa accounted for 46% of international trade of ruthenium+iridium+osmium metal by value in 2017. Germany and the United Kingdom are also significant exporters with a market share of 18% and 14% respectively of global exports by value in 2017. Japan is the top importer of these three PGMs accounting for 33% of global imports by value in 2017. The USA and the UK are also significant destination countries for ruthenium+iridium+osmium metal with a share of 16% and 13%, respectively, of global imports by value.

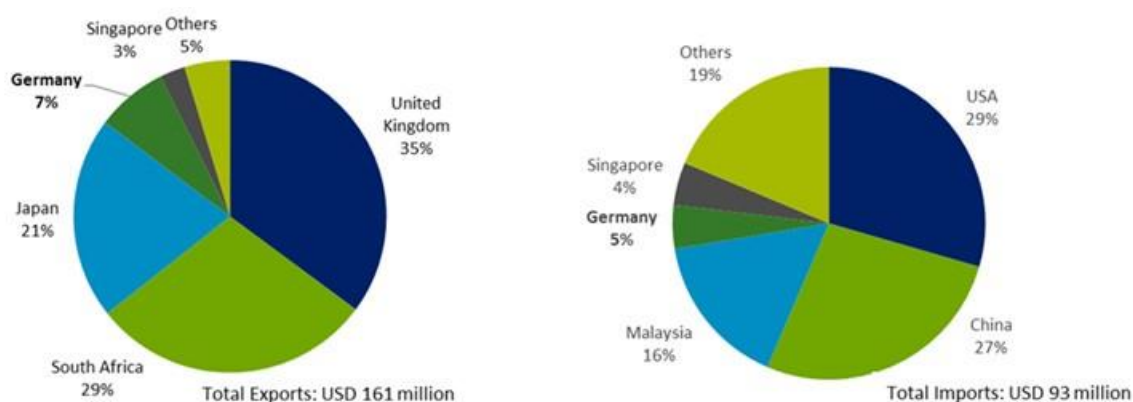
<sup>186</sup> Estimated as: 1,076,000 oz t of global gross demand in 2018 X 241 US\$/oz average price in 2018

<sup>187</sup> Gross demand is the sum of manufacturer demand for metal in that application and any changes in unrefined metal stocks.



**Figure 249: Top-5 iridium, osmium & ruthenium (unwrought/in powder form, HS 7110 41) exporting (left) and importing (right) countries in 2017 by value. Data from (UN Comtrade, 2019).**

The Harmonised System does not separate either trade flows for downstream ruthenium semi-finished products. Trade data are available only under the single HS code 7110 49, which involves “iridium, osmium and ruthenium metal in semi-manufactured forms”. The United Kingdom is the top world supplier of ruthenium-iridium-osmium in semi-manufactured forms with exports accounting for 35% of the total exports value in 2017. South Africa (29%) and Japan (21%) are also important exporters worldwide. The United States and China are the top importing countries of ruthenium+iridium+osmium in semi-manufactured forms accounting for 29% and 27%, respectively, of the global imports by value in 2017. Malaysia is also a significant destination of world exports of semi-manufactured forms of these three PGM, with a share of 16% of global imports by value in 2017.



**Figure 250: Top-5 iridium, osmium & ruthenium (in semi-manufactured forms, HS 7110 49) exporting (left) and importing (right) countries in 2017 by value. Data from (UN Comtrade, 2019).**

Concerning export taxes, quotas or export prohibition in place in 2017, Zimbabwe applied a 15% tax for HS 7110 41 “Iridium, osmium & ruthenium, unwrought or in powder form” and HS 7110 49 “Iridium, osmium & ruthenium, in semi-manufactured forms”. Russia imposed an export tax of 6.5% for both codes until 31/8/2016 (OECD, 2019).

## **19.2.3 General outlook for supply and demand of platinum group metals in general**

### **19.2.3.1 Forward look of PGM supply**

Given the importance of their industrial applications, the fact that PGMs are mined in only a few countries, and that are not readily substitutable, there has long been concern over security of supply of PGMs. Various actions have been taken since the late 1980s to ensure supply and mitigate the impacts of potential shortages. These have included the establishment of government stockpiles in some countries, promotion of recycling, research activities to understand deposit formation, the discovery of substantial additional mineral resources, and efforts to identify possible substitutes (European Commission, 2017a; Mudd, Jowitt and Werner, 2018).

Various studies have compared projected demand for PGMs with the amount of PGM resources that have been positively identified by mineral exploration. Along with the expected supply by recycling, it is suggested that geological availability is not an issue for PGM supply in the future. The known resources in the ground are considered sufficient, coupled with the potential for additional resource discoveries as well as for PGM extraction from different ore types, if market conditions are suitable (i.e. prices versus cost), to meet anticipated demand well for several decades (Zientek *et al.*, 2017; Mudd, Jowitt and Werner, 2018). USGS pointed to the existence of significant additional resources in under-explored areas adjacent to the Bushveld Complex in South Africa and the Great Dyke in Zimbabwe. Unexplored extensions of the Merensky Reef and the UG2 Chromitite may contain 33,000 tonnes of platinum and 32,000 tonnes of palladium in additional resources to a depth of 3 kilometres (Zientek *et al.*, 2017). The total extractable amounts of PGMs considering new technology for mining at great depths (up to 5 kilometres) may increase by more than two times in comparison with the identified resources to date (Sverdrup and Ragnarsdottir, 2016).

However, in the event of significantly higher demand, short-term supply shortages are possible despite resource availability, because of:

- As the PGM primary production is highly concentrated geographically, it is likely to be affected by social, environmental, political, and economic factors, rather than geological resource depletion (Hagelüken, 2019; Zientek *et al.*, 2017);
- PGMs are produced as by-products of nickel in Russia. Therefore, an increase in the output depends on concurrent higher nickel production;
- The development of new mines lasts several years and is associated with high financial and technical risks (Hagelüken, 2019).

In South Africa, various factors have combined in recent years to increasing concerns about the security of PGM supplies. Prominent among these are labour disputes over wages and working conditions, mining accidents which have led to shaft closures and lost production, as well as calls for nationalisation of the industry. In addition to rising wages, other costs have also increased significantly, including the price of power, water, fuel and materials. The effects of these have been exacerbated by the prolonged global recession continued economic uncertainties, low metal prices and fluctuating exchange rates (European Commission, 2017a). Since 2008, shaft closures have cut out over 37 tonnes of platinum capacity, 20 tonnes of palladium capacity and almost 6 tonnes of rhodium capacity in South Africa (Heraeus, 2019). The PGM output in South Africa fell from 311 tonnes in 2016 to 260 tonnes in 2017 (BGS, 2019), due to declining ore grades, rationalisation and shaft closures at large underground mines (European Commission, 2017a).

There has been a recent period of cost-cutting and industry restructuring, but major capital investment is needed to increase mechanisation in the mines, to develop new mining

capacity, and to restore sustainable profitability and secure jobs (IPA Industrial expert, 2019). Various mines have closed or are being considered for closure, while others have changed ownership. South Africa will likely remain the dominant global supplier of PGMs, because of its vast resource base, the established mining and processing infrastructure and expertise, and the great importance of the PGM industry to the economy of South Africa. However, it is also probable that there will be less, but more modern operations employing fewer workers (European Commission, 2017a).

In the Norilsk-Talnakh area in Russia, the PGMs (chiefly palladium) are essentially a by-product of nickel mining, so it is difficult to assess the long-term availability of PGMs from these mines, especially when nickel prices remain at low levels. For many years PGM supplies from Russia were supported by sales from government stocks. Although these sales have now ceased, the stocks are now owned by the Russian central bank and, depending on prices and other factors, may provide an additional source of future supply. The other source of Russian PGM supply is alluvial mining operations in the Far East. These provide only a small proportion of Russia's output, whereas grades are reported to be falling, so their share is likely to continue to decrease as it has been since 2014 (European Commission, 2017a).

Recycling currently makes already an important contribution to PGM supply and, given favourable economic conditions and supportive legislation, the share of PGMs from secondary materials is likely to increase as end-of-life products are collected more efficiently and processed using the optimum technology (European Commission, 2017a).

### **19.2.3.2 Forward look of PGM demand for autocatalysts**

Catalytic converters for motor vehicles will likely remain the most significant demand sector for PGM for the foreseeable future. It is also considered likely to grow further as a result of increasing vehicle sales, both light-duty and heavy-duty, and stricter emission standards and testing regimes (IPA industrial expert, 2019). Nevertheless, the projected rapid growth in battery electric vehicles (BEVs) is going to affect the demand for PGM.

Since the early 1990s, the use of platinum-rich diesel catalysts has become universal, and PGM loadings increased to meet tightening tailpipe emissions standards. Euro 6b emissions limits (introduced in September 2014 and since September 2015 enforced on all new passenger cars registered in Europe) led to a rise in the average platinum loadings in diesel autocatalyst systems in Europe (Johnson Matthey, 2015; Johnson Matthey, 2016). In 2016, the total demand for platinum from the European vehicle sector reached its highest level since 2008 (Figure 250). Autocatalysts accounted for 75% of the European demand for platinum in 2018, and diesel catalysts used in light and heavy-duty vehicles and off-road applications account for 95% of automotive platinum usage in Europe (Johnson Matthey, 2016). Despite a decline in the popularity of diesel cars in the region since 2015, Europe remains the largest global market for diesel vehicles and accounts for over half of diesel cars manufactured globally.

In the EU, Real Driving Emissions (RDE) standards are being phased in between 2017 and 2022 for both gasoline and diesel vehicles under Euro 6d legislation. These changes, which will restrict the permitted difference for NO<sub>x</sub> and PN emissions under real driving and laboratory test conditions, will have significant impacts on the diesel catalysts developed by European carmakers and have greatly increased the complexity and variety of diesel catalyst systems in use (Johnson Matthey, 2016). PGM-containing catalysts are still required in all diesel vehicles sold in Europe, but increased use of selective catalytic reduction (SCR), and combined SCR-particulate filter technologies - to tightly control NO<sub>x</sub> and PN emissions under RDE testing - has led to a decline in average platinum (and overall PGM) loadings since 2016 (Johnson Matthey, 2019a).

The automotive industry also dominates demand for palladium and rhodium, accounting for 85% of global gross demand in 2018 (Johnson Matthey, 2019a). European demand for palladium was estimated at 64 tonnes in 2018, with nearly 59 tonnes used by the automotive industry representing a share of 92% of the total demand in Europe. In recent years, consumption of both metals has expanded ahead of growth in vehicle sales as average PGM catalyst loadings have risen to meet tighter emissions legislation. The recent introduction of the RDE testing in Europe has driven average catalyst loadings higher on most vehicles (Johnson Matthey, 2019a).

The next stage of European legislation ('Euro 7') with an expected entry into force somewhere around 2023-2025, is not yet defined but is likely to tighten emissions limits further. Implementation of these tighter regulations may lead to renewed upward pressure on PGM loadings, though the result will depend on the timing, the severity and nature of the limits.

Consideration for the future is the potential use of platinum in gasoline emissions catalysts. For gasoline-powered vehicles, palladium-rhodium three-way catalysts (TWCs) are typically employed. Platinum is also active for CO and HC oxidation and was the dominant choice of metal for these catalysts when TWCs were first developed in the mid-70s through to the early 90s, before the use of low sulphur fuel made increasing use of (cheaper) palladium-containing TWCs possible. However, the reversal in the platinum to palladium price ratio since September 2018 has led to increasing speculation over a potential switch back from palladium to platinum in gasoline catalysts. While any large scale move towards greater use of platinum in gasoline catalysts would significantly impact the demand outlook for both platinum and palladium, there remain a number of technical and practical hurdles to overcome before OEMs would be ready and confident to consider a switch (IPA industrial expert, 2019).

At the same time, internal combustion engines (ICE) will be increasingly replaced by electric vehicles of various types, driven by progressively stringent CO<sub>2</sub> targets around the world. Hybrid electric vehicles will still require PGM-containing catalysts to treat emissions from the ICE. But in the case of zero tailpipe emission vehicles, pure battery electric vehicles (BEVs) have no ICE and do not require a catalyst, and so their increasing use will displace PGM demand. Alongside BEVs, fuel cell electric vehicles (FCEVs), which use a platinum catalyst, will play a vital role in the decarbonisation of the transport sector. This is not only true in the passenger car segment; fuel cell vans, but buses and trucks are also increasingly seen as being a crucial part of the transition to clean forms of transportation in the heavy-duty sector (Johnson Matthey, 2018).

While BEVs are gaining far more media attention currently, most major OEMs invest in both BEV and FCEV technologies, to satisfy the varied requirements of a diverse customer base. As a rapidly evolving market, long term views differ extensively, but most automotive experts agree that the future vehicle fleet will comprise a mix of hybrids, BEVs and FCEVs. BEVs are seen as the most practical and efficient option for vehicle segments where range requirements are limited (or more frequent refuelling is a feasible option), and FCEVs particularly suitable to segments where long-range and/or high utilisation rates are desirable (Johnson Matthey, 2018). With FCEV demand, therefore, set to grow in all transport sectors, over the longer-term platinum demand in the automotive industry is expected to rise.

Demand for PGMs in the fuel cell industry will become significant in the long term only if fuel cell electric vehicles (FCEVs) obtain a sizeable share of light-duty vehicle production. Fuel cell-powered electric car production was currently approaching 10,000 per year but is predicted to grow by orders of magnitude until 2040. However, PGM demand for fuel cells and hydrogen technologies is several years away from being significant (Heraeus, 2019).



## 19.2.4 Outlook for supply and demand of individual platinum group metals

### 19.2.4.1 Outlook for supply and demand of iridium

#### *Forward look for iridium supply*

It is considered that South Africa will continue to be the leading supplier of iridium worldwide. Most PGMs in South Africa are currently mined from the UG2 Chromitite layer, Bushveld Complex, that hosts larger PGM resources than the Merensky Reef, and, additionally, it contains a higher proportion of iridium; the iridium to platinum ratio in Merensky Reef is reported 1:50, while in the UG2 the ratio is 1:20 (Angerer et al., 2016). Thus, geologic availability is considered unlikely to be problematic for the future availability of iridium from South Africa.

Primary production of iridium is linked to platinum and palladium extraction; therefore it is set to grow or decrease in line with the production of these metals. Any drastic disruption in the output of platinum and palladium from South Africa will also have an effect on iridium availability. Similarly, it is not possible to adapt supply to demand fluctuations of the "minor PGMs", e.g. because of new technological developments, with stable production of the host PGMs (Hagelüken, 2019). A short-term escalation in demand can be met from stored iridium-containing intermediate products of PGM refining (Angerer et al., 2016).

With regard to the overall supply outlook, it can be argued that platinum's output from primary sources will grow in the longer term (20 years) to keep up with the anticipated increase in platinum's demand in 2035 and beyond (see the Platinum factsheet), and therefore, iridium's supply as a co-product will increase proportionally.

#### *Forward look for iridium demand*

The outlook for iridium is firm in the short-term. The anticipated strong growth in demand for electrochemical applications is expected to support overall demand. International Maritime Organisation's (IMO's) 'International Convention for the Control and Management of Ship's Ballast Water and Sediments' requires the mandatory addition of ballast water treatment technology to new ships and in the longer term the retrofitting of existing vessels. Treatment technology, using electrodes coated with ruthenium and iridium, is one of several ballast water treatment options available (Johnson Matthey, 2019a). In the electrical sector, iridium usage in organic light-emitting diodes (OLEDs) used in displays for electronic devices (mobiles phones, TVs) is also expected to grow (Johnson Matthey, 2019a).

In addition, iridium is a material used together with platinum in fuel cells, i.e. in polymer electrolyte membrane fuel cells (PEM). In the longer term, this application represents an area of supplementary demand, but the impact will depend on the market penetration of fuel cell electric vehicles (FCEV); their number would have to grow significantly to make a significant impact. Heraeus forecasts a gradually increasing platinum demand for FCEVs from 2030 onwards, and therefore, a supplementary demand for iridium (Heraeus, 2019).

For the overall qualitative assessment of the outlook of iridium's supply and demand, it is difficult to predict with confidence the impact of the above projections.

**Table 105: Qualitative forecast of supply and demand of iridium**

Material	Criticality of the material in 2020		Demand forecast			Supply forecast		
	Yes	No	5 years	10 years	20 years	5 years	10 years	20 years

Iridium	X		+	?	+	0	?	+
---------	---	--	---	---	---	---	---	---

#### 19.2.4.2 Outlook for supply and demand of palladium

##### *Forward look for palladium supply*

It is expected that Russia and South Africa will continue to be the leading global suppliers of palladium. Although palladium may be considered as a by-product of nickel mining in Russia, it is unlikely that this will become a constraint on palladium supply, at least in the short term.

##### *Forward look for palladium demand*

The general factors affecting the future demand for PGM in the automotive sector are discussed in the PGM factsheet.

In the short term, the imposition of increasingly strict emission control legislation across the world is likely to continue to increase demand for palladium in autocatalysts. In the longer term, the move away from carbon-based fuels for powering road vehicles may lead to reduced demand for palladium.

Forecasts on the future use of PGM and palladium up to 2035 for Europe and worldwide were developed in the context of the H2020 SCRREEN project (Tercero, 2019) (Ait Abderrahim and Monnet, 2018). The results of the base scenario show that only the use of palladium in the chemical sector is expected to grow significantly in the EU and globally in absolute terms, while dental applications are almost disappearing in the rest of the world. The application that is expected to undergo significant changes in the next two decades for palladium demand is autocatalysts. According to the base scenario for the mobility sector, a decrease in PGM and therefore palladium demand for autocatalysts by 59% from 2017 to 2035 is considered plausible. It is indicated by (Tercero, 2019) that in 2035 the overall palladium consumption is projected to be 191 tonnes globally and 34 tonnes in Europe (of which 21 tonnes for autocatalysts). These projections can be compared with the global demand for palladium in 2018, i.e. 318 tonnes globally and 64 tonnes in Europe, as reported by (Johnson Matthey, 2019a).

Also, two different deployment scenarios were considered for electric vehicles in Europe's transportation sector ("Tech 2" and "Tech 3") as described in the JRC report by (Blagoeva *et al.*, 2016), which were updated and adjusted. According to the more conservative scenario "Tech 2", which assumes a strong market penetration by hybrid electric vehicles (HEVs) and a slower decrease in market share of gasoline-fuelled cars, the demand for palladium in autocatalysts is decreasing significantly from 52 tonnes in 2017 (84% of EU consumption) to 20 tonnes in 2035 (61% of EU consumption), which is very close to the base scenario. In this scenario, the total European demand for palladium in 2035 is projected to be 33 tonnes. In the "Tech 3" scenario, which suggests a rapid breakthrough of the more advanced technologies of plug-in hybrid electric vehicles (PHEV), battery electric vehicles (BEV) and fuel cell electric vehicles (FCEV), palladium demand for autocatalysts drops from 52 tonnes in 2017 (84% of EU consumption) to 14 tonnes in 2035 (52% of EU consumption), with a total European palladium consumption of 27 tonnes in 2035.

In another study, it has been suggested that global demand for palladium will increase due to emerging technologies (Marscheider-Weidemann *et al.*, 2016). The main palladium-containing future technologies identified are the micro-electric capacitors and seawater desalination. The demand for palladium from emerging technologies is estimated to increase fivefold from 2013 to 2035, i.e. from 20 tonnes in 2013 to 100 tonnes in 2035.

It is difficult to predict future palladium demand for jewellery and investment as it varies considerably by country in response to cultural attitudes and changing metal prices (European Commission, 2017).

For the overall qualitative assessment for the outlook of palladium’s demand, it is challenging to forecast if the ongoing increase in loadings in catalytic converters will offset the decrease in demand by the lower number of ICE vehicles in 5 years from now. For the qualitative estimation of palladium’s demand in 10 and 20 years, the forecasts developed by the SCRREEN project are applied (Tercero, 2019)

**Table 106: Qualitative forecast of supply and demand of palladium**

Material	Criticality of the material in 2020		Demand forecast			Supply forecast		
	Yes	No	5 years	10 years	20 years	5 years	10 years	20 years
Palladium	X		?	-	-		-	-

### 19.2.4.3 Outlook for supply and demand of platinum

#### *Forward look for platinum supply*

It is considered that South Africa will continue to be the leading global supplier of platinum.

#### *Forward look for platinum demand*

General factors affecting the future demand for PGM in the automotive sector are also discussed in the PGM factsheet.

With the expected transformation of the transport sector from a combustion engine-based system towards electric mobility, the overall use of platinum will undergo significant changes in the next decades, and these changes will be more severe for Europe since European platinum demand is much more dependent on autocatalysts than the demand in the rest of the world is (Tercero, 2019).

In the short term, the imposition of increasingly strict emission control legislation worldwide is likely to increase demand for platinum in autocatalysts. In the longer term, the move away from carbon-based fuels for powering road vehicles will lead to reduced demand for platinum in catalytic converters. However, if fuel cell vehicles achieve significant market penetration in the future, platinum demand in the automotive sector will likely rise over the longer term.

It is difficult to predict future platinum demand for jewellery and investment as it varies considerably by country in response to cultural attitudes and changing metal prices. However, in recent years platinum jewellery demand (which accounts for the vast majority of PGM use in the jewellery sector) has been in decline. A progressively weaker platinum price (and, since 2015 its discount to gold) has challenged the consumer perception of platinum as the premium jewellery metal in the largest market of China. Intense competition from alternative metals, as well as the luxury market at large, have also acted to dampen demand. While interest in platinum jewellery in India has grown strongly in recent years (albeit from a low base), this has, so far at least, failed to offset the decline in the Chinese market. (IPA industrial expert, 2019)

Industrial consumption of platinum in chemicals, glass and petroleum refining has been at historically elevated levels over the last decade, due to a large extent to significant investment in new plants and expansions by China and Chinese-owned plants in other regions (Johnson Matthey, 2019b).

Forecasts on the future use of platinum and other PGM until 2035 for Europe and worldwide were developed in the context of the H2020 SCRREEN project (Tercero, 2019) (Ait Abderrahim and Monnet, 2018). The base scenario, which does not take into account fuel cell electric vehicles (FCEVs) as a possible alternative to internal combustion engine (ICE) cars, results in a constant drop of platinum use in Europe from 2017 to 2035 due to the steady decline of the autocatalyst sector, i.e. from 53 tonnes in 2017 (Johnson Matthey, 2019b) to 23 tonnes in 2035. Platinum use in chemical and other applications is predicted to increase slightly but stays on a low level, while other sectors are expected to be stagnant until 2035. In this scenario, the overall consumption of platinum projected for Europe in 2035 is 45 tonnes. Results of the global forecast are similar. However, the growth of chemical and other uses is even stronger worldwide, almost balancing the decreasing demand for autocatalysts from about 101 tonnes in 2017 (Johnson Matthey, 2019b) to 42 tonnes in 2035. The global platinum consumption for 2035 is predicted to be 223 tonnes, and this can be compared with the worldwide demand for platinum in 2018 of 248 tonnes (Johnson Matthey, 2019b).

In order to take into account different scenarios for the deployment of electric vehicles in Europe, the two scenarios ("Tech 2" and "Tech 3") described in the JRC report by (Blagoeva et al., 2016) were considered and adjusted. In the more conservative "Tech 2" scenario assuming a strong market penetration of HEVs and only very slowly increasing shares of the more advanced technologies of BEVs and especially FCEVs, the overall platinum demand in Europe starts to increase again in 2025 (72 tonnes in 2017, 75 tonnes in 2035). In the "Tech 3" scenario, which assumes a more rapid introduction rate and stronger market penetration of BEVs and FCEVs, European platinum demand increases quickly, surpassing the level of 2017 already in 2023 and rising even further to 100 tonnes in 2035. However, both scenarios predict a decreasing platinum demand in Europe for the next five years due to progressing market penetration of electric vehicles and a consequently shrinking requirement for autocatalysts in vehicles with internal combustion engines (Tercero, 2019).

In the global context, the forecasted rise of demand because of platinum's use in emerging technologies may require significant increases in platinum production. The projected rise of demand is estimated up to 110 tonnes in 2035 by (Marscheider-Weidemann et al., 2016), driven by fuel cell electric vehicles that may require up to about 90 tonnes per year of platinum, depending on the market penetration. This can be compared with the global mine production of platinum in 2017 of 182 tonnes (WMD 2019).

For the overall qualitative assessment for the outlook of platinum's demand, it is uncertain if the ongoing increase in loadings in catalytic converters will offset the decrease in demand by the lower number of ICE vehicles in 5 years from now. For the qualitative estimation of platinum's demand in 10 and 20 years, the forecasts developed by the SCRREEN project are applied (Tercero, 2019). As concerns supply, it is assumed that geological availability of PGM in South Africa is such that there will be no restriction in supply if significant increases in platinum production are required.

**Table 107: Qualitative forecast of supply and demand of platinum**

Material	Criticality of the material in 2020		Demand forecast			Supply forecast		
	Yes	No	5 years	10 years	20 years	5 years	10 years	20 years
Platinum	x		?	0	+	+	+	+

#### **19.2.4.4 Outlook for supply and demand of rhodium**

##### *Forward look of rhodium supply*

It is considered that South Africa will continue to be the main global supplier of rhodium. Nevertheless, it is reported that rhodium supplies from South Africa are forecast to decline as shaft closures at Lonmin and Impala Platinum are implemented, and as some other UG2 operations are near the end of their lives. The UG2 reef is richer in rhodium than other PGM ores mined in South Africa, so the depletion and closure of UG2 operations will be particularly significant for rhodium supply. Growth in autocatalyst recycling may not be enough to offset the future contraction in mine production of rhodium. The scope for growth in rhodium recovery from autocatalysts is lower for rhodium than for palladium due to rhodium thrifting programmes in the past, particularly on North American and European cars (Johnson Matthey, 2019a).

##### *Forward look of rhodium demand*

The short-term outlook for demand is positive as car manufacturers are increasing PGM loadings in response to tighter emissions legislation and more stringent testing. According to Johnson Matthey projections, the autocatalyst demand is expected to increase by 10% in 2019, and the global rhodium demand to reach record levels (Johnson Matthey, 2019a). The major drivers of the increased rhodium demand for autocatalysts will be China and Europe. In China, a step-change in loadings on vehicles is underway due to a regulatory tightening. In Europe, an upward trend in rhodium loadings is expected as a result of more stringent testing of passenger vehicles. In particular, from September 2019 all new passenger cars sold in Europe will have to comply with Euro 6d-TEMP standards, which require vehicles to demonstrate NO<sub>x</sub> and particle number (PN) emissions compliance in Real Driving Emissions (RDE) testing as well as in laboratory tests. The final phase of Euro 6d will be implemented starting in January 2020, further limiting permitted NO<sub>x</sub> emissions. At the same time, from January 2019 new in-service conformity regulations apply intended to ensure that catalyst systems meet RDE standards not just at the point that the vehicle is put into service, but for most of its lifetime. Because rhodium is a particularly effective catalyst for NO<sub>x</sub>, the impact of Euro 6d legislation on rhodium demand has been particularly significant (Johnson Matthey, 2019a). However, despite demand from the automotive sector is set to rise strongly due to increased rhodium loadings within the next 1-2 years, the absolute increase in rhodium's demand for autocatalysts in the near future will depend on gasoline car production and the market penetration of electric vehicles, so the trend is considered uncertain in 5 years from now.

In the mid- to longer-term, rhodium's demand is expected to undergo significant changes due to turning away from vehicles with internal combustion engines towards the use of electric vehicles. The H2020 SCRREEN project (Tercero, 2019) (Ait Abderrahim and Monnet, 2018) developed forecasts on the future use of PGMs up to 2035 for Europe and worldwide. In the base scenario for the global rhodium demand, a sharp decrease in demand for autocatalysts is predicted while the other sectors (chemical, glass and other uses) show a rising demand until 2035. The overall rhodium consumption is contracted by about 18% from 32.7 tonnes in 2017 (Johnson Matthey, 2019a) to 27 tonnes in 2035. The projection is similar for Europe as in 2035 rhodium demand decreases by 33% compared to 2017 to 2.7 tonnes, consisting of 48% for autocatalysts, 29% for the glass industry, 20% for chemical and 3% for other uses.

In order to take into account different scenarios for the penetration of electric vehicles in the European automobile sector, the two scenarios ("Tech 2" and "Tech 3") described in the JRC report by (Blagoeva *et al.*, 2016) were considered and adjusted. The "Tech 2" scenario, consisting of a slightly slower decreasing market share of gasoline-fuelled cars and an intense market penetration of hybrid electric vehicles (HEV), results in significant

lower demand for rhodium in autocatalysts in the EU, from 3.2 tonnes in 2017 to 1.3 tonnes in 2035, as an autocatalyst is needed only for 72% of new cars in 2035; the overall European demand for rhodium in 2035 totals also 2.7 tonnes in this scenario. In the "Tech 3" scenario, which assumes rapid uptake rates for advanced electric vehicles (EVs), i.e. (BEVs and PHEVs), the share of new cars containing an internal combustion engine and, therefore, requiring an autocatalyst in 2035 is only 49%. Hence, the rhodium demand for autocatalysts is forecasted to drop from 3.2 tonnes in 2017 to 0.8 tonnes in 2035 with a total European rhodium consumption of 2.3 tonnes of rhodium in 2035 (Tercero, 2019).

The qualitative forecast for the world supply and demand for rhodium is presented in Table 108.

**Table 108: Qualitative forecast of supply and demand of rhodium**

Material	Criticality of the material in 2020		Demand forecast			Supply forecast		
	Yes	No	5 years	10 years	20 years	5 years	10 years	20 years
Rhodium	X		?	-	-	0/-	0/-	0/-

#### 19.2.4.5 Outlook for supply and demand of ruthenium

##### *Forward look for ruthenium supply*

It is considered that South Africa will continue to be the main global supplier of ruthenium. Most PGMs in South Africa are today mined from the UG2 Chromitite layer, Bushveld Complex, which hosts larger PGM resources than the Merensky Reef. As long as the UG2 ore contains a higher proportion of ruthenium than the Merensky Reef, the future availability of ruthenium from South Africa is considered unlikely to be problematic in terms of geological availability.

On the other hand, as ruthenium is a co-product of platinum and palladium production, a drastic disruption in the output of these host PGMs from South Africa poses a risk for future ruthenium supply. Likewise, it is not possible in practice to adapt supply to demand fluctuations, e.g. because of new technological developments, with stable production of the host PGMs (Hagelüken, 2019). A short-term escalation in demand can be met from stored ruthenium-bearing intermediate products of PGM refining (Angerer *et al.*, 2016).

The recycling rate of ruthenium from consumer products is currently very low. Given favourable economic, technical and regulatory conditions improved ruthenium recovery from sources such as WEEE might be envisaged (European Commission, 2017). A recent price-related increase in recycling of ruthenium old catalysts may continue in the future (Johnson Matthey, 2019a).

As concerns the overall outlook of supply, it can be expected that the projected significant increase in platinum's demand in 2035 (see Platinum factsheet) will be met by increased output from primary sources, and therefore, ruthenium's availability as a co-product will be increased proportionally. It is also assumed, that the current trend of high prices for ruthenium will be maintained in the short-term, and, therefore, supply from secondary sources will grow contributing to overall supply in the short-term (5 years).

##### *Forward look for ruthenium demand*

The outlook for ruthenium in the short-term is firm. Demand for hard disk drives, which are based on perpendicular magnetic recording in which ruthenium plays an important role, is expected to grow even though their share in the market is declining from the competing solid-state (flash) drives (Johnson Matthey, 2019a). For catalytic applications,

demand growth is also expected because of new caprolactam and adipic acid capacity in China; there is also a potential for new ruthenium demand arising from the commercialisation of new catalytic processes (Johnson Matthey, 2019a). For electrochemical applications, a growth in demand should also be anticipated due to the mandatory fitment of ballast water treatment technology to new ships required by the International Maritime Organisation’s (IMO’s) ‘International Convention for the Control and Management of Ship’s Ballast Water and Sediments’; in the longer term, existing ships will also need to be retrofitted. Treatment technology, using electrodes coated with ruthenium and iridium, is one of several ballast water treatment options available (Johnson Matthey, 2019a). In the longer term (20 years), a supplementary demand for ruthenium can be anticipated from 2030 onwards due to the growing market penetration of fuel cell electric vehicles (FCEVs) (Heraeus, 2019).

For the overall qualitative assessment of the outlook of ruthenium’s supply and demand, it is difficult to predict with confidence the impact of the above projections, especially in the 10 years horizon (see Table 109).

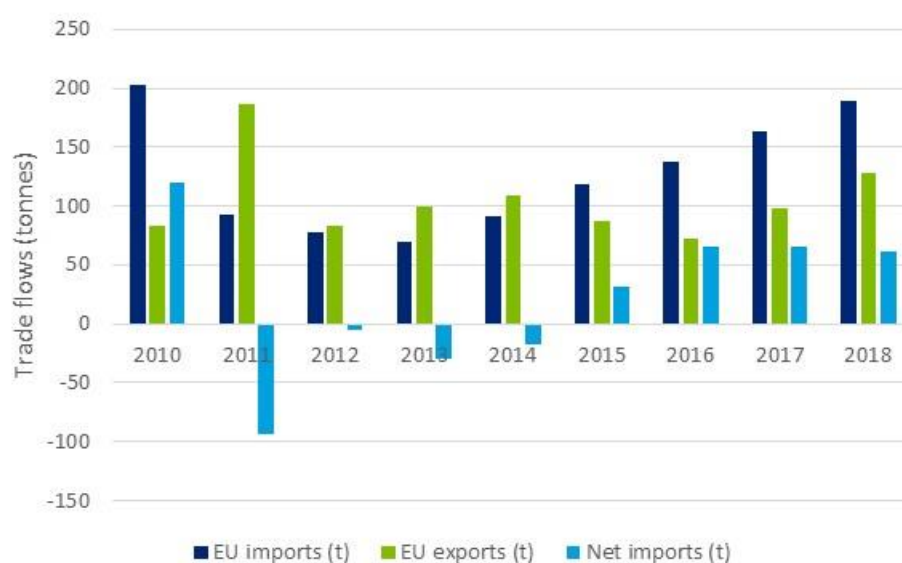
**Table 109: Qualitative forecast of supply and demand of ruthenium**

Material	Criticality of the material in 2020		Demand forecast			Supply forecast		
	Yes	No	5 years	10 years	20 years	5 years	10 years	20 years
Ruthenium	X		+	?	+	+	?	+

## 19.3 EU Trade

### 19.3.1 General EU trade of platinum group metals

Figure 251 presents the physical trade flows of PGMs in unwrought and powder form. It is apparent that after a period of decline (2010-2013), imports are continuously increasing from 2014 onwards; in 2018 total imports amounted to about 190 tonnes, close to the highest level that has been recorded since 2010 (203 tonnes). It is also apparent that the EU, after a period of net exports (2011-2014), has become again a net importer of PGMs in unwrought or in powder form since 2015. In 2013, in which the lowest level of imports is observed, demand for platinum and palladium in Europe was also at its lowest level in the period 2010-2018, i.e. about 110 tonnes when it typically ranges from 120-125 tonnes.

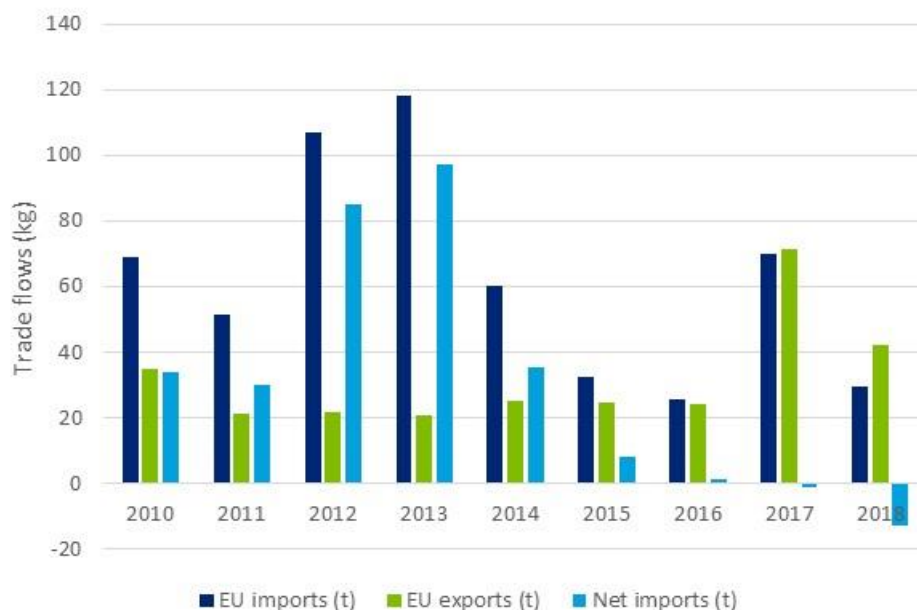


**Figure 251: Trends in extra-EU trade for all PGMs in unwrought and powder form. Data<sup>188</sup> from (Eurostat, 2019a)**

As regards trade of PGMs in semi-manufactured forms, imports of PGMs from extra-EU countries outweighed exports significantly from 2010 to 2015 (see Figure 252). The spikes in the trade balance observed in 2012 and 2013 are due to unusually high amounts of PGMs imported from the United Kingdom in those years. Imports of semi-manufactured forms of PGM were the highest in 2013 during the period 2010-2018 (see Figure 252). In 2016 and 2017, trade flows were relatively balanced. The EU became a net exporter for the first time in 2018 within the timeframe 2010-2018, as exports increased considerably.

<sup>188</sup> For trade codes: 7110 11“Platinum, unwrought/in powder form”, HS 7110 21“Palladium, unwrought/in powder form”, HS 7110 31“Rhodium, unwrought/in powder form”, 7110 41“Iridium, osmium & ruthenium, unwrought/in powder form”





**Figure 252: Trends in extra EU trade for all PGMs in semi-manufactured forms. Data<sup>189</sup> from (Eurostat, 2019a)**

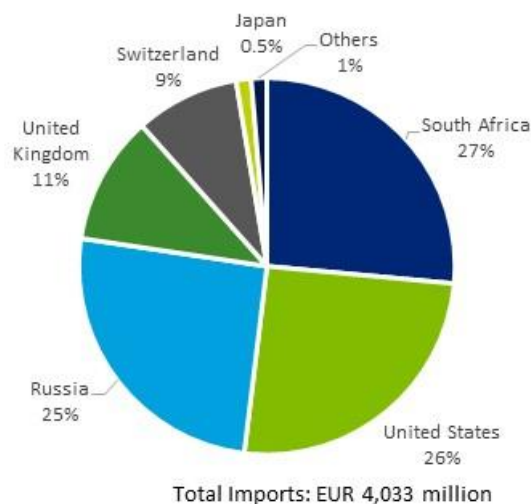
Figure 253 demonstrates the overall EU-extra trade balance by value for all PGMs in unwrought, powder and semi-manufactured forms. It is noted that in spite of the steady increase of imports value from 2013 to 2017, the EU-extra trade balance is generally negative (except for 2012 and 2013). Furthermore, the trade balance is significantly more negative in the latter years (2015-2018). These trends can be attributed to increasing quantities of imports, in combination with palladium's rising price and growing demand in Europe.

<sup>189</sup> For trade codes: HS 7110 19 "Platinum, in semi-manufactured forms", HS 7110 29 "Palladium, in semi-manufactured forms", HS 7110 39 "Rhodium, in semi-manufactured forms", HS 7110 49 "Iridium, osmium & ruthenium, in semi-manufactured forms"



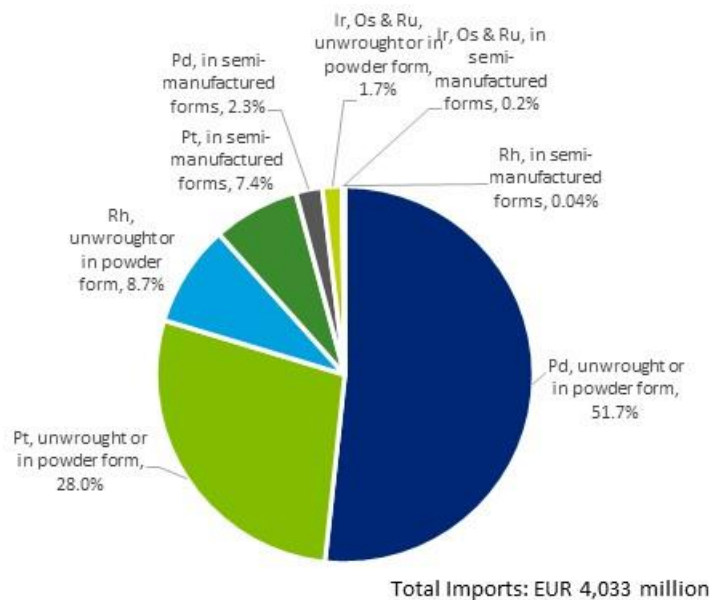
**Figure 253: Trends in extra-EU trade balance for all PGMs in unwrought, powder and semi-manufactured form. Data from (Eurostat, 2019a)**

South Africa, the United States, Russia, United Kingdom and Switzerland are the chief suppliers of PGMs to the EU (Figure 254). Switzerland, in particular, has traditionally been a central point of PGM storage and distribution by producers, traders and bankers and has significant precious metal refining capacity. Major platinum and palladium exchange-traded funds, which are based on physical holdings of these metals, are also located in Switzerland (European Commission, 2017a).



**Figure 254: Sources of EU imports in 2018 for PGM in unwrought, powder and semi-manufactured form by value. Data from (Eurostat, 2019a)**

Figure 255 reflects the distribution of EU imports value by product category. Palladium products have a dominant position in the value of EU imports, with a total share of 54%, followed by platinum (35%), rhodium (9%), and iridium, osmium & ruthenium (2%).



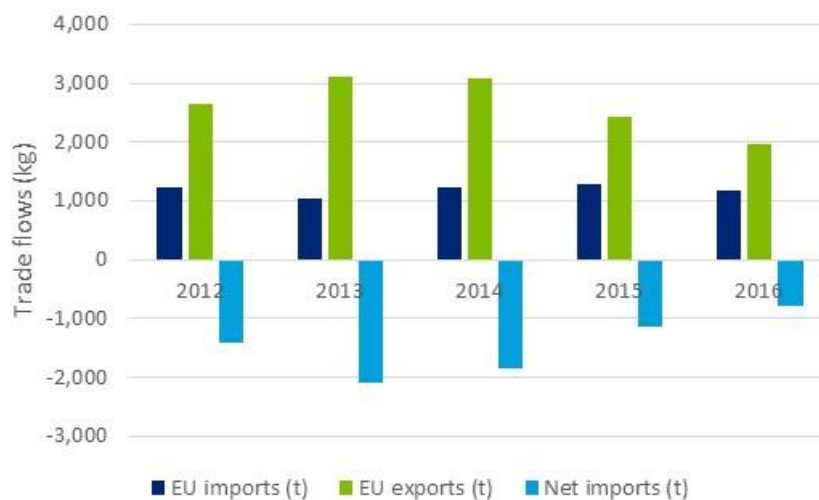
**Figure 255: EU imports value in 2018 by PGM product group in unwrought, powder and semi-manufactured form. Data from (Eurostat, 2019a)**

### 19.3.2 EU trade of individual platinum group metals

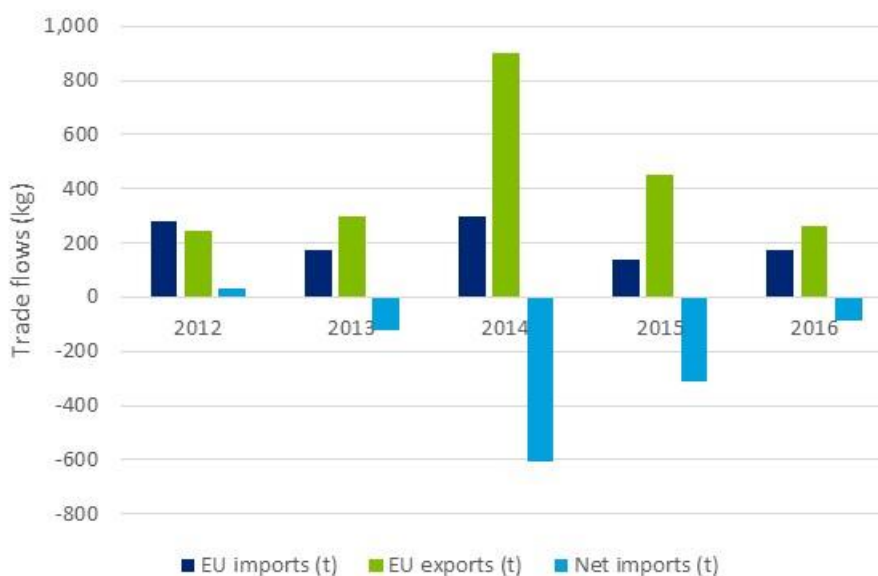
#### 19.3.2.1 EU trade of iridium

As discussed in section 19.3.1, PGMs are traded in the EU in a variety of forms – as metal in unwrought or powder form, in semi-manufactured forms and various intermediate products and wastes. For iridium, trade data were analysed for trade codes HS code 7110 41 “Iridium, osmium and ruthenium in unwrought or powder form”, and HS 7110 49 “Iridium, osmium and ruthenium metal in semi-manufactured forms”. The relative proportion of iridium in the EU trade flows in the above aggregated trade codes was estimated by assuming trade flows for osmium to be negligibly small and, thus, set to zero. Also, by considering that the disaggregated trade flows for ruthenium and iridium are proportional to their world demand. The relative size of their markets was derived from data published by (Johnson Matthey, 2019a), and has been calculated at 83% ruthenium and 17% iridium, as an average over the 2012-2016 period.

In all years from 2012 to 2016, the EU was a net exporter of iridium in unwrought or powder form. Net exports averaged to 1.5 tonne per year. As it is demonstrated in Figure 256, the evolution of EU net exports since 2013 is towards lower levels, due to declining exports. For iridium in semi-manufactured forms, the EU was also a net exporter on average in years 2012-2016 (Figure 256). From the above figures, it is concluded that the EU is a considerable world supplier of refined iridium; however, it is not possible to determine how much of this metal was derived from primary or secondary sources.



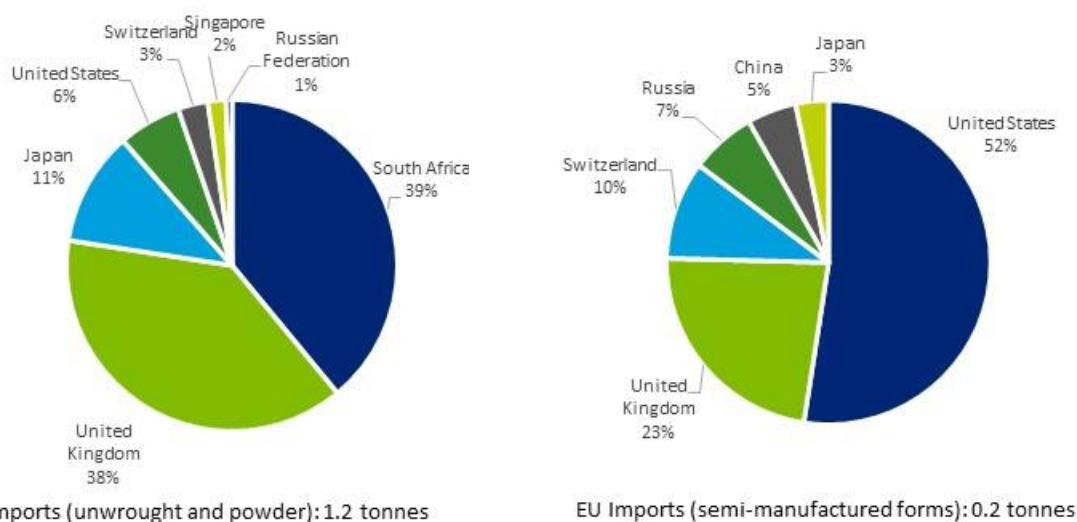
**Figure 256: Estimated EU trade flows for iridium in unwrought or powder form. Background data from (Eurostat, 2019<sup>a</sup>, Johnson Matthey, 2019a)**



**Figure 257: Estimated EU trade flows for iridium in semi-manufactured forms, Background data from (Eurostat, 2019<sup>a</sup>, Johnson Matthey, 2019a).**

EU imports of iridium, in unwrought or powder form, averaged to about 1.2 tonnes per annum between 2012 and 2016. The key sourcing countries were South Africa (39%), the UK (38%), and Japan (11%) (Figure 258). In the same period, the average annual EU exports amounted to about 2.6 tonnes of iridium metal, in unwrought or powder form. Singapore was the top destination of exports (75% of the total), followed by the US (9%).

The annual average EU imports of iridium in semi-manufactured forms were about 0.2 tonnes from 2012 to 2016. The United States was the main source country (52%), followed by the United Kingdom (23%) and Switzerland (10%) (Figure 258). In the same period, the EU exported annually about 0.4 tonnes of iridium in semi-manufactured forms. Turkey (48%) was the major destination of EU exports, followed by Brazil and Singapore (13% each).



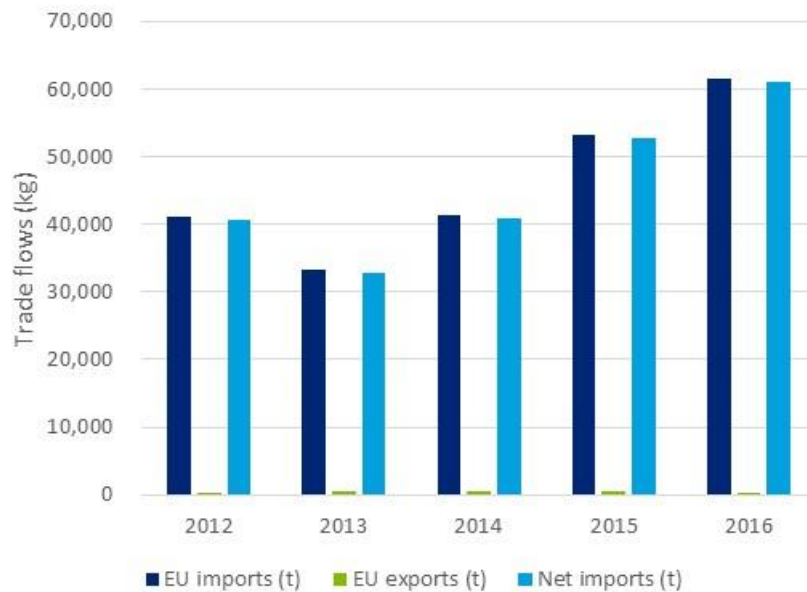
**Figure 258: Origin countries for EU imports of iridium metal in unwrought or powder form (left), and in semi-manufactured forms (right), average 2012-2016. Background data from (Eurostat, 2019a, Johnson Matthey, 2019a).**

In 2017, there were no export taxes, quotas or export prohibition in place between the EU and its suppliers for HS 7110 41 “Iridium, osmium & ruthenium, unwrought or in powder form” and HS 7110 49 “Iridium, osmium & ruthenium, in semi-manufactured forms”. The EU and South Africa have a trade agreement in place (European Commission, 2019).

### 19.3.2.2 EU trade of palladium

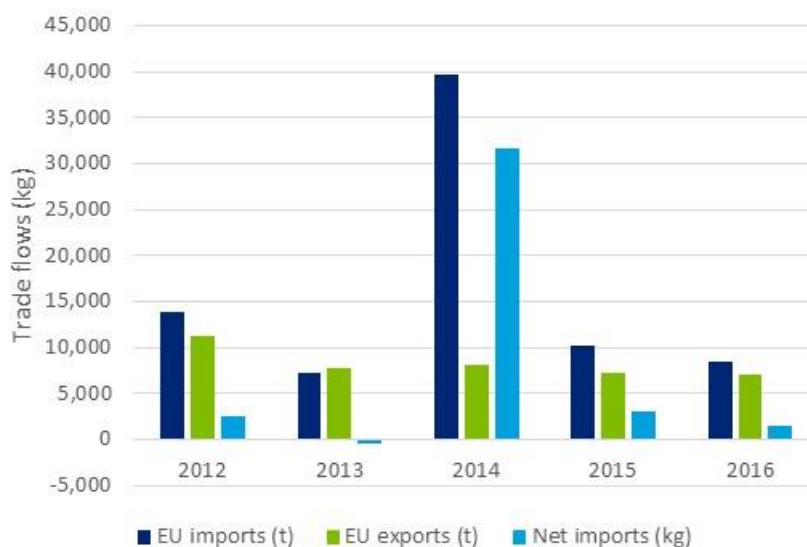
As discussed in section 19.3.1, the PGM are traded in the EU in a variety of forms – as metal in unwrought or powder form, in semi-manufactured forms and various intermediate products and wastes. For palladium, trade data are available for palladium metal in unwrought or powder form (HS code 7110 21), and in semi-manufactured forms (HS 7110 29).

During the period 2012-2016, the EU was a net importer of palladium metal. The EU imported about 46.1 tonnes of palladium in unwrought or powder form on average over the 2012-2016 period, whereas it exported only 0.4 tonnes (see Figure 259). Imports of palladium in unwrought or powder form have increased significantly from 2013 to 2016 by 50%. The primary sources of EU imports of palladium metal were Russia, the United Kingdom, Switzerland, the USA, and South Africa (see Figure 259). The main destination of EU exports for unwrought palladium or in powder form was the US (36% of the total).

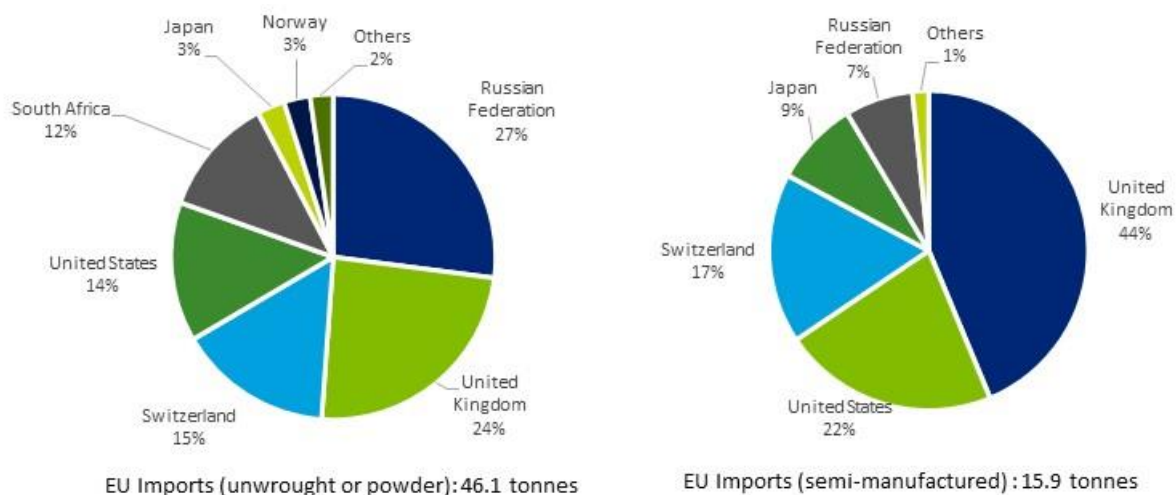


**Figure 259: EU trade flows for palladium in unwrought or powder form (HS 7110 21), 2012–2016. Data from (Eurostat, 2019a)**

Similarly, the EU was a net importer for palladium in semi-manufactured forms as the annual average net imports amounted to 7.6 tonnes over the period 2012-2016. A surge of imports can be noted in Figure 260 for the year 2014, which is due to a particularly high amount of material (about 33 tonnes) imported from the United Kingdom in that year. The main origins of imports for palladium in semi-manufactured forms was the United Kingdom, the United States, and Switzerland (see Figure 261). The annual average EU exports for palladium in semi-manufactured forms reached 8.3 tonnes per annum between 2012 and 2016. The main destinations for these exports were the US (37%), Switzerland (23 %) and the United Kingdom (13%).



**Figure 260: EU trade flows for palladium in semi-manufactured forms (HS 7110 29), 2012-2016. Data from (Eurostat, 2019a)**



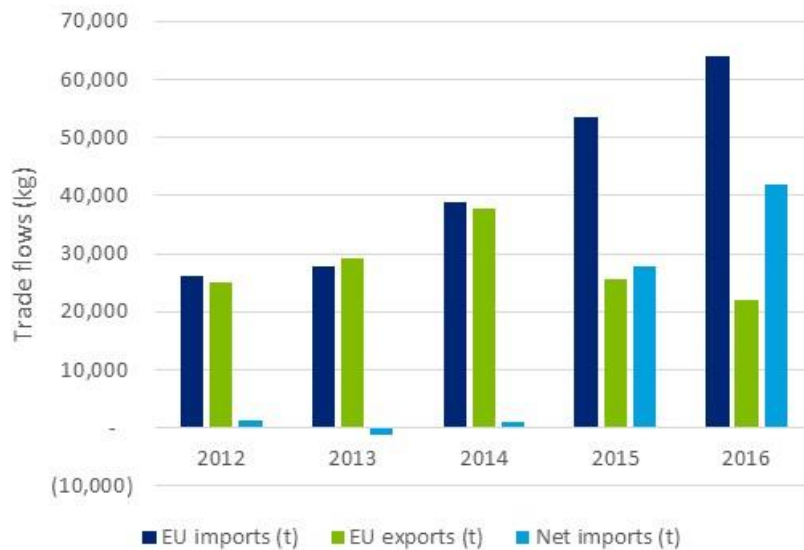
**Figure 261: Origin countries for EU imports of palladium in unwrought or powder form (left), and in semi-manufactured forms (right), average 2012-2016. (Eurostat, 2019a)**

In 2017, there were no export taxes, quotas or export prohibition in place by EU's suppliers for HS 7110 21 "Palladium, unwrought/in powder form" and HS 7110 29 "Palladium, in semi-manufactured forms" (OECD, 2019). The EU and South Africa have a trade agreement in place (European Commission, 2019).

### 19.3.2.3 EU trade of platinum

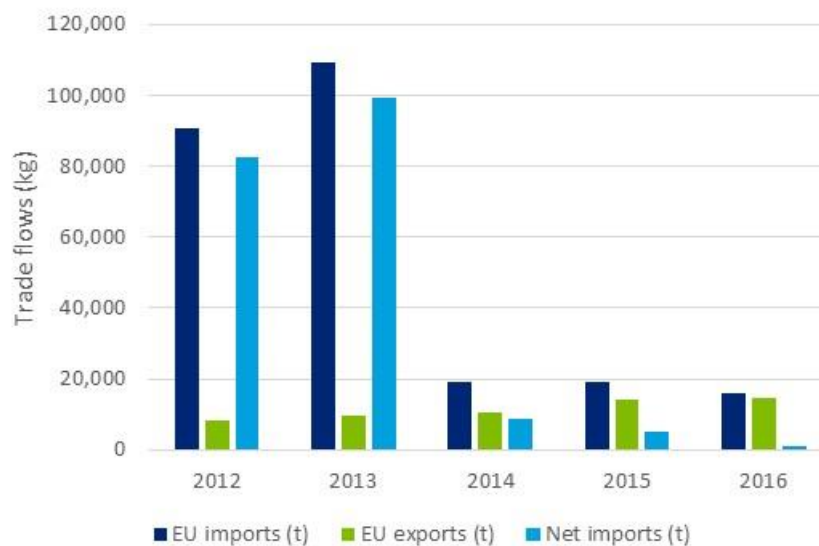
As discussed in section 19.3.1, the PGM are traded in the EU in a variety of forms – as metal in unwrought or powder form, in semi-manufactured forms and various intermediate products and wastes. For platinum, trade data are available for platinum in unwrought or powder form (HS code 7110 11), platinum in semi-manufactured forms (HS 7110 19), platinum waste and scrap (HS code 7112 92), and platinum catalysts in the form of wire cloth or grill (HS code 7115 10).

The EU was a net importer of platinum metal over the period 2012-2016. On average, the EU imported about 42.1 tonnes per year of platinum in unwrought or powder form, while it exported 27.9 tonnes per year. A gradual and significant increase in the amount of imports took place from 2012 to 2016 (see Figure 262). Imports in 2016 surged by about 150% compared to 2012, with South Africa contributing to the higher amount of the increase (one-third of the overall rise). EU imports and exports remained relatively balanced in the period 2012-2014. Nevertheless, a substantial increase in EU net imports took place in 2015 and 2016, due to declining exports. The primary sources of EU imports of platinum metal were South Africa, the United Kingdom, the United States, and Switzerland (see Figure 262). The main destinations of EU exports for unwrought platinum or platinum in powder form were the United Kingdom (33%), the United States (29%), and Switzerland (22%).



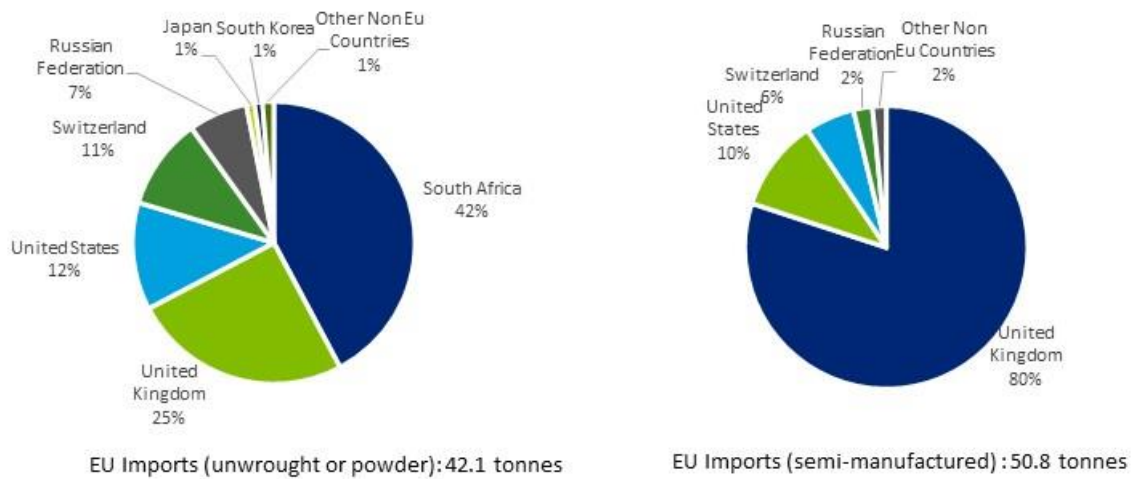
**Figure 262: EU trade flows for platinum in unwrought or powder form (HS 7110 11), 2012–2016. Data from (Eurostat, 2019a)**

Concerning platinum in semi-manufactured forms, the EU was also a net importer over the period 2012-2016 as the annual net imports averaged to 39.3 tonnes (see Figure 263). Imports were particularly high in 2012 and 2013 due to increased amounts received from the United Kingdom (81 tonnes and 100 tonnes, respectively). United Kingdom was the dominant sourcing country for the EU imports of platinum in semi-manufactured forms accounting for 80% of the 50.8 tonnes of total imports (see Figure 264). The average EU exports for platinum in semi-manufactured forms were 11.5 tonnes per annum between 2012 and 2016, and the main destinations were the United States (38%), the United Kingdom (26%), and Switzerland (14%).



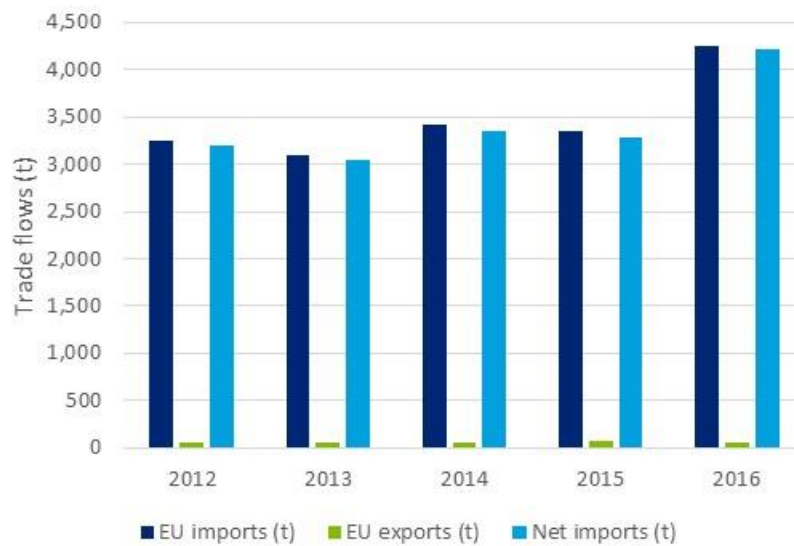
**Figure 263: EU trade flows of platinum in semi-manufactured forms (HS 7110 19), 2012-2016. Data from (Eurostat, 2019a)**



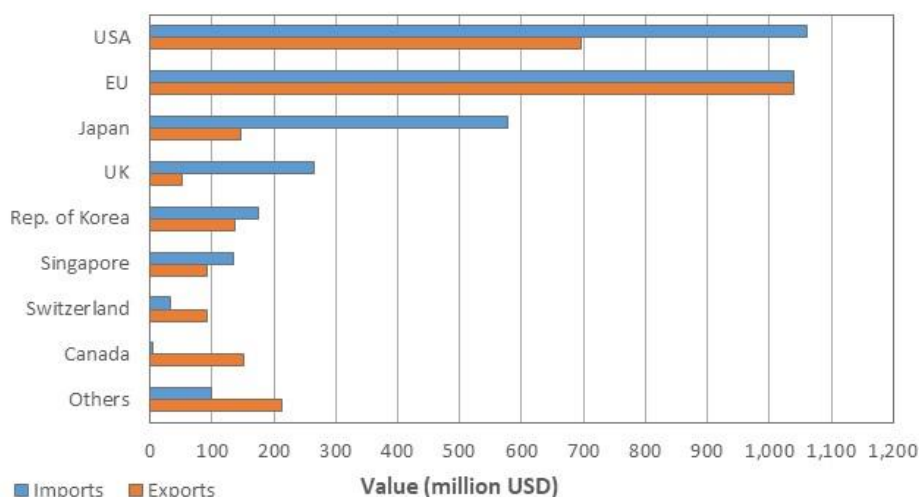


**Figure 264: Origin countries for EU imports of platinum in unwrought or powder form (left), and in semi-manufactured forms (right), average 2012-2016. Data from (Eurostat, 2019a)**

There is also significant international trade of platinum-bearing waste and scrap in the EU Member States. Figure 265 presents the relevant trade flows in terms of volume from 2010 to 2016, and Figure 266 shows the top importers and exporters worldwide of waste and scrap of platinum by value in 2017 (including intra-EU trade). As it is demonstrated by Figure 265, EU-extra imports of waste and scrap of platinum prevail over imports to a large extent.



**Figure 265: EU trade flows of waste and scrap of platinum (HS 7112 92), 2012-2016. Data from (Eurostat, 2019a)**



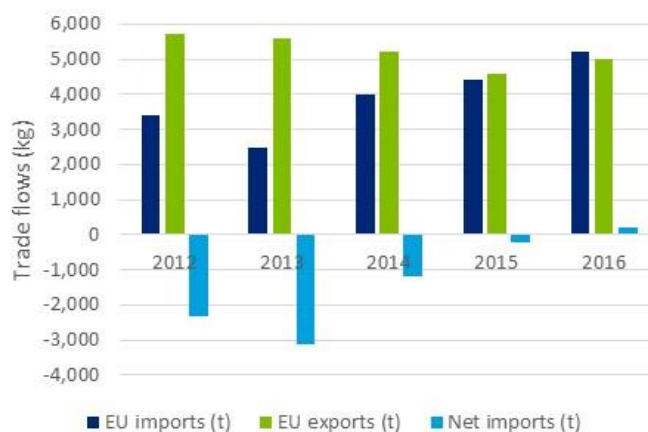
**Figure 266: Global trade of platinum waste and scrap (HS 7112 92) in 2017 by value. Data from (UN Comtrade, 2019)**

In 2017, there were no export taxes, quotas or export prohibition in place imposed by EU's suppliers for HS 7110 11 "Platinum, unwrought/in powder form" and HS 7110 19 "Platinum, in semi-manufactured forms". The EU and South Africa have a trade agreement in place (European Commission, 2019).

#### 19.3.2.4 EU trade of rhodium

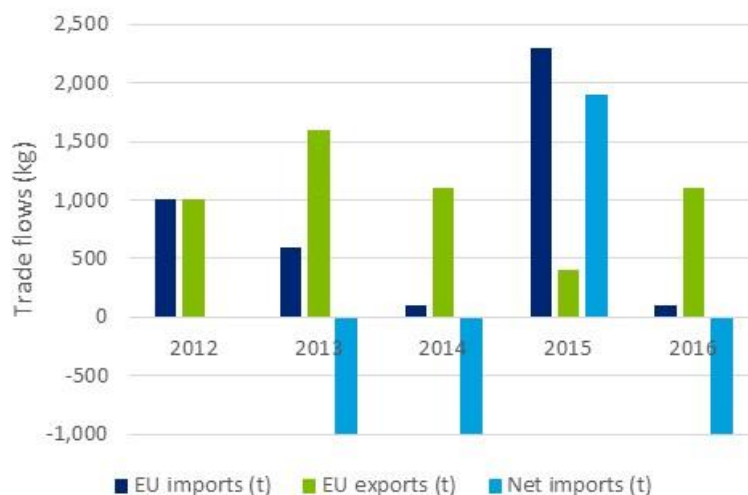
As discussed in section 19.3.1, the PGMs are traded in a variety of forms – as metal in unwrought or powder form, in semi-manufactured forms and various intermediate products and wastes. For rhodium, trade data are available for rhodium metal in unwrought or powder form (HS 7110 31), and in semi-manufactured forms (HS 7110 39). In the years 2012-2016, the EU was a net exporter for both rhodium in unwrought or powder form and rhodium in semi-manufactured forms.

The EU imported on average 3.9 tonnes per year and exported 5.2 tonnes per year of rhodium in unwrought/powder form; thus the net exports averaged to 1.3 tonnes annually. In the period 2012-2014 exports prevailed significantly over imports, whereas in 2014-2015, the trade balance is almost neutral (see Figure 267). South Africa was the predominant source of EU's imports of rhodium in unwrought/powder form, accounting for 45% of the total imports (see Figure 269). The United Kingdom (21%), Russia (17%) and the United States (13%) were also important trade partners.



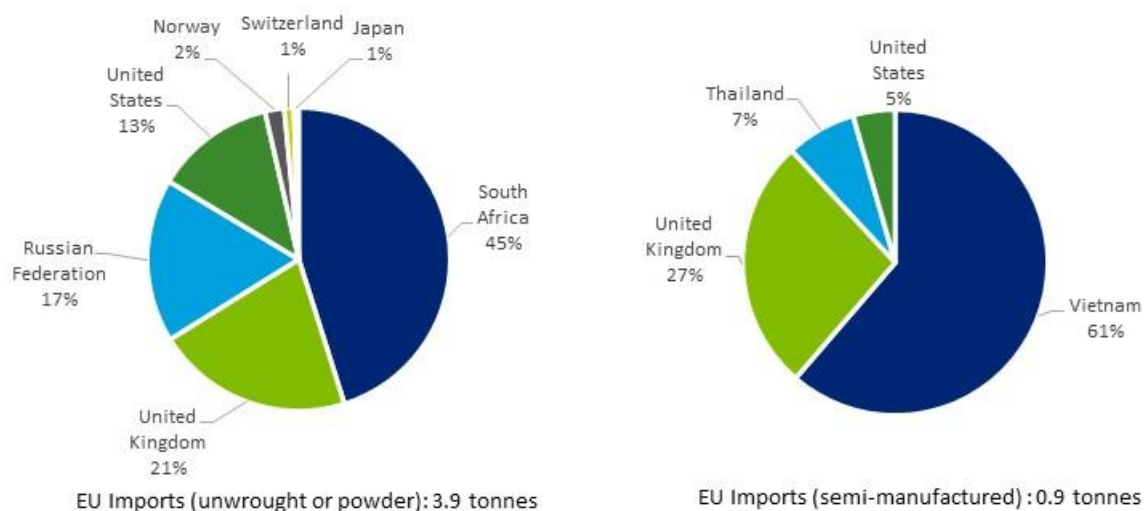
**Figure 267: EU trade flows for rhodium in unwrought or powder form (HS 7110 31), 2012–2016 (Eurostat, 2019a)**

For rhodium in semi-manufactured forms, the annual average imports amounted to 0.8 tonnes and the yearly average exports to one tonne, resulting in average yearly net exports of 0.2 tonnes (with high fluctuations) (see Figure 268). Vietnam was the major source for EU imports of rhodium in semi-manufactured forms, mainly due to a massive import flow in 2015.



**Figure 268: EU trade flows for rhodium in semi-manufactured forms (HS 7110 39), 2012-2016 (Eurostat, 2019a)**

Figure 269 presents the sources of EU imports of rhodium.



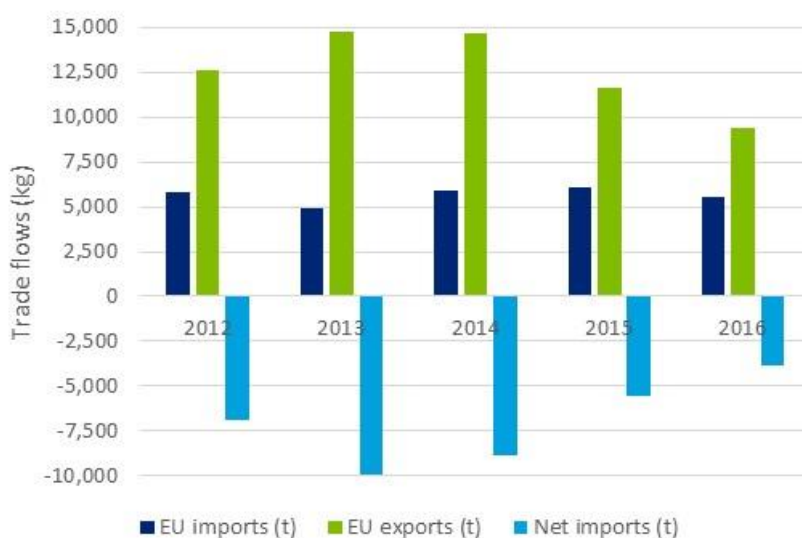
**Figure 269: Origin countries for EU imports of rhodium in unwrought or powder form (left), and in semi-manufactured forms (right), average 2012-2016 (Eurostat, 2019a)**

In 2017, there were no export taxes, quotas or export prohibition in place by EU's suppliers for HS 7210 31 "Rhodium, unwrought/in powder form" and HS 7110 39 "Rhodium, in semi-manufactured forms" (OECD, 2019). The EU and South Africa have a trade agreement in place (European Commission, 2019).

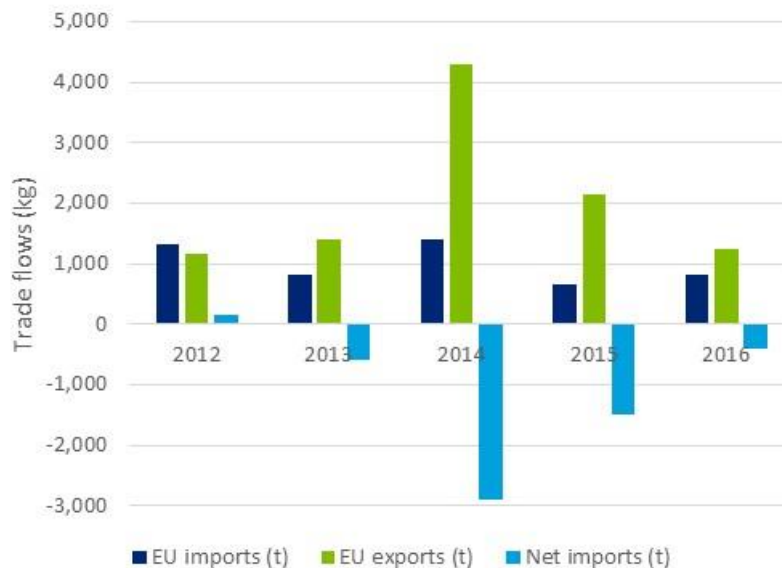
### 19.3.2.5 EU trade of ruthenium

As discussed in section 19.3.1, PGMs are traded in the EU in a variety of forms – as metal in unwrought or powder form, in semi-manufactured forms and various intermediate products and wastes. For ruthenium, trade data were analysed for HS code 7110 41 (which includes iridium, osmium and ruthenium in unwrought or powder form), and for trade code HS 7110 49 (which includes iridium, osmium and ruthenium metal in semi-manufactured forms). The proportion of ruthenium in the EU trade flows was estimated by assuming trade flows for osmium to be negligible small, thus set to zero. In addition, by considering that the disaggregated trade flows for ruthenium and iridium are proportional to their world demand. The relative size of their markets was derived from data published by (Johnson Matthey, 2019a), and has been estimated at 83% ruthenium and 17% iridium, as an average over the 2012-2016 period.

In all years from 2012 to 2016, the EU was a net exporter of ruthenium in unwrought or powder form (see Figure 270). The average annual net exports amounted to 7 tonnes; however, since 2013 the trade balance is declining due to decreasing exports. For ruthenium in semi-manufactured forms the EU was also a net exporter on average in years 2012-2016 (Figure 271). From the the figures, it is concluded that that the EU is a significant world supplier of refined ruthenium; however, it is not possible to determine how much of this metal was derived from primary or secondary sources.



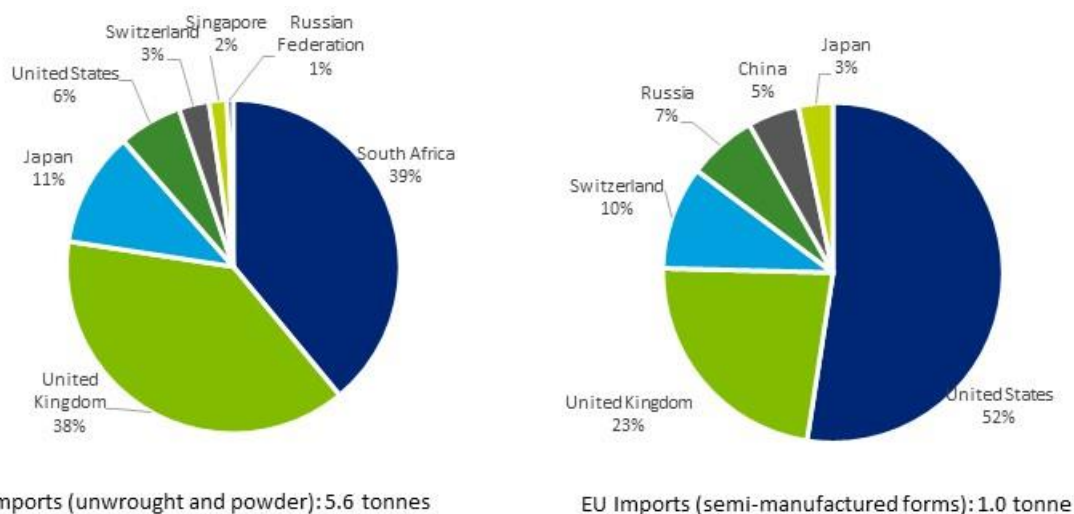
**Figure 270: Estimated EU trade flows for ruthenium in unwrought or powder form. Background data from (Eurostat, 2019a; Johnson Matthey, 2019a)**



**Figure 271: Estimated EU trade flows for ruthenium in semi-manufactured forms, Background data from (Eurostat, 2019a; Johnson Matthey, 2019a)**

The average annual EU imports of ruthenium, in unwrought or powder form, were about 5.6 tonnes between 2012 and 2016. The sources of these imports were South Africa (39%), the United Kingdom (38%), and Japan (11%) (Figure 272). During the same period, the EU exported annually about 12.6 tonnes of ruthenium metal, in unwrought or powder form. Singapore was the top destination of exports (75% of the total), followed by the United States (9%).

The average annual EU imports of ruthenium in semi-manufactured forms were about 1.0 tonne from 2012 to 2016. The United States was the main source (52%), followed by the United Kingdom (23%) and Switzerland (10%) (Figure 272). In the same period, the EU exported annually about 2.1 tonnes of ruthenium in semi-manufactured forms. Turkey (48%) was the major destination of EU exports, followed by Brazil and Singapore (13% each).



**Figure 272 : Origin countries for EU imports of ruthenium metal in unwrought or powder form (left), and in semi-manufactured forms (right), average 2012-2016. Background data from (Eurostat, 2019a; Johnson Matthey, 2019a).**

No export taxes, quotas or export prohibition are reported to be in place by EU's suppliers for HS 7110 41 "Iridium, osmium & ruthenium, unwrought or in powder form" and HS 7110 49 "Iridium, osmium & ruthenium, in semi-manufactured forms". The EU and South Africa have a trade agreement in place (European Commission, 2019).

## **19.4 Prices and price volatility**

---

### **19.4.1 Prices and price volatility of platinum group metals in general**

PGM prices are high due to the limited availability in nature and in the market. Prices are sensitive to volatility because of a small buffering stock-in-use in society and low flexibility for accommodating rapid changes in demand (Sverdrup and Ragnarsdottir, 2016).

PGM are bought and sold in various ways. Platinum and palladium are typically exchange-traded with several daily market prices quoted for the pure (min. 99.9%) metals in US\$ per troy ounce. For example, the London Metal Exchange (LME) delivers daily prices for platinum and palladium on behalf of the London Bullion Market Association. Johnson Matthey also publishes daily prices based on the company's quoted prices for its customers of wholesale quantities of platinum group metals set by its trading desks in the U.S., Hong Kong and the UK. The price is for the metal in sponge form with minimum purities of 99.95% for platinum and palladium, and 99.9% for rhodium, iridium and ruthenium. Platinum and palladium are also traded over-the-counter. Other platinum group metals are more commonly traded through long-term supply contracts and individual trades between large consumers and suppliers and trading houses (European Commission, 2014).

The evolution of prices for each PGM is presented in the individual PGM factsheets. In general, the price development of the PGM used in autocatalysts is the result of the interaction between market, catalytic technology and availability of raw materials (Hagelüken, 2019). Moreover, the price volatility observed for the PGM is due to various events that could affect global supply and demand. Some are associated with government policies and legislation such as the widespread adoption of catalytic converters in the mid-1970s which led to a surge in PGM demand (Hagelüken, 2019). Others are related to the changing global economic conditions such as the worldwide recession of 2008. Other events are related to supply disruption in mineral production such as miners' strikes in South Africa (1986, 2011, and 2012), and the power supply disruption in South Africa in 2008 when the South African mining industry briefly shut down almost all its operations (Zientek et al., 2017).

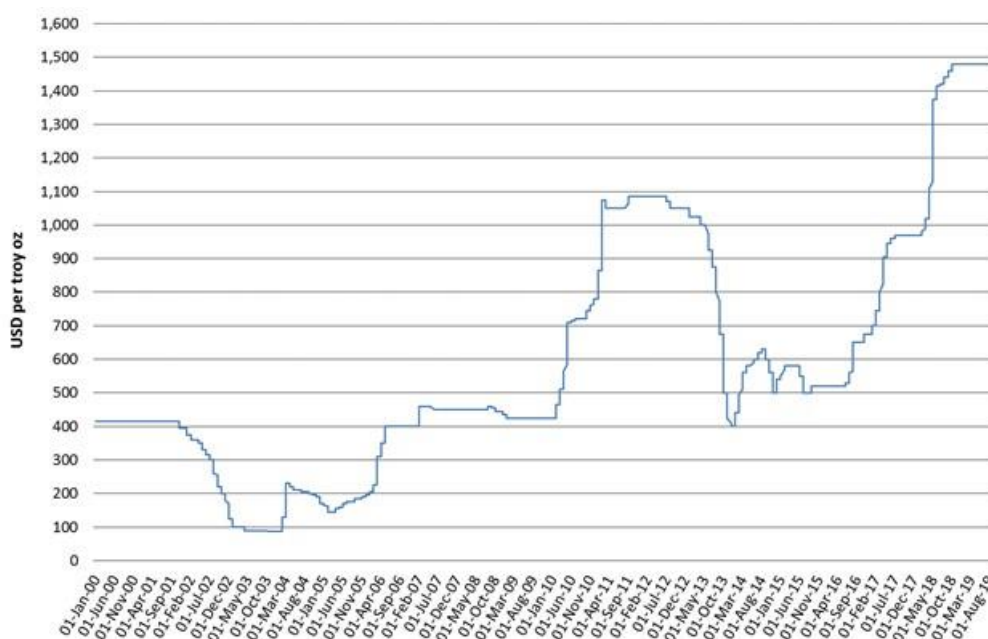
### **19.4.2 Prices and price volatility of individual platinum group metals**

#### **19.4.2.1 Prices and price volatility of iridium**

Unlike platinum and palladium, iridium is not traded on the major metal exchanges. Iridium is generally sold through long-term supply contracts between fabricators and mines. Johnson Matthey is the main fixer of the iridium price publishing quoted prices set by the company's trading desks in the United States, Hong Kong and the United Kingdom for wholesale quantities of platinum group metals. The price is for the metal in sponge form with a minimum purity of 99.9% iridium (European Commission, 2017).

The price of iridium has experienced considerable volatility in recent years in response to changing industrial demand. In the 1990s, iridium price had a tenfold increase from US\$60 per troy ounce in 1996 to US\$575 per troy ounce in 2019, as it was first used in 1996 for iridium-coated catalytic converters in Japan (Hagelüken, 2019). Nevertheless, the subsequent price evolution is not related to autocatalysts. Over the first decade of the 2000s, the price varied between about US\$100 and US\$400 per troy ounce. However, in early 2010, it began to rise rapidly, peaking in late 2011 at approximately US\$1,085 per troy ounce. This sharp increase can be attributed chiefly to a rapid and significant expansion of demand for iridium crucibles by the electrical sector (European Commission, 2017). However, the high level of demand from the electronics industry was not sustained,

and the price fell back sharply to about US\$400 per troy ounce in late 2013. Reduced demand from the chlor-alkali industry in China also contributed to the falling price in this period (European Commission, 2017). Since the second half of 2016, the iridium price has risen sharply from US\$520 to US\$1,480 per troy ounce in October 2018 at an all-time high (a price gain of 185 %). The price rise is attributed to supply fluctuations of refined metal, increased industrial demand in 2017 for crucibles from the electrical sector and for the coating of anodes in the electrochemical sector, as well as due to strategic purchasing in Asia in 2016-2017; in 2018 the price rose sharply despite lower demand in comparison to 2017 (Johnson Matthey, 2018); Johnson Matthey, 2019a). Iridium’s price has remained stable to this record level until September 2019 (see Figure 273), reflecting a modest improvement in market liquidity, probably due to some additional recycling activity in the chemicals sector and growth in refined output (Johnson Matthey, 2019a).



**Figure 273. Iridium price trend, January 2000 – September 2019, Johnson Matthey quoted daily prices (US\$/oz<sup>190</sup>), sponge, min. 99.9%, London. Data from (Johnson Matthey, 2019d)**

#### 19.4.2.2 Prices and price volatility of palladium

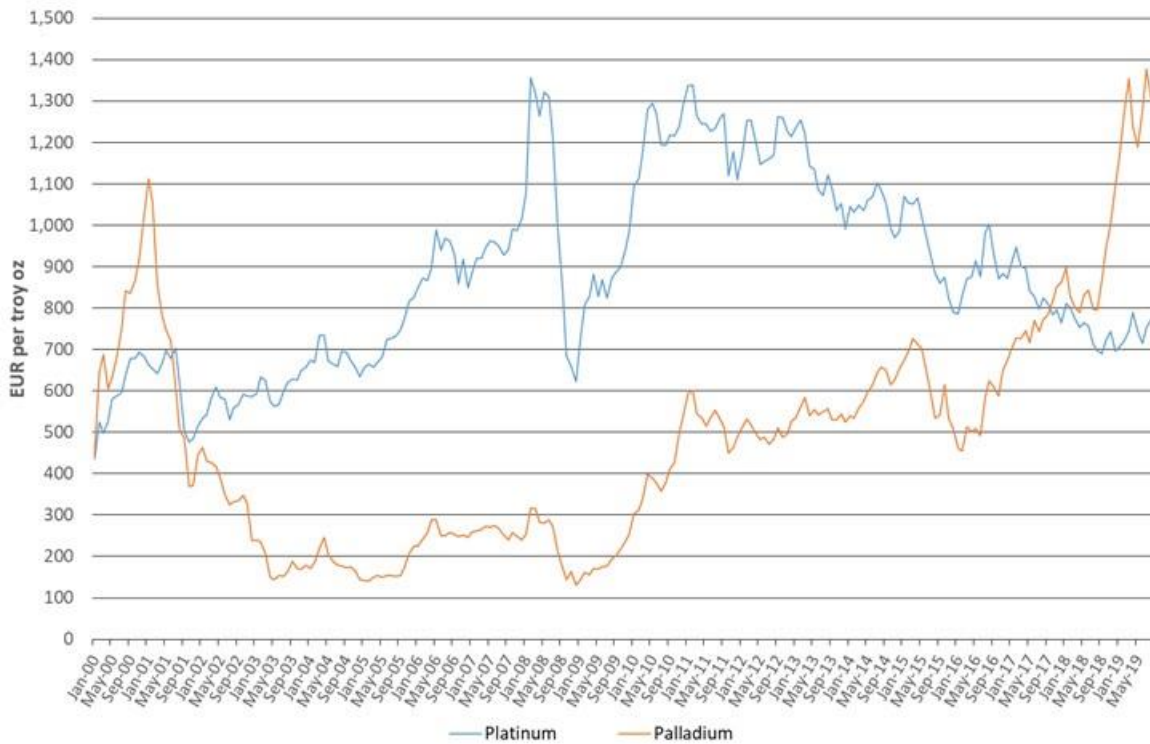
Palladium is typically exchange-traded. Pure palladium (minimum 99.95 %) prices are quoted daily in US dollars per troy ounce in a number of international exchange markets. It is also traded through London on a 24-hour basis in over-the-counter (OTC) transactions between miners, central banks, governments, fabricators, investors, hedge funds and refiners. From December 2014, a new benchmark price is set twice daily, called the “London Metal Bullion Association (LBMA) Palladium Price”, via an auction process taking place in the OTC market in London (LBMA, 2019). The prices are administered and distributed by the London Metals Exchange (LME) via a custom-built electronic auction platform. The new reference prices replace the data of the London Platinum Fixing Company (LPPFCL). In the spot market, palladium is sold for cash and immediate delivery in sponge, plate or ingot form. Palladium is also traded through long-term supply contracts between fabricators and miners.

<sup>190</sup> 1 troy ounce (oz t) = 31.10348 g



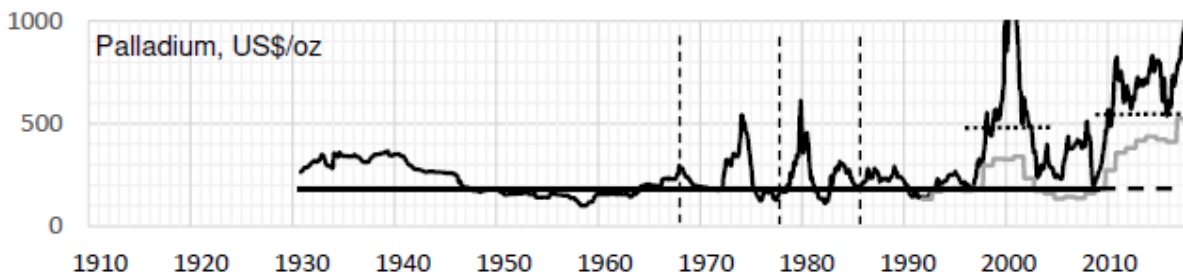
The price of palladium has fluctuated considerably in recent years. From 1995 to 2001 palladium dominated the autocatalysts sector as it substituted platinum in gasoline vehicles (e.g. in the classical European 3-way catalyst with a Pt/Rh ratio of 5:1) driven by technical developments in catalyst technology and improved fuel qualities (Hagelüken, 2019). At the same time, Russia temporarily blocked palladium exports in 1999 and 2000 (Zientek et al., 2017). The result of strong demand and supply disruption was that palladium's price rose sharply in the late 1990s reaching its peak in January 2001 at around €1,100 per troy ounce, and palladium became more expensive than platinum. However, this trend was not sustained as high prices brought about substitution by platinum (Hagelüken, 2019), which in combination with increasing supply (Schmidt, 2015), made the palladium's price to fall steeply at levels as low as €150 per troy ounce in May 2003. A new substitution cycle was triggered again in 2008 when the price differential between the two PGM became very high (Hagelüken, 2019). After the global economic recession in 2008, palladium's price had a continually rising trend, with short-term drops during the second semester of 2011 and 2015. Since the beginning of 2016, palladium's price has surged dramatically, and in October 2017 surpassed platinum's price for the first time since 2001. Palladium's price climbed at a record level of €1,455 per troy ounce in September 2019, widening considerably the price premium to platinum (see Figure 274).

According to Johnson Matthey's data, palladium's market is in deficit since 2011 (see Figure 274), and this reflected in poor liquidity and higher prices (Johnson Matthey, 2017; Johnson Matthey, 2018). Demand for palladium in autocatalysts is experiencing a steady increase since 2009, and surged to an all-time high record of 271 tonnes in 2018, more than doubled in comparison to 2009 (126 tonnes). In contrast, platinum demand for autocatalysts in the same period increased from 68 tonnes in 2009 to 99 tonnes in 2018. The diesel emissions scandal in Europe is considered a factor that resulted in an increasing trend towards gasoline vehicles, thus in higher palladium demand for autocatalysts compared to platinum, as well as the partial substitution of platinum by palladium in diesel catalysts (DERA, 2017; Hagelüken, 2019).



**Figure 274: Palladium and Platinum (99.95%) price trend from January 2000 to August 2019, LBMA afternoon monthly average, in warehouse (€/oz t<sup>191</sup>). Data from (LPPM, 2019)**

The long-term prices of palladium are shown in Figure 275. The price curve shows real prices.



**Figure 275: Palladium prices in US\$ per troy ounce. Vertical dashed line indicate breaks in price specification. (Buchholz et al. 2019)**

### 19.4.2.3 Prices and price volatility of platinum

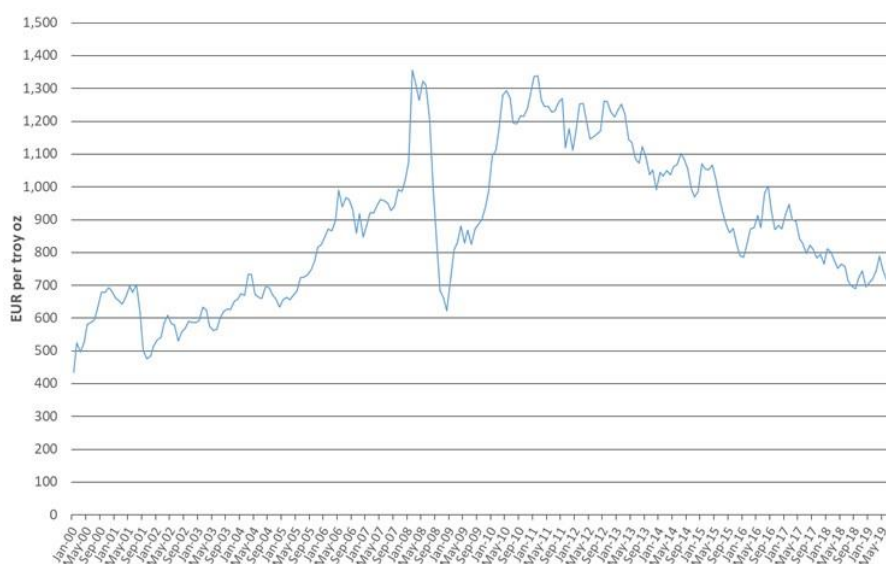
Platinum is typically exchange-traded in international markets with a number of daily market prices (e.g. the London Platinum and Palladium Market and the Johnson Matthey base price) quoted for the pure metal (minimum 99.95 %) in US dollars per troy ounce. Furthermore, platinum is also traded through London on a 24-hour basis in over-the-counter (OTC) transactions between miners, central banks, governments, fabricators, investors, hedge funds and refiners. From December 2014, a new benchmark price is determined twice daily, called the "London Metal Bullion Association (LMBA) Platinum Price", via an auction process taking place in the OTC market in London. The prices are

<sup>191</sup> 1 troy ounce (oz t) = 31.10348 g

administered and distributed by the London Metals Exchange (LME) via a custom-built electronic auction platform. The new reference prices replace the data of the London Platinum Fixing Company (LPPFCL). In the spot market, platinum is sold for cash and immediate delivery in sponge, plate or ingot form. Platinum is also traded through long-term supply contracts between fabricators and miners.

The price of platinum has experienced a high degree of volatility in recent years. After a long period of relative stability during the 1990s at price levels of around US\$400 per troy ounce (Hagelüken, 2019), platinum's price demonstrated an upward trend in the years after 2000, peaking at an all-time record high of about €1,360 per troy ounce in February 2008, following the widespread use of platinum in exhaust catalysts for diesel-fueled vehicles as well the expectations for fuel cell technology development. However, at the onset of the global economic recession in 2008, the price fell sharply within a few months to around €620 per troy ounce in December 2008. With the recovery of the global economy, the price of platinum increased as a result of increased demand, supply shortages and speculation by investors, reaching a peak of about €1,340 per troy ounce in February 2011 (Schmidt, 2015). Since then, platinum's price has been volatile following a downward path. In October 2017 platinum's price became lower than palladium's price for the first time since 2001 (see Palladium factsheet), and in August 2018 the monthly average price was about €700 per troy ounce, the lowest since December 2008.

According to the market data of supply and demand published by Johnson Matthey, the sustained declining trend cannot be attributed to market surplus as the platinum market remained in an overall deficit from 2012 to 2016, moving to a modest surplus only in 2017 (see Figure 276). The diesel crisis and the resulting trend towards gasoline vehicles, as well as partial substitution of platinum by palladium in diesel catalysts, affected the increased demand for palladium in comparison to platinum (DERA, 2017).



**Figure 276: Platinum (99.95%) price trend from January 2000 to August 2019, LBMA afternoon monthly average, in warehouse (€/oz t192). Data from (LPPM, 2019)**

<sup>192</sup> 1 troy ounce (oz t) = 31.10348 g

The long-term prices of platinum are shown in Figure 277



The price curve shows real prices.

**Figure 277: Platinum prices in US\$ per troy ounce. Vertical dashed line indicate breaks in price specification.(Buchholz *et al.* 2019)**

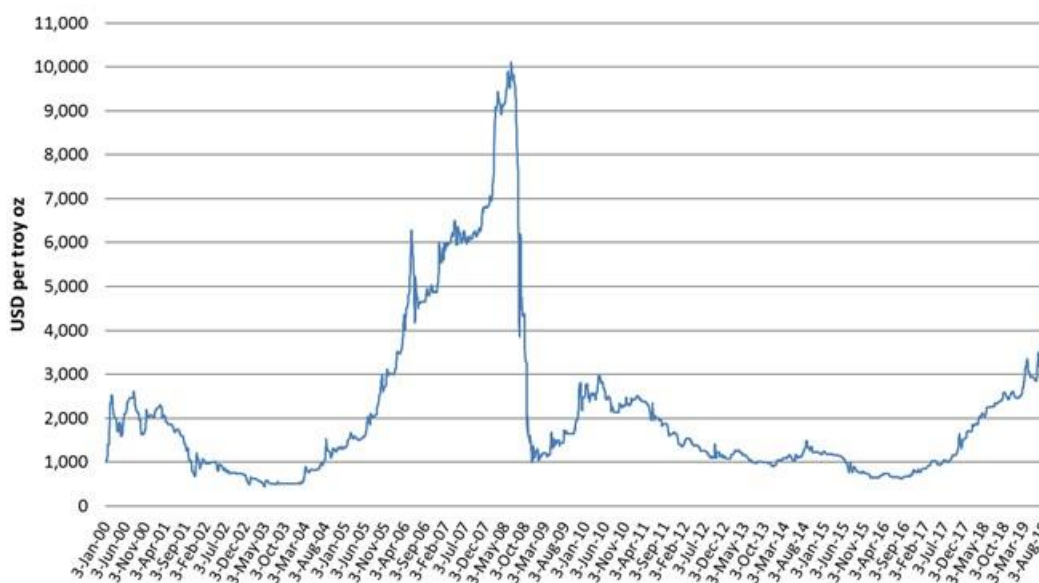
#### 19.4.2.4 Prices and price volatility of rhodium

Unlike platinum and palladium, rhodium is not traded on the major metal exchanges. Rhodium is generally sold through long-term supply contracts between fabricators and mines. Johnson Matthey is the main fixer of the rhodium price, publishing daily prices from its trading desks in the United States, Hong Kong and the United Kingdom. The price is for the metal in sponge form with a minimum purity of 99.9% rhodium (European Commission, 2017).

Rhodium has experienced extreme price volatility in recent years (see Figure 278). Prices increased in the late 1990s, reaching about US\$2,600 per troy ounce in mid-2000 (Zientek *et al.*, 2017). In 2003, the average price for rhodium was only US\$530 per troy ounce. In response to the rapidly growing demand for autocatalysts, especially in Asian markets (Zientek *et al.*, 2017), the price rose steadily from 2004 onwards, peaking at a particularly high rate of more than US\$10,000 per troy ounce in July 2008. However, with the onset of the global economic recession and decreasing demand, it fell sharply by 90% to about US\$1,000 per troy ounce by the end of 2008. Following a short recovery in 2010 up to US\$3,000 per troy ounce, rhodium's price followed a general downward trend. Between 2013 and the third quarter of 2017, rhodium's price fluctuated between US\$640 per troy ounce and US\$1260 per troy ounce, as a result of weak industrial demand and improved supply situation (European Commission, 2017), as well as due to the spread of diesel vehicles which do not require rhodium in diesel oxidation catalysts (DOC) and particulate filters (DPF) (Hagelüken, 2019).

Since mid-2017, the rhodium price has been rising steadily, and almost increased by eight times to an eleven-year high of around US\$5,000 per troy ounce in September 2019, well above gold and other PGMs; notably, from May 2019 to September 2019, the monthly average price of rhodium surged by 67% from about US\$3,000 per ounce to nearly US\$4,900 per ounce. According to Johnson Matthey, the price increase in 2017 is not attributed to supply shortage or increased demand by a specific industrial sector, but speculative and strategic purchasing of rhodium, especially in Asia, which had a significant impact in metal availability (Johnson Matthey, 2018). In 2018, the rhodium price continued climbing steadily by 45%, reaching an eight-year high of US\$2,600 per ounce in December 2018, despite a market overall surplus suggesting that market participants and perhaps industrial consumers (automotive and industrial companies) purchased and held rhodium in anticipation of future demand growth (Johnson Matthey, 2019a). Within 2019, rhodium price has been rising steeply, reaching US\$5,000 per ounce in September 2019, the highest since September 2008, and almost doubled in comparison to December 2018. It is noted that the impressive growth in rhodium price in 2019 coincides with a forecasted

increasing demand for autocatalysts due to tighter emissions legislation and more stringent testing (see section 1.2.1.2).



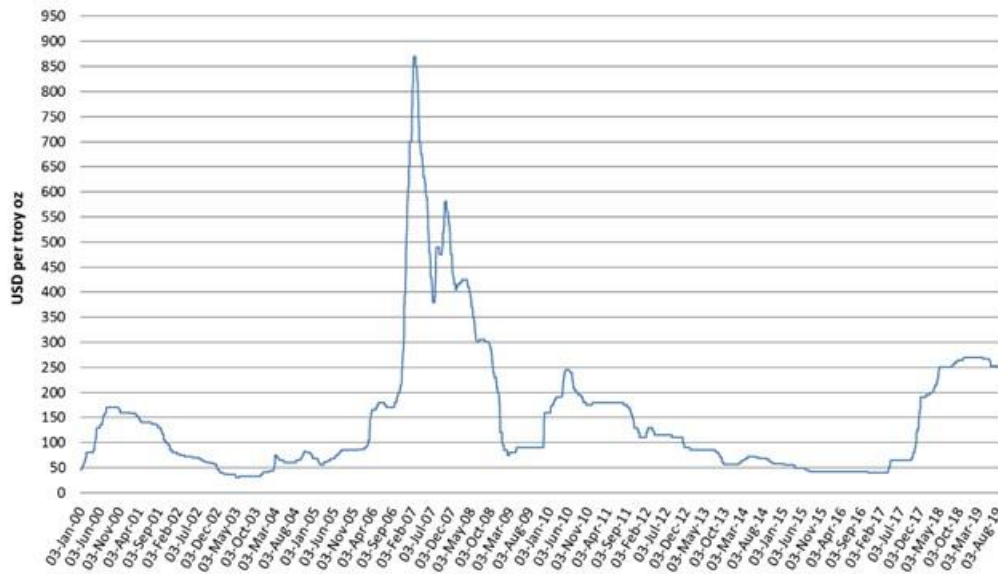
**Figure 278. Rhodium price trend, January 2000-September 2019, Johnson Matthey quoted daily prices (US\$/oz t<sup>193</sup>), sponge, min. 99.9%, London. Data from (Johnson Matthey, 2019d)**

#### 19.4.2.5 Prices and price volatility of ruthenium

Unlike platinum and palladium, ruthenium is not traded on the major metal exchanges. Ruthenium is generally sold through long-term supply contracts between fabricators and mines. Johnson Matthey is the main fixer of the ruthenium price, publishing daily prices from its trading desks in the United States, Hong Kong and the United Kingdom quoted for customers of wholesale quantities of platinum group metals. The price is for the metal in sponge form with a minimum purity of 99.9% ruthenium (European Commission, 2017).

The price of ruthenium has experienced significant fluctuations in recent years (Figure 279). From levels between US\$30-40 per troy ounce in 2003, the price followed an upward trend peaking at about US\$850 per troy ounce in February 2007, as a result of increased ruthenium usage in electronics, especially in computer hard disk drives (Zientek et al., 2017). However, with the onset of the global economic recession, it fell back to US\$75 per troy ounce in early 2009. Following a brief recovery in 2010, the price has further declined to US\$40 per troy ounce at the beginning of 2017, which is the onset of a constant rise to the level of US\$270 per troy ounce at the end of 2018, reaching a ten-year high. According to (Johnson Matthey, 2018), the rise of ruthenium price in 2017 is attributed to steady industrial demand and strategic purchasing in Asia, while in 2018 the factors contributing to price increase were again strategic purchasing in Asia and fluctuations in supply from primary and secondary refiners, even though demand was lower in comparison to 2017 (Johnson Matthey, 2019a). From mid-2018, ruthenium prices have stabilised (Figure 279) reflecting a modest improvement in market liquidity, probably due to some additional recycling activity in the chemicals sector and an improvement in refined output (Johnson Matthey, 2019a).

<sup>193</sup> 1 troy ounce (oz t) = 31.10348 g



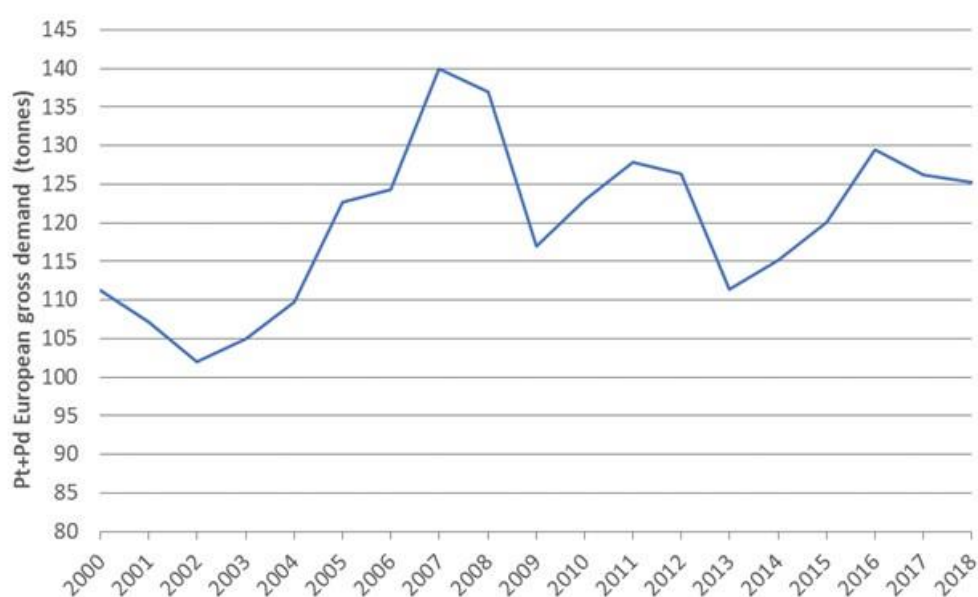
**Figure 279. Ruthenium price trend, January 2000 – September 2019, Johnson Matthey quoted daily prices (US\$/oz t<sup>194</sup>), sponge, min. 99.9%, London. Data from (Johnson Matthey, 2019d)**

<sup>194</sup> 1 troy ounce (oz t) = 31.10348 g

## 19.5 Demand

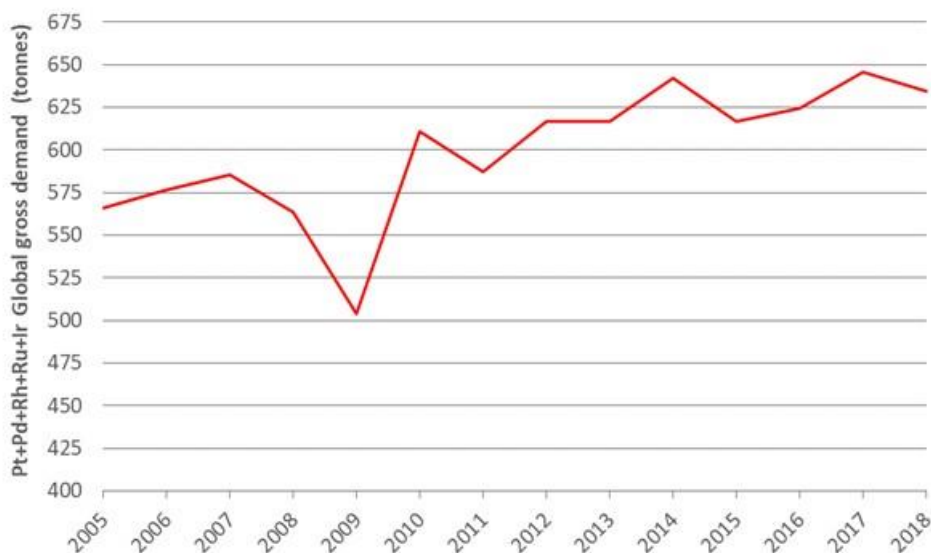
### 19.5.1 EU demand and consumption

Detailed regional demand data is available for platinum and palladium, as compiled by Johnson Matthey. Figure 280 below presents the evolution of European gross demand<sup>195</sup> for platinum and palladium. In 2018, the European demand for platinum and palladium was 125 tonnes, accounting for about 23% of the worldwide consumption (562 tonnes) for these two PGMs (Johnson Matthey, 2019a); the majority (83%) was consumed in autocatalysts. The total world demand for PGMs amounted to approximately 635 tonnes in 2018 (see Figure 280). In the last five years, the global PGM demand ranged from 617 in 2015 to 646 tonnes in 2017, which was the all-time record at this point in time.



**Figure 280: Gross demand in Europe for PGM (platinum+palladium) from 2000 to 2018, Background data from (Johnson Matthey, 2019a) (2014-2018), (Johnson Matthey, 2018) (2013), and (Johnson Matthey, 2014) (2005-2012).**

<sup>195</sup> Gross demand is the sum of manufacturer demand for metal in that application and any changes in unrefined metal stocks.



**Figure 281: Global total gross demand for PGMs (platinum+palladium+rhodium+ruthenium+iridium) from 2005 to 2018. Background data from (Johnson Matthey, 2019a) (2014-2018), (Johnson Matthey, 2018) (2013), and (Johnson Matthey, 2014) (2005-2012).**

Information on consumption for each platinum-group metal is provided in sections 19.5.1.1 – 19.5.1.5.

#### **19.5.1.1 EU demand and consumption of iridium**

Given the diversity of forms in which iridium is traded, the limited scope of trade data specific to iridium and the absence of any distinction between iridium metal derived from primary and secondary source materials, it is not possible to determine a single reliable figure for EU consumption of iridium. The import reliance is 100% for iridium supplied from primary sources.

Gross global demand for iridium in 2018 was 7.5 tonnes (Johnson Matthey, 2019a). In 2016, iridium demand in Europe amounted to approximately 0.9 tonnes, which was about 14% of global demand (Johnson Matthey, unpublished data in European Commission (2017)).

#### **19.5.1.2 EU demand and consumption of palladium**

Given the diversity of forms in which palladium is traded, the lack of production statistics for refined palladium in the EU, and the absence in trade statistics of distinction between platinum derived from primary and secondary sources, it was not possible to determine a single reliable figure for the overall EU consumption of palladium.

The EU apparent consumption of palladium metal in unwrought or in powder form is estimated at 46.5 tonnes per year, as an average over the period 2012-2016. Net imports represent 45.7 tonnes per year, and the domestic production from primary sources (0.8 tonnes per year) the remainder (assuming that it was refined to palladium metal domestically). Based on these figures, the net import reliance as a percentage of apparent consumption for refined palladium in unwrought or in powder form is 98%. The consumption from metal produced domestically from secondary sources is not accounted for in these figures, in other words, the actual EU import reliance for palladium metal in unwrought/powder form is expected to be lower.



According to background data published by Johnson Matthey (Johnson Matthey, 2019), the average annual European demand for palladium, for all uses except investment, was 59 tonnes in the period 2012-2016. In 2018, palladium demand in Europe surged to 68.3 tonnes, and the majority (86%) was used in autocatalysts. Electronics (4%) and manufacture of chemicals (4%) were the second and third-ranked applications, respectively. Investment items contributed to the European demand with 4.4 tonnes in 2018 (i.e. recycling or sales). In the last five years, the European demand for palladium represents a share of between 17% and 20% of the global demand (Johnson Matthey, 2019).

#### **19.5.1.3 EU demand and consumption of platinum**

Given the diversity of forms in which platinum is traded, the absence of production statistics for refined platinum in the EU, and the absence in trade statistics of distinction between platinum derived from primary and secondary sources, it was not possible to determine a single reliable figure for the overall EU consumption of platinum.

The EU apparent consumption of platinum metal in unwrought or in powder form is estimated at 15.1 tonnes per year, as an average over the period 2012-2016. Net imports represent 14.1 tonnes per year, and the domestic production from primary sources of about one tonne made up the remainder (assuming that it was refined to platinum metal domestically). Based on these figures, the net import reliance as a percentage of apparent consumption for refined palladium in unwrought or in powder form is 94%. However, it has to be noted that the consumption related to the significant EU production from secondary sources is not accounted for in the above figures.

According to background data published by Johnson Matthey (Johnson Matthey, 2019b), the average annual European demand for platinum, for all uses except investment, was 63.7 tonnes in the period 2012-2016. In 2018, platinum demand in Europe amounted to 64.5 tonnes, and the majority (71%) was used in autocatalysts. Jewellery (9%) and chemicals manufacture (6%) were the second and third most important applications, respectively. Investment items contributed to the European platinum demand with 3.2 tonnes in 2018 (i.e. recycling or sales). In the last five years, the European demand for platinum represents a share of between 24% and 30% of the total global demand.

#### **19.5.1.4 EU demand and consumption of rhodium**

Given the diversity of forms in which rhodium is traded, and the absence of production statistics for refined rhodium production in the EU, it was not possible to determine a single reliable figure for the EU consumption of rhodium. According to data provided by Eurostat, the EU appears to be a net exporter of rhodium for rhodium in unwrought or in powder form, as well as in rhodium in semi-manufactured forms.

Gross global demand for rhodium in 2018 was 31.8 tonnes (Johnson Matthey, 2019a). In 2015, rhodium demand in Europe amounted to approximately 5 tonnes, which was about 16% of global demand, and the majority was used in autocatalysts (Johnson Matthey unpublished data in European Commission (2017)).

#### **19.5.1.5 EU demand and consumption of ruthenium**

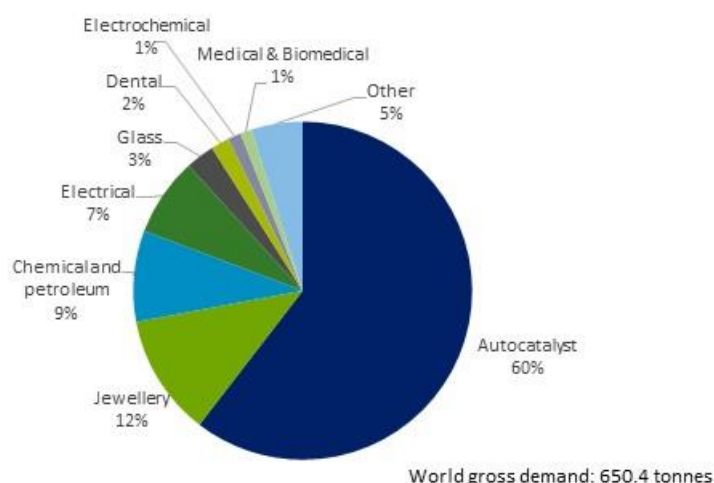
Given the diversity of forms in which ruthenium is traded, the limited scope of trade data specific to ruthenium and the absence of any distinction between ruthenium metal derived from primary and secondary source materials, it is not possible to determine a single reliable figure for EU consumption of ruthenium. The import reliance is 100% for ruthenium supplied from primary sources.

Gross global demand for ruthenium in 2018 was 33.5 tonnes (Johnson Matthey, 2019a). In 2016, ruthenium demand in Europe amounted to approximately 2.5 tonnes, which was about 8% of global demand, mainly used in industrial applications (Johnson Matthey unpublished data in European Commission (2017)).

## 19.5.2 Uses and end uses

### 19.5.2.1 Uses and End Uses of PGMs in general

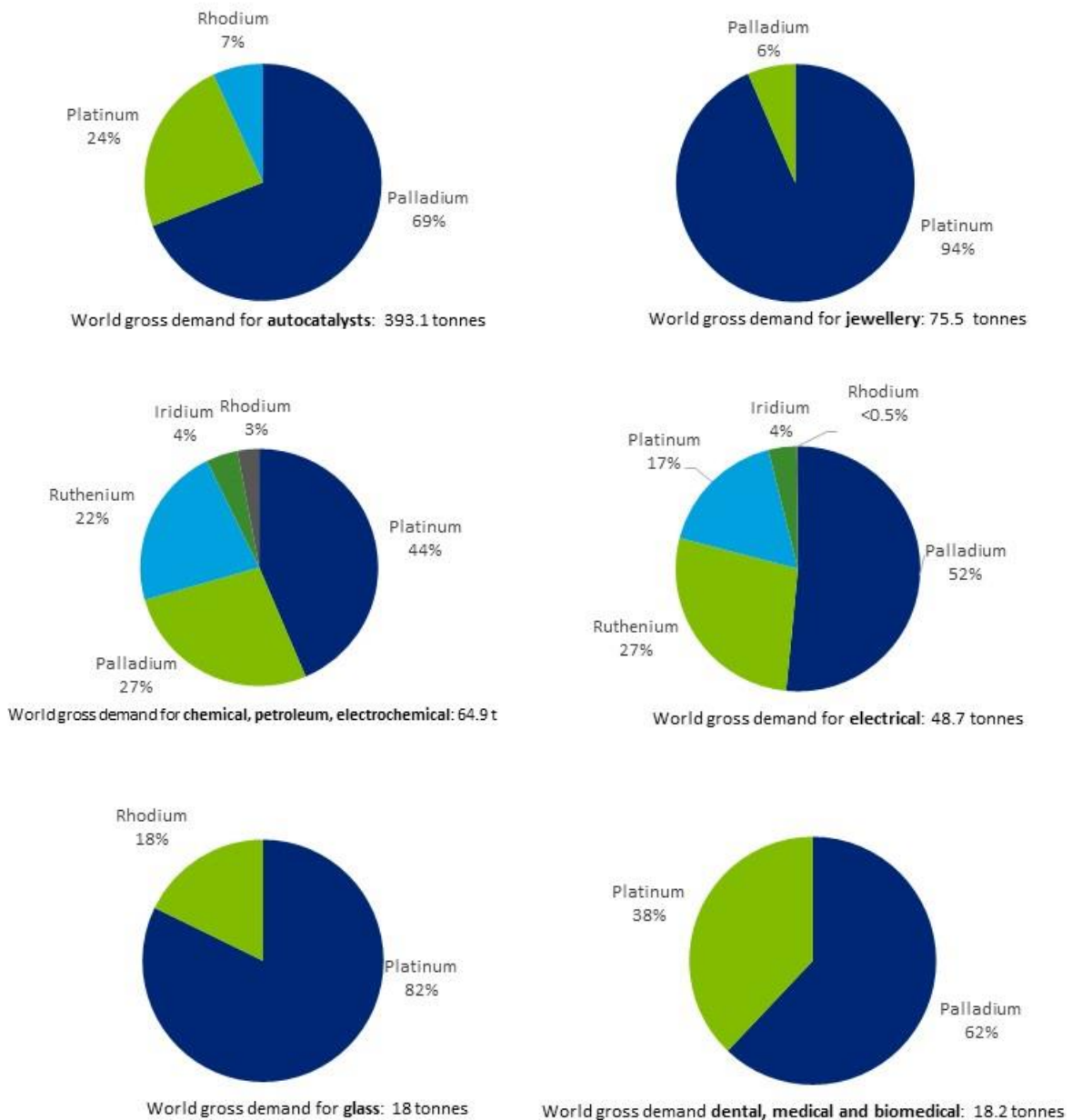
Because of their unique properties, PGMs are fundamental components in a broad range of modern technologies. All the PGMs, commonly in combination with one another or with other metals, can act as catalysts which are exploited in a wide range of applications. The most significant application across the group is associated with automotive catalysts for emissions control. Other important uses accounting for smaller proportions are jewellery, catalysts for chemical processes, and electronic/electrical applications. It is also worth noting that the PGMs are used in very small quantities in the various applications; for instance, the average PGM loading for a EURO 5 light-duty diesel catalyst system is 7-8 grams, whereas the catalyst system contains 2-3 grams in a EURO 5 light-duty gasoline vehicle (IPA, 2015c). An overview of PGM demand by end-use sector is given in Figure 282.



**Figure 282: Global gross demand<sup>196</sup> for PGMs (platinum+palladium+rhodium+ruthenium+iridium) by end uses in 2018. Background data from (Johnson Matthey, 2019a)**

Given the different properties of each PGM, many applications are specific to individual PGMs. Figure 283 presents the structure of PGM demand per application. The demand for each metal of the platinum group by application is presented in the specific PGM factsheet, where also further information is provided.

<sup>196</sup> Investment is not included given that the global gross demand has been negative in 2018, i.e. -15.7 tonnes



**Figure 283: PGM global demand by sector and material in 2018. Background data from (Johnson Matthey, 2019a)**

A short presentation of the PGM applications is given below (European Commission, 2014; European Commission, 2017a); further information is provided in the specific PGM factsheets:

- Autocatalysts:** Autocatalysts are by far the most important application of PGM. Platinum, palladium and rhodium are essential for the function of catalytic converters to reduce emissions from gasoline and diesel engines, i.e. hydrocarbons (HC), carbon monoxide (CO), nitrogen oxides (NO<sub>x</sub>), and particulate matter (PM). The activity of PGMs enables the reactions to occur at low-temperature conditions, and their durability allows catalytic converters to perform over the life of the vehicle (IPA, 2015a). Palladium accounts for 69% of the global PGM gross demand in autocatalysts, and platinum and rhodium for 24% and 7%, respectively.

Figure 284 illustrates the development of PGM demand for autocatalysts; figures for platinum and palladium refer to European demand, and figures for rhodium to global demand.



**Figure 284: Development of PGM demand for autocatalysts in Europe (platinum, palladium), and globally (rhodium), 2000–2018 (background data from (Johnson Matthey, 2019a) for 2014–2018, (Johnson Matthey, 2018) for 2013, and (Johnson Matthey, 2014) for 2005–2012).**

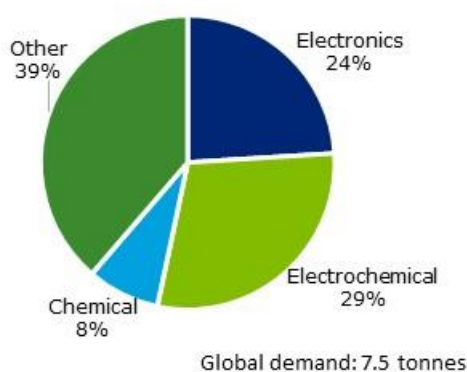
- *Jewellery*: The value and physical properties of PGMs means they are suitable and desirable for high-value jewellery, which accounts for 12% of their consumption (see Figure 283). Platinum is by far the most commonly used PGM in jewellery, followed by palladium (see Figure 283);
- *Catalysts in chemical, electrochemical and petrochemical applications*: PGMs are widely used as catalysts in the industrial sector, primarily in chemical manufacture and petroleum refining. Their properties and high value mean they are particularly suitable for catalytic processes, where only a small quantity of the metal can have a large impact on production and they can generally be recovered at the end of the process. All PGMs are employed as catalysts on an industrial scale (see Figure 283). Platinum is used as a catalyst in a variety of processes, with the most important being petroleum refining (where it is in some applications combined with rhenium) and nitric acid production. Palladium and rhodium are both used in the production of several plastics and polymer precursors. Ruthenium is used in ammonia production, as well as with iridium in electrochemical processes;
- *Electronics*: PGMs have various uses in the electronics industry. Both platinum and palladium are used in the manufacture of some printed circuit boards. The use of palladium in electronics has grown with the miniaturisation of components for applications such as mobile phones where palladium is used in multilayer ceramic capacitors. Platinum and ruthenium find specific uses in computer hard disk drives, and iridium is linked to the manufacturing process for LEDs and organic LEDs;
- *Glass*: PGMs are used in the manufacture of some glass types when high processing temperatures are used. Their high melting point, strength and resistance to corrosion make them suitable for this purpose. Both platinum and rhodium are employed in the production of glass fibre, LCD manufacture and some other types of glass (but not for bottle glass);
- *Medical industry and dental*: PGMs, mainly palladium, find uses in dental applications, specifically in alloys for fillings and bridges. They are also used in components in medical scanners, sensors and drugs;

- *Investments:* Due to their high value, platinum and palladium are also used for investment purposes such as in exchange-traded funds (ETFs). Investment in the other PGMs is relatively small. Investment can be both a source of supply (i.e. recycling or sales) and a component of demand (i.e. purchases).

### 19.5.2.2 Uses and end uses of individual PGMs

#### *Uses and end-uses of iridium*

The predominant applications of iridium are in crucibles for growing single crystals for electronics, and dimensionally stable anodes for the electrochemical production of chlorine and sodium hydroxide. In 2018, electrochemical applications accounted for 29%, electrical applications for 24%, and chemical applications for 8% of the global gross demand (see Figure 285). A range of other minor uses, including spark plugs and medical implants, accounted for almost 40% of the global gross demand. There are no specific data for the applications of iridium in Europe.



**Figure 285: Global end uses of iridium in 2018. Background data from (Johnson Matthey, 2019a)**

The relevant industry sectors and their 2- and 4-digit NACE codes are summarised in Table 110.

**Table 110: Iridium applications, 2-digit and examples of associated 4-digit NACE sectors, and value-added per sector (Eurostat, 2019c)**

Applications	2-digit NACE sectors	Value added of NACE 2 sector (millions €)	4-digit NACE sectors
Electronics	C26 - Manufacture of computer, electronic and optical products	65,703	C2611 - Manufacture of electronic components
Chemical	C20 - Manufacture of chemicals and chemical products	105,514	C2014 - Manufacture of other organic basic chemicals
Electrochemical	C20 - Manufacture of chemicals and chemical products	105,514	C2013 - Manufacture of other inorganic basic chemicals
Other			C2931 - Manufacture of electrical and electronic equipment for motor vehicles

The applications of iridium are described below:

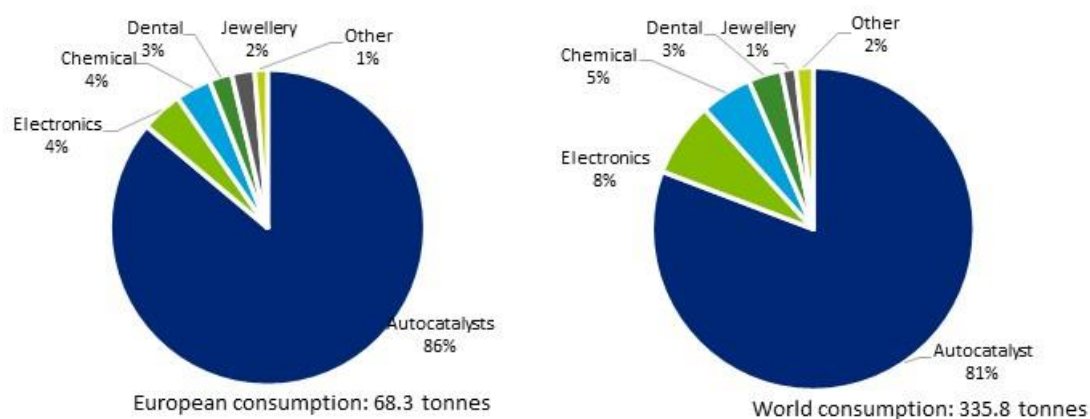
- *Electronics/Electrical.* On account of its high melting point and resistance to chemical attack, iridium is a highly suitable material for high-temperature crucibles utilised to grow synthetic, high-purity single crystals, especially of metal oxides,

which are used by the electronics industry in several applications. Examples are the Yttrium Aluminium Garnet (YAG) crystals for lasers, the LSO and GSO crystals for medical scanners and X-ray scanners for baggage and container screening, sapphire that provides as a substrate for the production of gallium nitride which is used for light-emitting diodes (LEDs) increasingly utilised in flat-screen displays and portable electronic equipment (European Commission, 2017), and lithium tantalate crystals used as the substrate for filters in mobile phones (Johnson Matthey, 2018). Iridium can also be used in the organic light-emitting diodes (OLEDs) technology (Moss et al., 2013);

- *Electrochemical.* Iridium and ruthenium oxides are employed in coatings for anodes in the electrochemical production of chlorine and sodium hydroxide by the chlor-alkali industry. Iridium is also used in coatings of anodes used in electrogalvanising, electrowinning, as well as of electrodes employed in the process of electrolytic chlorination of water and ballast water treatment (together with ruthenium). The relative quantities of ruthenium and iridium used in these applications differ (Johnson Matthey, 2019a);
- *Chemical industry.* Iridium's catalytic properties enable its use in the manufacture of chemicals as iridium catalysts to promote hydrogenation, acetic acid synthesis and hydroformylation for the production of aldehydes. Iridium can also be used in conjunction with platinum in a few niche reforming applications in oil refining;
- *Other.* Iridium is also employed in a range of other applications. In the automotive industry, it is used mainly as a component in exhaust emission control systems of gasoline direct injection (GDI) engines and alloys for high-performance spark plugs. Due to its biological compatibility, oxidation resistance, durability and electrical conductivity, electrodes for medical implants such as heart pacemakers, aura and retinal implants, neuromodulation and neurostimulation devices, are made of platinum-iridium alloys. Moreover, iridium isotopes are the active ingredient in platinum radiotherapy (brachytherapy) implants for cancer treatment. Platinum-iridium alloys are also used in jewellery and for high-temperature equipment required for the manufacture of glass. Due to its unique corrosion resistance and hardness, iridium has been used in platinum alloys to set standards in weights and measures (e.g. the international prototype standard kilogram of mass and the standard metre were made from an alloy containing 90% platinum and 10% iridium). Finally, iridium is used, together with platinum, as a catalyst for hydrogen generation for fuel cells.

#### Uses and end-uses of palladium

The patterns of end uses of palladium are similar in Europe in comparison to the global context.



**Figure 286: End uses of palladium in Europe in 2018 (left), and global end uses of palladium in 2018 (right). Background data from (Johnson Matthey, 2019)**

European palladium demand is strongly dominated by its use in catalytic converters for vehicles. In 2018, autocatalysts represented a share of 86% of the total consumption of about 68 tonnes. The other applications contributed with 4% each for electronics and chemicals, 3% dental and 2% jewellery (Johnson Matthey, 2019). The global demand for palladium in 2018 was approximately 336 tonnes. The predominant global use was in autocatalysts, which accounted for 81% of demand. The remainder was used chiefly in electrical/electronics, chemical, dental and jewellery applications.

The above figures for demand do not include investment, as the demand for palladium investment items has been negative in 2018. The trend of selling palladium investment items in the global market is prevailing since 2013.

The relevant industry sectors and their 2- and 4-digit NACE codes are summarised in Table 111.

**Table 111: Palladium applications, 2-digit and examples of associated 4-digit NACE sectors, and value-added per sector (Eurostat, 2019c)**

<b>Applications</b>	<b>2-digit NACE sectors</b>	<b>Value added of NACE 2 sector (millions €)</b>	<b>4-digit NACE sectors</b>
Autocatalysts	C29 - Manufacture of motor vehicles, trailers and semi-trailers	160,603	C2932 - Manufacture of other parts and accessories for motor vehicles
Electronics	C26 - Manufacture of computer, electronic and optical products	65,703	C2611 - Manufacture of electronic components
Chemical	C20 - Manufacture of chemicals and chemical products	105,514	C2015 - Manufacture of fertilisers and nitrogen compounds
Dental	C32 - Other manufacturing	39,160	C3250 - Manufacture of medical and dental instruments and supplies
Jewellery	C32 - Other manufacturing	39,160	C3212 - Manufacture of jewellery and related articles
Investment	There is no NACE code associated with investment and therefore no related value-added		

The applications of platinum, which are also discussed briefly in the PGM factsheet, are described below:

- *Autocatalysts.* Palladium is used as the dominant active ingredient (in combination with rhodium) in catalytic converters to control polluting exhaust emissions of unburnt hydrocarbons, carbon monoxide and oxides of nitrogen from gasoline-powered vehicles. Nowadays, autocatalysts are capable of eliminating 98% of harmful emissions from engine exhausts, and the risk of capacity loss through poisoning by the sulphur and lead present in the fuels has been considerably reduced. Moreover, palladium's use in diesel-powered vehicles has been growing the last years and manufacturers increase the proportion of palladium to platinum on diesel catalysts, in particular after the availability of fuel with a very low sulphur content (under 10 ppm) and the development of catalysed particulate filters (DPF), in which palladium enables high-temperature regeneration to take place without damaging the catalyst. The quantities and proportions of platinum and palladium used in autocatalysts have varied considerably over time in response to technological changes and price variations. According to (European Commission,

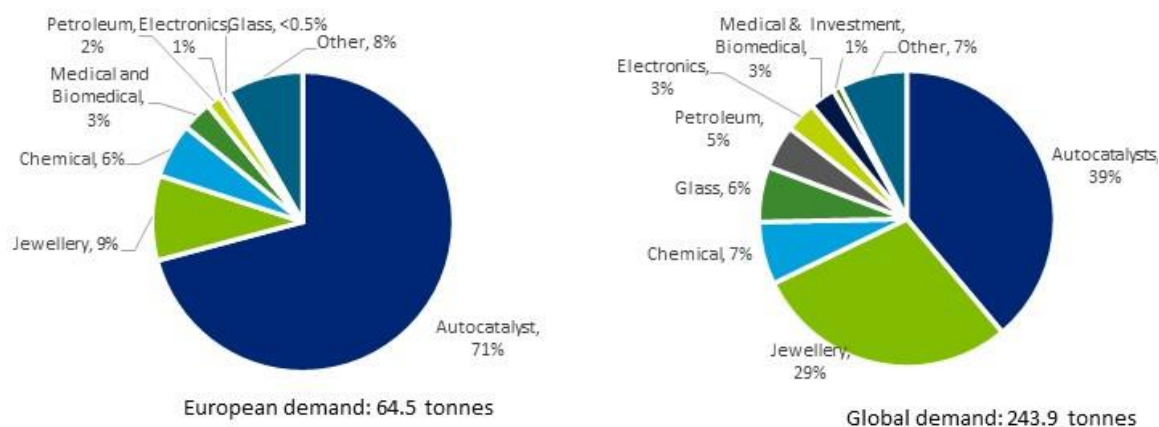
2017), close to 90% of palladium in autocatalysts is used for light-duty gasoline engines, with the remainder used in light-duty diesel;

- *Electrical*. Palladium coatings, electrodeposited or chemically plated, are widely used in electronic components as an effective and long-lasting plating on account of palladium's electrical conductivity and durability. It's most important use is in multi-layer ceramic capacitors (MLCC), especially for demanding applications such as automotive engine management systems, broadcasting equipment, defence and aerospace electronics, medical devices, and consumer electronics requiring high reliability. Smaller amounts of palladium are used in the conductive Ag-Pd tracks of hybrid integrated circuits (HIC), primarily used by the automotive sector. Additional applications in the electronics industry are for plating connectors, as an alternative material to gold, as an alternative to Sn-Pb solder. Pd-containing tiny components exist in virtually every type of electronic device, each component containing only a fraction of a gram of metal;
- *Chemical industry*. Industrial palladium catalysts are very effective in chemical reactions that require hydrogen exchange between two reactants, such as those producing butadiene and cyclohexane, the raw materials for synthetic rubber and nylon. Other applications of palladium-based catalysts include the production of terephthalic acid, hydrogen peroxide and high-purity hydrogen. Also, palladium is used by the petrochemical industry to catalyse the hydrocracking process;
- *Jewellery*. In jewellery, palladium is commonly used either as an alloying addition to platinum and gold (white gold) or as palladium jewellery itself;
- *Dental*. Palladium is an essential component of alloys used for dental restorations such as inlays, bridges and crowns. Palladium provides strength, stiffness and durability to the dental alloy while the other metals of the alloy (i.e. gold, silver, zinc and copper in varying proportions) improve malleability. In low gold alloys used in dentistry, palladium content typically ranges from 50% to 80% by weight. The use of Pd-containing alloys varies widely from country to country depending on customer preferences;
- *Investment*. Palladium, like platinum and rhodium and similar to gold and silver, is also used for investment in the form of physical (e.g. collectable and bullion coins, bars) or financial assets (e.g. exchange-traded funds). Unlike platinum, almost all palladium investment is accounted for by exchange-traded funds (ETFs);
- *Other*. Other applications include palladium catalysts to control pollution from non-road engines and stationary sources, archival and museum suitable photographic prints, palladium-zeolite ethylene scavenger for fruit and vegetable storage, hydrogen storage, and hydrogen purification in the form of Pd-Ag membranes.

### *Uses and end-uses of platinum*

There are some notable differences between patterns of platinum use in Europe and the rest of the world.





**Figure 287: End uses of platinum in Europe in 2018 (left), and global end uses of platinum in 2018 (right). Background data from (Johnson Matthey, 2019b)**

In Europe, the demand of platinum is strongly dominated by autocatalysts, reflecting the dominance of diesel-powered vehicles in the European fleet compared with the rest of the world; in 2018, platinum demand for autocatalysts represented a share of 71% of the total consumption of about 65 tonnes in Europe, and almost half (48%) of the total platinum demand worldwide for autocatalysts (Johnson Matthey, 2019b). The share of autocatalysts in the world demand of platinum is much lower (39%). The second most important use of platinum is in jewellery, which also shows a marked difference between Europe and the rest of the world. Jewellery accounted for about 29% of world platinum demand in 2018, compared with close to 9% in Europe. This difference can be attributed to the growing market for platinum jewellery in China, Japan and India (European Commission, 2017). Chemical manufacture represents the third most important application, with a 6% share of platinum demand in Europe and 7% globally in 2018.

Demand for investment in Europe has been negative in 2013, 2014, 2015, and 2018 as investors returned their platinum holdings to the market. In contrast, the level of global investment demand for platinum fluctuated considerably between 2011 and 2018 but remained positive (Johnson Matthey, 2016; Johnson Matthey, 2019b).

The relevant industry sectors and their 2- and 4-digit NACE codes are summarised in Table 112.

**Table 112: Platinum applications, 2-digit and examples of associated 4-digit NACE sectors, and value-added per sector (Eurostat, 2019c)**

Applications	2-digit NACE sectors	Value added of NACE 2 sector (millions €)	4-digit NACE sectors
Autocatalysts	C29 - Manufacture of motor vehicles, trailers and semi-trailers	160,603	C2932 - manufacture of other parts and accessories for motor vehicles
Jewellery	C32 - Other manufacturing	39,160	C3212 - manufacture of jewellery and related articles
Chemical	C20 - Manufacture of chemicals and chemical products	105,514	C2013 - manufacture of other inorganic basic chemicals; C2014 - manufacture of other organic basic chemicals; C2015 - manufacture of

<b>Applications</b>	<b>2-digit NACE sectors</b>	<b>Value added of NACE 2 sector (millions €)</b>	<b>4-digit NACE sectors</b>
			fertilisers and nitrogen compounds
Medical	C32 - Other manufacturing	39,160	C3250 - manufacture of medical and dental instruments and supplies
Petroleum	C19 - Manufacture of coke and refined petroleum products	17,289	C1920 - manufacture of refined petroleum products
Electronics	C26 - Manufacture of computer, electronic and optical products	65,703	C2620 - manufacture of computers and peripheral equipment; C2640 - manufacture of consumer electronics; C2680 - manufacture of magnetic and optical media
Glass manufacture	C23 - Manufacture of other non-metallic mineral products	57,255	C2311 - manufacture of flat glass
Investment	There is no NACE code associated with investment and therefore, no related value-added.		

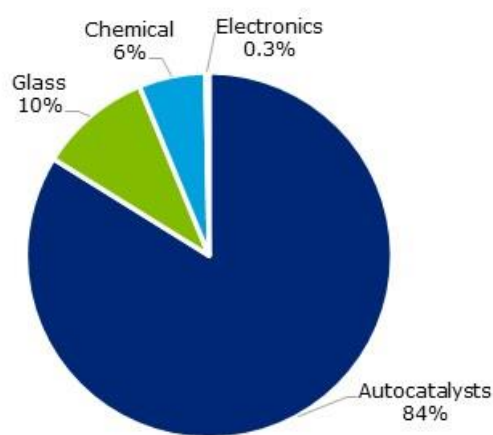
Platinum's unique physical and chemical properties have been exploited for a wide range of applications. The applications of platinum, which are also discussed briefly in section 19.5.2.1, are the following (Johnson Matthey, 2019a, IPA, 2012, Gunn, 2014, BRGM, 2014):

- *Autocatalysts.* Platinum is the principal active component in catalytic converters and filters fitted to diesel-powered vehicles to reduce harmful exhaust emissions. Emissions of hydrocarbons (HC), carbon monoxide (CO) and particulate matter (PM) are eliminated by over 98%. Platinum-rich autocatalysts oxidise any unburnt HC and CO to water and carbon dioxide. Their use became universal in diesel engines due to the more oxidising environment of a diesel exhaust stream and the lower operating temperatures in comparison with gasoline engines, as well as because of the higher sulphur tolerance of platinum. Also, various systems employing platinum or platinum-palladium filters have been developed for diesel vehicles to trap soot particles from exhaust emissions and oxidise the soot to carbon dioxide;
- *Jewellery.* Platinum alloys (e.g. Pt 96% - Cu 4%, Pt 95% - Pd 5%) are widely used to make fine jewellery. Today, platinum is a trendy metal for bridal or fashion jewellery;
- *Chemical industry.* Many chemical processes employ platinum-based catalysts for the production of bulk and speciality chemicals. A significant application is the use of a platinum catalyst in the conversion of ammonia to nitric oxide, which is the first step in the process of nitric acid production. Among nitric acid's downstream uses is the production of nitrogen fertilisers, explosive-grade ammonium nitrate, adipic acid for making nylon, toluene diisocyanate for manufacturing polyurethane etc. Another important application of platinum catalysts is in the manufacture of specific silicones. Platinum is also employed in the production of paraxylene (PX) which is an intermediate in the production of PET used for plastics and polyester textiles. Lastly, platinum is used in the pharmaceutical industry as a selective hydrogenation agent;

- *Medical and dental.* The use of platinum in the medical sector comprises pharmaceuticals and biomedical components. In particular, platinum is an active ingredient in anti-cancer drugs as certain compounds (i.e. cisplatin, carboplatin and oxaliplatin) are effective in the treatment of a range of cancers by inhibiting cell division. In addition, on account of its excellent biocompatibility, outstanding resistance to oxidation, durability and electrical conductivity combined with its radio-opacity, platinum is an ideal material for electrodes in temporary or permanent biomedical implants such as heart pacemakers and defibrillators, aural and retinal implants, neuromodulation devices, brachytherapy implants, catheters for arteries and coronary stents (with chromium). Lastly, platinum is used in dental restorative alloys usually mixed with gold or silver in varying ratios (e.g. high gold alloys with around 10% of platinum by weight), although to a lesser extent than palladium;
- *Petroleum industry.* Platinum-based catalysts are indispensable for crude oil refining. In particular, they are used in the catalytic reforming process in oil refineries to reform naphtha into high octane blending components for gasoline (i.e., reformates). The substrate of the catalyst (e.g. alumina) is coated with Pt solutions, and the platinum content of the catalyst usually is less than 0.6% by weight;
- *Electrical/electronics.* In the electronics industry, platinum is a critical component of the magnetic coating on hard disks that increase their data storage capacity. It is also used in high-temperature thermocouples, in fuel cells as a catalyst, and multilayer ceramic capacitors (MLCC), even though to a lesser extent than palladium;
- *Glass industry.* Special containers and other equipment (e.g. pipes, linings, nozzles, drawing dies) fabricated from platinum and platinum-rhodium alloys are employed in glass manufacturing to handle molten glass, i.e. to line vessels that contain, channel and form molten glass. On account of platinum's high melting point and resistance to corrosion by molten glass, such equipment can withstand the harsh conditions in glassmaking while maintaining the purity of the glass. Platinum-based equipment is employed in the manufacture of speciality glass such as reinforcement fibreglass, glass for liquid crystal display (LCD) and plasma screens, ceramic glass, optical & ophthalmic glass and container glass;
- *Investment.* Due to its physical property of being practically unreactive and its scarcity in the earth's crust, and similar to gold and silver, platinum is acceptable as an investment asset and means of exchange. Several different investment products have been introduced to meet demand, including either physical assets (e.g. bars, coins) or financial assets (e.g. exchange-traded funds). Financial assets make investments simpler as they allow investors to own platinum, without the difficulties associated with holding the metal physically;
- *Other.* A range of other platinum applications include electrode tips of automotive and aviation spark plugs, oxygen sensors in car exhaust systems for efficient fuel management, ignition wires in airbag inflation devices, platinum-aluminide coatings on turbine blades to provide protection against corrosion and high-temperatures, platinum-clad anodes for cathodic protection of sea vessels, use of platinum catalysts in emission control from stationary sources (e.g. combustion plants), electrodes in carbon monoxide sensors, archival and museum suitable photographic prints, standards in weights and measures etc.

#### *Uses and end-uses of rhodium*

Autocatalysts is the predominant application of rhodium, accounting for over 80% of total gross demand in 2018. Other areas in which rhodium is essential are the manufacture of glass and the chemicals sector.



Global demand: 32.2 tonnes

**Figure 288: Global end uses of rhodium in 2018. Background data from (Johnson Matthey, 2019a)**

The relevant industry sectors and their 2- and 4-digit NACE codes are summarised in Table 113.

**Table 113: Rhodium applications, 2-digit and examples of associated 4-digit NACE sectors, and value-added per sector (Eurostat, 2019c)**

Applications	2-digit NACE sectors	Value added of NACE 2 sector (millions €)	4-digit NACE sectors
Autocatalysts	C29 - Manufacture of motor vehicles, trailers and semi-trailers	160,603	C2932 - Manufacture of other parts and accessories for motor vehicles
Glass	C23 - Manufacture of other non-metallic mineral products	57,255	C2311 - Manufacture of flat glass
Chemical	C20 - Manufacture of chemicals and chemical products	105,514	C2015 - Manufacture of fertilisers and nitrogen compounds
Electronics	C27 - Manufacture of electrical equipment	80,745	C2712 - Manufacture of electricity distribution and control apparatus

The applications of rhodium are described below:

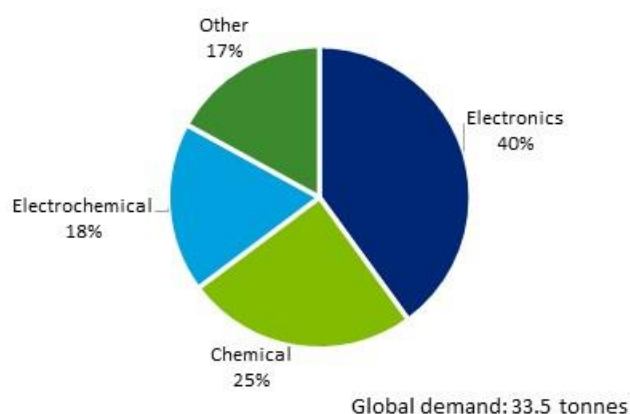
- *Autocatalysts*. Global demand for rhodium is dominated by catalytic converters to remove harmful emissions from vehicle exhaust gases. Its catalytic qualities (outstanding activity and selectivity) and strength are essential for improving the converters' effectiveness. Rhodium is employed along with palladium in three-way catalysts for gasoline engines to catalyse the reduction of nitrogen oxides (NO<sub>x</sub>) to nitrogen, and which account for more than 95% of total autocatalyst usage of rhodium (Johnson Matthey, 2015). Rhodium is indispensable for the function of gasoline catalytic converters due to its ability to maintain a high conversion of NO<sub>x</sub> in the exhaust gases;
- *Glass*. On account of rhodium's high melting point, hardness, temperature stability and corrosion resistance, alloying platinum with rhodium in various proportions (from 5% up to 30% rhodium) increases strength and extends the life of platinum-

based tooling used by the glass manufacture sector in a broad range of glass products (e.g. fibreglass, LCD glass);

- *Chemical industry.* Rhodium is used in conjunction with other metals in long established formulations to catalyse specific chemical processes for the manufacture of various organic and inorganic chemicals. Platinum-rhodium alloys in the form of gauze catalysts are used in the catalytic oxidation of ammonia to produce nitric oxide, which is the input material for the production of nitric acid. Many complex rhodium compounds have also been developed for use as catalysts in the production of various organic chemicals such as aldehydes, acetic acid production and hydrogenation reactions;
- *Other.* Electrodeposition of rhodium gives hard and reflective surfaces used in the manufacture of mirrors for optical instruments. A range of other minor uses includes investment (e.g. bars and ETFs), plating of jewellery (e.g. white gold) for an improved finish, mammography x-ray machines, Pt-Rh alloys for high-temperature thermocouples, spark plug tips.

#### *Uses and end-uses of ruthenium*

The predominant application of ruthenium is in electronic components and products, such as hard disk drives and contacts for thermostats and relays, which accounted for 40% of global gross demand in 2018 (Figure 289). The remainder was used in chemical process catalysts (25%) and electrochemical applications (18%). A range of other minor uses, accounted for 17% of the total, including spark plugs, jewellery, dentistry and superalloys. There are no specific data for the uses of ruthenium in Europe. The relevant industry sectors and their 2- and 4-digit NACE codes are summarised in Figure 289.



**Figure 289: Global end uses of ruthenium in 2018. Background data from (Johnson Matthey, 2019a)**

**Table 114: Ruthenium applications, 2-digit and examples of associated 4-digit NACE sectors, and value-added per sector (Eurostat, 2019c)**

Applications	2-digit sectors	NACE	Value added of NACE 2 sector (millions€)	4-digit NACE sectors
Electronics	C26 - Manufacture of computer, electronic and optical products		65,703	C2620 - Manufacture of computers and peripheral equipment
Chemical	C20 - Manufacture of chemicals and chemical products		105,514	C2014 - Manufacture of other organic basic chemicals

			C2013 - Manufacture of other inorganic basic chemicals
Electrochemical	C20 - Manufacture of chemicals and chemical products	105,514	C2013 - Manufacture of other inorganic basic chemicals

The applications of ruthenium are described below:

- *Chemical.* Ruthenium catalysts are employed in the production of a variety of speciality chemicals, as well as in the production of bulk inorganic and organic chemical commodities, i.e. the Cativa acetic acid process, the Kellogg Advanced Ammonia Process (KAAP), and the manufacture of caprolactam and adipic acid as feedstocks for synthetic polymer production (process applied in China) (Johnson Matthey, 2019a).
- *Electrical* A platinum-ruthenium alloy plays an important role in the complex structure of layered materials in hard disk drives which apply the perpendicular magnetic recording (PMR) technology to increase the data storage capacity per unit area. Ruthenium is also alloyed to palladium alloys to increase resistance to abrasion in electrical contact surfaces for thermostats and relays. It is also used in resistors in electronic circuits;
- *Electrochemical.* Ruthenium oxides and ruthenium-iridium oxides are used as coatings of the titanium anodes employed by the chlor-alkali process for the electrochemical production of chlorine and sodium hydroxide. Smaller electrochemical uses, in combination with iridium, include the coatings of electrodes employed by devices for the electrolytic chlorination of swimming pools and ballast water treatment on ships, as well as in electrowinning in base metal refineries. The relative quantities of ruthenium and iridium used in these applications vary (Johnson Matthey, 2019a);
- *Other.* Small amounts of ruthenium are sometimes added to platinum and palladium alloys used in jewellery and dentistry to impart hardness. In the Fischer-Tropsch process for bioenergy generation, ruthenium is used in a cobalt-based catalyst at low levels (Moss *et al.*, 2011). Other small uses are found in platinum-ruthenium electrodes for fuel cells and fountain pen nibs.

## 19.6 Substitution

---

### 19.6.1 Substitution of platinum group metals in general

(Nassar, 2015) presented a detailed review of the potential for PGM substitution in the major commercial applications of the PGMs. He concluded that in most applications, substitution is either not possible or impractical for various technical or economic reasons. Where substitutes are available, these are most commonly other PGMs or nickel, cobalt and gold. Moreover, the fact that the PGMs are co-products produced together from the same ores means that the supply of the various PGMs is coupled and thus their ability to substitute for one another in the event of supply disruption is limited. Overall it was concluded that the potential for PGM substitution in most high-volume applications is limited.

In general, the best and commonly the only available substitute is of one PGM for another. Substitution among PGM may occur when the price differential is large enough, as it had happened in the 2000 to 2001 period when the high palladium price stimulated substitution by platinum. For the same reason, nickel and copper were also substituted for palladium in certain electronics applications, albeit with some reduction in performance (Gunn, 2014). Gold is another possible substitute for PGMs, but its price has deterred its widespread use for this purpose (European Commission, 2017a).

At present, there are virtually no effective and economical alternatives to PGMs in autocatalysts. Some substitution is possible for diesel engines where a certain amount of platinum may be substituted by palladium. In addition, the PGMs perform important roles as catalysts in the manufacture of various chemicals, both organic and inorganic, and in petroleum refining. In many cases, the catalyst is a mixture of more than one PGM and other metals, which has been optimised over a long period. Consequently, there is a little practical incentive to substitute the PGM unless the prevailing economic conditions make it important to do so. Furthermore, substituting PGMs in closed-loop applications offers little economic benefit as life cycle losses in these applications are very small (European Commission, 2017a).

Substitution or the thrifting of the PGMs, i.e. using less material in an application with little or no reduction in performance, has long been an objective because of the prevailing high prices and the general designation of PGMs as 'critical' in many parts of the world. For example, autocatalysts have become more efficient, and smaller quantities of PGMs are required to achieve the same performance. However, the amounts used have remained nearly constant as emission standards have become increasingly stringent (Gunn, 2014). Considerable research is in progress which aims to either reduce or replace the use of PGMs in various applications (European Commission, 2017a). For example, the EC-funded Partial-PGM project is aiming to achieve a reduction of more than 35% of PGMs used in a hybrid three-way catalytic converters (TWC)/Gasoline Particulate Filter (GPF) for gasoline vehicles, either by increasing performance or by replacement with transition metals (Partial-PGMs, 2019). Another EC-funded project, CritCat, aims to develop substitutes based on ultra-small transition metal nanoparticles for PGM-based catalysts used in chemical processes and emerging energy-conversion technologies (CritCat, 2019).

Potential substitutes for applications of the individual PGMs are reviewed in the five specific PGM factsheets.

## 19.6.2 Substitution of individual platinum group metals

### 19.6.2.1 Substitution of iridium

(Nassar, 2015) reviewed the possibilities for elemental substitution of the PGM in their main applications. Given that the PGM are co-products, in the event of a supply disruption of iridium, the ability to substitute it with other PGM is likely to be limited. Similarly, given that iridium production is highly concentrated in southern Africa, it would not be easy to bring new supply on stream quickly because the level of production is dependent on that of the 'paying' metals, platinum and palladium (European Commission, 2017).

In the electrical industry where iridium is used in crucibles for the growth of high-purity single crystals of metal oxides, possible substitutes include molybdenum and tungsten (Nassar, 2015). However, the performance of molybdenum crucibles that can be used to grow sapphire and yttrium aluminium garnet crystals is considered poor (Graedel *et al.*, 2015b). Data on the market share of these alternative materials are not available.

In the chlor-alkali industry, the membrane technology, which is gradually replacing alternative methods of chlorine manufacture, uses anodes based on a mixture of iridium and ruthenium. No information exists on the relative proportions of each PGM used for neither this purpose nor the degree to which one can be substituted by the other. Many other anode compositions have been patented, but few are in commercial use (Nassar, 2015). For example, ruthenium and ruthenium-tin oxide coatings are an alternative to the ruthenium-iridium coatings in the anodes used by the chlor-alkali industry (Graedel *et al.*, 2015b). For other chemical applications in which iridium is used as a process catalyst, it is reported that a rhodium catalyst is used in the Monsanto acetic acid synthesis process (Graedel *et al.*, 2015b).

Finally, in certain applications in which iridium is used as an alloying agent with platinum, elements other than iridium may be used in the platinum alloy (Graedel *et al.*, 2015b).

On a scale of 0 to 100<sup>197</sup>, iridium's substitution index has been assessed as 69 by (Graedel *et al.*, 2015a).

### 19.6.2.2 Substitution of palladium

The high price of palladium and the perceived possibility of future supply disruptions have led to considerable interest in finding alternatives to palladium in many applications. (Nassar, 2015) reviewed the possibilities for elemental substitution of the PGM in their main uses. For palladium, the potential substitutes are other PGM, gold or base metals, although these may have associated price or performance penalties.

Given that the PGM are co-products, in the event of a supply disruption of palladium, the ability to substitute it with platinum is likely to be limited. For particular applications of palladium, the following potential substitutes are identified (Graedel *et al.*, 2015a):

- In autocatalysts, platinum and palladium can only substitute for each other being equally effective at controlling emissions from gasoline-powered vehicles (Graedel *et al.*, 2015a; Tercero *et al.*, 2018). Palladium has been substituted for platinum in most gasoline-engine catalytic converters because of the historically lower price for palladium relative to that of platinum (USGS, 2019). About 25% of palladium can routinely be substituted for platinum in diesel catalytic converters; the proportion can be as much as 50% in some applications (USGS, 2019);
- In electronics, nickel-based multilayer ceramic capacitors can be used in place of those based on palladium with good performance (Graedel *et al.*, 2015a).

---

<sup>197</sup> On this scale, zero indicates that exemplary substitutes exist for all major uses and 100 indicates that no substitute with even adequate performance exists for any of the major uses.



- Platinum jewellery alloyed with elements other than palladium is considered a substitute with good performance Substitute refers to platinum jewellery alloyed with elements other than palladium with good performance(Graedel *et al.*, 2015a);
- In dental restorations, alloys with palladium as an alloying agent can be replaced by nickel-based metal alloys (Graedel *et al.*, 2015a);
- In process catalysts for chemical and petroleum applications, nickel catalysts might be used in the hydrogenation of alkynes to alkenes, indirect synthesis of hydrogen peroxide, and in hydro-cracking and hydro-treating. Performance is assessed as adequate (Graedel *et al.*, 2015a);
- Palladium used in coins and exchange-traded funds may be substituted by gold, silver, and platinum as an alternative medium for investing (Graedel *et al.*, 2015a). The level of substitution depends on many factors, chiefly to price because, unlike other applications, palladium investment is strongly price-elastic (European Commission, 2017);
- In other applications, such as in control of industrial emissions and oxygen sensors, other PGM can be used instead of palladium(Graedel *et al.*, 2015a).

On a scale of 0 to 100<sup>198</sup>, palladium's substitution index has been assessed as 39 by (Graedel *et al.*, 2015b).

### 19.6.2.3 Substitution of platinum

The high price of platinum and the perceived possibility of future supply disruptions have led to considerable interest in research for substitute materials (European Commission, 2017; Nassar, 2015) reviewed the options for elemental substitution of the PGM in their main applications. For platinum, the potential substitutes are other PGM or base metals, although these may have associated price or performance penalties. Given that the PGM are co-products, in the event of a supply disruption of platinum, the ability to substitute it with palladium is likely to be limited. For particular applications of platinum, the following potential substitutes are listed below:

- In autocatalysts, the only viable substitution option is replacement of platinum with palladium (and vice versa) (Tercero *et al.*, 2015). In most gasoline-engine catalytic converters, palladium has been substituted for platinum because of the historically lower price for palladium relative to that of platinum. In diesel catalytic converters, palladium can replace for up to 25% of platinum (the proportion can be as much as 50% in some applications), but not completely (USGS, 2019; Graedel *et al.*, 2015a). This may occur when the price differential between the metals is large enough (European Commission, 2017);
- Although the substitution of platinum in jewellery is possible, in practice, cultural attitudes and historical factors are restricting factors (European Commission, 2017). Palladium can substitute platinum as a jewellery metal and alloying agent in white gold (Graedel *et al.*, 2015a);
- In the investment sector platinum used in bars, coins, and exchange-traded funds may be substituted by gold, silver, and platinum as an alternative medium for investing (Graedel *et al.*, 2015b). The level of substitution depends on many factors, chiefly to price because, unlike other applications, platinum investment is strongly price-elastic (European Commission, 2017);
- In process catalysts for the production of chemicals, cobalt oxide can substitute platinum in the production of nitric acid with adequate performance. In petroleum refining processes, molybdenum oxide-based catalysts that were used in the older reforming process are potential substitutes but with poor performance (Graedel *et al.*, 2015b);

---

<sup>198</sup> On this scale, zero indicates that exemplary substitutes exist for all major uses and 100 indicates that no substitute with even adequate performance exists for any of the major uses.

- For glass manufacturing equipment, iridium is a possible substitute but with reduced performance (Graedel *et al.*, 2015b);
- Palladium-based alloys as alternatives to platinum-based alloys in dental and biomedical applications with adequate performance (Graedel *et al.*, 2015b);
- In electrical applications, iron-palladium and cobalt-palladium alloys in thin films have been investigated for use in computer hard disk drives (Graedel *et al.*, 2015b);
- In other applications, including stationary pollution control, spark plugs and oxygen sensors, and corrosion-resistant coatings, other PGM can presumably be used in some of these Other platinum-group metals can likely be used in some of these other applications (Graedel *et al.*, 2015b).

On a scale of 0 to 100<sup>199</sup>, platinum's substitution index has been assessed as 66 by (Graedel *et al.*, 2015a).

#### 19.6.2.4 Substitution of rhodium

The high price of rhodium, its price volatility and the perceived possibility of future supply disruptions have led to considerable interest in finding alternatives in many applications.

(Nassar, 2015) reviewed the possibilities for elemental substitution of the PGM in their main applications. For rhodium, the potential substitutes are other PGM, gold or base metals, although these may have associated price or performance penalties. Given that the PGMs are co-products, in the event of a supply disruption of rhodium, the ability to substitute it with other PGMs is likely to be limited. According to (Graedel *et al.*, 2015b):

- There are no effective substitutes for rhodium in *autocatalysts* for the control of NO<sub>x</sub> emissions. According to (European Commission, 2017), although rhodium substitution might be possible, there is generally little economic or technical incentive to do so, especially as the catalysts are recycled very efficiently;
- In *chemical applications*, cobalt is a potential substitute for process catalysts used in the conversion of alkenes to aldehydes. Ruthenium is a competing material in catalysts for acetic acid production (Cativa process) (Johnson Matthey, 2019a);
- For *glass manufacturing equipment* where rhodium is used as an alloying agent with platinum, the use of platinum either alone or with an alloying agent other than rhodium, such as gold or iridium, is a potential substitute;
- For *electrical applications*, in which rhodium is used as an alloying agent with platinum in thermocouples, nickel is a possible substitute in type K and type N thermocouples that can be used in oxidising or inert atmospheres up to 1,260 °C;
- In *other applications*, including electroplating onto metal surfaces, such as jewellery, to provide protection and finishing, rhodium coatings are noted as being superior to all other platinum-group metal coatings in terms of hardness, mechanical and chemical stability, and reflectivity.

On a scale of 0 to 100<sup>200</sup>, rhodium's substitution index has been assessed as 96 by (Graedel *et al.*, 2015a).

#### 19.6.2.5 Substitution of ruthenium

(Nassar, 2015) reviewed the possibilities for elemental substitution of the PGM in their main applications. Given that the PGM are co-products, in the event of a supply disruption of ruthenium, the ability to substitute it with other PGM is likely to be limited. Similarly, given that ruthenium production is highly concentrated in South Africa, it would not be

---

<sup>199</sup> On this scale, zero indicates that exemplary substitutes exist for all major uses and 100 indicates that no substitute with even adequate performance exists for any of the major uses.

<sup>200</sup> On this scale, zero indicates that exemplary substitutes exist for all major uses and 100 indicates that no substitute with even adequate performance exists for any of the major uses.

easy to bring new supply on stream quickly because the level of production is dependent on that of the 'paying' metals, platinum and palladium (European Commission, 2017).

Ruthenium has uses in many electrical components and products. In some of these, substitution by other PGM (iridium, rhodium and palladium) and by silver are possible, but there are no data on market share. An example is oxides of iridium that can substitute for oxides of ruthenium in thick film resistors pastes (Graedel *et al.*, 2015b). Nevertheless, substitution with iridium and rhodium is very unlikely because of their much higher price, and their lower production levels but palladium's availability is several times higher, which means that it might be used as a substitute, despite its higher price (CRM experts, 2019).

Likewise, some substitutes exist where ruthenium is used as a process catalyst in chemical manufacture, but there is no information on the relative proportions of each and the degree to which one can be substituted by the other (European Commission, 2017). For example, in the majority of ammonia synthesis plants, a magnetite-based catalyst is used (Graedel *et al.*, 2015b). This is longer-established synthesis route which competes with the Kellogg Advanced Ammonia Process (KAAP) which utilises ruthenium (Johnson Matthey, 2019a). However, the ammonia synthesis process that uses a ruthenium catalyst is thought to be 20 times more effective than the process that uses the magnetite catalyst (Nassar, 2015). In the chlor-alkali industry iridium-based coatings of dimensionally stable anodes are an alternative to ruthenium-coated anodes (Graedel *et al.*, 2015b); yet, iridium is much more expensive and less available than ruthenium which makes substitution very unlikely (CRM experts, 2019). Finally, other precious metals can presumably be used in most of the other applications in which ruthenium is used as an alloying element (Graedel *et al.*, 2015b).

On a scale of 0 to 100<sup>201</sup>, ruthenium's substitution index has been assessed as 63 by (Graedel *et al.*, 2015a).

---

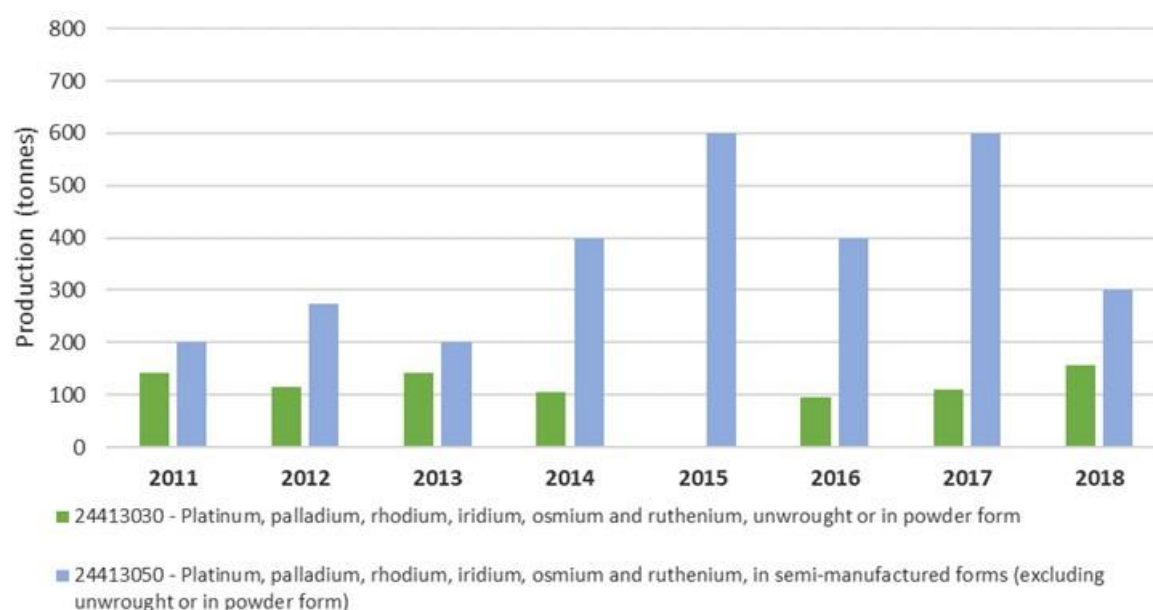
<sup>201</sup> On this scale, zero indicates that exemplary substitutes exist for all major uses and 100 indicates that no substitute with even adequate performance exists for any of the major uses.

## 19.7 Supply

### 19.7.1 EU supply chain

#### 19.7.1.1 EU supply chain of PGMs in general

Refineries in the EU process a wide range of PGM-bearing materials originating from European and overseas sources. These include end-of-life products (e.g. autocatalysts jewellery, WEEE) and manufacturing waste (new scrap). By-products from the non-ferrous mining, processing and manufacturing industries also contribute to the EU supply. These include concentrates, slags, mattes, flue dust, ash, slimes and other residues (European Commission, 2017a). Figure 290 presents the total PGM production in the EU for both primary and secondary sources.



**Figure 290: Production sold of PGM in various forms in EU. Data<sup>202</sup> from Eurostat Prodcom (Eurostat, 2019b)**

PGMs are supplied to the EU market in many different forms. They are generally traded as unwrought metal, in fine powders, in semi-manufactured forms, and as base metals containing PGMs. They are also supplied in various components and final products (e.g. catalysts, jewellery) (European Commission, 2017b). Most of the PGM imports from primary sources are concentrated materials after a first refining stage. The second refining step commonly takes place in Europe (e.g. Belgium, Germany, Norway and the United Kingdom), undertaken by several companies specialised in the refining process (BIO Intelligence Service, 2015; European Commission, 2014).

In the case of catalytic converters, the PGM precursor salts are used to finely disperse the PGMs on an aluminium oxide honeycomb, which is then used within the catalytic converter. Manufacturing of these does occur within the EU by specialist manufacturers, as does placing into vehicles by assemblers. In other applications, the salts or the purified metal may be used depending on particular requirements. For example, metal is supplied to the jewellery and electronics industry, with the consequent stages occurring within the EU linked to the manufacturing base in these applications. Production of metal also occurs

<sup>202</sup> Values presented for PRC 24413030 in 2016 and 2017 are estimates (adjusted on the basis of the production value). The reported production for PRC 24413030 in 2015 is not presented due to low robustness. Data reported for PRC 24413050 are rounded values due to confidentiality (except of the value in year 2012).

within the EU, as a follow on stage from salt production. This involves heat treatment of the metal salts to produce pure PGMs. Alloying between PGMs may take place at this stage. Supply to the chemicals sector is often in the salts form, where other chemicals and catalysts are derived from these precursor materials. Overall, these supply chains are similar to that seen above for the automotive sector, with EU activity across all stages after the initial mining and processing (European Commission, 2014).

#### *EU sourcing of PGMs from primary sources*

A very small amount of mine production of PGMs takes place in the EU. The Kevitsa mine in northern Finland operated by Boliden produces PGM (platinum and palladium) as a by-product of nickel and coppermining. The annual average head grade of the ore ranges from 0.29 parts per million (ppm) to 0.36 ppm for platinum, and between 0.19 ppm and 0.22 ppm for palladium. In 2018, the metal production was 1,576 kilogram of platinum and 1,157 kilogram of palladium in polymetallic concentrates containing nickel, copper, gold, platinum, palladium, and cobalt (Boliden, 2019a). Boliden's smelters, the Harjavalta copper-nickel smelter in Finland and the Rönnskär copper-lead smelter in Sweden, produce annually a PGM concentrate of 2 to 3 tonnes each as an intermediate for further refining. At the Rönnskär smelter, precious metals are also recovered from electronic scrap, which is used in the process to a great extent (Boliden, 2019a).

KGHM in Poland produces minor quantities of platinum and palladium from residual copper slimes generated by the electrolytic refining of ores extracted at the Lubin mines (Lauri *et al.*, 2018; KGHM, 2019); metal is recovered at the Glogow refinery (S&P Global, 2018). The annual production is typically less than 100 kilogram of platinum+palladium (WMD 2019).

Lastly, PGM might be recovered from nickel-copper concentrates produced in the Aguablanca mine in Spain; however, no PGM recovery is taking place (Lauri *et al.*, 2018).

Heraeus in Germany refines metal for the minor PGMs under an agreement with Northam Platinum from South Africa (IPA Industrial expert, 2019).

It is not possible to determine from publicly available data the import flows and the sourcing countries of PGM-containing materials originating from primary sources, e.g. concentrated intermediates for further refining, base metals mattes, etc.

#### *EU sourcing of PGMs from secondary sources*

Europe has a strong position in recycling and refining of PGM with major industrial actors. The principal industries in Europe, refining all forms of PGM-containing waste stream from manufacturing residues to end-of-life products, are Umicore and Johnson Matthey. Other companies in the PGM refining sector operating in Europe include, but are not limited to, BASF, Heraeus, Safina and Vale Europe (Sundqvist Ökvist *et al.*, 2018).

Umicore's Hoboken plant in Antwerp, Belgium, currently recovers base, precious and special metals, and provides related supplies. The production capacity for platinum and palladium is 25 tonnes per annum in each case, and for rhodium 5 tonnes per annum, in the form of high purity powder (minimum 99.95%), known as "sponge". Iridium and ruthenium are also available as a powder/sponge, with a purity of 99.9% (Umicore, 2019a). Umicore's precious metal recovery currently focuses chiefly on recyclable materials and industrial by-products such as electronic scrap, spent automotive and industrial catalysts refining of complex, incineration bottom ashes and other precious metals containing materials, rather than metal concentrates (Umicore, 2019b; European Commission, 2017a).

### 19.7.1.2 EU supply chain of individual PGMs

#### EU supply chain of iridium

The overall EU supply chain of PGM is described in the general PGM factsheet.

The supply chain for iridium is complex and challenging to quantify. Iridium supplies are derived from both primary and secondary sources. Refineries in the EU process a wide range of iridium-bearing materials emanating from European and overseas sources. These include end-of-life products and manufacturing waste (new scrap). By-products and residues from the non-ferrous mining, processing and manufacturing industries also contribute to supply.

There is no production of iridium from mines in the EU. Therefore, the EU is 100% reliant on imports for iridium originating from primary sources (European Commission, 2017). However, as the EU is a significant producer of refined iridium from primary and, mainly, from secondary materials collected domestically or imported, the actual import dependency is lower.

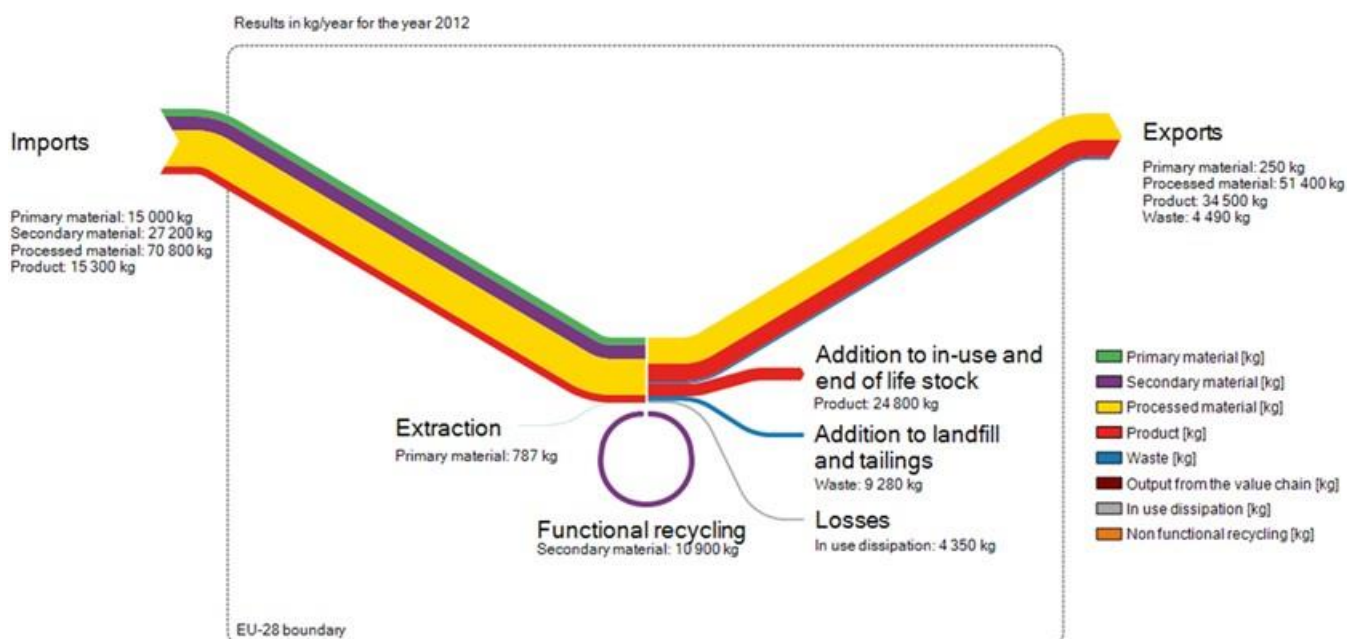
#### EU supply chain of palladium

The overall EU supply chain of PGM is described in the general PGM factsheet.

The supply chain for palladium is complex and challenging to quantify. Palladium supplies are derived from both primary and secondary sources. Refineries in the EU process a wide range of palladium-bearing materials coming from European and overseas sources. These include end-of-life products and manufacturing waste (new scrap). By-products and residues from the non-ferrous mining, processing and manufacturing industries also contribute to supply.

EU mine production makes a small contribution (ca. 0.8 tonnes, average 2012–2016) to EU palladium supply. About 97% is produced in Finland and the remainder in Poland. The net import reliance as a percentage of apparent consumption for palladium in unwrought or in powder form is estimated at 98%.

The palladium flows through the EU economy are illustrated in Figure 291.



**Figure 291: Simplified MSA of palladium flows in the EU for 2012. (BIO Intelligence Service, 2015a)**

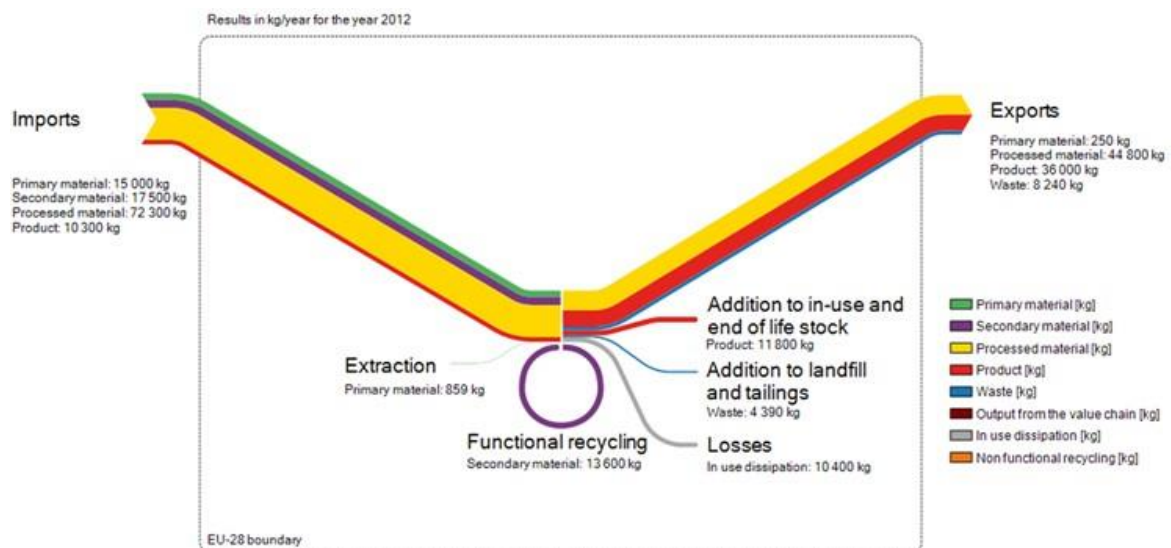
### EU supply chain of platinum

The overall EU supply chain of PGM is described in the general PGM factsheet.

The supply chain for platinum in the EU is complex and challenging to quantify. Platinum supplies are derived from both primary and secondary sources. Refineries in the EU process a wide range of platinum-bearing materials emanating from European and overseas sources. These include end-of-life products and manufacturing waste (new scrap). By-products and residues from the non-ferrous mining, processing and manufacturing industries also contribute to supply.

EU mine production makes a small contribution (ca. 1.0 tonne, average 2012–2016) to EU platinum supply. About 95% is produced in Finland and the remainder in Poland. The net import reliance as a percentage of apparent consumption for platinum in unwrought or in powder form is estimated at 94%.

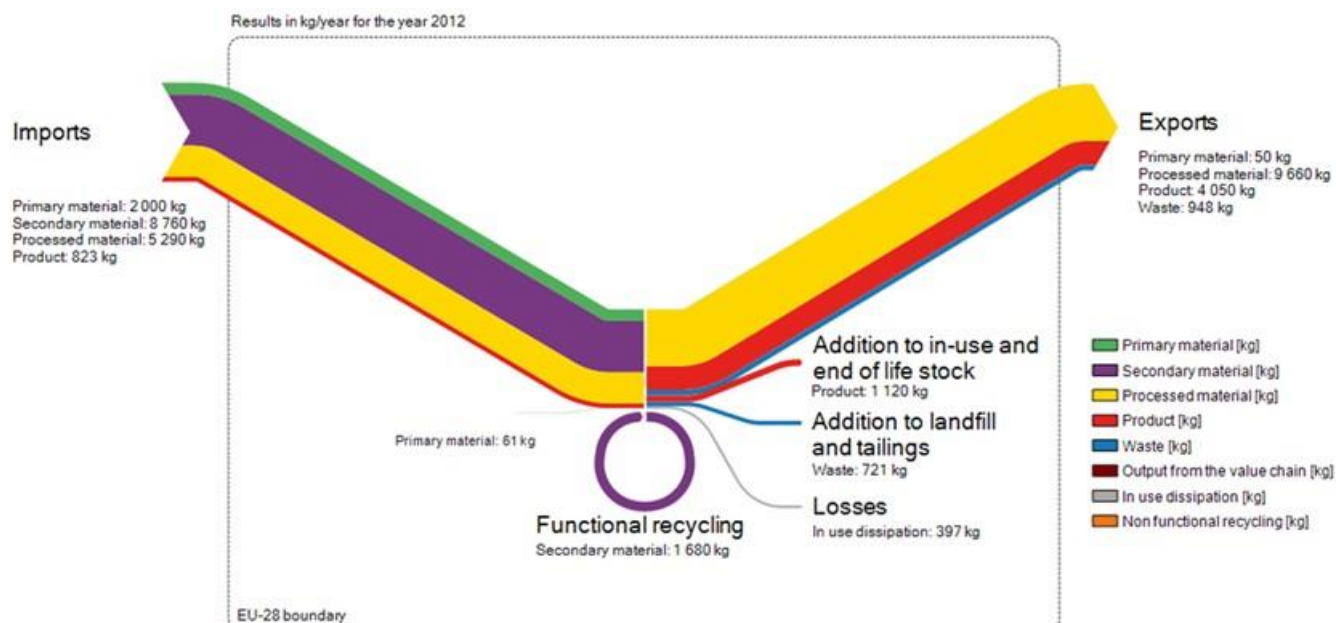
The platinum flows through the EU economy are illustrated in Figure 292.



**Figure 292: Simplified MSA of platinum flows in the EU for 2012. (BIO Intelligence Service, 2015a)**

### EU supply chain of rhodium

Figure 293 shows the rhodium flows through the EU economy.



**Figure 293: Simplified MSA of rhodium flows in the EU for 2012. (BIO Intelligence Service, 2015a)**

The overall EU supply chain of the PGMs is described in the general PGM factsheet. The supply chain for rhodium is complex and challenging to quantify. Rhodium supplies originate from both primary and secondary sources. Refineries in the EU process a wide range of rhodium-bearing materials emanating from European and overseas sources. These include end-of-life products, chiefly autocatalysts, and manufacturing waste (new scrap). By-products and residues from the non-ferrous mining, processing and manufacturing industries also contribute to supply.

There is no production of rhodium from mines in the EU; thus, the EU is 100% reliant on imports for rhodium derived from primary sources (European Commission, 2017). Nevertheless, as the EU is a significant producer of refined rhodium from primary and, mainly, from secondary materials collected domestically or imported, the actual dependency on imports is lower.

#### *EU supply chain of ruthenium*

The supply chain of the PGMs is described in the general PGM factsheet. The supply chain for ruthenium in the EU is complex and challenging to quantify. Ruthenium supplies are derived from both primary sources and secondary sources. Refineries in the EU process a wide range of ruthenium-bearing materials emanating from European and overseas sources. These include end-of-life products and manufacturing waste (new scrap). By-products and residues from the non-ferrous mining, processing and manufacturing industries also contribute to the supply (European Commission, 2017).

There is no production of ruthenium from mines in the EU; hence, the import reliance is 100% for ruthenium originating from primary sources (European Commission, 2017). Nevertheless, the EU is a significant producer of refined ruthenium from primary and, mainly, secondary materials collected domestically or imported, hence, the actual import dependency is lower.



## 19.7.2 Supply from primary materials

### 19.7.2.1 Geology, resources and reserves

#### *Geology, resources and reserves of PGMs in general*

**Geological occurrence:** The PGMs are among the rarest elements on Earth. Their abundance in the Earth's upper continental crust ranges from 0.022 parts per billion (ppb) for iridium to 0.52 ppb for palladium. According to data reported by (Rudnick and Gao, 2014), the overall PGM (for platinum, palladium, osmium, iridium, and ruthenium) abundance in the upper continental crust is 1.5 ppb, and in the bulk continental crust 3.7 ppb. PGMs are enriched in ultramafic rocks, such as peridotite, in which platinum and palladium concentrations are commonly 10-20 ppb (BGS, 2009).

The six PGMs occur together in nature, typically associated with nickel and copper. They are predominantly found either in base-metal sulphide minerals, or in a wide variety of PGM-bearing minerals bonded with one another, with other metals in alloy form, or with elements such as sulphur, arsenic, antimony and tellurium; hence, they are mined simultaneously from the same ore deposit as the main or by-product. In the cases, they are the main product, platinum or palladium is the main economic driver supporting the extractive operations while the other PGMs are by-products that make a minor revenue contribution. When PGMs are produced as a by-product (e.g. of nickel production), they are making a significant contribution to the overall economics of the operation (Yang *et al.*, 2018).

Enrichment of PGM concentrations occurs in deposits of several types developed in a limited range of geological settings. Mineable deposits of PGMs are scarce, and most PGM-bearing ores are extremely low-grade. Ore grades range typically from 1 to 10 grams (PGE and gold content) per tonne in the main commercial deposits in South Africa, Russia, and Zimbabwe (Zientek *et al.*, 2017). Deposits associated with commercial grades of PGM are of several types, mainly found in mafic or ultramafic rocks where the PGMs have been concentrated as a result of igneous processes (Mudd, Jowitt and Werner, 2018). The majority of global PGM resources and reserves are hosted in two deposit classes: the PGM-dominant class and the nickel-copper sulphide class.

The PGM-dominant class has platinum as the main economic product, generally with lesser amounts of palladium and rhodium production. Two types of PGM-dominant ores account for the majority of PGM production, the Merensky Reef type and the Chromitite reef type, both of which are best developed in the Bushveld Igneous Complex in South Africa (Gunn, 2014). The Merensky Reef type comprises extensive, laterally continuous, thin layers (termed 'reefs') in large layered mafic-ultramafic intrusions. Current mill-head grades of the Merensky Reef are typically 4-7 parts per million (ppm) of "6E" (i.e. combined platinum+palladium+rhodium+ruthenium+iridium+gold) or 4-6 ppm of combined platinum, palladium, rhodium and gold ("4E"), with a platinum-palladium-ratio between 2.0 : 1 and 2.5 : 1 at the largest operating mines (IPA Industrial expert, 2019). Similar deposits are mined in the Great Dyke in Zimbabwe and the Stillwater Complex in the United States. The Chromitite reef type has a similar morphology to the Merensky Reef, but it comprises thin continuous layers of chromite. Typical mined 4E grades (i.e. platinum+palladium including rhenium, and gold) are in the range 2.5 ppm to 4 ppm with a platinum-palladium-ratio of 2 : 1 (IPA Industrial expert, 2019) and significantly higher amounts of rhodium, ruthenium and iridium in comparison to the Merensky Reef (Hagelüken, 2019). The most important development of this type of mineralisation is found in the UG2 Chromitite in the Bushveld Igneous Complex, which is the largest repository of known PGM resources in the world.

A third type of platinum-palladium-bearing mineralisation, which is gaining in economic importance, is known as the Contact type. PGM grades typically range from 1 ppm to

4 ppm, and copper and nickel are produced as by-products because of the low-grade mineralisation. This type is best developed on the northern limb of the Bushveld Igneous Complex, known as the Platreef, although other deposits assigned to this class are also found in Canada, United States and Finland (Portimo). Finally, a fourth type of PGM-dominant deposits is the dunite pipes (e.g. Onverwacht, Bushveld Complex in South Africa), with high-grade platinum mineralisation in dunites, typical grades ranging from 3 ppm to 2,000 ppm platinum+palladium, but largely worked out and no longer mined (Viljoen, 2016, Gunn, 2014).

The nickel-copper-dominant deposits, in which the PGMs are associated with sulphide ores (mainly pyrrhotite, chalcopyrite and pentlandite), are found in various geological settings related to a range of igneous processes. This type of deposits is mined primarily for the value of nickel and copper, but with a significant contribution to their value by cobalt, gold, silver, PGMs etc., which are recovered as by-products when they occur at economically recoverable amounts. PGM grades can be up to 10 ppm, with a platinum-palladium- ratio less than one (Gunn, 2014, Hagelüken, 2019). The deposits mined in the Norilsk-Talnakh district of the Taimyr Peninsula in Russia is the most important example. Norilsk is one of the world's largest producers of nickel and, as some of the ores are very rich in PGM, it is the largest palladium producer in the world and an important platinum producer. The average grade of reserves is 5.54 ppm 6E (4.25 ppm palladium and 1.13 ppm platinum), with a platinum-palladium- ratio ranging typically from 0.2 to 0.4 in the different ore fields and deposits (Nornickel, 2018). Other economically important resources of PGM in magmatic nickel-copper sulphide deposits are found in the Sudbury Igneous Complex of Canada, the Kambalda area of Western Australia, the Pechenga district of Russia and Jinchuan in China (Gunn, 2014).

The 'minor' PGMs (rhodium, ruthenium, iridium and osmium) are generally present in platinum-palladium ores in tiny amounts, rarely exceeding a few per cent of the total PGM content. However, the proportion of iridium, rhodium and ruthenium in the UG2 ore is significantly greater than in the Merensky Reef, and it may exceed 20% (IPA Industrial expert, 2019). Consequently, as mining of the UG2 has increased markedly in recent decades, so the potential availability of these PGMs has enlarged (European Commission, 2017a).

The H2020 SCRREEN project provided a compilation of the available information on the geological occurrences of PGMs in Europe (Lauri *et al.*, 2018). The main points are summarised below:

- In Finland, PGM occurrences are identified in a number of deposits. In most cases, the PGMs are only potential companion or minor by-products. The most important are located in the PGM-dominant, layered intrusion-hosted deposits of the Arctic Platinum Project in northern Finland grading on average at 1.47 ppm palladium and 0.36ppm platinum (Arctic Platinum, 2019). Notable PGM occurrences are found in the magmatic nickel and nickel-copper deposits of Kevitsa and Sakatti;
- In Bulgaria and Greece, the Elatsite and the Skouries porphyry copper deposits respectively are reported to be enriched in PGMs, though at very low levels (the grade of Elatsite deposits is at 0.0197 ppm platinum+palladium containing around 7 tonnes of platinum+palladium, and the average grade of the Skouries 2 deposit is at 0.047 ppm platinum+palladium containing about 23 tonnes platinum+palladium). As the dominant PGM minerals are associated with copper sulphides, they will probably follow copper in processing and could be recovered at the refinery stage as by-products;
- In Poland, the minor PGM production from the Lubin mines indicates the PGM potential of the Kupferschiefer deposits;
- In Germany, PGM mineralisation similar to that in the Polish Kupferschiefer has been described within the Mansfeld/Sangerhausen district;

- In Portugal and Spain, mafic-ultramafic intrusion-hosted nickel deposits may contain a small PGM potential in the Ossa-Morena and Aguablanca zones respectively, that could be recovered as by-products. A low grade of PGM is associated with the sulphide minerals of the nickel-copper ore extracted in Aguablanca mine in Spain grading at 0.47 ppm PGM; in 2011 the deposit contained about 85 tonnes palladium and 2 tonnes platinum. However, there is no information regarding how much of the Pt and Pd is retained in the nickel and copper concentrates and whether they are actually recovered at the refining stage;
- PGM are potentially contained within copper-nickel occurrences in mafic-ultramafic rocks in Cyprus, and nickel and nickel-copper deposits in Sweden.
- Greenland hosts both reef-type mineralisation and dunite-related PGM occurrences.

**Global resources and reserves:** It is difficult to obtain reliable global resource and reserve estimates for the PGMs as a group, or individual members of the group. Obstacles are the variability between reporting standards used, the fact that the PGM mineralisation may be aggregated in different and incomparable ways (i.e. platinum+palladium+rhodium or platinum+palladium+rhodium+gold), and because of the dynamic nature of resources and reserves being subject to continual revision, as exploration and mining proceed and market conditions change. Furthermore, the terms reserves and resources are often confused and used incorrectly, thus making compilations on national or regional scales complicated (European Commission, 2017a).

The United States Geological Survey (USGS) estimates global PGM resources to be more than 100,000 tonnes contained metal (USGS, 2019). (Mudd, Jowitt and Werner, 2018) summarised global PGM mineral resources in a detailed study of publicly available data for 2015 as reported by companies. A figure of 105,682 tonnes of total mineral resources of contained PGMs ("4E" data, i.e. consisting of platinum+palladium+rhodium+gold) is derived. Approximately two-thirds (68%) of the total PGM resources are located in South Africa, followed by Russia (17%), and Zimbabwe (9%). Likewise, the French Geological Survey compiled company data for 2012 and estimated global resources of PGM (platinum+palladium+rhodium) at 93,530 tonnes of which 71% was located in South Africa, 15% in Russia and 8% in Zimbabwe (BRGM, 2014).

**Table 115: World resources of PGMs**

Country	Source: (BRGM, 2014)		Source: (Mudd, Jowitt and Werner, 2018)	
	Year 2012		Year 2015	
	PGM <sup>203</sup> Resources (tonnes)	Percentage of total (%)	PGM <sup>204</sup> Resources (tonnes)	Percentage of total (%)
South Africa	66,749	71	72,201	68
Russia	14,071	15	17,793	17
Zimbabwe	7,764	8	9,184	9
USA	1,683	2	2,438	2
Canada	1,718	2	2,059	2
Finland	NA	NA	891	1
Greenland	NA	NA	469	<0.5
Australia	NA	NA	274	<0.5
Other countries	1,544	2%	352	<0.5
World total	93,530	100	105,682	100

<sup>203</sup> Pt+Pd+Rh

<sup>204</sup> Pt+Pd+Rh+Au

Global reserves of PGMs are estimated at 69,000 tonnes by the United States Geological Survey, with over 90% located in South Africa (Table 116). However, according to (Mudd, Jowitt and Werner, 2018), in 2015 global reserves of PGMs (platinum+palladium+rhodium+gold) were 16,775 tonnes, of which 64% were found in South Africa, 23% in Russia, 4% in Zimbabwe and 4% in the United States. Similarly, the French Geological Survey (platinum+palladium+rhodium) estimated a global PGM reserve of 14,582 tonnes based on company data for 2012. About 70% of the reserves was located in South Africa, 15% in Russia and 7% in Zimbabwe (BRGM, 2014). The above differences are due to the fact that the USGS reports much larger reserves for PGM in South Africa; 63,000 tonnes of PGMs are quantified by the USGS as South African reserves for the year 2018, while according to data compiled by (BRGM, 2014) and (Mudd, Jowitt and Werner, 2018), South African reserves are about 10,500 tonnes. The above differences compared to the USGS assessment is due to the fact that the USGS values for South Africa are derived from national reporting, despite not being strictly code-based reserves (Mudd, Jowitt and Werner, 2018).

**Table 116: World reserves of PGM**

Country	Source: (USGS, 2019)		Source: (Mudd, Jowitt and Werner, 2018)	
	Year 2018		Year 2015	
	PGM Reserves (tonnes) (rounded)	Percentage of total (%)	PGM Reserves (tonnes)	Percentage of total (%)
South Africa	63,000	91	10,790	64
Russia	3,900	6	3,932	23
Zimbabwe	1,200	2	747	5
USA	900	1	727	4
Canada	310	<1	504	3
Finland	NA	-	75	<0.5
World total	69,000	100	16,775	100

**EU resources and reserves:** PGM mineral resources and reserves compliant with an international reporting code are reported for Finland (Lauri *et al.*, 2018)(FODD, 2017). In particular:

- *The Arctic Platinum Project* in South Lapland holds the largest PGM single resource, with the PGM-dominant deposits of Konttijärvi and Ahmavaara jointly having a total (NI-compliant) resource of 225 tonnes palladium and 52 tonnes platinum (FODD, 2017);
- Other PGM resources occur in the following large, nickel-copper -dominant deposits: the active *Kevitsa* nickel-copper mine, with PERC-compliant reserves at 25 tonnes platinum and 16 tonnes palladium at the end of 2018 (Boliden, 2019b); the *Sakatti* deposit with indicated and inferred resource of 22 tonnes palladium and 28 tonnes platinum (JORC-compliant); possibly, the active *Talvivaara* mine with non-compliant inferred PGM resource of 38 tonnes palladium and 28 tonnes platinum.

According to the Fennoscandian Ore Deposit database, at the end of 2017, 34 deposits in Finland contained a total resource of 717 tonnes palladium and 285 tonnes of platinum.

## *Geology, resources and reserves of individual PGMs*

### *19.7.2.1.1.1 Geology, resources and reserves of iridium*

**Geological occurrence:** The geological occurrence of iridium is also discussed in the general PGM Factsheet.

The PGM are among the least abundant elements in the Earth's crust. Iridium is one of the rarest metals in nature, with an abundance in the Earth's crust reported as 0.037 parts per billion (ppb) by weight, and in the upper crust 0.022 ppb (Rudnick and Gao, 2014). The iridium grade in PGM ores is significantly lower than that of platinum and palladium.

Iridium is a co-product of platinum and palladium. The majority of iridium is derived from mafic-ultramafic igneous complexes like the Bushveld Igneous Complex in South Africa and the Great Dyke in Zimbabwe, in which iridium is produced as a co-product from platinum mining. According to background data sourced from (S&P Global, 2018a) (S&P Global, 2018b), iridium occurrence is associated with the 54% of the total global platinum+palladium resources and reserves, of which the PGM-dominant deposits account for about 79% (split into 73% in South Africa and 6% in Zimbabwe), whereas the nickel-copper -dominant deposits account for 21% (split into 20% in Russia and 1% in Canada).

No information is available for iridium geological occurrences or iridium concentration in PGM deposits in the EU.

**Global resources and reserves:** There are no global or national resource or reserve data for iridium in the public domain. Iridium data are typically presented in combination with other PGM (see PGM factsheet for more details).

**EU resources and reserves:** Resources of iridium do not exist in the EU, or are not available in the public domain.

### *19.7.2.1.1.2 Geology, resources and reserves of palladium*

**Geological occurrence:** The geological occurrence of palladium is also discussed in the general PGM factsheet.

The abundance of palladium in the Earth's crust is reported by various sources to range from 1.5 parts per billion (ppb) by weight (Rudnick and Gao, 2014) to approximately 5 ppb (BGS, 2009), whereas in the upper crust the average abundance is reported as 0.52 ppb (Rudnick and Gao, 2014).

Of the deposits in operation worldwide, palladium is mostly a by-product; however, the main product, to which palladium is associated, varies across countries. Palladium is predominantly a by-product of nickel and copper mining in the Russian Federation, Canada and Finland. In South Africa and Zimbabwe, palladium is mostly a co-product of platinum mining, while in the United States palladium is the main product mined from PGM-dominant deposits. In 2017, 49% of the world's palladium mine production was associated with Ni-Cu-dominant deposits and 51% with PGM-dominant deposits (background data from (S&P Global, 2018)).

The geological occurrence of palladium in the EU is discussed in 0.

**Global resources and reserves:** Palladium resources are typically reported in combination with other PGM, most commonly with platinum and sometimes with rhodium and/or gold. See the PGM factsheet for more details. Some mining companies publish separate resource and reserve data for palladium in individual deposits. An estimate based on data published by the French Geological Survey (BRGM) and Norilsk Nickel is that global reserves of palladium are 7,200 tonnes in palladium content in 2017, with most of them

located in South Africa (43.5%) and Russia (40.8%). Table 117 presents the estimate for global reserves of palladium.

**Table 117: World reserves of palladium in 2017 (BRGM, 2017a) (Nornickel, 2018)**

Country	Palladium Reserves (tonnes of Pd content) (rounded values)	Percentage of the total (%)
South Africa	3,130	43.5
Russian Federation <sup>205</sup>	2,940	40.8
United States	450	6.3
Zimbabwe	370	5.1
Canada	280	3.9
Other countries (unspecified)	30	0.4
World total	7,200	100

**EU resources and reserves:** Table 118 and Table 119 show available data for palladium resources and reserves.

**Table 118: Palladium resources data in the EU**

Country	Classification	Quantity (million tonnes of ore)	Grade (g/t)	Reporting code	Reporting date	Source
Finland	Measured	23.6	0.11	PERC	12/2018	(Boliden, 2019)
	Indicated	114.9	0.09		12/2018	(Boliden, 2019)
	Inferred	19.2	0.08		12/2018	(Boliden, 2019)
Finland <sup>1,2</sup>	All (Measured-Indicated-Inferred)	312.8	0.79	NI 43-101	12/2017	(FODD, 2017)
Finland <sup>2</sup>	All (Measured-Indicated-Inferred)	1,989	0.09	JORC	12/2017	(FODD, 2017)
Finland <sup>2</sup>	Historic Resource Estimate	214.7	1.11	None	12/2017	(FODD, 2017)
Sweden	Historic Resource Estimate	0.2	0.4	None	12/2017	(FODD, 2017)

<sup>1</sup>NI 43-101 compliant resources of the Kevitsa (Boliden) mine are not included, as they are reported separately in the table  
<sup>2</sup>Mineral resources of closed mines, as the FODD database indicates them, are included.

**Table 119: Palladium reserves data in the EU**

Country	Classification	Quantity (million tonnes of ore)	Grade (g/t)	Pd content (t)	Reporting code	Reporting date	Source
Finland	Proven	62.5	0.12	7.5	PERC	12/2018	(Boliden, 2019)
	Probable	66.1	0.14	8.8			

<sup>205</sup> Background data from (Nornickel, 2018)

### 19.7.2.1.1.3 Geology, resources and reserves of platinum

**Geological occurrence:** The geological occurrence of platinum is also discussed in the general PGM factsheet.

As all PGMs, platinum is a scarce natural resource. Platinum's abundance in Earth's crust is reported from 1.5 ppb by weight (Rudnick and Gao, 2014) to approximately 5 ppb (BGS, 2009), whereas in the upper crust as 0.5 ppb (Rudnick and Gao, 2014).

In addition to the significant resources derived from mafic-ultramafic igneous complexes like the Bushveld Igneous Complex in South Africa and the nickel sulphide deposits in Russia and elsewhere, platinum is also known to be enriched to potentially economic concentrations in several other geological settings (Gunn, 2014). Small-scale production from placer deposits has taken place for many decades in the Urals and the Russian Far East, in Colombia, Alaska and New Zealand. High tenor platinum values are also known in Alaskan-Ural type complexes, in ophiolites and hydrothermal veins, but these are not currently worked for platinum. Low-grade platinum enrichments are also well known in laterites, unconformity-related gold-uranium deposits, porphyry deposits, black shales and carbonatites and other alkaline complexes. These settings have not been the source of platinum production to date, but platinum might in the future become available as a by-product of other metals in deposits of these types.

Concerning the main deposits in operation globally, platinum is mostly the main product mined in South Africa and Zimbabwe, where palladium and other PGM are the secondary co-products. In the Russian Federation and Canada platinum is typically a by-product of copper and nickel, but produced at lower quantities than palladium. In the United States, platinum is a co-product of palladium production. In 2017, 83% of the world platinum mine production was associated with PGM-dominant deposits and 17% with nickel-copper-dominant deposits (background data from(S&P Global, 2018)).

The geological occurrence of platinum in the EU is discussed in chapter 0.

**Global resources and reserves:** Platinum resources are typically reported in combination with other PGM, most commonly with palladium and sometimes with rhodium and/or gold (See the PGM factsheet for more details). Some mining companies publish separate resource and reserve data for platinum in individual deposits. According to data published by the French Geological Survey (BRGM), global reserves of platinum are estimated to 13,000 tonnes in 2017 (BRGM, 2017b), with most of them located in South Africa (81.7%), followed by Zimbabwe (7.3%) and Russia (5.9%). Table 120 presents the estimated global reserves of platinum.

**Table 120: World reserves of platinum in 2017. (BRGM, 2017b)**

<b>Country</b>	<b>Platinum Reserves (tonnes of Pt content) (rounded values)</b>	<b>Percentage of the total (%)</b>
South Africa	10,620	81.7
Zimbabwe	950	7.3
Russian Federation	780	5.9
United States	210	1.6
Canada	210	1.6
Other countries (unspecified)	230	1.9
World total	13,000	100

**EU resources and reserves:** Available data for platinum resources and reserves are shown in Table 121 and Table 122 below.

**Table 121: Platinum resources data in the EU**

Country	Classification	Quantity (million tonnes of ore)	Grade (g/t)	Reporting code	Reporting date	Source
Finland	Measured	23.6	0.17	PERC	12/2018	(Boliden, 2019)
	Indicated	114.9	0.14		12/2018	(Boliden, 2019)
	Inferred	19.2	0.13		12/2018	(Boliden, 2019)
Finland <sup>1,2</sup>	All (Measured-Indicated-Inferred)	312.8	0.19	NI 43-101	12/2017	(FODD, 2017)
Finland <sup>2</sup>	All (Measured-Indicated-Inferred)	1,989	0.05	JORC	12/2017	(FODD, 2017)
Finland <sup>2</sup>	Historic Resource Estimates	126.3	0.77	None	12/2017	(FODD, 2017)

<sup>1</sup>NI 43-101 compliant resources of the Kevitsa (Boliden) mine are not included, as they are reported separately in the table  
<sup>2</sup>Mineral resources of closed mines, as the FODD database indicates them, are included.

Also, the European Minerals Yearbook reports 5.08 Mtonnes of indicated, JORC-compliant resources in Greenland at a grade of 0.06 grams per tonne (g/t) (Minerals4EU 2019).

**Table 122: Platinum reserves data in the EU**

Country	Classification	Quantity (million tonnes of ore)	Grade (g/t)	Pt content (t)	Reporting code	Reporting date	Source
Finland	Proven	62.5	0.18	11.3	PERC	12/2018	(Boliden, 2019)
	Probable	66.1	0.21	13.9			

#### 19.7.2.1.1.4 Geology, resources and reserves of rhodium

**Geological occurrence:** The geological occurrence of rhodium is also discussed in the general PGM Factsheet

The PGMs are among the rarest elements in the Earth's crust; rhodium is a scarce metal with an abundance of approximately 1 ppb by weight in the Earth's crust (BGS, 2009). The rhodium grade in PGM ores is lower than that of platinum and palladium.

Rhodium is a co-product of platinum and palladium mining. Over 80% of rhodium's world primary production is derived from PGM-dominant deposits in South Africa, in which PGMs are the main economic components. In particular, the major part of rhodium is extracted from the mafic-ultramafic Bushveld Igneous Complex in South Africa, namely from two horizons: the Merensky Reef and the UG2 Chromitite. The UG2 Chromitite deposit of the Bushveld Complex is particularly rich in rhodium (0.3-0.6 ppm) (Gunn, 2014), and accounts for more than half of total rhodium production from South Africa (Johnson Matthey, 2016). Other sources of rhodium are the PGM-dominant deposit of Great Dyke in Zimbabwe, as well as the nickel-copper sulphide deposits in Canada (Sudbury) and Russia (Norilsk) where rhodium is extracted as a by-product together with other PGM (Gunn, 2014). According to background data from (S&P Global, 2018a)(S&P Global, 2018b), the platinum-palladium deposits with rhodium occurrences account for 91% of the global joint platinum+palladium resources and reserves, of which the PGM-dominant deposits represent approximately 84% (split into 79% in South Africa and 5% in Zimbabwe), and the nickel-copperNi-Cu-dominant deposits account for 16% (divided in 12% in Russia and 4% in North America).



In the EU, rhodium grades of about 0.1 ppm are reported in two small, non-exploited deposits in Finland (Paasivara, Ala-Penikkavaara) having a total, non-compliant resource estimate of 780 kilogram of rhodium (FODD, 2017). In Europe, exploration drillings in the past have intersected rhodium-rich mineralisation of up to 1.0 ppm platinum+palladium+rhodium in Greenland (Lauri *et al.*, 2018).

**Global resources and reserves:** Global or national resource or reserve data for rhodium are not available in the public domain. Rhodium data are generally presented in combination with other PGMs, most commonly platinum and palladium, and sometimes with gold. In the general PGM factsheet, more information about mineral resources and reserves is provided.

**EU resources and reserves:** The following table presents available data on rhodium resources in the EU. Rhodium reserves do not exist.

**Table 123: Rhodium resources data for the EU**

Country	Classification	Quantity (million tonnes of ore)	Grade (g/t)	Reporting code	Reporting date	Source
Finland <sup>206</sup>	Historic Resource Estimates	8.6	0.11	None	12/2017	(FODD, 2017)

#### 19.7.2.1.1.5 Geology, resources and reserves of ruthenium

**Geological occurrence:** The geological occurrence of ruthenium is also discussed in the general PGM factsheet.

The PGM are among the least abundant elements, and ruthenium is one of the rarest metals in nature. Its abundance in the Earth's crust is reported to be 0.57 ppb by weight and in the upper crust 0.34 ppb (Rudnick and Gao, 2014). The ruthenium content in PGM ores is significantly lower than that of platinum and palladium.

Ruthenium is a co-product of platinum and palladium. The principal primary sources of ruthenium are the PGM-dominant deposits located in mafic-ultramafic igneous complexes like the Bushveld Igneous Complex in South Africa and the Great Dyke in Zimbabwe, where ruthenium is produced as a co-product of platinum mining. According to background data from (S&P Global, 2018a)(S&P Global, 2018b), ruthenium's occurrence is reported for the 51% of the global joint platinum+palladium resources and reserves, of which the PGM-dominant deposits account for 78% (split into 72% in South Africa and 6% in Zimbabwe), whereas the nickel-copper -dominant deposits account for 22% (split into 21% in Russia and 1% in Canada).

No information is available for geological occurrences of ruthenium in PGM deposits in the EU.

**Global resources and reserves:** There are no global or national resource or reserve data for ruthenium in the public domain. Data for ruthenium are typically presented in aggregated form with other PGMs (seechapter 0).

**EU resources and reserves:** Resources of iridium do not exist in the EU, or are not reported in the public domain.

<sup>206</sup> Mineral resources of closed mines, as reported by the FODD database, are included

### 19.7.2.2 Mining and metallurgical extraction

#### *Exploration and new mine development projects in the EU*

Active exploration projects are registered in Finland and Sweden by (S&P Global, 2018). The most advanced one, currently at pre-feasibility/scoping stage, is the palladium-rich polymetallic (platinum-palladium-gold-copper-nickel) Arctic Platinum Project in northern Finland (Arctic Platinum, 2019).

#### *Mining of PGMs*

PGM-bearing deposits are typically mined by underground or, less usually, by open-pit methods. The selection depends on size, grade and morphology of the orebody.

Most of the PGM mines in South Africa operate at depth below 500 metres and up to 2.2 kilometres. Mining is labour-intensive by conventional drilling and blasting techniques, though attempts are being made to introduce more mechanisation into the workplace, as the PGM-rich layers are very narrow (typically less than one metre thick) (IPA, 2015d, European Commission, 2017a, Hagelüken, 2019). Underground mining is also employed at the Norilsk-Talnakh mines in Russia and several sites in Zimbabwe, Canada and the United States (European Commission, 2017a).

Surface mines are generally cheaper and safer to operate than underground mines. Open-pit mining is most appropriate for near-surface (< 100 metres depth), lower-grade, steeply dipping, or massive ore bodies where large-scale surface excavations would not cause significant environmental impact (European Commission, 2017a). Examples of surface mining operations include the Mogalakwena mine in South Africa (Merschel and Krämer, 2018), and Norilsk-I "South Cluster" operations in Russia which involve both open-cast and underground mining (IPA Industrial expert, 2019).

As PGMs are mined at very low concentrations compared with most other metals, a number of mineral processing steps are required after mining to increase the PGM content. A range of physical and chemical concentration techniques are applied based on the mineralogical features of the individual ore including crushing and milling, froth flotation, and in some cases magnetic separation and dense media separation (BGS, 2009). Concentration is typically carried out at, or close to, the mine site (Gunn, 2014). Subsequent smelting and refining may be carried out at or near the mine, or concentrate may be transported to a centralised facility for processing to metal.

Different processes are used for processing sulphide-poor ores (i.e. Merensky and UG2) and sulphide-rich ores (e.g. Norilsk). In the PGM-dominant deposits, the crude ore is initially crushed and ground to facilitate separation of PGM-bearing and gangue minerals. Magnetic or dense media separation can also be applied after comminution to optimise recovery, depending on the associated minerals (sulphides, chromite or silicates). Subsequently, the liberated sulphide mineral grains which host the PGM are concentrated by froth flotation (Gunn, 2014). The grades of the mined ores from the Bushveld Igneous Complex, the world's chief source of PGMs, are generally in the range 2-5 ppm of combined platinum+palladium. The typical grades currently mined are about 3-4 ppm platinum+palladium in the Merensky Reef and 2-3 ppm platinum+palladium in UG2 (IPA Industrial expert, 2019). In general, for most mining companies or projects the average ore grades have been gradually declining, which is a function of the mix of reef types mined (Merensky/UG-2/Platreef) and the economics of mining, i.e. shallower but lower grade ores versus deeper but higher grade ores (Mudd, Jowitt and Werner, 2018).

Typical grades of the concentrate range from 100 ppm to 200 ppm PGM (Merschel and Krämer, 2018), but can be up to 1,000 ppm PGM (Johnson Matthey, 2019b); grades of 2,100 ppm PGM for concentrates from the Stillwater operations in the United States are also reported (Yang *et al.*, 2018).

Nickel-copper -dominant ores are treated differently due to their higher sulphide content and different mineralogy; several processing routes are applied as sulphide concentration, and ore texture vary considerably (Gunn, 2014).

#### *Metallurgical extraction of PGMs*

Metallurgical processing and refining to produce high-purity PGM products is a complex, costly, and lengthy process; it may take up to six months to produce refined metal from the time the first PGM-bearing ore is extracted at the mine (IPA, 2015e). The applied techniques differ from company to company (Yang *et al.*, 2018), the details of which are not disclosed as commercial secrets (Gunn, 2014).

##### *19.7.2.2.1.1 Enrichment of concentrates*

The PGM concentrates are too low-grade to be refined directly and have to undergo an enrichment step prior to refining. However, their value is so high that this enrichment step has to ensure minimum losses (Yang *et al.*, 2018). The enrichment process typically consists of a pyrometallurgical and a hydrometallurgical step (Yang *et al.*, 2018). This process typically occurs close to the mining site due to the large tonnages of materials that require processing (European Commission, 2014).

For PGM concentrates produced by the PGM-dominant ores of South Africa, the following processes are generally applied (Yang *et al.*, 2018, Merschel and Krämer, 2018, Gunn, 2014, Jones, 2005):

- (i) Smelting and matte production: The dried flotation concentrate is smelted in electric furnaces at temperatures about 1,350 °C, although higher temperatures maybe are needed for UG2 concentrates (Gunn, 2014). The PGM and base-metal sulphides accumulate in a matte, while a slag containing unwanted minerals is discarded. The matte is then transferred to converters where it undergoes a process known as converting. This involves blowing air, or oxygen, into the matte to oxidise contained iron and sulphur. Silica is added to the matte to react with the oxidised iron to form a slag that can be easily removed, while the sulphur is collected from the off-gas to produce sulphuric acid. The converter matte consists of copper and nickel sulphide with smaller quantities of iron sulphides, cobalt and PGM. This is usually cast into ingots and is then sent to the base metal treatment plant. The typical PGM content of the converter matte is 0.2-0.4% PGM by weight (Merschel and Krämer, 2018);
- (ii) PGM concentrate production: The matte is transferred to the base metal refinery where it is magnetically separated and leached over several stages to separate base metals (e.g. nickel and copper). After the final leaching stage, a PGM concentrate is produced containing about 50% to 70% PGMs+gold (Merschel and Krämer, 2018).

Where PGMs are a by-product of nickel and copper production from nickel-copper-dominant ores, such as those in Russia and Canada, different treatments are applied due to the higher sulphide content and different mineralogy. The metallurgical process is designed around the main product (typically nickel) while maximising PGM recoveries (Yang *et al.*, 2018, Gunn, 2014).

The concentrate produced in Russia (Norilsk) undergoes roasting, smelting, and conversion to a copper-nickel- PGM matte. The matte is then treated in the base metal refinery by oxidation pressure leaching to produce concentrates of copper, nickel and cobalt. The copper concentrates, which contain all the PGMs and gold, are further treated by a combination of copper extractive metallurgy techniques, i.e. smelting to copper blisters and refining by electrowinning, to separate copper. The anode slimes are then combined with nickel slimes and other PGM-bearing concentrates and smelted again to

produce a PGM-bearing matte, which is pressure-leached to produce separately a concentrate of silver, a second one containing palladium and platinum, and a third one with the rest of the PGM (Gunn, 2014). Different processing routes are applied to nickel and copper PGM-bearing concentrates produced elsewhere. The various extractive metallurgy circuits used generate anode slimes and carbonyl process residues rich in PGMs, gold, and other metals, which are sent for PGM refining.

#### *19.7.2.2.1.2 Refining*

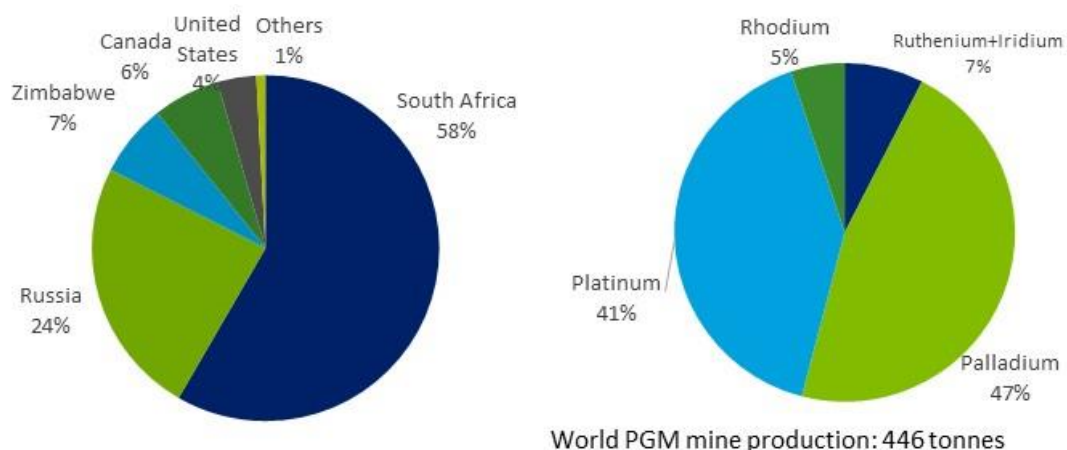
The PGM-bearing concentrate is transferred from the base metal refinery to the precious metal refinery for separation and purification of the PGMs and gold. Refining is known to involve a series of hydrometallurgical steps to separate and purify the PGMs.

The PGM concentrate is dissolved in hydrochloric acid and the six PGM are refined to a high level of purity by selective precipitation, or separation using a combination of techniques such as solvent extraction, distillation and ion-exchange. Gold and palladium are the first to be extracted, and rhodium usually the last. Iridium, ruthenium and osmium are separated at the end of the separation process, therefore, if there is no demand, part of these intermediates can be stored for future use (Angerer *et al.*, 2016). In South Africa, the time between the mining of the ore and production of pure metal typically ranges from around six weeks for palladium and up to 20 weeks for rhodium (Johnson Matthey, 2019b). Nickel, copper, cobalt, and silver may be obtained in the refining process as co-products. The refined PGMs have a purity of over 99.95%, and can be produced in several forms: ingot, grain or a fine powder known as "sponge".

#### **19.7.2.3 World and EU mine production**

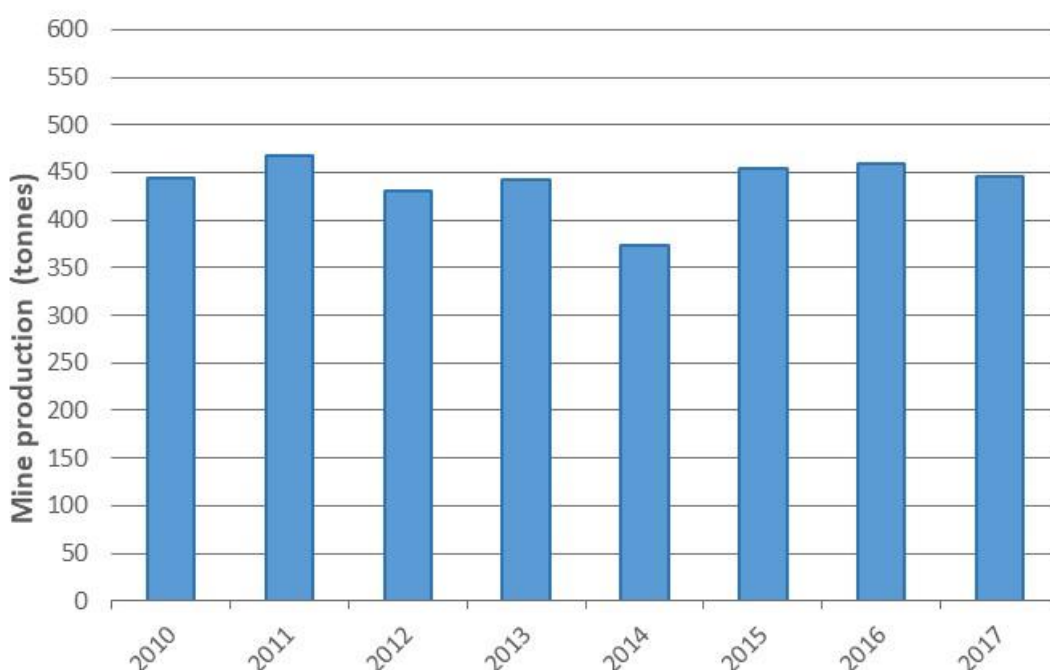
PGM mine production for 2017 is summarised in Figure 294. South Africa is the leading PGM supplier from primary sources accounting for 58% of the world's mine production. South Africa is the dominant world supplier of platinum and the 'minor' PGM, i.e. rhodium, ruthenium, iridium and osmium, and the second world producer of palladium. Russia is the second PGM world producer accounting for about 24% of total production in 2017, and it is the top world producer of palladium. The rest of the notable world producers consists of Zimbabwe, Canada and the US.

The world primary production of PGMs has remained relatively constant since 2010 ranging from 443 to 467 tonnes annually, though, with a noteworthy reduction in 2014 (Figure 295). South African production of platinum was hit by widespread strike action in 2014 when a six-month stoppage at western Bushveld operations resulted in the loss of over one million ounces of platinum production (Johnson Matthey, 2019a). However, South African production has been broadly stable since 2015 despite the closure of several high-cost shafts during this period (IPA Industrial expert, 2019).



World PGM mine production: 446 tonnes

**Figure 294: World mine production of PGM in 2017 per country (left) and per material (right). Background data<sup>207</sup> from (WMD 2019) (BGS, 2019)**

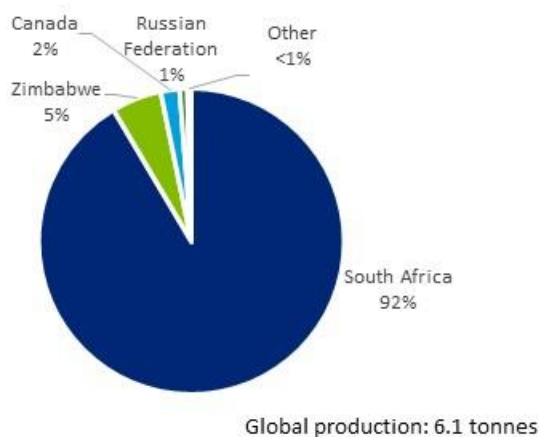


**Figure 295: Evolution of world mine production of PGMs from 2010 to 2017. Background data from (WMD 2019) (BGS, 2019)**

#### *World and EU mine production of iridium*

The world production of iridium is estimated to approximately six tonnes, much less than the annual production of the other PGM. Iridium supply is strongly dominated by South Africa, which accounted for about 92% of the total. Zimbabwe, Canada and Russia are contributing to the remainder of the global mine production with 5%, 2% and 1% respectively. There is no production of iridium from mines in the EU.

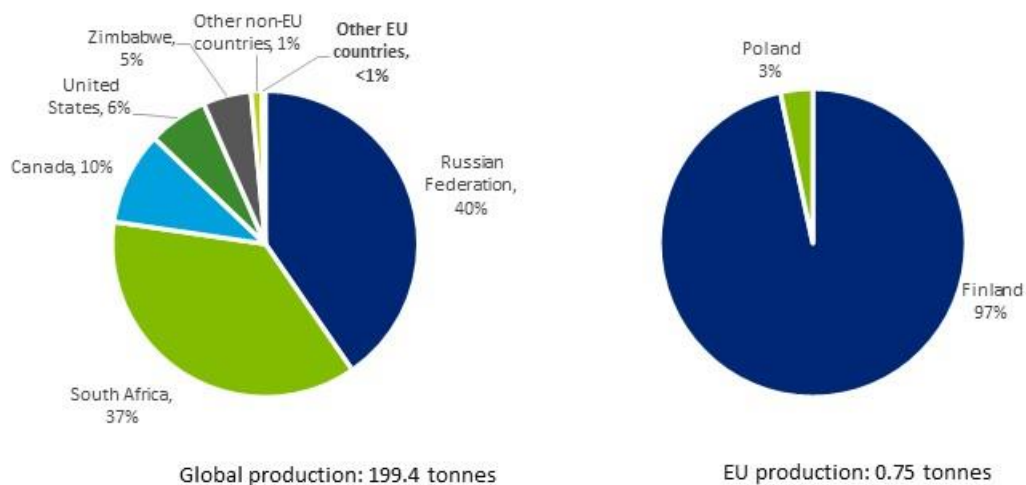
<sup>207</sup> WMD is the source for platinum, palladium and rhodium mine production. For other PGM, BGS was used as the source (“Other platinum metals”) after adjusting the values reported with the Rh mine production reported by WMD



**Figure 296: The distribution of global mine production of iridium. Average for the years 2012-2016. Estimation based on background data from (BGS, 2019) (WMD 2019) (Johnson Matthey, 2019a) (Girolami, 2012)(European Commission, 2017)**

*World and EU mine production of palladium*

The annual average world mine production of palladium in the period 2012-2016 was about 199 tonnes. Russia was the leading world producer with a share of 40% of the total. South Africa was the second most important producer (37% of total), followed by Canada (10%), the United States (6%), and Zimbabwe (5%). EU production accounts for only 0.4% of the global output.

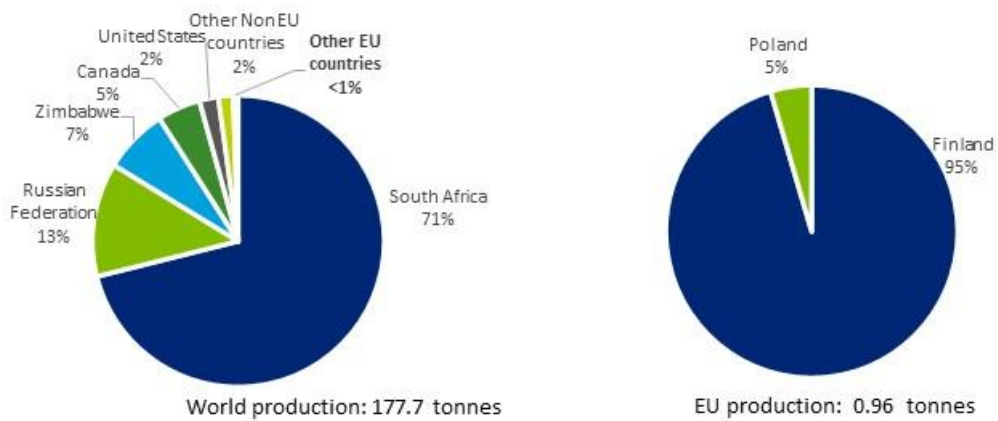


**Figure 297: World and EU mine production of palladium (average 2012-2016). Data from (WMD 2019) (BGS, 2019)<sup>208</sup>**

*World and EU mine production of platinum*

The annual average world mine production of platinum for the period 2012-2016 was about 178 tonnes. Global supply is dominated by South Africa, which accounted for about 71% of the total. Russia was the second most important producer (13% of total), followed by Zimbabwe (7%) and Canada (5%). Extraction in the EU accounts for only 0.5% of the global production.

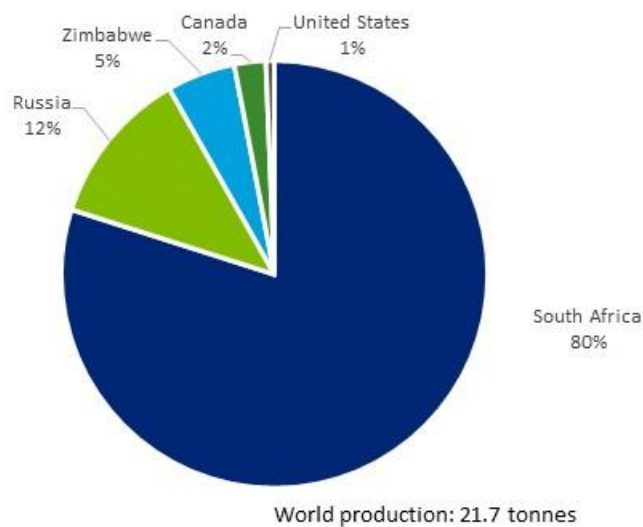
<sup>208</sup> for China



**Figure 298: World and EU mine production of platinum (average 2012-2016). Data from (WMD 2019) (BGS, 2019)<sup>209</sup>**

*World and EU mine production of rhodium*

The average annual world mine production of rhodium for the period 2012-16 was approximately 21.7 tonnes. Global supply is dominated by South Africa, which accounted for about 80% of the total. Russia was the second most important producer (12% of total), followed by Zimbabwe (5%), Canada (2%) and the United States (1%).

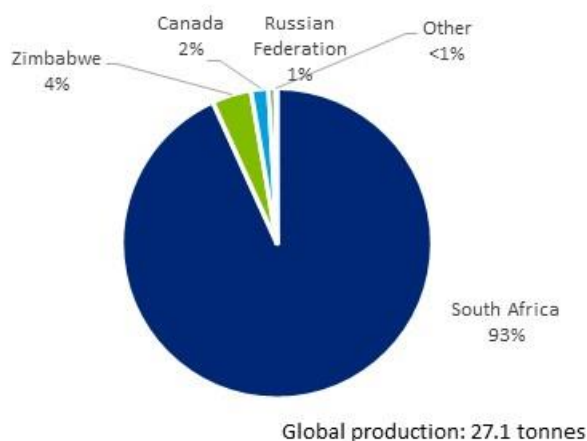


**Figure 299: The distribution of global mine production of rhodium, average 2012-2016. Data from (WMD 2019)**

*World and EU mine production of ruthenium*

The annual average mine production of ruthenium for the period 2012-2016 is estimated to about 27 tonnes. Global supply is strongly dominated by South Africa, which accounted for about 93% of the total. Zimbabwe was the second most important producer (4% of total), followed by Canada (2%), and Russia (1%) (Figure 300). There is no production of ruthenium from mines in the EU.

<sup>209</sup> For China



**Figure 300: The distribution of global mine production of ruthenium. Average for the years 2012-2016. Estimation based on background data from (BGS, 2019) (WMD 2019) (Johnson Matthey, 2019a) (Girolami, 2012)(European Commission, 2017)**

### 19.7.3 Supply from secondary materials/recycling

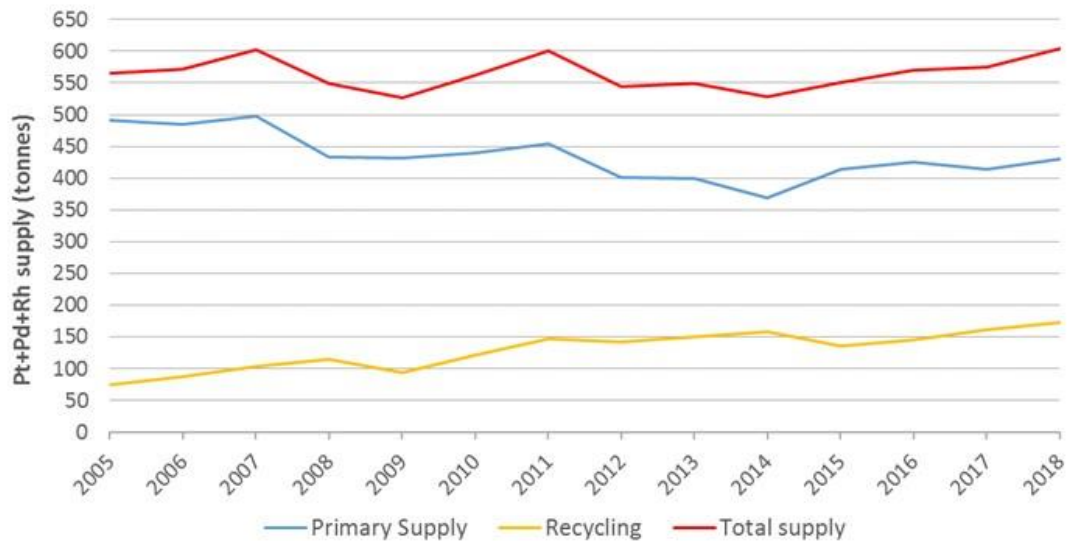
#### 19.7.3.1 Supply of PGMs in general from secondary materials

The PGMs are highly recyclable in technical terms due to their noble characteristics and durability in use, as well as because very high recovery rates of the metal content can be achieved once the PGM-containing scrap reaches a modern refining facility. In this case recovery rates for platinum and palladium of over 95% are technically attainable with current state-of-the-art techniques, while for rhodium, iridium and ruthenium the metallurgical yields are somewhat lower but still high (Hagelüken, 2014, Gunn, 2014, Sundqvist Ökvist *et al.*, 2018). In addition to the technical viability of recycling, secondary production from end-of-life products is attractive from an economic point of view as the PGM, like all precious metals, have a high intrinsic value (Hagelüken, 2014). Therefore, the potential for effective recycling is generally excellent, except in some applications and/or when used in minimal amounts (UNEP, 2011).

Besides the positive impact to the security of supply, PGM recycling brings environmental benefits. Secondary production of PGMs has lower environmental impacts than primary production due to the much higher PGM concentration in many end-of-life products compared to the low ore grades. For example, an autocatalyst may contain up to 2,000 g/t of PGM in the ceramic catalyst brick, and computer motherboards contain around 80 g/t palladium. This is significantly higher compared to 2-6 g/t of average grade in most PGM mines (Hagelüken, 2012)(IPA, 2015f).

The supply of PGMs from secondary materials is well established and has been growing steadily in recent years (see Figure 301) helping to manage the supply and demand dynamics and maintain the market in balance. Recycled platinum, palladium, and rhodium provide a significant proportion of the total supply, which is sufficient to balance the market closing the gap between mine production and consumption (Zientek *et al.*, 2017). In 2018, about 29% (173 tonnes) of the global supply of Pt+Pd+Rh was obtained through recycling (Johnson Matthey, 2019a), while in 2005 this proportion was 13% (74.5 tonnes) (Johnson Matthey, 2014). Concerning ruthenium and iridium, it is considered that the proportion of the metal supply produced from recycling is lower than for platinum, palladium, and rhodium, while literature does not acknowledge osmium being recycled in an industrial scale.

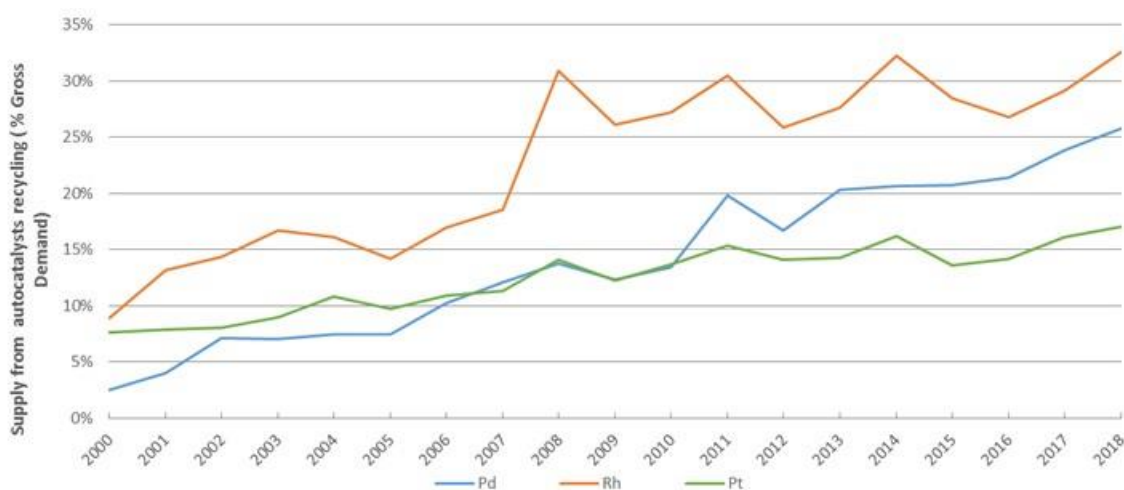




**Figure 301: Global supply of PGM (Pt+Pd+Rh) from mine production and recycling (2005–2018). Background data from (Johnson Matthey, 2019a) for 2014–2018, (Johnson Matthey, 2018) for 2013, and (Johnson Matthey, 2014) for 2005–2012.**

Technical challenges in the recycling of PGMs do exist, especially for complex products such as vehicles and computers. However, the main barrier to the effective recycling of PGM lies in ensuring that end-of-life products are collected appropriately and enter an efficient recycling chain. In open-loop recycling of end-of-life consumer products the rate achieved is critically dependent on numerous factors, such as the prevailing price and a host of others (e.g. market mechanism, consumer behaviour, relevant legislation) that influence the collection efficiency (Hagelüken, 2012)(Hagelüken, 2014). For example, declining steel scrap prices (as those prevailing between 2014 and 2016) affect negatively the number of end-of-life vehicles worldwide reaching scrapyards, leading to longer lifetime of vehicles and lower volumes of spent catalytic converters being removed for processing. Also, low PGM prices have a short-term adverse effect on recovery from autocatalysts as they may lead to stockpiling of catalyst scrap by collectors (Johnson Matthey, 2016)(Johnson Matthey, 2017)(Johnson Matthey, 2018). In the EU, the recycling of autocatalysts is impacted by the End-of-Life Vehicles (ELV) Directive (2000/53/EC), and Directive 2005/64/EC on the type-approval of motor vehicles with regard to their reusability, recyclability and recoverability, while the recycling of electronics is stimulated by the EU Waste Electrical & Electronic Equipment (WEEE) Directive (Directive 2012/19/EU).

Recycling of automotive catalysts is the most important contributor to secondary supply. 95% of the PGM content of spent autocatalysts can be recovered during the refining process using state-of-the-art recycling technologies (IPA, 2015f), and the global average recycling rate is estimated to be 50-60% (European Commission, 2017b). The contribution of autocatalysts' recycling to the security of supply is higher for rhodium. In the period 2014-2018, between 27% and 33% of total global demand for rhodium was supplied by autocatalysts recycling, whereas for platinum the proportion was 14-17% and for palladium 21-26%.



**Figure 302: Contribution of autocatalysts recycling to platinum group metals world market balance (2000-2018). Background data from (Johnson Matthey, 2019a) for 2014-2018, (Johnson Matthey, 2018) for 2013, and (Johnson Matthey, 2014) for 2005-2012**

Besides autocatalysts, other materials from end-of-life products, notably jewellery and electronic scrap, are used as feedstock to PGM recycling processes. Consumer items, such as automotive catalysts, jewellery scrap and electronic equipment, all rich in PGMs, may or may not enter the recycling stage. This forms an 'open-loop' system, in which losses of PGMs tend to be higher than in a closed-loop system, where PGM materials are collected at a very high rate or enter secondary production directly from industrial processes. Recycling rates in open-loop recycling are correspondingly lower, e.g. 5-10% in waste electrical and electronic equipment (WEEE).

PGM recycling from industrial applications typically follows a closed-loop system, in which the metal usually remains in the ownership of the industrial user, and metal recovered from scrap is subsequently reused in the same application (Hagelüken, 2012) (Johnson Matthey, 2019a). Typical examples are spent process catalysts used in the chemical and oil refining industry, as well as glassmaking equipment. New metal supply is only required to cover small life cycle losses and increased demand from market growth and new applications. End-of-life recycling rates in industrial applications are well over 80% (Hagelüken, 2014).

In some other cases, PGM uses are dissipative (e.g. medical applications, spark plugs, sensors) and are not available for recycling. In contrast, jewellery and investment items reach very high recycling rates due to their high value and PGM concentration (Hagelüken, 2012).

A complementary source of PGMs and other precious metals are industrial by-products of the non-ferrous metals mining, processing and manufacturing industries. These include various intermediate products and residues such as complex mining concentrates, slags, mattes, flue dust, ash, slimes and production waste from the electronics, glass, jewellery and chemical industries (European Commission, 2017a).

Secondary production processes vary widely depending on the specific material or combination of materials treated, the contaminants to be removed and the particular mix of PGMs for separation from any batch of feedstock (Cusano et al., 2017). The first step in secondary production is typically the pre-treatment of the feedstock (e.g. segregation, crushing, grinding, thermal treatment). The PGM-containing materials are then either smelted to a metal matte or dissolved to bring the PGMs into a solution. The concentrated

PGM output is further refined to recover individual metals separately in a pure form, identical in quality and purity to those from primary production. Although PGMs are relatively inert, the chemical properties and the reactivity of their compounds vary, allowing a variety of separation techniques to be used such as chemical precipitation, chemical dissolution, liquid-liquid extraction, distillation of tetroxides, ion exchange, electrolytic processes, pyrolysis or reduction of metallic chloride compounds to pure metal sponges. PGM refining is complex, and individual process stages may have to be repeated to achieve the required purity. PGM are generally refined together with gold and silver.

### 19.7.3.2 Supply of individual PGMs from secondary materials

#### *Supply of iridium from secondary materials*

Recycling makes an important and growing contribution to global PGM supply (see chapter 19.7.3.1).

Most iridium is used in closed-loop industrial applications (including process catalysts and electrodes) where losses are low and recycling rates high. A recycling rate of 40–50% is reported by (UNEP, 2011) and (Hagelüken, 2014) as typical. In most consumer goods the recycling rate of iridium is very low because it is used either in dissipative applications, such as spark plug tips or in medical implants which are not recovered at the end of life (European Commission, 2017). In spent electrodes, much of the ruthenium and iridium is dissipated during use, so only a small proportion of the original metal can be recovered (Johnson Matthey, 2019a). The global average end-of-life functional recycling rate is estimated to range from 20% to 30%, the fraction of secondary (scrap) metal in the total input to metal production to range between 15% and 20% (recycled content), and the share of old scrap in the total scrap flow (old scrap ratio) to be above 80% (UNEP, 2011; Hagelüken, 2014). Based on these data, and published by (Mathieux *et al.*, 2017), the estimated end-of-life recycling input rate (EoL-RIR) used in the assessment is 14%.

Table 124 provides an overview of the recycling rates by end-use sectors.

**Table 124: Global end-of-life recycling rates (%) for iridium by end-use sector. (Hagelüken, 2014; UNEP, 2011)**

Average EoL recycling rate	Vehicles <sup>1</sup>	Electronics	Industrial applications <sup>2</sup>	Dental	Other <sup>3</sup>	Jewellery and coins
20-30	0	0	40-50	not applicable	5-10	not applicable

<sup>1</sup> Autocatalysts, spark plugs, excluding car electronics  
<sup>2</sup> Including process catalysts/electrochemical, glass  
<sup>3</sup> Including decorative, medical, sensors, crucibles

In addition to recycling from end-of-life products, refineries also process iridium-bearing manufacturing wastes (new scrap) (European Commission, 2017).

#### *Supply of palladium from secondary materials*

The high value of palladium makes it attractive for recycling and sophisticated technology has been developed that permits highly effective recovery from a variety of waste streams, notably autocatalysts and waste electrical and electronic equipment (WEEE). As discussed in the PGM factsheet, recycling makes a significant and growing contribution to global PGM supply, contributing to the market balance of scarce natural resources.

It is believed to be significant international trade in palladium-bearing waste and scrap, but Eurostat data are not available to ascertain the volumes involved (European Commission, 2017).

The secondary supply of palladium from EOL products complements substantially the primary (mine) supply and balances partially the market deficit since 2012. According to Johnson Matthey data, in 2018 palladium recovered from end-of-life products reached an all-time high record accounting for 31% (excluding closed-loop recycling) of the global palladium supply by volume. By far the majority of the recycling volumes for palladium come from the recycling of spent automotive catalysts, ranging between 21% and 26% of the worldwide palladium supply during the last five years (2014-2018). Palladium's recovery from waste electrical and electronic equipment also contributes to global supply accounting for about 5% of the total supply. In 2018, supply from the recycling of autocatalysts represented 84% of the total quantity recovered from EOL products, with electronics (15%) and old jewellery (1%) making up the remainder.

The end-of-life recycling rate of the PGM varies considerably by country and by application (European Commission, 2017). An overview of the recycling rates by end-use sectors is provided in Table 125.

**Table 125: Global end-of-life recycling rates (%) for palladium by end-use sector (Hagelüken, 2014; UNEP, 2011)**

Average EOL recycling rate <sup>1</sup>	Vehicles <sup>2</sup>	Electronics	Industrial Applications <sup>3</sup>	Dental	Other <sup>4</sup>	Jewellery and coins <sup>4</sup>
60-70	50-55	5-10	80-90	15-20	15-20	90-100
<sup>1</sup> Excluding jewellery and coins <sup>2</sup> Autocatalysts, spark plugs, excluding car electronics <sup>3</sup> Including process catalysts/electrochemical, glass <sup>4</sup> Including decorative, medical, sensors, crucibles <sup>5</sup> Including medals and silverware						

Different estimations exist for the recycling indicators of palladium. (UNEP, 2011) and (Hagelüken, 2014) reported that the global average end-of-life functional recycling rate ranges from 60% to 70%, the fraction of secondary (scrap) metal in the total input to metal production is 50% (recycled content), and the share of old scrap in the total scrap flow (old scrap ratio) to be above 80%. According to statistics published yearly by Johnson Matthey, in the period 2014-2018, the proportion of total palladium global supply covered by recycling ranges from 27% to 31% (Johnson Matthey, 2019); these data refer to open-loop recycling from post-consumer scrap. According to data collected in the MSA study carried out by (BIO Intelligence Service, 2015a), the end-of-life functional recycling rate in the EU in 2012 was 47%, and the end-of-life recycling input rate (EoL-RIR) 9%.

The EoL-RIR used in the criticality assessment was 28%, as it is derived from background data published by (Johnson Matthey, 2019) and averaged over the period 2012-2016.

Besides open-loop recycling from end-of-life products, palladium is also recovered in closed-loop industrial processes.

In addition to recovery from end-of-life products, palladium is also recovered from a range of intermediate products and wastes from smelting, refining and manufacturing processes.

#### *Supply of platinum from secondary materials*

The high value of platinum, combined with its relative scarcity, makes it attractive for recycling. Sophisticated technology has been developed that permits highly effective recovery of platinum from a variety of waste streams, mainly autocatalysts and old jewellery. As discussed in the PGM factsheet, recycling makes a significant and growing contribution to global platinum supply, contributing to the market balance of scarce natural resources.

The secondary production of platinum contributes substantially to the global market supply, offsetting partially the weaker mine supply after 2011 and the market deficit in 2012-2016. The majority of the recycling volumes of platinum originates from spent automotive catalysts and jewellery. According to Johnson Matthey data, in 2018 the global supply of platinum from secondary sources accounted for the 26% of the total primary and secondary supply (excluding closed-loop recycling), of which 63% came from autocatalysts, and old jewellery (35%) and electronics (2%) made up the remainder. In the last five years (2014-2018), the share of the world platinum supply covered from the recycling of autocatalysts ranged from 14% to 18%, from old jewellery from 7% to 11%, while waste electrical and electronic equipment recycling covered 0.4% of the worldwide supply.

The end-of-life recycling rate of the PGM varies considerably by country and by application (European Commission, 2017). An overview of the recycling rates by end-use sectors is provided in Table 126.

**Table 126: Global end-of-life recycling rates (%) for platinum by end-use sector (Hagelüken, 2014) (UNEP, 2011)**

Average EoL recycling rate <sup>1</sup>	Vehicles <sup>2</sup>	Electronics	Industrial Applications <sup>3</sup>	Dental	Other <sup>4</sup>	Jewellery and coins <sup>5</sup>
60-70	50-55	0-5	80-90	15-20	10-20	90-100
<sup>1</sup> Excluding jewellery and coins <sup>2</sup> Autocatalysts, spark plugs, excluding car electronics <sup>3</sup> Including process catalysts/electrochemical, glass <sup>4</sup> Including decorative, medical, sensors, crucibles <sup>5</sup> Including medals and silverware						

Several estimations are available for the recycling indicators of platinum. It is reported by (UNEP, 2011) and (Hagelüken, 2014) that the global average end-of-life functional recycling rate ranges from 60% to 70% (see Table 126), the fraction of secondary (scrap) metal in the total input to metal production is 50% (recycled content), and the share of old scrap in the overall scrap flow (old scrap ratio) to be above 80%. According to statistics published yearly by Johnson Matthey, in the period 2014-2018, the contribution of recycling to global platinum supply ranges from 22% to 29% (Johnson Matthey, 2019b); these data refer to open-loop recycling from post-consumer scrap. According to data provided by (BIO Intelligence Service, 2015a), the end-of-life functional recycling rate in the EU was 54% in 2012, and the end-of-life recycling input rate 11%.

The EOL-RIR used in the criticality assessment was 25%, as it is derived from background data published by (Johnson Matthey, 2019b) and averaged over the period 2012-2016.

In addition to open-loop recovery from end-of-life products, platinum is also recovered in closed-loop industrial processes, e.g. in glass manufacturing where old platinum equipment is recycled and turned into new tooling (WPIC, 2019).

Along with end-of-life products, platinum is also recovered from a range of intermediate products and wastes from smelting, refining and manufacturing processes (European Commission, 2017).

#### *Supply of rhodium from secondary materials*

As discussed in the PGM Factsheet recycling makes a significant and growing contribution to global PGM supply, contributing to the market balance of scarce natural resources. The high value of rhodium makes it attractive for recycling. Rhodium is mainly recycled from

spent automotive catalysts for which sophisticated technologies are well established for rhodium recovery.

The recycling of spent autocatalysts makes a vital contribution to the rhodium market balance and security of supply. Recycling from other end-of-life products is negligible (Johnson Matthey, 2018). According to Johnson Matthey data (Johnson Matthey, 2019a), rhodium recovered from autocatalysts accounted for 31% of global supply and 33% of global gross demand in 2018, reflecting a higher contribution of autocatalysts recycling to market balance in comparison with palladium and platinum. The secondary supply of rhodium depends on several factors such as the overall number of the collected end-of-life vehicles and the availability of scrap containing rhodium, which varies by region as car markets and consumer preferences are different. Also, the rhodium loadings in catalysts at the time of their manufacture have an impact. For instance, the increase in rhodium usage in palladium-rhodium three-way catalysts that occurred during the early 2000s with substantially higher average rhodium loadings, and the rhodium thrifting in gasoline catalysts because of the 2007-2008 price spike (Johnson Matthey, 2018; Johnson Matthey, 2017; Johnson Matthey, 2016).

Different estimates are available for the recycling indicators of rhodium. (UNEP, 2011) and (Hagelüken, 2014) reported that the global average end-of-life functional recycling rate ranges from 50% to 60% (see Table 127), the fraction of secondary (scrap) metal in the total input to metal production is 40% (recycled content), and the share of old scrap in the overall scrap flow (old scrap ratio) to be above 80%. According to statistics published annually by Johnson Matthey, recycling (open-loop recycling from post-consumer scrap) contributed between 27% and 31% of the global supply (primary+secondary) of rhodium in the last five years (2014-2018) (Johnson Matthey, 2019a). On the other hand, according to data provided by the MSA study of rhodium (BIO Intelligence Service, 2015a), the end-of-life recycling rate in the EU in 2012 was 62%, and the end-of-life recycling input rate only 9%. In the criticality assessment, the value of 28% was used as the EoL-RIR (average of years 2012 to 2016) derived from background data published by (Johnson Matthey, 2019a).

An overview of the recycling rates by end-use sectors is provided in Table 127.

**Table 127: Global end-of-life recycling rates for rhodium by end-use sector (UNEP, 2011; Hagelüken, 2014)**

Average EOL recycling rate <sup>1</sup>	Vehicles <sup>2</sup>	Electronics	Industrial Applications <sup>3</sup>	Dental	Other <sup>4</sup>	Jewellery and coins <sup>5</sup>
50-60	45-50	5-10	80-90	Not applicable	30-50	40-50
<sup>1</sup> Excluding jewellery and coins <sup>2</sup> Autocatalysts, spark plugs, excluding car electronics <sup>3</sup> Including process catalysts/electrochemical, glass <sup>4</sup> Including decorative, medical, sensors, crucibles <sup>5</sup> Including medals and silverware						

In addition to recycling from end-of-life products, rhodium is also recovered from a range of intermediate products and wastes from smelting, refining and manufacturing processes (European Commission, 2017).

#### *Supply of ruthenium from secondary materials*

Recycling makes a significant and growing contribution to global PGM supply. The PGM supply from secondary materials is also discussed in the PGM factsheet.

Ruthenium is mainly recycled from process catalysts. A small contribution to ruthenium's recycling comes from manufacturing wastes and residues such as spent targets, physical vapour deposition (PVD) shield scrap, machining parts and turnings, as well as ruthenium-containing chemicals, solutions, and other chemical scraps (Umicore, 2019c). The very small amount of ruthenium in computer hard disk drives does not have sufficient value to ensure the economic viability of recycling (UNEP, 2011). In spent electrodes, much of the ruthenium and iridium is dissipated during use, so only a small proportion of the original metal can be recovered (Johnson Matthey, 2019a). Closed-loop recycling can achieve very high levels of ruthenium recovery. In open-loop recycling of consumer products, the rate achieved is generally much lower (European Commission, 2017).

Ruthenium differs from the other platinum-group metals because of its low price and complex chemistry. Ruthenium's price has been too low in the five-year period from 2013 to 2017 to allow the recovery of metal from spent process catalysts, as the refining process was uneconomic, especially for catalysts with a low ruthenium content or where process losses are high. However, the price gains in late 2017 have made recycling more cost-effective and stimulated the recovery of ruthenium from spent process catalyst, which were stockpiled in anticipation of higher prices (Johnson Matthey, 2019a). Nevertheless, much of the ruthenium is lost from the electrodes during use, so only a small proportion of the original metal can be recovered (Johnson Matthey, 2018).

According to (UNEP, 2011) and (Hagelüken, 2014), the global average end-of-life functional recycling rate (EoL-RR) for ruthenium was estimated to range from 5% to 15%, the fraction of secondary (scrap) metal in the total input to metal production to range between 50% and 60% (recycled content), and the share of old scrap in the total scrap flow (old scrap ratio) to be less than 20%. The high recycled content for ruthenium is due to the high availability of new scrap (UNEP, 2011). The end-of-life recycling input rate (EoL-RIR) used in the assessment is estimated to 11% as it is approximated from the above-estimated recycling data and presented by (Mathieux *et al.*, 2017).

(UNEP, 2011) and (Hagelüken, 2014) also provide an overview of the recycling rates by end-use sectors (see Table 128). The global end-of-life recycling rate of ruthenium in electronics and other uses is estimated less than 5%, while in industrial applications a rate of 40-50% is more typical.

**Table 128: Global end-of-life recycling rates (%) for ruthenium by end-use sector. (Hagelüken, 2014; UNEP, 2011)**

Average EoL recycling rate	Vehicles	Electronics	Industrial applications <sup>1</sup>	Dental	Other <sup>2</sup>	Jewellery and coins
5-15	not applicable	0-5	40-50	not applicable	0-5	not applicable
<sup>1</sup> Including process catalysts/electrochemical, glass <sup>2</sup> Including decorative, medical, sensors, crucibles						

## 19.8 Other considerations

### 19.8.1 Environmental and health and safety issues

PGM mining is a capital, energy and labour-intensive process. The International Platinum Group Metals Association (IPA) carried out in 2013 the first-ever industry-wide Life Cycle Assessment (LCA) study. The study quantifies the environmental impacts of both primary and secondary production of PGMs (platinum, palladium and rhodium) for a variety of categories, as well as the fabrication of catalytic converters using PGM and the use of these autocatalysts in a EURO 5 diesel and gasoline vehicle. The Life Cycle Inventory (LCI) dataset is based on data collected from industry, having 2010 as the reference year. The study covers all the main technologies for the production of PGM “from cradle to gate” and is highly representative of the industry. The key findings of the study are (Bossi and Gediga, 2017, IPA, 2015c):

- Power consumption during mining and ore beneficiation is the major environmental impact (72%) of the production of PGM due to the low ore grade, high electricity demand in the mines and concentrators, difficult mining conditions and hard coal dominance in the South African power grid mix. A further 27% of the impacts come from smelting and refining of PGMs;
- Only 1% of impacts are attributed to recycling. The much lower impact of secondary production is due to various reasons, including the enormous difference in the concentration of PGMs between primary and secondary sources;
- The benefits from the use of PGM-based automotive catalysts offset the impacts of PGM production. A reduction of emissions of pollutants, including CO, HC, NO<sub>x</sub> and PM, of up to 97% is achieved, which corresponds to over 1.3 tonnes of avoided emissions in one EURO 5 gasoline plus one EURO 5 diesel vehicle in use over 160,000 kilometres each.

The summary results are presented in Table 129.

**Table 129: Summary results of the Life Cycle Impact Assessment for the average production of 1 gram of PGM (IPA, 2015c)**

	<b>Platinum</b>	<b>Palladium</b>	<b>Rhodium</b>
<b>Global Warming potential (kg CO<sub>2</sub>-eq/g)</b>	33	25	30
<b>Primary energy demand (MJ/g)</b>	387	304	346

The mining industry in South Africa has made significant strides in improving safety in the last years. The overall number of fatalities declined by 88% from 1993 to 2016. In 2018, the platinum sector had a 59% decrease in the number of fatalities, from 29 in 2017 to 12 in 2018, but a 10% increase in the number of injuries (from 1,048 in 2017 to 1,154 in 2018). For a proper assessment, longer time series are required, given the anecdotal character of these accidents. The mining sector of South Africa has set itself the goal of zero-harm by December 2020 (Minerals Council of South Africa, 2019b, Minerals Council of South Africa, 2019c).

EU occupational safety and health (OSH) requirements exist to protect workers' health and safety. Employers need to identify which hazardous substances they use at the workplace, carry out a risk assessment and introduce appropriate, proportionate and effective risk management measures to eliminate or control exposure, to consult with the



workers who should receive training and, as appropriate, health surveillance<sup>210</sup>. At EU level, occupational exposure limit values<sup>211</sup> (OELs) are set for platinum to prevent occupational diseases or other adverse effects in workers exposed to platinum in the workplace. Workers' and employers organisations should be kept informed by member states about the indicative occupational exposure limit values<sup>212</sup> (IOELVs) (Skowroń 2017), which is set for platinum at Community level<sup>213</sup> by Directive 91/322/EEC: 1 mg/m<sup>3</sup> (measured or calculated in relation to a reference period of eight hours).

### 19.8.2 Contribution to low-carbon technologies

The contribution of PGMs to low-carbon technologies is discussed in this section, with a focus on palladium and platinum. In the following, particular contributions of iridium, rhodium and ruthenium are provided.

Fuel cells that operate at low temperatures need catalysts to accelerate electrochemical processes, and the usual choice of catalyst is platinum. Platinum and other PGM (ruthenium and iridium) are used in fuel cells for the same reasons as they are in the automotive and chemical industries; they are excellent catalysts, and they are robust under a fuel cell's harsh operating conditions (Heraeus, 2019).

High-temperature fuel cells do not generally require platinum catalysts. Polymer electrolyte membrane fuel cells (PEMFC) operate at low temperatures and, therefore, require platinum as a catalyst on both the cathode and the anode. The PGM-containing PEMFC is well-suited for the production of hydrogen and powering vehicles. Other fuel-cell technologies requiring platinum are direct methanol fuel cells (DMFC), and phosphoric acid fuel cells (PAFC) (Moss *et al.*, 2013). In PEM-based electrolyzers, platinum catalysts typically contain also ruthenium and iridium (Heraeus, 2019) (Angerer *et al.*, 2016). Ruthenium is also often included in the anode of DMFC operating at low temperature with catalysts made of platinum (Moss *et al.*, 2013).

Fuel cell electric vehicles (FCEVs) are expected to play an important role in the transition to a net-zero carbon transport sector, in particular in long-distance transport, e.g. for long-haul heavy goods vehicles and coaches, provided that the necessary hydrogen refuelling station infrastructure is deployed. To avoid generating carbon at the point of use, fuel cells must be fuelled with hydrogen which can be produced in various ways from a range of sources. Overall carbon emissions are zero or close-to-zero if hydrogen is produced from carbon-neutral energy, by using water electrolysis or natural gas with carbon capture and storage (CCS) (European Commission, 2018). For water electrolysis in particular, which is the reverse of a fuel cell, using renewable electricity avoids carbon emissions during hydrogen generation. This hydrogen is then a form of renewable energy storage and can be used to generate power again when required, or for heating, transportation, and industrial applications. Stationary fuel cells can be used at various scales to generate heat and power, whether within homes or for commercial operations, or even at grid-scale (IPA Industrial expert, 2019).

Various technologies to store, transport and purify hydrogen also use PGM. For example, liquid organic hydrogen carriers (LOHC) are alternately hydrogenated and dehydrogenated to store and release hydrogen. Depending on the specific technology and carrier molecule,

---

<sup>210</sup> <https://ec.europa.eu/social/main.jsp?catId=148>

<sup>211</sup> "OEL means the limit of the time-weighted average of the concentration of a chemical agent in the air within the breathing zone of a worker in relation to a specified reference period" (Skowroń 2017)

<sup>212</sup> as set out by Council Directive 98/24/EC

<sup>213</sup> IOELVs from Directive 91/322/EEC, which was based on an earlier legal framework (Directive 80/1107/EEC), are being scientifically reviewed, as foreseen in art. 3 of the abovementioned Directive 98/24/EC.

platinum catalysts may be used for these processes (Auer et al., 2019). In another example, palladium-based membranes can be used to separate and purify hydrogen from a hydrogen-containing gas mixture, because palladium has the unique property of allowing the preferential permeation of hydrogen (Burkhanov et al., 2011).

Platinum and rhodium alloys are employed in the manufacture of glass-making equipment for the production of fibreglass, which is used to build wind turbines for renewable energy generation, and in automotive lightweight to improve fuel efficiency (IPA Industrial expert, 2019).

#### **Contribution to low-carbon technologies by iridium**

Iridium is an effective catalyst in fuel cells and hydrogen technologies involving polymer electrolyte membrane (PEM) electrolyzers, where it is used in combination with platinum (Angerer et al., 2016; Heraeus, 2019). The generated hydrogen may be used to power fuel cell electric vehicles (FCEV). Iridium is also employed in organic light-emitting diodes (OLEDs), an alternative low energy lighting technologies to the commonly used LEDs.

#### **Contribution to low-carbon technologies by rhodium**

A contribution of rhodium can be considered the production of fibreglass for wind turbines and automotive lightweight, as it is used in platinum alloys for glass-making equipment.

#### **Contribution to low-carbon technologies by ruthenium**

Ruthenium is a material employed by PEM fuel cell (PEMFC) technology for both transport (fuel cell electric vehicles), and stationary applications for hydrogen generation and storage. Ruthenium is used in PEMFC to protect platinum catalysts from poisoning by trace carbon monoxide in the hydrogen fuel (Heraeus, 2019). Finally, the use of ruthenium in alloys for aircraft turbine blades can improve strength, durability and resistance to creep, thus allowing the engines to operate at higher temperatures while burning fuel more efficiently. Ruthenium has a remarkable effect on titanium's corrosion resistance which is improved a hundred times by the addition of just 0.1% of ruthenium (IPA, 2019).

### **19.8.3 Socio-economic issues**

South Africa, the top platinum, rhodium, iridium and ruthenium supplier in the world, has a low governance level for the "political stability and absence of violence/terrorism" component of governance, while the average of the six worldwide governance indicators (WGI) is on a medium level (World Bank, 2018).

Concerning the mining sector, platinum group metals mining is an integral part of the South Africa economy (Baxter, 2019). In 2018 the PGM industry employed directly 167,000 people (Minerals Council of South Africa, 2019a), though, down from 191,000 people in 2013 (IPA, 2015b) and over 200,000 in 2006 (Baxter, 2019). According to the International Platinum Group Metals Association (IPA) companies provide staff with training, permanent housing, health monitoring and create opportunities for local businesses (IPA, 2015b), while employers in the PGM sector enjoy growing, and higher salaries in comparison to other sectors (IPA Industrial expert, 2019). However, unsafe working conditions and long strikes in the main PGM mining companies are also documented (Buratovic et al., 2017). In 2012, following a wildcat strike and violent disputes at the Lonmin mine in Marikana, 46 people, mainly employees, died in the event that became known as "the Marikana tragedy" (Chinguno, 2013)(Cairncross and Kisting, 2016). In 2014, due to major strike operations at western Bushveld owned by Anglo American, Impala Platinum and Lonmin stopped for six months (Johnson Matthey, 2019a); the 2014 strike was a major contributor to the jobs losses that followed (IPA Industrial expert, 2019).

Currently, the PGM industry in South Africa is facing challenges due to domestic labour strife, flat new-mine supply and weaker demand, the increased growth of recycling, declining productivity and rapidly escalating costs (Baxter, 2019). According to the Minerals Council of South Africa, at the end of 2018, more than 65% of PGM operations, representing 52% of PGM production, were marginal or loss-making at prevailing prices, putting in danger around 90,000 jobs. Electricity costs have increased by more than 500% in the period 2008 to 2018, and a further increase of about 30% in production costs is anticipated up to 2021 due to electricity tariff increases (IPA Industrial expert, 2019). After years of underinvestment, it is suggested that significant capital investment is needed to secure jobs (IPA Industrial expert, 2019).

The governance of Russia, the leading global producer of palladium, has been assessed as low, i.e. for the governance components "political stability and absence of violence/terrorism", "rule of law" and "control of corruption" it ranks between the 10<sup>th</sup> and the 25<sup>th</sup> percentile. In the component "voice and accountability" its ranking dropped from the 43<sup>rd</sup> percentile in 1996 to the 19<sup>th</sup> in 2017 (World Bank, 2018).

The social sustainability of the mining industry in Russia is poorly investigated. Some studies focus on the impact of mining on local communities, especially in Northern areas and in the Arctic. In this context, mining is seen both as an opportunity for employment and prosperity and as a thread for what concerns environmental impacts and indigenous rights. Despite a large number of mining areas and activities in Russia, company-community conflicts are rare, and the social acceptance of mining in Russia is high (Tiainen, Sairinen and Sidorenko, 2015; Pettersson *et al.*, 2015; Suopajärvi *et al.*, 2016).

Zimbabwe, which accounts for 7% of the global PGM primary supply, has an even more critical situation, as its governance indicators are very low. Also, it is ranked near the bottom of the 2017 Resource Governance Index categorised as having "failing" governance. This means the country has almost no framework in place to ensure that resource extraction benefits society (NRGI, 2017). Similarly, Zimbabwe ranks very low on rankings of corruption perceptions (157 of 180 countries) and state fragility (10 of 178 countries) (Transparency International, 2017; The Fund for Peace, 2019).

## 19.9 Comparison with previous EU assessments

### 19.9.1 Comparison with previous EU assessments on PGMs in general

In the criticality assessments of 2011 and 2014, the PGMs were treated as a single group. Platinum, palladium, and, to a lesser extent, rhodium had the highest impact on the measured criticality of the group because these metals have much greater economic importance than the other PGMs, while more data are available to assess their supply risk. In the current and the 2017 assessment, the criticality of the five PGMs was assessed individually using the revised methodology. These assessments are discussed in the specific PGM factsheets. Osmium was not assessed because of the very small size of its market and the lack of any quantitative data on its supply and demand. The SR and EI score for the group of PGMs were calculated through an arithmetic average of the SR and EI scores of platinum, palladium, iridium, rhodium and ruthenium, respectively.

The results of this review and earlier assessments are shown in Table 130.

**Table 130: Economic importance and supply risk results for PGMs in the assessments of 2011, 2014, 2017, 2020 (European Commission, 2011);(European Commission, 2014); (European Commission, 2017a)**

Assessment	2011		2014		2017		2020	
Indicator	EI	SR	EI	SR	EI	SR	EI	SR
PGM	6.7	3.6	6.6	1.2	5.0	2.5	5.7	2.4

The results are not comparable to the 2011 and 2014 EU criticality assessments due to the revision of the methodology for assessing economic importance and supply risk introduced in 2017. The averaged Supply Risk (SR=2.4) is marginally lower compared to the 2017 assessment. The trend is mainly attributed to the higher EOL-RIR used in the current assessment for platinum and palladium.

The average Economic Importance (EI) indicator (EI=5.7) is higher in the current assessment in comparison to the previous exercise of 2017. The main parameter affecting the result is the increased value-added of NACE 2 sector "C29 - Manufacture of motor vehicles, trailers and semi-trailers", which corresponds to the application of autocatalysts, the most significant application for PGM in Europe.

### 19.9.2 Comparison with previous EU assessments on individual PGMs

#### 19.9.2.1 Comparison with previous EU assessments on iridium

The assessment has been performed using the revised methodology introduced in the 2017 assessment. The supply risk (SR) has been analysed at the extraction stage of the value chain using only the global HHI calculation. The approach applied is the same as the 2017 assessment, even though the stage of the value chain assessed was cited as "processing/refining stage". It is considered more appropriate to classify the stage evaluated as the "mining stage" because the HHI was calculated on the basis of mine production of primary PGM, allocated where the initial mining took place rather than the location of refining (although this coincides to a large degree). The EU HHI does not contribute to the calculation of the Supply Risk due to lack of appropriate trade data from official sources for import flows of primary materials, i.e. PGM-bearing concentrates or mattes.

The processing/refining stage was not assessed in the current exercise because publicly available statistics on refinery production from primary and secondary sources do not exist. In addition, the complexity of trade flows of intermediate iridium-bearing materials

is such that would require an in-depth analysis highly incompatible with a criticality assessment. Finally, it is not possible to determine the actual supply to the EU because the trade data published by official sources do not differentiate between iridium derived from primary and secondary sources.

The results of this review and earlier assessments are shown in Table 131.

**Table 131: Economic importance and supply risk results for iridium in the assessments of 2011, 2014, 2017, 2020 (European Commission, 2011);(European Commission, 2014); (European Commission, 2017)**

Assessment	2011		2014		2017		2020	
Indicator	EI	SR	EI	SR	EI	SR	EI	SR
PGM	6.7	3.6	6.6	1.2	5.0	2.5	5.7	2.4
Iridium <sup>214</sup>	-	-	-	-	4.3	2.8	4.2	3.2

Iridium was not assessed separately in the previous critical raw materials studies of 2011 and 2014 as the PGMs were treated as a single group. The calculated Supply Risk (SR=3.2) is higher than the 2017 assessment due to the increased share of South Africa, the top producing country (92% in the current assessment in comparison to 85% in the 2017 assessment). The results of the Economic Importance indicator appear marginally lower in the current evaluation due to a decreased contribution in the calculation of EI of the NACE 2 sector 'C20 - Manufacture of chemicals and chemical products', which has a higher value-added than the NACE 2 sector 'C26 - Manufacture of computer, electronic and optical products'. It is noted that in the calculation of the EI of iridium in the current assessment, the share of the applications of iridium denoted as 'Other' is large (39%) and it was allocated among the three major identified applications (electronics, electrochemical and chemical) rather than attributing to the 2-digit NACE sector 'C29 - Manufacture of motor vehicles, trailers and semi-trailers', to reflect the use of iridium in spark plugs and vehicle exhaust systems as in the 2017 assessment.

#### 19.9.2.2 Comparison with previous EU assessments on palladium

The assessment has been performed using the revised methodology introduced in the 2017 assessment. The calculation of the Supply Risk (SR) was carried out at the extraction stage of the value chain using only the global HHI calculation. The approach applied is the same as the 2017 assessment, even though the stage of the value chain assessed was cited as "processing/refining stage". It is considered more appropriate to classify the stage assessed as the "mining stage" because the HHI was calculated on the basis of mine production of primary PGM, allocated where the initial mining took place rather than the location of refining (although this coincides to a large degree). The EU HHI does not contribute to the calculation of the Supply Risk due to lack of appropriate trade data from official sources for import flows of primary materials, i.e. PGM-bearing concentrates or mattes.

The processing/refining stage was not assessed in the current exercise as publicly available statistics on refinery production from primary and secondary sources do not exist. Besides, palladium is contained in a variety of complex intermediate products that would require an in-depth analysis which is incompatible with a criticality assessment. Finally, the actual supply to the EU cannot be determined because the trade data published by official sources do not distinguish between platinum metal derived from primary and secondary sources.

<sup>214</sup> In the 2011 and 2014 assessments the PGM were considered as a single group which included iridium. In the 2017 and the current assessment iridium was considered as a single metal.

The results of this review and earlier assessments are shown in Table 132.

**Table 132: Economic importance and supply risk results for palladium in the assessments of 2011, 2014, 2017, 2020 (European Commission, 2011);(European Commission, 2014); (European Commission, 2017)**

Assessment	2011		2014		2017		2020	
Indicator	EI	SR	EI	SR	EI	SR	EI	SR
PGM	6.7	3.6	6.6	1.2	5.0	2.5	5.7	2.4
Palladium <sup>215</sup>	-	-	-	-	5.6	1.7	7.0	1.3

In the previous critical raw materials studies of 2011 and 2014, palladium was not assessed individually as the PGMs were treated as a single group. The calculated Supply Risk (SR=1.3) is lower in the current assessment due to a higher EoL-RIR. In particular, the EoL-RIR value of 28% was used in the criticality assessment as derived from industrial data published by (Johnson Matthey, 2019), while in the previous one the value of 10% was used based on background data from the MSA study of palladium (BIO Intelligence Service, 2015). Also, the concentration of supply from primary sources has been decreased, i.e. the share of Russian Federation fell from 46% in the 2017 exercise to 40% in the current assessment. This is mainly due to the significant effect on supply that sales from Russian state stocks had in the 2017 assessment, having 2010-2014 as the reference period. In particular, sales from Russian state stocks contributed a significant proportion of the total supply of palladium in the period 2010-2011 but faded out later on. The SR indicator for palladium is the lowest among the PGMs as global supply is more balanced in comparison to platinum, rhodium, ruthenium, and iridium.

The result of the Economic Importance (EI) indicator is higher in the current assessment due to a greater share of the most significant application (autocatalysts) for palladium in Europe, i.e. from 76% in the 2017 assessment to 87% in the current criticality evaluation, and a rise of the value-added of the corresponding NACE 2 sector "C29 - Manufacture of motor vehicles, trailers and semi-trailers". The increase in the value-added for NACE 2 sector C29 in terms of the 28 Members States is 14% (in the current assessment the average of value-added for years 2012-2016 was used, in contrast to the previous exercise referring to the year 2013).

### 19.9.2.3 Comparison with previous EU assessments on platinum

The assessment has been performed using the revised methodology introduced in the 2017 assessment. The calculation of the Supply Risk (SR) was carried out at the extraction stage of the value chain using only the global HHI calculation. The approach applied is the same as in the 2017 assessment, even though the stage of the value chain assessed was cited as "processing/refining stage". It is considered more appropriate to classify the stage evaluated as the "mining stage" because the HHI was calculated based on mine production of primary PGM, allocated where the initial mining took place rather than the location of refining (although this coincides to a large degree). The EU HHI does not contribute to the calculation of the Supply Risk due to lack of appropriate trade data from official sources for import flows of primary materials, i.e. PGM-bearing concentrates or mattes.

The processing/refining stage was not assessed in the current exercise as statistical data on refinery production from primary and secondary sources are not available in the public domain. Also, platinum is contained in a variety of complex intermediate products that would require an in-depth analysis which goes beyond the criticality assessment. Finally, the actual supply to the EU cannot be determined because the trade data published by

<sup>215</sup> In the 2011 and 2014 assessments the PGM were considered as a single group which included palladium. In the 2017 and the current assessment palladium was considered as a single metal.

official sources do not discriminate between platinum metal derived from primary and secondary sources.

The results of this review and earlier assessments are shown in Table 133.

**Table 133: Economic importance and supply risk results for platinum in the assessments of 2011, 2014, 2017, 2020 (European Commission, 2011);(European Commission, 2014); (European Commission, 2017)**

Assessment	2011		2014		2017		2020	
	EI	SR	EI	SR	EI	SR	EI	SR
PGM	6.7	3.6	6.6	1.2	5.0	2.5	5.7	2.4
Platinum <sup>216</sup>	-	-	-	-	4.9	2.2	5.9	1.8

In the previous critical raw materials studies of 2011 and 2014, platinum was not assessed as the PGMs were treated as a single group. The calculated Supply Risk (SR=1.8) is lower in the current assessment due to a higher EoL-RIR. In particular, the EoL-RIR value of 25% was used in the assessment as derived from industrial data published by (Johnson Matthey, 2019b), while in the 2017 assessment the value of 11% was used for the EoL-RIR based on background data from the MSA study of platinum (BIO Intelligence Service, 2015). The results of the Economic Importance (EI) indicator are higher in the current assessment due to a greater share of the most important application for platinum in Europe (autocatalysts) and a strong rise of the value-added of the corresponding NACE 2 sector "C29 - Manufacture of motor vehicles, trailers and semi-trailers". The increase in the value-added for NACE 2 sector C29 in terms of the 28 Members States is 14% (in the current assessment the average of value-added for years 2012-2016 was used, while in the previous exercise the value-added for the year 2013).

#### 19.9.2.4 Comparison with previous EU assessments on rhodium

The assessment has been performed using the revised methodology introduced in the 2017 assessment. The supply risk (SR) has been analysed at the extraction stage of the value chain using only the global HHI calculation. The approach applied is the same as for the 2017 assessment, even though the stage of the value chain assessed was cited as "processing/refining stage". It is considered more appropriate to classify the stage assessed as "mining stage" because the HHI was calculated based on mine production of primary PGMs, allocated where the initial mining took place rather than the location of refining (although this coincides to a large degree). The EU HHI does not contribute to the calculation of the Supply Risk due to lack of appropriate trade data from official sources for import flows of primary materials, i.e. PGM-bearing concentrates or mattes.

The processing/refining stage was not assessed in the current exercise because publicly available statistics on refinery production from primary and secondary sources do not exist. Also, the complexity of trade flows of intermediate rhodium-bearing materials is such that would require an in-depth analysis incompatible with a criticality assessment. Finally, the actual supply to the EU cannot be determined because the trade data published by official sources do not differentiate between rhodium derived from primary and secondary sources.

The results of this and earlier assessments are presented in Table 134.

<sup>216</sup> In the 2011 and 2014 assessments the PGM were considered as a single group which included platinum. In the 2017 and the current assessment platinum was considered as a single metal.

**Table 134: Economic importance and supply risk results for rhodium in the assessments of 2011, 2014, 2017, 2020 (European Commission, 2011);(European Commission, 2014); (European Commission, 2017)**

Assessment	2011		2014		2017		2020	
Indicator	EI	SR	EI	SR	EI	SR	EI	SR
PGM	6.7	3.6	6.6	1.2	5.0	2.5	5.7	2.4
Rhodium <sup>217</sup>	-	-	-	-	6.6	2.5	7.4	2.1

Rhodium was not assessed separately in the previous critical raw materials studies of 2011 and 2014 as the PGM were treated as a single group, only. The calculated Supply Risk (SR=2.1) is lower than the 2017 assessment due to a higher EoL-RIR used (28% instead of 24%) and a slightly smaller market share of the top producing country (i.e. South Africa). The results of the Economic Importance indicator are higher in the current assessment due to a substantial increase of the value-added of NACE 2 sector "C29 - Manufacture of motor vehicles, trailers and semi-trailers" which represents by far the most important application for rhodium. The relative increase in the value-added for NACE 2 sector C29 in terms of the EU28 Members States is 14% (in the current assessment the average value-added for years 2012-2016 was used, while in the previous exercise the value-added for the year 2013).

#### 19.9.2.5 Comparison with previous EU assessments on ruthenium

The assessment has been performed using the revised methodology introduced in the 2017 assessment. The supply risk (SR) has been analysed at the extraction stage of the value chain using only the global HHI calculation. The approach applied is the same as the 2017 assessment, even though the stage of the value chain assessed was cited as "processing/refining stage". It is considered more appropriate to classify the stage evaluated as "mining stage" because the HHI was calculated on the basis of mine production of primary PGMs, allocated where the initial mining took place rather than the location of refining (although this coincides to a large degree). The EU HHI does not contribute to the calculation of the Supply Risk due to lack of appropriate trade data from official sources for import flows of primary materials, i.e. PGM-bearing concentrates or mattes.

The results of this review and earlier assessments are shown in Table 135.

**Table 135: Economic importance and supply risk results for ruthenium in the assessments of 2011, 2014, 2017, 2020 (European Commission, 2011);(European Commission, 2014); (European Commission, 2017)**

Assessment	2011		2014		2017		2020	
Indicator	EI	SR	EI	SR	EI	SR	EI	SR
PGM	6.7	3.6	6.6	1.2	5.0	2.5	5.7	2.4
Ruthenium <sup>218</sup>	-	-	-	-	3.5	3.4	4.1	3.4

<sup>217</sup> In the 2011 and 2014 assessments the PGM were considered as a single group which included rhodium. In the 2017 and the current assessment rhodium was considered as a single metal.

<sup>218</sup> In the 2011 and 2014 assessments the PGM were considered as a single group which included ruthenium. In the current assessment, ruthenium was considered as a single material



Ruthenium was not assessed individually in the assessments of 2011 and 2014 as the PGM were treated as a single group. The calculated Supply Risk (SR=3.44), rounded to SR=3.4) is unchanged from the 2017 assessment as the shares of the global production have remained the same, the EoL-RIR used in the two assessments is also the same and no other changes occurred that may have an effect according to the methodology for calculating the SR.

The results of the Economic Importance (EI) indicator appear higher in the current assessment in comparison to the 2017 assessment. The increase is due to a greater contribution in the calculation of EI of the NACE 2 sector 'C20 - Manufacture of chemicals and chemical products', which has a higher value-added than the NACE 2 sector 'C26 - Manufacture of computer, electronic and optical products'.

## 19.10 Data sources

---

This section describes the sources used:

- for the PGM factsheet (general and per individual PGM): section 19.10.2
- for the criticality assessments of the individual PGMs: section 19.10.3

In addition, the data availability and quality is assessed quantitatively: section

### 19.10.1 Assessment of the availability and quality of data sources

#### 19.10.1.1 Data sources on iridium

There is very little data publicly available for iridium.

Data are not published for the world mine and refinery production of iridium, neither for its global supply. For years 2012 to 2015, production figures were estimated by taking into account mine production data for the category "Other Platinum Metals" (i.e. excluding Pt and Pd) published by the British Geological Survey (BGS, 2019) in combination with production data for rhodium published by 'World Mining Data' (WMD 2019). Furthermore in order to achieve the breakdown between ruthenium and iridium mine production, it was assumed that the annual worldwide output of osmium is 500 kg as reported by (Girolami, 2012) and that ruthenium's and iridium's production is proportional to the size of their markets; data for ruthenium and iridium demand are published by (Johnson Matthey, 2019a). For the year 2016, unpublished production data provided by Johnson Matthey in (European Commission, 2017) were used.

There is no trade code specific to iridium ores and concentrates. The most relevant CN8 code would be 2616 90 00 "Precious metal ores and concentrates excluding silver". However, this code reports data for several precious metals, and it is, therefore, inappropriate to use in the assessment.

Trade data for iridium metal are not available separately. Data for iridium metal in unwrought or powder form is aggregated with osmium and ruthenium under CN code 7110 41 00. Data were extracted from Eurostat, and iridium and ruthenium flows were disaggregated assuming zero trade flows for osmium and in accordance with the relative size of their markets. The trade data include metal from all sources, both primary and secondary. It is not therefore possible to identify the source of the metal and the relative contributions of primary and secondary materials.

Demand data published by Johnson Matthey was the source for the end uses of iridium. The EoL-RIR used was derived from background data provided by UNEP.

#### 19.10.1.2 Data sources on palladium

Mine production data were sourced from 'World Mining Data' published by the Austrian Ministry for Sustainability and Tourism and the International Organising Committee for the World Mining Congress Austrian Ministry of Science, Technology and Commerce. Data for Chinese primary production were sourced from the British Geological Survey, as were not included in the 'World Mining Data' datasets. Data are not available in the public domain for the global refinery production of palladium.

There is no trade code specific to palladium ores and concentrates. The most relevant CN8 code would be 2616 90 00 "Precious metal ores and concentrates excluding silver". However, this code reports data for several precious metals, and it is, therefore, inappropriate to use in the assessment.

Trade data for palladium in unwrought or in powder form was sourced from Eurostat Comext using the CN code 7110 21 00. The trade data include metal from all sources, both primary and secondary. It is not therefore possible to identify the source of the metal and the relative contributions of primary and secondary materials.

The source for the end uses of palladium was European demand data published by Johnson Matthey. The EoL-RIR was derived from worldwide recycling data published by Johnson Matthey.

#### **19.10.1.3 Data sources on platinum**

Mine production data were sourced from 'World Mining Data' published by the Austrian Ministry for Sustainability and Tourism and the International Organising Committee for the World Mining Congress Austrian Ministry of Science, Technology and Commerce. Data for Chinese primary production were sourced from the British Geological Survey, as were not included in the 'World Mining Data' datasets. Data are not available in the public domain for the global refinery production of platinum.

There is no trade code specific to platinum ores and concentrates. The most relevant CN8 code would be 2616 90 00 "*Precious metal ores and concentrates excluding silver*". However, this code reports data for several precious metals, and it is, therefore, inappropriate to use in the assessment.

Trade data for platinum in unwrought or in powder form was sourced from Eurostat Comext using the CN code 7110 11 00. The trade data include metal from all sources, both primary and secondary. It is not therefore possible to identify the source of the metal and the relative contributions of primary and secondary materials.

The source for the end uses of palladium was European demand data published by Johnson Matthey. The EoL-RIR was derived from worldwide recycling data published by Johnson Matthey.

#### **19.10.1.4 Data sources on rhodium**

Mine production data of rhodium were sourced from 'World Mining Data' published by the Austrian Ministry for Sustainability and Tourism and the International Organising Committee for the World Mining Congress Austrian Ministry of Science, Technology and Commerce. Data are not available in the public domain for the global refinery production of rhodium.

There is no trade code specific to rhodium ores and concentrates. The most relevant CN8 code would be 2616 90 00 "*Precious metal ores and concentrates excluding silver*". However, this code reports data for several precious metals, and it is, therefore, inappropriate to use it in the assessment.

Trade data for rhodium in unwrought or in powder form was sourced from Eurostat Comext. The source for the end uses of rhodium was global demand data published by Johnson Matthey. The EoL-RIR was derived from worldwide recycling data published by Johnson Matthey.

#### **19.10.1.5 Data sources on ruthenium**

There is very little data publicly available for ruthenium.

Data are not available in the public domain for the world mine and refinery production of ruthenium, neither for its global supply. For the period 2012-2015, production figures were estimated by taking into account production data for the category "Other Platinum Metals" (i.e. excluding platinum and palladium) published by the British Geological Survey (BGS, 2019) in combination with production data for rhodium published by 'World Mining Data'

(WMD 2019). Furthermore in order to achieve the breakdown between ruthenium and iridium mine production, it was assumed that the annual worldwide output of osmium is 500 kilograms as reported by (Girolami, 2012) and that ruthenium's and iridium's production is proportional to the size of their markets; data for ruthenium and iridium demand are published by (Johnson Matthey, 2019a). For the year 2016, unpublished production data provided by Johnson Matthey in (European Commission, 2017) were used.

There is no CN8 code specific to ruthenium ores and concentrates. The most relevant CN8 code would be 2616 90 00 "Precious metal ores and concentrates excluding silver". However, this code reports data for several precious metals, and it is, therefore, inappropriate to use in the assessment.

Trade data for ruthenium metal are not available separately. Data for ruthenium metal in unwrought or powder form is aggregated with osmium and ruthenium under CN code 7110 41 00. Data were extracted from Eurostat, and iridium and ruthenium flows were disaggregated assuming zero trade flows for osmium and in accordance with the relative size of their markets. The trade data include metal from all sources, both primary and secondary. It is not therefore possible to identify the source of the metal and the relative contributions of primary and secondary materials.

The end uses of ruthenium were sourced by global demand data published by Johnson Matthey. The EoL-RIR used in the assessment was derived from background data published by UNEP.

### **19.10.2 Data sources used in the factsheet**

Ait Abderrahim, A. and Monnet, A. (2018) Report on major trends affecting future demand for critical raw materials. SCRREEN project D.2.2. Available at: <http://screen.eu/results/>

Angerer, G. et al. (2016) Rohstoffe für die Energieversorgung der Zukunft: Geologie – Märkte – Umwelteinflüsse. München. Available at: <https://www.acatech.de/publikation/rohstoffe-fuer-die-energieversorgung-der-zukunft-geologie-maerkte-umwelteinfluesse/>

Arctic Platinum (2019) Suhanko Arctic Platinum Oy. Available at: <https://suhanko.com/> (Accessed: 21 November 2019).

Auer, F. et al. (2019) 'Boosting the activity of hydrogen release from liquid organic hydrogen carrier systems by sulfur-additives to Pt on alumina catalysts', Catalysis Science & Technology. The Royal Society of Chemistry, 9(13), pp. 3537–3547. doi: 10.1039/C9CY00817A.

Baxter, R. (2019) 'A new strategy for the platinum sector. Minerals Council South Africa'. Available at: <https://www.mineralscouncil.org.za/downloads/send/19-latest/718-a-new-strategy-for-the-platinum-sector>

BGS (2009) 'Minerals profile. Platinum'. British Geological Survey - Natural Environment Research Council, pp. 1–32. Available at: <http://www.bgs.ac.uk/mineralsUK/statistics/mineralProfiles.html>

BGS (2019) World mineral statistics data, British Geological Survey. Available at: <https://www.bgs.ac.uk/mineralsuk/statistics/wms.cfc?method=searchWMS>

BIO Intelligence Service (2015a) Study on Data for a Raw Material System Analysis: Roadmap and Test of the Fully Operational MSA for Raw Materials. Available at: <https://ec.europa.eu/jrc/en/scientific-tool/msa>

BIO Intelligence Service (2015b) 'Study on Data Inventory for a Raw Material System Analysis Meeting Report – Notes of the fourth Expert workshop for PGMs, Magnesium, Natural Graphite, Indium and Germanium.', pp. 1–5.

Blagoeva, D. et al. (2016) Assessment of potential bottlenecks along the materials supply chain for the future deployment of low-carbon energy and transport technologies in the EU. Wind power, photovoltaic and electric vehicles technologies, time frame: 2015-2030. doi: 10.2790/08169.

Boliden (2019a) Boliden 2018 Annual and sustainability Report. Available at: <https://www.boliden.com/investor-relations/reports-and-presentations/annual-reports>

Boliden (2019b) Summary tables of mineral resources and mineral reserves, 31 December 2018. Available at: <https://www.boliden.com/operations/exploration/mineral-reserves-and-mineral-resources> (Accessed: 22 September 2019).

Bossi, T. and Gediga, J. (2017) 'The Environmental Profile of Platinum Group Metals', Johnson Matthey Technology Review, 61(2), pp. 111–121. doi: 10.1595/205651317x694713.

BRGM (2014) Panorama 2012 du marché des platinoïdes. BRGM/RP-63169-FR, BRGM/RP-63169-FR.

BRGM (2017a) Fiches de criticité. Le palladium (Pd). Available at: <http://www.mineralinfo.fr/page/fiches-criticite>

BRGM (2017b) Fiches de criticité. Le platine (Pt). Available at: <http://www.mineralinfo.fr/page/fiches-criticite>

Buchholz P., Wellmer F.W., Bastian D., Liedtke M. (2019) Leaning against the wind: Low price benchmarks for acting anticyclically in the metal markets. Mineral Economics. <https://doi.org/10.1007/s13563-019-00199-y>

Buratovic, E. et al. (2017) Controversial Materials based raw materials.

Burkhanov, G. S. et al. (2011) 'Palladium-based alloy membranes for separation of high purity hydrogen from hydrogen-containing gas mixtures', Platinum Metals Review, 55(1), pp. 3–12. doi: 10.1595/147106711X540346.

Cairncross, E. and Kisting, S. (2016) 'Platinum and gold mining in South Africa: The context of the Marikana massacre', New Solutions, 25(4), pp. 513–534. doi: 10.1177/1048291115622027.

Chinguno, C. (2013) 'Marikana Massacre and Strike Violence Post-Apartheid', Global Labour Journal, 4(2), pp. 160–166. doi: 10.15173/glj.v4i2.1138.

CritCat (2019) Rational design of future catalyst materials, CritCat H2020 project website. Available at: <http://www.critcat.eu/> (Accessed: 5 October 2019).

CRM experts (2019) 'Feedback and comments submitted after the CRM validation workshop'.

Cusano, G. et al. (2017) JRC Science for Policy report. Best Available Techniques (BAT) Reference Document for the main Non-Ferrous Metals Industries. doi: 10.2760/8224.

DERA (2017) 'Chart des Monats, Oktober 2017. Preisparität zwischen Platin und Palladium'. Available at: [https://www.deutsche-rohstoffagentur.de/DERA/DE/Publikationen/Chart\\_des\\_Monats/cdm\\_node.html](https://www.deutsche-rohstoffagentur.de/DERA/DE/Publikationen/Chart_des_Monats/cdm_node.html)

Eurostat (2019a). Comext database. Available at: <http://epp.eurostat.ec.europa.eu/newxtweb/>

Eurostat (2019b). Prodcod database. Statistics on the production of manufactured goods (PRODCOM NACE Rev.2), Prodcod - Statistics by Product. Available at: <https://ec.europa.eu/eurostat/web/prodcod> (Accessed: 14 July 2019).

Eurostat (2019c) Annual detailed enterprise statistics for industry (NACE Rev. 2, B-E). Available at: [https://ec.europa.eu/eurostat/en/web/products-datasets/-/SBS\\_NA\\_IND\\_R2](https://ec.europa.eu/eurostat/en/web/products-datasets/-/SBS_NA_IND_R2) (Accessed: 7 July 2019).

European Commission (2011) Critical raw materials. Available at: [https://ec.europa.eu/growth/sectors/raw-materials/specific-interest/critical\\_en](https://ec.europa.eu/growth/sectors/raw-materials/specific-interest/critical_en) (Accessed: 8 July 2019).

European Commission (2014) Report on critical raw materials for the EU - Critical raw materials profiles. Available at: <https://ec.europa.eu/docsroom/documents/11911/attachments/1/translations/en/renditions/pdf>

European Commission (2017a) Study on the review of the list of critical raw materials. Critical Raw Material Factsheets. European Commission. doi: 10.2873/398823.

European Commission (2017b) Study on the review of the list of critical raw materials. Non-Critical Raw Materials Factsheets. European Commission. doi: 10.2873/876644.

European Commission (2018) In-depth analysis in support of the Commission Communication COM(2018)/773. 'A Clean Planet for all. A European strategic long-term vision for a prosperous, modern, competitive and climate neutral economy'. Available at: [https://ec.europa.eu/clima/sites/clima/files/docs/pages/com\\_2018\\_733\\_analysis\\_in\\_support\\_en\\_0.pdf](https://ec.europa.eu/clima/sites/clima/files/docs/pages/com_2018_733_analysis_in_support_en_0.pdf)

European Commission (2019) Negotiations and agreements. Available at: <http://ec.europa.eu/trade/policy/countries-and-regions/negotiations-and-agreements/> (Accessed: 7 July 2019).

FODD (2017) Fennoscandian Mineral Deposits, Fennoscandian Ore Deposit database. V.2017. Available at: <http://en.gtk.fi/information-services/databases/fodd/index.html> (Accessed: 9 August 2019)

Girolami, G. (2012) 'Osmium weighs in', *Nature Chemistry*, 4(11), p. 954. doi: 10.1038/nchem.1479.

Graedel, T. et al. (2015a) 'On the materials basis of modern society', *Proceedings of the National Academy of Sciences*, 112(20). doi: 10.1073/pnas.1312752110.

Graedel, T. et al. (2015b) 'On the materials basis of modern society. Supporting information file', *Proceedings of the National Academy of Sciences of the United States of America*. National Academy of Sciences, pp. 6295–300. doi: 10.1073/pnas.1312752110.

Gunn, G. (2014) 'Platinum-group metals', in Gunn, G. (ed.) *Critical Metals Handbook*. British Geological Survey, John Wiley & Sons, American Geophysical Union, pp. 284–311.

Hagelüken, C. (2012) 'Recycling the platinum group metals: A European perspective', *Platinum Metals Review*, 56(1), pp. 29–35. doi: 10.1595/147106712X611733.

Hagelüken, C. (2014) 'Recycling of (critical) metals', in Gunn, G. (ed.) *Critical Metals Handbook*. British Geological Survey, John Wiley & Sons, American Geophysical Union, pp. 41–69.

Hagelüken, C. (2019) 'Die Märkte der Katalysatormetalle Platin, Palladium und Rhodium – Teil 1', *Metall - Fachzeitschrift für Metallurgie*, 10/19(October). Available at: <https://www.gdmb.de/en/gdmb-verlag-gmbh/for-readers/metall/contents/2019/>

Heraeus (2019) Heraeus Precious metals. The Platinum Standard 2019. Available at: [https://www.heraeus.com/en/hpm/hpm\\_home/heraeus\\_precious\\_metals.html](https://www.heraeus.com/en/hpm/hpm_home/heraeus_precious_metals.html)

IPA (2012) 25 Prominent and Promising Applications using Platinum Group Metals. Available at: <https://ipa-news.com/index/pgm-applications/>

IPA (2015a) 'PGM Fact Sheets. Autocatalysts and Platinum Group Metals'. International Platinum Group Metals Association. Available at: <https://ipa-news.com/index/platinum-group-metals/pgm-fact-sheets.html?PHPSESSID=fbf597ae219fd0e3294f9614a883e22f>

IPA (2015b) 'PGM Fact Sheets. Socio-Economic Development in the PGM Industry'. International Platinum Group Metals Association, pp. 1–10. Available at: <https://ipa-news.com/index/platinum-group-metals/pgm-fact-sheets.html?PHPSESSID=fbf597ae219fd0e3294f9614a883e22f>

IPA (2015c) 'PGM Fact Sheets. The Life Cycle Assessment of Platinum Group Metals'. International Platinum Group Metals Association, pp. 1–7. Available at: <https://ipa-news.com/index/platinum-group-metals/pgm-fact-sheets.html?PHPSESSID=fbf597ae219fd0e3294f9614a883e22f>

IPA (2015d) 'PGM Fact Sheets. The Primary Production of Platinum Group Metals'. International Platinum Group Metals Association. Available at: <https://ipa-news.com/index/platinum-group-metals/pgm-fact-sheets.html?PHPSESSID=fbf597ae219fd0e3294f9614a883e22f>

IPA (2015e) 'PGM Fact Sheets. The Primary Production of Platinum Group Metals'. International Platinum Group Metals Association - PGM Fact Sheets. Available at: <https://ipa-news.com/index/platinum-group-metals/pgm-fact-sheets.html> (Accessed: 4 October 2019).

IPA (2015f) 'PGM Fact Sheets. The Secondary Production and Recycling of Platinum Group Metals'. International Platinum Group Metals Association, pp. 1–6. Available at: <https://ipa-news.com/index/platinum-group-metals/pgm-fact-sheets.html?PHPSESSID=fbf597ae219fd0e3294f9614a883e22f>

IPA industrial expert (2019) Comments and feedback received after the CRM validation workshop on Forward look: Demand, Supply, and Other Considerations.

Johnson Matthey (2014) Market data tables 2004-2013. Available at: <http://www.platinum.matthey.com/services/market-research/market-data-tables> (Accessed: 8 October 2019).

Johnson Matthey (2015) PGM Market Report. November 2015. November 2015, pp. 1–32. Available at: <http://www.platinum.matthey.com/services/market-research/pgm-market-reports>

Johnson Matthey (2016) PGM Market Report. November 2016. Available at: <http://www.platinum.matthey.com/services/market-research/pgm-market-reports>

Johnson Matthey (2017) PGM Market report. May 2017, Johnson Matthey Technology Review. doi: 10.1595/205651316X692121.

Johnson Matthey (2018) PGM Market Report. May 2018. Available at: <http://www.platinum.matthey.com/services/market-research/pgm-market-reports>

Johnson Matthey (2019a) PGM market report. May 2019. Available at: <http://www.platinum.matthey.com/services/market-research/pgm-market-reports>

Johnson Matthey (2019b) Production - South Africa, Johnson Matthey website. Available at: <http://www.platinum.matthey.com/about-pgm/production/south-africa> (Accessed: 4 October 2019).

Johnson Matthey (2019c) Applications, Johnson Matthey website. Available at: <http://www.platinum.matthey.com/about-pgm/applications> (Accessed: 12 October 2019).

Johnson Matthey (2019d) Price charts. Available at: <http://www.platinum.matthey.com/prices/price-charts#> (Accessed: 22 September 2019).

Jones, R. (2005) 'An overview of Southern African PGM smelting', Nickel and Cobalt 2005: Challenges in Extraction and Production, 44th Annual Conference of Metallurgists, Calgary, Alberta, Canada, (21-24 August), pp. 147-178. Available at: <http://www.mintek.co.za/Pyromet/Files/2005JonesPGMsmelting.pdf>

KGHM (2019) Precious metals., KGHM Corporate Website. Available at: <https://kgm.com/en/our-business/products/precious-metals-0> (Accessed: 4 October 2019).

Lauri, L. et al. (2018) Identification and quantification of primary CRM resources in Europe. SCRREEN project D3.1. Available at: <http://screen.eu/results/>

LBMA (2019) London Bullion Market Association (LBMA). Bullion Market. Available at: <http://www.lbma.org.uk/the-london-bullion-market> (Accessed: 22 September 2019).

LPPM (2019) London Platinum & Palladium Market (LPPM). LBMA Platinum and Palladium price data. Available at: <https://www.lppm.com/data/> (Accessed: 22 September 2019).

Marscheider-Weidemann, F. et al. (2016) Rohstoffe für Zukunftstechnologien 2016 - DERA Rohstoffinformationen 28. Edited by D. R. (DERA) in Der and B. für G. und R. (BGR). Berlin.

Mathieux, F. et al. (2017) Critical raw materials and the circular economy - Background report. EUR 28832 EN, Publications Office of the European Union, Luxembourg. doi: 10.2760/378123.

Merschel, G. and Krämer, D. (2018) DERA Rohstoffinformationen. Hydrometallurgical extraction of platinum and palladium from oxidized PGE ores of the Bushveld Complex, South Africa – short report.

Minerals Council of South Africa (2019a) 'Facts and Figures. 2018 Edition'. Available at: [https://39k5cm1a9u1968hg74aj3x51-wpengine.netdna-ssl.com/wp-content/uploads/2019/07/2018\\_NHPCO\\_Facts\\_Figures.pdf](https://39k5cm1a9u1968hg74aj3x51-wpengine.netdna-ssl.com/wp-content/uploads/2019/07/2018_NHPCO_Facts_Figures.pdf)

Minerals Council of South Africa (2019b) 'Factsheet. Safety in mining', pp. 1-6.

Minerals Council of South Africa (2019c) 'Safety in the mining industry. Performance at a glance', pp. 1-2.

Minerals4EU (2019) European Minerals Yearbook. Available at: [http://minerals4eu.brgm-rec.fr/m4eu-yearbook/theme\\_selection.html](http://minerals4eu.brgm-rec.fr/m4eu-yearbook/theme_selection.html)

Moss, R. L. et al. (2011) Critical Metals in Strategic Energy Technologies, JRC-scientific and strategic reports, European Commission Joint Research Centre Institute for Energy and Transport. doi: 10.2790/35600.

Moss, R. et al. (2013) Critical Metals in the Path towards the Decarbonisation of the EU Energy Sector, JRC82322. doi: 10.2790/46338.



Mudd, G. M., Jowitt, S. M. and Werner, T. T. (2018) 'Global platinum group element resources, reserves and mining – A critical assessment', *Science of The Total Environment*. Elsevier, 622–623, pp. 614–625. doi: 10.1016/J.SCITOTENV.2017.11.350.

Nassar, N. (2015) 'Limitations to elemental substitution as exemplified by the platinum-group metals', *Green Chemistry*, (17), pp. 2226–2235. doi: 10.1039/x0xx00000x.

Ndlovu, J. (2015) 'Anglo American Platinum: Precious Metals Supply. Presentation given at EC International Conference, Exchange of good practices on metal by-products recovery. Technology and policy challenges. Brussels, 12-13 November 2015.', pp. 1–21. Available at: <http://ec.europa.eu/DocsRoom/documents/14045/attachments/1/translations/en/renditions/native>

Nornickel (2018) Annual Report 2017. Available at: <https://ar2017.nornickel.com/#about> (Accessed: 22 September 2019).

NRGI (2017) '2017 Resource Governance Index', p. 28. Available at: <http://www.resourcegovernance.org/countries/africa/tanzania/overview>

OECD (2019) Export Restrictions on Industrial Raw Materials. Available at: [https://gdd.oecd.org/subject.aspx?Subject=ExportRestrictions\\_IndustrialRawMaterials](https://gdd.oecd.org/subject.aspx?Subject=ExportRestrictions_IndustrialRawMaterials) (Accessed: 5 July 2019).

Partial-PGMs (2019) Development of novel, high-performance hybrid TWV/GPF automotive after-treatment systems by rational design: substitution of PGM and Rare Earth materials, Partial-PGMs H2020 project website. Available at: <http://www.partial-pgms.eu/> (Accessed: 6 October 2019).

Pettersson, M. et al. (2015) 'License to Mine: A Comparison of the Scope of the Environmental Assessment in Sweden, Finland and Russia', *Natural Resources*, 06(04), pp. 237–255. doi: 10.4236/nr.2015.64022.

PWC (2019) South Africa Mine in 2019. In transition.

Rudnick, R. L. and Gao, S. (2014) *Composition of the Continental Crust*, Treatise on Geochemistry: Second Edition. Elsevier Ltd. doi: 10.1016/B978-0-08-095975-7.00301-6.

S&P Global (2018a) S&P Global Market Intelligence database. Metals & Mining Properties. Palladium, S&P Global Market Intelligence.

S&P Global (2018b) S&P Global Market Intelligence database. Metals & Mining Properties. Platinum, S&P Global Market Intelligence.

Schmidt, M. (2015) Rohstoffrisikobewertung – Platingruppenmetalle. Platin, Palladium, Rhodium. DERA Rohstoffinformationen 26, DERA Rohstoffinformationen. Berlin. Available at: [https://www.deutsche-rohstoffagentur.de/DERA/DE/Downloads/studie\\_Platin\\_2015.pdf?blob=publicationFile&v=2](https://www.deutsche-rohstoffagentur.de/DERA/DE/Downloads/studie_Platin_2015.pdf?blob=publicationFile&v=2)

Skowroń, J. (2017). Occupational exposure limit values. *OSHWiki*, Available at: [http://oshwiki.eu/index.php?title=Occupational\\_exposure\\_limit\\_values&oldid=247440](http://oshwiki.eu/index.php?title=Occupational_exposure_limit_values&oldid=247440), accessed: 29.01. 2020

Sundqvist Ökvist, L. et al. (2018) Production technologies of critical raw materials from secondary resources. SCRREEN project D.4.2. Available at: <http://screen.eu/results/>

Suopajarvi, L. et al. (2016) 'Social sustainability in northern mining communities: A study of the European North and Northwest Russia', *Resources Policy*. Elsevier Ltd, 47, pp. 61–68. doi: 10.1016/j.resourpol.2015.11.004.

Sverdrup, H. U. and Ragnarsdottir, K. V. (2016) 'A system dynamics model for platinum group metal supply, market price, depletion of extractable amounts, ore grade, recycling and stocks-in-use', *Resources, Conservation and Recycling*. Elsevier B.V., 114, pp. 130–152. doi: 10.1016/j.resconrec.2016.07.011.

Tercero, L. (2019) Report on the future use of critical raw materials. SCRREEN project D.2.3. Available at: <http://screen.eu/results/>

Tercero, L. et al. (2015) Critical Raw Materials Substitution Profiles, CRM \_Innonet. Available at: [http://publica.fraunhofer.de/eprints/urn\\_nbn\\_de\\_0011-n-4455718.pdf](http://publica.fraunhofer.de/eprints/urn_nbn_de_0011-n-4455718.pdf)

Tercero, L. et al. (2018) Critical Raw Material substitution profiles. SCRREEN project D5.1., SCRREEN - D5.1. Available at: <http://screen.eu/wp-content/uploads/2018/05/SCRREEN-D5.1-CRM-profiles.pdf>

The Fund for Peace (2019) Fragile States Index. Available at: <https://fragilestatesindex.org/> (Accessed: 21 October 2019).

Tiainen, H., Sairinen, R. and Sidorenko, O. (2015) 'Governance of Sustainable Mining in Arctic Countries: Finland, Sweden, Greenland & Russia', in *Arctic Yearbook*, pp. 132–157.

Transparency International (2017) Corruption Perceptions Index 2017. Available at: [https://www.transparency.org/news/feature/corruption\\_perceptions\\_index\\_2017](https://www.transparency.org/news/feature/corruption_perceptions_index_2017) (Accessed: 21 October 2019).

Umicore (2019a) Precious metals refining. Metals & Products. Precious Metals, Umicore webpage. Available at: <https://pmr.umicore.com/en/metals-products/precious-metals/> (Accessed: 23 September 2019).

Umicore (2019b) Recyclables, Umicore website. Available at: <https://pmr.umicore.com/en/recyclables/> (Accessed: 11 October 2019).

Umicore (2019c) From Ag to Zn, Umicore website - All the metals used or recycled at Umicore. Available at: <https://www.umicore.com/en/about/elements/> (Accessed: 4 October 2019).

UN Comtrade (2019) International Trade Statistics Database. Available at: <https://comtrade.un.org/> (Accessed: 8 July 2019).

UNEP (2011) Recycling Rates of Metals – A Status Report, A Report of the Working Group on the Global Metal Flows to the International Resource Panel., Group. doi: ISBN 978-92-807-3161-3.

USGS (2019) Mineral Commodity Summaries 2019. U.S Geological Survey. doi: 10.1007/978-3-540-47108-0-4.

Viljoen, M. (2016) 'The Bushveld Complex: Host to the World's Largest Platinum, Chromium and Vanadium Resources. Episodes', *Episodes*, 39(2), pp. 239–268.

WMD (2019) World Mining Data 2019, Reichl, C.; Schatz, M; Zsak, G. Iron and Ferro Alloy Metals, non Ferrous Metals, Precious Metals, Industrial Minerals, Mineral Fuels. Austrian Federal Ministry of Sustainability and Tourism. [online] Available at: [www.en.bmfwf.gv.at/Energy/WorldMiningData/Seiten/default.aspx](http://www.en.bmfwf.gv.at/Energy/WorldMiningData/Seiten/default.aspx)

World Bank (2018) Aggregate Governance Indicators 1996-2017, Worldwide Governance Indicators. Available at: <http://info.worldbank.org/governance/WGI/#home> (Accessed: 7 July 2019).

WPIC (2019) 'Platinum recycling'. World Platinum Investment Council. Available at: <https://www.platinuminvestment.com/about/60-seconds-in-platinum/2019/10/02>

Yang, J. et al. (2018) Production technologies of critical raw materials from primary resources. SCRREEN project D.4.1. Available at: <http://screen.eu/results/>

Zientek, M. et al. (2017) 'Platinum-Group Elements. U.S. Geological Survey Professional Paper 1802-K', in Schulz, K. J. et al. (eds) Critical Mineral Resources of the United States— Economic and Environmental Geology and Prospects for Future Supply. US Geological Survey, pp. N1–N92. Available at: <https://doi.org/10.3133/pp1802>

### **19.10.3 Data sources used in the criticality assessment of the individual PGMs**

BGS (2019) World mineral statistics data, British Geological Survey. Available at: <https://www.bgs.ac.uk/mineralsuk/statistics/wms.cfc?method=searchWMS>

European Commission (2017) *Study on the review of the list of critical raw materials. Critical Raw Material Factsheets*. European Commission. doi: 10.2873/398823.

Eurostat Comext (2019) *Easy Comext database*. Available at: <http://epp.eurostat.ec.europa.eu/newxtweb/>.

Johnson Matthey (2018) *PGM Market Report. May 2018*. Available at: <http://www.platinum.matthey.com/services/market-research/pgm-market-reports>

Johnson Matthey (2019) *PGM Market report. May 2019*. Available at: <http://www.platinum.matthey.com/services/market-research/pgm-market-reports>

UNEP (2011) *Recycling Rates of Metals – A Status Report, A Report of the Working Group on the Global Metal Flows to the International Resource Panel., Group*. doi: ISBN 978-92-807-3161-3.

WMD (2019) World Mining Data 2019, Reichl, C.; Schatz, M; Zsak, G. Iron and Ferro Alloy Metals, non Ferrous Metals, Precious Metals, Industrial Minerals, Mineral Fuels. Austrian Federal Ministry of Sustainability and Tourism. [online] Available at: [www.en.bmwf.gv.at/Energy/WorldMiningData/Seiten/default.aspx](http://www.en.bmwf.gv.at/Energy/WorldMiningData/Seiten/default.aspx)

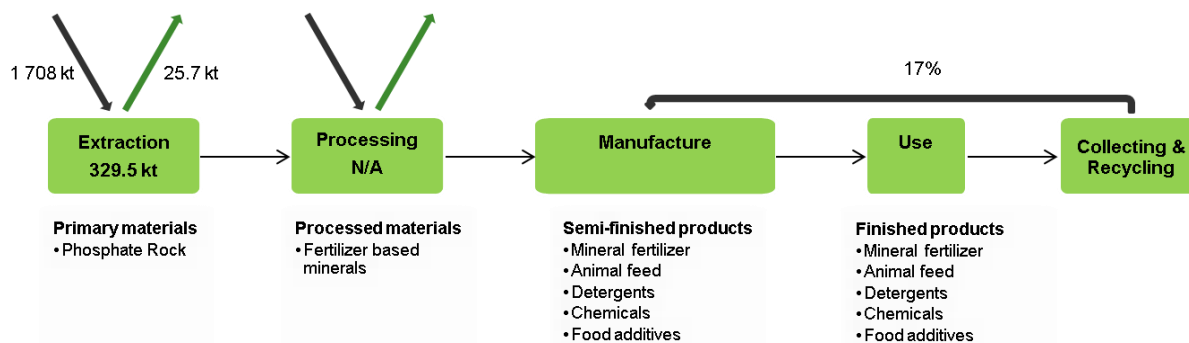
## **19.11 Acknowledgments**

---

This factsheet was prepared by the JRC. The authors would like to thank the Ad Hoc Working Group on Critical Raw Materials, as well as experts participating in SCRREEN workshops for their contribution and feedback, in particular Mr Julian Köhle (IPA), Mr Christian Hagelüken (Umicore), Mr Rupen Raithatha and Ms Alison Cowley (Johnson Matthey), Mr Antoine Monnet (LGI Consulting), and Ms Barbara Forriere (Renault - Nissan - Mitsubishi).

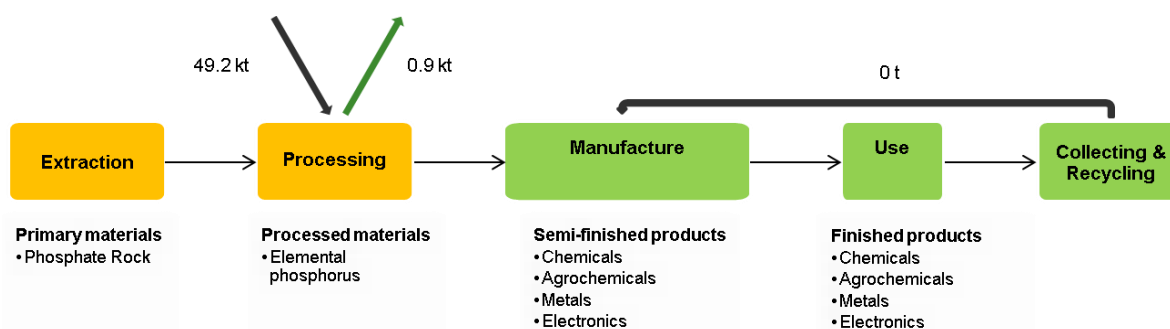
# 20 PHOSPHATE ROCK AND ELEMENTAL PHOSPHORUS

## 20.1 Overview



**Figure 303: Simplified value chain for phosphate rock, data in tonnes of  $P_2O_5$  for the EU, averaged over 2012-2016.**

Phosphate rock is the main anthropogenic source of phosphorus (chemical symbol P) and is in effect an “indicator” of phosphorus in different forms (mineral, organic) used in agriculture and industry (fertiliser chemicals or phosphoric acid, but also organic fertilisers, manures, crop products used as animal feed). Phosphorus is one of the six main building blocks of life (together with oxygen, hydrogen, potassium, nitrogen and carbon) and is vital for all life on planet earth, including plants, animals and humans, and so for the bio based economic processes that take place in the global economy. Phosphate rock refers to rocks containing different phosphate minerals, in particular calcium phosphate as apatite which can be commercially exploited.



**Figure 304: Simplified value chain for elemental phosphorus, data in tonnes of  $P_4$  for the EU, average 2012-2016**

Elemental phosphorus here refers to the specific forms of the element phosphorus (P) in which it is produced as an isolated element ( $P_4$ ) in dedicated electrothermal reducing furnaces (in different forms: white/yellow or red phosphorus). Such isolated elemental phosphorus is generally transformed and transported in the form of chemical vectors such as phosphorus trichloride ( $PCl_3$ , the main precursor for organic phosphorus chemistry) or sulphides, oxides or very pure (electronics grade) phosphoric acid. Elemental phosphorus thus represents only a small part of the total use of “phosphate rock”, most of which is processed to less pure phosphoric acid for production of fertilisers or other inorganic phosphate chemicals.

The orange boxes of the production and processing stages in Figure 304 suggest that activities are not undertaken within the EU for extraction and processing stages. Even if

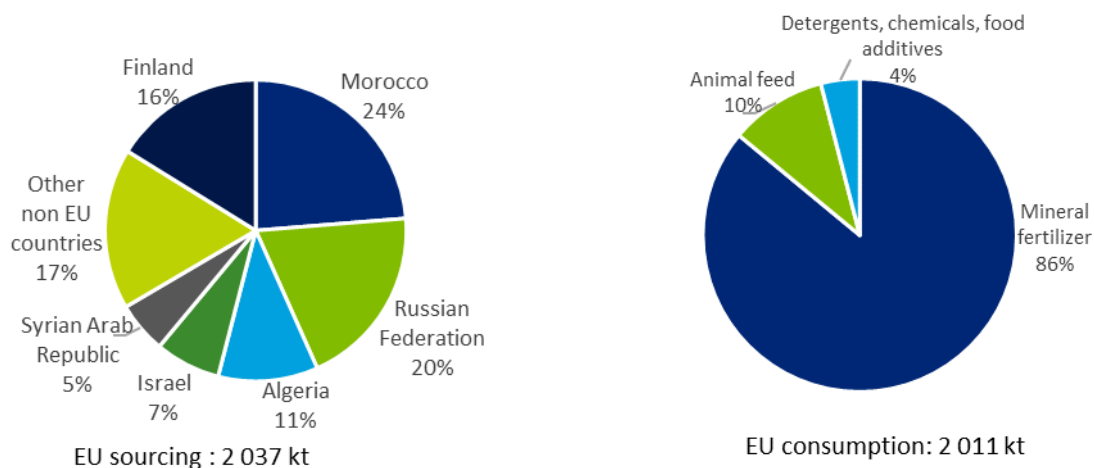
phosphate rock is extracted within the EU the extracted amount is not used to produce elemental phosphorus (e.g. white phosphorus). It is assumed that there is no functional recycling of elemental phosphorus.

Trade flows can be estimated using the following CN8 codes: 25101000 (natural calcium phosphates and natural aluminium calcium phosphates, natural and phosphatic chalk, unground) and 25102000 (natural calcium phosphates and natural aluminium calcium phosphates, natural and phosphatic chalk, ground). For elemental phosphorus the considered code was CN 28047000 (phosphorus).

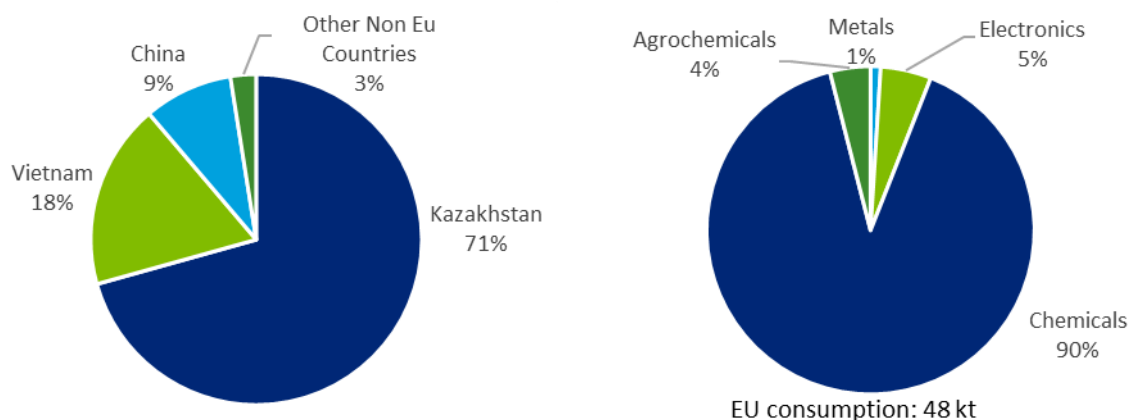
In the period between 2012 and 2016, the global market for phosphate rock was on average 76,719 kt of  $P_2O_5$  per year. Although most phosphate rock resources are located in Morocco, China is the dominant producer. For secondary raw materials there are various sources of phosphorous, such as animal manures, sewage and food waste. For this assessment an EOL-RIR (End-of-Life Recycling Input Rate) of 17% was assumed, it is however recognised that further research is needed to estimate the actual amount of phosphorus that is being replaced by these organic wastes and by manure (ESPP, 2019).

Regarding elemental phosphorus the main producer was China with 87% of the world production in 2016 (IHS, 2017). However, in China the majority of the production is used internally. Additionally, Chinese production has decreased significantly over the last years since 2012 (ESPP, 2019). Kazakhstan is the second biggest producer and the major world supplier. Elemental phosphorus is only produced outside the EU in electrothermal reducing furnaces. The exact world production was not known but should be around 1,200 kt of  $P_4$  per year (averaged over 2012-2016) (IHS, 2017).

The average price of phosphate rock ore (70%) from Morocco between 2014 and 2018 was US\$ 103.76 per tonne (DERA, 2019). In 2019 over 6 months the prices of elemental phosphorus ranged between US\$ 2.1 per kilogram and US\$ 3.7 per kilogram (180 and 450 EUR/kg) (ECHEMI, 2019).



**Figure 305: EU sourcing and end uses of Phosphate Rock, data in tonnes of  $P_2O_5$  (Eurostat, 2019), (ESPP, 2019).**



**Figure 306: EU sourcing and end uses of Elemental Phosphorus, data in tonnes of P<sub>4</sub> (Eurostat, 2019), (ESPP, 2019).**

The EU demand of phosphate rock is on average 2 011 kt of P<sub>2</sub>O<sub>5</sub> per year between 2012 and 2016. EU's import reliance of phosphate rock was around 84% (average 2012-2016), given the input from Finland. Main exporting countries to the EU are Morocco and Russian Federation.

The EU annual consumption of elemental phosphorus was 48.3 kt of P<sub>4</sub> on average between 2012-2016 period. EU's is completely dependent on imports with 71% of EU supply coming from Kazakhstan (Eurostat, 2019).

Phosphorus is a vital part of plant and animal nourishment. Phosphate rock is globally utilised for the fertilisation of food crops. Pure elemental phosphorus, obtained from phosphate rock, is used for the production of chemicals (e.g. flame retardants, oil additives, industrial water treatment, emulsifying agents).

The resources are relatively abundant globally 68,705,000 kt and known reserves are documented and sedimentary phosphate deposits occur on every continent but known reserves are highly concentrated in a few countries, mainly Morocco.

For reserves, Minerals4EU (2019) only reports phosphate rock reserves in Ukraine, with 115,800 kt of apatite ore, and 4,550 kt of P<sub>2</sub>O<sub>5</sub> contained in the apatite ores according to Russian Classification (RUS)A.

For the 2012-2016 period, export taxes were put in place by China, Morocco and Vietnam for the relevant product groups containing natural calcium phosphates. Egypt had introduced an exports prohibition. There is also an export quota imposed by China of 1,000 kt of natural calcium phosphates.

The export taxes are imposed by Kazakhstan and China.

## 20.2 Market analysis, trade and prices

### 20.2.1 Global market analysis and outlook

The estimations in the Table 136 regarding future demand and supply trends are based on (International Fertilizer Association, 2019), (FAO, 2019), and (European Commission, 2017b).

Globally the production of food at current yields is dependent on mined phosphate rock for the production of fertilisers. Therefore, the future market of phosphate rock is in a great extent controlled by changes in supply and demand of fertilisers used in agriculture and strongly connected with the global population growth. According with the International Fertiliser Association (IFA) (International Fertilizer Association, 2019) and Food and Agriculture Organization (FAO, 2019), global demand of fertilisers is expected to increase on average by 1.1% per annum (between 2018 to 2023), with a 1.2% per annum demand increase for phosphorus (in fertilisers). The highest rate of growth in demand is anticipated in Africa (especially Sub-Saharan Africa), followed by Eastern Europe and Central Asia (region), South Asia and Latin America and North America. Demand will remain stable in East Asia and Western and Central Europe and would increase only modestly in Oceania and West Asia.

Estimates reveal that population growth will foster the increase in demand of phosphate rock. However, in developed countries and in an increasing number of emerging economies several secondary sources of phosphorus are already being considered (e.g. animal manure, wastewater and food waste) to reduce the dependence on phosphate rock for fertiliser production. According with SCRREEN estimates, by 2035 the reliance of the agriculture sector on mineral fertilisers (and in turn on phosphate rock) will be very low. In particular if the phosphorus accumulation in soils is taken into account for agriculture (Monnet and Ait Abderrahim, 2018).

On the supply side the production of phosphate rock is expected to increase during the studied periods. More precisely, the IFA projects an increase from 235Mt in 2018 to 255 Mt in 2023 of the global phosphate rock supply (an increase of 8%). Africa would account for 75% of the net increase during this period. Supply and demand are expected to grow modestly in the near term.

Phosphorus is one of the most abundant elements in the planetary crust, although concerns exist regarding supply shortage. Studies predict that phosphate rock reserves will be depleted sometime in the next 100 years (Tercero et al., 2018). In addition, it should be noted that the "20 years" scale is approximately the delay time between planning new phosphate rock mining capacity. Its production coming onto the market, given delays in authorization, funding, machinery investment, transport and processing infrastructure (ESPP, 2019). Most of the phosphate reserves are not developed yet for production. According to SCRREEN, taking into account the current production and demand growth an inelastic supply gap at market may occur in the decade of 2020 to 2030 (Tercero et al., 2018). The use of secondary sources of phosphate may attenuate this situation allowing to extend reserves viable life by 50 years, this taking into account a reference of 2018 (Monnet and Ait Abderrahim, 2018).

The main producing country of Phosphate rock is China (however it is not an important global supplier). Morocco has 71% of the world's reserves.

Regarding elemental phosphorus, the demand has declined during the past 10 to 20 years. Which resulted in a significant capacity decrease in both Europe and North America. In contrast, the production capacity in China has increased rapidly and is now the top producing country with 87% of the annual capacity in 2016. Like China, also Vietnam has increase production capacity in the last 10 years. However, this expansion have slowed down in the last years (IHS, 2017).



**Table 136: Qualitative forecast of supply and demand of Phosphate rock and Phosphorus**

Materials	Criticality of the material in 2020		Demand forecast			Supply forecast		
	Yes	No	5 years	10 years	20 years	5 years	10 years	20 years
Phosphate rock	x		+	+	+	+	+	+
White Phosphorus	x		0	0	-	+	+	0

### 20.2.2EU trade

Overall, the EU is a net importer of phosphate rock, importing over 1,708 kt of P<sub>2</sub>O<sub>5</sub> net per year (average between 2012 to 2016) in the form of natural calcium phosphates and natural aluminium calcium phosphates, natural and phosphatic chalk, unground and ground (Figure 307). Average between 2012 and 2016 exports are lower than 25 kt (Eurostat Comext, 2019)

Morocco was between 2012 and 2016 the largest exporter of phosphate rock into the EU, covering around 28% of all imports. Other major importers include Algeria, Russia and Israel (Figure 307), with shares between 8% and 23%. EU exports are mainly towards Norway; however, these amounts are negligible compared to imports.

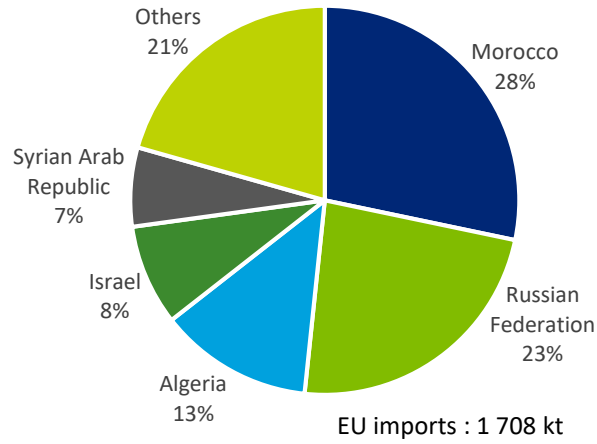
The following CN codes were used for this analysis: 25101000 "natural calcium phosphates and natural aluminium calcium phosphates, natural and phosphatic chalk, unground" and 25102000 "natural calcium phosphates and natural aluminium calcium phosphates, natural and phosphatic chalk, ground". A content of 30% of P<sub>2</sub>O<sub>5</sub> was assumed based on estimates calculated from comparison of (WMD, 2019, BGS, 2019, USGS, 2017).

On average between 2012 and 2016 the EU imports were 49.2 kt of P<sub>4</sub> per year. Kazakhstan was the biggest exporter of elemental phosphorus into the EU, covering around 71% of all imports. Other major importers are China and Vietnam (Figure 309). The code CN 28047000 "phosphorus" was used for this analysis. The exports of P<sub>4</sub> are almost not existent between 2013 and 2016, the low amounts exported <1t are probably due to re-exports, since no production is observed in the EU.

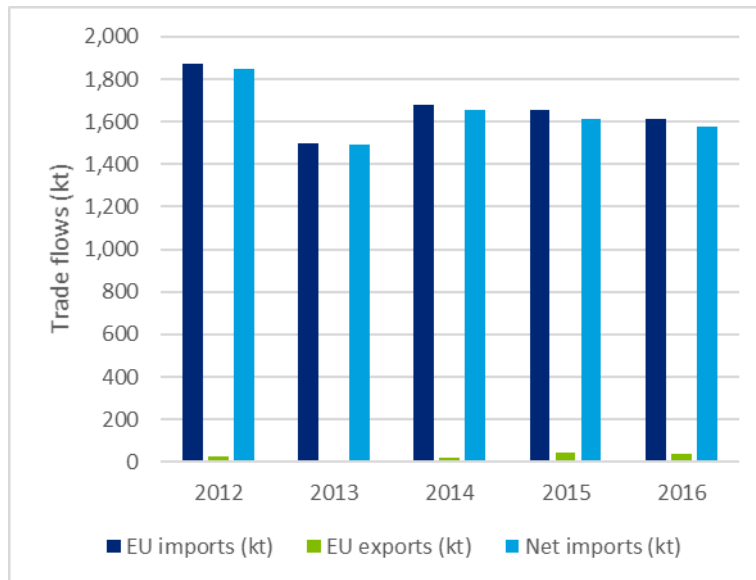
For the 2012-2016 period, export taxes are put in place by China, Morocco and Vietnam for the relevant product groups containing natural calcium phosphates. Egypt had introduced an exports prohibition. There is also an export quota imposed by China of 1,000 kt of natural calcium phosphates (OECD, 2019), (European Commission, 2019).

The export taxes are imposed by Kazakhstan and China restrictions for phosphorus.

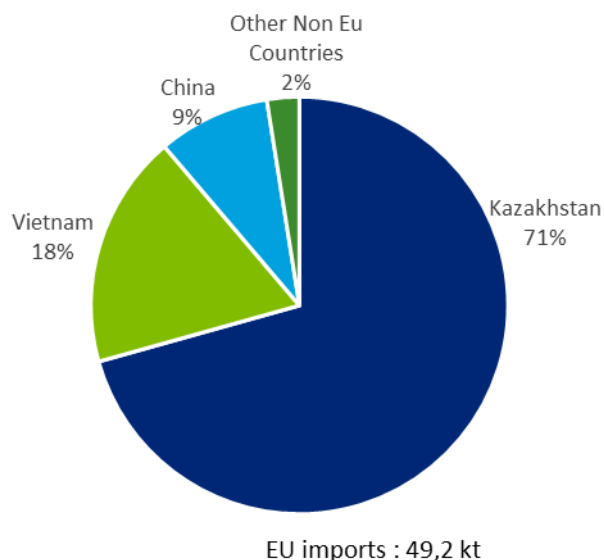
There are free trade agreements with Morocco, Algeria and Israel.



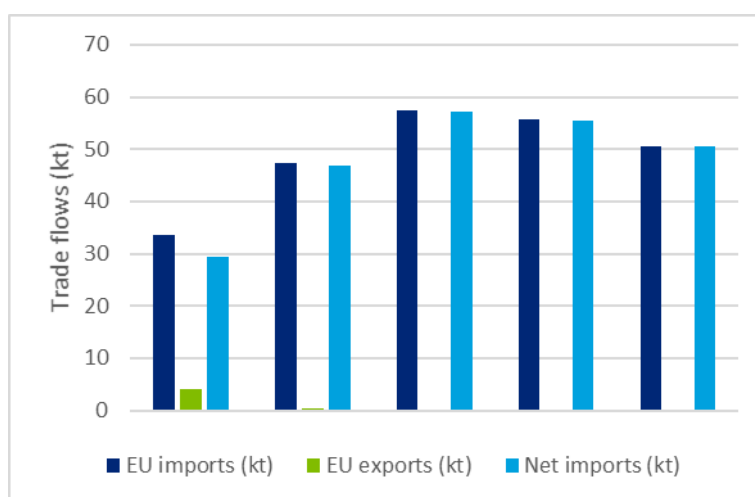
**Figure 307: EU imports of phosphate rock (in P<sub>2</sub>O<sub>5</sub> content), 2012-2016 average (Eurostat, 2019b).**



**Figure 308: EU trade flows for phosphate rock (in P<sub>2</sub>O<sub>5</sub> content), data from (Eurostat, 2019b).**



**Figure 309: EU imports of elemental phosphorus in P<sub>4</sub>, average 2012-2016 (Eurostat, 2019b).**



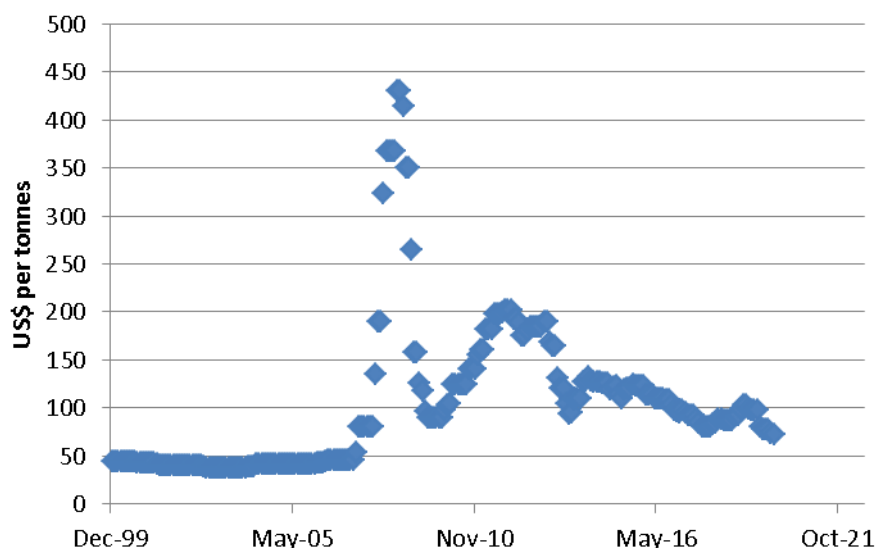
**Figure 310: EU trade flows for elemental phosphorus, in P<sub>4</sub>, data from (Eurostat, 2019b).**

### 20.2.3 Prices and price volatility

The development of prices for phosphate rock is shown in Figure 311. The price spike around 2008 originated from an imbalance between supply and constantly expanding demand over decades, especially in Asia. This imbalance has several causes, such as: 1) lack of investment in mining and the very long delay time between planning new mining capacity and its effective production start; 2) implementation of export tariffs by some countries; 3) political unrest fuelling concerns about supply security (Arab Spring); 4) increased demand for fertilizers to produce biofuels in the United States, Brazil, and Europe; 5) Increased livestock production created still more demand for grain and thus for fertilizers (IFDC, 2010). Demand was particularly strong in China and India, countries with large and growing populations. The price spike also affected other commodities such as potassium. Overall, phosphate rock and fertiliser prices are both tied to global food

prices. The global economic crises caused the prices to fall relatively fast, but prices remain more volatile ever since.

The annual average price of Phosphate rock ore from North Africa (Morocco) between 2014 and 2018 was US\$ 103.75 per tonne (which is a proximally 93.78 EUR/t). The annual average price from October 2018 to September 2019 was US\$ 93.91 per tonne (84.52 EUR/t), which shows a decrease of 9.5% in comparison with the previous 4 years average (DERA and BGR, 2019).



**Figure 311 Global developments in price of phosphate rock (Morocco), 70% BPL (Indexmundi, 2019):**

In 2019 over 6 months the prices of elemental phosphorous ranged between 2.1 and US\$ 3.7 per kilogram (180 and 450 EUR/kg) (ECHEMI, 2019). The average value of exports of elemental phosphorous from the United States between 2015 and 2016 was around US\$ 3.4 per kilogram (Jasinski, 2016).

## 20.3 EU demand

### 20.3.1 EU demand and consumption

The EU annual apparent consumption of phosphate rock was 2,011 kt of P<sub>2</sub>O<sub>5</sub> on average over the 2012-2016 period. The EU consumption of elemental phosphorus is 48.3 kt of P<sub>4</sub>.

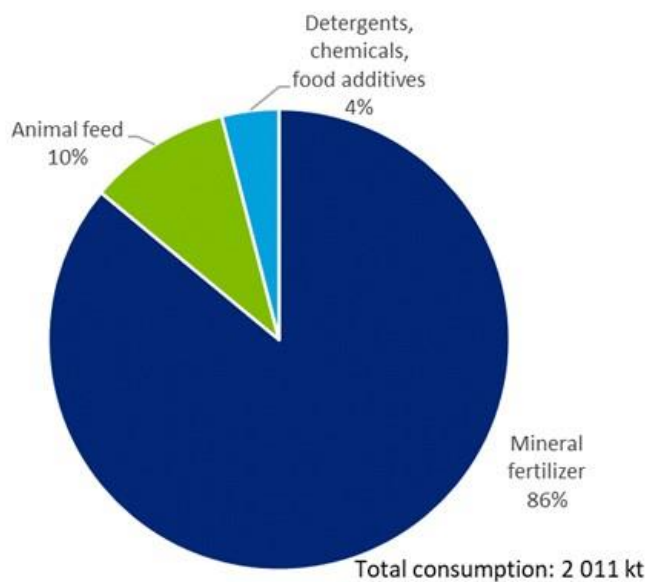
### 20.3.2 Uses and end-uses of phosphate rock and phosphorus in the EU

Phosphorus is a vital part of plant and animal nourishment. Globally 91% of phosphate rock is utilised for production of fertilisers, while in the EU this share is 85%. Other applications include animal feed, detergents, food additives and other chemicals, see Figure 312.

For fertilisers phosphate is generally used with the other two main nutrients (sodium, potassium) and often with other nutrients (sulfur, magnesium, calcium, copper etc.).

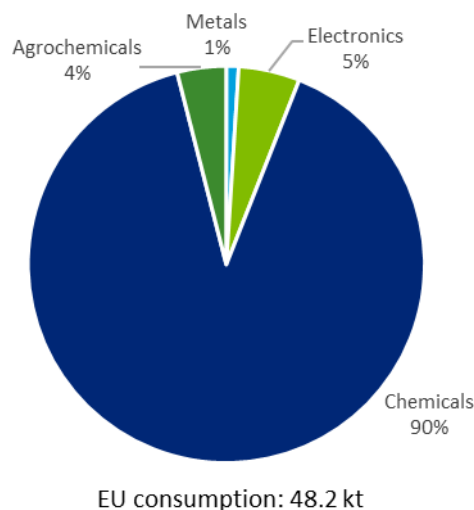
Approximately, 10% of phosphate rock used in the EU is in the production of nutritional supplements for animal feed mainly in form of mono- and dicalcium phosphate (Tercero et al., 2018). There is no substitute for use of phosphorus in food chains.

A smaller fraction around 4% of phosphate rock is used in the production of detergents and other chemicals. There are different detergents and their composition depends on their application purpose; laundry and dishwasher detergents contain phosphate mainly in the form of sodium tripolyphosphate (STPP). In 2018, its use in detergents has experienced a strong reduction due to concerns related with rising levels of phosphorus in surface waters which causes eutrophication (Tercero et al., 2018).



**Figure 312: EU end uses of phosphate rock (in  $P_2O_5$  content). Average figures for 2012-2016 (ESPP, 2019).**

Elemental phosphorus, obtained from phosphate rock, is used for the production of chemicals (e.g. flame retardants, oil additives, industrial water treatment, emulsifying agents). Around 5% of world phosphate rock production is used in applications other than agriculture (other than fertilisers and animal food). The “industrial” applications include: lubricant additives, pharmaceuticals (both in the pharmaceutical molecule, and as intermediates in drug synthesis), agrochemicals, anti-scaling agents, detergents, flame retardants, oil additives, industrial water treatment, emulsifying agents, matches and pyrotechnics, nickel plating, asphalt and plastic additives, catalysts, luminescent materials, metal extraction (most of the world’s cobalt is produced using a phosphorus intermediate) (ECI, 2019).



**Figure 313: EU end uses of elemental phosphorus, in P<sub>4</sub>. Average figures for 2012-2016 (ECI, 2019), (ESPP, 2019).**

The calculation of economic importance is based on the use of the NACE 2-digit codes and the value added at factor cost for the identified sectors (Table 137).

**Table 137: Phosphate rock or white phosphorus applications, 2-digit NACE sectors, associated 4-digit NACE sectors and value added per sector (Data from the (Eurostat, 2019a))**

Applications	2-digit NACE sector	4-digit NACE sector	Value added of sector (millions €)
Animal feed	C10 - Manufacture of food products	All subsectors (meat, starch, dairy etc.)	155 880
Fertilisers, chemicals and detergents	C20 - Manufacture of chemicals and chemical products	20.15 Manufacture of fertilisers and nitrogen compounds	105 514
Metals	C25 - Manufacture of fabricated metal products, machinery and equipment	25.61 Treatment and coating of metals	148 351
Electronic parts	C26 - Manufacture of computer, electronic and optical products	26.11 Manufacture of electronic components	65 703

### 20.3.3 Substitution

There are no substitutes for phosphate rock for the production of fertilisers. (ESPP, 2019) The existing opportunities for other sources of phosphorus are represented by the applied end-of-life recycling rate of 17% (see section on secondary materials) of rather than a reduction of supply risk from substitution.

Substitution of elemental phosphorous P<sub>4</sub> and thus also of phosphate rock in other chemical applications is also set to 0% because many of these are specific phosphorus chemicals where no substitute is available to date (ESPP, 2019) (example: fire safety,

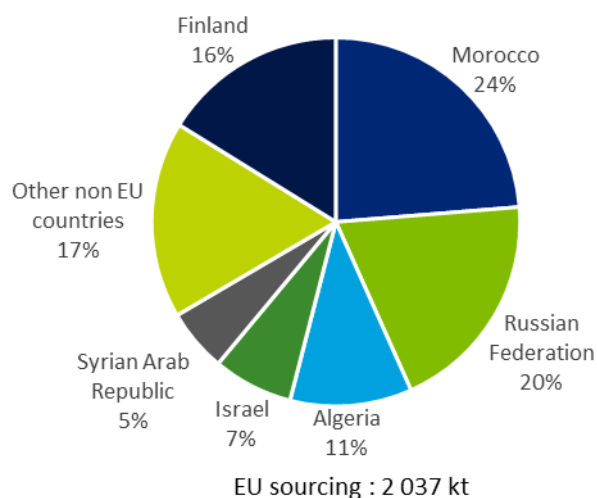
where phosphorus-based flame retardants are developing to replace halogenated substances).

## 20.4 Supply

### 20.4.1 EU supply chain

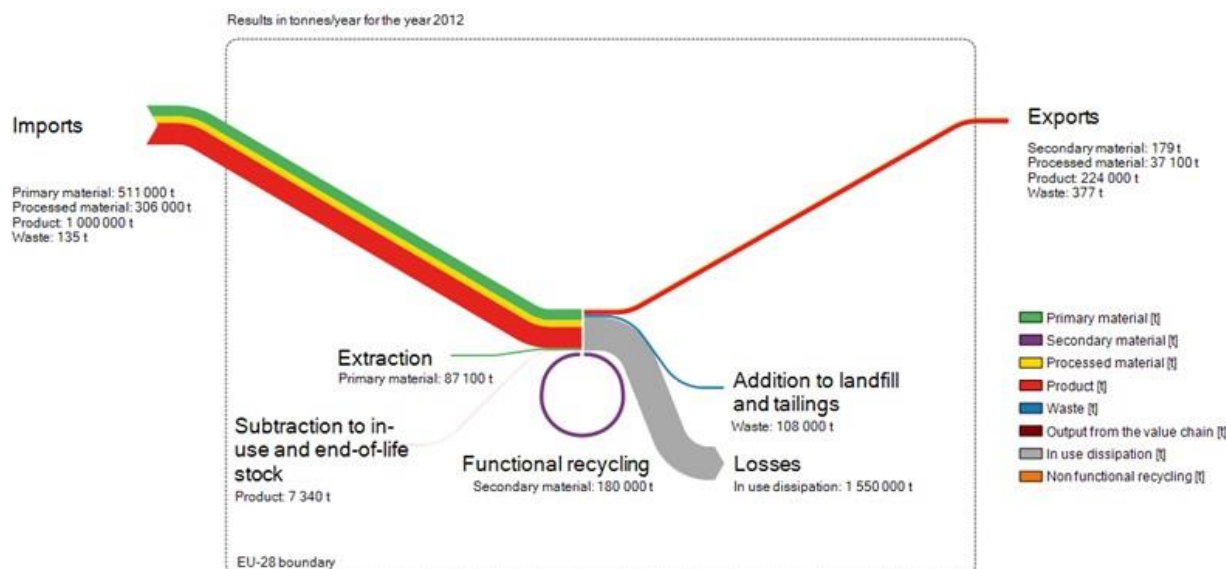
The EU is an exporter of high value products and food products, between 6% and 7% of the value of total external EU exports per year (Eurostat, 2019c). All agro-food related activities cannot take place without a supply of phosphorous into the agricultural system.

Europe's import reliance of phosphate rock or phosphoric acid was between 2012 to 2016 around 84%. The recurring comment is that these figures do not capture use, stock accumulation and extraction potential of phosphorous in the downstream lifecycle stages of these materials. Therefore, care is needed when interpreting the dependency of the EU on external supply of phosphorus to cover EU necessities. The EU sourcing (domestic production + imports) for phosphate rock is presented in Figure 314. An annual average 329.6 kt of  $P_2O_5$  were produced in the EU between 2012 and 2016. The only currently operating mine extracting Phosphate rock in the EU is in Finland, in Siilinjärvi, explored by the company Yara International. The concentrate produced in the mine is used for phosphoric acid and fertilizer production in the adjacent plant. The resource estimate (JORC) for the Siilinjärvi deposit is 1,617 Mt of ore with  $P_2O_5$  content of 3.694% (FODD 2017).



**Figure 314: EU sourcing (domestic production + imports) of phosphate rock (in  $P_2O_5$  content), average 2012-2016 (Eurostat, 2019b).**

Figure 315 show the phosphate material flows in the EU economy from the phosphate rock 2015 MSA study conducted by Bio by Deloitte (BIO Intelligence Service, 2015).



**Figure 315: Sankey diagram showing the material flows of phosphate in the EU economy in 2012 (BIO Intelligence Service, 2015).**

Regarding white phosphorus the EU is 100% dependent from imports.

## 20.4.2 Supply from primary materials

### 20.4.2.1 Geological occurrence/exploration

The abundance in the earth's crust of phosphorus pentoxide ( $P_2O_5$ ) is about 0.13% of the total crust, which indicates a relatively high presence of P (Rudnick & Gao, 2013). Sedimentary marine phosphorites are the principal deposits for phosphate rock. Depending on the mineralogical, textural and chemical characteristics (e.g. ore grade, impurities), as well as the local availability of water around the mining site, different refining processes are applied to obtain phosphate rock concentrates. Although these resources are found worldwide, known reserves are highly concentrated (over 70% in Morocco). It is estimated that world resources of phosphate rock total 300,000 million tonnes; known world reserves are shown in Table 138. The biggest deposits are located in northern Africa, China, the Middle East, and the US. Large deposits of phosphates are also located on the continental shelf and on seamounts in the Atlantic and Pacific Oceans, but exploiting these deep-sea sources is still not considered an economically viable option. Besides the sedimentary phosphate deposits, some igneous rocks are also rich in phosphate minerals. However, sedimentary deposits are more abundant and usually higher in grade (P content, but also higher in contaminants). About 80% of the global production of phosphate rock is exploited from sedimentary phosphate deposits ((McKelvey, 2016); (Kauwenbergh, 2010)).

Exploration activities and mine expansions took place in Australia and Africa in 2011. There are two major projects in Africa: the expansion of a phosphate mine in Morocco and a new project off the Namibian coast. Smaller projects are under various stages of development in several African countries, such as Angola, Congo (Brazzaville), Guinea-Bissau, Ethiopia, Mali, Mauritania, Mozambique, Uganda, and Zambia. Expansion of production capacity was planned in Egypt, Senegal, South Africa, Tunisia, and Togo. Other development projects for new mines or expansions are on-going in Brazil, China, and Kazakhstan (Jasinski, 2016). In the EU there is a mining operating in Finland (De Ridder et al., 2012).



Apart from known geological reserves, organic sources of phosphorites are possible. Guano, bone meal or other organic sources are of less economic importance as phosphate rock sources, because of supply issues, processing costs, or simply because quantities available are much smaller.

#### 20.4.2.2 Resources and reserves

The resources are relatively abundant globally and known reserves are documented and sedimentary phosphate deposits occur on every continent (McKelvey, 1967) but known reserves are highly concentrated in a few countries, mainly Morocco, see Table 138.

Resource data for some countries in the EU are available at Minerals4EU (2019), see Table 139, but cannot be summed as they are partial and they do not use the same reporting code. For reserves, Minerals4EU (2019) only reports phosphate rock reserves in Ukraine, with 115,800 kt of apatite ore, and 4,550 kt of P<sub>2</sub>O<sub>5</sub> contained in the apatite ores according to Russian Classification (RUS)A.

**Table 138: Global known reserves of phosphate rock in year 2015 (Data from (Jasinski, 2016))**

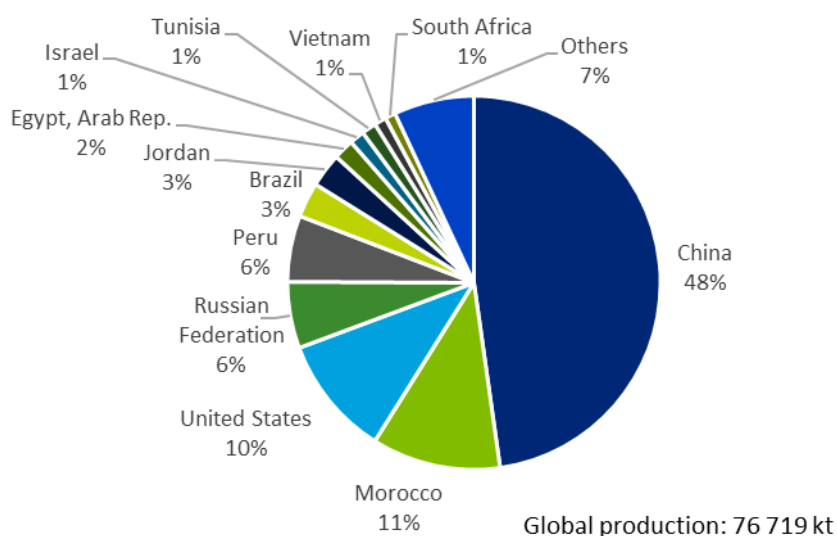
Country	Estimated phosphate rock known reserves (kt)	Percentage of total (%)
Morocco	50,000,000	73
China	3,700,000	5
Algeria	2,200,000	3
Syria	1,800,000	3
South Africa	1,500,000	2
Jordan	1,300,000	2
Russia	1,300,000	2
Egypt	1,200,000	2
United States	1,100,000	2
Australia	1,000,000	1
Saudi Arabia	960,000	1
Peru	820,000	1
Iraq	430,000	1
Brazil	320,000	0
Others (including Finland)	1,075,000	2
<i>World total (rounded)</i>	<i>68,705,000</i>	<i>100</i>

**Table 139: Resource data for the EU compiled in the European Minerals Yearbook at Minerals4EU (2019)**

Country	Reporting code	Quantity	Unit	Grade	Code Resource Type
Spain	Adapted version of the USGS Circular 831 of 1980	30.8	Mt	11.78%	Proven reserves
UK	None	100.7	Mt	2.19%	Historic Resource Estimates
Finland	JORC	540	Mt	4%	Total
Norway	JORC	14.6	Mt	5.18%	Indicated
Ukraine	Russian Classification	131,930	kt	-	(RUS)P1
Estonia	Nat. rep. code	2,935.74	kt	-	Measured+Indicated
Greece	USGS	500	kt	10-25%	Measured
Serbia	JORC	72	Mt	9%	Total

### 20.4.2.3 World mine production

The global annual production of phosphate rock between 2012 and 2016 was 76,719 kt of P<sub>2</sub>O<sub>5</sub>, on average (WMD 2019). The production of phosphate rock is concentrated in a limited number of countries. Although most phosphate rock resources are located in Morocco, China is the dominant producer, however with limited exports. The largest phosphate rock mining countries are shown in Figure 316, with 48% of the global production in China, 11% in Morocco and 10% in the US leading the producing countries, manufacturing respectively, averaged over 2012 to 2016. Finland produced 329 kt of P<sub>2</sub>O<sub>5</sub> per year on average between 2012 and 2016. This can be expected to change in the future because of the concentration of known reserves in Morocco and the progressive depletion of exploitable reserves in the US.



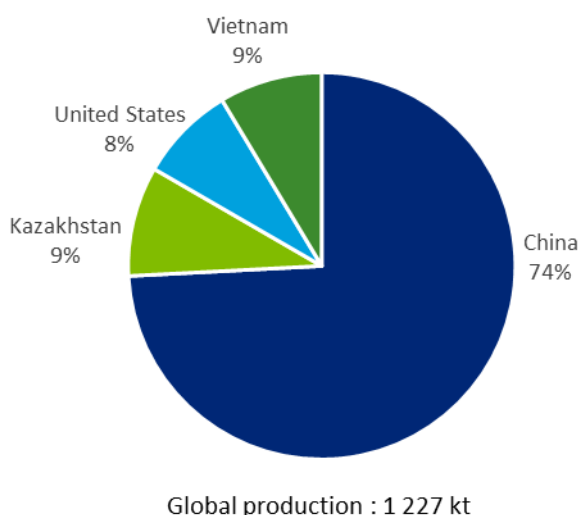
**Figure 316: Global mine production of phosphate rock, averaged over 2012-2016 ((WMD, 2019)).**

SCREEN project listed the most relevant industrial actors benefiting phosphate rock, see Table 140.

**Table 140: Some of the largest industrial actors benefiting phosphate ores (Yang et al., 2018).**

Company	Mine site (location)
Vale	Bayóvar (Sechura, Peru)
	Catalão (Goiás, Brazil)
OCP	Benguérir (Morocco)
	Youssoufia (Morocco)
	Khouribga (Morocco)
	Boucraâ (Western Sahara)
Mosaic Co.	Four Corners (Florida, US)
	South Ford Meade (Florida, US)
	South Pasture (Florida, US)
	Wingate Creek (Florida, US)
	Hopewell (Florida, US)
China Molybdenum Co.	Ltd Chapadão (Goiás, Brazil)
Sinochem Yunlong Co., Ltd.	Aurora (North Carolina, US)
Nutrien (merger of Agrium and Potash Corp.)	Dry Valley (Idaho, US)
	Swift Creek (Florida, US)
P4 Production, LLC.	Blackfoot Bridge (Idaho, US)
Foskor	Phalaborwa (South Africa)
Yara	Siilinjärvi (Finland)
Apatit	Kola (Russia)
EuroChem	Kovdorskiy GOK (Russia)

The precise global production of elemental phosphorus is not known, it was estimated to be close to 1,200 kt per year (between 2012, 2013 and 2016). The distribution of global production of elemental phosphorus is shown in Figure 317. The main producer in the world is China and its production capacity had increased at an accelerated pace between 2002-2012 (with 9% increase every year), but is now slowing down due governmental measures to protect phosphate resources. Even then, in 2016 China achieved 87% of the worlds production (IHS, 2017). Production in the United States was limited to one plant (8% per year, averaged over 2012-2016). The only other operating elemental phosphorus facilities in the world were in Kazakhstan and Vietnam (McKelvey, 2016).



**Figure 317: Global elemental phosphorus production, average of 2012, 2013 and 2016 (IHS, 2017).**

Elemental phosphorus is produced only outside the EU. SCRREEN project listed the most relevant elemental phosphorus manufactures, see Table 141.

**Table 141: Some of the largest elemental phosphorus manufactures .**

<b>Company</b>	<b>Plant location</b>
Yunphos (Taixing) Chemical Co., Ltd.	China
Changzhou Qishuyan Fine Chemical Co. Ltd	China
5-Continent Phosphorus Co. Ltd.	China
Taj Pharmaceuticals Ltd.	India
UPL Europe Ltd.	India
Viet Hong Chemical and Trading Co. Ltd	Vietnam
Kazphosphate LLC	Kazakhstan

### 20.4.3 Supply from secondary materials/recycling

For its applications in agriculture, phosphate rock can be replaced by secondary sources of phosphorous such as manure, sewage and food waste (biogenic waste flows).

The EoL-RIR (End-of-Life Recycling Input Rate) should translate the % by which recycling of biogenic waste flows substitutes the use of mineral phosphate fertilisers (i.e. primary input material). An EoL-RIR of 17% was assumed for the criticality assessment based on the raw material system analysis performed in 2015 (BIO Intelligence Service, 2015). Various flows of phosphorus can replace the input from primary phosphate rock. The total size of this flow was estimated by to be around 180 kt of phosphorus in in 2012 (BIO Intelligence Service, 2015) (listed as "G.1.2, the production of secondary material from post-consumer functional recycling in EU sent to manufacture in EU").

Other recycling rates indicators are also reported in the literature. Van Dijk et al. (2016) estimated recycling rates of 70% in crop production, 24% in animal production, 52% in food production and around 76% in non-food applications of phosphorous, in 2015.

There is evidence that increased flows of secondary phosphorous could potentially be extracted and recycled from current production and consumption flows ((Sutton, RISE foundation, 2016); (van Dijk et al., 2016); (Leip et al., 2015). Estimates of potential sources of secondary phosphorous are provided by the DONUTSS project (2019). Fresh pig manure contains 0.4% of P<sub>2</sub>O<sub>5</sub>, whereas dry pig manure has 5% and after incineration the ash contains 18.8%. For chicken litter, these numbers are 1.9%, 3.9% and 15.3% respectively. Kitchen waste generally contains 18.8% of P<sub>2</sub>O<sub>5</sub>. Garden waste, another source from households, is much lower given a high cellulose and water content. Additionally, according with the literature the total amount of phosphorus in livestock manure potentially available for recycling in the EU28 from animal production is around 1,749 Mt phosphorus per year (van Dijk et al., 2016) to 1,977 Mt of phosphorus per year (Hermann, 2011).

However, today there is no useable data on the rate of effective reuse of phosphorus for manures and other organic forms, which replaces the use of fertiliser or other phosphate rock derived chemicals. Therefore, there is the need to generate appropriate data and define indicators for this recycling rate, in coherence with indicators for other policies (Circular Economy/Fertilising Products Regulation, Water Framework Directive, CAP, DG Research project impacts) (ESPP, 2019).

Processes exist to potentially produce elemental phosphorus P<sub>4</sub> from phosphorus-rich waste streams (e.g. ICL Recophos process to produce P<sub>4</sub> from sewage sludge incineration ash or meat and bone meal ash) but these are today only at the pilot scale and no industrial installation is yet under construction, nor operational, neither in the EU nor elsewhere (ESPP, 2019).

Several european countries have created legislation to ensure phosphate recovery, examples of such countries include Germany, Finland and Switzerland and the same is being considered.

**Table 142: Material flows relevant to the EOL-RIR of phosphate rock data from 2012, tonnes of P (BIO Intelligence Service, 2015)**

MSA Flow	Value (t)
B.1.1 Production of primary material as main product in EU sent to processing in EU	70 200
B.1.2 Production of primary material as by product in EU sent to processing in EU	0
C.1.3 Imports to EU of primary material	511 000
C.1.4 Imports to EU of secondary material	0
D.1.3 Imports to EU of processed material	306 000
E.1.6 Products at end of life in EU collected for treatment	271 000
F.1.1 Exports from EU of manufactured products at end-of-life	377
F.1.2 Imports to EU of manufactured products at end-of-life	135
G.1.1 Production of secondary material from post consumer functional recycling in EU sent to processing in EU	0
G.1.2 Production of secondary material from post consumer functional recycling in EU sent to manufacture in EU	180 000

#### 20.4.4 Processing of phosphate rock

The most phosphate rock production worldwide is extracted using opencast dragline or open-pit shovel/excavator mining methods, e.g. in the United States, Morocco, Russia and China. During surface mining, overburden is drilled, blasted, and removed by dragline to the side of the mining area for subsequent reclamation. Very large draglines, electric shovels, and bulldozers recover the upper ore body. The intercalating limestone layer is then blasted and removed to expose the phosphate bed, which is loaded onto special large volume trucks (MEC, 2016).

Further processing of phosphate rock is needed to produce elemental phosphorus. Elemental phosphorus may be made by several methods. In one process tri-calcium phosphate, the essential ingredient of phosphate rock, is heated in the presence of carbon and silica in an electric furnace or fuel fired furnace, elementary phosphorus is liberated as vapour and may be collected under phosphoric acid, an important compound in making super-phosphate fertilisers (ECI, 2019). Worldwide, a gradual shift to manufacturing high-purity phosphoric acid from wet process acid has taken place because it has lower production costs and none of the hazardous waste disposal issues that are associated with elemental phosphorus (Jasinski, 2016). Production by thermal acid still accounts for more than 50% of annual world production capacity of high-purity phosphoric acid, primarily in China. Further processing of elemental phosphorus will result in compounds such as phosphorus trichloride, acids, sulphides, sodium hypophosphite, phosphine, phosphides.

### 20.5 Other considerations

#### 20.5.1 Environmental and health and safety issues

The volumes of phosphorous that end up in soil and ground water considerably affect the biochemical processes in a negative way. Especially, aquatic ecosystems are affected due to the process of eutrophication, resulting in oxygen depletion. This has in turn an effect on biodiversity, since aquatic animal populations are affected by invasive new species that benefit from different resource balances (e.g. algae) (Sutton et al., 2013).

For example, in several EU member states, phosphorus discharge into the environment is the principal factor (other than morphological modification) causing freshwater bodies to fail to achieve EU Water Framework Directive quality objectives (Leaf, 2015).

Elemental phosphorus is the probably most dangerous form of phosphorus that is known to us. White phosphorus is highly reactive (it was used in phosphorus bombs of the Second World War) and poisonous and significant exposure can be fatal (Lenntech, 2016). For this

reason, elemental phosphorus P<sub>4</sub> is usually reacted immediately on production to other “holding derivatives” (usually PCl<sub>4</sub>), these derivatives can then be transported and used to produce the different phosphorus chemicals for which P<sub>4</sub> is a necessary raw material. The energy requirement of existing elemental phosphorus production techniques is high. Each tonne of phosphorus produced requires about 14 MWh (ECI, 2019), which is comparable with the average electricity requirement of a tonne of aluminium.

It is important to highlight that there is different composition of phosphate rock ores due to the nature of their sedimentary sources. Due to its use in fertilisers production there are concerns related with soil contamination with heavy metals coming from Phosphate ores such as cadmium. The Fertilising Products Regulation introduces limits for heavy metals, such as cadmium, in phosphate fertilisers to reduce potential health and environmental risks (Regulation (EU) 2019/1009).

## 20.6 Comparison with previous EU assessments

Phosphate rock was first assessed in the CRM assessment of 2014 (European Commission, 2014). The economic importance (EI) for phosphate rock has been always above 5 and the supply risk didn't suffer substantial changes in the three exercises (see Table 143).

Elemental phosphorus was assessed for the first time in 2017 with the EI and SR (supply risk) results presented in the following table. The differences showed in the supply risk are due to small decrease on the EU supply concentration (see Table 143).

**Table 143: Economic importance and supply risk results for phosphate rock and elemental phosphorus in the assessments of 2011, 2014, 2017 and 2020 (European Commission, 2011)(European Commission, 2014)(European Commission, 2017a)**

Assessment	2012		2014		2017		2020	
	EI	SR	EI	SR	EI	SR	EI	SR
Phosphate rock	Not assessed		5.8	1.1	5.1	1.0	5.64	1.09
White Phosphorus	Not assessed		Not assessed		4.4	4.1	5.30	3.62

## 20.7 Data sources

The CN codes used for the trade analysis are 25101000 and 25102000. These product groups describe ground and unground natural calcium phosphates, natural aluminium calcium phosphates and natural and phosphatic chalk. The CN code used for the trade analysis of elemental phosphorus is 28047000, and is labelled Phosphorous.

The data has a very strong coverage, on EU level, is available for time series and updated at regular intervals and is publicly available.

The data on the precise global production of elemental phosphorus is not fully available; it was possible to estimate an average figure taking into account the previous assessment from 2017 and two other sources (IHS, 2017). This value was confirmed in the CRM validation workshop, 12<sup>th</sup> September 2019.

## 20.7.1 Data sources used in the factsheet

BGS (2019) World mineral statistics data, British Geological Survey, <https://www.bgs.ac.uk/mineralsuk/statistics/wms.cfc?method=searchWMS>

BIO Intelligence Service. (2015). Study on Data for a Raw Material System Analysis: Roadmap and Test of the Fully Operational MSA for Raw Materials. Retrieved from <https://ec.europa.eu/jrc/en/scientific-tool/msa>

De Ridder, M., De Jong, S., Polchar, J., & Lingemann, S. (2012). Risks and Opportunities in the Global Phosphate Rock Market. Retrieved from [www.hcss.nl](http://www.hcss.nl)

DERA. (2019). Preismonitor.

DERA and BGR. (2019). Preismonitor September 2019.

ECHEMI. (2019). White Phosphorus Price Market Analysis - Echemi. Retrieved November 10, 2019, from <https://www.echemi.com/productsInformation/pd20161125160542213-white-phosphorus.html>

ECI. (2019). Phosphorus. Retrieved November 10, 2019, from <http://essentialchemicalindustry.org/chemicals/phosphorus.html>

European Commission. (2011). Critical raw materials. Retrieved July 8, 2019, from [https://ec.europa.eu/growth/sectors/raw-materials/specific-interest/critical\\_en](https://ec.europa.eu/growth/sectors/raw-materials/specific-interest/critical_en)

European Commission. (2014). Report on critical raw materials for the EU - Critical raw materials profiles. Retrieved from <https://ec.europa.eu/docsroom/documents/11911/attachments/1/translations/en/renditions/pdf>

European Commission. (2017a). Study on the review of the list of critical raw materials. Critical Raw Material Factsheets. <https://doi.org/10.2873/398823>

European Commission. (2017b). Study on the review of the list of critical raw materials. Non-critical raw materials factsheets. <https://doi.org/10.2873/876644>

European Commission. (2019). Negotiations and agreements - Trade. Retrieved July 7, 2019, from <http://ec.europa.eu/trade/policy/countries-and-regions/negotiations-and-agreements/>

European Sustainable Phosphorus Platform ESPP. (2019). Personal Communication.

Eurostat. (2019a). Annual detailed enterprise statistics for industry (NACE Rev. 2, B-E). Retrieved July 7, 2019, from [https://ec.europa.eu/eurostat/en/web/products-datasets/-/SBS\\_NA\\_IND\\_R2](https://ec.europa.eu/eurostat/en/web/products-datasets/-/SBS_NA_IND_R2)

Eurostat. (2019b). Easy Comext database. Retrieved from <http://epp.eurostat.ec.europa.eu/newxtweb/>

Eurostat. (2019c). Statistics on the production of manufactured goods (PRODCOM NACE Rev.2). Retrieved July 14, 2019, from Prodcom - Statistics by Product website: <https://ec.europa.eu/eurostat/web/prodcom>

Food and Agriculture Organization of the United Nations (FAO). (2019). World fertilizer trends and outlook to. Retrieved from [http://www.ghbook.ir/index.php?name=&option=com\\_dbook&task=readonline&book\\_id=13650&page=73&chckhashk=ED9C9491B4&Itemid=218&lang=fa&tmpl=component](http://www.ghbook.ir/index.php?name=&option=com_dbook&task=readonline&book_id=13650&page=73&chckhashk=ED9C9491B4&Itemid=218&lang=fa&tmpl=component)

Hermann, L. (2011). How energy from livestock manure can reduce eutrophication. *EcoRegion Perspectives, Fourth Issue: Sustainable Agriculture in the Baltic Sea Region in Times of Peak Phosphorus and Global Change*, (4).

IHS. (2017). *Chemical Economics Handbook: Phosphorus and Phosphorus Chemicals*.

Indexmundi. (2019). Rock Phosphate - Monthly Price (Euro per Metric Ton) - Commodity Prices - Price Charts, Data, and News - IndexMundi. Retrieved November 9, 2019, from <https://www.indexmundi.com/commodities/?commodity=rock-phosphate&months=240&currency=eur>

International Fertilizer Association. (2019). *Fertilizer Outlook 2019 – 2023*. IFA Annual Conference, (November 2016), 26–28.

International Fertilizer Development Center (IFDC). (2010). *Growing Food*. Retrieved from [www.ifdc.org](http://www.ifdc.org)

Jasinski, S. M. (2016). phosphate rock 2016. Retrieved from <http://investors.mosaicco.com/>

Kauwenbergh, S. J. Van. (2010). *World Phosphate Rock Reserves and Resources*. Retrieved from [www.ifdc.org](http://www.ifdc.org)

Leip, A., Billen, G., Garnier, J., Grizzetti, B., Lassaletta, L., Reis, S., ... Westhoek, H. (2015). Impacts of European livestock production: Nitrogen, sulphur, phosphorus and greenhouse gas emissions, land-use, water eutrophication and biodiversity. *Environmental Research Letters*, 10(11). <https://doi.org/10.1088/1748-9326/10/11/115004>

Lenntech. (2016). Phosphorus (P) - Chemical properties, Health and Environmental effects. Retrieved November 11, 2019, from <https://www.lenntech.com/periodic/elements/p.htm>

LUIS TERCERO ESPINOZA, ANTONIA LOIBL, S. L., ARJAN DE KONING, E. V. D. V., & MICHAUX, S. (2018). *SCREEN D2.3 REPORT ON THE FUTURE USE OF CRITICAL RAW MATERIALS*.

McKelvey, V. E. (1967). Phosphate deposits. In *Bulletin*. <https://doi.org/10.3133/b1252D>

MEC. (2016). *Phosphate Rock | Minerals Education Coalition*. Retrieved November 10, 2019, from <https://mineralseducationcoalition.org/minerals-database/phosphate-rock/>

Minerals4EU. (2015). *European Minerals Yearbook*. Retrieved July 9, 2019, from [http://minerals4eu.brgm-rec.fr/m4eu-yearbook/theme\\_selection.html](http://minerals4eu.brgm-rec.fr/m4eu-yearbook/theme_selection.html)

Monnet, A., & Ait Abderrahim, A. (2018). *SCREEN D2.2 Report on major trends affecting future demand for critical raw materials*. In *SCREEN*.

OECD. (2019). *Export restrictions on Industrial Raw Materials*. Retrieved July 5, 2019, from [https://qdd.oecd.org/subject.aspx?Subject=ExportRestrictions\\_IndustrialRawMaterials](https://qdd.oecd.org/subject.aspx?Subject=ExportRestrictions_IndustrialRawMaterials)

Project, D. (n.d.). *European Sustainable Phosphorus Platform - DONUTSS*. Retrieved November 10, 2019, from <https://phosphorusplatform.eu/activities/donutss-2>

Rudnick, R. L., & Gao, S. (2013). Composition of the Continental Crust. In *Treatise on Geochemistry: Second Edition (2nd ed., Vol. 4)*. <https://doi.org/10.1016/B978-0-08-095975-7.00301-6>

Sutton, M. A. (RISE foundation). (2016). *Nutrient Recovery and Reuse (NRR) in European agriculture A review of the issues, opportunities, and actions*. Retrieved from [www.risefoundation.eu](http://www.risefoundation.eu)



Sutton M.A., Bleeker A., Howard C.M., Bekunda M., Grizzetti B., de Vries W., V., Grinsven H.J.M., Abrol Y.P., Adhya T.K., Billen G., Davidson E.A, Datta A., D. R., Erisman J.W., Liu X.J., Oenema O., Palm C., Raghuram N., Reis S., Scholz R.W., S., T., Westhoek H. & Zhang F.S., with contributions from Ayyappan S., B. A. F., Bustamante M., Fowler D., Galloway J.N., Gavito M.E., Garnier J., G. S., Hellums D.T., Holland M., Hoysall C., Jaramillo V.J., Klimont Z., Ometto J.P., P., ... Singh B., Singh U., Y. X. Y. & Z. Y. (2013). Our Nutrient World: The challenge to produce more food and energy with less pollution (E. on behalf of the G. Centre for Ecology and Hydrology & P. on N. M. and the I. N. Initiative, Eds.). Retrieved from [www.unep.org](http://www.unep.org)

Tercero, L., Stotz, H., Otmar Deubzer, García, R. B., Lepe, G. R., Bilewska, K., ... Hu, X. (2018). SCRREEN D5.1 Critical Raw Material substitution profiles. In SCRREEN - D5.1. Retrieved from <http://screen.eu/wp-content/uploads/2018/05/SCRREEN-D5.1-CRM-profiles.pdf>

van Dijk, K. C., Lesschen, J. P., & Oenema, O. (2016). Phosphorus flows and balances of the European Union Member States. *Science of the Total Environment*, 542, 1078–1093. <https://doi.org/10.1016/j.scitotenv.2015.08.048>

WMD (2019) World Mining Data 2019, Reichl, C.; Schatz, M; Zsak, G. Iron and Ferro Alloy Metals, non Ferrous Metals, Precious Metals, Industrial Minerals, Mineral Fuels. Austrian Federal Ministry of Sustainability and Tourism. [online] Available at: [www.en.bmwf.gv.at/Energy/WorldMiningData/Seiten/default.aspx](http://www.en.bmwf.gv.at/Energy/WorldMiningData/Seiten/default.aspx)

Yang, J., Hu, X., Sundqvist, L., Eriksson, J., Yli-Rantala, E., Bacher, J., ... Retegan, T. (2018). SCRREEN D4.1 Production technologies of CRM from primary. Retrieved from [www.screen.eu](http://www.screen.eu)

## **20.7.2 Data sources used in the criticality assessment**

European Sustainable Phosphorus Platform ESPP. (2019). Personal Communication

Eurostat. (2019b). Easy Comext database. Retrieved from <http://epp.eurostat.ec.europa.eu/newxtweb/>

OECD. (2019). Export restrictions on Industrial Raw Materials. Retrieved July 5, 2019, from [https://qdd.oecd.org/subject.aspx?Subject=ExportRestrictions\\_IndustrialRawMaterials](https://qdd.oecd.org/subject.aspx?Subject=ExportRestrictions_IndustrialRawMaterials)

European Commission. (2019). Negotiations and agreements - Trade. Retrieved July 7, 2019, from <http://ec.europa.eu/trade/policy/countries-and-regions/negotiations-and-agreements/>

van Dijk, K. C., Lesschen, J. P., & Oenema, O. (2016). Phosphorus flows and balances of the European Union Member States. *Science of the Total Environment*, 542, 1078–1093. <https://doi.org/10.1016/j.scitotenv.2015.08.048>

WMD (2019) World Mining Data 2019, Reichl, C.; Schatz, M; Zsak, G. Iron and Ferro Alloy Metals, non Ferrous Metals, Precious Metals, Industrial Minerals, Mineral Fuels. Austrian Federal Ministry of Sustainability and Tourism. [online] Available at: [www.en.bmwf.gv.at/Energy/WorldMiningData/Seiten/default.aspx](http://www.en.bmwf.gv.at/Energy/WorldMiningData/Seiten/default.aspx)

## **20.8 Acknowledgments**

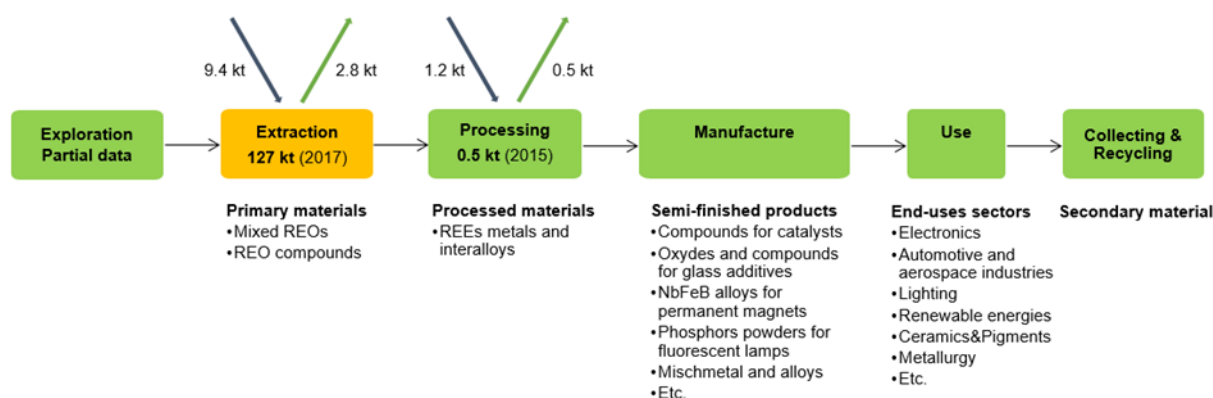
---

This factsheet was prepared by the JRC. The authors would like to thank the European Sustainable Phosphorus Platform, Chris Thornton and Ludwig Hermann, the EC Ad Hoc

Working Group on Critical Raw Materials and all other relevant stakeholders for their contributions to the preparation of this Factsheet.

# 21 RARE EARTH ELEMENTS (REE)

## 21.1 Overview



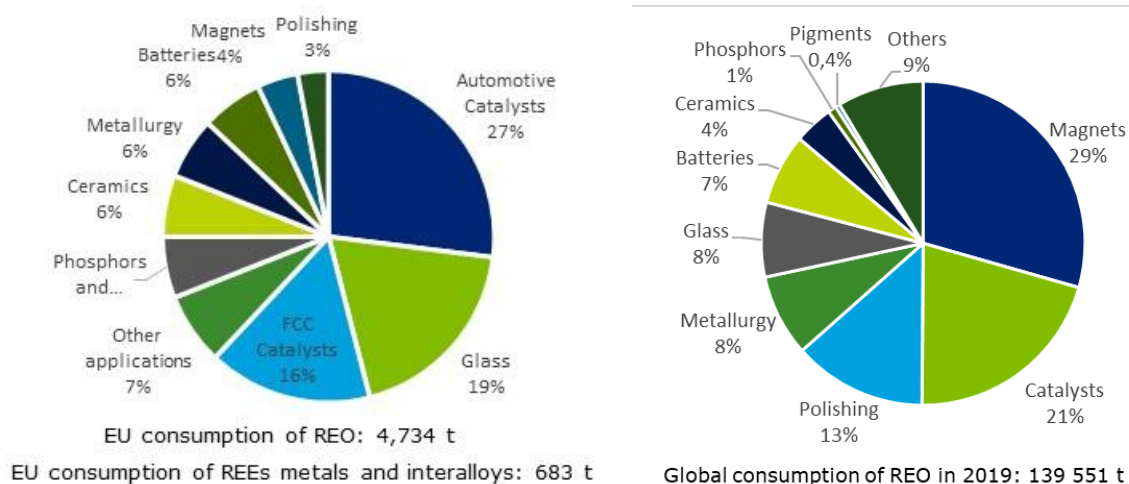
**Figure 318: Simplified value chain for REE. Average 2016-2018 (WMD, 2019) (Eurostat, 2019).**

The Rare Earth Elements (REE) are a group of 17 elements, comprising the elements scandium (Sc), yttrium (Y) and the 15 lanthanides (elements no. 57-71), as defined by the International Union of Pure and Applied Chemistry (IUPAC, 2005). The lanthanide group comprises: lanthanum (La), cerium (Ce), praseodymium (Pr), neodymium (Nd), promethium (Pm), samarium (Sm), europium (Eu), gadolinium (Gd), terbium (Tb), dysprosium (Dy), holmium (Ho), erbium (Er), thulium (Tm), ytterbium (Yb) and lutetium (Lu). Yttrium (Y, no. 39) and scandium (Sc, no. 21) share physical and chemical properties with the lanthanoides. However, only yttrium is to be treated together with REE, as it is found in the same ore deposits and shares a great part of REE value chain. Scandium is treated separately in the EU Critical raw materials assessment as it is mainly sourced more economically from bauxite and has specific industrial properties. Promethium which has no stable isotope in nature is not considered in this assessment. For the purpose of the assessment, the REE are split into two groups, the Light Rare Earth Elements (LREE - La, Ce, Pr, Nd, Sm) and Heavy Rare Earth Elements (HREE - Eu, Gd, Tb, Dy, Ho, Er, Tm, Yb, Lu, Y), both for physico-chemical and commercial reasons.

EU CRM assessment addresses two stages of REE products. At the first stage, REE are assessed in the form of mixes of rare earth oxides (REO) or low purity single REO ores and concentrates (this roughly corresponds to mining and first stages of processing/separation) (CN codes used: 28461000, 28469010 and 28469020). The second stage considers high purity single REE in the form of metals or interalloys (this corresponds to advanced separation/refining) (CN codes used: 28053010, 28053020 and -28053030). To obtain the figures for each REE, the share of individual REE in the total EU use of REE is used.

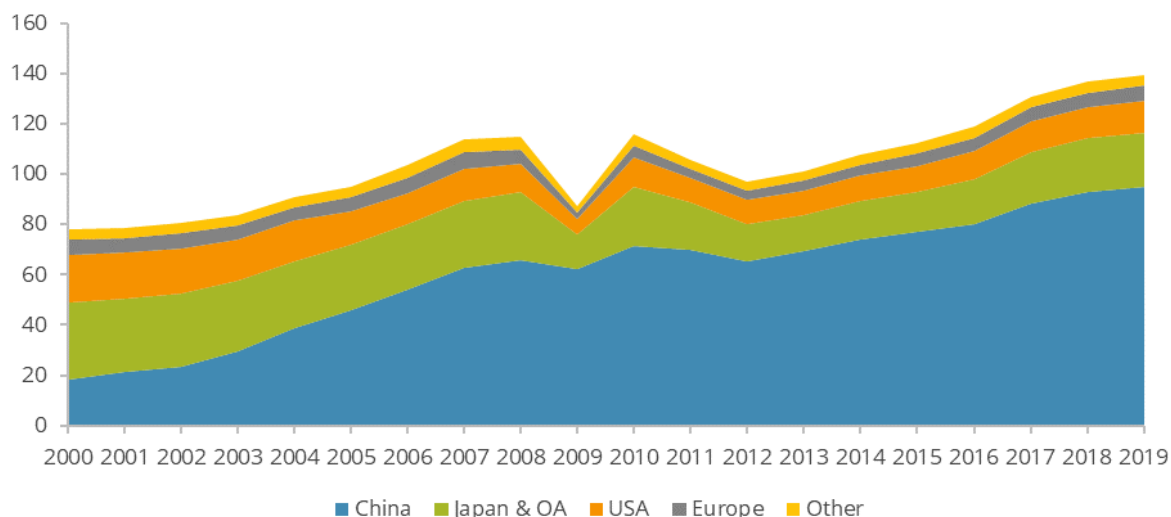
The REE are critical for the success of the EU ambitions to become climate-neutral by 2050<sup>219</sup>. They are essential in the production of high-tech, low-carbon goods such as electric vehicles, wind turbines, batteries and energy efficient light bulbs. They are also indispensable in the defence sector (laser, night vision goggles, radar equipment, etc.). Currently, the structure of the EU demand of REE, 60% used in catalysts and glass making, is different from the global demand for using 79% of REE in magnets, metal alloys, catalysts and polishing.

<sup>219</sup> [https://ec.europa.eu/clima/policies/strategies/2050\\_en](https://ec.europa.eu/clima/policies/strategies/2050_en), and the new European Green Deal.



**Figure 319: EU and global end-uses and consumption of REE (Eurostat, 2019; Machacek and Kalvig 2017: EURARE; Roskill 2019)**

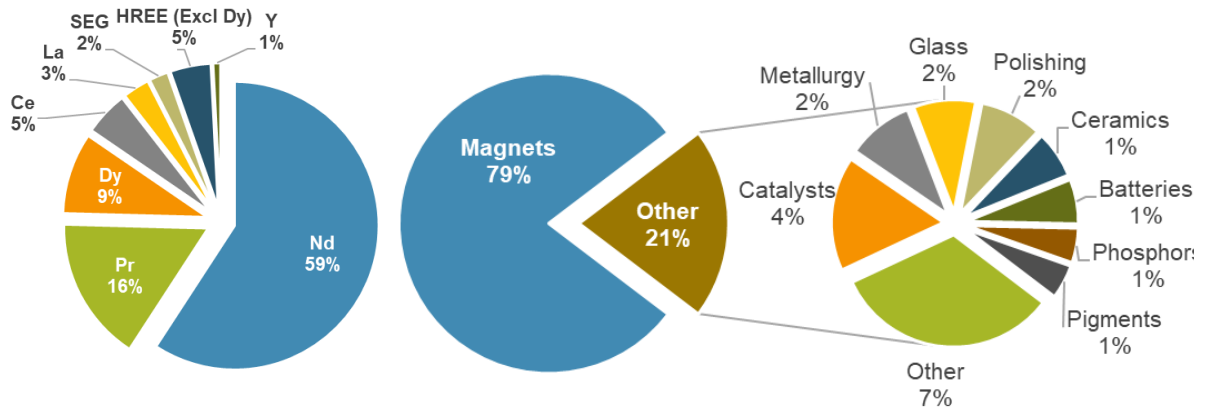
According to Roskill (2019) the global market of REE is worth 2.2 billion USD at 139,600 tonnes of rare-earth-oxide equivalent (REO<sup>220</sup>) in 2019 (while Zion Market Research, 2019 indicates 8,1 billion USD at 170,000 tonnes in 2018).



**Figure 320: Global consumption of rare earths by region in 2000-2019 in tonnes REO (Roskill 2019)**

However, determining the market and dynamics dominated by China is complicated by a limited understanding of the total production of REE-products in China (from mining to components) given that REE-production quota are official figures, which are not representative of the total production; the difficulty of obtaining estimates of the illegal share of production, i.e. the extent of the activities of grey miners; the volume and distribution of REE-stockpiles; high price volatility; difficulty with identification of types and quality of REE products (e.g. mixed rare earth carbonates, oxides or metals), further complicated by aggregated trade statistical codes for product groups; REE market imbalance with high demand for neodymium, praseodymium, dysprosium and terbium used in magnets, while there is excess of lanthanum and cerium products.

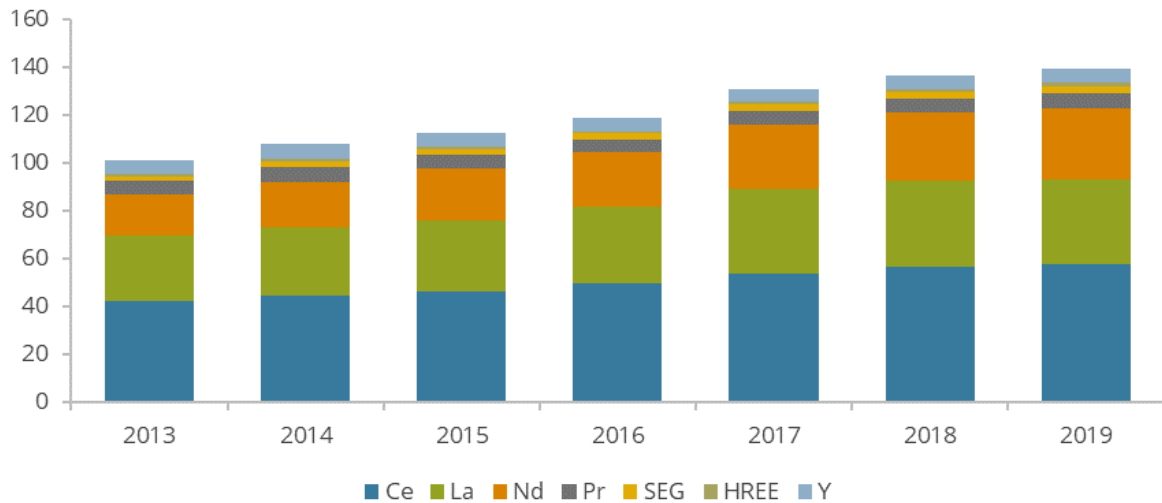
<sup>220</sup> Average conversion factor of REE metal vs. Rare Earth Oxides (REO) is estimated at 0.85 (Guyonnet et al. 2015)



**Figure 321: Estimated shares of rare earth value by element (left) and end-use (right) in 2019. Total market value: USD 2.2 billion. (Roskill, 2019)**

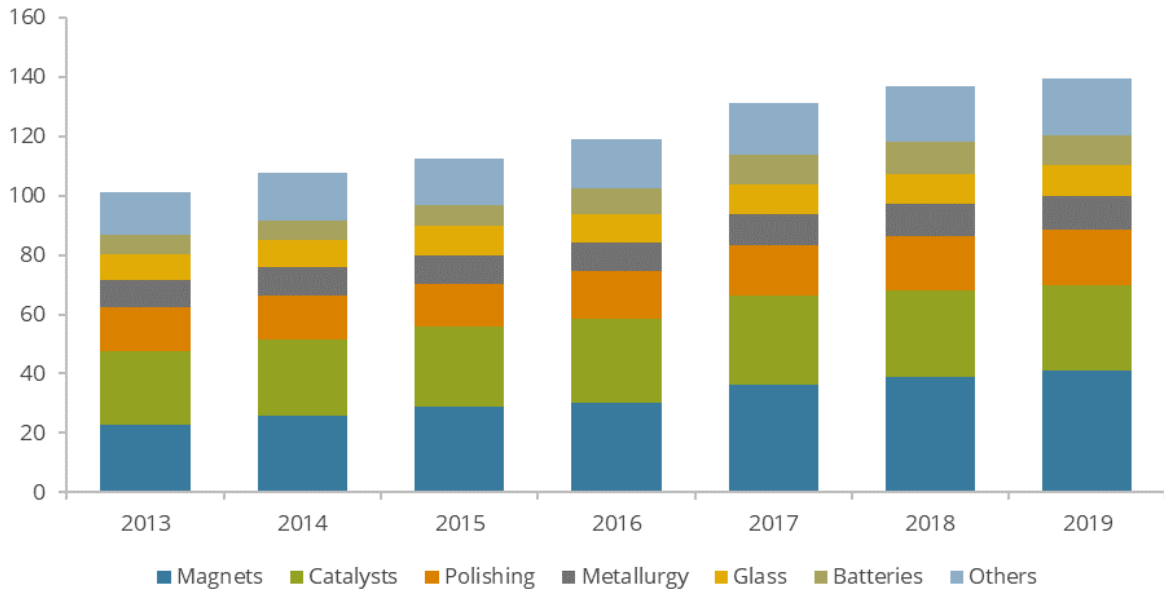
Magnet materials neodymium and praseodymium represent 75% of the total REE value and 20% of the volume; while lanthanum and cerium account for around 70% of the volume but only 8% of the value; and other elements account for around 10% of the volume and 17% of the value.

Neodymium, praseodymium, dysprosium, samarium, gadolinium and cerium are used in permanent magnets for electricity generators and electric motors. REE permanent magnets represent 29% (41,046 tonnes of REO) of total REE global demand in 2019. NdFeB magnets have a higher energy density compared to other permanent magnets, around 5-12 times that of ferrite and 3-10 times that of AlNiCo magnets. However, they are limited to an operating temperature range of between 80°C and 120°C.



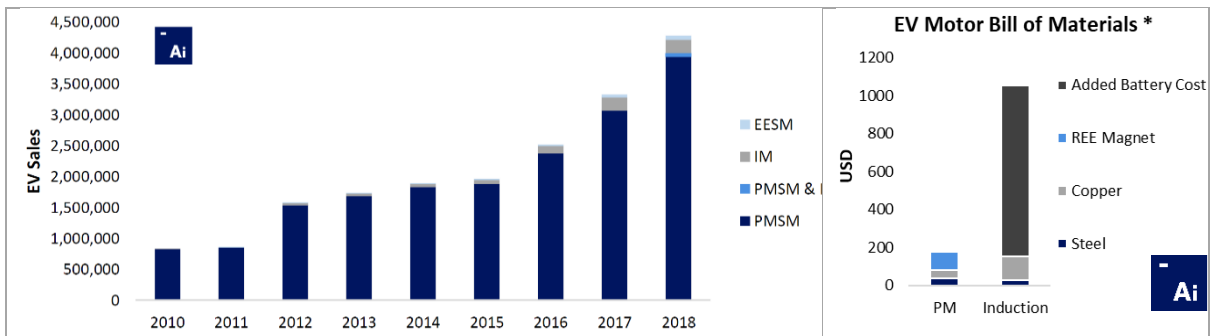
**Figure 322: Global consumption of rare earths by element in 2013-2019 in tonnes REO (Roskill 2019)**

Roskill (2019) forecast consumption increase by 3.3% per year over the next five years to 2024, reaching 163.9kt REO, while Kingsnorth (2018) expects 6-7% per year growths by 2025. Roskill (2019) expects slowing consumption to 2.1% per year over the following five years to 2029, reaching 181.5kt. China will continue to dominate global markets and lead growth in the consumption of REE ahead of rest of the world markets.



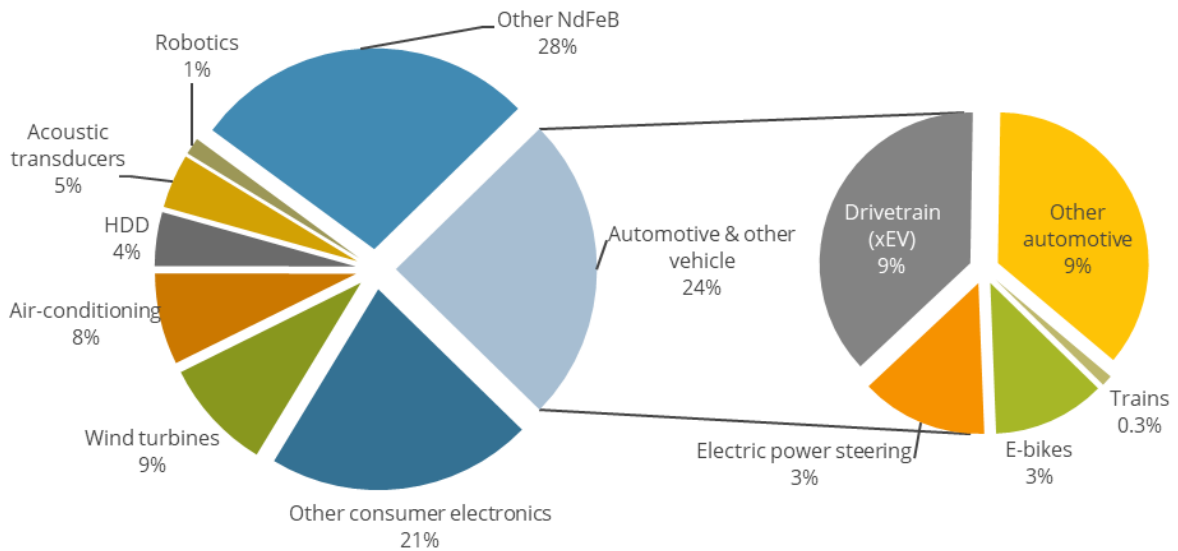
**Figure 323: Global demand for rare earths by application in 2013-2019 in tonnes REO (Roskill 2019)**

Magnets became globally leading application of rare earths demand in 2015. According to Adamas (2019), permanent magnet synchronous motors are up to 15% more efficient than induction motors and are the most power-dense type of traction motor commercially available (in kW/kg and kW/cm<sup>3</sup>). Global consumption of NdFeB magnets increased by 17% from 98,413 tonnes in 2015 to 118,047 tonnes in 2019 (Roskill 2019). NdFeB magnets represented around 66% of the permanent magnets market value of USD 20 billion in 2015 (Global Market Insights Inc., 2017). Binnemans (2018) states that for a 55-kW electric motor, 0.65 kg of Nd-Dy-Co-Fe-B alloy is required, which represents 200 g of neodymium (3.6 g/kW) and 30 g of dysprosium (0.55 g/kW) per motor. Direct-drive wind turbines contain 700–1200 kg of NdFeB magnets per MW, which corresponds to 175–420 kg of pure neodymium per MW.



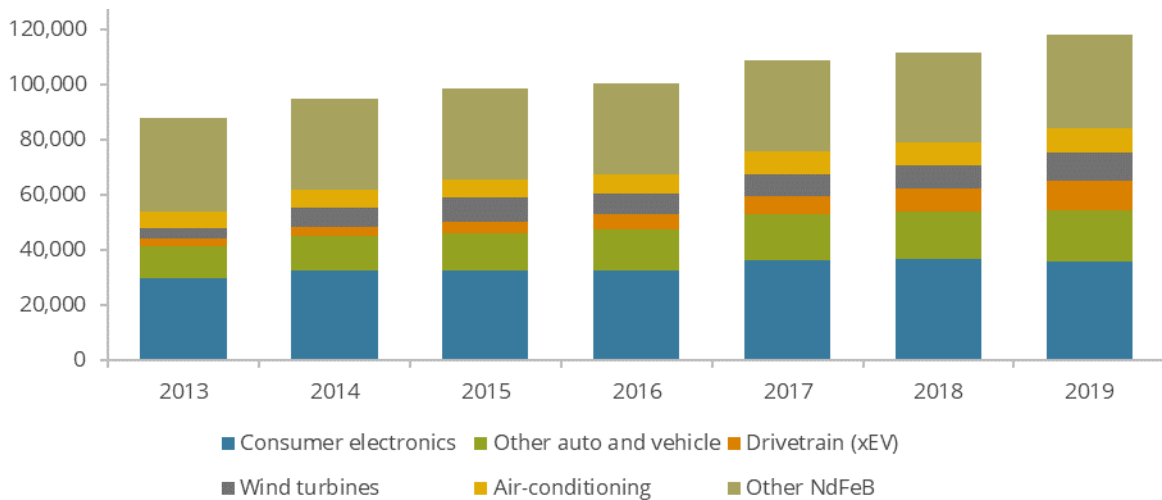
**Figure 324: Left: Over 90% of all EVs produced to-date have used permanent magnet traction motors (PMSM). IM - induction motors, EESM - electrically-excited synchronous motors. Right: Added battery pack costs incurred by an automaker using less efficient motor type (Adamas Intelligence 2019)**

According to Roskill (2019), China produced 160-180kt of REE permanent magnets in 2018 representing around 85% of global production, and has production capacity of 200kt to 300kt. The EU still has small magnet producers, but they are under pressure to move their production to China.

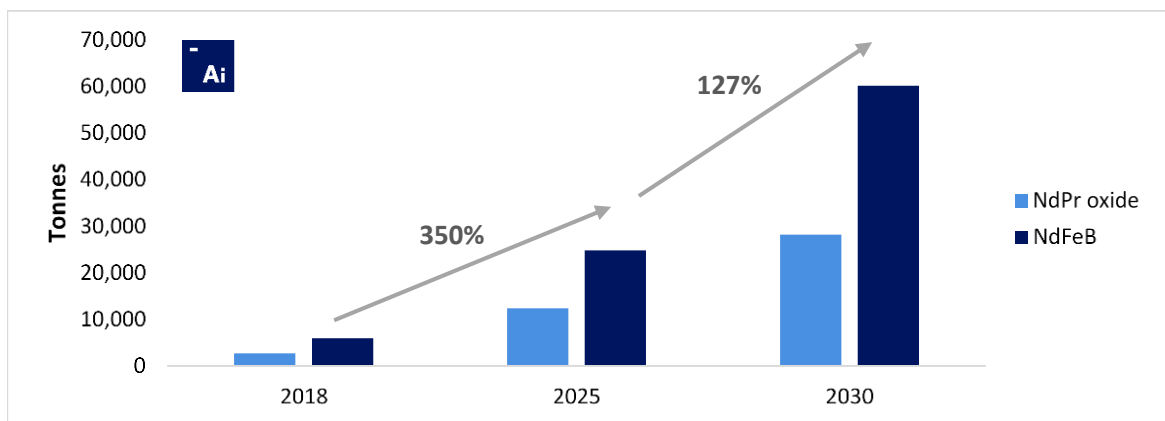


**Figure 325: Global applications for NdFeB permanent magnets in 2019 (Roskill 2019)**

Electric vehicles underpin the fundamental growth expected for NdFeB permanent magnets. According to Roskill (2019), drivetrains account for 9% of NdFeB demand in 2019 and is expected to increase at over 21% per year to account for 30% of demand by 2025 and 38% by 2029, with a total volume of 50kt and 77kt respectively. The longer-term future of drivetrain technology will be determined by new motor technologies capable of competing with permanent magnet motor efficiencies and the stability of the REE supply chain.



**Figure 326: NdFeB magnets demand per application in tonnes in 2013-2019 (Roskill 2019)**



Source: Adamas Intelligence

**Figure 327: Changes in rare earths (Nd, Pr) and NdFeB magnets demand for EV traction motors to increase by 350% between 2018 and 2025 (Adamas Intelligence, 2019)**

Europium, terbium, and yttrium are mainly used in lighting phosphors in LEDs. Yttrium, neodymium, erbium, ytterbium and thulium are dopants in laser crystals, used also in 5G frequencies generators.

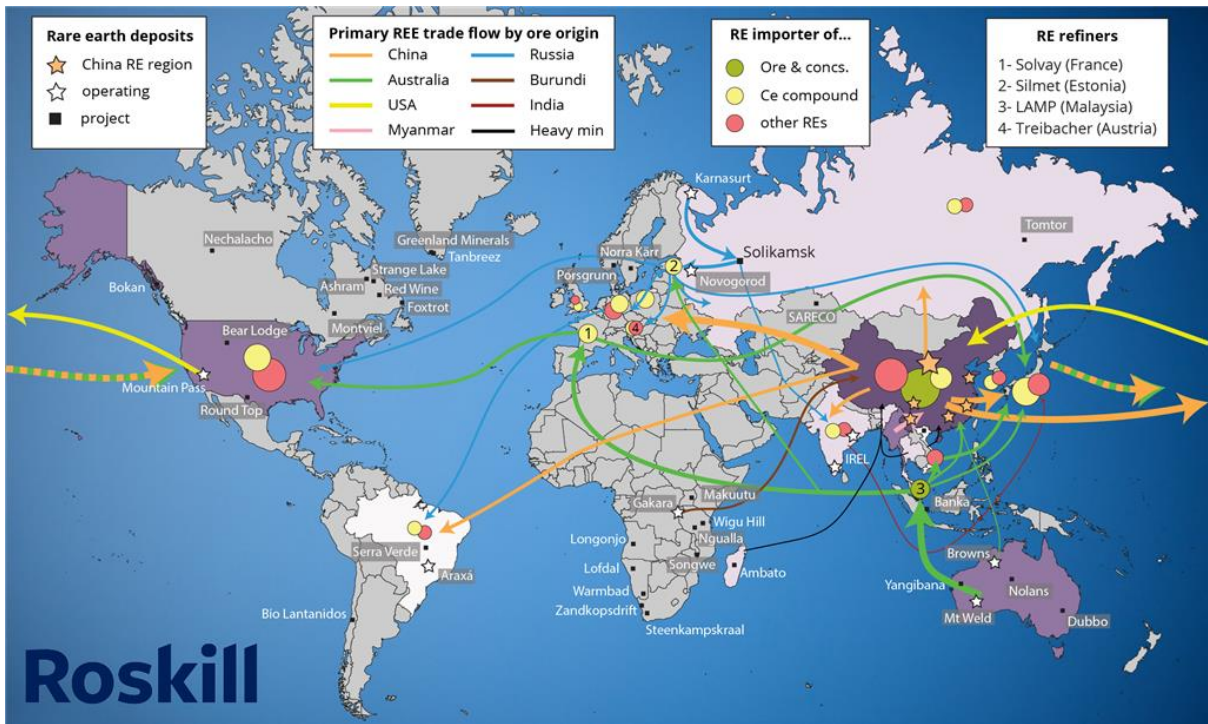
The most abundant and cheapest REE - lanthanum and cerium are used in catalysts (both fluid catalytic cracking and car catalysts) and in glass. Glass is also the main application of erbium and holmium/lutetium/ytterbium/thulium; and ceramics of yttrium.

Most of REE applications lack material substitutes with comparable cost and technical performance. However, for economic reasons, industry focuses on reducing the amount of REE used in many different applications or on changing to REE-free technology where possible.

Rare earths are mostly traded as Rare earth oxides (REO), metals or alloys. REE are not yet commodities, but customer specific chemicals, produced to precise chemical and physical specifications. Demand for REE has been steadily growing in average around 4% per year since 1975 (Kingsnorth 2018), since 2012 it has grown by 5.9% per year, recovering from suppressed demand following the 2011 price spike (Roskill 2019). Consumption of rare earths is estimated to reach 139.6kt REO in 2019. This creates a pressure on this small and highly specialised market of REE.

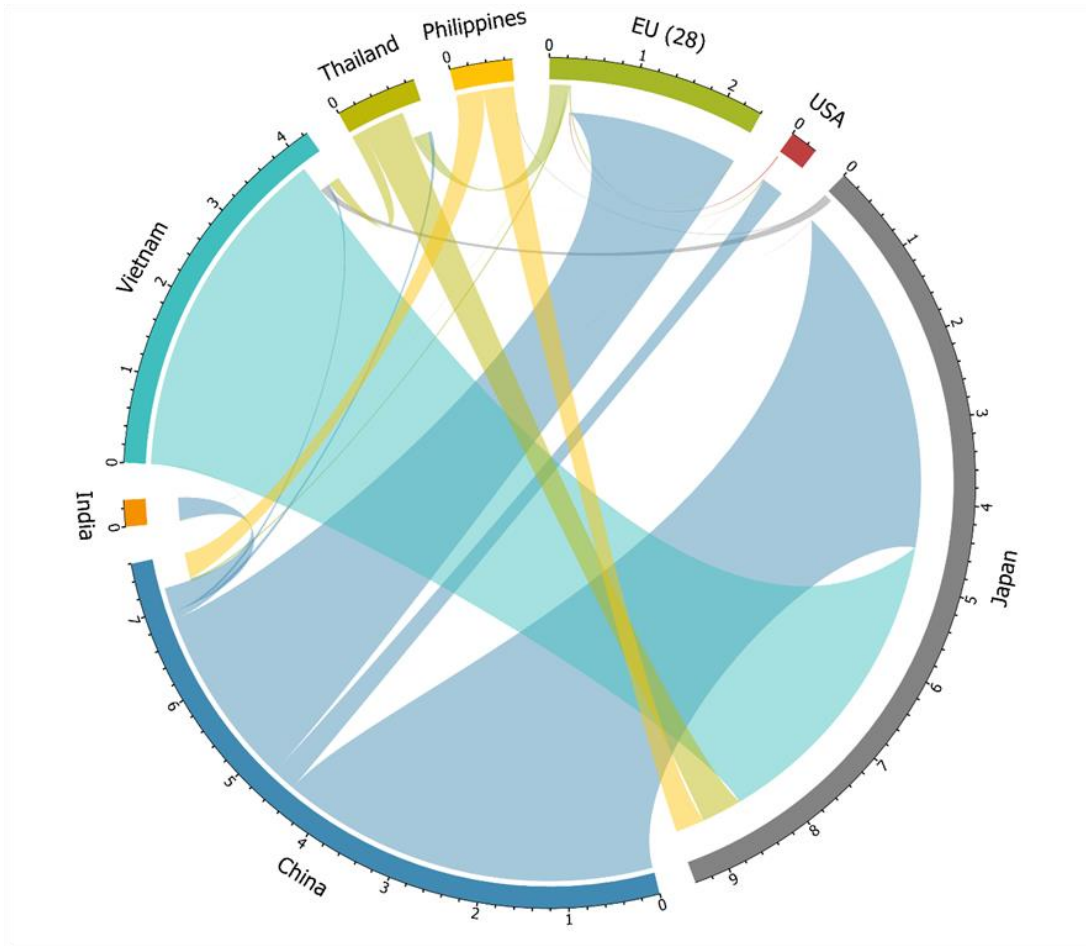
According to Roskill (2019), the USA was a key exporter of REE metals between 2000 and 2013, mostly related to reprocessed metals imported from China. Since 2014, exports fell below 200t and are expected to fall below 100t in 2018. Vietnam has become the second largest producer and exporter, reaching 4.000t in 2018. REE metals from Vietnam have a much higher value of close to US\$40/kg, reflecting Nd-Pr and other heavy rare earth metal products (i.e. not of cerium and lanthanum). Thailand exports higher value metals (averaging over US\$50/kg since 2017), while sources feeds from Malaysia, Japan, China and Estonia. Philippines exports are low, likely representing scrap products exported to Japan. Japan exports small volumes of metal, but typically of much higher value, with annual average unit values between US\$80-105/kg since 2016. Exports from Netherlands, Spain, Austria, USA and Belgium reflect re-exported trade.



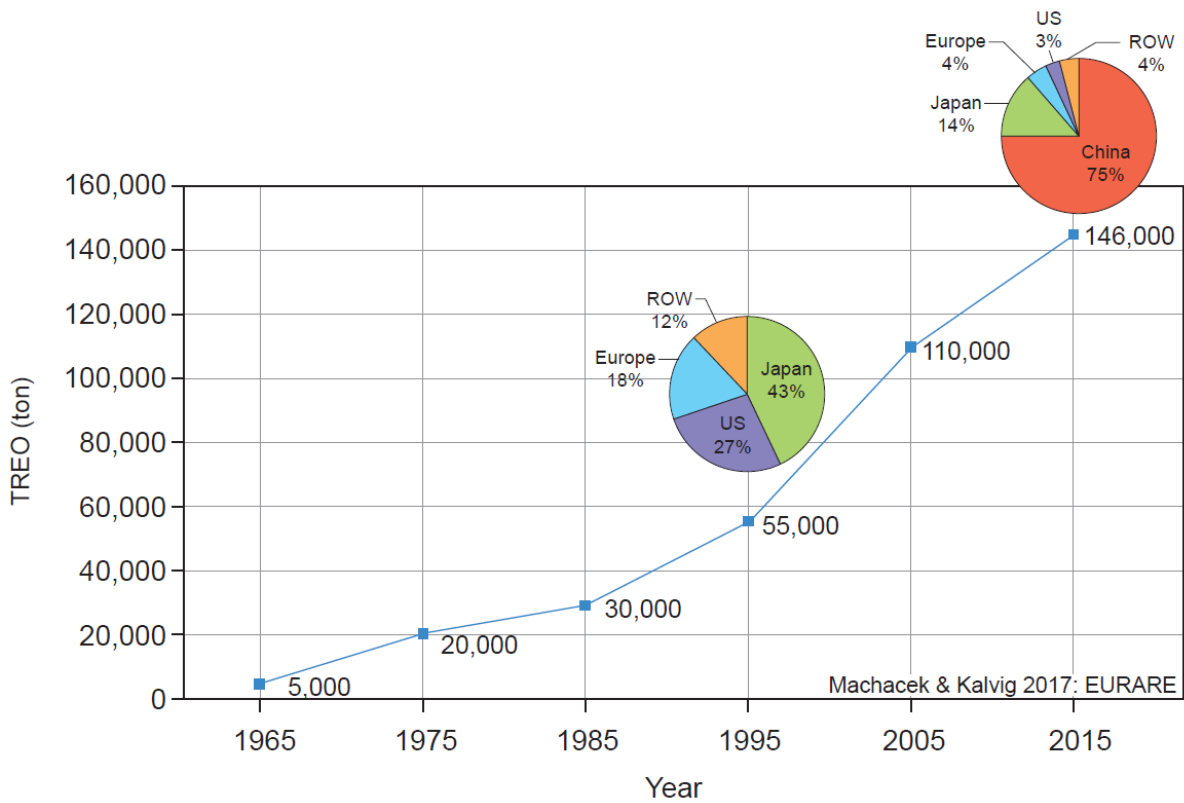


**Figure 328: World map of rare earth deposits, production and trade flow, 2019. (Roskill 2019)**

According to Roskill (2019), Norway, India, USA, Thailand, Germany and France are consistent importers of rare earth metals. The unit value for Japanese and Thai imports are the highest unit value importers at US\$29/kg and US\$36/kg, respectively, and probably reflect imports from magnet manufacturing facilities. USA and Germany import rare earth metals with an average unit value of around US\$10-12/kg.

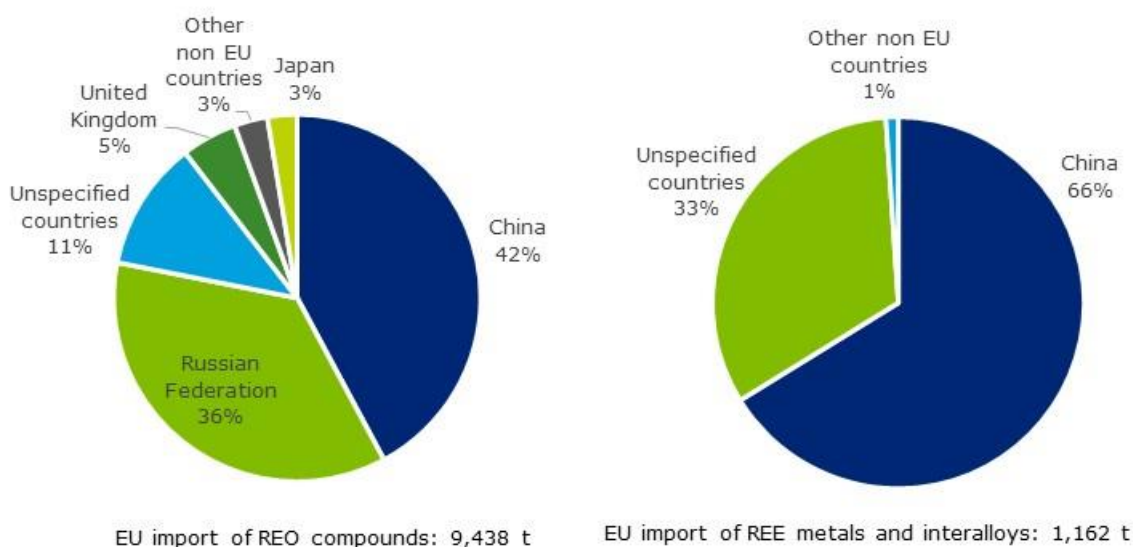


**Figure 329: Rare Earths metal trade flows in 2018 in gross kt. (Roskill 2019)**



**Figure 330: Long-term evolution of REE consumption REE (Machacek and Kalvig, 2017: EURARE)**

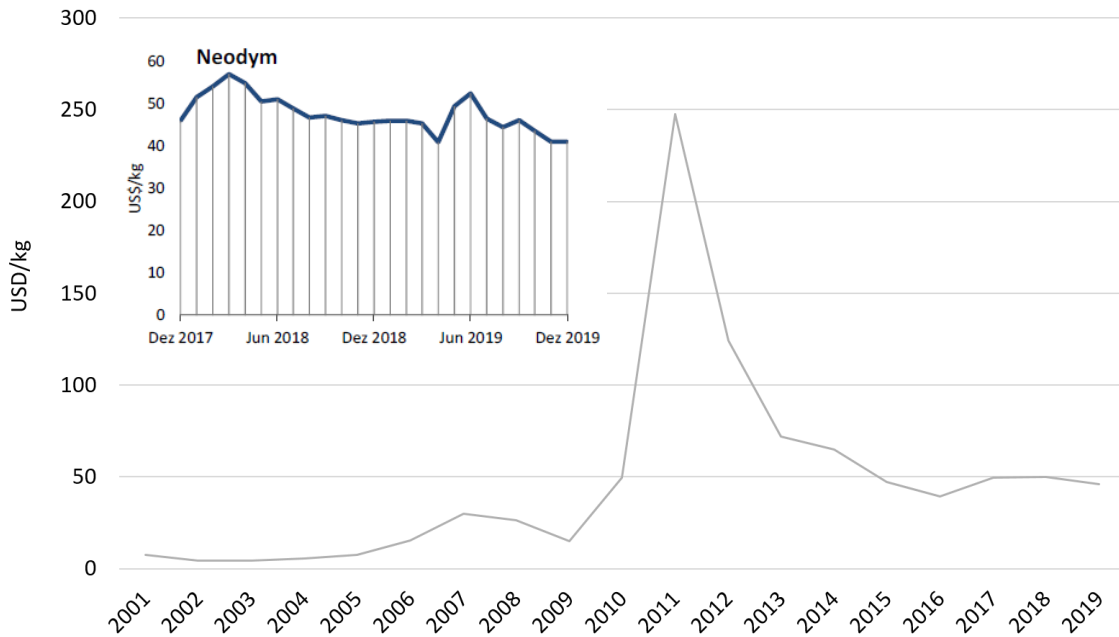
The EU is entirely dependent on imports of REE for its consumption. The average EU imports during the 2016-2018 period were 9,438 tonnes of REE compounds, 1,162 tonnes of REE metals and interalloys, while the EU exports were 5,464 tonnes of REE compounds and 601 tonnes of REE metals and alloys.



**Figure 331: EU imports of REE compounds (CN8 2846-1000, -9010 and -9020) and REE metals and interalloys (CN8 2805-3010, -3020, -3030) (Eurostat Comext, 2019).**

The EU imports 9,438 tonnes of REO compounds mainly from China (42%) and Russian Federation (36%). However, the significant share of Russian Federation is due to the import of Cerium compounds (64% of the total import of Ce oxide in EU). The EU imports HREE mainly from China, but also from Japan (18%), UK (6%) and Russian Federation (5%). EU import of 1,162 tonnes of REE metals and interalloys come from China (66%) and a not negligible share (33%) is reported under the label "Unspecified countries" and probably related to the Chinese market.

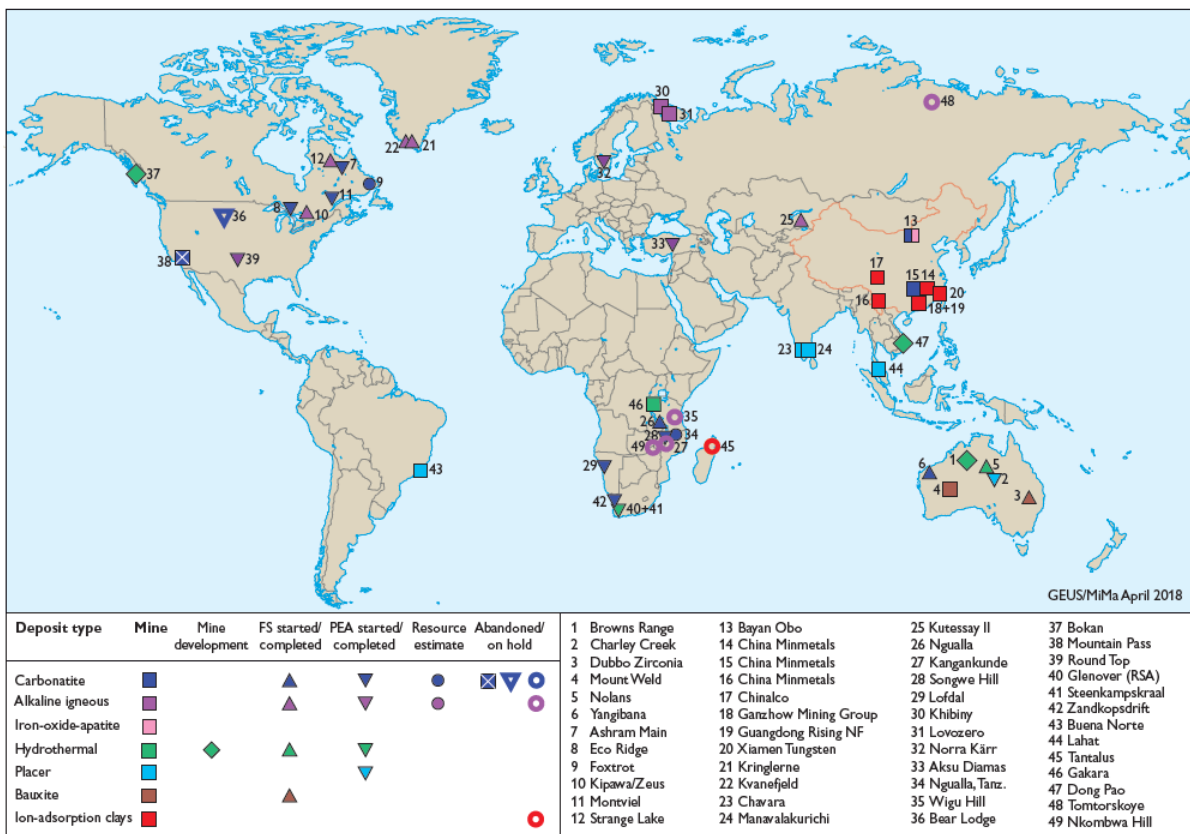
Prices of REE experienced great variations in the last decade, as shown on an example of neodymium (Figure 332). In 2010-2011 a 12-fold increase was observed, mainly triggered by a strong reduction of Chinese export quotas and geopolitical tension in a period of high demand for permanent magnets, driven by the expected growth of the renewable energy and electric vehicles markets. The highest price changes were observed for europium, most expensive REE for 15 years, but now taken over by terbium. Europium price increased from 785 USD/kg in 2002-2003 to an all-time high of USD 6,800 per kg in July 2011, then continuously decreasing to USD 35 USD/kg in 2019 (DERA 2019). From early 2012, prices were already down from half and went down almost continuously until 2019. An important exception is dysprosium, which price slightly increased in the last two years.



**Figure 332: Annual average prices of 99% neodymium oxide in USD/kg from 2001 to 2019 (FOB China, DERA 2019, 2020)**

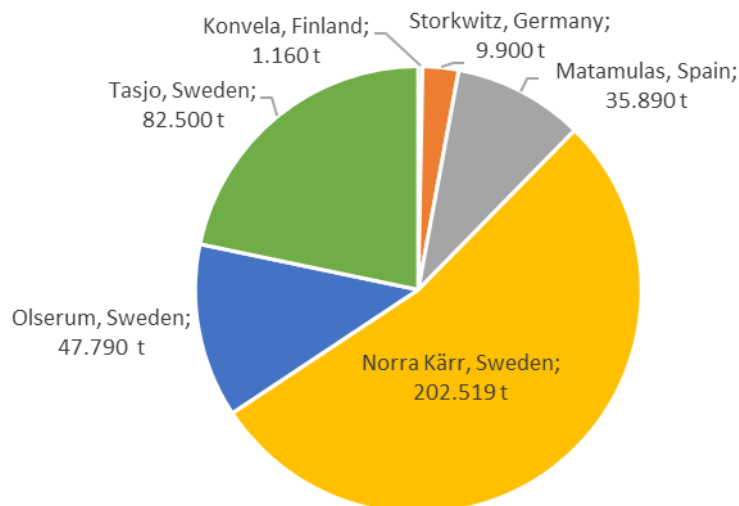
The feasibility of REE production depends on the geology, tonnage and grade of REE resources, available processing technologies, production costs and commodity prices.

Reserves of REE estimated by the USGS 2019 were around 120 million tonnes REO. BRGM (2015) estimates are more conservative and amount to 80 million tonnes REO. Largest resources are identified in China, Brazil, Vietnam, Russia, India, Australia, USA, Tanzania, Canada, South Africa, Malaysia and Greenland. Projects on REE are at different stages in the world, with the majority still developed in China, followed by India, Australia, US, Russia. A few projects at construction level in RSA and Kazakhstan, feasibility studies in other countries, including Canada.



**Figure 333: Major REE mining and advanced REE-exploration projects. (GEUS/MiMa, 2018)(Machacek and Kalvig, 2017: EURARE)**

In the EU, there are several potentially commercial projects classified under UNFC (E2; F2; G1,2,3) in Sweden (333,000 tonnes REO); Spain (36,000 tonnes REO) and Germany (10,000 tonnes REO).



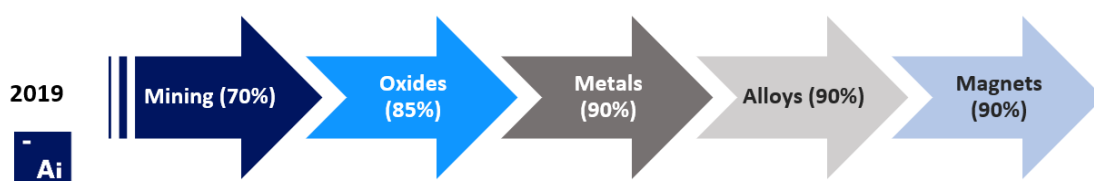
**Figure 334: Potentially commercial projects of rare earths in the EU with estimated quantities in tonnes of REO content classified according to UNFC - E2; F2; G1,2,3<sup>221</sup>. (EU Member States survey 2019)**

<sup>221</sup> see United Nations Framework Classification (ECE ENERGY SERIES No. 42): <https://www.unece.org/energy/welcome/areas-of-work/unfc-and-sustainable-resource-management/publications/unfc-and-resource-classification/2013/united-nations-framework-classification-ece-energy-series-no-42/docs.html> )

Europe has several potentially economic and other deposits (Norra Kärr, Grängesberg, Olserum and Tasjoin Sweden; Matamulas and Gemas, Tesorillo in Spain, Kvanefjeld and Kringlerne in Greenland; Fen, Kodal and Misværdalen in Norway; and Kontioaho, Korsnas and Konvela in Finland; and Vale de Cavalos in Portugal), but there is no REE mining operation in the EU.

Global mine production of REO equivalent in 2019 reached 210,000 tonnes according to USGS (2020). There are several active mines globally, but the information and statistics vary significantly.

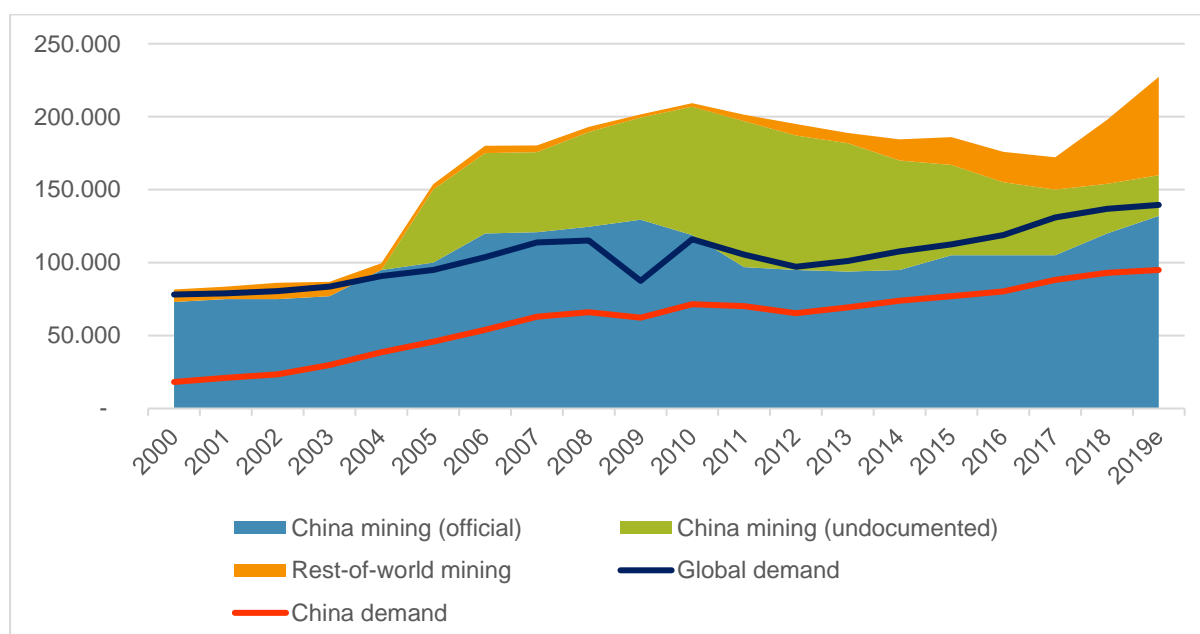
In recent years, China's share of global rare earth mine production has fallen slightly. However, China's share of downstream value-adding capacity to convert rare earth mine outputs in oxides, metals, alloys and magnets has continuously expanded. (Adamas Intelligence, 2019)



Source: Adamas Intelligence

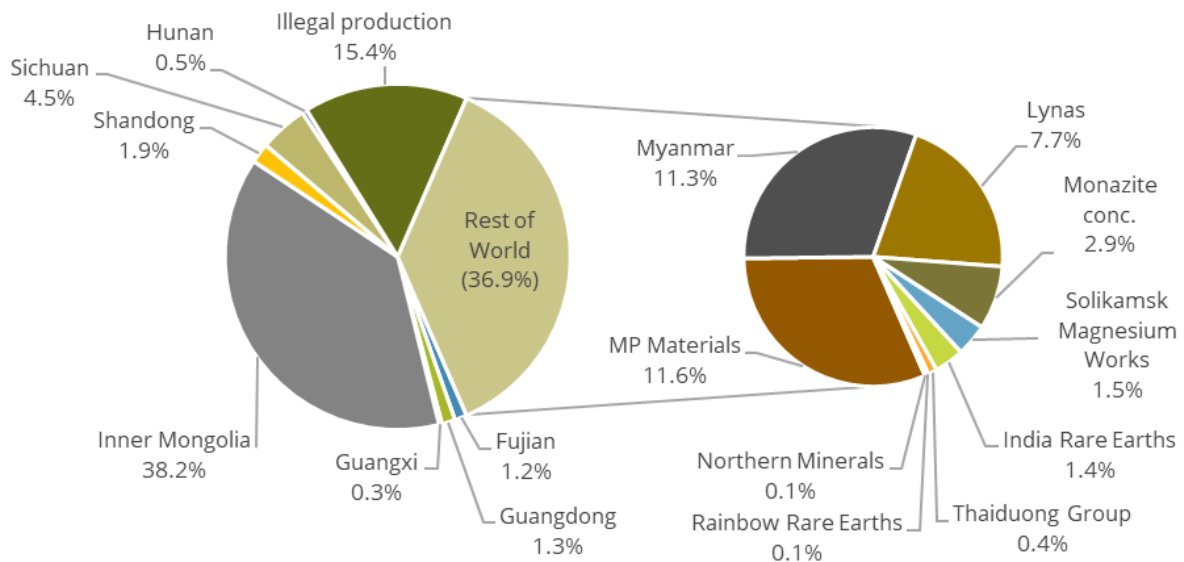
**Figure 335: Share of Chinese production in rare earths value chain (Adamas Intelligence, 2019)**

China, producing around 70-90% of the world REE production, controls the world market through production controls, export restrictions (e.g. quotas, tariffs), mine closings and company consolidation. All these factors contributed to unstable supply, significant price increases and volatility on the world market. China's official production quota increased to 132,000 tonnes in 2019 from 120,000 tonnes in 2018, 105,000 tonnes in 2014-17, while undocumented annual production over last years was estimated at 60,000-80,000 tonnes (Kingsnorth, 2018). According to ACREI (2019), the production capacity of the six Chinese rare earth producers was 227,000 tonnes in 2018, while the capacity of the whole industry including comprehensive recycling of rare earth resources was estimated to be about 300,000 tonnes.



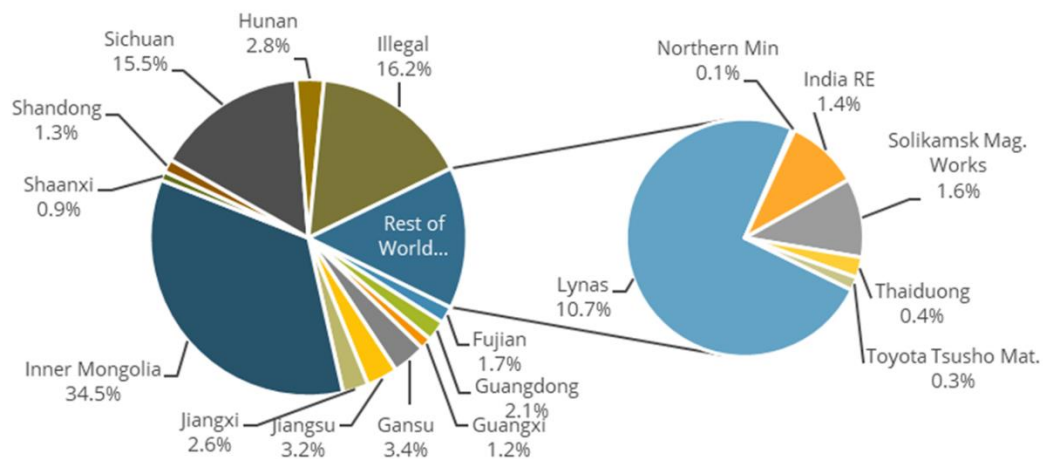
**Figure 336: Rare earths mine supply and demand 2000-2019 (WMD 2020, Roskill 2019)**

After a break in 2015-2017, US restarted mining in Mountain Pass reaching 18,000 tons in 2018, and 26,000 t in 2019 (USGS, 2020). But their ores and concentrates are shipped to China for refining, from where it sources 80% refined rare earths. In 2019, Australia mined 21,000 tonnes of REO, Myanmar 22000 tonnes, India 3000 tonnes, Russia 2,700 tonnes and Madagascar 2,000 tonnes and Thailand 1,800 tonnes. Brazil, Burundi, Malaysia, Vietnam and other countries produced 1000 tonnes or less (USGS, 2020).



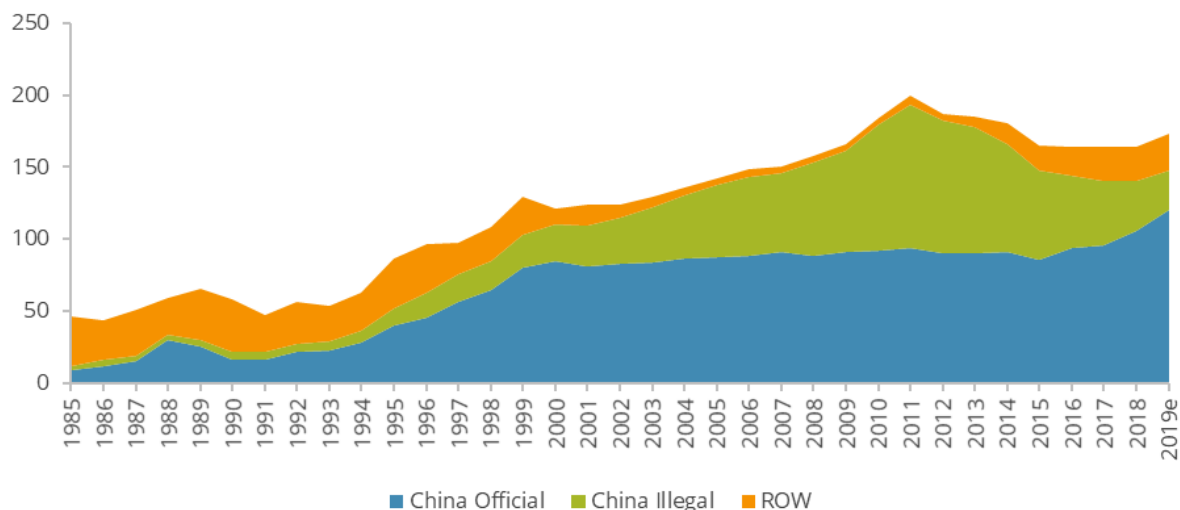
**Figure 337: World mine production of rare earths by company/Chinese province in 2019 (Roskill 2019)**

Over the last decade the EU substantially decreased the REE processing and refining capacity, but still has several companies producing different REE product, including NPM-Silmet operation in Estonia and Solvay REE operation in La Rochelle, FR Nevertheless, LKAB in Sweden develops a process to start a small REE production from the iron ore mining waste. Yara in Norway, currently develop processes to start a small rare earths production from their phosphate mining wastes. Potential exists also in coal and aluminium ore mining wastes.



**Figure 338: World refined production of rare earths by company/Chinese province in 2019 (Roskill 2019)**

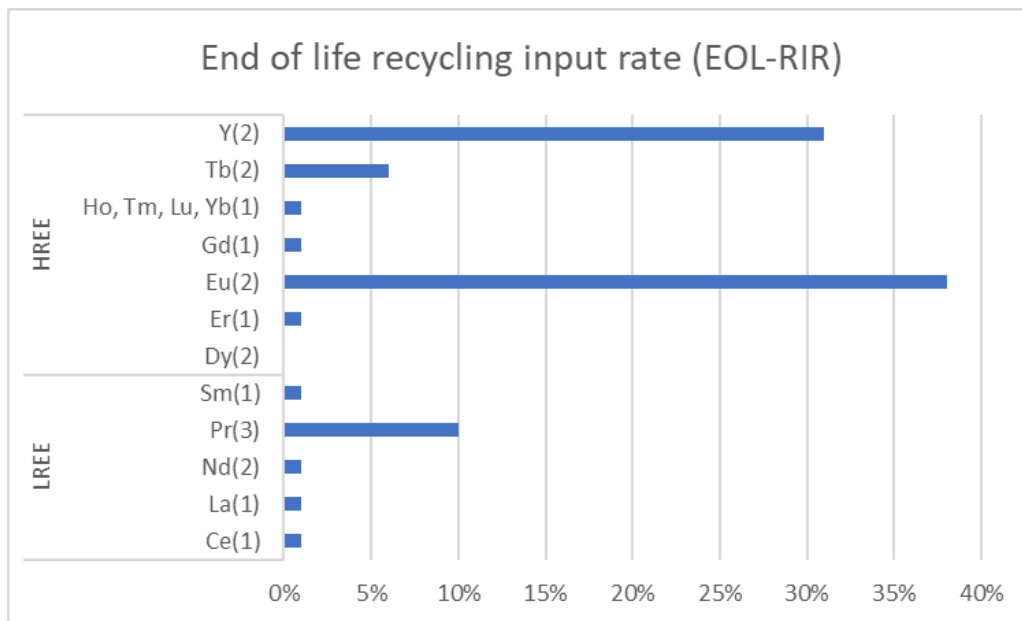
Global mine production of REE is forecast by Roskill (2019) to increase by 3.3%/py between 2019 and 2029, reaching a high of 252.0kt REO by the end of the forecast period. In the short term, additional Chinese official mine supply is expected to counteract the continued fall in illegal Chinese mine production. Illegal mine production is forecast to fall from 28.0kt REO in 2019 to 10.6kt REO in 2029, as the government crackdown and consolidation of the Chinese REE industry continues, although it should be noted that any forecast for illegal production is open to a range of unquantifiable variables.



**Figure 339: Global supply of refined rare earths during 1985-2019 in kt REO (Roskill 2019)**

The recycling input rates of REE are very limited, usually less than 1%. Even if technologies exist for reuse or recycling of individual REE, e.g. from magnets, industrial production is hampered in the EU. Main reasons are lack of efficient collecting systems and prohibitive costs of building REE recycling capacities, technology issues, products life time and changing chemistry or commercial viability. The processes required are energy intensive and complex. Higher recycling input rates for europium, yttrium and terbium are reported only thanks to recycling of fluorescent lamps, which are phasing out.





**Figure 340: End of life Recycling Input Rates of individual REE (1-UNEP, 2013; 2-Bio Intelligence Service, 2015; 3-BRGM, 2015)**

China is also a technology leader in REE refining, separation and recycling. China also host the ISO technical committee TC 298<sup>222</sup> on REE formed under the International Organization for Standardization in 2015. 11 ISO standards are under development in the fields of REE mining, concentration, extraction, separation and conversion to REE compounds (including oxides, salts, metals, master alloys, etc.), recycling, packaging, labelling, and REE traceability in the supply chain.

REE extraction and processing faces environmental and health and safety challenges, including handling of radioactive elements usually present in small quantities in the REE ores. At present, however, information regarding the environmental aspects of REE mining is limited. Toxicological data about the effects of REE on aquatic, animal, or human health are also limited (USGS 2017b). Recent studies (Werker et al., 2019) raise socio economic issues of social responsibility, fair competition and corruption connected with extraction of REE and magnets.

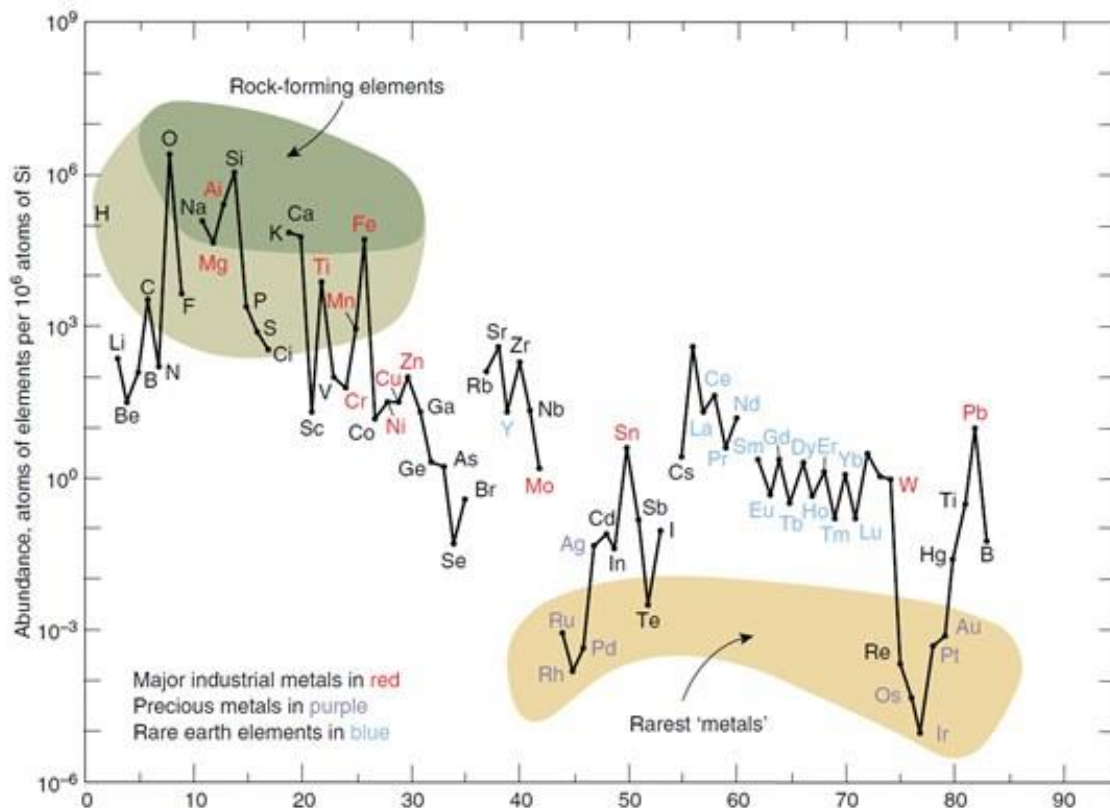
### 21.1.1 Individual rare earths

Rare Earth Elements (REE) are a group of 17 elements, comprising the elements scandium (Sc), yttrium (Y) and the 15 lanthanides (elements no. 57-71), as defined by the International Union of Pure and Applied Chemistry (IUPAC). For the purpose of the EU criticality assessment, radioactive promethium is not included and scandium is considered separately.

The term REE dates back to the discovery of the first unknown REE-minerals in Sweden in 1794; it took more than 150 years to identify all 17 elements. At the beginning of this period, the word "earth" referred to a metal oxide and not to soil. "Rare" at that time simply meant something strange or extraordinary. REE are relatively abundant in the upper part of Earth's crust, although with significant variations. The upper crust is assumed to contain 63 ppm of Ce and 33 ppm of La, which are the most abundant of the REE, to

<sup>222</sup> <https://www.iso.org/committee/5902483.html>

somewhat less than 0.3 ppm for Tm and Lu, the rarest of the REE (Weng et al. 2015). La and Ce are both more abundant than the average crustal concentrations of Cu (28 ppm) and Pb (17 ppm) (Rudnick and Gao, 2003). whilst the rarer HREE are still more abundant than gold, silver and platinum group elements (Rudnick and Gao, 2003). (Machacek and Kalvig 2017: EURARE)



**Figure 341: Abundance of chemical elements in the Earth's upper continental crust. (Haxel et al., 2002) (Machacek and Kalvig 2017: EURARE)**

“With a few exceptions, the REE are similar with respect to their ionic radii and oxidation states. This enables them to substitute for one another in crystalline structures, and is also the explanation for the occurrence of multiple REE within a single mineral (Castor and Hedrick, 2006). The most trivalent REE have similar ionic radii to Ca<sup>2+</sup>, Th<sup>4+</sup> and U<sup>4+</sup>, and thus the REE can and do replace some of these elements in a number of minerals. The REE are therefore commonly found in rocks which contain Ca, Th, U and Sr.

Physically, the REE have a number of unique properties that make them useful for a wide range of applications. For example, REE such as Gd, Dy, Er, Nd and Sm have ideal characteristics for magnet manufacturing; and Y and Tb provide sharply defined energy states which can be efficiently used in lighting and laser applications. The REE are frequently grouped, according to their atomic weight and properties into the two groups: the light REE (LREE) and the heavy REE (HREE). The definition of these two groups is varying among scientific disciplines.” (Machacek and Kalvig 2017: EURARE)

Some of the classifications are illustrated in Figure 342.

Element	Symbol	EURARE	IUPAC	China MLR		China State Council White Paper
				I	II	
Lanthanum	La	LREE	Unpaired electrons in 4f shells	LREE	LREE	LREE
Cerium	Ce					
Praseodymium	Pr					
Neodymium	Nd					
Samarium	Sm	HREE	Paired electrons in 4f shells	MREE	MREE	HREE
Europium	Eu					
Gadolinium	Gd					
Terbium	Tb					
Dysprosium	Dy					
Holmium	Ho					
Erbium	Er					
Thulium	Tm					
Ytterbium	Yb					
Lutetium	Lu					
Yttrium	Y	HREE				
Scandium	Sc					

**Figure 342: Classifications of REE elements in light REE (LREE) and heavy REE (HREE) (Machacek and Kalvig 2017: EURARE)**

#### 21.1.1.1 Cerium

Cerium (chemical symbol Ce) is considered as a light REE. Its upper crust abundance is 63 ppm (Rudnick, 2003). It is a silvery metal which tarnishes in air in a few days. It does not occur naturally as a metallic element and is found (for commercial exploitation) mainly in the minerals bastnäsite, loparite and monazite. Because of its chemical and optical properties and relative abundance it is found in many applications such as autocatalysts, glass and ceramics, polishing powders, fluid cracking catalysts (FCC), metallurgical alloys (mischmetal) and NiMH batteries (mischmetal).

#### 21.1.1.2 Dysprosium

Dysprosium (chemical symbol Dy) is considered as a heavy REE. Dysprosium's upper crust abundance is 3.9 ppm (Rudnick, 2003). It does not occur naturally as a metallic element and is found (for commercial exploitation) almost exclusively in the minerals xenotime and ion-adsorption clays (in Southern China). Dysprosium is a silvery very hard metal which slowly oxidizes in air (a few years). Its main and almost exclusive use is in permanent magnets NdFeB, where it improves resistance to demagnetization and high working temperature performance up to 200°C.

#### 21.1.1.3 Erbium

Erbium (chemical symbol Er) is considered as a heavy REE. Erbium's upper crust abundance is 2.3 ppm (Rudnick, 2003). It is a silvery hard metal, which slowly oxidizes in air (a few years). It is used mainly used in optical fibres, for glass colourising, dopant in lasers (also for 5G) and phosphors.

#### 21.1.1.4 Europium

Europium (chemical symbol Eu) is considered as a light REE. Its upper crust abundance is 1 ppm (Rudnick, 2003). It does not occur naturally as a metallic element and is found in minerals such as bastnäsite and monazite. It is a moderately hard, silvery metal which readily oxidizes in air and water. The main use of europium is in lighting and exploits the phosphorescence of europium compounds.

#### **21.1.1.5 Gadolinium**

Gadolinium (chemical symbol Gd) is considered as a heavy REE. Gadolinium's upper crust abundance is 4 ppm (Rudnick, 2003). It does not occur naturally as a metallic element and is found in minerals such as bastnäsite and monazite. Gadolinium is a silvery-white, malleable and ductile rare earth metal. Gadolinium metal possesses unusual metallurgical properties, to the extent that as little as 1% gadolinium can significantly improve the workability and resistance to high temperature oxidation of iron, chromium, and related alloys. Its main applications are permanent magnets, lighting and metallurgy. Gadolinium as a metal or salt has exceptionally high absorption of neutrons and therefore is used for shielding in neutron radiography and in nuclear reactors.

#### **21.1.1.6 Holmium, Lutetium, Ytterbium, Thulium**

Holmium (chemical symbol Ho), thulium (chemical symbol Tm), ytterbium (chemical symbol Yb) and lutetium (chemical symbol Lu) are all heavy rare earth elements. They are at the end of the lanthanide series, with a very low natural abundance and only few niche applications mostly related to their optical properties (Laser dopants, radiography, etc.).

#### **21.1.1.7 Lanthanum**

Lanthanum (chemical symbol La) is considered as a light REE. Its upper crust abundance is 31 ppm (Rudnick, 2003). Although it is classified as a rare earth element, lanthanum is the 28<sup>th</sup> most abundant element in the Earth's crust, almost three times as abundant as lead. It is the second most common of the lanthanides after cerium. In minerals such as monazite and bastnäsite, lanthanum composes about a quarter of the REE content. It is a silvery white metallic element. It tarnishes rapidly when exposed to air and is soft enough to be cut with a knife. Lanthanum compounds have numerous applications as fluid cracking catalysts, additives in glass and ceramics, as well as in mischmetal for batteries.

#### **21.1.1.8 Neodymium**

Neodymium (chemical symbol Nd) is considered as a light REE. Neodymium's upper crust abundance is 27 ppm which is more than cobalt (17.3 ppm) (Rudnick, 2003). It is one of the most abundant REE, together with lanthanum and cerium. It does not occur naturally as a metallic element and is mainly found (for commercial exploitation) in the minerals bastnäsite, monazite, and ion-adsorption clays. It is a soft silvery metal that tarnishes in air in a few days. Its most important use is in permanent magnets NdFeB. It is also valued for its chemical and optical properties in other applications such as metallurgical alloys, ceramics, or as a laser dopant (BRGM, 2015).

#### **21.1.1.9 Praseodymium**

Praseodymium (chemical symbol Pr) is considered as a light REE. Praseodymium's upper crust abundance is 7.1 ppm (Rudnick, 2003). It does not occur naturally as a metallic element and is found in minerals such as bastnäsite and monazite. It is a soft, silvery, malleable and ductile metal. It is valued for its magnetic, electrical, chemical, and optical properties. Its main uses are in permanent magnets NdFeB, batteries, ceramics, metallurgy, catalysts, polishing powders and glass.

#### **21.1.1.10 Samarium**

Samarium (chemical symbol Sm) is considered as a heavy REE. Its upper crust abundance is 4.7 ppm. Although classified as a rare earth element, samarium is the 40<sup>th</sup> most abundant element in the Earth's crust and is more common than such metals as tin. Samarium does not occur naturally as a metallic element, and is found in several minerals including cerite, gadolinite, samarskite, monazite and bastnäsite, the last two being the most common commercial sources of the element. Samarium is a moderately hard silvery

metal that readily oxidizes in air. Its main and almost exclusive use is in permanent magnets SmCo, and also niche applications mostly related to its optical properties (Laser dopant, radiography, etc.).

#### **21.1.1.11 Terbium**

Terbium (chemical symbol Tb) is considered as a heavy REE. Its upper crust abundance is 0.7 ppm (Rudnick, 2003). It does not occur naturally as a metallic element and is found mainly in the minerals xenotime, monazite and ion-adsorption clays (for commercial exploitation). It is a silvery very hard metal which slowly oxidizes in air (a few years). Most of the world's terbium supply is used in green phosphors. It is also important in permanent magnets, as a substitute for dysprosium

#### **21.1.1.12 Yttrium**

Yttrium (chemical symbol Y) is considered a heavy REE. Its upper crust abundance is 21 ppm which is more than cobalt (17.3 ppm) (Rudnick, 2003). It does not occur naturally as a metallic element and is mainly found (for commercial exploitation) in the minerals xenotime and ion-adsorption clays (in Southern China). Yttrium is a silvery metal with high thermodynamic affinity for oxygen. It is mainly used in various phosphors, for display screens and energy efficient lighting. It also has applications in ceramics and glass, metallurgical alloys, and various medical applications and tracing.

## 21.2 Market analysis, trade and prices

---

### 21.2.1 Global market analysis

REE are not yet commodities, but customer specific chemicals, produced to precise chemical and physical specifications. The REE market is a specialty market, characterized by business to business trade rather than exchanges on metal markets.

The global mine production and market of REE is estimated at 170,000t of rare-earth-oxide equivalent (REO<sup>223</sup>) in 2018, and 8.10 billion USD in 2018 (Zion Markey Research 2019). While Kingsnorth, 2018 estimates the world global market of rare earths in 2017 at about 170.000t of REO worth 3-5 billion USD. According to China's Ministry of Commerce, production of REO in China was estimated to be at least 180,000 tonnes based on magnet material production. China dominates the market with around 80-90% of the world production, including the official production quota of 120,000 tonnes for 2018 and undocumented production.

Roskill (2019) estimates REE annual demand growth of over 5% between 2014-2019, driven by the increased use of rare earth permanent magnets in automotive and renewable energy applications, supported by underlying demand growth in catalysts, ceramics and polishing powders.

Production of lanthanum and cerium oxides accounts for about 70%, praseodymium and neodymium oxides for around 20%, and other elements account for around 10%.

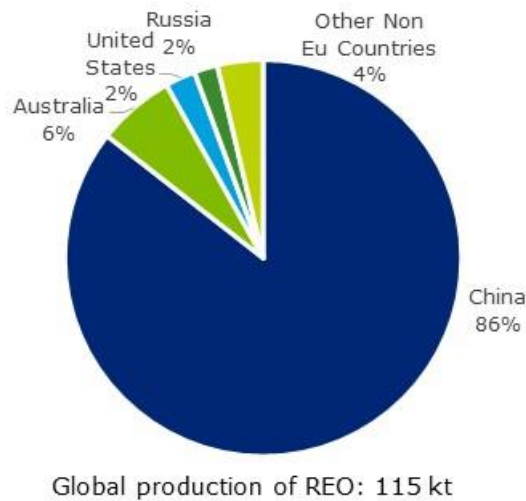
Issues with determining the market size and dynamics is limited by:

- the difficulty of obtaining estimates of the illegal share of production, i.e. the extent of the activities of grey miners;
- a limited understanding of the total production of REE-products in China (from mining to components) given that REE-production quota are official figures which are not representative of the total production;
- high price volatility;
- the volume and distribution of REE-stockpiles;
- difficulty with identification of types and quality of REE products (e.g. mixed rare earth carbonates, oxides or metals), further complicated by aggregated trade statistical codes for product groups;
- REE market imbalance, demand for neodymium, praseodymium, dysprosium and terbium used in magnets is high, while there is excess of lanthanum and cerium products.

According to the available data for 2012-2016 the average global consumption of REE was only 115.000 tonnes of REO. For comparison, the annual REO production is similar to cobalt - about 130,000 tonnes, while the annual production of the iron ore was around 1,5 billion tonnes (WMD 2019).

---

<sup>223</sup> Average conversion factor of REE metal vs. Rare Earth Oxides (REO) is estimated at 0.85 (Guyonnet, et al. 2015).

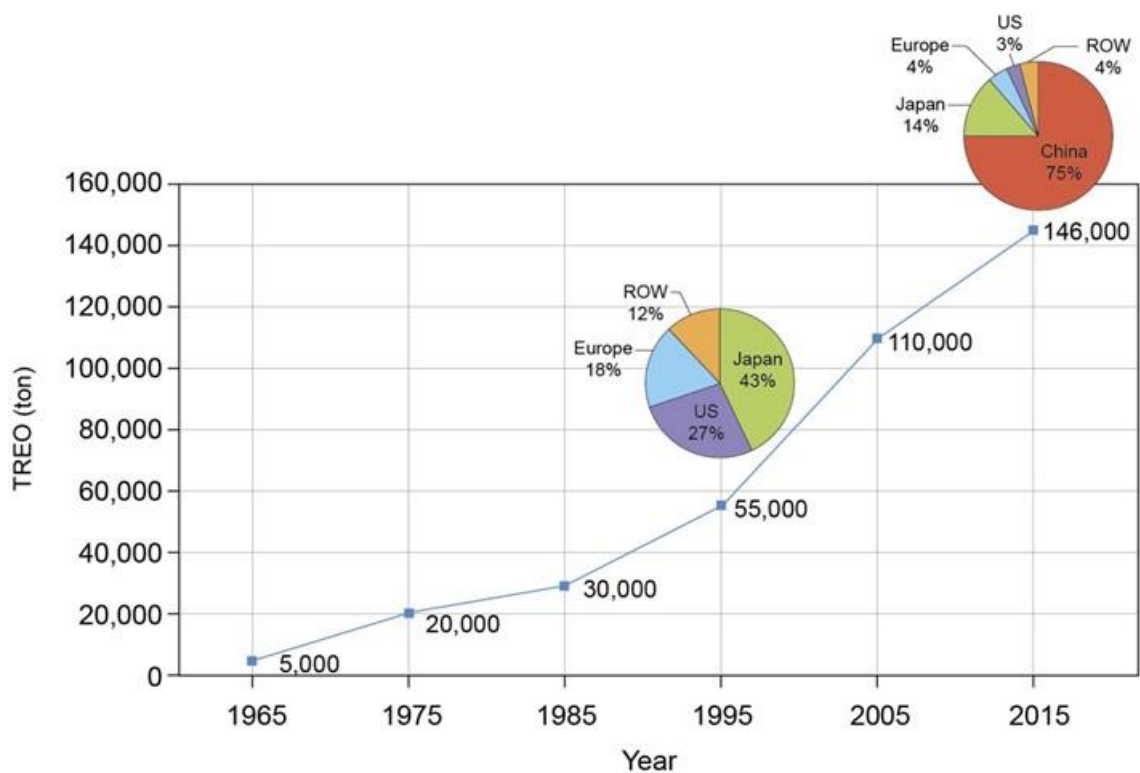


**Figure 343: Global production of REO, average 2012-2016 (WMD, 2019)**

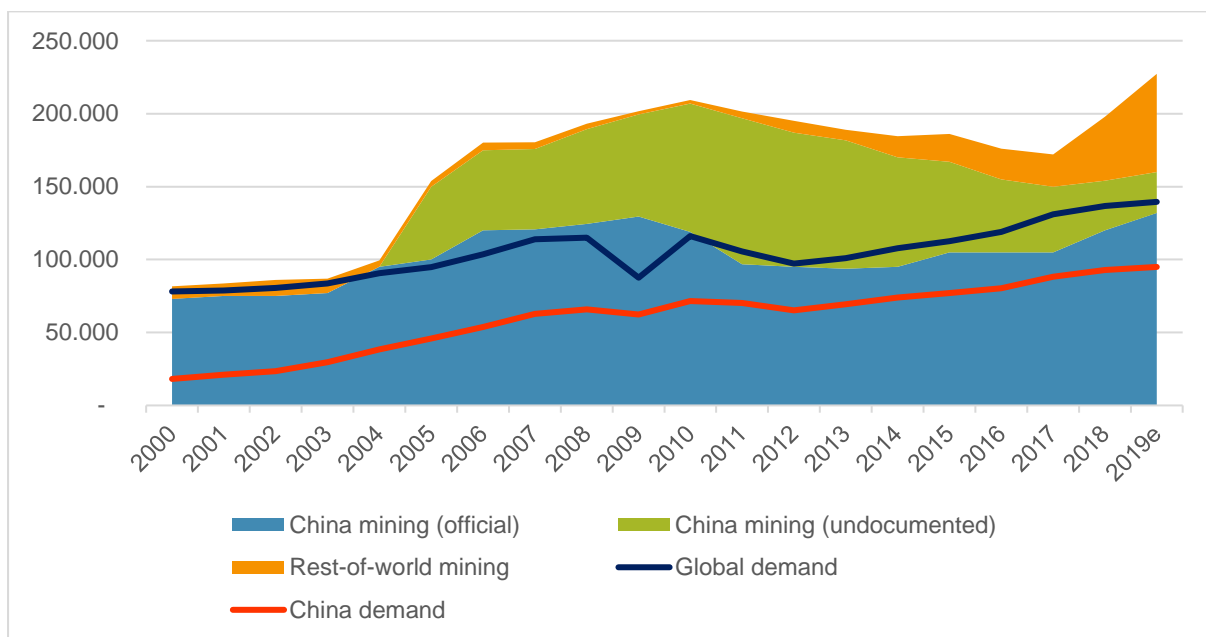
REE are mostly traded as rare earth oxides (REO), metals or alloys. Demand for REE has been steadily growing in average around 4% per year since 1975, slightly increasing in the last years (Kingsnorth 2018). This creates a pressure on this small and highly specialised market of REE.

**Error! Reference source not found.** illustrates the changes in the total rare earth demand from 1965 to 2015 per decade: In 1965, global demand amounted to about 5,000 tonnes REO, while in 2015 it was estimated at approximately 145,000-150,000 tonnes REO. Importantly, **Error! Reference source not found.** shows the significant shift in regional demand patterns: In 1995, Japan accounted for about 43% of global demand, the USA for about 27%, Europe for 18% and the ROW for 12%. (Machacek and Kalvig 2017: EURARE)

In the two decades since 1995, the demand for REE metals (as opposed to REE-containing final consumer products) in China surged significantly to account for approximately 75% of global demand. Demand of REE metals in Japan reduced to 14%, followed by Europe and the ROW with about 4% and the USA with 3%. REE metals demand of China surpassed that of Japan, and it rose to account for three quarters of global demand over two decades only.



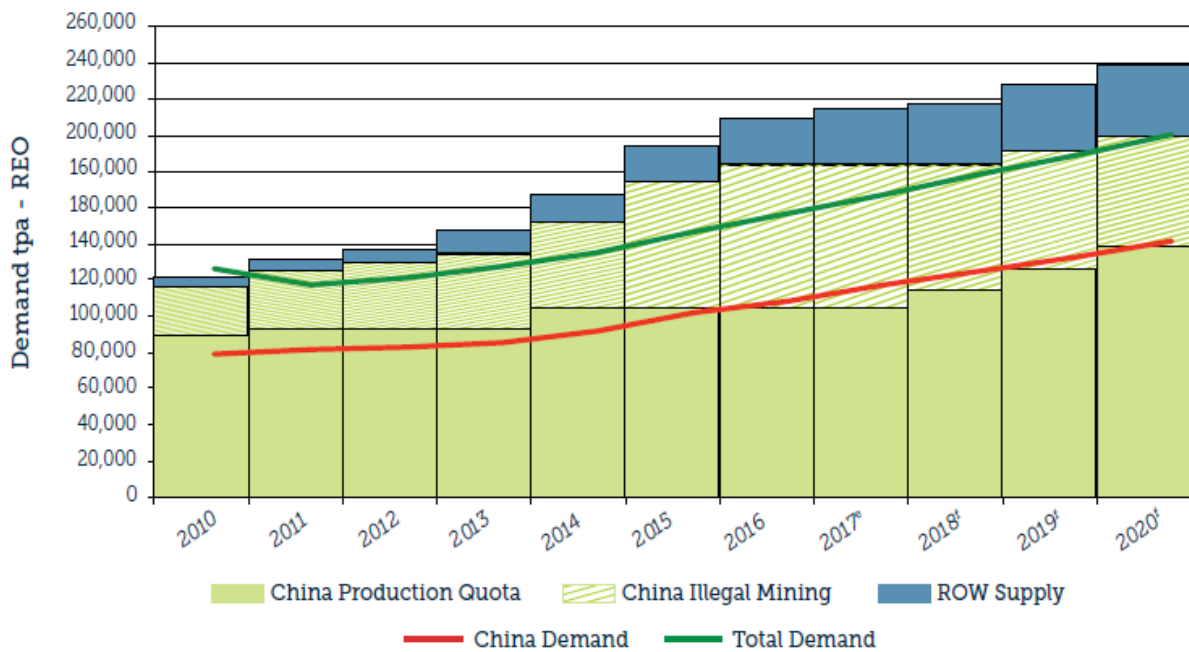
**Figure 344: Changes in total rare earth demand during 1965-2015 (t REO). (Machacek and Kalvig 2017: EURARE)**



**Figure 345: Rare earths mine supply and demand 2000-2019 (WMD 2020, Roskill 2019)**

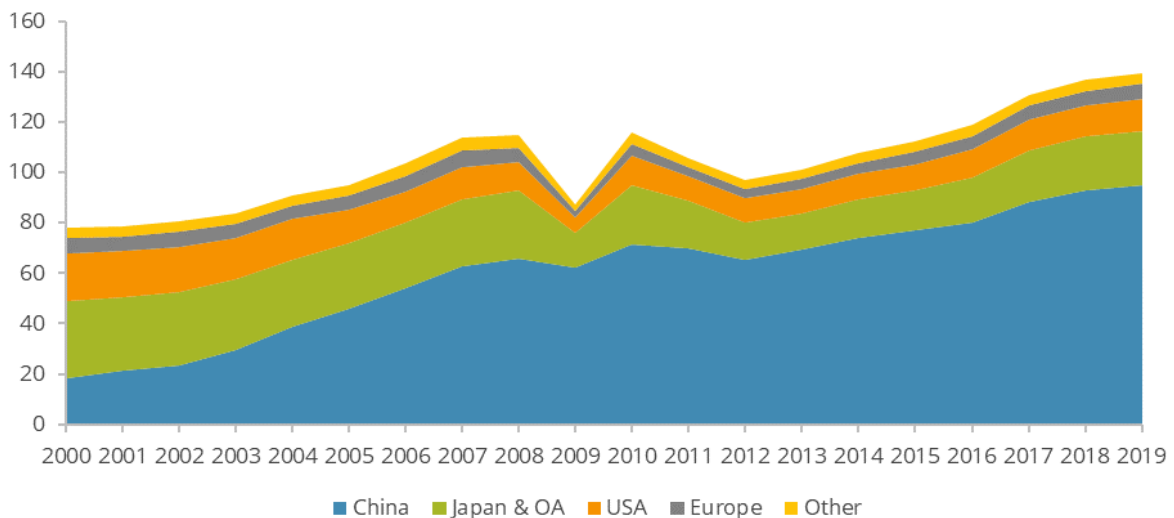
For comparison, slightly different picture with more moderate estimate of undocumented mining is shown for the period 2010-2020 by Kingsnorth (2018).





**Figure 346: Rare Earths mining supply and demand 2010-2020. (Kingsnorth, 2018)**

China’s position as a reliable low-cost supplier of raw materials for manufacturing deteriorated as its market share and domestic consumption grew and a combination of production controls, export restrictions (e.g. quotas, tariffs), mine closings, and company consolidation contributed to significant price increases and volatility on the world market.



**Figure 347: Global consumption of rare earths by region in 2000-2019 in tonnes REO (Roskill 2019)**

The negative effects on competitiveness of non-Chinese manufacturers led China’s trading partners to bring a series of complaints before the World Trade Organization (WTO)<sup>224</sup>, beginning in 2009 and culminating in May 2015 with China’s removal of export restrictions on rare earths, tungsten, and molybdenum.

<sup>224</sup> WTO, *China—Measures Related to the Exportation of Various Raw Materials*, Dispute Settlement DS394, January 28, 2013; WTO, *China—Measures Related to the Exportation of Rare Earths, Tungsten and Molybdenum*, Dispute Settlement DS431, DS432, DS433, May 20, 2015.

In 2009, the United States and the European Union (EU) brought a complaint against China's trade restrictions on various forms of bauxite, coke, fluorspar, magnesium, manganese, silicon carbide, silicon metal, yellow phosphorus, and zinc. When the WTO ruled in favour of the United States and the EU, China appealed and lost, then took full advantage of the "reasonable period of time" allowed under WTO rules before finally removing export duties on these materials on 1 January 2013, the very day the time for compliance expired.

In the meantime, between 2010 and 2013 prices of some rare earth metals spiked by thousands of percent and exploration activities boomed all over the world. However, even though many deposits were identified, almost none of those projects reached the production stage.

In 2012, just after the peak of prices in 2011, the United States, EU, and Japan brought an additional complaint against China's trade restrictions on rare earths, tungsten, and molybdenum. This dispute was also settled in favor of the United States, EU, and Japan. China appealed again and lost, and finally removed export duties and export quotas, as well as restrictions on trading rights of enterprises exporting rare earths and molybdenum. China again acted on the last day, in this case, 2 May 2015.

However, price volatility and instability of market have halted several perspective projects worldwide and contributed to the collapse of Molycorp - the major US producer in 2015.

A policy document on rare earths released in October 2016 by Chinese ministry of industry and information technology summarizes what China plans to do with the industry in coming years. The document advocates more state intervention to tackle internal problems such as illegal rare earth production, illegal transaction and processing, lack of innovation, overcapacity problems in upstream sectors and poor legal and regulatory systems to address environmental pollution (MIIT, 2016).

The Chinese government's objectives on REE development is summarized in the table below.

**Table 144: The development of the rare earth industry main target during the "13th Five-Year Plan"**

Indicators	Actual in 2015	Targets by 2020	Cumulative percentage change during "13th five-year"
<b>1. Economic Indicators</b>			
Average annual growth rate of industrial added value ( % )	12.5	16.5	—
Industry profit margins ( % )	5.8	12	[6.2]
R & D expenditure of key enterprises accounted for the proportion of the main income ( % )	3	5	[2]
<b>2. Production Indicators</b>			
Smelting separation capacity (Million tons)	30	20	[-10]
Production of rare earth smelting and separation products (Million tons)	10	< 14	[<4]
Recovery rate of mineral processing of light rare earth ore ( % )	75	80	[5]
Comprehensive recovery rate of recovery of ion type rare earth ore (%)	75	85	[10]
Light rare earth smelting separation recovery rate ( % )	90	92	[2]

Indicators	Actual in 2015	Targets by 2020	Cumulative percentage change during "13th five-year"
Ion type rare earth smelting separation recovery rate ( % )	94	96	[2]
The integration of the two standards of Enterprise Accounting (%)	30	90	[60]
<b>3. Green Development Indicators</b>			
Reduction of major pollutants emission intensity in the whole industry (Containing sulphur dioxide, ammonia nitrogen, waste water, etc., % )	—	—	[20]
Proportion of enterprise achieving energy consumption standard (%)	40	90	[50]
<b>4. Application Industry Development Indicators</b>			
Market share of high-end rare earth functional materials and devices ( % )	25	50	[25]
Proportion of primary raw materials on export products ( % )	57	30	[-27]

Inside the brackets [ ] are cumulative numbers for five years. Source: MIIT 2016, Rare Earth Industry Development Plan (2016-2020) (translated from Chinese).

## 21.2.2 Future market for REE

COVID-19 crisis has impacted global economy, the rare earths products market is expected to decrease in 2020, but should increase again in 2021. Fast growing electric vehicles production, from couple of million cars today to 30 million in 2030, should stay a dominant application of REE, though the proportion of REE permanent magnets technology should decrease from 90% to 70-80% in 2030.

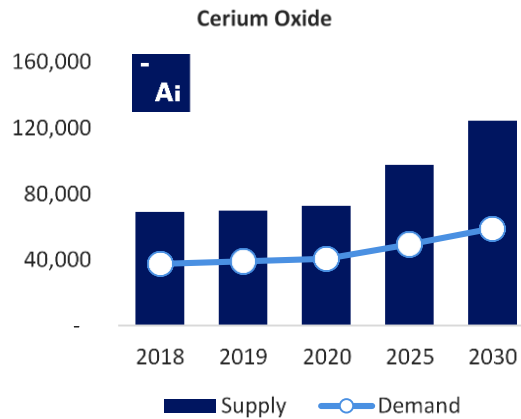
Adamas predicts 11% decrease in 2020 and then growth of 8% per year until 2030 reaching 150% more demand than today. Kingsnorth (2018) expects the REE demand to grow 6-7% per year by 2025. Roskill (2019) forecasts only 3.3% annual growth by 2024 and slowing to 2.1% annually between 2024 and 2029. Roskill expects that permanent magnet growth slows and battery demand declines by 6.8% per year, while lanthanum NiMH batteries will continue to lose market share to lithium-ion batteries.

By 2025, rare earth magnets are forecast to exceed a third of total demand, changing the focus of rare earth producers and processors. The changing emphasis towards rare earth magnet raw materials is expected to impact rare earth pricing mechanisms, with operations becoming increasingly dependent economically on a small number of individual rare earths.<sup>225</sup>

<sup>225</sup> <https://roskill.com/market-report/rare-earths/>. Accessed on 14 February 2020

### 21.2.2.1 Cerium

The overall demand for cerium is expected to increase by around 6% per year (Rare Earth Investment News, 2016). However, as for lanthanum, supply is expected to more than keep up, moving the market into an increasing surplus. Roskill (2019) expects more than doubling surplus by the mid-2020s and, by 2029, reaching a surplus of 31.0kt of cerium oxide.



**Figure 348: Global annual supply of cerium is expected to continue exceeding global annual demand by 2030 (Adamas Intelligence, 2019b)**

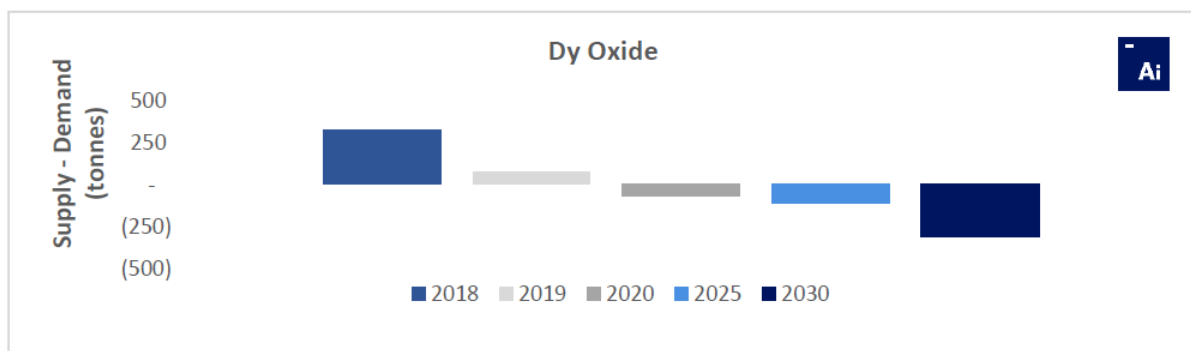
### 21.2.2.2 Dysprosium

The future evolution of dysprosium demand is driven by two forces:

- The anticipated growth of the permanent magnet market for the manufacture of wind turbines and electric vehicles. Those applications are supported by green energy and green transportation initiatives which are likely to incentivise a growth of their production (Rare Earth Investing News, 2016). Globally, the rapid increase of the demand for air conditioning by Indian and other South-East Asian customers could also play in the expected growth of the permanent magnets market (Powder Metallurgy Review, 2016). As a result of those factors, the demand of Dy-containing magnets is expected to increase;
- Efforts to reduce the content of dysprosium in NdFeB magnets: Adamas expects the content of dysprosium in magnets to drop from 2.3% in 2014 to 1.9% in 2020 (Guyonnet et al., 2015).

Adamas Intelligence (2019) forecasts that global annual demand for dysprosium oxide (or oxide equivalent) will increasingly exceed global annual production between 2020-2030, resulting in the depletion of historically-accumulated inventories and, ultimately, shortages of dysprosium if global production is not increased beyond what is currently forecasted.

Specifically, by 2030, Adamas Intelligence forecasts that global demand for dysprosium oxide (or oxide equivalent) will exceed global annual production by upwards of 300 tonnes – equal to the amount of material needed for production of approximately 3.0 million electric vehicles traction motors.



**Figure 349: Global annual demand of dysprosium to exceed global annual production by 300 tonnes in 2030 (Adamas Intelligence 2019)**

### **21.2.2.3 Erbium**

The overall demand for erbium is expected to increase by around 6% per year until 2020 (EC, 2014).

### **21.2.2.4 Europium**

The demand of europium is likely to drop considerably in the future (Guyonnet et al., 2015). The future decrease of europium demand is directly linked to the significant reduction (at least 65%) of rare earth needs for the lighting industry between 2015 and 2030 (Guyonnet et al., 2015).

This evolution is due to the changes in the lighting market structure and is driven by two forces:

- The anticipated decrease of the fluorescent lamps market face to the growing new technology LEDs (Mc Kinsey, 2012): in the lighting market as a whole, LED lighting penetration is projected to be around 40% in 2016 and over 60% in 2020 (Mc Kinsey, 2012).
- The content of rare earths (including Eu) in LEDs is much lower than in fluorescent lamps (1,000 times lower) (Guyonnet et al., 2015).
- As the lifetime of LED is 40,000-50,000 hours, compared to 10,000-25,000 hours for fluorescent lamps, the decrease in rare earth need for the lighting sector will amplify in the coming years (Guyonnet et al., 2015).

### **21.2.2.5 Gadolinium**

The overall demand for gadolinium is expected to increase by around 9% per year until 2020 relating to uses in magnets (linked to a possible growth in magnetic refrigeration) and in medical imagery (EC, 2014).

### **21.2.2.6 Holmium, Lutetium, Ytterbium, Thulium**

The overall supply and demand for Ho-Tm-Yb-Lu supply is expected to increase by around 8% per year until 2020 (EC, 2014).

### **21.2.2.7 Lanthanum**

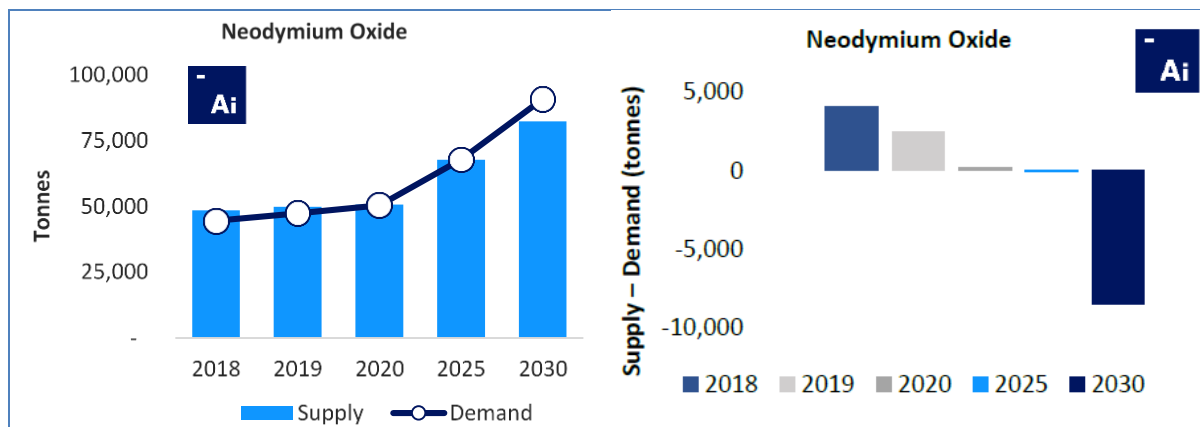
The supply of lanthanum is expected to more than keep up, moving the market into an increasing surplus. Roskill (2019) expects more than doubling surplus by the mid-2020s and, by 2029, reaching a surplus of 25.3kt of lanthanum oxide.

### **21.2.2.8 Neodymium and Praseodymium**

The future evolution of neodymium and praseodymium demand is driven by two forces:

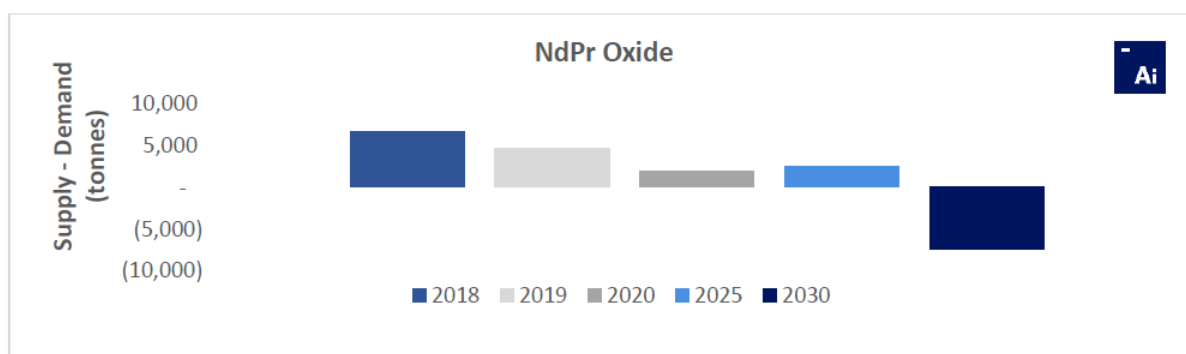
- Efforts engaged by many companies to eliminate REE in general and neodymium in particular from their supply chain following the Chinese export restriction era. It included avoiding REE permanent magnets technologies where possible, and proved successful in some specific functions, notably in the automotive, aerospace, and renewable energies sectors. However, REE performances remain superior in many applications and are likely to be used if prices and availability are favourable;
- The present context of anticipated growth for green energy and green transportation initiatives. These sectors, as well as increasing demand for air conditioning by Indian and other South-East Asian customers remain potential important markets for REE-based permanent magnets (Rare Earth Investment News, 2016; Powder Metallurgy review, 2016)

From 2018 through 2030, Adamas Intelligence (2019) forecasts that global annual production of neodymium oxide and praseodymium oxide (or oxide equivalents) will increase at a slower rate than global demand, resulting in the draw-down of producer inventories and, ultimately, shortages of these materials if supply is not increased beyond what is currently anticipated.



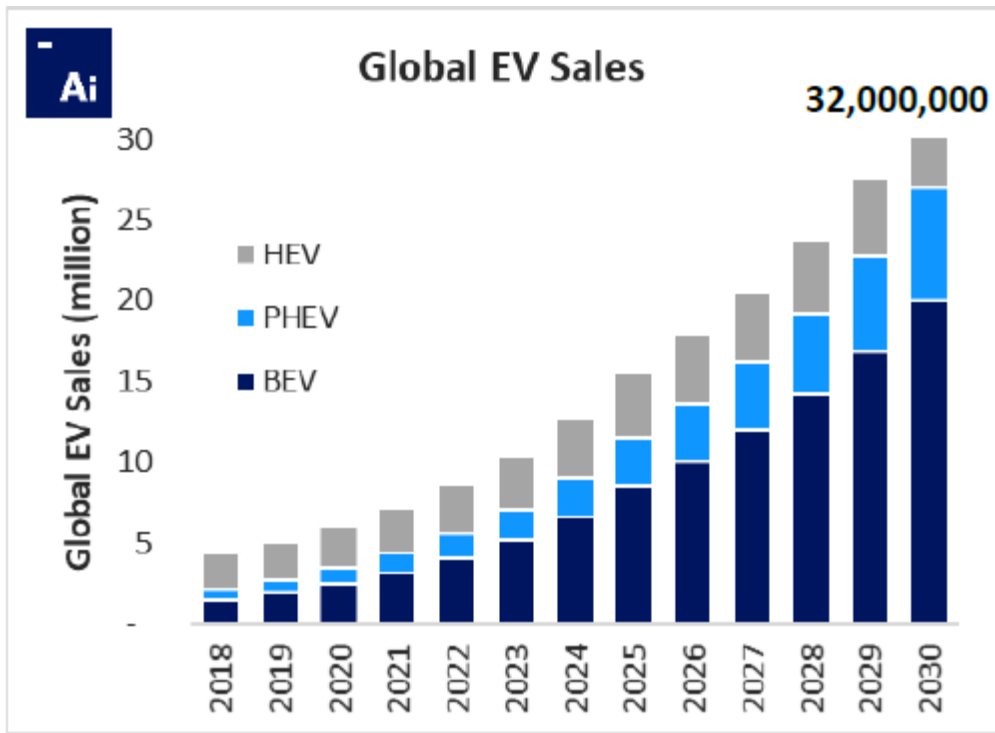
**Figure 350: Global annual demand of neodymium oxide to exceed global annual production in 2030 (Adamas Intelligence, 2019b)**

Even with substantial production increases in China in the years ahead, and the development of 40,000 tonnes-per-annum of new rare earth oxide production capacity outside China, Adamas Intelligence forecasts that global annual demand for neodymium oxide and praseodymium oxide (combined) will exceed global annual production by upwards of 7,500 tonnes in 2030 – equal to the amount of material needed for production of approximately 6.7 million EV traction motors. While Roskill (2019) forecasts the supply-demand balance of neodymium within 1,500 tonnes of supply-demand equilibrium by 2029.



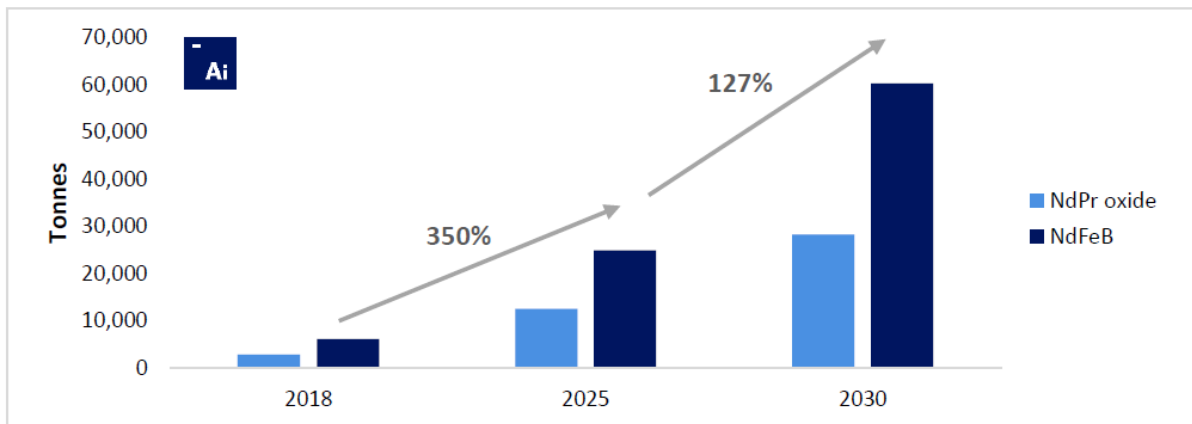
**Figure 351: Global annual demand of neodymium-praseodymium oxide to exceed global annual production by 7,500 tonnes in 2030 (Adamas Intelligence, 2019)**

Adamas Intelligence (2019) forecasts that around 80% of EVs produced in the future will opt to use permanent magnet synchronous motors (PMSM), and with an average peak motor power of 131 kW by 2025 and 152 kW by 2030, will create demand for approximately 25,000 tonnes of NdFeB annually by 2025 and 60,000 tonnes by 2030.



**Figure 352: Global EV sales forecasted to reach 32 million per annum by 2030 (hybrid electric vehicles (HEVs), plug-in hybrids (PHEVs), and battery electric vehicles (BEV)) (Adamas Intelligence, 2019)**

Taking into account the yields and losses incurred during metal, alloy and magnet production, we forecast that demand for NdPr oxide for EV traction motors will increase from approximately 3,000 tonnes in 2018 to 13,000 tonnes in 2025 and 28,000 tonnes in 2030 – equal to approximately 20% of total global demand in 2030.



**Figure 353: Changes in total rare earth demand for EV traction motors to increase by 350% between 2018 and 2025 (Adamas Intelligence, 2019)**

Adamas Intelligence estimates that, on average, a PMSM for an EV contains approximately 1.2 kg of NdFeB magnets per 100 kW of peak motor power yielded. During production of this 1.2 kg of NdFeB magnets, Adamas estimates that an additional 0.4 kg of NdFeB alloy is diverted to waste streams during casting, crushing, milling, sintering, cutting, grinding, coating and inspection of the final magnets, and as such, a total of 1.6 kg of NdFeB alloy is consumed per 100 kW of peak motor power.

In 2018, Adamas Intelligence indicates that globally, the sales-weighted-average EV's 93 kW traction motor, almost double what it was in 2011. Looking forward to 2025, Adamas forecasts that as BEV sales growth continues to outpace PHEV and HEV sales growth globally, the sales-weighted-average motor power will increase to 131 kW in 2025, creating demand for 1.0 kilogram of NdPr oxide (and minor Dy/Tb) for every new EV equipped with a PMSM.

**Table 145: Current and future use of in a permanent magnet traction motor (Adamas Intelligence, 2019)**

	Material Intensity (Per 100 kW) *	Avg. EV Motor in 2018 (93 kW)	Avg. EV Motor in 2025 (131 kW)
<b>NdFeB</b>	1.6 kg	1.5 kg	2.0 kg
<b>NdPr metal</b>	0.6 kg	0.5 kg	0.8 kg
<b>NdPr oxide</b>	0.7 kg	0.7 kg	1.0 kg

\* Magnet, metal and oxide mass estimates account for material losses from oxide to metal to alloy to finished NdFeB

### 21.2.2.9 Samarium

The overall demand for samarium is expected to increase by around 10% per year until 2020 (EC, 2014). The future evolution of samarium demand is driven by the anticipated growth of the permanent magnet market.

### 21.2.2.10 Terbium

The demand of terbium is likely to drop in the future because of the reduction of rare earth needs for the lighting industry (this industry is currently representing 68% of terbium applications). This reduction is expected to amount to at least 65% between 2015 and 2030 (Guyonnet et al., 2015). This evolution is due to the changes in the lighting market structure and is driven by two forces:

- The anticipated decrease of the fluorescent lamps market face to the growing new technology LEDs: in the lighting market as a whole, LED lighting penetration is projected to be around 40% in 2016 and over 60% in 2020 (Mc Kinsey, 2012).
- The content of rare earths (including Tb) in LEDs is much lower than in fluorescent lamps (1,000 times lower) (Guyonnet et al., 2015).
- As the lifetime of LED is 40,000-50,000 hours, compared to 10,000-25,000 hours for fluorescent lamps, the decrease in rare earth need for the lighting sector will amplify in the coming years (Guyonnet et al., 2015).

### 21.2.2.11 Yttrium

The demand of yttrium is likely to drop in the future because of the reduction of rare earth needs for the lighting industry (this industry is currently representing 46% of yttrium applications). This reduction is expected to amount to at least 65% between 2015 and 2030 (Guyonnet et al., 2015). This evolution is due to the changes in the lighting market structure and is driven by two forces:

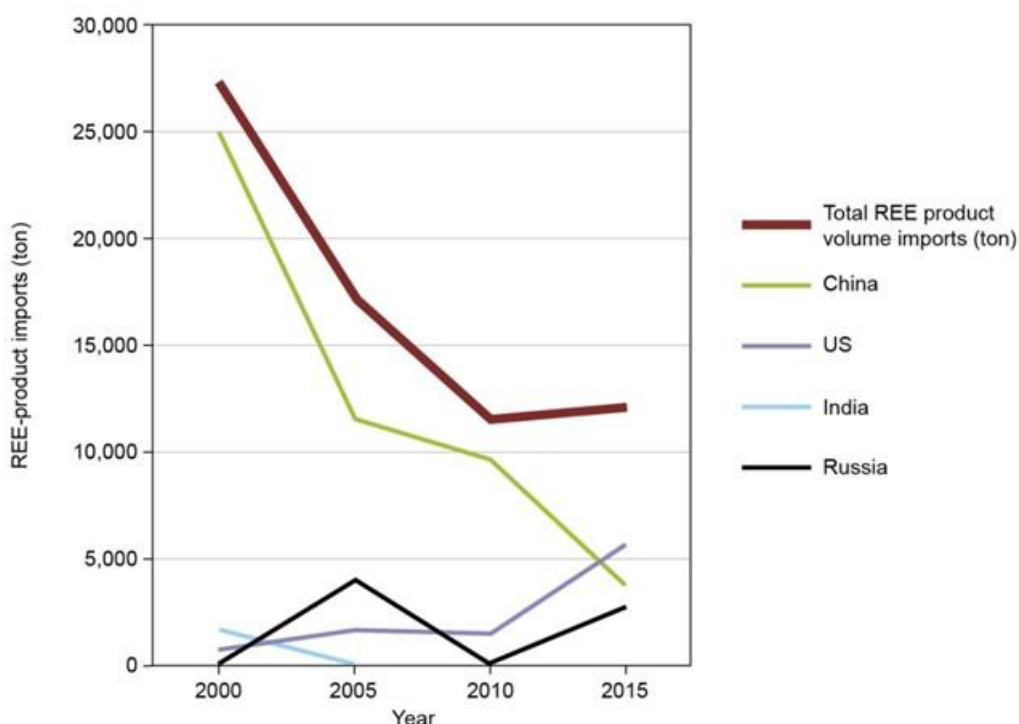
The content of rare earths (including Y) in LEDs is much lower than in fluorescent lamps (1,000 times lower) (Guyonnet et al., 2015).

As the lifetime of LED is 40,000-50,000 hours, compared to 10,000-25,000 hours for fluorescent lamps, the decrease in rare earth need for the lighting sector will amplify in the coming years (Guyonnet et al., 2015).



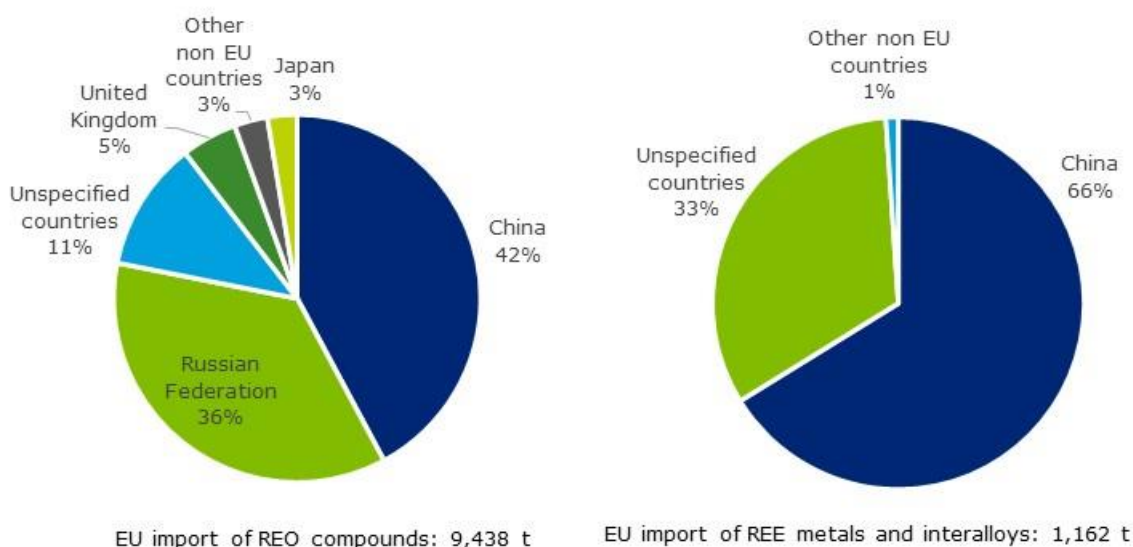
### 21.2.3 EU trade

Import reliance on REOs compounds and REE metals and interalloys is 100%.

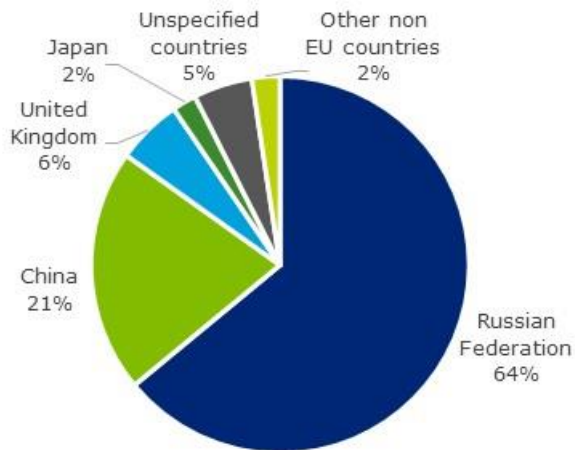


**Figure 354: Total EU-import of REE-metals and -compounds, 2000 – 2015. (MiMa-GEUS with data retrieved from Eurostat, 2016. Note: REE-metal and – alloy imports are summarized from four HS product codes (28053010, 28053090, 28461000 and 28469000) for which data is available for the time period, and by importing country (Machacek and Kalvig (edit) 2017).**

The EU is entirely dependent on imports of REE for its consumption. The average EU imports during the 2016-2018 period were 9,438 tonnes of REE compounds, 1,162 tonnes of REE metals and interalloys, while the EU exports were 5,464 tonnes of REE compounds and 601 tonnes of REE metals and inter-alloys.



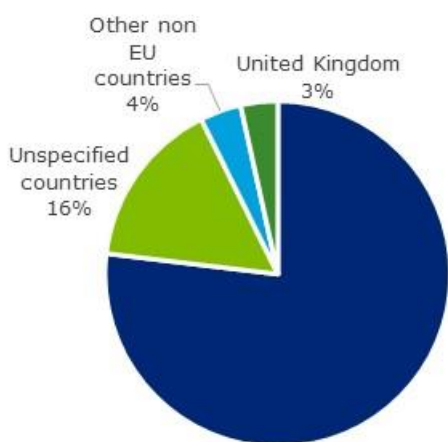
**Figure 355: EU imports of REE compounds (CN8 2846-1000, -9010 and -9020) and REE metals and interalloys (CN8 2805-3010, -3020, -3030) (Eurostat Comext, 2019).**



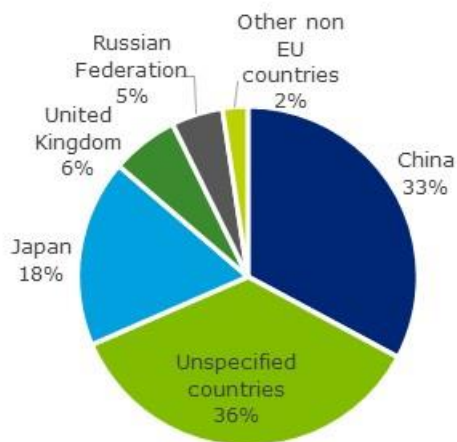
EU imports of Cerium compounds: 5,241 t

**Figure 356: EU imports of cerium (CN 2846 1000), average 2016-2018(Eurostat, 2019).**

According to EUROSTAT data (CN code 2846 9010) (see Figure 357), the main supplier of the EU is China (77%), followed by United Kingdom (3%) for L-REE (excl. Cerium) compounds (La, Nd, Pr, Sm) expressed in oxide content. As for H-REE compounds (Dy, Er, Eu, Gd, Ho, Tm, Lu, Yb) EUROSTAT data (CN code 28469020). The main supplier of the EU is China (33%), followed by Japan (18%).



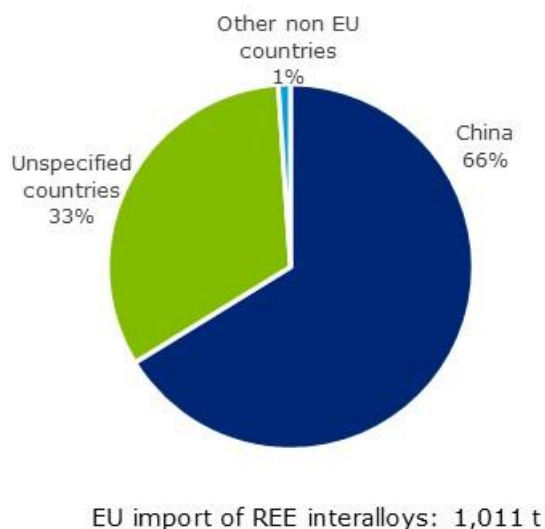
EU imports of LREE compounds: 3,422 t



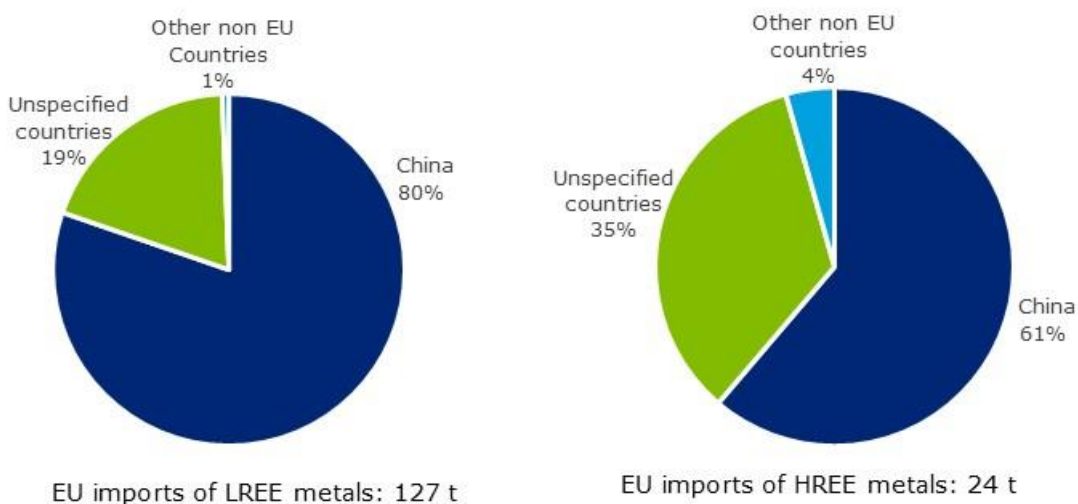
EU imports of HREE compounds: 775 t

**Figure 357: Extra-EU imports of mixed La, Nd, Pr, Sm compounds (LREE except Ce) expressed in oxide content. Extra-EU imports of mixed Dy, Er, Eu, Gd, Ho, Tm, Lu, Yb, Tb and Y compounds (HREE) expressed in oxide content. Average 2016-2018. Data from Eurostat Comext (Eurostat, 2019)**

According to Eurostat Comext, EU imports REE metals and interalloys from China (98-99%). The separation of REE is primarily a technical issue for the global REE-industry, with competency still centred mostly in China.



**Figure 358: Extra-EU imports of intermixtures or interalloys of REE. Average 2016-2018. Data from Eurostat Comext (Eurostat, 2019)**



**Figure 359: Extra-EU imports of LREE (left) and HREE (right) metals. Average 2016-2018. Data from Eurostat Comext (Eurostat, 2019)**

### 21.2.3.1 Trade restrictions

**Table 146: China production and export quota in 2010-2019 in kt (Kingsnorth, 2018)**

year	China production quota	China export quota
2010	89,2	30,3
2011	93,8	30,2

2012	93,8	31
2013	93,8	31
2014	105	30,6
2015	105	-
2016	105	-
2017	105	-
2018	120	-
2019	132	-

Estimated quota for individual REE for the period 2012-2016 are displayed in Table 147. In May 2015, China ended its rare-earth export quotas, removed export tariffs, and began to impose resource taxes on rare earths based on sales value instead of production quantity (Metal Pages, 2015).

Export quotas are provided by OECD (2019) and the relative production of individual REO relative concentration in deposits is used to calculate quota. Imports and quotas are shown in Table 147.

**Table 147: Imports and quotas (Eurostat, 2019; OECD, 2019) <sup>226</sup>**

REE		EU imports <sup>1</sup>	Imports evolution over 2010-14 <sup>1</sup>	Chinese quotas <sup>2</sup>	Additional export tax <sup>3</sup>
		tonnes		tonnes REO/y	
LREE	Ce	5,763	-	13,743	no
	Nd	532	↑	4,892	15%
	La	3,408	↑↑	7,608	15%
	Pr	216	↑	1,454	15%
	Sm	33	↑	671	25%
HREE	Eu	36	↑	113	25%
	Tb	36	↑	55	25%
	Gd	18	↑	429	25%
	Er	13	↑	130	25%
	Dy	18	↑	273	25%
	Y	778	↑	1,454	25%
	Ho, Tm, Lu, Yb	13	-	177	15%

Legend: ↑↑ increased steadily  
 ↑ slight increase

### 21.2.3.2 Relevant trade codes

From 2016 on the Eurostat (2019) product codes provide more detail on the individual REE imported (see Table 148 **Error! Reference source not found.**). Therefore, the results are shown by averaging data from 2016 to 2018. Cerium, LREE (excluding Ce) and HREE have specific code in Eurostat Comext database, split in rare earth metals and compounds. The use of term "compound" opens for various interpretations, such as to whether it refers to different types of compounds (metals, alloys, oxides, salts), and thus, REE that encompasses all types of compounds, or whether it refers to rare earth metals, as metals of individual elements in form of alloys.

At the extraction stage, REE are assessed as mixes of REO or low purity single REE ores and concentrates (this roughly corresponds to mining + first stages of processing / separation). CN8 codes used for this stage are: 28461000 "Cerium compounds", 28469010 "Compounds of lanthanum, praseodymium, neodymium or samarium, inorganic or organic" and 28469020 "Compounds of europium, gadolinium, terbium, dysprosium, holmium, erbium, thulium, ytterbium, lutetium or yttrium, inorganic or organic". Eurostat data have been reported as REO content by using the conversion factors (see Table 182 **Error! Reference source not found.**).

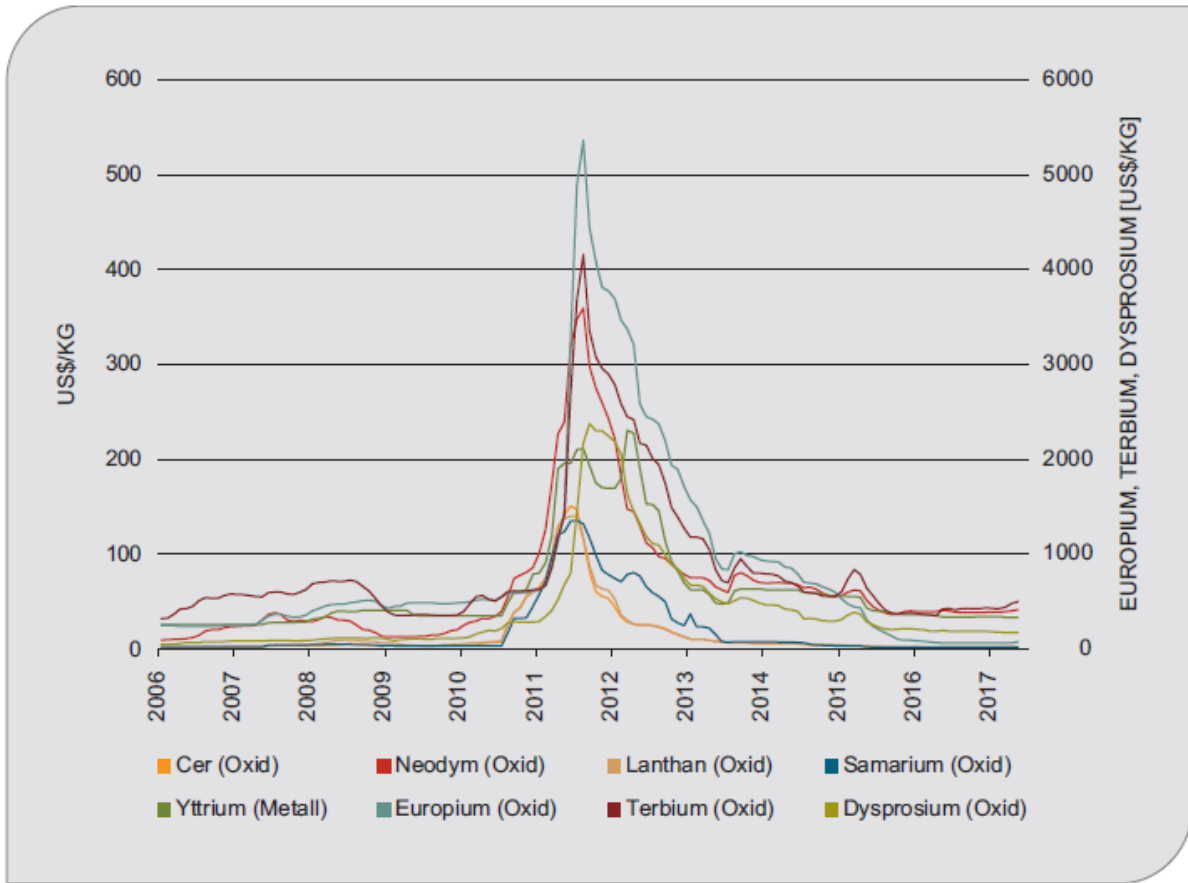
At the processing stage, high purity single REE (this correspond to advanced separation / refining) are assessed. The trade codes used for EU trade are CN8: 28053010 "Intermixtures or interalloys of rare-earth metals, scandium and yttrium", 28053020 "Cerium, lanthanum, praseodymium, neodymium and samarium, of a purity by weight of  $\geq 95\%$  (excl. intermixtures and interalloys)", 28053030 "Europium, gadolinium, terbium, dysprosium, holmium, erbium, thulium, ytterbium, lutetium and yttrium, of a purity by weight of  $\geq 95\%$  (excl. intermixtures and interalloys)". Eurostat reports some trade data under the label "Countries and territories not specified for commercial or military reasons in the framework of trade with third countries". For the purpose of the assessment and to calculate the supply risk, this share of import has been combined with China, because of its leading position within the REE market. However, charts in this factsheet report the shares of this trade flow as "Unspecified countries".

**Table 148: List of CN codes on REE available on Comext Eurostat (2019)**

<b>CN codes</b>	<b>Label</b>
28053010	Intermixtures or interalloys of rare-earth metals, scandium and yttrium
28053020	Cerium, lanthanum, praseodymium, neodymium and samarium, of a purity by weight of $\geq 95\%$ (excl. intermixtures and interalloys)
28053030	Europium, gadolinium, terbium, dysprosium, holmium, erbium, thulium, ytterbium, lutetium and yttrium, of a purity by weight of $\geq 95\%$ (excl. intermixtures and interalloys)
28053080	Rare-earth metals, scandium and yttrium, of a purity by weight of $< 95\%$ (excl. intermixtures and interalloys)
28053090	Rare-earth metals, scandium and yttrium (excl. intermixtures or interalloys)
28461000	Cerium compounds
28469000	Compounds, inorganic or organic, of rare-earth metals, of yttrium or of scandium or of mixtures of these metals (excl. cerium)
28469010	Compounds of lanthanum, praseodymium, neodymium or samarium, inorganic or organic
28469020	Compounds of europium, gadolinium, terbium, dysprosium, holmium, erbium, thulium, ytterbium, lutetium or yttrium, inorganic or organic
28469090	Compounds of mixtures of rare-earth metals, yttrium and scandium, inorganic or organic

## **21.2.4 Prices and price volatility**

Prices of REE experienced great variations in the last decade, as shown in Figure 360. In 2010-2011 a 12-fold increase was observed, mainly triggered by a strong reduction of Chinese export quotas and geopolitical tension in a period of high demand for permanent magnets, driven by the expected growth of the renewable energy and electric vehicles markets. From early 2012, prices were already down by half and went down almost continuously until 2019, showing short-term volatility.



**Figure 360: Rare-earths oxide prices 2006-2017. 99% FOB China USD/kg. (Asian Metal from DERA, 2018)**

**Table 149: Significant historical events that have affected rare earth prices (Roskill, 2019)**

1983	NdFeB magnet introduced
1985	Environmental regulations limit lead in gasoline
Late 1980s	China develops its ion adsorption ore deposits
1993	Regulations mandating the use of auto catalysts
1994	Rhodia switches to Chinese feedstock
1994	Chinese producers form a cartel to stop price cutting
1997-99	Asian economic crisis; Chinese cartel collapses
2000	Shortage in supply of Chinese rare earth ores, number of Chinese producers falls to less than 80
2000	Rapid increase in demand by telecommunications and computing industries; prices rise and large number of Chinese producers recommence operations to meet the demands of a rapidly expanding domestic electronics industry
2001-02	Collapse in demand by telecommunications and computing industries; prices fall by 40%
2003	Chinese government attempts to force an industry restructure into two major groups; one centred in Baotou and the other in Southern China, which was unsuccessful. In an effort to stabilise and strengthen prices China announced that it would be introducing rare earth export quotas in 2004.

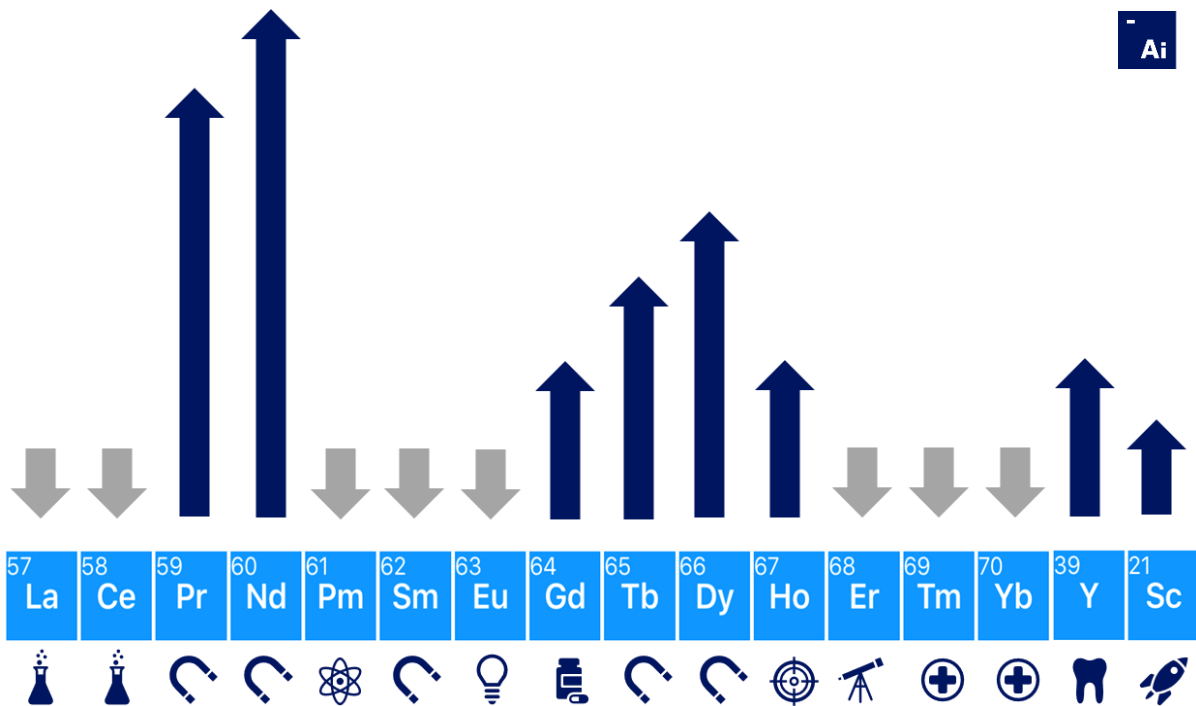
2004	Start of present recovery of rare earth prices due to steady increase in demand. Chinese exports of low value concentrates banned and the VAT rebate eliminated.
2005	Neodymium demand matches supply; leading to a run-down in stocks.
2006	China places quotas on rare earth mineral production and reduces rare earth export quotas. China implements 10% tax on rare earth exports (initially just oxides). In addition, the distribution of mining licences, production quotas and export quotas are used as a means of consolidating the rare earths industry, to enable more government control, resulting in fewer recipients of licences and quotas. The major beneficiaries of this policy have been the major state-owned enterprises such as Baotou Rare Earth and China Minmetals.
2007	Chinese export taxes were increased to 15% or 25%
2008-09	Global economic downturn from the second half of 2008 leads to lower demand for rare earths from North America and Europe and slower growth in China
2010	Chinese rare earth export quota reduced by 40% to encourage downstream production and secure reserves of raw material. Continued limitation on Chinese exports leads to a shortage and sharp increases in the fob price of traditionally low-value rare earths such as lanthanum and cerium, as exporters chose to use their quota for higher value products.
2011	Distorting effect of export quotas on export prices continues. Chinese taxes kept at 15-25% on rare earth metals and oxides in early 2011 but extended to include some alloys. Total export quota remained flat, but inclusion of quota for ferrous alloys (containing >10% rare earths by weight) effectively resulted in a decline in the quota for oxides and metals. From April/May 2011, speculative buying within China boosted prices still further. Sharp fall in purchases from the ROW forced prices downward from August. In November, a resources tax of RMB60/t for LREEs and RMB30/t for HREEs was imposed on rare earth mining companies in China
2012	Destocking following the large inventory build in 2010-11 which followed the Chinese export quota reduction. Thrifing in some application
2013	Continued thrifing in certain applications. Technological innovation in lighting as LEDs began to replace CFLs and led to lower demand and prices for phosphor rare earths
2014	Attempts to drive prices up by stockpiling failed Global oil price fell from U\$100/bbl in mid-2014 to less than US\$60/bbl by the start of 2015, resulting in lower demand for La and Ce in FCC catalysts
2015	Chinese export taxes removed from 2 May 2015 following WTO ruling China's economy grew at a slowing rate - GDP grew by 8.3% and consumer prices by 1.4% in 2015 Chinese output of crude steel declined for the first time that year EV and wind turbine production ramped up worldwide. New incentives resulted in strong growth of EVs in China
2016	Strengthening magnet demand driving global prices for permanent magnet materials, mainly Nd/Pr Withdrawal and reintroduction of Chinese EV incentives because of widespread corruption - EV demand lower than expected this year

	The Chinese economy continued to slow - China's GDP increased by 8% in 2016. Consumer prices, however, strengthened, growing at 1.8%py in 2016.
2017	Price rise as bottomed out and neodymium market tightens In China as producers refused to accept low prices any longer Plant closures following environmental regulation caused some tightness of supply Traders holding stocks on speculation of further price rises; stocks began to be released in the second half of the year Further strengthening of magnet demand from the growing Chinese EV market – pressure building on Nd/Pr supply
2018	USA-China trade war and tariff lists add uncertainty to Chinese dominant commodities
2019	President Xi Jinping visits JL Mag and RE processing facilities in China Chinese officials threaten 'cut-off' of REE exports to USA

#### **21.2.4.1 Prices forecasts**

Adamas Intelligence (2019b) forecasts that prices of high-demand elements, like neodymium, praseodymium, dysprosium and terbium will rise to pay for losses that producers are incurring by necessarily over-producing cerium, lanthanum, and other unsaleable, surplus rare earths; unless new end-uses and applications are developed for them in the near-term. The industries that will feel these price increases the most in the coming decade are those reliant on use of high-strength rare earth permanent magnets, such as the automotive industry, the wind power sector, the consumer electronics industry, the defence industry, and many others.





**Figure 361: Prices of some rare earths are expected rise to compensate for losses incurred on other surplus rare earths (Adamas Intelligence, 2019b).**

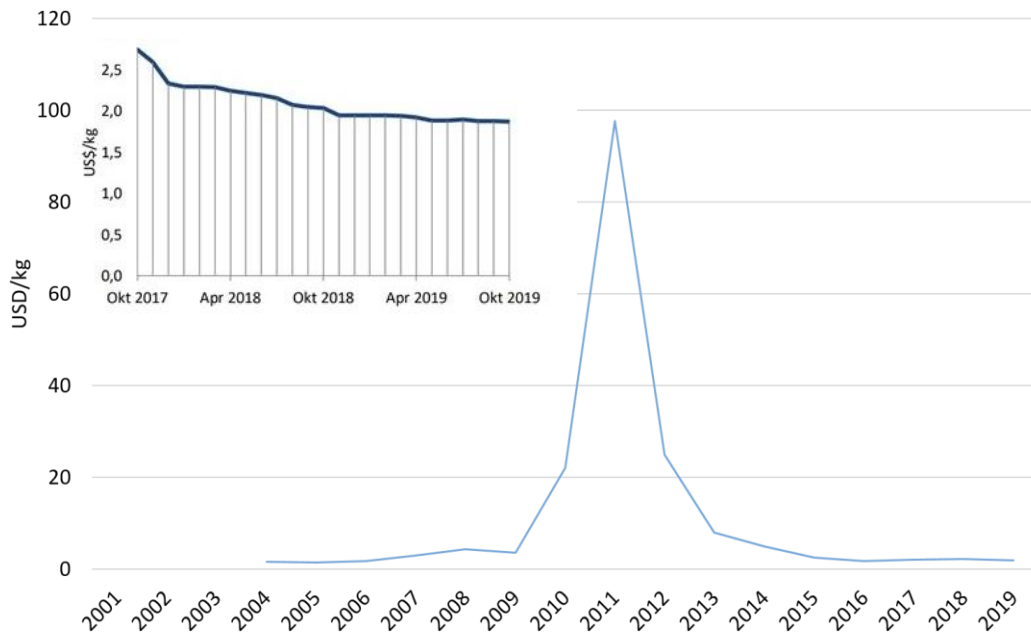
#### 21.2.4.2 Cerium prices

Prices of cerium metal and oxide experienced great variations from 2010 to 2014. After a sharp increase from 2010 to 2011, from USD 3 per kg in 2002-2003 to an all-time high of USD 170 per kg in July 2011, prices of Ce metal went down to reach a relatively stable value of around USD 6 per kg in 2015 and 2016 (DERA, 2019). The skyrocketing of prices in 2010 – 2011 was triggered by the strong reduction of Chinese quotas.

High prices in 2011 reinforced the role of China as the worldwide larger producer of Ce polishing powders, also considering its dominance in manufacturing of glass products and electrical components. Research activities are being carried out in China to improve the quality of polishing powders based on CeO<sub>2</sub>, in particular by applying the CMP (i.e. Chemical Mechanical Planarisation) method to obtain higher grades powders for the polishing of electronic components (Roskill, 2016).

The price spike in 2011 boosted the industrial research both for improved technical solutions enabling the reduction of Ce use, as well as for alternative materials such as zirconia (especially for lower quality products). However, as price decreased again, these efforts to find substitutes were put on hold and the traditional use of CeO<sub>2</sub> were maintained.

According to Roskill (2019), nominal prices for cerium are forecast to remain mostly flat over the forecast period to 2028, remaining below US\$2/kg. Relatively low prices will be ensured by continued oversupply as the drive to produce larger quantities of magnet materials will also result in large quantities of cerium production, effectively as waste.

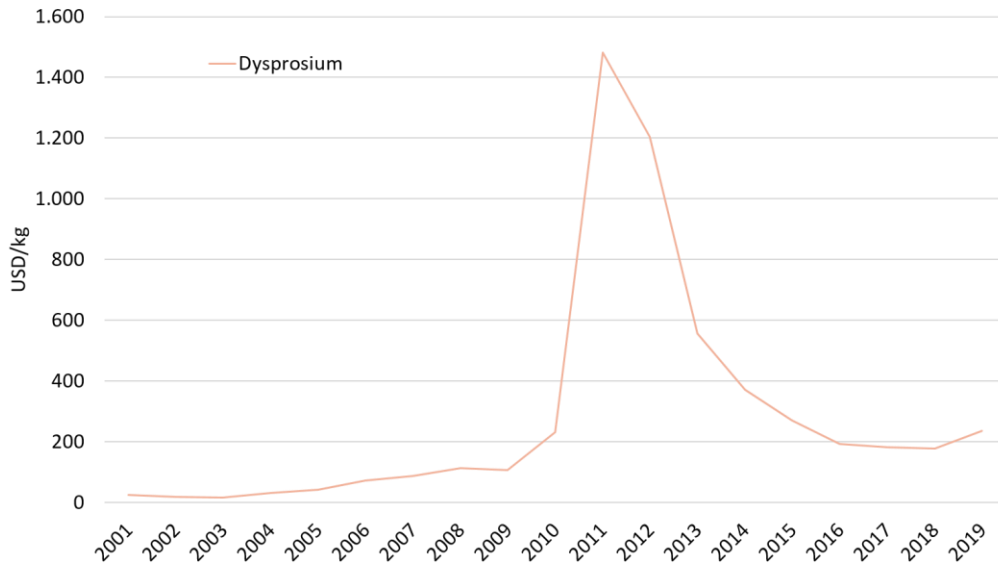


**Figure 362: Annual average prices of 99% cerium oxide in USD/kg from 2004 to 2019 (FOB China, DERA 2019)**

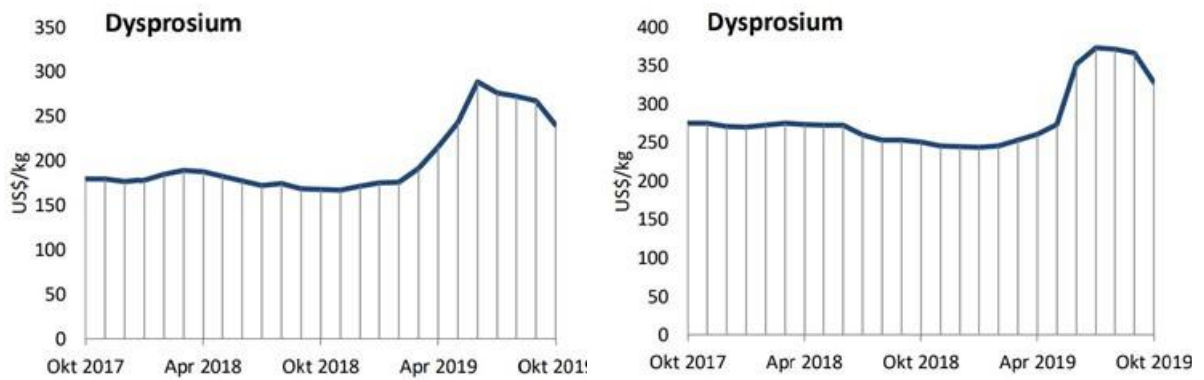
#### 21.2.4.3 Dysprosium prices

Prices of dysprosium metal and oxide experienced great variations from 2010 to 2016. Dy oxide prices (99% FOB China) went from USD 30 per kg in 2002-2003 to an all-time high of USD 3,400 per kg in July 2011. Since then, they have continuously decreased to around USD 600 per kg in 2014, to USD 320 per kg in 2015, USD , and USD 190 per kg in 2017, and increased to USD 310 per kg in 2019 (DERA, 2019).

According to Roskill (2019), dysprosium prices are forecast to continue their decline in 2020, after being inflated for much of 2019. The supply of dysprosium should tighten following growing demand for NdFeB magnets from EVs and move into deficit by 2023. As supply of HREEs is more restricted compared to neodymium and other LREEs, the price is likely to see more volatility. Much like neodymium, dysprosium is forecast to see a widening supply gap from the end of the 2020s, which will require additional supply to maintain balance and price stability.

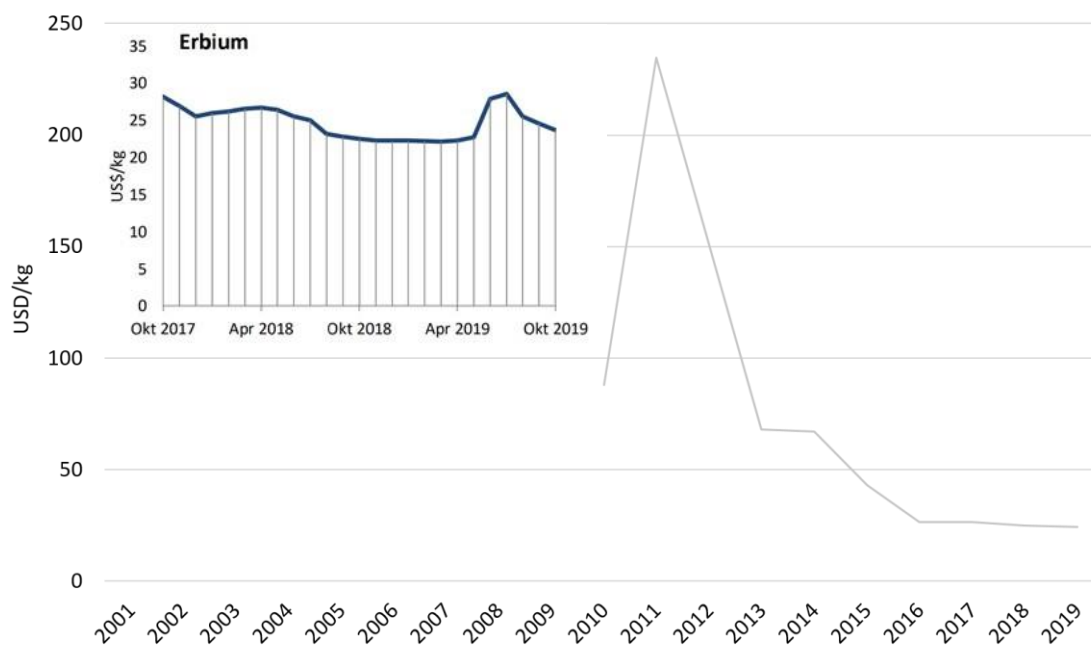


**Figure 363: Annual average prices of 99% dysprosium oxide in USD/kg from 2001 to 2019 (FOB China, DERA 2019)**



**Figure 364: Prices of 99% dysprosium oxide (left) and dysprosium metal (right) price in USD/kg from 2017 to 2019 (FOB China, DERA 2019)**

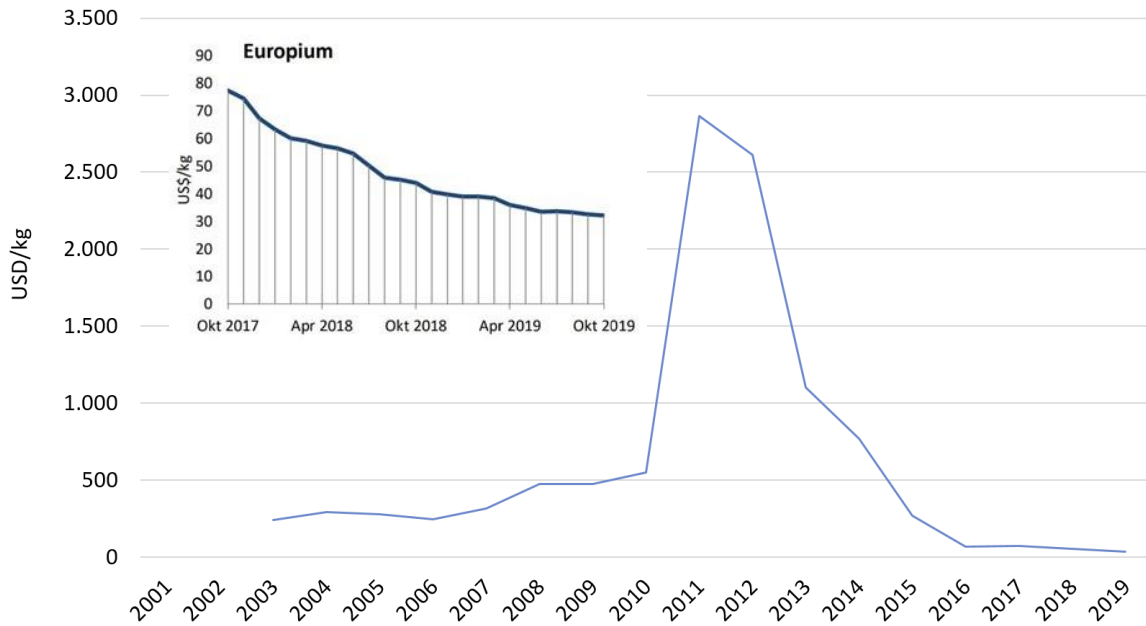
#### 21.2.4.4 Erbium prices



**Figure 365: Annual average prices of 99% erbium oxide in USD/kg from 2010 to 2019 (FOB China, DERA 2019)**

#### 21.2.4.5 Europium prices

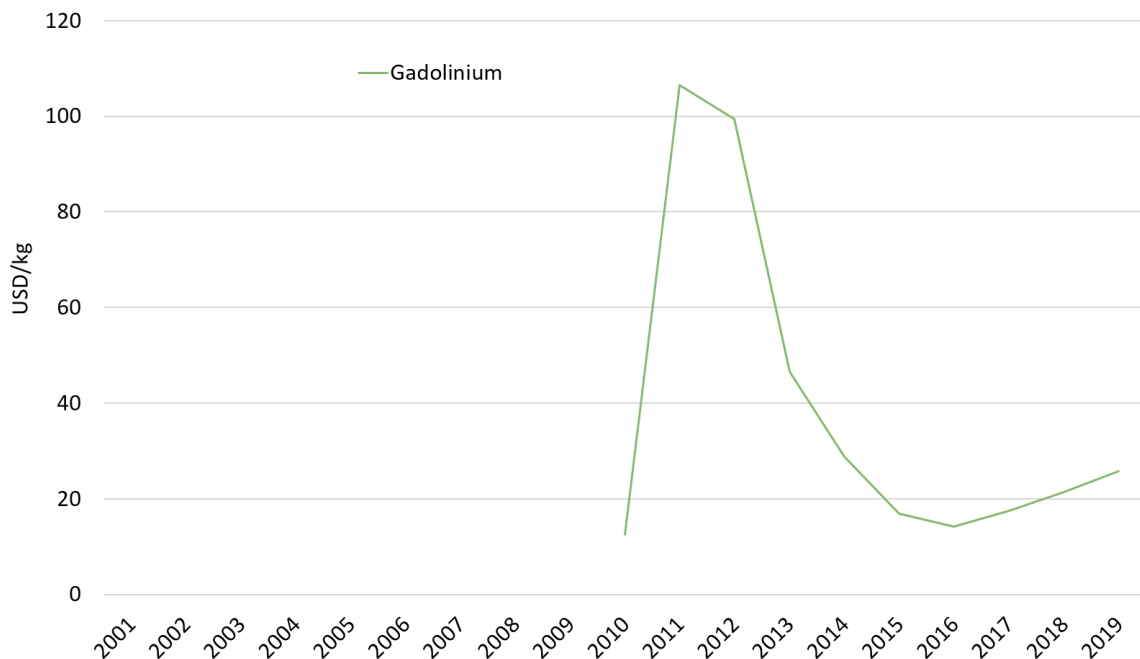
Prices of europium metal and oxide experienced great variations from 2010 to 2016. Eu oxide prices (99% FOB China) went from USD 785 per kg in 2002-2003 to an all-time high of USD 6,800 per kg in July 2011 (one of the highest growth ever for metal prices). Since then, they have continuously decreased, to USD 445 per kg in 2015, USD 70 per kg in 2017 and USD 35 per kg in 2019 (DERA 2019). Despite europium was for more than 15 years the most expensive of all the REE, its uses and value have decreased and terbium took the lead in 2014-2015.



**Figure 366: Annual average prices of 99% europium oxide in USD/kg from 2003 to 2019 (FOB China, DERA 2019)**

#### 21.2.4.6 Gadolinium prices

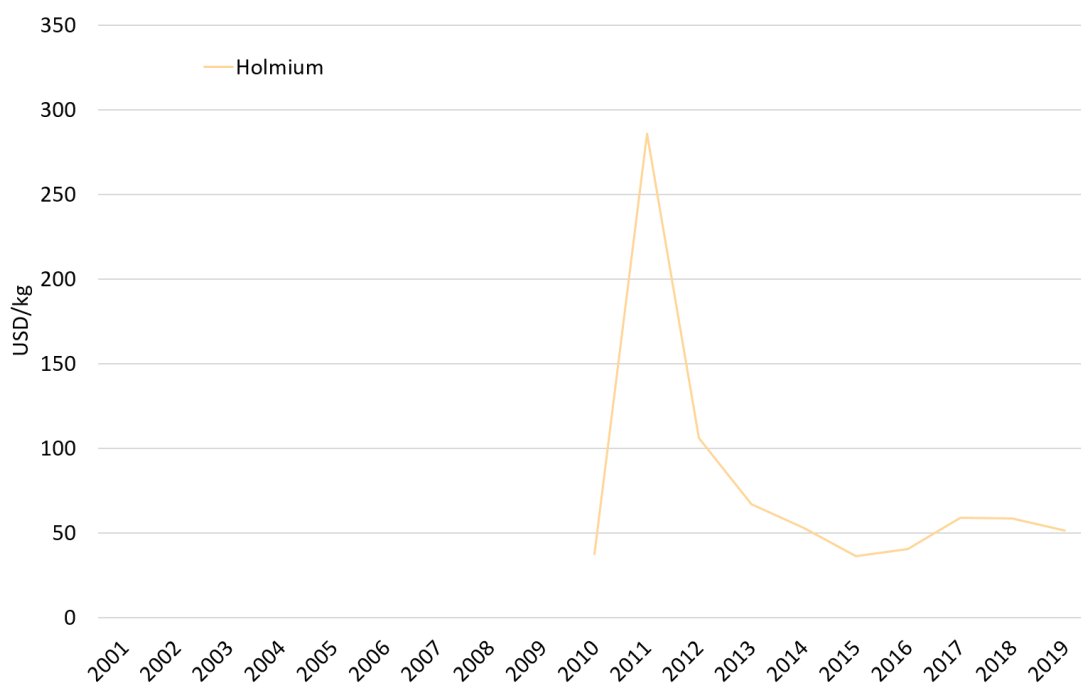
Prices of gadolinium metal and oxide experienced great variations from 2010 to 2014. After a sharp increase from 2010 to 2011, from USD 30 per kg in 2008 to an all-time high of USD 226 per kg in July 2011, prices of Tb metal went down to reach a relatively stable value of around USD 61 per kg in 2015 (BRGM, 2015).



**Figure 367: Annual average prices of 99% gadolinium oxide in USD/kg from 2010 to 2019 (FOB China, DERA 2019)**

### 21.2.4.7 Holmium, Lutetium, Ytterbium, Thulium prices

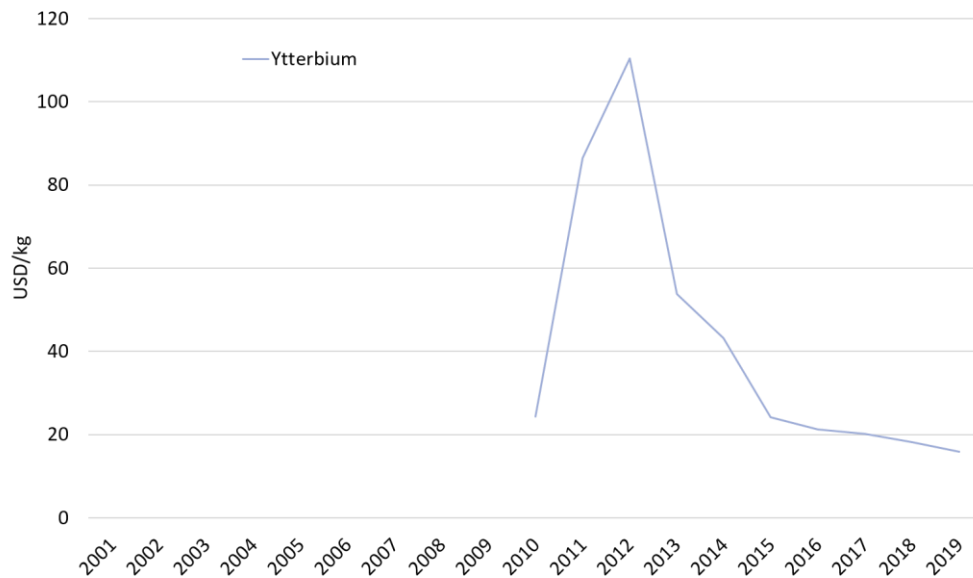
No data for thulium prices is available.



**Figure 368: Annual average prices of 99% holmium oxide in USD/kg from 2010 to 2019 (FOB China, DERA 2019)**



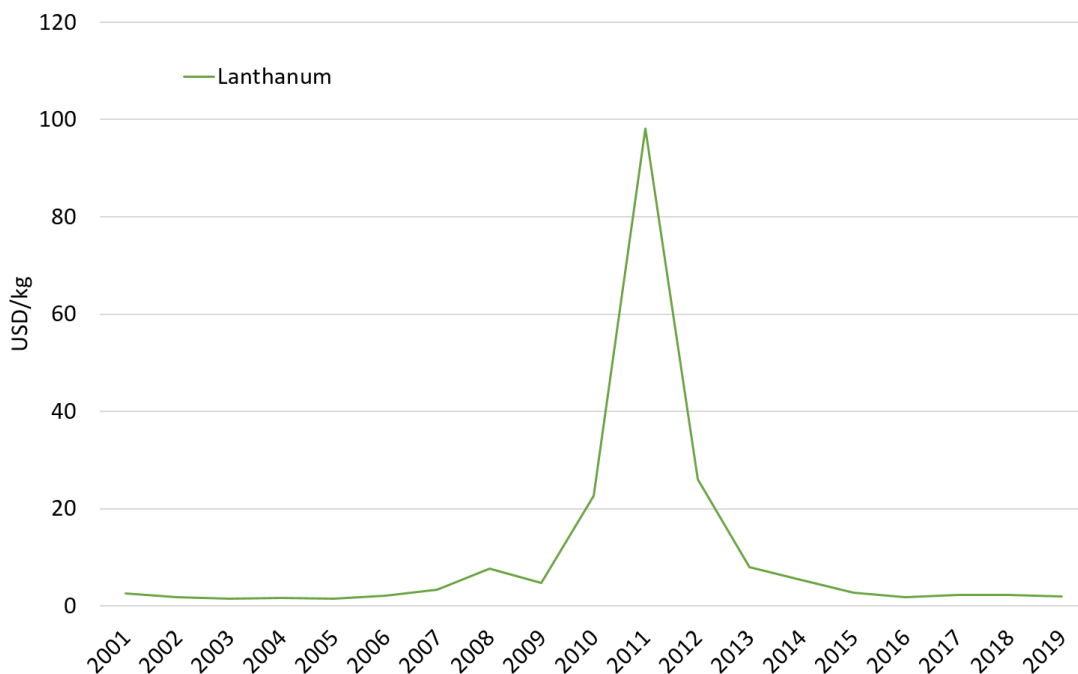
**Figure 369: Annual average prices of 99% lutetium oxide in USD/kg from 2010 to 2019 (FOB China, DERA 2019)**



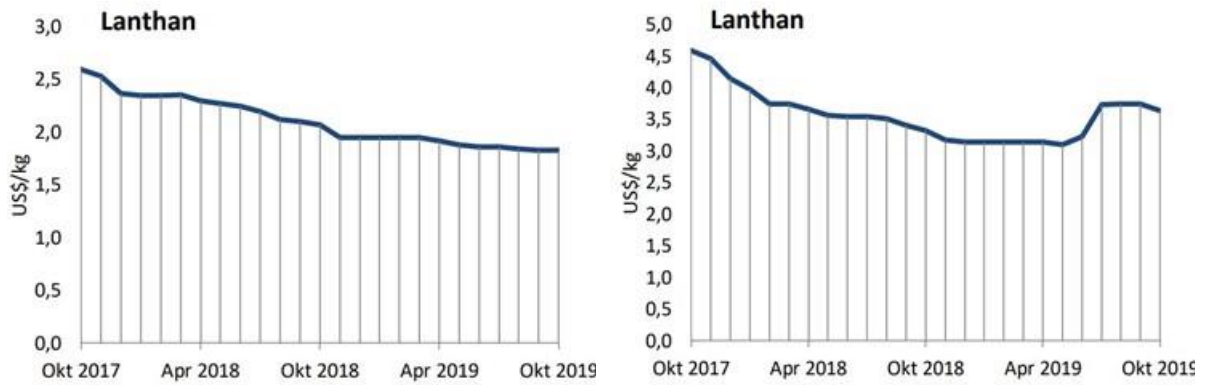
**Figure 370: Annual average prices of 99% gadolinium oxide in USD/kg from 2010 to 2019 (FOB China, DERA 2019)**

#### 21.2.4.8 Lanthanum prices

Prices of lanthanum metal and oxide experienced great variations from 2010 to 2014. After a sharp increase from 2010 to 2011, from USD 3 per kg in 2002-2003 to an all-time high of USD 166 per kg in July 2011, prices of La metal went down to reach a value of around USD 6 per kg in 2015 (BRGM, 2015) and USD 4 per kg in 2019 (DERA 2019).



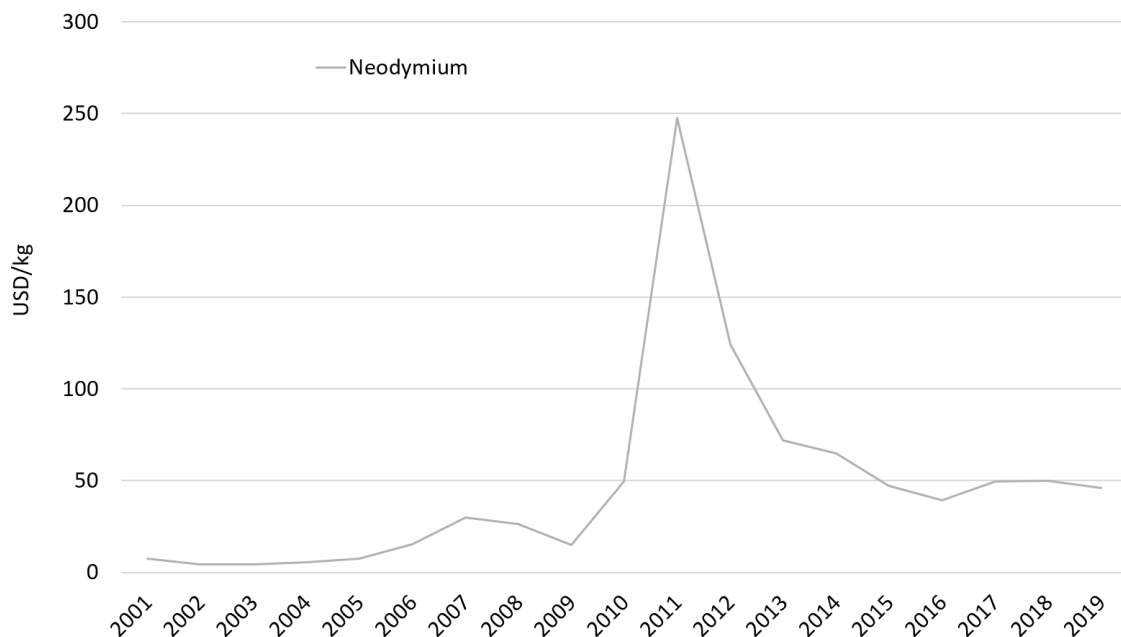
**Figure 371: Annual average prices of 99% lanthanum oxide in USD/kg from 2001 to 2019 (FOB China, DERA 2019)**



**Figure 372: Prices of 99% lanthanum oxide (left) and 99.999% lanthanum oxide (right) in USD/kg (FOB China, DERA 2019)**

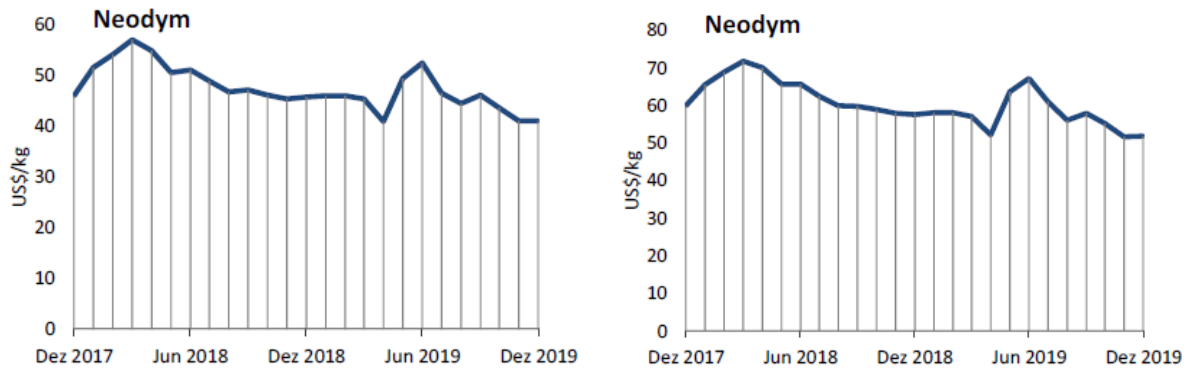
#### 21.2.4.9 Neodymium prices

Prices of neodymium metal and oxide experienced great variations from 2010 to 2014. After a sharp increase from 2010 to 2011, from USD 7 per kg in 2002-2003 to an all-time high of USD 467 per kg in July 2011, prices of Nd metal went down to reach a relatively stable value of around USD 60 per kg in 2015-2019 (DERA, 2019).



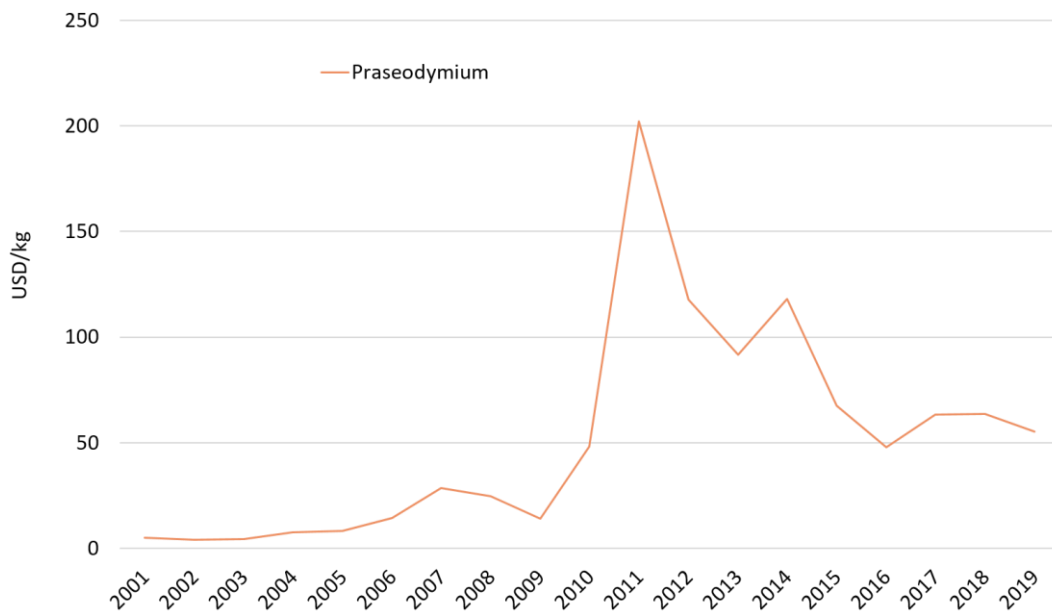
**Figure 373: Annual average prices of 99% neodymium oxide in USD/kg from 2001 to 2019 (FOB China, DERA 2019)**



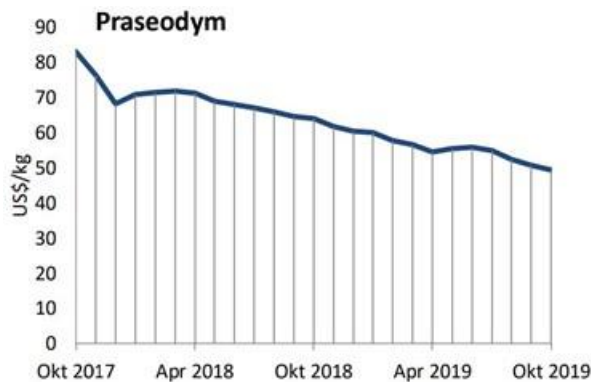


**Figure 374: Prices of 99% neodymium oxide (left) and neodymium metal (right) price in USD/kg (FOB China, DERA 2019)**

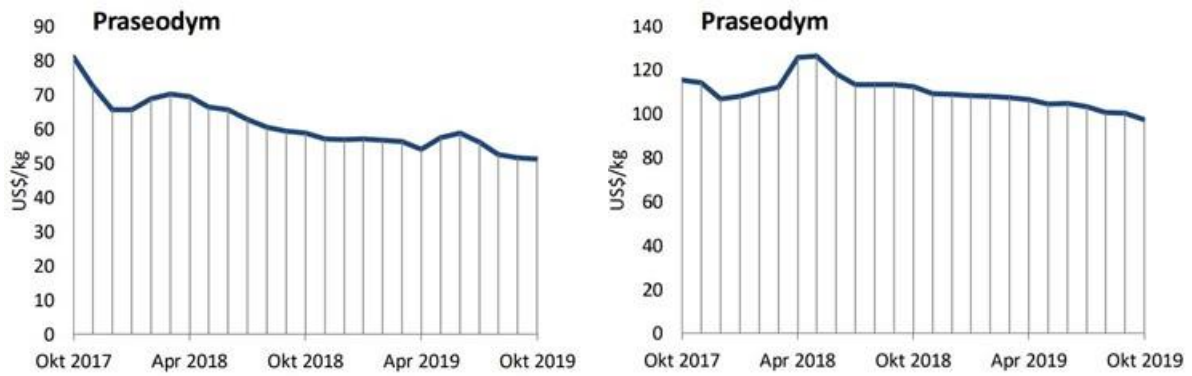
#### 21.2.4.10 Praseodymium prices



**Figure 375: Annual average prices of 99% praseodymium oxide in USD/kg from 2001 to 2019 (FOB China, DERA 2019)**



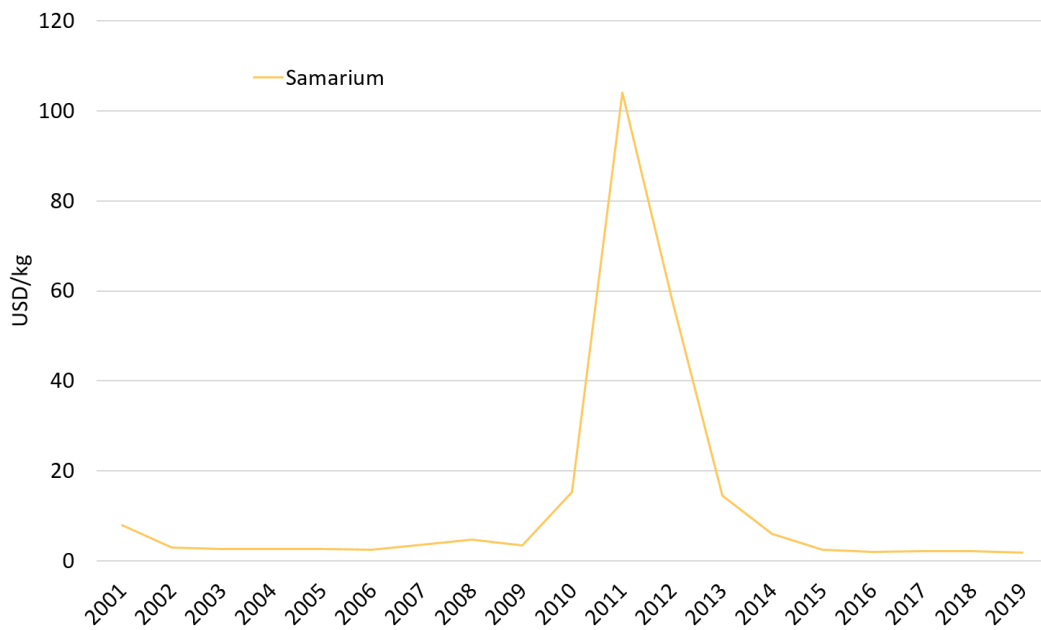
**Figure 376: Pr oxide price; 99% Europe. DERA 2019 China USD/kg**



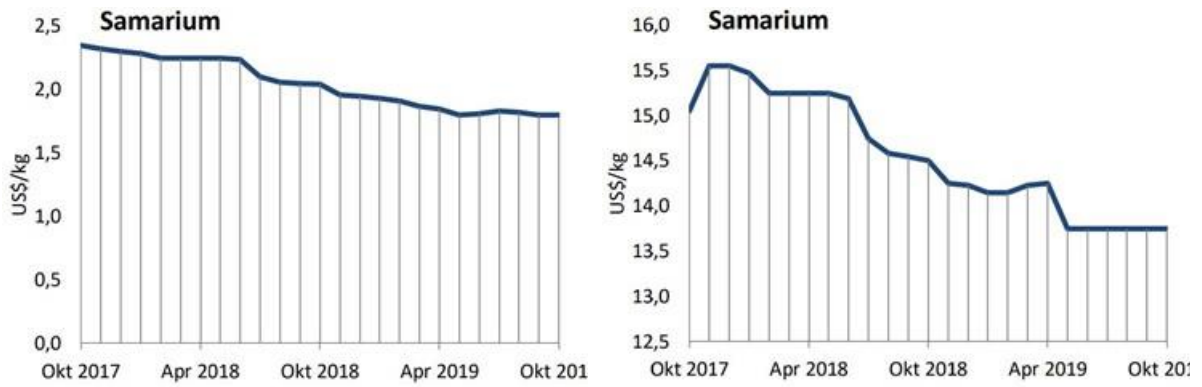
**Figure 377: Pr oxide 99% (left) and Pr metal (right) price. Data from DERA 2019 99% FOB China USD/kg**

#### 21.2.4.11 Samarium prices

Prices of samarium metal and oxide experienced great variations from 2010 to 2014. After a sharp increase from 2010 to 2011, from USD 13 per kg in 2002-2003 to an all-time high of USD 190 per kg in July 2011, prices of Sm metal went down to reach a relatively stable value of around USD per kg in 2019 (DERA 2019).



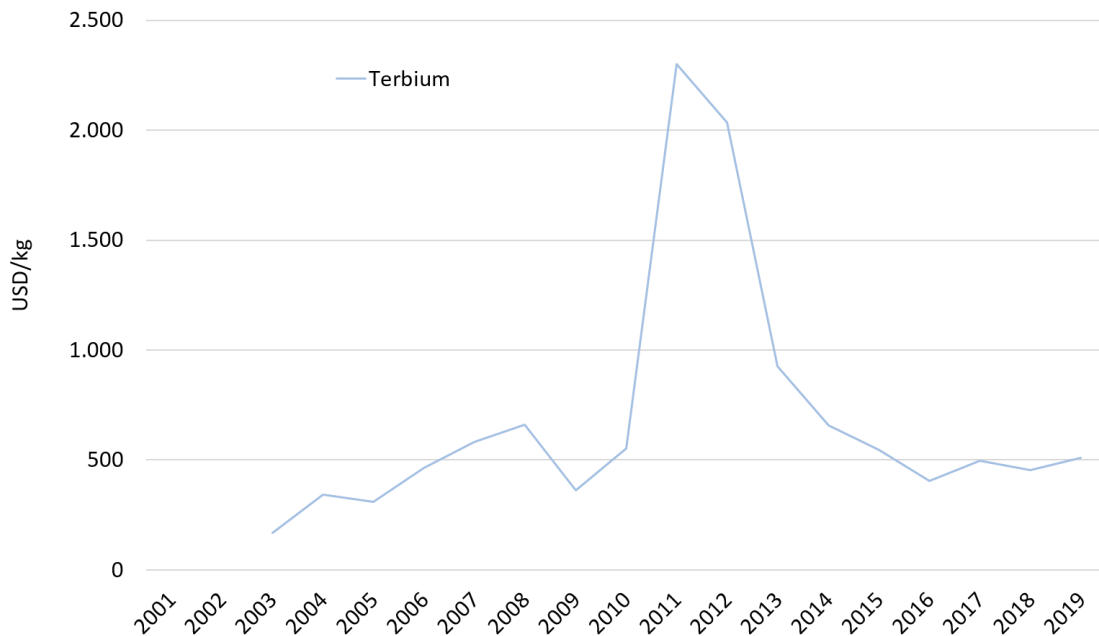
**Figure 378: Annual average prices of 99% samarium oxide in USD/kg from 2001 to 2019 (FOB China, DERA 2019)**



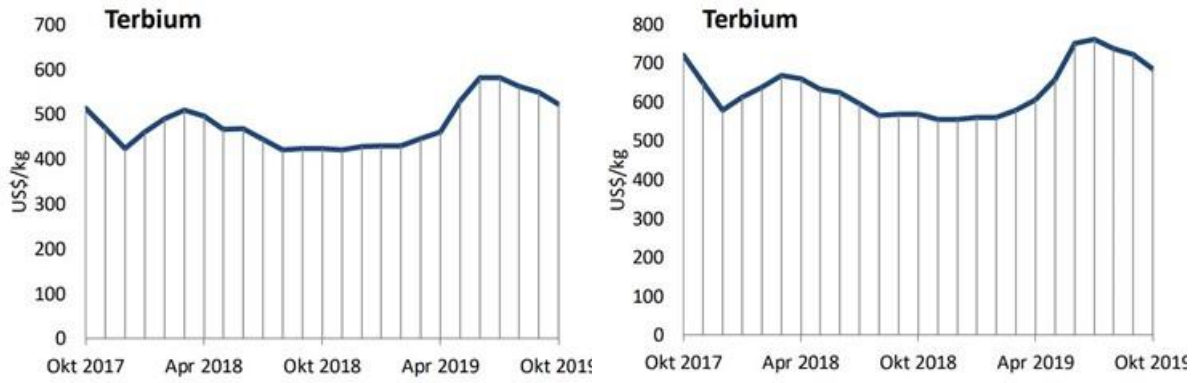
**Figure 379: Sm oxide 99% (left) and Sm metal (right) price. Data from DERA 2019 99% FOB China USD/kg**

#### 21.2.4.12 Terbium prices

Prices of terbium metal and oxide experienced great variations from 2010 to 2014. After a sharp increase from 2010 to 2011, from USD 200 per kg in 2002-2003 to an all-time high of USD 5,100 per kg in July 2011, prices of Tb metal went down to USD 700 per kg in 2015-2019 (DERA, 2019).



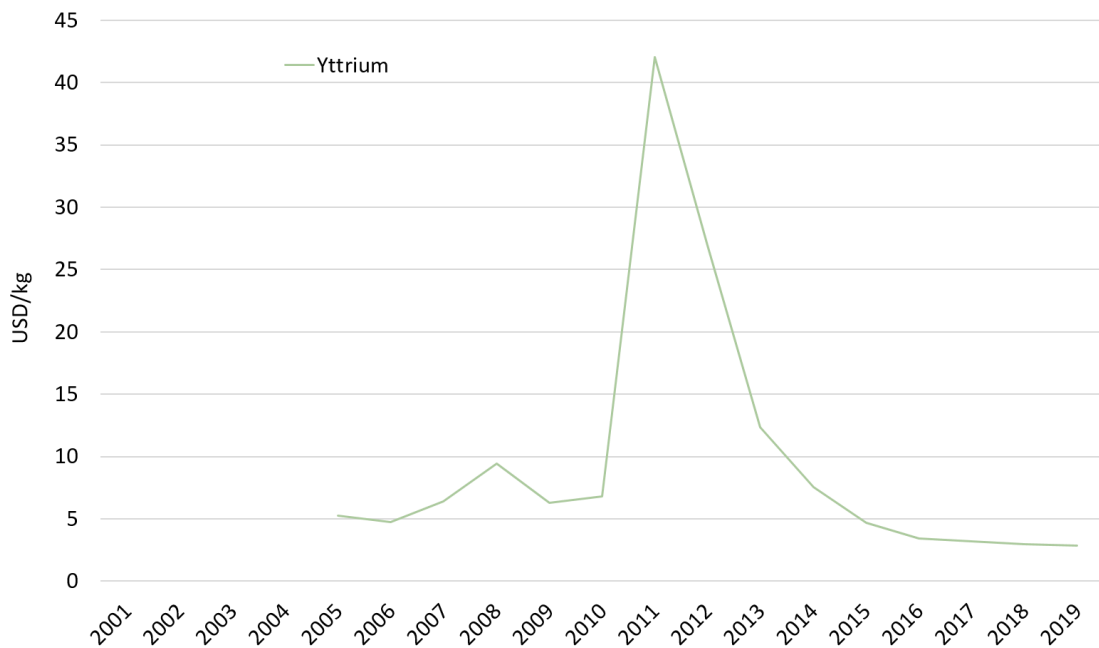
**Figure 380: Annual average prices of 99% terbium oxide in USD/kg from 2003 to 2019 (FOB China, DERA 2019)**



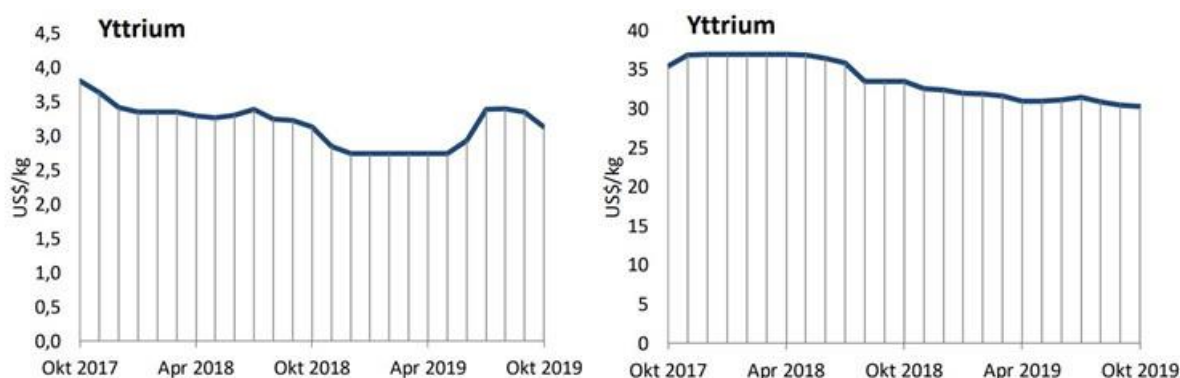
**Figure 381: Terbium oxide 99% (left) and metal (right) price. Data from DERA 2019 99% FOB China USD/kg**

### 21.2.4.13 Yttrium prices

Prices of yttrium metal and oxide experienced great variations from 2010 to 2014. After a sharp increase from 2010 to 2011, from USD 10 per kg in 2008-2009 to an all-time high of USD 180 per kg in July 2011, prices of Y metal went down to reach a relatively stable value of around USD 30 per kg in 2019 (BRGM, 2015).



**Figure 382: Annual average prices of 99% yttrium oxide in USD/kg from 2005 to 2019 (FOB China, DERA 2019)**



**Figure 383: Y oxide 99% (left) and metal (right) price. Data from DERA 2019 99% FOB China USD/kg**

## 21.3 EU demand

### 21.3.1 EU demand and consumption

The EU consumption of REE is 4,734 t/y of compounds (expressed in REO content) and 683 t/y of REE metals and interalloys during the 2016-2018 period and is entirely based on imports, which amount to 9,438 t/y for the REO compounds and 1,162 t/y of REE metals and interalloys<sup>227</sup>. Consumption of individual REE is presented in Table 150.

**Table 150: EU consumption of individual REE (Eurostat, 2019; Guyonnet et al., 2015; Bio Intelligence Service, 2015).**

REE consumed by the EU		Compounds [t]	Metals and Inter alloys [t]
LREE	Ce	3,722	305
	Nd	61	39
	La	394	251
	Pr	25	16
	Sm	4	2
	tot LREE	4,206	613
HREE	Eu	21	3
	Tb	21	3
	Gd	10	1
	Er	8	1
	Dy	12	2
	Y	450	59
	Ho, Tm, Lu, Yb	8	1
	tot HREE	529	70
<b>Total</b>		<b>4,734</b>	<b>683</b>

<sup>227</sup> UNCOM data shows EU-28 imported – 12,508 tons of RE compounds and oxides and 882 tons of metals and alloys

*"The REE-consuming sectors demand specific type and quality of the REE-products to fit to their needs; e.g. some sectors will need REO or REE carbonate, whilst other sectors demand high purity of REE metal. Thus a wide range of REE-products are produced, tailored to each of the sectors and sub-sectors; the vast majority of these products are manufactured in China" (Machacek and Kalvig 2017: EURARE).*

*"Purity is the main quality parameter applied for measuring the REE-products. The purity refers to the relative, thus proportional, maximization of some elements in the final REE-products as compared to the others. In other words, the product CeO<sub>2</sub>, for example, could have a purity of 99.9% (see for instance Panadyne Abrasives, 2012-2016), or in industry jargon 'three N' or '3N'. This explains that the cerium oxide contains 99.9% cerium, yet traces of the other REE are still present which jointly account for 0.1%" (Machacek and Kalvig 2017: EURARE).*

*"The configuration of the REE chemical separation plant is engineered to match specific purity levels defined by the industrial user, and the processes occurring during the chemical separation are therefore tightly controlled. Commonly, the client will test the REE-product in a qualification process that can take from a few weeks up to a year (Mintek, 2013; Lynas Annual Report, 2013). As a general rule, high-N products are orders of magnitude more expensive as opposed to low-N products. Consumers therefore try to find the adequate balance between price and quality" (Machacek and Kalvig 2017: EURARE).*

*"The aim of maximizing purity of REOs is to reach the specifications set out by the intermediate industrial users of these separated REE, e.g. purity levels in the range of 99 to 99.9999%, depending on intermediate industry requirements (Leveque, 2014). For instance, firms which produce fluorescent lamp bulbs and use REE-phosphor-based powders to coat the bulbs demand purities of up to 99.9999%, as the purity of the specific REE (Eu, Tb, Y) affects whether the bulb will be able to meet the light spectra it should be showing" (Machacek and Kalvig 2017: EURARE).*

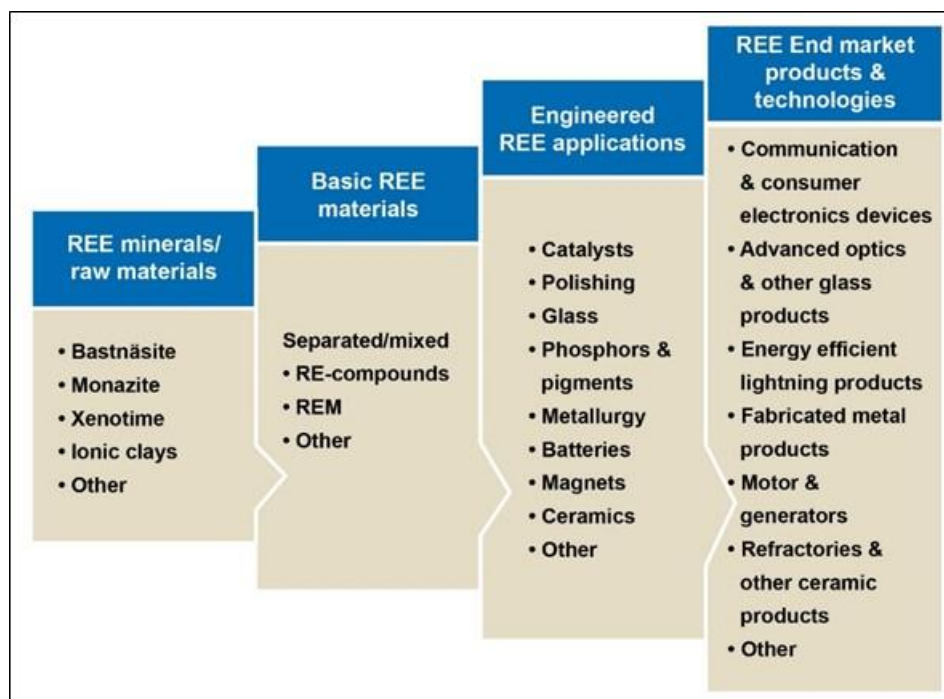
*"The downstream segments of the filament of REE-based permanent magnets require several processing steps to obtain the material magnet producers require as input. The first segment in this REE-permanent magnet manufacturing process sequence is metal making. The individual REO are fed into the process which can involve amongst others molten salt electrolysis and electrolysis of REE-bearing ionic liquids, producing high purity REM, such as Nd metal, or alloys of REE, such as mischmetal (La-Ce; La-Ce-Pr; or La-Ce-Pr-Nd) used in the iron and steel industry and in the production of La-rich battery alloys (Kingsnorth, 2014), lighter flints or ferro-alloys (GWMG, 2012 and Roskill, 2011)" (Machacek and Kalvig 2017: EURARE).*

*"Didymium, a mixture of the elements praseodymium and neodymium, can be a further output of the metal making process which is supplied to magnet alloy producers. Residues such as SEG (Sm-Eu-Gd) and the heavier fractions are sold on for further separation (Roskill, 2011). High purity REE-metals and other metals are then used to produce specialist alloys, or so-called "super alloys" of aluminium or permanent magnet alloys such as NdFeB or SmCo (Roskill, 2011)" (Machacek and Kalvig 2017: EURARE).*

### **21.3.2 Uses and end-uses in the EU**

Figure 384 illustrates a general REE value chain from mineral raw materials, REE- salts, - compounds and -metal alloys up to final goods and services deployed on the market,

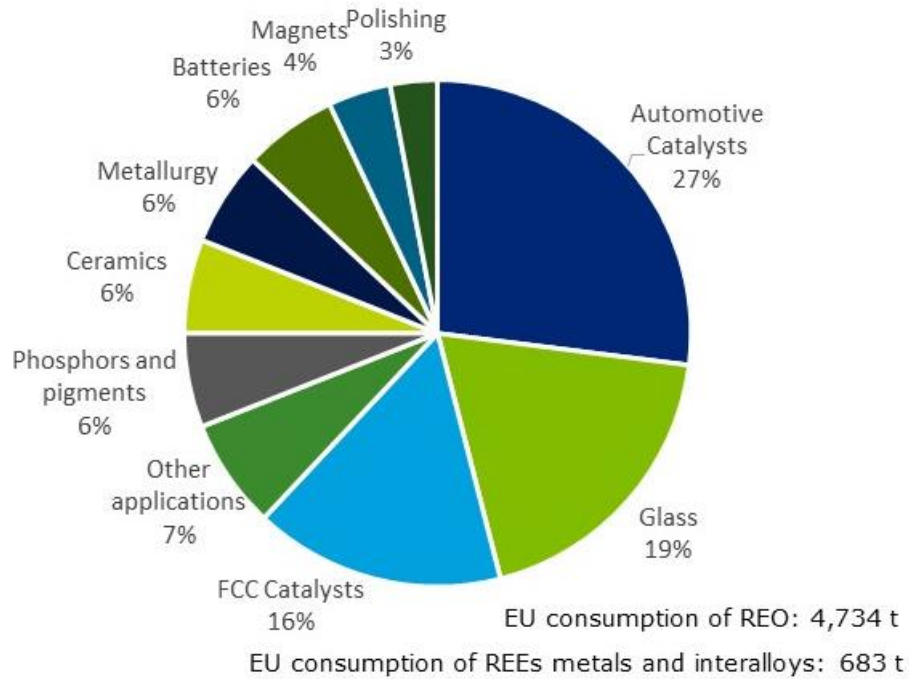
including the production of REE salts and compounds and the manufacture of intermediate engineered products (catalysts, magnets, glass and ceramics, metallurgy and batteries, lighting, electric and other light vehicles, appliances and consumer electronics, communication devices, defence technologies, chemicals, oil refining, electric power, health care products and other final goods and services).



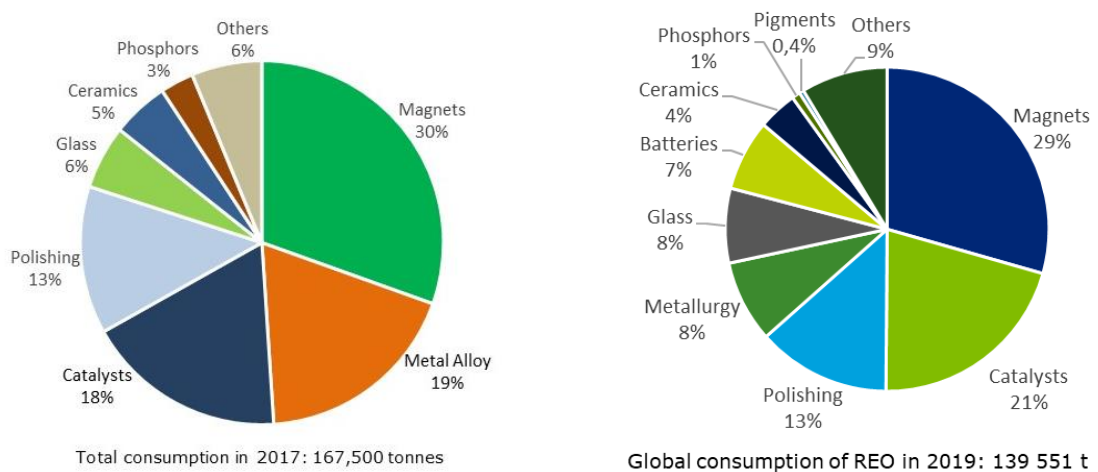
**Figure 384: Simplified REE value chain from mineral raw materials up to end-products and technologies (Machacek and Kalvig 2017: EURARE).**

The major applications vary according to individual Rare Earth Elements, but also regionally. Overall, the EU global consumption of REE by end-use is the presented in Figure 385 (expressed in tonne). The repartition of end-uses is different in the EU compared to the global situation (see Figure 386), with a higher use of REE in catalysts

in the EU, whereas REE are by far less used in magnets.



**Figure 385: EU end uses of REEs and EU consumption, average 2016-2018 (EURARE, 2017; Eurostat Comext, 2019)**



**Figure 386: Global end uses and consumption (Left in 2017: Kingsnorth, 2018. Right in 2019: Eurostat, 2019; Machacek and Kalvig 2017: EURARE; Roskill 2019))**

Globally, the main markets for most abundant rare earths - lanthanum and cerium are in catalysts (both fluid catalytic cracking and car catalysts) and in glass. The main markets for praseodymium, neodymium dysprosium, samarium and gadolinium are in magnets. Europium, terbium, and yttrium are mainly used in lighting phosphors. Glass is the main application of erbium and holmium/lutetium/ytterbium/thulium; and ceramics of yttrium.

**Table 151: Applications of the REE (Data from the ASTER project – Guyonnet et al., 2015, and Average figures for 2016-2018 Eurostat, 2019)**

Applications	Heavy REE	Light REE
--------------	-----------	-----------



	Eu	Tb	Gd	Er	Dy	Y	Ho, Tm, Lu, Yb	Ce	Nd	La	Pr	Sm
Magnets	-	32%	<b>97%</b>	-	<b>100%</b>	-	-	-	<b>37%</b>	-	<b>24%</b>	<b>97%</b>
Metal	-	-	-	-	-	-	-	6%	12%	3%	11%	-
Batteries	-	-	-	-	-	7%	-	6%	13%	10%	12%	-
FC Cracking	-	-	-	-	-	-	-	8%	-	<b>67%</b>	-	-
Car catalysts	-	-	-	-	-	-	-	<b>35%</b>	6%	-	10%	-
Polishing	-	-	-	-	-	-	-	11%	-	5%	10%	-
Glass	-	-	-	<b>74%</b>	-	4%	<b>100%</b>	<b>31%</b>	8%	10%	8%	-
Phosphors	<b>96%</b>	<b>68%</b>	-	26%	-	<b>46%</b>	-	1%	-	2%	-	-
Ceramics	-	-	-	-	-	<b>35%</b>	-	2%	11%	2%	15%	-
Others	4%	-	3%	-	-	8%	-	-	10%	-	10%	3%
<b>Total use in EU (t)</b>	<b>23</b>	<b>23</b>	<b>12</b>	<b>9</b>	<b>14</b>	<b>509</b>	<b>9</b>	<b>4026</b>	<b>101</b>	<b>644</b>	<b>41</b>	<b>6</b>

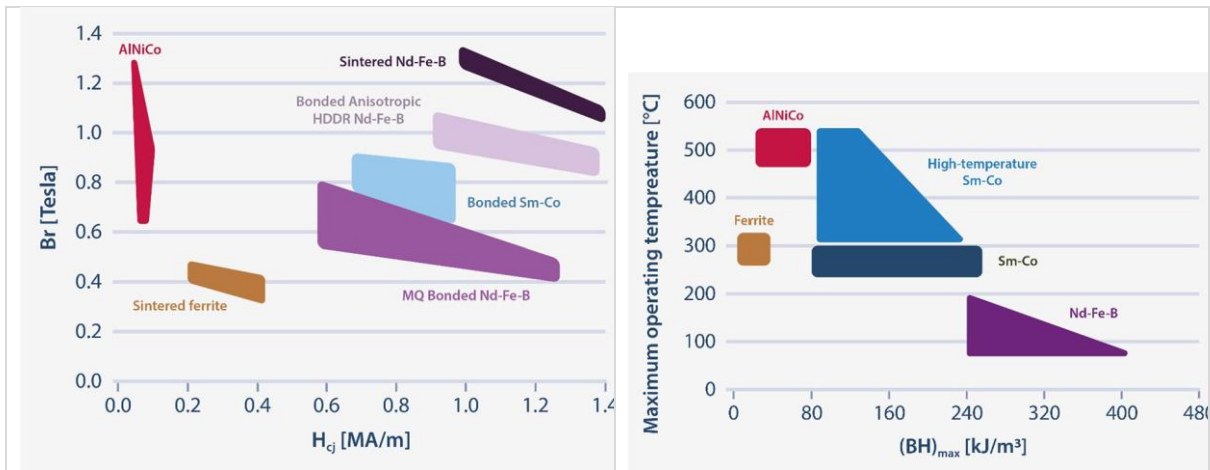
The following chapters based on substantial input from Machacek and Kalvig 2017: EURARE provide more details about individual applications.

### 21.3.2.1 Magnets, electric motors and generators

Permanent magnets are materials, which are able to retain magnetic properties after inserted in a strong magnetic field, also once that the external magnetic field expires. There are different characteristics which make magnets suitable for different applications, such as magnetic strength, resistance to demagnetisation, higher temperatures, chemical corrosion, relative density etc.

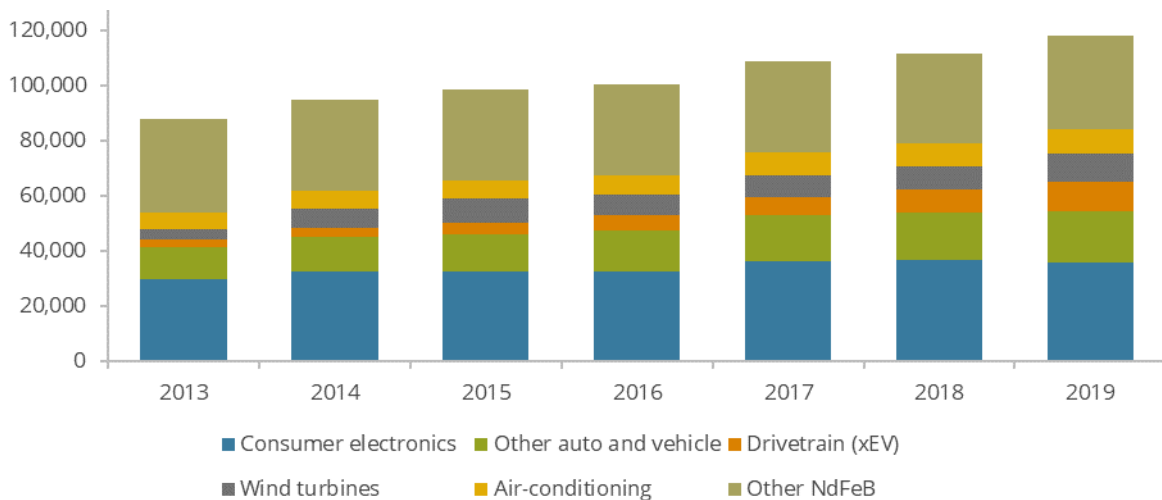
*"Permanent magnets have a variety of uses, and are e.g. used in the following major groups: acoustic transducers, motors and generators, magneto mechanical devices, and magnetic field and imaging systems. In cars, magnets are being utilized in permanent magnet motors, controlling the power window, windshield wipers, and used for generators, as well as utilized in various types of sensors. Also magnets are used in amplifiers and loudspeakers, smartphones and other communication technology. The wind-turbine sector is a major consumer of permanent magnets. In addition, an emerging technology using REE-magnets, i.e. magnetic refrigeration, could potentially improve the energy efficiency of refrigerators for home and commercial use"* (Machacek and Kalvig 2017: EURARE).

The most important REE for permanent magnets are neodymium, praseodymium, dysprosium, samarium and also other REE used in minor amounts. NdFeB magnets are the strongest known types of permanent magnets were invented in the 1980s by General Motors Corporation, US and Sumitomo Special Metals, Japan. A NdFeB magnet can lift 1300 times its own mass. NdFeB alloyed with up to 4 wt% dysprosium can dramatically increase the maximum operating temperature from 80°C up to 200 °C.



**Figure 387: (left) Comparison of the properties of different types of magnets. Br = remanence (magnetization left after an external magnetic field is removed); H<sub>cj</sub> = coercivity (a measure of the resistance of a ferromagnetic material to becoming demagnetized) (Binnemans 2018). (right) Comparison of the maximum operating temperatures of NdFeB and Sm-Co magnets (Binnemans 2018).**

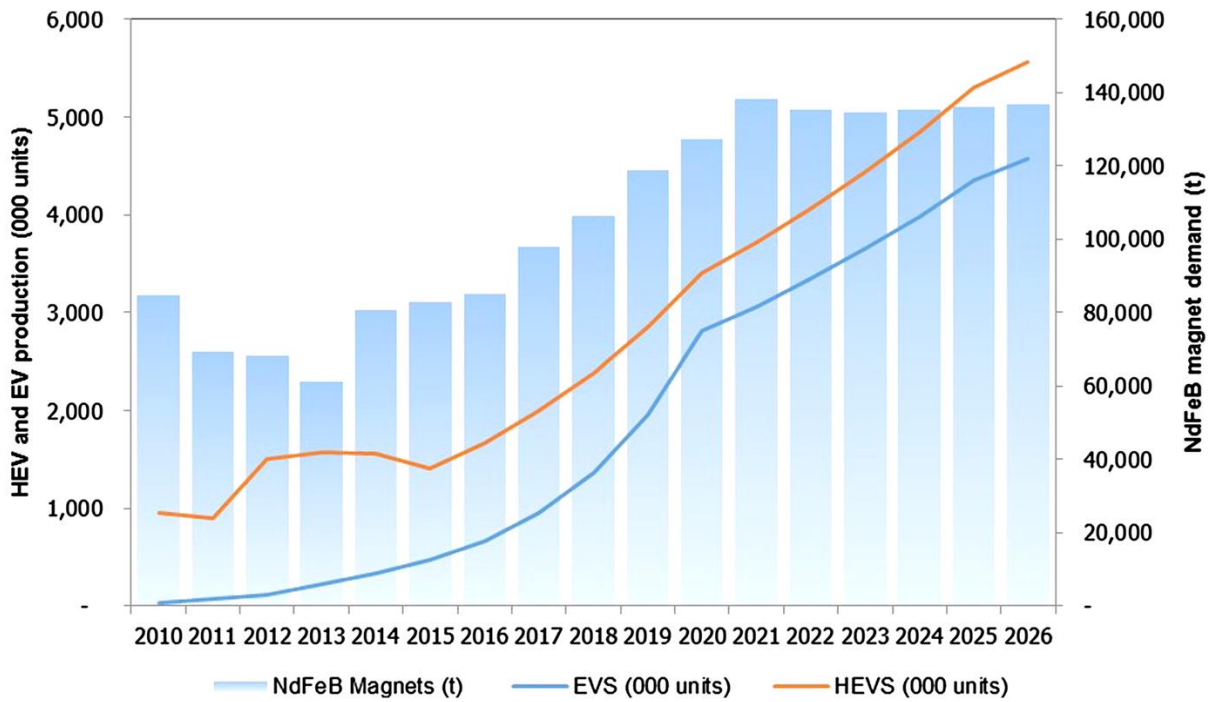
Global production of NdFeB magnets is around 80,000 tpa (Binnemans 2015) worth USD 13.4 billion in 2015 (Global Information Inc. 2016), representing around 66% of the market value (Global Market Insights Inc., 2017). Although ferrites remain the most used raw material for permanent magnets (in 2012 they accounted for about 80% of the global permanent magnets production) (Grand View Research, 2014), mainly because they are cheap and largely used in the fast growing automotive market. Minor production shares then relates to AlNiCo and SmCo magnets (around 1,000 tpa) (Binnemans 2015).



**Figure 388: NdFeB magnets demand per application in tonnes in 2013-2019 (Roskill 2019)**

### Electric motors

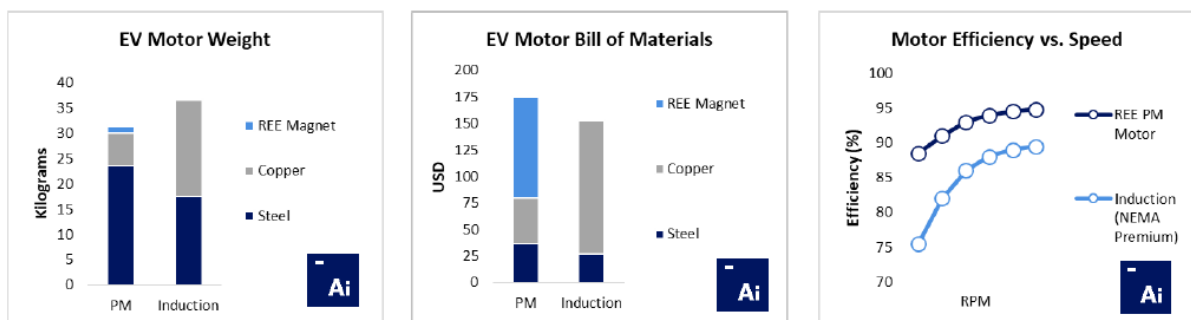
In the next decade, the most disruptive technology for the consumption of REE is forecast to be the growth in hybrid electric vehicles (HEVs) and full electric vehicles (EVs), which are expected to cause wholesale changes in the volumes and types of raw materials consumed by the automotive industry. Production of HEVs and EVs is forecast to increase from 2.3 million units in 2016 to over 10.1 million units in 2026 (Roskill 2016a), as nearly all major automotive manufactures have developed HEV and EV models.



**Figure 389: Forecast production of HEVs and EVs versus NdFeB magnet demand, 2010–2026. (Goodenough et al. 2017).**

Hybrid electric vehicles (HEVs), plug-in hybrids (PHEVs), and pure electric vehicles (EVs) all require electric motors.

In 2018, 93% of all passenger EVs sold globally used permanent magnet traction motors (PMSM) containing rare earth permanent magnets (e.g. in BMW i3). Permanent magnet synchronous motors are up to 15% more efficient than induction motors and are the most power-dense type of traction motor commercially available (in kW/kg and kW/cm<sup>3</sup>). Other rare earths free alternatives are induction motors (IM) (used in Tesla model S or Renault Twizy), and electrically-excited synchronous motors (EESM) (used in Renault Zoe and Fluence, or Smart Fortwo).



**Figure 390: Comparison of EV traction motor weights, costs and efficiencies (UBS, Control Engineering in Adamas Intelligence, 2019)**

A high-performance magnet for use in motor applications has a composition close to 31%Nd–4.5%Dy–2%Co–61.5%Fe–1%B (wt%). The dysprosium is critical in this application to provide very high coercivities in order to achieve a service temperature of 160 °C.

Hybrid EVs and pure battery EVs use between 1-3kg of neodymium-iron-boron (NdFeB) magnets in standard drivetrain motors<sup>228</sup>. Binnemans (2018) states that for a 55-kW motor, 0.65 kg of Nd-Dy-Co-Fe-B alloy is required, which represents 200 g of neodymium (3.6 g/kW) and 30 g of dysprosium (0.55 g/kW) per motor.

Adamas Intelligence (2019) assumes that to produce 1.6 kg of NdFeB alloy requires approximately 0.5 kg of rare earth metal inputs (primarily NdPr with lesser Dy and minor Tb), plus an additional 15 to 20% to compensate for losses incurred during production of NdPr metal and Ferro-Dy alloy input materials, bringing total consumption to approximately 0.6 kg of rare earth metals per 100 kW of peak motor power (6 g/kW).

	Material Intensity (Per 100 kW) *	Avg. EV Motor in 2018 (93 kW)	Avg. EV Motor in 2025 (131 kW)
<b>NdFeB</b>	1.6 kg	1.5 kg	2.0 kg
<b>NdPr metal</b>	0.6 kg	0.5 kg	0.8 kg
<b>NdPr oxide</b>	0.7 kg	0.7 kg	1.0 kg

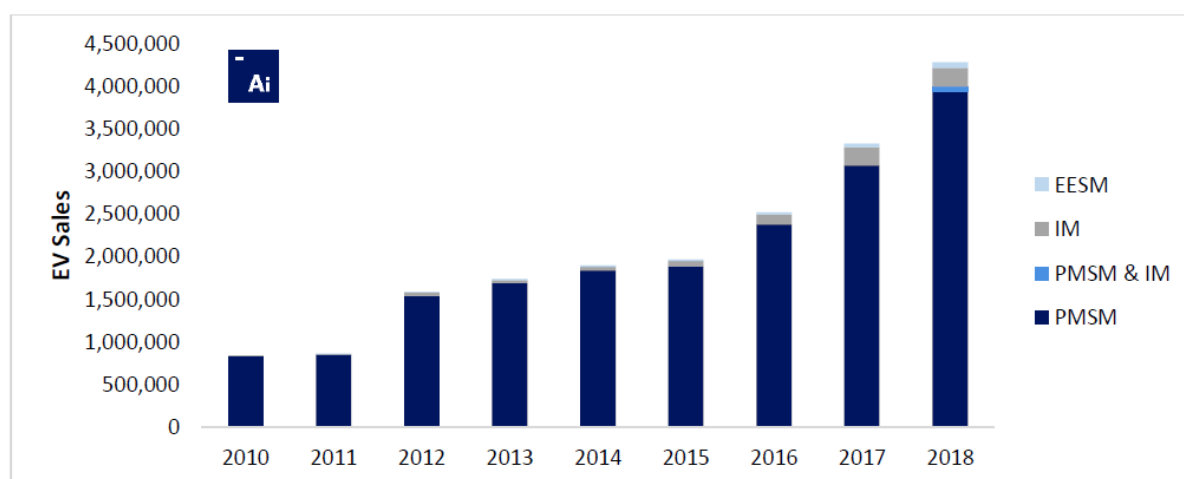
\* Magnet, metal and oxide mass estimates account for material losses from oxide to metal to alloy to finished NdFeB

\* Numbers may not calculate exactly as shown due to rounding

Source: Adamas Intelligence research

**Figure 391: Rare earths materials used in a permanent magnet traction motor. (Adamas Intelligence 2019).**

The global electric car fleet exceeded 5.1 million in 2018<sup>229</sup>, up by 2 million since 2017, almost doubling the unprecedented amount of new registrations in 2017. China remained the world’s largest electric car market with nearly 1.1 million electric cars sold in 2018 and, with 2.3 million units, it accounted for almost half of the global electric car stock. Europe followed with 1.2 million electric cars and the United States with 1.1 million on the road by the end of 2018 and market growth of 385 000 and 361 000 electric cars from the previous year. Norway remained the global leader in terms of electric car market share at 46% of its new electric car sales in 2018, more than double the second-largest market share in Iceland at 17% and six-times higher than the third-highest Sweden at 8%.

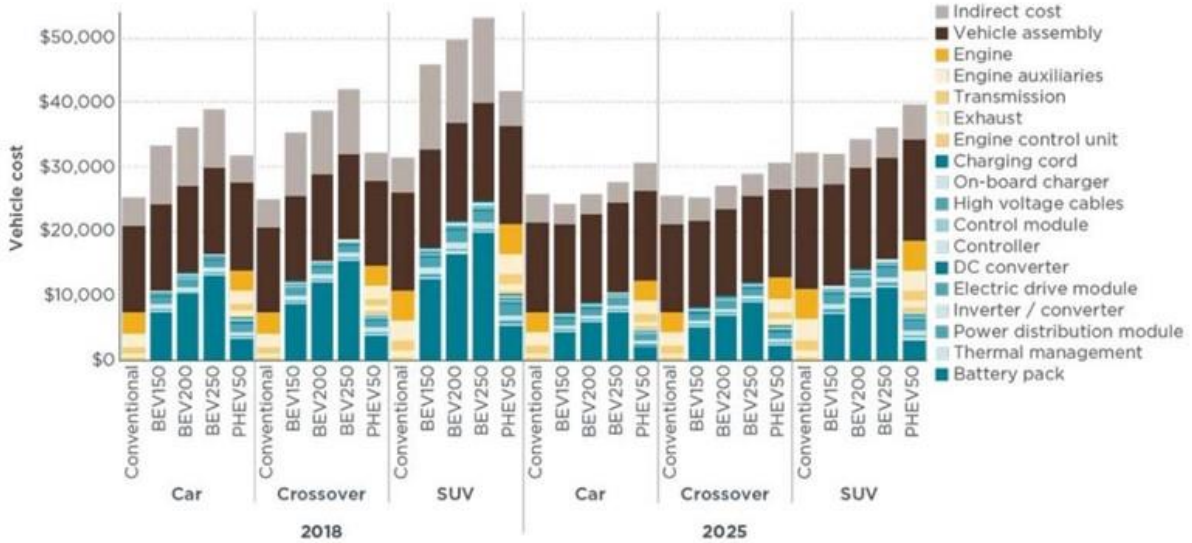


**Figure 392: Global sales of electric vehicles 2010-2018 (Adamas Intelligence, 2019). Permanent magnet synchronous motors (“PMSMs”), induction motors (“IMs”), and electrically-excited synchronous motors (“EESMs”). Of the three**

<sup>228</sup> <https://roskill.com/news/rare-earths-bmw-fifth-generation-ree-free-electric-drivetrain/> posted on 4 January 2019

<sup>229</sup> <https://www.iea.org/publications/reports/globalevoutlook2019/>

**motor types, PMSMs are the only variety that contain rare earth permanent magnets.**



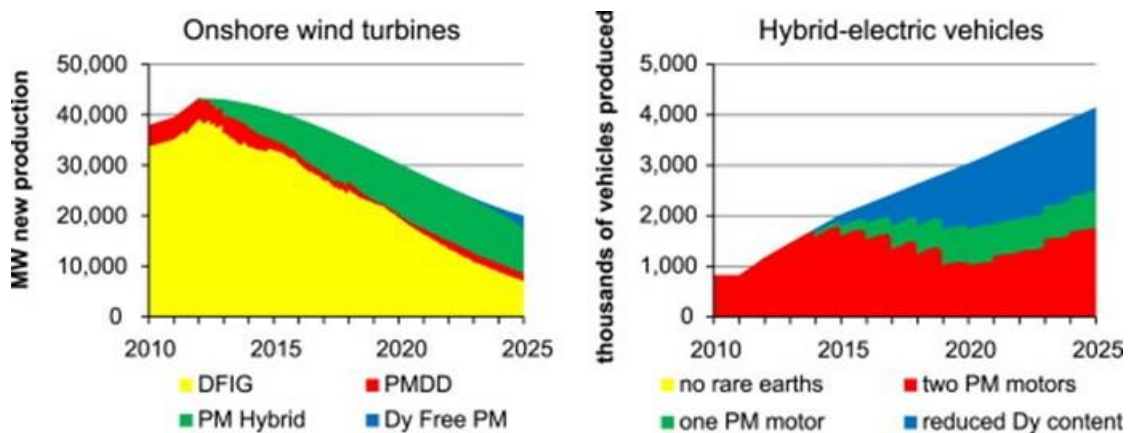
**Figure 393: Vehicle technology costs for conventional and electric vehicles in 2018 and 2025 for cars, crossovers and SUVs (ICCT)<sup>230</sup>**

A new and rapidly growing market for NdFeB magnets is electric bicycles, which contain lightweight, compact, Nd-Fe-B-based, miniature electric motors. They use approximately 350 g of NdFeB or 86 g of neodymium per electric bicycle. So far, there are no alternatives to NdFeB magnets in bicycles due to space and weight considerations. (Binnemans 2018)

*Electricity generators*

Wind turbine producers choose between doubly fed induction generator (DFIG) turbines, which require no permanent magnets (PMs); direct-drive turbines, which require large NdFeB PMs; hybrid drive turbines, which require smaller PMs; and turbines that use large PMs, but require no Dy, as high temperatures are unlikely to occur in a well-designed wind turbine.

Direct-drive wind turbines contain 700–1200 kg of NdFeB magnets per MW, which corresponds to 175–420 kg of pure neodymium per MW.



**Figure 394: Production of onshore wind turbines and hybrid electric vehicles using different technologies: average baseline scenario projections. (Notes:**

<sup>230</sup> <https://thedriven.io/2019/04/04/electric-cars-could-cost-half-of-equivalent-petrol-vehicles-by-2030/> posted on 4 April 2019

**DFIG=doubly-fed induction generator, PMDD=permanent magnet direct drive, and PM=permanent magnet) (Riddle et al. 2015).**

Europe installed 11.7 GW (10.1 GW in the EU) of gross power capacity in 2018<sup>231</sup>, which was 33% less than in 2017. With a total net installed capacity of 189 GW, wind energy remains the second largest form of power generation capacity in Europe, set to overtake gas installations in 2019.

In November 2018<sup>232</sup>, a 3.6MW wind turbine in Denmark had its permanent magnet generator replaced by a high-temperature superconductor (HTS) based generator as part of the EU-funded EcoSwing project. The superconductor reduces the size of the generator and replaces about 1t of neodymium (Nd) used in NdFeB permanent magnets with about 1kg of the rare earth gadolinium (Gd) used in the superconducting composite tape: gadolinium–barium–copper oxide (GdBaCuO).

### **21.3.2.2 Metallurgy**

*“REE are used in the manufacture of iron and steel to improve performances and properties of the final products. Among their different applications in metallurgical industry, REE are employed in construction and automotive sector, including Hybrid Electric Vehicles (HEV) and Electric Vehicles (EV), in portable electronics, in fuel cell components, in high strength metals for aircraft manufacture and in magnesium alloys” (Machacek and Kalvig 2017: EURARE).*

*“Ce and La are by far the most used REE in this field. In metallurgical applications REE are usually applied as mischmetal or as REE-silicide. Mischmetal is an alloy made by a mixture of REE obtained by an electrolytic extraction; although different composition are available on the market based on Ce content, a typical mischmetal composition is: 48-56% Ce, 25-34% La, 11-17% Nd, 4-7% Pr, minor amounts of other REE, 0.2-0.5% Fe and other impurities such as Si, Mg, S and P (MSE Supplies LLC, 2017; Metall Rare Earth Ltd, 2017). REE-silicide, which is usually less reactive than mischmetal, is instead constituted by REE, silicon and iron in about equal proportions” (Machacek and Kalvig 2017: EURARE).*

*“In particular, the overall amount of REE (mischmetal or REE-silicides) used to remove impurities in iron and steel casting have partially declined, due to the shift by foundries in Europe and North- America to magnesium ferrosilicon (FeSiMg) nodulisers containing much smaller amounts of REE. Moreover, the employment of Ce to remove traces of sulphur from the molten materials, typically after deoxidation and desulphurisation stages, or to improve the mechanical properties (e.g. corrosion resistance) of the final product is decreasing. REE are where possible substituted by less expensive metals such as magnesium, calcium and other Group II metals are commonly used for such purposes. Information about purity is based on American Elements and Metall Rare Earth Ltd.” (Machacek and Kalvig 2017: EURARE).*

### **21.3.2.3 Batteries**

*“Nickel-metal hydride (NiMH) batteries were introduced to the market in the 1990’s, as an improvement of the existing nickel hydrogen technology, mainly based on nickel-cadmium (NiCd) batteries. Both are rechargeable batteries with almost similar electrochemical*

---

<sup>231</sup> <https://windeurope.org/about-wind/statistics/european/wind-energy-in-europe-in-2018/>

<sup>232</sup> <https://roskill.com/news/rare-earths-ndfeb-wind-turbine-generator-replaced-by-high-temperature-superconductor/>

behaviour. But the NiMH batteries have better performances due to longer life-cycle, higher stability and lack of persistence issues. Moreover, the Cd-anode in the Ni-Cd-battery is replaced with a metal hydride in the NiMH battery, making the latter 'greener'. Due to such enhancements, NiMH batteries have been increasingly deployed in different growing markets (e.g. portable tools and consumer electronic applications), even if their largest use is in the emerging sector of HEVs.

In the last years, the employment of REE, such as La-rich mischmetal, in the manufacture of NiMH to be included in the anode formulation of rechargeable batteries has increased. Within a typical NiMH battery, metal components represent more than 60% of the battery weight, of which Ni, Fe, Co and REE account for about 18%, 15%, 4% and 17% respectively (Lin et al., 2015). La is the most employed REE within NiMH batteries, followed by Ce, Pr and Nd.

Lithium-ion (Li-ion) batteries are increasingly replacing NiMH batteries in computing, communication and consumer products (e.g. mobile phones and laptops) due to their easier manufacture in special shapes: indeed, electronics covers about 50% of the global market associated to lithium-ion batteries (Allied Market Research, 2016).

Although the manufacturing costs of Li-ion are still higher than the ones associated to NiMH batteries, Li-ion batteries are partially replacing NiMH batteries also in PHEVs and EVs, mainly because of their higher energy density and longer lifespan. Indeed, such types of electric vehicles can be charged by plugging them in a grid-provided electricity system and thus require batteries with higher energy density in order to guarantee a range as wide as possible between charging stations. The battery for HEVs are charged through the gasoline combustion engine, and for this purpose the high-power density NiMH batteries are more suited, and therefore still represent the most used batteries in HEVs, although in 2013 lithium-ion batteries accounted for about 20% of all batteries used in HEVs (CEC, 2015). However, NiMH batteries maintain a relevant role in large-size, stationary applications in which power-to-weight is less important (e.g. back-up units), as well as in high-temperature applications where Li-ion batteries are unsafe. China currently leads the production of small-size NiMH batteries, while the large-size ones are mainly manufactured in Japan. Information about purity is based on American Elements and Metall Rare Earth Ltd". (Machacek and Kalvig 2017: EURARE).

#### **21.3.2.4 Catalysts**

"Catalysts are substances used to increase the rate of a chemical reaction by reducing the activation energy, i.e. the energy required by the system in order to convert the reactants into the products. Catalysts do not actively participate to the reaction; they are modified or consumed only in very minor quantities during the reaction itself.

The two main areas of applications for REE in the catalysis sector are associated to the formulation of catalysts for the Fluid Catalytic Cracking (FCC) in the petroleum processing, as well as in catalysts aiming at reducing emissions of pollutants within the exhaust gases originated from automobiles and other combustible engines. Several of the REE are used in catalysts formulation, both in processing and in automotive applications: they are mainly La, Ce, Nd and Pr. Information about purity is based on American Elements and Metall Rare Earth Ltd." (Machacek and Kalvig 2017: EURARE).

##### *Fluid Catalytic Cracking (FCC) catalysts*

"FCC process is used in the petroleum industry to obtain light fractions such as LPG and gasoline from high-molecular weight hydrocarbon fractions. Due to the higher octane

rating of gasoline and higher yield in olefinic gases, this process has gradually substituted the thermal cracking. In particular, the employment of La, Ce and Nd rose in the 1960s, when zeolite-based cracking catalysts started to be used in oil refineries. These kinds of catalysts are typically constituted by a crystalline zeolite (representing 5-40% of the catalyst weight), i.e. the active component acting as a sieve to filter the crude oil, by a matrix typically of alumina (5-25 wt%), by a binder such as silica sol or gel (5-25 wt%) and by an inert matrix, i.e. the clay (Trigueiro et al., 2013; Henriques, 2012; Roskill, 2016)". (Machacek and Kalvig 2017: EURARE).

#### Car catalysts

"Along with applications in petroleum processing, catalysts for automotive engineering represent another large market for REO, aiming at reducing emissions of pollutants within the exhaust gases originated from automobiles and other combustible engines. In particular, Ce, La, Nd and mainly REO and RE-compounds are used; dominant purity specifications are 3-4Ns and 2-5Ns respectively. CeO<sub>2</sub> or other Ce-compounds are used to (i) keep up the catalysts efficiency by avoiding the formation alpha alumina phase; (ii) improve the oxidant features of the overall system and facilitates a water-gas shift on reaction." (Machacek and Kalvig 2017: EURARE).

"The amount of REE required for automotive catalysts' formulation depends on vehicle type (petrol, diesel or hybrid vehicle) and size. China is currently leading the worldwide vehicle markets (in 2015 it accounted for about 27% of the global production) (OICA, 2015). In addition, the demand for automotive catalysts is further affected by the fact that, unlike European customers, Chinese customers usually prefer large-size vehicles (e.g. SUVs), entailing major amounts of catalysts (Roskill, 2016). The automotive sector is influenced by changes in emissions standards: even though European regulations are more stringent, USA and BRIC countries are fostering a tighter emission control (e.g. India's and China's emission standards are now respectively equivalent to the ones of Euro III and Euro IV), thus offering opportunities for REE (mainly Ce) to be used in catalysts." (Machacek and Kalvig 2017: EURARE). Information about purity is based on American Elements and Metall Rare Earth Ltd.

#### 21.3.2.5 Polishing

"REE-based polishing powders are essentially employed to finish the surface of glass products and electrical components, such as display panels, flat glass, optical glass and consumer electronics. Moreover, REE (i.e. CeO<sub>2</sub>) can also be used in jewellery as alternative to jeweller's rouge, i.e. a very fine powder of ferric oxide, to polish precious metals and stones (Roskill, 2016).

Although CeO<sub>2</sub> is the most used REE compound, polishing powders can also contain traces of other REE with minor polishing properties (i.e. La, Pr, Nd). The main advantages in using CeO<sub>2</sub>-based polishes, making them the most used glass polishes, are related to the faster polishing operations, in which CeO<sub>2</sub> is mixed with water, and easier cleaning after use. In particular, most of the Ce is employed in traditional glass polishing applications (e.g. display panels, flat glass and optical glass, silicon microprocessors and disk drives), while the rest of the Ce is used in consumer electronics.

The global economic downturn in 2009 and the later increased prices of Ce in 2011 significantly affected the overall market of REE for polishing applications, which constantly had increased during the previous years, following the demand for polished glass and glass-like components in consumer electronics and optical products.



High prices in 2011 reinforced the role of China as the worldwide larger producer of Ce polishing powders, also considering its dominance in manufacturing of glass products and electrical components. Research activities are being carried out in China to improve the quality of polishing powders based on CeO<sub>2</sub>, in particular by applying the CMP (i.e. Chemical Mechanical Planarisation) method to obtain higher grades powders for the polishing of electronic components (Roskill, 2016).

The price spike in 2011 boosted the industrial research both for improved technical solutions enabling the reduction of Ce use, as well as for alternative materials such as zirconia (especially for lower quality products). However, as price decreased again, these efforts to find substitutes were put on hold and the traditional use of CeO<sub>2</sub> were maintained.

Within the same approach, polishing industry developed solutions enabling the recovery and re-use of slurries from polishing operations: this led to the implementation of recycling steps within several polishing plants. Information about purity is based on American Elements and Metall Rare Earth Ltd.” (Machacek and Kalvig 2017: EURARE)

#### **21.3.2.6 Glass**

“REE are used to provide specific properties to several kinds of glass for different purposes, from display panels to specialty optical glasses: they can act as colouring agents, as protective agents against different kinds of radiation (e.g. infrared, X-ray, UV), or can be used to remove impurities from glass, thus acting as decolouring agents.

Ce is the dominant REE used in this sector, though also La, Er and minor amounts of Gd, Nd, and Y are also employed in different technological applications within the glass sector. Moreover, small quantities of other REE can be used: they include Pr, Sm, Eu, Ho and Tm.

Ce is utilised as a glass stabiliser to contrast effects of UV and high-energy rays (for example in display panels and in the bottling industry) or as decolouring agent to remove natural impurities from glass, such as iron oxides. In particular, a specific market for CeO<sub>2</sub> exists in Japan, where UV-resistant glass for vehicles is required by legislation to be used in vehicle front windscreens.

Presently, display screens account for most of the demand for REE-glass additives, while the rest of the REE demand in glass sector is mainly covered by optical glass.

USA represents the principal market for glass coating based on REE (e.g. used in scientific lenses, laser cavity mirrors, laser printer mirrors, slides for electron microscopy) mainly related to the defence sector. For glass coating, only high purity 4N-products of CeO<sub>2</sub>, Ce-fluoride, La<sub>2</sub>O<sub>3</sub> and Nd-fluoride, with addition of iron oxide, can be employed (Roskill, 2016). Information about purity is based on American Elements and Metall Rare Earth Ltd.” (Machacek and Kalvig 2017: EURARE)

#### **21.3.2.7 Phosphors**

“Phosphors are defined as “optical transducers providing luminescence” (Rare Earth Technology Alliance, 2014). Within the phosphors, activators determine the emission spectra while hosts convert the energy gathered by the phosphors into radiant energy (light). REE in the phosphors sub-sector are employed as doping elements, activators and in the host mixtures.

Y<sub>2</sub>O<sub>3</sub> is by far the most used REO in phosphors, followed by Pr<sub>6</sub>O<sub>11</sub>, CeO<sub>2</sub>, La<sub>2</sub>O<sub>3</sub> and Eu<sub>2</sub>O<sub>3</sub>. However, the type of REE to be used in phosphors, their relative composition and content are dependent on the specific application and are typically considered proprietary

information. Generally, the oxides of Y, Gd, and La are mainly employed as host materials in phosphor production. Several other REE find application in the phosphor sector primarily as activators, with a relevant role covered by Eu-activated red phosphors. Eu is widely used in TV and PC monitor screen panels and to a lesser extent in lighting and medical imaging, such as X-ray. Information about purity is based on American Elements and Metall Rare Earth Ltd." (Machacek and Kalvig 2017: EURARE)

#### **21.3.2.8 Ceramics**

"REE-elements are employed in the ceramic intermediate sectors as rawmaterial in the following three sub-sectors of the manufacturing of ceramic products: (i) refractories, (ii) electronic ceramics, and (iii) engineering ceramics. Beside Y, which is the most important REE for this sector, Nd, Ce, La and Pr are mainly employed. In particular, high-grade  $Y_2O_3$  with minimum purity of 99.999% (5N) is often required for ceramics applications (Rare Earth Technology Alliance, 2014). For example,  $Y_2O_3$  is used (from 3 mol% to 8 mol%) (Inframat Advanced Materials, 2017) as stabiliser in yttria-stabilised zirconia (YSZ) or partially stabilised zirconia (PSZ) formulation; YSZ is employed, among others, in fuel cells components, in  $O_2$  sensors, in fibre-optic connectors, as thermal barriers in jet engines, for automotive fuel control, in dental applications. Information about purity is based on American Elements and Metall Rare Earth Ltd."

Around 0.4% of REE are used as pigments to stain ceramic tiles and to impart colour/improve the finish of ceramic glazes (Roskill, 2016).

Given the wide range of different ceramics products and applications in which REE are involved, including several niche markets, as well as the increasing boost towards the substitution of metals with engineering ceramics, an effective estimation of REE consumption trends for ceramics is quite difficult. However, in the ceramic capacitor-market, for example, base metal (BM) capacitors are gradually replacing precious metal (PM) counterparts, which will reduce the demand for  $Nd_2O_3$  substantially. Information about purity is based on American Elements and Metall Rare Earth Ltd." (Machacek and Kalvig 2017: EURARE)

#### **21.3.2.9 Photonics and 5G**

REE doped laser crystals are used in many applications.

Nd oxide is used as dopant in yttrium aluminum garnet (YAG - neodymium-doped yttrium aluminum garnet;  $Nd:Y_3Al_5O_{12}$ ) lasers to improve absorption and emission performance. Frequently used in material processing and in medical applications. (Machacek and Kalvig 2017: EURARE)

Y and Nd: Used as dopants to cause fluorescence (purity 5N or higher). (Machacek and Kalvig 2017: EURARE)

5G networks would require small cells, rather than geographically dispersed cell towers that characterize LTE networks and its predecessors. 5G communications require a multi Gb/s data transmission in its small cells. For this purpose millimeter wave (mm-wave) radio frequency signals are the best solutions to be utilized for high speed data transmission. Photonic based solutions can generate such signals using REE doped lasers (Er, Th, Yb). (Alavi et al. 2016)

### 21.3.2.10 Other applications

“Minor amounts of REE are applied in other market sectors and products, such as microwave crystals and garnets, nuclear applications, carbon arc lights, textiles additives, medical applications, fertilisers, chemical compounds as reagents or paints drying agents, alloys for magnetic refrigeration, and other. In particular, Ce is largely the most used REE in other applications, followed by La and other minor amounts of Gd, Y, Pr, Nd and other REE. (Machacek and Kalvig 2017: EURARE)

**Table 152: Consumption of REE in miscellaneous sectors (Machacek and Kalvig 2017: EURARE)**

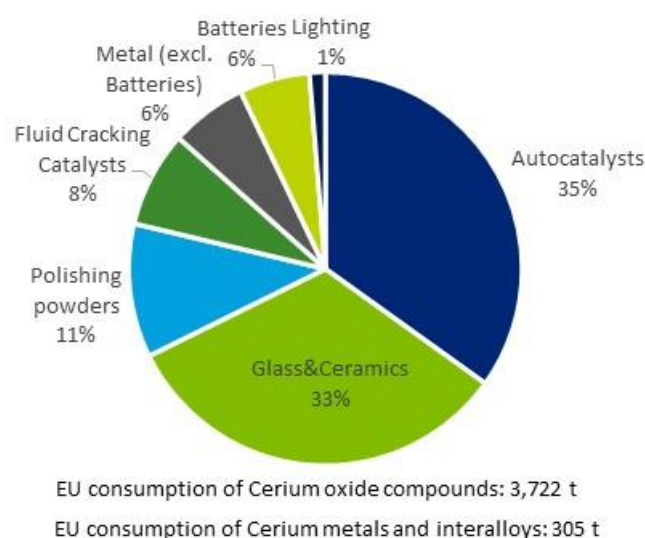
Main area of application	Main RE products	Main uses
<b>Microwave devices</b>	Y, Gd, Nd, Ho, Tm, Er, Yb	Crystals and garnets for microwaves and laser: Y, Gd and Nd. followed by Ho, Tm, Er and Yb compounds as dopant agents. Yttrium-iron-garnet (YIG) used for microwaves and cell phones and laser. Gd-iron-garnet (GIG): Similar applications as above. Y- and Gd-based garnets: used as resonators in frequency meters, magnetic field measurement devices, tuneable transistors, and Gunn oscillators.
<b>Nuclear applications</b>	Gd, Sm, Eu, Dy, Er, Y	Neutron absorbers in nuclear reactors: Frequently used REE are: Gd, Sm, Eu and Dy. Control rods: Sm, Eu, Er and Gd. Shielding purposes and neutron absorbing coatings: Gd and Eu, while Y can be utilised in piping. Detection of radiation leaks: Gd.
<b>Lighting applications</b>	Ce, La, Eu, Pr, Yb	Industrial lighting and projectors: Several LREE-compounds (e.g. Ce, La, Eu, Pr and Yb) are mainly used in these fields, improves the lighting performance, in terms of e.g. quality and intensity. (Rare Earth Technology Alliance, 2014).
<b>Medical applications</b>	Ce, Nd, La, Eu	Drug formulations: e.g. Ce-oxalate in motion sickness drugs, Nd-isonicotinate to treat thrombosis), and in medical applications (e.g. La nitrate used as an antiseptic, Ce-141 used in biological and medical research). Living tissue research: Highly sensitive luminescence is provided by Eu. (Rare Earth Technology Alliance, 2014).
<b>Fertilisers</b>	La, Ce	Fertilizer for cottons and oil-plants in China: REE-oxides added to improve the overall plant growth. Superphosphate: REE compounds are added to calcium superphosphate, thus obtaining a REE-phosphate fertiliser (REPF).
<b>Magnetic refrigeration</b>	Gd, Nd, Tb, Er, La, Pr	Magnetic refrigeration technology: Gd-alloy used as a refrigerant surrounded by NdFeB magnets, which cause the heating and the cooling of the refrigerant itself by respectively increasing and decreasing the magnetic field generated by their movement. Alternative alloys are: e.g. Gd-Si-Ge alloy, Gd-Tb alloy, Gd-Er alloy, La alloys doped with Fe or Pr alloys doped with Ni.
<b>Other applications</b>	Ce, La, Nd, (Pm), Gd, Pr, Ho, Yb	Synthetic gemstones: A niche market for Y. Paint dries: Ce, La and Nd can be included in the formulation. Polymer colorant: Ce sulphide is used in polymer colorants in substitution of Cd compounds. Textiles: Mainly Ce and Pr, are used in textiles as dyes (e.g. Ce compounds), they are mainly used to give “protection” properties (water- or mildew-proof) to the fabric, as well as to face creasing effects or bleaching caused by sunlight; this application is restricted to China.

		Water treatment: Ce and La are also used in the formulation of products for water treatment of pools, spa, municipal and industrial wastewaters, aiming at removing e.g. phosphates.
--	--	--

## 21.3.3 Applications of individual REE

### 21.3.3.1 Cerium applications

The end-use of cerium products in the EU are presented in Figure 395 and relevant industry sectors are described using the NACE sector codes in Table 153.



**Figure 395: EU end-uses of cerium. Average 2016-2018 (Eurostat, 2019a; Guyonnet et al. 2015)**

**Table 153: Cerium applications, 2-digit NACE sectors, 4-digit NACE sectors and value added per sector (Eurostat, 2019c).**

Applications	2-digit sectors	NACE	Value added of NACE 2 sector (millions €)	4-digit NACE sectors
Autocatalysts	C20 - Manufacture of chemicals and chemical products		105,514	C2029 - Manufacture of other chemical products n.e.c.
Glass& Ceramics	C23 - Manufacture of other non-metallic mineral products		57,255	C2310 - Manufacture of glass and glass products
Polishing powders	C26 - Manufacture of computer, electronic and optical products		65,703	C2670 - Manufacture of optical instruments and photographic equipment
Fluid Cracking Catalysts	C19 - Manufacture of coke and refined petroleum products		17,289	C1920 - Manufacture of refined petroleum products
Metal (excl. Batteries)	C24 - Manufacture of basic metals		55,426	C2410 - Manufacture of basic iron and steel and of ferro-alloys
Batteries	C27 - Manufacture of electrical equipment		80,745	C2720 - Manufacture of batteries and accumulators
Lighting	C27 - Manufacture of electrical equipment		80,745	C2740 - Manufacture of electric lighting equipment

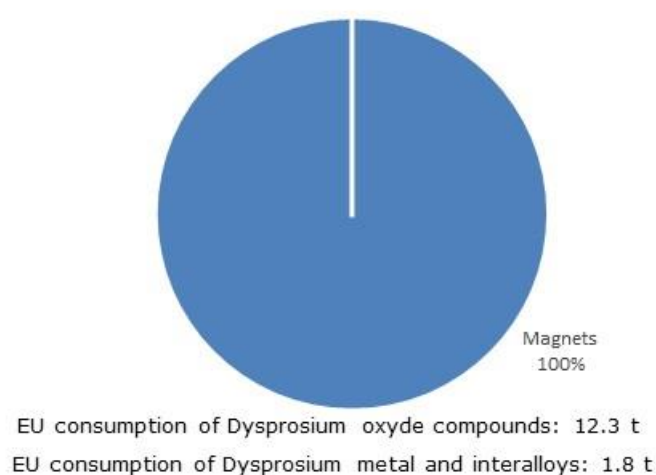
Cerium is used for a variety of applications, but the four main uses are polishing, metallurgy other than batteries, autocatalysts and glass (European Commission, 2017). Other uses for cerium include batteries, fluid cracking catalysts, other catalysts,

phosphors, ceramics, fertiliser, water treatment, paints and coatings (European Commission, 2017).

In recent years, demand for cerium used in the glass polishing sector has declined. It is likely to increase in the automotive catalyst sector due to low prices, good availability and stricter regulation on transportation emissions ARAFURA (2016).

### 21.3.3.2 Dysprosium applications

The main and almost exclusive use of dysprosium is in permanent magnets NdFeB (Figure 396). Dysprosium is added to NdFeB magnets (2-11% w/w) to increase the Curie temperature, which means that it allows the use of those magnets at up to 200°C. The main finished products driving dysprosium consumption for magnets include new generations of wind turbines, industrial motors, etc. Relevant industry sectors are described using the NACE sector codes in Table 154.



**Figure 396: EU end-uses of dysprosium. Average 2016-2018 (Eurostat, 2019; Guyonnet et al. 2015)**

**Table 154: Dysprosium applications, 2-digit NACE sectors, 4-digit NACE sectors and value added per sector (Eurostat, 2019c).**

Applications	2-digit NACE sectors	Value added of sector (millions €)	4-digit NACE sectors
Magnets	C25 - Manufacture of fabricated metal products, except machinery and equipment	148,351	C2599 - Manufacture of other fabricated metal products not elsewhere classified

### 21.3.3.3 Erbium applications

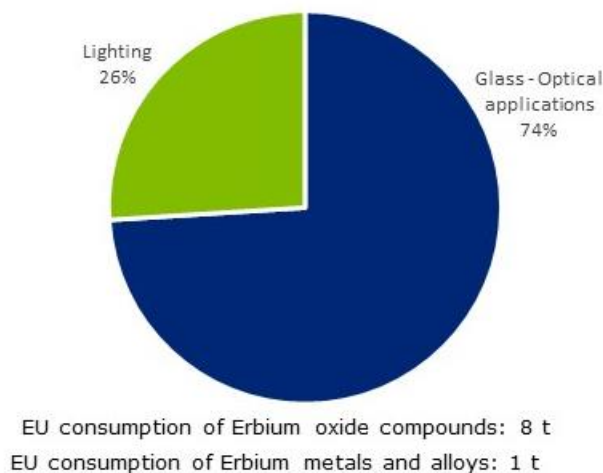
The majority of erbium is used in glass for optical application (74%), although phosphors for lighting applications are also an important use (EC, 2017), see Figure 397. Other uses for erbium include the nuclear industry (neutron-absorbing control rods), and metallurgy (metallurgical additive, erbium-nickel alloy) (BRGM, 2015).

The principal optical uses involve its pink-colored  $Er^{3+}$  ions, which have optical fluorescent properties particularly useful in certain laser applications (BRGM, 2015):

- Colorant for glass: erbium oxide has a pink color, and is sometimes used as a colorant for glass, cubic zirconia and porcelain.
- Erbium-doped optical silica-glass fibers are the active element in erbium-doped fiber amplifiers (EDFAs), which are widely used in optical communications.
- Co-doping of optical fiber with Er and Yb is used in high-power Er/Yb fiber lasers or
- Medical applications (i.e. dermatology, dentistry) with erbium-doped lasers Er:YAG

Information about the breakdown of the European market by application was not available at the time of writing.

Relevant industry sectors are described using the NACE sector codes in Table 155.



**Figure 397: EU end-uses of erbium. Average 2016-2018 (Eurostat, 2019; Guyonnet et al. 2015)**

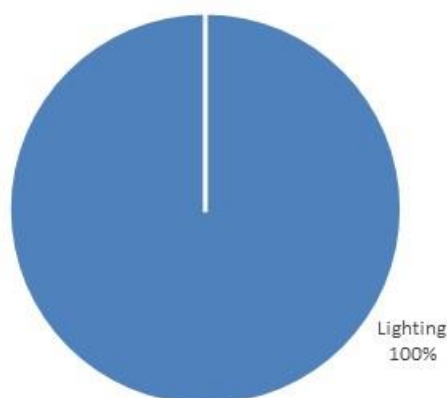
**Table 155: Erbium applications, 2-digit NACE sectors, 4-digit NACE sectors and value added per sector (Eurostat, 2019c).**

Applications	2-digit NACE sector	Value added of sector (millions €)	4-digit NACE sectors
Optical applications	C23 - Manufacture of other non-metallic mineral products	57,255	C2310 - Manufacture and processing of other glass, including technical glassware
Lighting	C27 - Manufacture of electrical equipment	80,745	C2740 - Manufacture of electric lighting equipment

#### 21.3.3.4 Europium applications

Europium is used in the in the world and in EU almost exclusively in lighting applications (BRGM, 2015), see Figure 398. It represents 5% of the composition of phosphors used for lighting. Some other uses in nuclear and optic industries can be mentioned, as well as protection for fraud of Euro banknotes (BRGM, 2015).

Relevant industry sectors are described using the NACE sector codes in Table 156.



EU consumption of Europium oxide compounds: 21 t  
 EU consumption of Europium metals and interalloys: 3 t

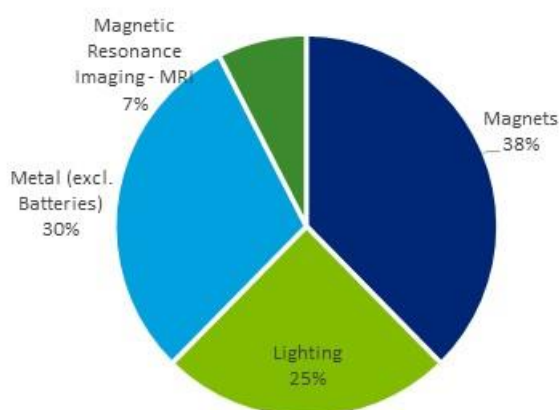
**Figure 398: EU end-uses of europium. Average 2016-2018 (Eurostat, 2019; Guyonnet et al. 2015)**

**Table 156: Europium applications, 2-digit NACE sectors, 4-digit NACE sectors and value added per sector (Eurostat, 2019c).**

Applications	2-digit NACE sector	Value added of sector (millions €)	4-digit NACE sectors
Lighting	C27 - Manufacture of electrical equipment	80,745	C2740 - Manufacture of electric lighting equipment

### 21.3.3.5 Gadolinium applications

Gadolinium is mainly used for NdFeB permanent magnets, for lighting applications and for metallurgy (see Figure 399), relevant industry sectors are described using the NACE sector codes in Table 157.



EU consumption of Gd oxide compounds: 10 t  
 EU consumption of Gd metals and interalloys: 1.3 t

**Figure 399: EU end-uses of gadolinium. Average 2016-2018 (Eurostat, 2019; Guyonnet et al. 2015)**



The major applications for gadolinium can be described in more detail as follows:

- Gd is primarily used in NdFeB alloys (Kiggins, 2015) but also in SmCo alloys (Humphries, 2013) for temperature compensation and resistance to corrosion (BRGM, 2015).
- Gadolinium oxide is used as a luminophore and gives the green color in television tubes (BRGM, 2015).
- Gadolinium metal possesses unusual metallurgic properties, to the extent that as little as 1% gadolinium can significantly improve the workability and resistance to high temperature oxidation of iron, chromium, and related alloys. Gadolinium is used in metallurgical applications for improving the mechanical characteristics of alloyed steel, for desulphurisation, or for binding trace elements in stainless steel.
- Gd is used as a medical contrasting agent for MRIs (EC, 2017).
- Other uses of gadolinium include optics and nuclear industry. Indeed, gadolinium as a metal or salt has exceptionally high absorption of neutrons and therefore is used for shielding in neutron radiography and in nuclear reactors (EC, 2017).

Information about the breakdown of the European market by application was not available at the time of writing.

**Table 157: Gadolinium applications, 2-digit NACE sectors, 4-digit NACE sectors and value added per sector (Eurostat, 2019c).**

<b>Applications</b>	<b>2-digit NACE sector</b>	<b>Value added of sector (millions €)</b>	<b>4-digit NACE sectors</b>
Magnets	C25 - Manufacture of fabricated metal products, except machinery and equipment	148,351	C2599 - Manufacture of other fabricated metal products not elsewhere classified
Lighting	C27 - Manufacture of electrical equipment	80,745	C2740 - Manufacture of electric lighting equipment
Metal (excl. Batteries)	C24 - Manufacture of basic metals	55,426	C2410 - Manufacture of basic iron and steel and of ferro-alloys
MRI	C21 - Manufacture of basic pharmaceutical products and pharmaceutical preparations	80,180	C2100 - Manufacture of pharmaceutical preparations

### 21.3.3.6 Holmium, Lutetium, Ytterbium and Thulium applications

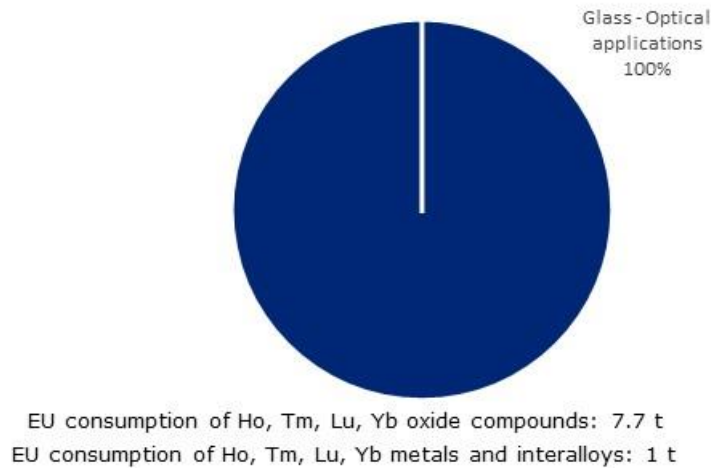
The use of holmium, thulium, ytterbium and lutetium in individual applications is too small to be estimated with accuracy. Their major uses are as follows:

- Holmium: pigments, magnets, lasers and nuclear.
- Thulium has no real commercial use; but glass, phosphors and fibre optics have potential.
- Ytterbium: fibre optics, lasers, photovoltaics, stress gauges.
- Lutetium: phosphors, PET detectors, glass.

Each one of these elements are used in niche applications mostly related to their optical properties (Laser dopants, fiber optics, radiography, etc.) – Figure 400.

Information about the breakdown of the European market by application was not available at the time of writing.

Relevant industry sectors are described using the NACE sector codes in Table 158.



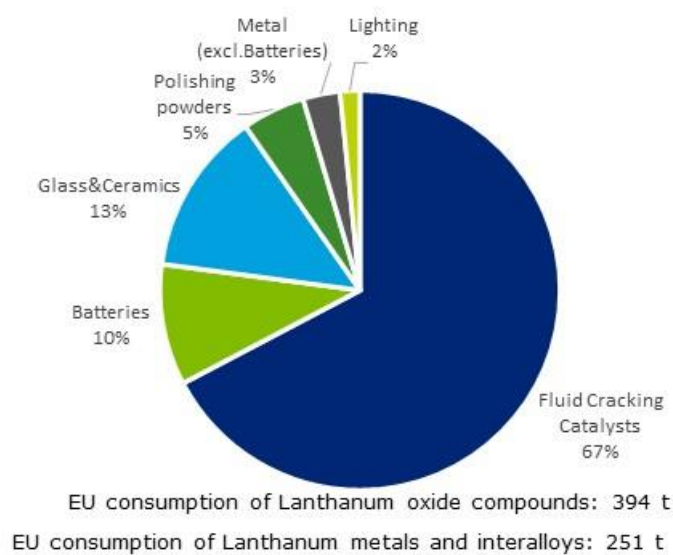
**Figure 400: EU end-uses of Ho, Tm, Lu, Yb. Average 2016-2018 (Eurostat, 2019; Guyonnet et al. 2015)**

**Table 158: Ho, Lu, Tm, Yb applications, 2-digit NACE sectors, 4-digit NACE sectors and value added per sector (Eurostat, 2019c).**

Applications	2-digit NACE sector	Value added of sector (millions €)	4-digit NACE sectors
Glass - Optical applications	C23 - Manufacture of other non-metallic mineral products	57,255	C2310 - Manufacture and processing of other glass, including technical glassware

**21.3.3.7 Lanthanum applications**

Lanthanum is used for a variety of applications; its three main uses are in FCCs, nickel-metal hydride batteries and glass & ceramics. Other uses for lanthanum include autocatalysts, polishing powders, lighting applications, metallurgical uses, fertiliser, algal control and cement (EC, 2017). Relevant industry sectors are described using the NACE sector codes in and Table 159.



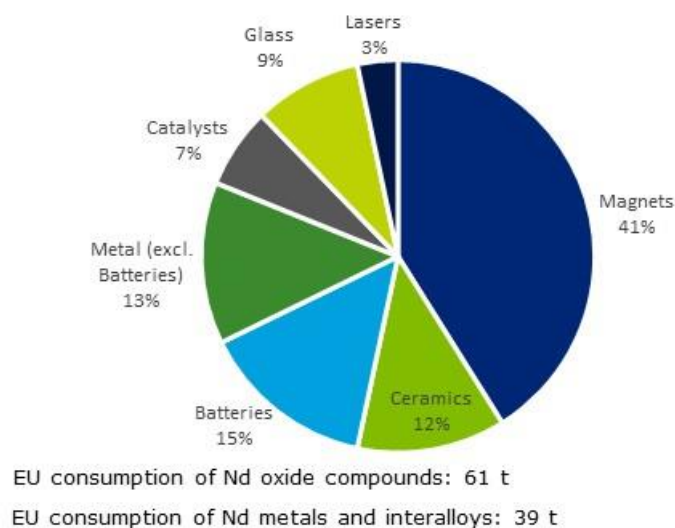
**Figure 401: EU end-uses of La. Average 2016-2018 (Eurostat, 2019; Guyonnet et al. 2015)**

**Table 159: La applications, 2-digit NACE sectors, 4-digit NACE sectors and value added per sector (Eurostat, 2019c).**

Applications	2-digit NACE sector	Value added of sector (M€)	4-digit NACE sectors
Fluid Cracking Catalysts	C19 - Manufacture of coke and refined petroleum products	17,289	C2029 - Manufacture of other chemical products not elsewhere classified
Batteries	C27 - Manufacture of electrical equipment	80,745	C2720 - Manufacture of batteries and accumulators
Glass& Ceramics	C23 - Manufacture of other non-metallic mineral products	57,255	C2331 - Manufacture of ceramic tiles and flags
Polishing powders	C26 - Manufacture of computer, electronic and optical products	65,703	C2670 - Manufacture of optical instruments and photographic equipment
Metal (excl. Batteries)	C24 - Manufacture of basic metals	55,426	C2410 - Manufacture of basic iron and steel and of ferro-alloys
Lighting	C27 - Manufacture of electrical equipment	80,745	C2740 - Manufacture of electric lighting equipment

### 21.3.3.8 Neodymium applications

The main application of neodymium in the EU is for NdFeB permanent magnets (37% of total use). The main finished products driving neodymium consumption for magnets include industrial motors, hard drives, automobiles and wind turbines.



**Figure 402: EU end-uses of Neodymium. Average 2016-2018 (Eurostat, 2019; Guyonnet et al. 2015)**

Neodymium is also used in NiMH batteries (Umicore, 2016), as a part of the batteries' cathode (13% of total use) although this use is declining (Higgins, 2016). In ceramics applications (11% of total use), neodymium is mainly used as a blue pigment in ceramic tiles (Yoldjian, 1985). In electronic ceramics, it is used as an insulator. Other applications include the manufacture of metals, catalysts, glass and lasers (BRGM, 2015).

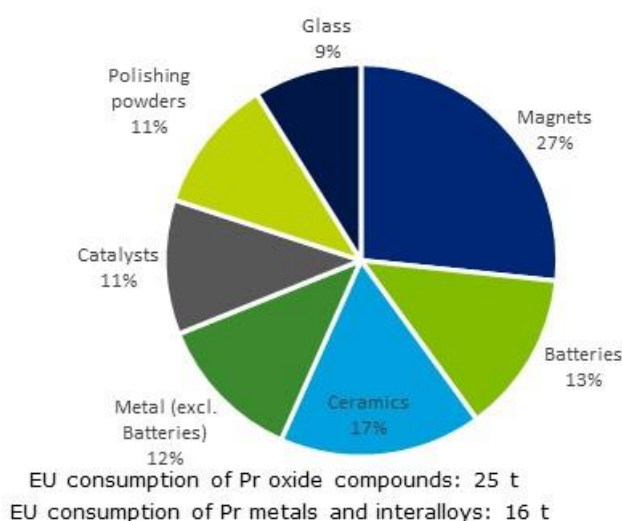
Relevant industry sectors are described using the NACE sector codes in Table 160.

**Table 160: Neodymium applications, 2-digit NACE sectors, 4-digit NACE sectors and value added per sector (Eurostat, 2019c).**

Applications	2-digit NACE sector	Value added of sector (M€)	4-digit NACE sectors
Magnets	C25 - Manufacture of fabricated metal products, except machinery and equipment	148,351	C2599 - Manufacture of other fabricated metal products not elsewhere classified
Ceramics	C23 - Manufacture of other non-metallic mineral products	57,255	C2331 - Manufacture of ceramic tiles and flags
Batteries	C27 - Manufacture of electrical equipment	80,745	C2720 - Manufacture of batteries and accumulators
Metal (excl. batteries)	C24 - Manufacture of basic metals	55,426	C2410 - Manufacture of basic iron and steel and of ferro-alloys
Catalysts	C20 - Manufacture of chemicals and chemical products	105,514	C2029 - Manufacture of other chemical products not elsewhere classified
Glass	C23 - Manufacture of other non-metallic mineral products	57,255	C2310 - Manufacture of glass and glass products
Lasers	C26 - Manufacture of computer, electronic and optical products	65,703	C2670 - Manufacture of optical instruments and photographic equipment

### 21.3.3.9 Praseodymium applications

Praseodymium is used in the EU in many applications. Most praseodymium is used in magnet applications in NdFeB magnets (27%), although ceramics, batteries and metallurgical uses other than batteries are also important applications. Other uses for praseodymium include catalysts, polishing and fiber amplifiers. In ceramics applications, praseodymium is mainly used as a yellow pigment in ceramic tiles (Yoldjian, 1985).



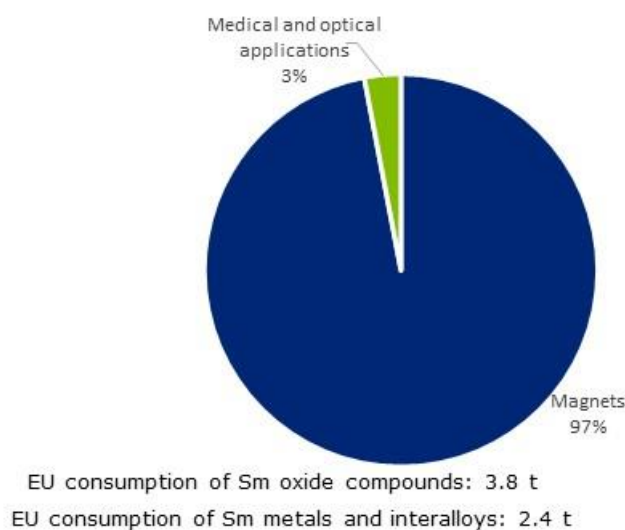
**Figure 403: EU end-uses of Praseodymium. Average 2016-2018 (Eurostat, 2019; Guyonnet et al. 2015)**

**Table 161: Praseodymium applications, 2-digit NACE sectors, 4-digit NACE sectors and value added per sector (Eurostat, 2019c).**

Applications	2-digit NACE sector	Value added of sector (M €)	4-digit NACE sectors
Magnets	C25 - Manufacture of fabricated metal products, except machinery and equipment	148,351	C2599 - Manufacture of other fabricated metal products not elsewhere classified
Ceramics	C23 - Manufacture of other non-metallic mineral products	57,255	C2331 - Manufacture of ceramic tiles and flags
Batteries	C27 - Manufacture of electrical equipment	80,745	C2720 - Manufacture of batteries and accumulators
Metal (excl. batteries)	C24 - Manufacture of basic metals	55,426	C2410 - Manufacture of basic iron and steel and of ferro-alloys
Catalysts	C20 - Manufacture of chemicals and chemical products	105,514	C2029 - Manufacture of other chemical products not elsewhere classified
Glass	C23 - Manufacture of other non-metallic mineral products	57,255	C2310 - Manufacture of glass and glass products
Polishing powders	C26 - Manufacture of computer, electronic and optical products	65,703	C2670 - Manufacture of optical instruments and photographic equipment

### 21.3.3.10 Samarium applications

The main application for samarium is SmCo permanent magnets. SmCo magnets have high permanent magnetization, which is about 10,000 times that of iron and is second only to that of neodymium magnets. However, samarium-based magnets have higher resistance to demagnetization, as they are stable to temperatures above 700 °C (cf. 300–400 °C for neodymium magnets) (BRGM, 2015). These magnets are found in small motors, headphones, and high-end magnetic pickups for guitars and related musical instruments.



**Figure 404: EU end-uses of Samarium. Average 2016-2018 (Eurostat, 2019; Guyonnet et al. 2015)**

Other uses of Sm are niche applications mostly related to its optical properties (laser dopant, radiography, etc.) and nuclear industry (EC, 2017).

Relevant industry sectors are described using the NACE sector codes in Table 162.

**Table 162: Samarium applications, 2-digit NACE sectors, 4-digit NACE sectors and value added per sector (Eurostat, 2019).**

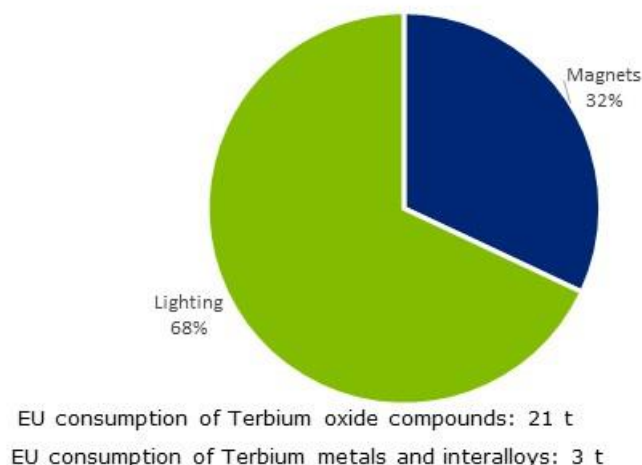
Applications	2-digit NACE sector	Value added of sector (M€)	4-digit NACE sectors
Magnets	C25 - Manufacture of fabricated metal products, except machinery and equipment	148,351	C2599 - Manufacture of other fabricated metal products not elsewhere classified
Medical and optical applications	C26 - Manufacture of computer, electronic and optical products	65,703	C2670 - Manufacture of optical instruments and photographic equipment

### 21.3.3.11 Terbium applications

Terbium is used in the EU for NdFeB permanent magnets (BRGM, 2015; CRS, 2013) and for lighting applications (BRGM, 2015):

- Like dysprosium, terbium is used in NdFeB magnets to increase the Curie temperature and thus enable the use of those magnets at elevated temperatures. However, Dy is favoured over Tb because it is cheaper (BRGM, 2015).
- Terbium oxide gives the yellow or green color in neons and fluo-compact lamps. It represents 4% of the composition of luminophores used for lighting (BRGM, 2015).

Relevant industry sectors are described using the NACE sector codes in Table 163.



**Figure 405: EU end-uses of Terbium. Average 2016-2018 (Eurostat, 2019a; Guyonnet et al. 2015)**

**Table 163: Terbium applications, 2-digit NACE sectors, 4-digit NACE sectors and value added per sector (Eurostat, 2019c).**

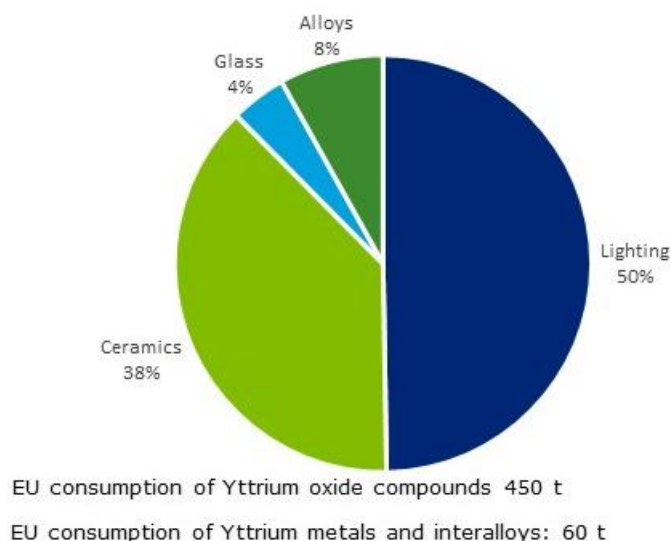
Applications	2-digit NACE sector	Value added of sector (millions €)	4-digit NACE sectors
Magnets	C25 - Manufacture of fabricated metal products, except machinery and equipment	148,351	C2599 - Manufacture of other fabricated metal products not elsewhere classified
Lighting	C27 - Manufacture of electrical equipment	80,745	C2740 - Manufacture of electric lighting equipment

### 21.3.3.12 Yttrium applications

Yttrium is used in the EU for lighting and ceramics applications mainly; other uses include the manufacture of glass and alloys:

- Y is the most used REE for the production of luminophores (70%-80%). Y-compounds are doped with other REE (Eu and Ce mainly) to produce luminophores. Y is used in both fluorescent and LED lamps.
- The major use of Y in ceramics is yttria in Yttria-Stabilised-Zirconia (YSZ) for refractory uses. Y is also used in electronics for the manufacture of oxygen sensors in vehicles.
- Yttrium oxide is added to the glass used to make camera lenses heat and shock resistant.
- Yttrium is also used as an additive in alloys. It increases the strength of aluminum and magnesium alloys.

Relevant industry sectors are described using the NACE sector codes in Figure 406.



**Figure 406: EU end-uses of Yttrium. Average 2016-2018 (Eurostat, 2019a; Guyonnet et al. 2015)**

**Table 164: Yttrium applications, 2-digit NACE sectors, 4-digit NACE sectors and value added per sector (Eurostat, 2019c).**

Applications	2-digit NACE sector	Value added of sector (M€)	4-digit NACE sectors
Lighting	C27 - Manufacture of electrical equipment	80,745	C2740 - Manufacture of electric lighting equipment
Ceramics	C23 - Manufacture of other non-metallic mineral products	57,255	C2331 - Manufacture of ceramic tiles and flags
Alloys	C24 - Manufacture of basic metals	55,426	C2410 - Manufacture of basic iron and steel and of ferro-alloys
Glass	C23 - Manufacture of other non-metallic mineral products	57,255	C2310 - Manufacture of glass and glass products

### 21.3.4 Substitution

In most of their applications, REE are not substitutable without losses of performance. However, for economic reasons, many R&D strategies have focused on reducing the amount of REE used in their different applications. These particular aspects are summarised in Table 165. The chapter contains substantial input from Machacek and Kalvig (2017: EURARE) providing more details about individual applications.

**Table 165: Individual Substitution Indexes**

REE	LREE					HREE						
	Ce	La	Nd	Pr	Sm	Dy	Er	Eu	Gd	Ho, Tm, Lu, Yb	Tb	Y
[SI(SR)]	0.99	0.97	0.98	0.97	0.98	1.00	0.99	0.95	0.99	1.00	0.95	0.99
[SI(EI)]	0.95	0.89	0.93	0.93	0.98	0.95	0.96	0.79	0.92	1.00	0.79	0.98

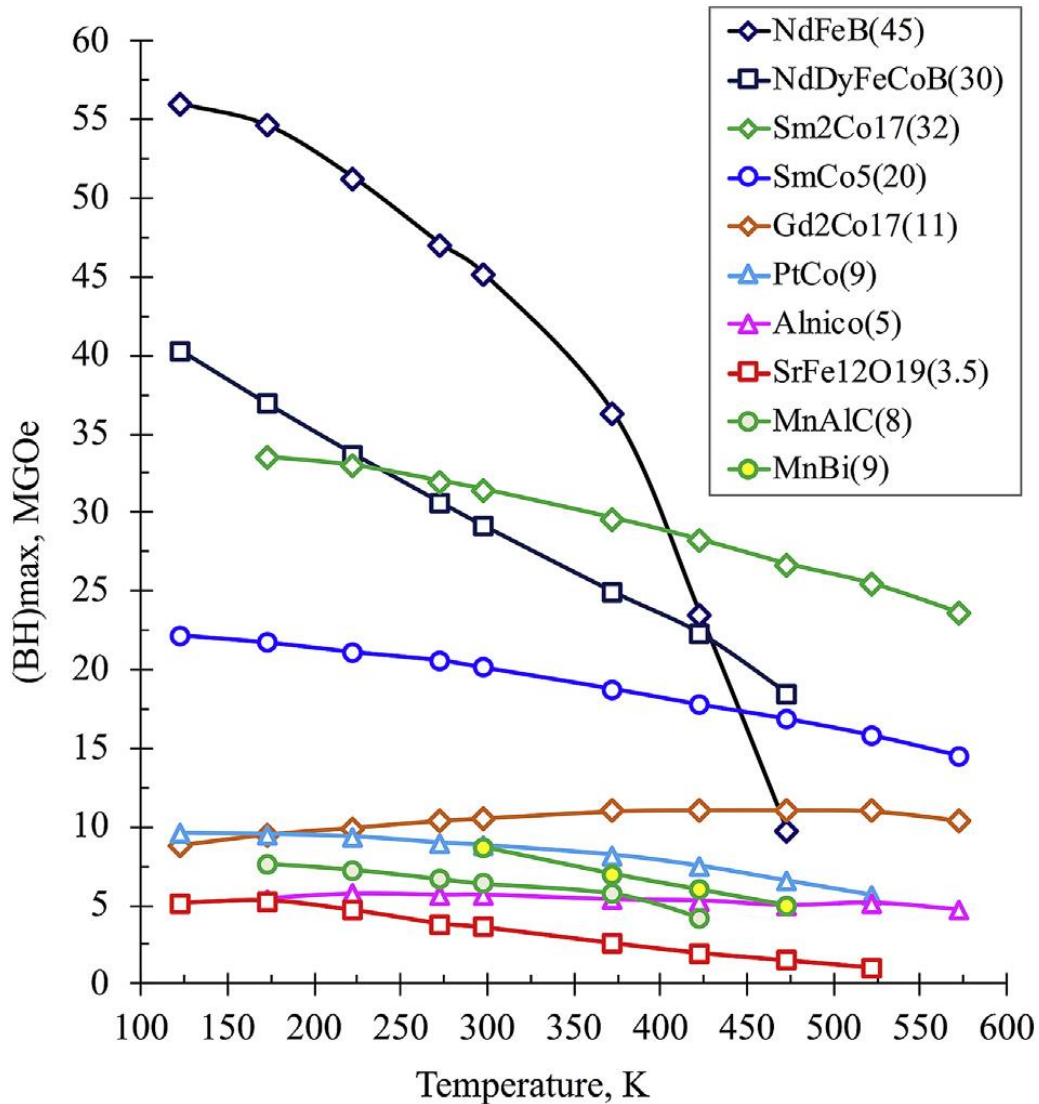


**Table 166: Summary of REE substitutes**

Use	Substitutes			
	General comment	REE	Substitution elements	Alternative technologies
Fluid cracking catalysts	Not easily substitutable	La	Ce	-
		Ce	La	
Autocatalysts	Some dematerialisation is possible	Ce	La, Nd, Pr	-
Other catalysts	Not easily substitutable	-	-	-
Glass	Not easily substitutable	Er, Lu, Ce	-	-
		...		
Batteries	There is a growing shift to Li-ion batteries in the major markets for NiMH batteries	Ce	-	Li-ion batteries. NiCd or lead-acid batteries are also an alternative
		Pr	-	
		La	Co	
		Nd	Co	
Metallurgy	Some dematerialisation is possible	Ce	Ca, La, Nd, Gd	-
		Gd	Pr	
		Pr	Gd	-
		La	Ce, Nd, Gd, Ca	-
Polishing	Some dematerialisation is possible	Ce	La, Zr, Pr, FeO, Al <sub>2</sub> O <sub>3</sub>	-
		La	Ce, FeO, Al <sub>2</sub> O <sub>3</sub>	-
Phosphors (lighting and displays)	The falling cost of LEDs means that there is now a viable competitor for fluorescent lamps for low-energy lighting	Er	Y, Gd	LED, that contain 1000 times less phosphor than fluorescent lamps
		Gd	Eu, Y, Tb	
		Tb	Eu, Y	
Ceramics	Not easily substitutable in either construction or electronics	Ce, La	-	-
Magnets	Several options exist to reduce or replace the rare earth content of magnets, either by material substitution or by using alternative magnet technology	Dy	Tb, Gd	wind turbine exempt of Dy using a cooling system to reduce the temperature of the use
		Gd	Dy, Tb	-
		Nd	Pr, Ce, La	ferrite or SmCo magnets
		Pr	Nd	ferrite or SmCo magnets
		Sm	-	NdFeB, ferrite or AlNiCo magnets
		Tb	Dy, Ga	-
Others	Some of the minor markets have substitutes.			
	YAG-lasers (as dopants, but with a different wavelength)	Nd, Y	- not replacable for the same Wave length	

### 21.3.4.1 Permanent magnets

Permanent magnets are key components of electric motors and power generators (wind turbines). The widely used high performance REE magnets are NdFeB, where neodymium improves magnet's strength (maximum energy product  $(BH)_{max}$ ) and allows to make magnets smaller compared to other types. Dysprosium and finer grain size are improving thermal coercivity (stability) of NdFeB magnets at higher temperatures.



**Figure 407: Magnets strength  $(BH)_{max}$  of most commercial permanent magnets changing with temperature. The value in parentheses in  $(BH)_{max}$  at 298 K (25°C). (Cui et al. 2018)**

A long-term approach to reducing use of REE is to develop non-RE magnets that can fill in this gap between hard ferrite and REE magnets.

**Table 167: Comparison of motor magnet price and maximum energy product (BH)<sub>max</sub> in 2016 and 2022 (estimated). (Cui et al. 2018)**

	(BH) <sub>max</sub> , MGOe		Price, \$/kg	
	2016	2022	2016	2022
<b>NdFeBDy(NH42SH)</b>	40–42	42	\$60	\$120
<b>SmCo (SC-3215)</b>	31–32	34	\$128	\$210
<b>AlNiCo-9</b>	9	11	\$71	\$80
<b>Ferrite (Sr-8B)</b>	3.8	3.8	\$4	\$4

Substitution strategies for NdFeB permanent magnets in electric motors and power generators aim at reducing the use of Nd and Dy, using other REE, developing magnets without REE, or developing motors without REE permanent magnets.

### Improving resource efficiency

REE resource efficiency in permanent magnets reducing supply risk and costs, whilst maintaining or increasing their performance, has been a strong driver of industry R&D over the last decade.

Two main approaches are used to reduce the use of Nd and Dy in NdFeB magnets, by diffusion of Dy into the magnet material in place of direct alloying, and reducing the grain size in the magnets to nanoscale (Kozawa 2010). An example is Hitachi Metals (Gehm 2013) who have developed magnets which reduce Dy content in NdFeB magnets, without a reduction in their high temperature coercivity.

### Substitution by other REE

Up to 25% of Nd can be substituted by Pr without significantly affecting magnetic properties of materials (Binnemans, 2014b).

Substitution of Nd and Dy by other REE (Ce, Gd) in NdFeB magnets leads to reduction of the magnetic properties.

SmCo magnets could replace NdFeB magnets for selected applications, but SmCo magnets are twice as expensive, and have around 50-75% magnetic strength of NdFeB magnets.

### Substitution by REE-free magnets

In the last years, great progress has also been made toward improving the microstructure and physical properties of non-REE magnets. They are not as strong as NdFeB magnets, but some of them are much cheaper and contain abundant elements. The general goal for the development of non-REE magnets is to fill in the gap between the most cost-effective, but low performing hard ferrite magnet, and the most expensive, but high performing REE magnets. Several new candidate materials systems were investigated, including Mn based, high magnetocrystalline anisotropy alloys (MnBi and MnAl compounds), spinodally decomposing alloys (Alnico), high-coercivity tetrataenite L10 phase (FeNi and FeCo), and nitride systems (iron nitride Fe<sub>16</sub>N<sub>2</sub>) or carbide systems (Co<sub>2</sub>C/Co<sub>3</sub>C). However it is not clear how practical or close to market these materials are and it can be argued that commercialisation is likely to take several years, even once significant improvements have been achieved.

**Table 168: The REE substitution in the permanent magnet sector (Cui et al. 2018; Machacek and Kalvig 2017: EURARE)**

Existing solutions	Challenges and comparison with NdFeB magnets
Ferrite magnets could substitute NdFeB magnets for selected applications, such as in wind turbines.	Ferrite magnets are more than 10 times cheaper, but NdFeB magnets are 10 times stronger
AlNiCo magnets (developed first in 1931) could substitute NdFeB magnets for selected applications where high temperatures and mechanical properties are required.	AlNiCo-9 magnets are similarly expensive, but NdFeB magnets are 4 times stronger. However, magnets' remarkable temperature stability (even at 500°C) and good mechanical properties earned its small market share (5%). Cobalt, the most expensive component with high supply risk, is needed for magnetisation and coercivity.
MnAl alloys (stabilised with C, Ga, Cu, Fe, Ni, Co, Cr, Ti, Mo, B or Zn)	MnAl alloys have good resistance to corrosion and low density, raw materials are abundant; but NdFeB magnets are 5 times stronger, and the metallurgy and magnetism of the MnAl are very complex.
MnBi alloys	MnBi has low decomposition temperature of 535 K (262°C) which makes the bulk magnet production difficult. NdFeB magnets are 5 times stronger.
Tetrataenite L1 <sub>0</sub> FeNi found in a meteorite in 2010	L1 <sub>0</sub> -FeNi is one of the few non-REE materials that has the potential to reach the strength of REE permanent magnets. It is intensively studied, but it is very challenging to reproduce the lattice structure with alternating monatomic layers of Fe and Ni formed over billion years in meteorites. Main issues are purity of the feedstock powder and thermal stability of the desired phase during bulk magnet fabrication process. Best approaches achieved only 19% of the L1 <sub>0</sub> -FeNi phase.
Iron Nitride (Fe <sub>16</sub> N <sub>2</sub> ) alloy discovered in 1950's, once commercially available as permanent magnets, could substitute NdFeB magnets in temperatures up to 355K (82 °C).	Iron Nitride (Fe <sub>16</sub> N <sub>2</sub> ) magnets could theoretically be three times stronger than NdFeB magnets enabling size and weight reduction in motors without compromising power or torque. However, they are difficult to produce, they decompose quickly above 300°C, coercivity needs to be improved, they will need the same corrosion protection as raw iron. US Niron Magnetics (2020) company is developing by arc melting, melt spinning, and nitriding the world's first commercial, bulk Iron Nitride (Fe <sub>16</sub> N <sub>2</sub> ) permanent magnets, owning 17 granted and 35 pending patents. (Niron Magnetics, 2020).
HfCo <sub>7</sub> and Zr <sub>2</sub> Co <sub>11</sub> compounds known since 1970's can have potential uses in the form of thin films for microelectromechanical systems (MEMS), data storage, and spintronics applications.	HfCo <sub>7</sub> and Zr <sub>2</sub> Co <sub>11</sub> nanoparticle films reach 30-40% magnetic strength of NdFeB magnets, but stability and control of phase purity of these compounds have been always a challenge. Higher material cost of Co and Hf and high supply risk is an important issue for using Hf-Co, Zr-Co as bulk magnets.
Carbides	Co <sub>3</sub> C and Co <sub>2</sub> C

## Substitution by technology change

Next to materials substitution, other REE-free motor technologies could represent viable option to REE based motors. Producers are re-designing machines in order to make them compatible with ferrite magnets (servo motors in cars and motors in industrial applications; ERECON 2015).

There are many alternatives for permanent magnet synchronous generators (PMSG) in wind turbines that require less or no REE: doubly-fed induction generator (DFIG), electrically excited synchronous generator (EESG), squirrel-cage induction generators linked to a full converter, PMSG substitution with high-temperature superconductors (HTS; Pavel et al. 2016a).

Permanent magnets are widely used in electric vehicles in highly efficient PM synchronous-traction motor (PSM). There are some alternative electric motors: Tesla S uses an asynchronous motor (ASM), the Renault Zoe has an electrically excited synchronous motor (EESM). Another substitute for PSM are: ASM with high rpm, PMS with low-cost magnets, hybrid motor, the transversal flux motor (TFM) and the switched reluctance motor (SRM, still in research phase; Pavel et al. 2016a).

An EU project ReFreeDrive<sup>233</sup> also aims at developing new electric drives based on free of rare earth technologies, namely induction machines and synchronous reluctance machines. In order to develop and integrate the new powertrains for a final in-vehicle validation for two use cases (75kW, medium power range, and 200kW high power range). Another alternative technology for traction motors is switched reluctance motor.

**Table 169: Comparison of electric motor technologies which reduce or eliminate rare earth magnets. (Widmer et al. 2015)**

Motor technology	Reduced NdFeB magnet	Ferrite permanent magnet	Copper rotor induction	Wound rotor synchronous	Switched reluctance
Peak power	80 kW	80 kW	50 kW	50 kW	75 kW
Peak efficiency	98%	96%	96%	96%	97%
Active material cost	\$223	\$154	\$144	\$144	\$118
Active material cost per kW	\$2.78/kW	\$1.93/kW	\$2.88/kW	£2.88/kW	£1.57/kW
Torque density	15 Nm/kg	11 Nm/kg	10 Nm/kg	10 Nm/kg	15 Nm/kg

### 21.3.4.2 Batteries

“Lithium-ion (Li-ion) batteries are increasingly replacing NiMH batteries in computing, communication and consumer products (e.g. mobile phones and laptops), due to their easier manufacture in special shapes: indeed, electronics covers about 50% of the global market associated to lithium-ion batteries (Allied Market Research, 2016).

Although the manufacturing costs of Li-ion are still higher than the ones associated to NiMH batteries, Li-ion batteries are partially replacing NiMH batteries also in PHEVs and EVs, mainly because of their higher energy density and longer lifespan. Indeed, such types of electric vehicles can be charged by plugging them in a grid-provided electricity system

<sup>233</sup> <http://www.refreedrive.eu>

and thus require batteries with higher energy density in order to guarantee a range as wide as possible between charging stations. The battery for HEVs are charged through the gasoline combustion engine, and for this purpose the high- power density NiMH batteries are more suited, and therefor still represent the most used batteries in HEVs, although in 2013 lithium-ion batteries accounted for about 20% of all batteries used in HEVs (CEC, 2015).

However, NiMH batteries maintain a relevant role in large-size, stationary applications in which power-to-weight is less important (e.g. back-up units), as well as in high-temperature applications where Li-ion batteries are unsafe. China currently leads the production of small-size NiMH batteries, while the large-size ones are mainly manufactured in Japan.” (Machacek and Kalvig 2017: EURARE)

#### **21.3.4.3 Catalysts**

“La is crucial for FCC catalysts because it provides thermal stability and selectivity, and substitutes for La in FCC catalysts are known (Öko Institut, 2011). The only alternative can be considered the use of fluid cracking catalysts based on zeolites without REE, but this leads to products with poor, yet still acceptable, performance (Binnemans et al. 2013a).

In automotive catalysts REE (mostly cerium) are responsible for enhanced thermal stability and emission reduction. Currently no substitution materials are known for the REE used for automotive catalysts (Öko Institut, 2011).” (Machacek and Kalvig 2017: EURARE)

#### **21.3.4.4 Polishing**

“The price spike in 2011 boosted the industrial research both for improved technical solutions enabling the reduction of Ce use, as well as for alternative materials such as zirconia (especially for lower quality products). However, as price decreased again, these efforts to find substitutes were put on hold and the traditional use of CeO<sub>2</sub> were maintained.” (Machacek and Kalvig 2017: EURARE)

#### **21.3.4.5 Glass**

“Research activities focusing substitution and reduction of REE have been performed only for the past five years. In particular, Chinese industry is pursuing improvements in La-based optical glass, considering the foreseen future growth in demand for optical glass associated to the increasingly diffusion of smartphones, tablets and other electronic displays. The very specific role covered by REE-based additives used in glass manufacturing hinders the potential substitution of such compounds with other materials for most of the applications within this sector”. (Machacek and Kalvig 2017: EURARE)

#### **21.3.4.6 Phosphors**

“The research of alternative materials to substitute REE in phosphors applications have been mainly boosted by price spike in 2011. Despite some improvements in efficiency have been reached in lighting applications, thus enabling to partially reduce REE consumption, the identification of substitutes for REE is very hard, essentially due to the high purity required for phosphors.” (Machacek and Kalvig 2017: EURARE)

## 21.4 Supply

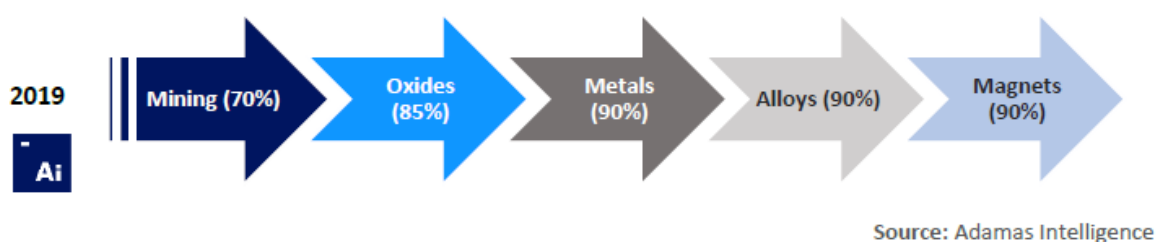
### 21.4.1 Global supply

The global mine production is estimated at 170,000t of rare-earth-oxide equivalent (REO<sup>234</sup>) in 2018 (Zion Markey Research 2019). According to China's Ministry of Commerce, production of REO in China was estimated to be at least 180,000 tonnes based on magnet material production.

Before the 1990s, less than 10% of total REE production were separated REE, in 2011 it was already 60% (Kingsnorth, 2012). Now, production of lanthanum and cerium oxides accounts for about 70%, praseodymium and neodymium oxides for around 20%, and other elements account for around 10%.

China provides around 80-90% of the world production of the whole range and purity of REE and their compounds, including the official production quota of 132,000 tonnes for 2019 and undocumented production.

In recent years, China's share of global rare earth mine production has fallen slightly as a handful of new rare earth mines have come on stream outside China. However, China's has continuously expanded share of downstream value-adding production of oxides, metals, alloys and magnets, where profit margins are greater and activities are environmentally cleaner. (Adamas Intelligence, 2019)

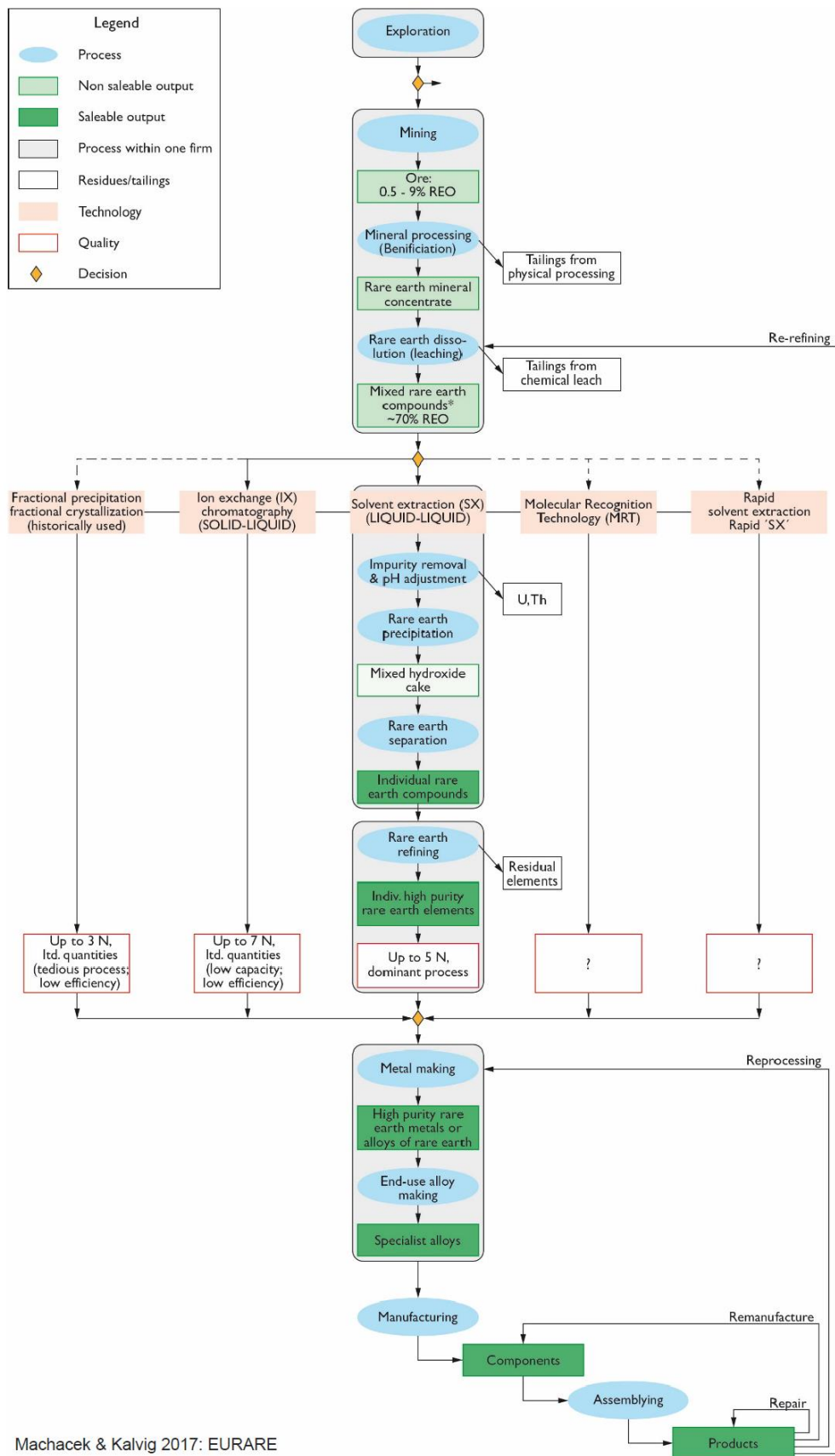


**Figure 408: Share of Chinese production in rare earths value chain (Adamas Intelligence, 2019)**

Until 2000, China exported mainly primarily mixed REE mineral concentrates, REE-containing components such as magnets, phosphors and polishing powders. Since the turn of the century, REE-exports by China increasingly included advanced REE-containing final consumer products such as batteries, mobile phones and LCDs. (Kingsnorth, 2012)

Lynas is the second largest global REE producer and the major producer outside China with an integrated production from mining to separated LREE and mixed HREE products (Neodymium and Praseodymium (NdPr) used in magnets, Lanthanum (La), Cerium (Ce) and Mixed Heavy Rare Earths (SEG)). Their assets include REE mines in Mt Weld, Western Australia and a concentration Plant- commissioned in 2011 and located 1.5km from the mine site; and separation and processing facility located in the Gebeng Industrial Estate near the Port of Kuantan in Malaysia producing since 2012. Other producers are small and offer limited range and quality of REE products.

<sup>234</sup> Average conversion factor of REE metal vs. Rare Earth Oxides (REO) is estimated at 0.85 (Guyonnet, et al. 2015).



Machacek & Kalvig 2017: EURARE

**Figure 409: Generic material supply chain for REE. Source: MiMa-GEUS, 2016 based on Gupta and Krishnamurty, 2005 (Machacek and Kalvig 2017: EURARE)**



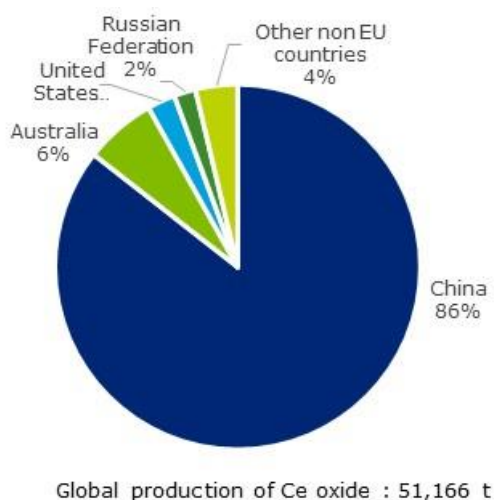
## 21.4.2EU supply chain

EU imports 100% of REE. In the EU, a few players are found at different stages of the REE value chain. Some have the ability to separate individual REOs (in Estonia and France) and manufacture REE-based products for various industries (phosphors, catalysts, polishing powders, etc.). There are also alloys makers and magnets manufacturers (in Germany, the UK, Slovenia) operating from imported processed materials. The ASTER project specifies 6,000 REE metals and compounds produced in EU (separation products), by Estonia and France (Guyonnet, 2015). There is no critical mass of REE transformation and manufacturing in the EU; although critical in many industries, a large proportion of REE consumption comes from finished products imports to the EU (magnets, alloys, hard drives, laptops, electric or hybrid vehicles, etc.).

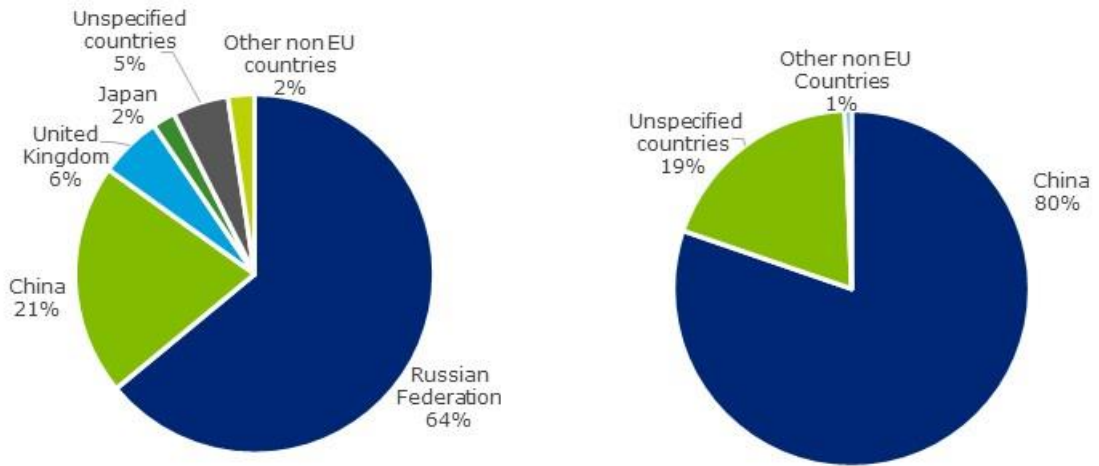
However, a few players are found at different stages of the REE value chain for the elements described hereunder.

### 21.4.2.1 Cerium

EU consumed in average around 3700 tonnes per year of cerium compounds (oxide content) and 305 tonnes of cerium metals and interalloys between 2016-2018 for wide range of applications (autocatalysts, glass and ceramics, polishing powders, fluid cracking catalyst, metals, batteries and lighting). According to statistics EU imported 5,241 tonnes of cerium compounds and 522 t of cerium metals and interalloys, while exports around 1500 tonnes and 217 tonnes respectively between 2016-2018.



**Figure 410: Global production of Cerium oxide, average 2012-2016 (WMD, 2019)**



EU imports of Cerium compounds: 5,241 t

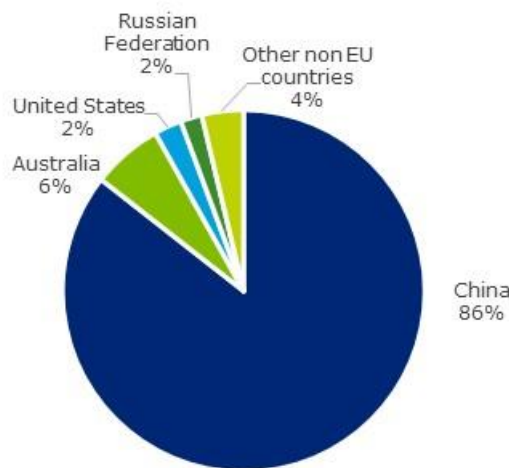
EU imports of Ce metals and interalloys: 522 t

**Figure 411: EU import of Cerium compounds (oxide content) and Cerium metals and interalloys (Eurostat, 2019a)**

Two companies have the ability to separate individual REOs (in Estonia and France) and manufacture REE-based products for various industries. In particular, the EU is likely to use more cerium for catalysts uses in the petroleum industry than in the rest of the world (BRGM, 2015).

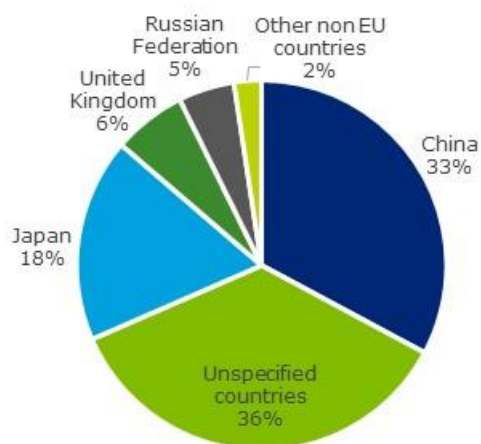
#### 21.4.2.2 Dysprosium

EU consumed in average around 12 tonnes per year of dysprosium compounds (oxide content) and 2 tonnes of dysprosium metals and interalloys between 2016-2018 and used in the magnets. According to statistics EU imported around 15 tonnes of dysprosium compounds and 2.5 tonnes of dysprosium metals and interalloys, while exports around 3 tonnes and 0.7 tonnes respectively between 2016-2018.

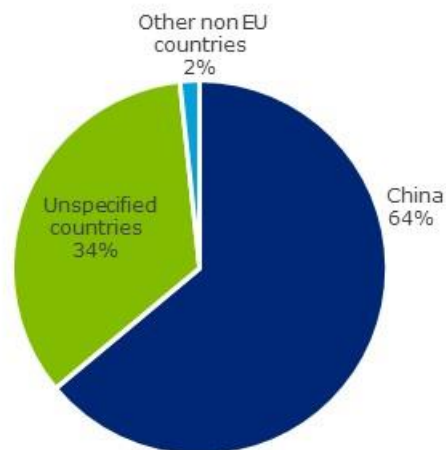


Global production of Dy oxide: 1,018 t

**Figure 412: Global production of Dysprosium oxide, average 2012-2016 (WMD, 2019)**



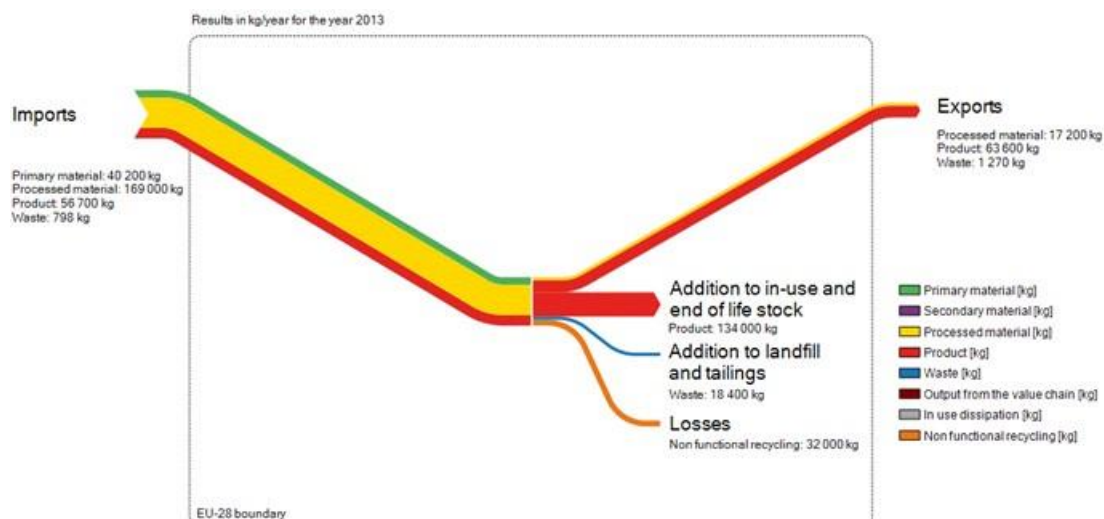
EU imports of Dy oxide compounds: 15 t



EU imports of Dy metals and interalloys: 2 t

**Figure 413: EU import of dysprosium compounds (oxide content) and dysprosium metals and interalloys (Eurostat, 2019a)**

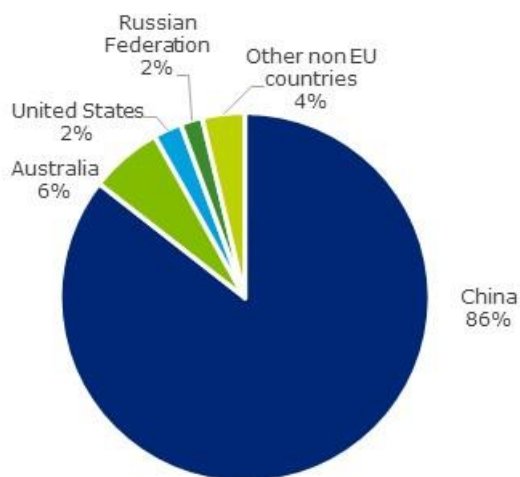
There are several alloys makers and magnets manufacturers (in Germany, the UK, and Slovenia) likely to use imported quantities of dysprosium alloys and compounds (BRGM, 2015).



**Figure 414: Simplified MSA. (Bio Intelligence Service, 2015)**

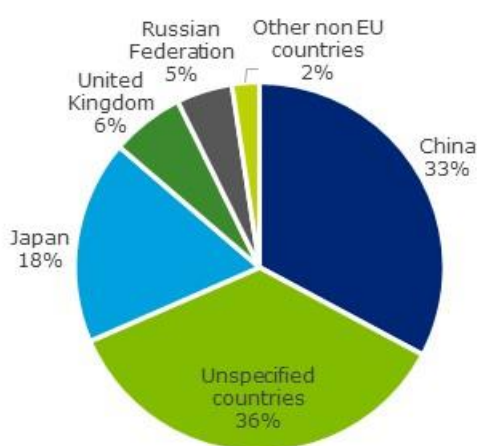
### 21.4.2.3 Erbium

EU consumed in average around 8 tonnes per year of erbium compounds (oxide content) and 1 tonne of erbium metals and interalloys between 2016-2018 for glass and optical applications and lighting. According to statistics EU imported around 11 tonnes of erbium compounds and 2 tonnes of erbium metals and interalloys, while exports around 3.7 tonnes and around 1 tonne respectively between 2016-2018.

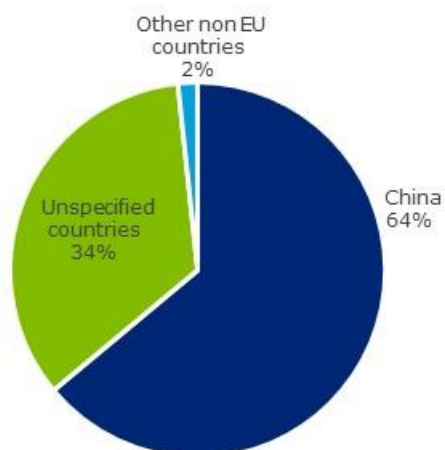


Global production of Er oxide: 483 t

**Figure 415: Global production of erbium oxide, average 2012-2016 (WMD, 2019)**

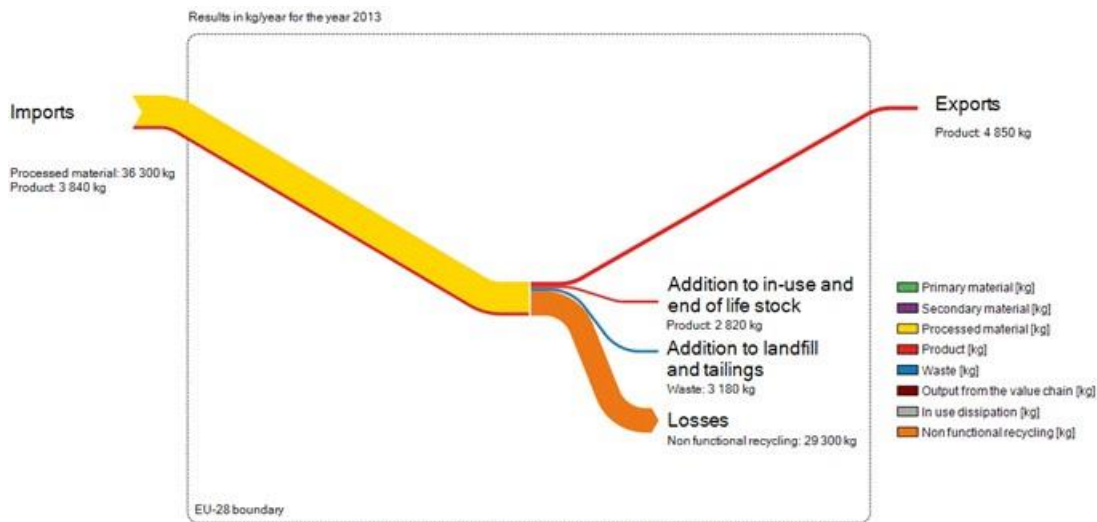


EU imports of Er oxide compounds: 11 t



EU imports of Er metals and interalloys: 2 t

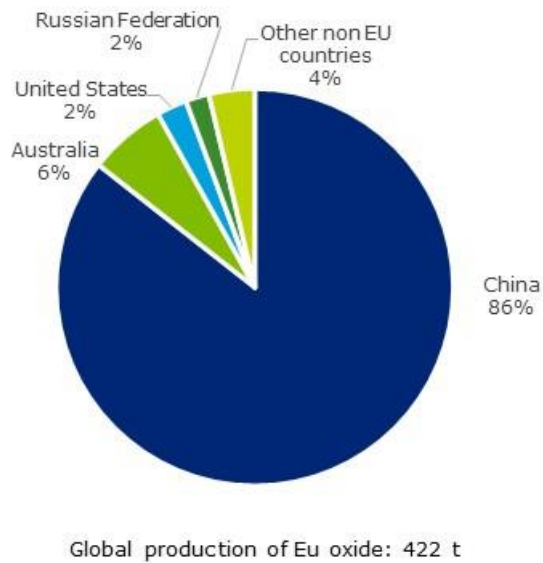
**Figure 416: : EU import of erbium compounds (oxide content) and erbium metals and interalloys (Eurostat, 2019a)**



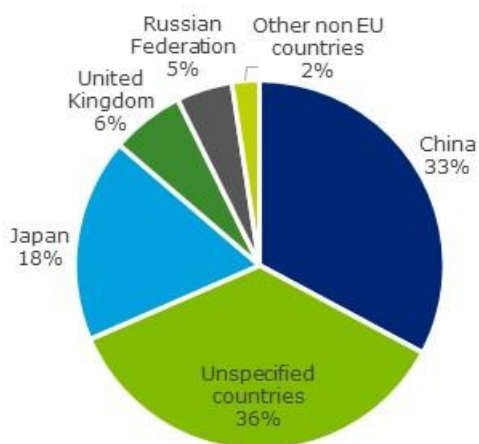
**Figure 417: Simplified MSA. (Bio Intelligence Service, 2015)**

#### 21.4.2.4 Europium

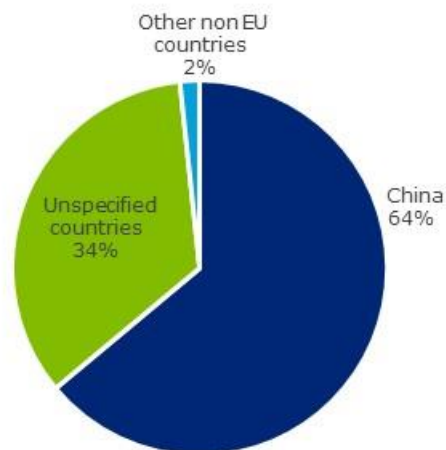
EU consumed in average around 21 tonnes per year of europium compounds (oxide content) and 3 tonnes of europium metals and interalloys between 2016-2018 for lighting applications. According to statistics EU imported around 30 tonnes of europium compounds and 5 tonnes of europium metals and interalloys, while exports around 10 tonnes and around 2.5 tonnes respectively between 2016-2018.



**Figure 418: Global production of europium oxide, average 2012-2016 (WMD, 2019)**



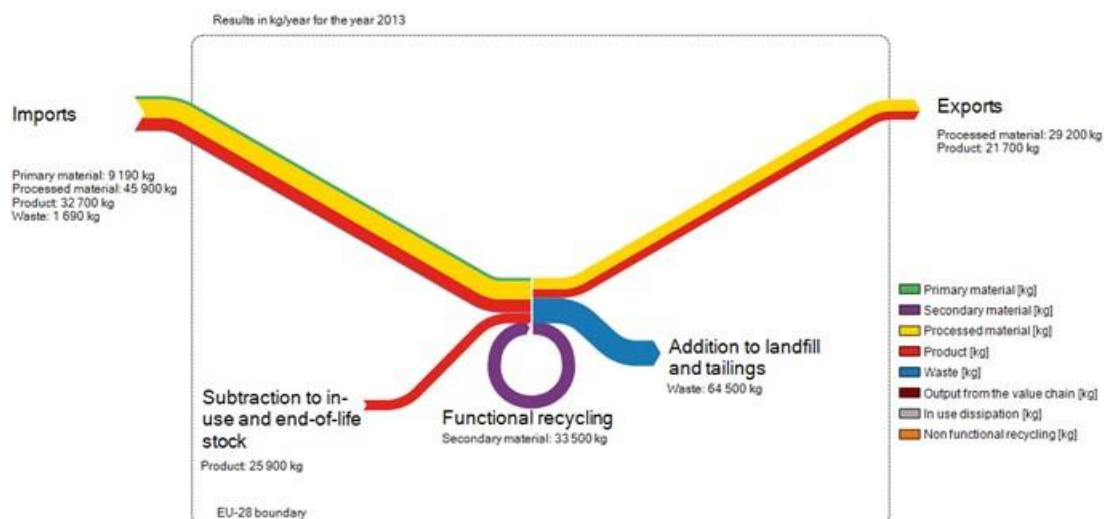
EU imports of Eu oxide compounds: 30 t



EU imports of Eu metals and interalloys: 5 t

**Figure 419: EU import of europium compounds (oxide content) and europium metals and interalloys (Eurostat, 2019a)**

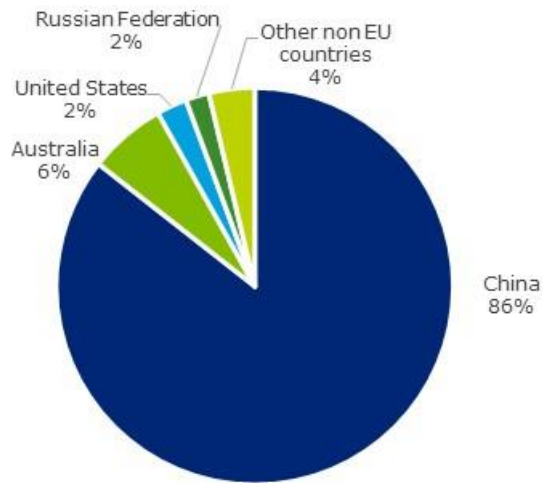
The separation of europium was performed in the Solvay plant in La Rochelle and was estimated at around 14 t/yr in the EU (Guyonnet et al., 2015) for the 2010-2014 period, but it discontinued after 2015.



**Figure 420: Simplified MSA. (Bio Intelligence Service, 2015)**

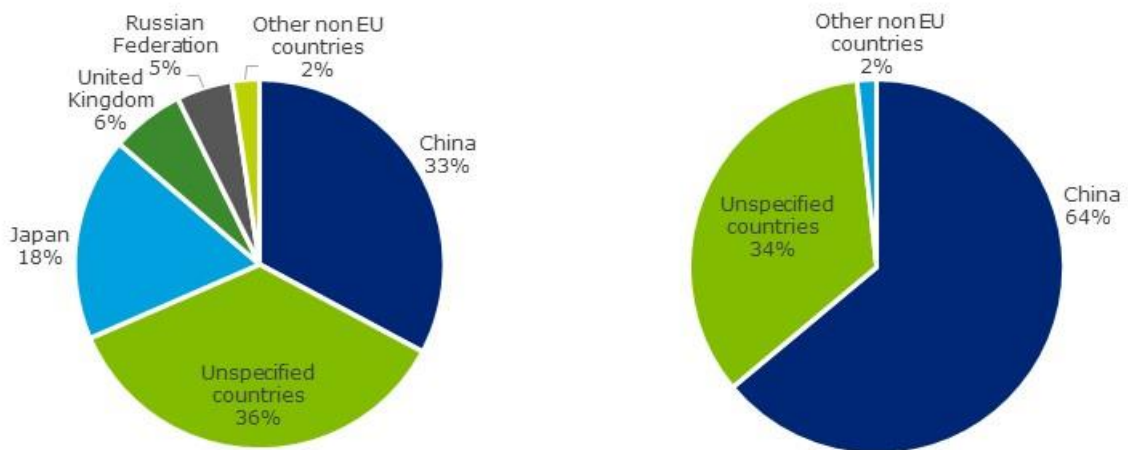
#### 21.4.2.5 Gadolinium

EU consumed in average around 10 tonnes per year of gadolinium compounds (oxide content) and 1.3 tonnes of gadolinium metals and interalloys between 2016-2018 for magnets, lighting, metals and magnetic resonance imaging applications. According to statistics EU imported around 15 tonnes of gadolinium compounds and 3 tonnes of gadolinium metals and interalloys, while exports around 4.9 tonnes and around 1.2 tonnes respectively between 2016-2018.



Global production of Gd oxide: 1,596 t

**Figure 421: Global production of gadolinium oxide, average 2012-2016 (WMD, 2019)**



EU imports of Gd oxide compounds: 15 t

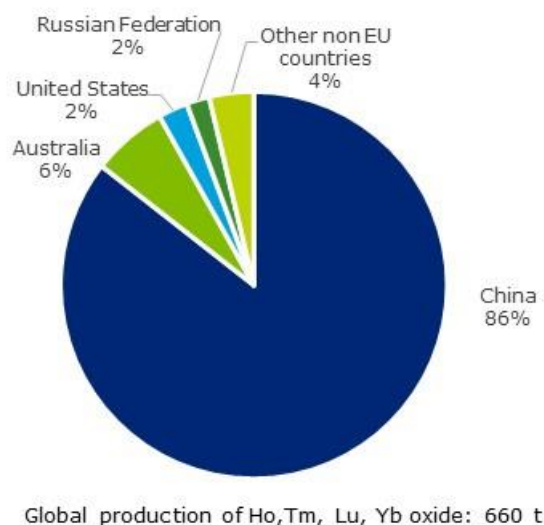
EU imports of Gd metals and interalloys: 3 t

**Figure 422: EU import of gadolinium compounds (oxide content) and gadolinium metals and interalloys (Eurostat, 2019a)**

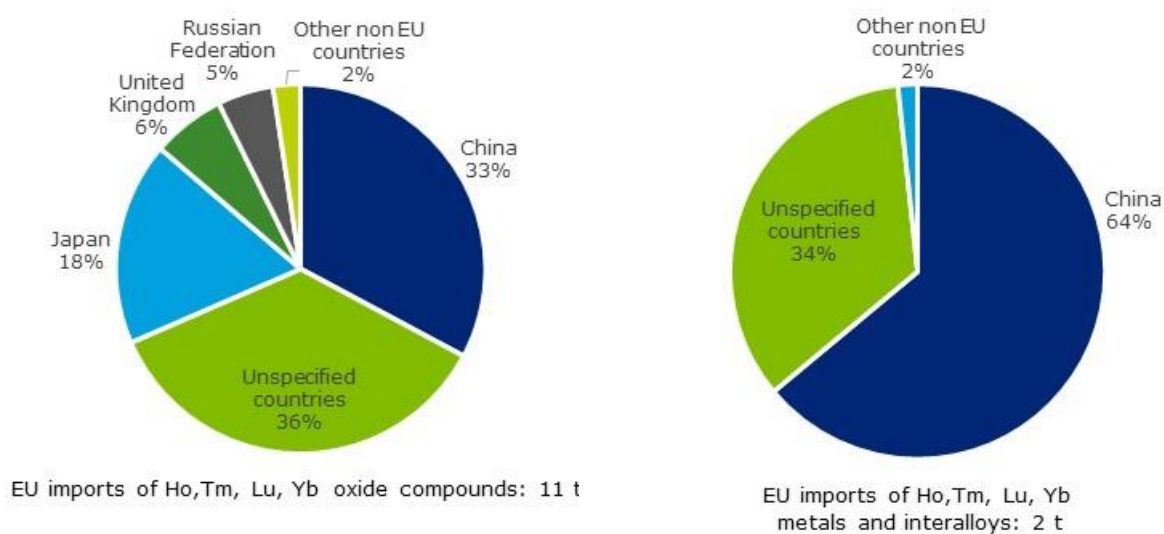
**21.4.2.6 Holmium, Lutetium, Ytterbium and Thulium**

EU consumed in average around 8 tonnes per year of holmium, lutetium, ytterbium and thulium compounds (oxide content) and 1 tonne of holmium, lutetium, ytterbium and thulium metals and interalloys between 2016-2018 for glass-optical applications. According to statistics EU imported around 11 tonnes of holmium, lutetium, ytterbium and thulium compounds and 2 tonnes of holmium, lutetium, ytterbium and thulium metals and

interalloys, while exports around 3.7 tonnes and around 1 tonne respectively between 2016-2018.



**Figure 423: Global production of Ho, Tm, Lu, Yb oxide, average 2012-2016 (WMD, 2019)**

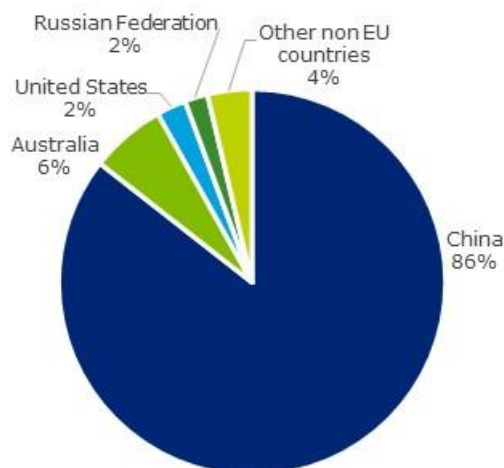


**Figure 424: EU import of Ho, Tm, Lu, Yb compounds (oxide content) and Ho, Tm, Lu, Yb metals and interalloys (Eurostat, 2019a)**

#### 21.4.2.7 Lanthanum

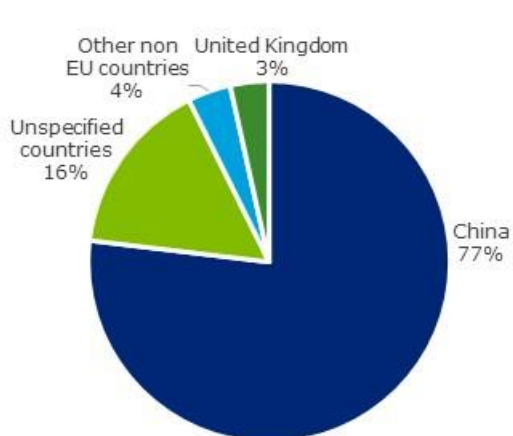
EU consumed in average around 394 tonnes per year of lanthanum compounds (oxide content) and 251 tonnes of lanthanum metals and interalloys between 2016-2018 for magnets, ceramics, batteries, metals, catalysts, glass, lasers applications. According to statistics EU imported around 2.8 kt of lanthanum compounds and 579 tonnes of lanthanum metals and interalloys, while exports around 2.4 kt and around 328 tonnes respectively between 2016-2018.



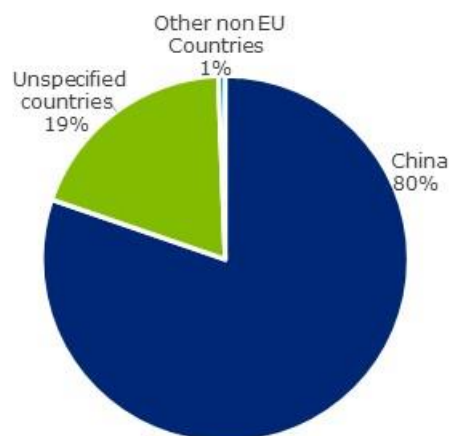


Global production of Lanthanum oxide: 29,328 t

**Figure 425: Global production of lanthanum oxide, average 2012-2016 (WMD, 2019)**



EU imports of of La oxide compounds: 2,829 t

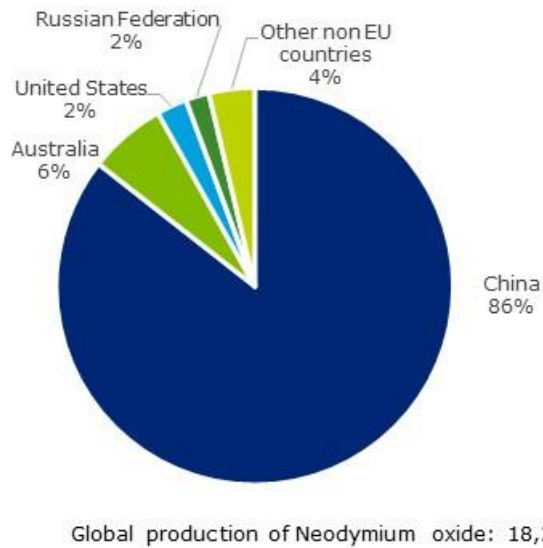


EU imports of La metals and interalloys: 579 t

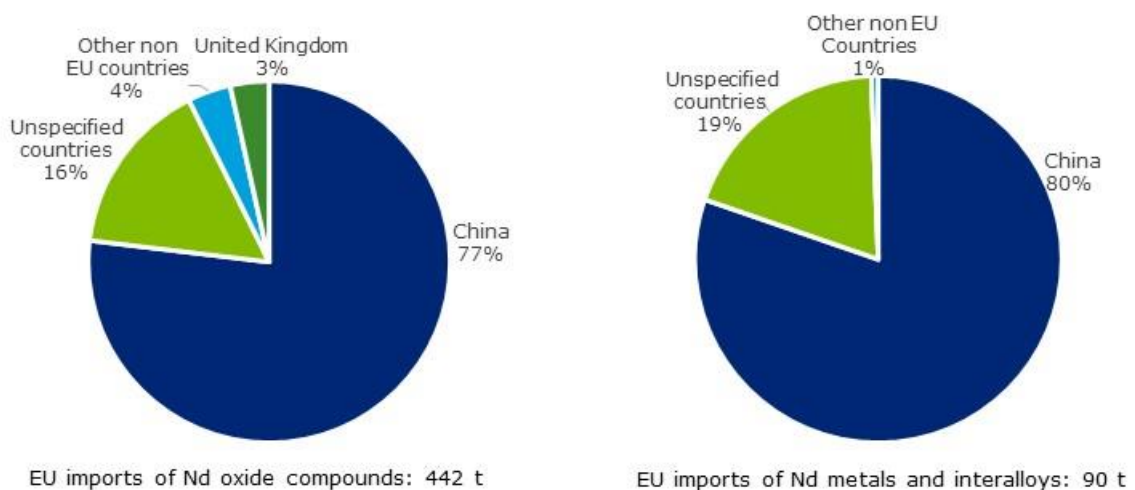
**Figure 426: EU import of lanthanum compounds (oxide content) and lanthanum metals and interalloys (Eurostat, 2019a)**

### 21.4.2.8 Neodymium

EU consumed in average around 91 tonnes per year of neodymium compounds (oxide content) and 39 tonnes of neodymium metals and interalloys between 2016-2018 for magnets, ceramics, batteries, metals, catalysts, glass, lasers applications. According to statistics EU imported around 442 tonnes of neodymium compounds and 90 tonnes of neodymium metals and interalloys, while exports around 380 tonnes and around 51 tonnes respectively between 2016-2018.



**Figure 427: Global production of neodymium oxide, average 2012-2016 (WMD, 2019)**

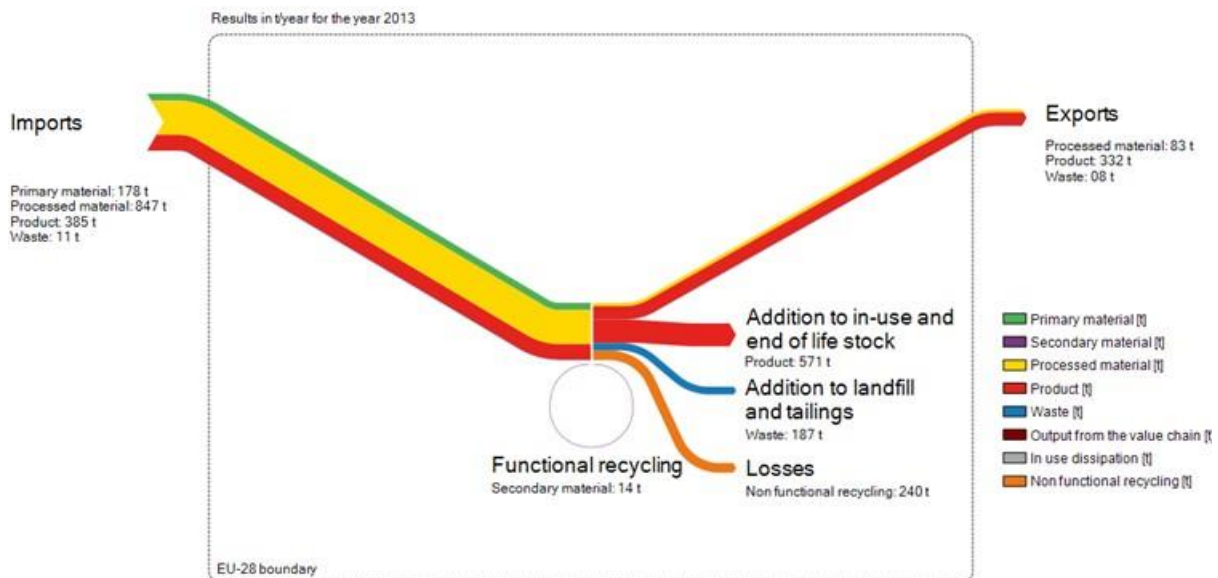


**Figure 428: EU import of neodymium compounds (oxide content) and neodymium metals and interalloys (Eurostat, 2019a)**

Some companies have the ability to separate individual REOs (in Estonia and France ) or to produce neodymium metal (in Estonia the company Silmet is separating rare-earth mixtures to produce neodymium metal (300-400 t/yr) (Guyonnet et al., 2015).

Downstream, there are also alloy makers and magnet manufacturers (in Germany, the UK, Slovenia) operating from imported processed materials.

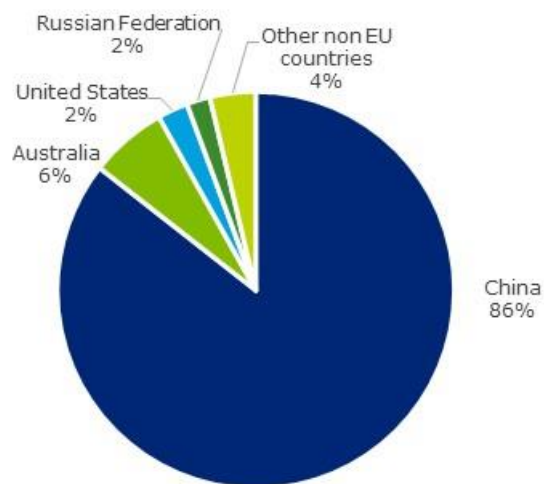
Other manufacturers of REE-based products are present in various industries (phosphors, catalysts, polishing powders, etc.) and are potential users of neodymium.



**Figure 429: Simplified MSA. (Bio Intelligence Service, 2015)**

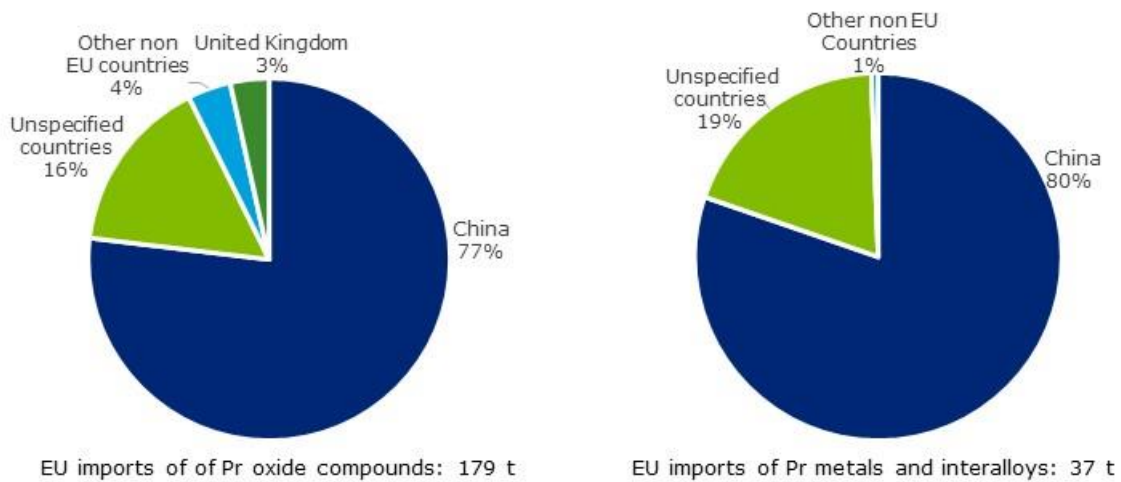
#### 21.4.2.9 Praseodymium

EU consumed in average around 25 tonnes per year of praseodymium compounds (oxide content) and 16 tonnes of praseodymium metals and interalloys between 2016-2018 for magnets, batteries, ceramics, metals, catalysts, polishing powders, glass applications. According to statistics EU imported around 179 tonnes of praseodymium compounds and 37 tonnes of praseodymium metals and interalloys, while exports around 154 tonnes and around 21 tonnes respectively between 2016-2018.



Global production of Praseodymium oxide: 5,413 t

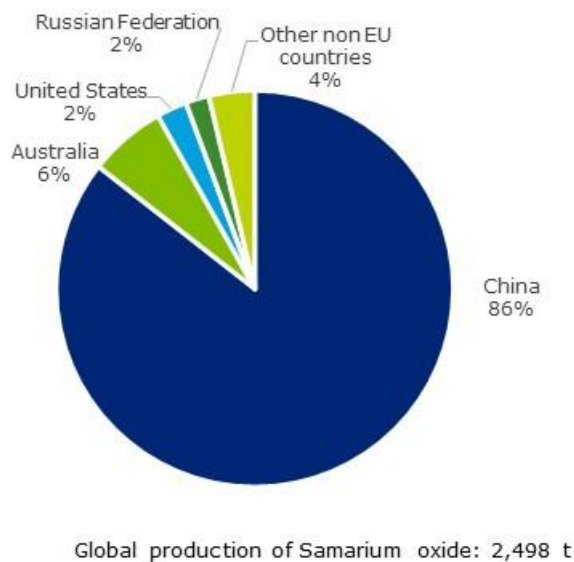
**Figure 430: Global production of praseodymium oxide, average 2012-2016 (WMD, 2019)**



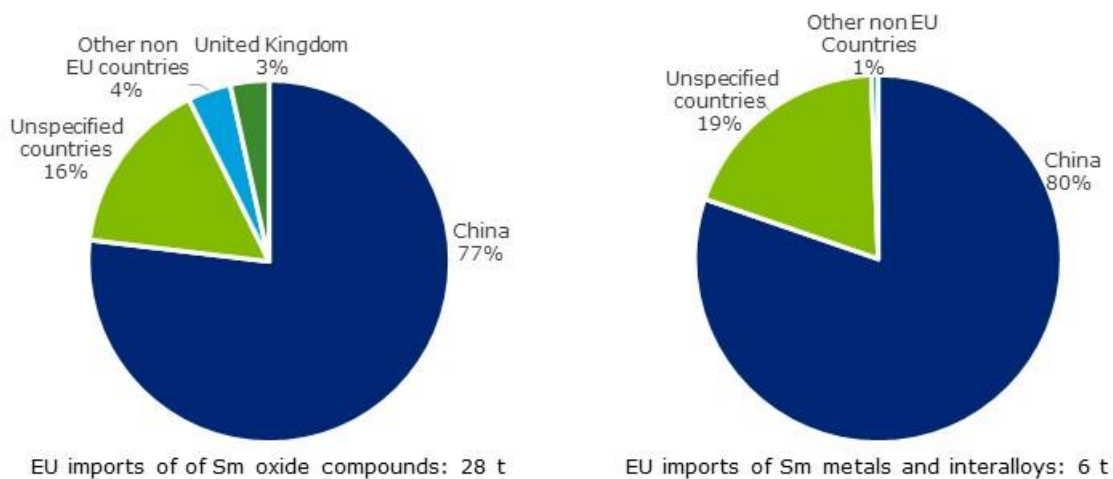
**Figure 431: EU import of praseodymium compounds (oxide content) and praseodymium metals and interalloys (Eurostat, 2019a)**

**21.4.2.10 Samarium**

EU consumed in average around 3.8 tonnes per year of samarium compounds (oxide content) and 2.4 tonnes of samarium metals and interalloys between 2016-2018 for magnets, ceramics, batteries, metals, catalysts, glass, lasers applications. According to statistics EU imported around 28 tonnes of samarium compounds and 6 tonnes of samarium metals and interalloys, while exports around 24 tonnes and around 3 tonnes respectively between 2016-2018.



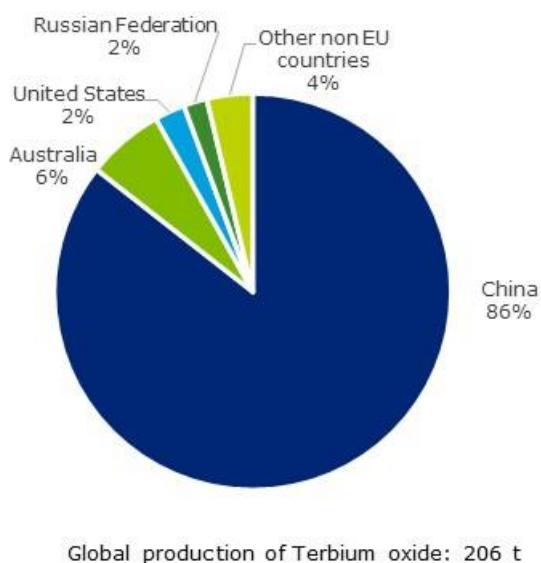
**Figure 432: Global production of samarium oxide, average 2012-2016 (WMD, 2019)**



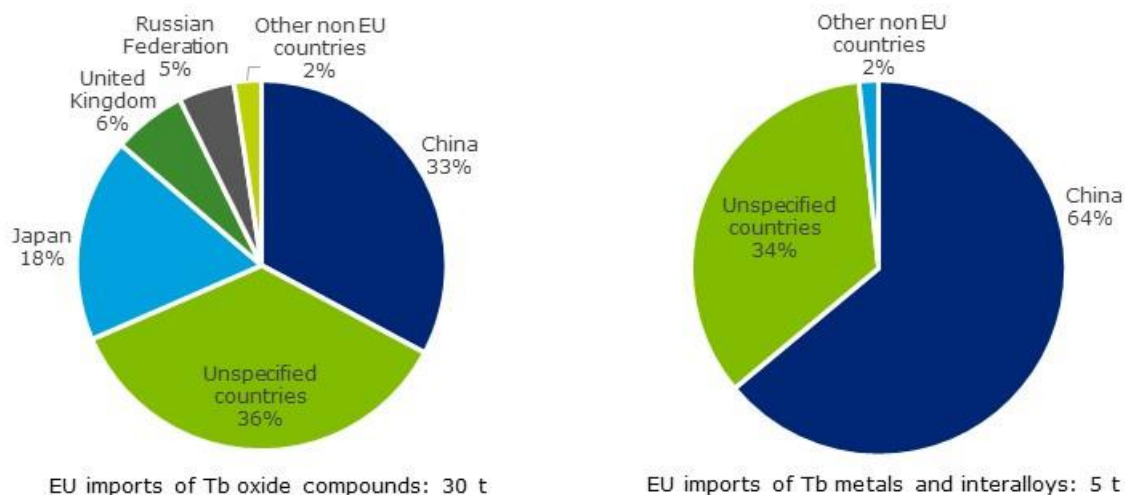
**Figure 433: EU import of samarium compounds (oxide content) and samarium metals and interalloys (Eurostat, 2019)**

#### 21.4.2.11 Terbium

EU consumed in average around 21 tonnes per year of terbium compounds (oxide content) and 3 tonnes of terbium metals and interalloys between 2016-2018 for magnets and lighting applications. According to statistics EU imported around 30 tonnes of terbium compounds and 5 tonnes of terbium metals and interalloys, while exports around 10 tonnes and around 2.5 tonnes respectively between 2016-2018.

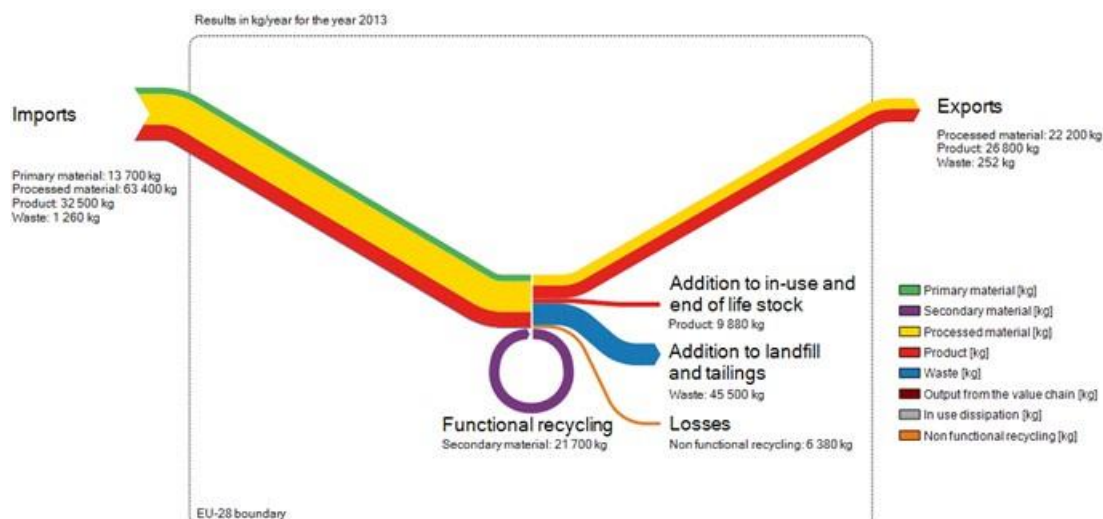


**Figure 434: Global production of terbium oxide, average 2012-2016 (WMD, 2019)**



**Figure 435: EU import of terbium compounds (oxide content) and terbium metals and interalloys (Eurostat, 2019a)**

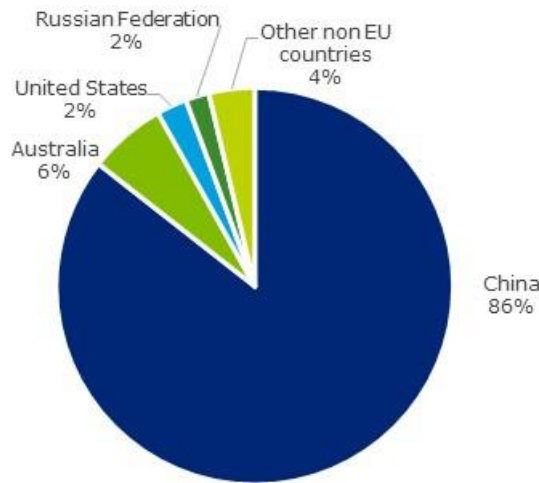
The separation of terbium metal was estimated at around 14 t/yr in the EU (Guyonnet et al., 2015) for the 2010-2014 period. Separation was performed in the Solvay plant in La Rochelle.



**Figure 436: Simplified MSA. (Bio Intelligence Service, 2015)**

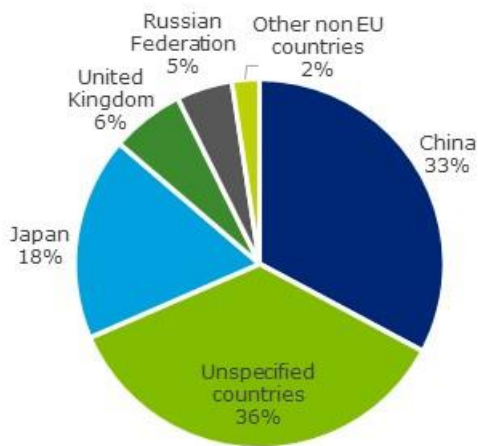
#### 21.4.2.12 Yttrium

EU consumed in average around 450 tonnes per year of yttrium compounds (oxide content) and 60 tonnes of yttrium metals and interalloys between 2016-2018 for magnets and lighting applications. According to statistics EU imported around 663 tonnes of yttrium compounds and 115 tonnes of yttrium metals and interalloys, while exports around 214 tonnes and around 56 tonnes respectively between 2016-2018.

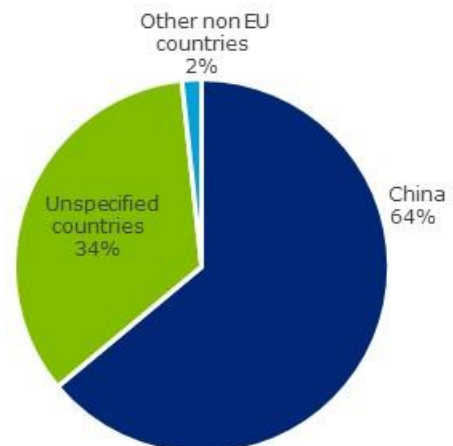


Global production of Yttrium oxide: 5,413 t

**Figure 437: Global production of yttrium oxide, average 2012-2016 (WMD, 2019)**



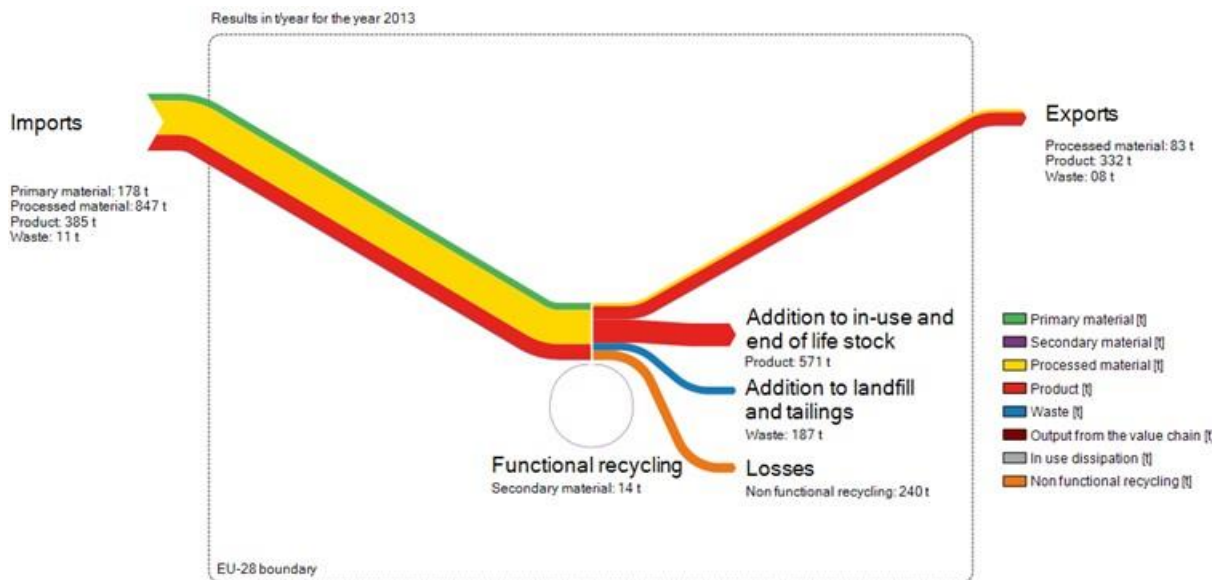
EU imports of Y oxide compounds: 663 t



EU imports of Y metals and interalloys: 115 t

**Figure 438: EU import of terbium compounds (oxide content) and terbium metals and interalloys (Eurostat, 2019a)**

The separation of yttrium metal was estimated at around 500 t/yr in the EU (Guyonnet et al., 2015) for the 2010-2014 period. Separation was mainly performed in the Solvay plant in La Rochelle.



**Figure 439: Simplified MSA. (Bio Intelligence Service, 2015)**

### 21.4.3 Supply from primary materials

The stages of production for hard rock deposits in the rare earth sector generally comprise mining, beneficiation, hydrometallurgical processing, separating, refining, alloying, and manufacturing rare earths into end-use items and components:

- mining of ores from the mineral deposits;
- beneficiation of the ore minerals into a mineral concentrate;
- hydrometallurgical processing to extract and concentrate the rare earths into a mixed chemical concentrate;
- separating and refining into individual REO. The oxides can be dried, stored and shipped for further processing into metals;
- converting the REO into metals with different purity levels;
- forming the metals into rare earth alloys;
- manufacturing the alloys into devices and components, such as permanent magnets.

#### 21.4.3.1 Geology, resources and reserves of REE

##### Geological occurrence and deposits:

Concentration of individual REE in the upper crust is summarized in Table 170.

**Table 170: Uppercrustal concentration of rare earth elements (Rudnick, 2003)**

	REE	Concentration (ppm)
LREE	Ce	63
	Nd	27
	La	31
	Pr	7.1



	Sm	4.7
	total LREE	132.8
HREE	Eu	1
	Tb	0.7
	Gd	4
	Er	2.3
	Dy	3.9
	Y	21
	Ho, Tm, Lu, Yb	very low
	total HREE	32.9
<b>Total</b>		<b>165.7</b>

REE ore deposits occur in a wide variety of rocks and genetic types (Wall, 2014; BRGM, 2015). In summary, the most important ones for commercial exploitation are carbonatite-associated deposits (including weathered carbonatites), ion adsorption deposits, alkaline igneous rocks (including alkaline granites), placer deposits, and more anecdotic hydrothermal deposits and seafloor deposits.

Deposits vary in terms of size and grade. Carbonatite-associated deposits tend to be medium to large tonnage and high grade. The main examples are the Bayan Obo mine in China (accounting for about 60% of LREE global production in 2014) and Mountain Pass in the USA, with bastnaesite as the main ore mineral. They are typically enriched in LREE.

Alkaline rock deposits are generally larger tonnage but lower grade. An example is the nepheline syenite deposit of Lovozero in Russia, where loparite is the main ore mineral.

Beach sand placer deposits are variable in size and generally low grade; the main REE-bearing mineral in those deposits is monazite (with potential thorium content) which is exploited as a by-product of rutile, ilmenite and others.

Ion adsorption deposits are rather small and low grade but relatively rich in HREE contained in ion-adsorption clays and xenotime mineralization. The majority is located in Southern China. They are mostly artisanal small-scale mines, however accounting for 98% of HREE global production.

The concentration of rare earth elements varies with each type of mineralisation, and also between each individual ore body.

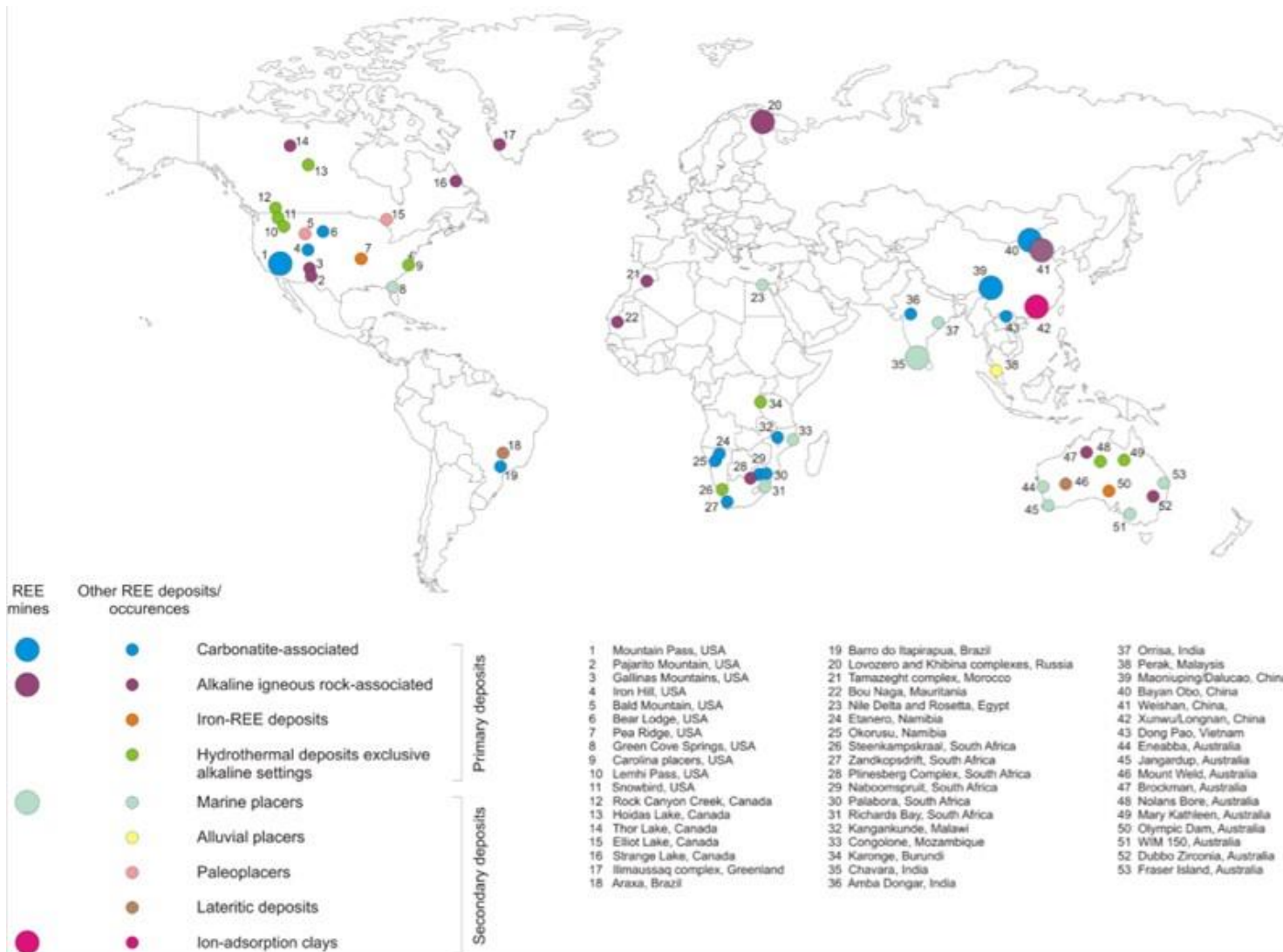


Figure 440: Global REE deposits (BGS 2019)

## Global resources and reserves<sup>235</sup>

There is no single source of comprehensive evaluations for resources and reserves that apply the same criteria to deposits of REE in different geographic areas of the EU or globally.

Most of the REO-equivalent reserves estimates range from 80 million tonnes (BRGM, 2015) to 120 million tonnes (USGS 2020), as presented in **Error! Reference source not found.** The USGS collects information about the quantity and quality of mineral resources, but does not directly measure reserves, and companies or governments do not directly report reserves to the USGS. Association of China Rare Earth Industry (ACREI 2019) refers to 246 million tonnes of global REO reserves, including 169 million tonnes in China in 2018. Weng et al. (2015) published a global REO resources figure of 619.5 Mt, split between 267 deposits and grading 0.63% TREO and hosting c. 554 Mt TREO, based on JORC, NI43-101, SAMREC and CRIRSCO mineral resource data gathered in 2013-2014.

Individual companies may publish regular mineral resource and reserve reports under various reporting systems, which makes their comparison and summing up difficult. Figures for countries where no reporting obligation apply are the most difficult to evaluate and can vary from one source to another (e.g. Brazil, China, India) which explain some differences.

Looking from a tonnage point of view alone it appears that the global REE-reserve is sufficient for about 500 of years of production. However, neither the tonnage nor the grade alone makes a mine, because the REE-distribution, as well as many other parameters, should be considered. World resources are contained primarily in bastnäsite and monazite (USGS, 2016), and bastnäsite is the main source of LREE. (Machacek and Kalvig 2017: EURARE)

**Table 171: Estimates of the global REO reserves in million tonnes**

Country	BRGM (2015)	USGS (2020)		TMR (2015)	Adamas Intelligence (2016)
Australia	2.563	3.3		3.21	4.45
Brazil	7.46	22		2.64	2.29
Canada	0.805	0.83		35.44	38.19
China	65.84	44			

<sup>235</sup> There is no single source of comprehensive evaluations for resources and reserves that apply the same criteria to deposits of fluor spar in different geographic areas of the EU or globally. The USGS collects information about the quantity and quality of mineral resources but does not directly measure reserves, and companies or governments do not directly report reserves to the USGS. Individual companies may publish regular mineral resource and reserve reports, but reporting is done using a variety of systems of reporting depending on the location of their operation, their corporate identity and stock market requirements. Translations between national reporting codes are possible by application of the CRIRSCO template.<sup>235</sup>, which is also consistent with the United Nations Framework Classification (UNFC) system. However, reserve and resource data are changing continuously as exploration and mining proceed and are thus influenced by market conditions and should be followed continuously.

Gabon					2.64
Germany				0.02	0.02
Greenland	1.528	1.5		35.57	41.3
India		6.9			
Kenya				4.25	6.14
Kyrgyzstan					0.05
Madagascar					0.57
Malaysia	0.043	0.03			
Malawi					0.58
Mozambique					0.02
Namibia					0.02
Norway				4	0.90
Russia	0.153	12			
Sweden	0.14			0.24	0.24
Turkey				0.35	0.35
Tanzania	0.94	0.89		1.77	4.63
South Africa	0.064	1.8		1.24.29	1.34
USA	1.694	1.4		4.291.2	3.93
Vietnam		22			
Other Countries		0.31		1.24	
Total	81.23	120		90.99	108

REE-enriched deposits are the result of primary (magmatic and hydrothermal) or secondary (weathering and sedimentary transport) geological processes.

A brief summary of the seven main geological types of REE deposits (Machacek and Kalvig 2017: EURARE):

**Alkaline igneous rock deposits:** In the magmatic environment, REE deposits are typically associated with alkaline igneous suites, in continental-rift tectonic environments. In highly peralkaline magmas, REE-rich oxides, phosphates and/or silicates may be concentrated at certain horizons within the magma chamber because of the incompatible behaviour of REE. Alternatively, REE may be concentrated by late stage magmatic-hydrothermal activity. Significant deposits hosted by alkaline (potassium and sodium-rich) intrusions include Lovozero (Russia), Kvanefjeld and Kringlerne (Greenland), Strange Lake and Nechalacho/Thor Lake (Canada), and Norra Kärr (Sweden). In general, REE deposits associated with alkaline igneous rocks are rather low grade, but may be large tonnage and relatively enriched in the HREE. The REE are typically hosted in complex REE-silicate minerals.

**Carbonatite deposits:** Carbonatites are unusual magmas with >50% modal carbonate minerals, most commonly found in continental-rift tectonic environments, often associated with alkaline igneous rocks. These low-degree mantle melts may contain high concentrations of REE and crystallise REE carbonates and REE fluorocarbonates (e.g. bastnäsite) as well as REE phosphates (monazite and xenotime). The carbonatite-associated deposits are dominated by LREE-enriched REE-minerals. Mountain Pass (USA), Mt. Weld (Australia), and Bayan Obo (China) constitute examples of carbonatites of which only the latter two are being exploited for REE.

**Granite and pegmatite deposits:** Granite and pegmatite-hosted REE deposits are associated with highly-evolved, residual melts formed by the fractional crystallisation of a fertile granite body. Deposits of this type were among the first sources of REE to be exploited in the early twentieth century, e.g. the Ytterby pegmatite in central Sweden. Whilst historically important, they are rarely promising exploration targets due to their small tonnage and complex mineralogy. However, they often have potential for by-products such as beryllium, fluorine and niobium.

**Vein and skarn (hydrothermal) deposits:** Vein and skarn REE deposits are characterised by mineralisation processes involving hot, aqueous solutions forming REE-bearing veins and replacement ore bodies (e.g. Bastnäs and Riddarshyttan, central Sweden). Carbonatite and/or alkaline magmatic bodies may be spatially associated and act as a metal and/or energy source. Examples of REE deposits where hydrothermal processes are recognized to have been important include Bayan Obo (China), Nolans Bore (Australia), and Steenkampskraal (South Africa).

**Iron oxide-apatite deposits of the Kiruna type** in the Svecofennian belt are also enriched in the REE due to apatite, including Kiruna and MalMBERGET in northern Sweden and the Grängesberg-Blötberget deposits in South Central Sweden (Goodenough et al. 2016). Some Iron-Oxide Copper Gold (IOCG) deposits such as Olympic Dam, Australia, carry the mineral apatite, which has the potential to produce REE as a by-product. The REE-bearing apatite is currently treated as waste during iron ore processing, there is however, as earlier mentioned, an on-going pilot-project to start a small rare earths production from iron-ore mining wastes.

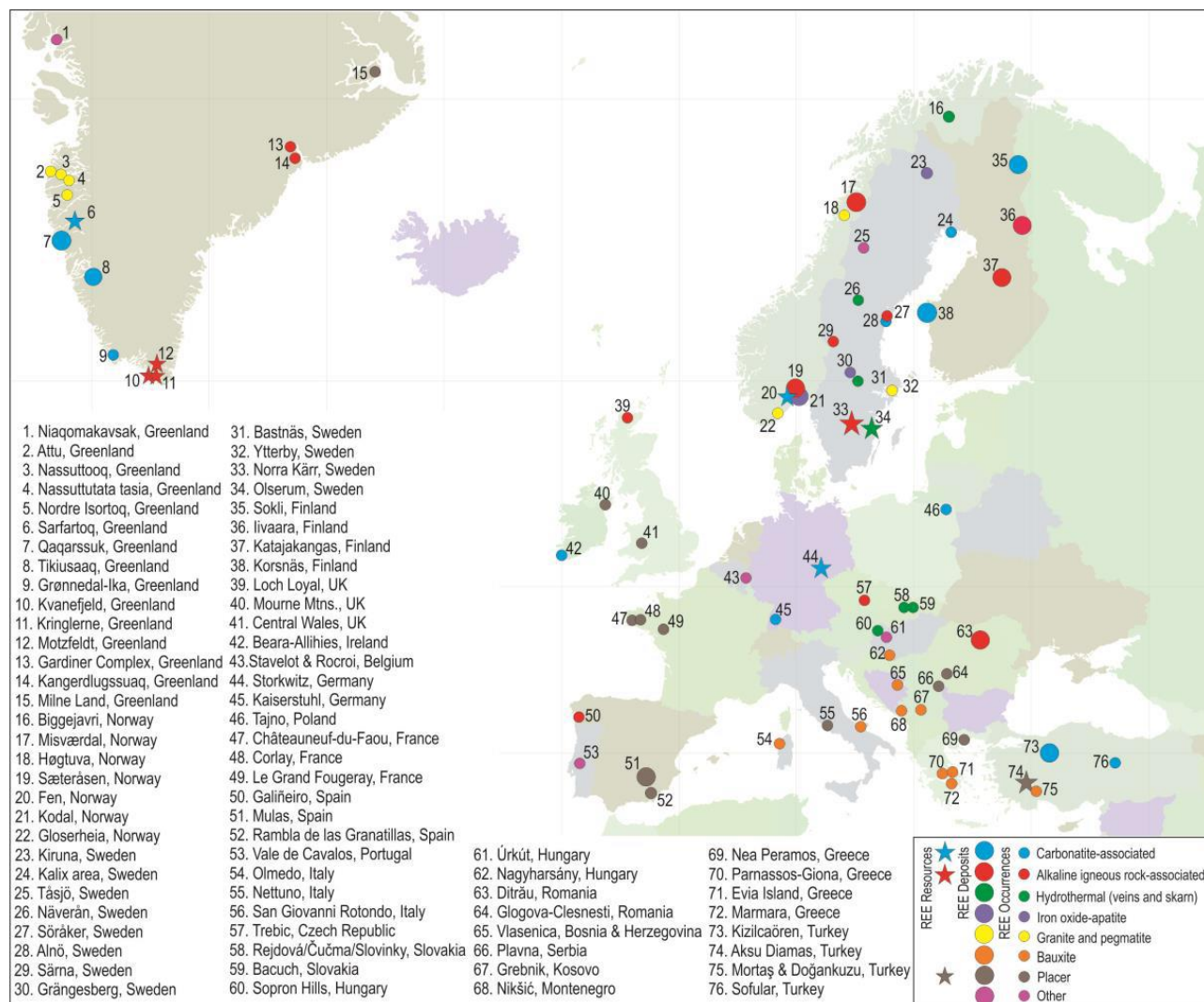
**Placer deposits:** Some of the REE-bearing minerals, such as monazite and xenotime, are relatively resistant to weathering and can be transported by sedimentary processes. As a result, they can become concentrated in heavy mineral sand deposits, referred to as placers. Such placer deposits can form in rivers, in arid environments (dunes), or in beach and shallow marine environments. Currently, mineral sand mining operations in India, Malaysia and Australia, which mine cassiterite (Sn), rutile (Ti), and/or zircon (Zr), also stock-pile monazite and/or xenotime from which REE can be produced as by-products. This deposit type is also known from the geological record (palaeo-placer) where subsequent metamorphic processes may have upgraded the REE resource (e.g. Olserum, Sweden).

**Bauxite deposits:** Accumulation of residual clay minerals on karst limestone surface followed by chemical weathering under tropical conditions can lead to the formation of bauxite deposits. This process has the potential to generate near-surface bauxite deposits due to crystallisation of authigenic REE-bearing minerals, accumulation of residual phases and the adsorption of ions on clays and other mineral surfaces (Deady et al. 2014). The Mediterranean bauxite deposits have potential to produce REE as a by-product from aluminium production (Deady et al. 2016).

**Ion-adsorption deposits:** Ion-adsorption deposits are a specific type of laterite deposit. They are formed by in-situ chemical weathering of granitic rocks, resulting in adsorption of REE to clay mineral surfaces within the laterite profile. Such ion-adsorption clay deposits

are typified by the occurrences in the Jiangxi, Guangdong, Hunan, and Fujian provinces of southern China and, despite being low-grade, are important sources for the more valuable HREE. These clay deposits are easily mined because the adsorbed REE can be released from the clays by simple acid leaching methods using leachates such as ammonium sulphate. But in general exploitation of this type has a negative environmental impact.

*EU resources and reserves*<sup>236</sup>:



**Figure 441: REE deposits in the EU according to the EURare project. (BGS NERC 2019: SCREEN)**

<sup>236</sup> For Europe, there is no complete and harmonised dataset that presents total EU resource and reserve estimates for REEs. The Minerals4EU project is the only EU-level repository of some mineral resource and reserve data for REEs, but this information does not provide a complete picture for Europe. It includes estimates based on a variety of reporting codes used by different countries, and different types of non-comparable datasets (e.g. historic estimates, inferred reserves figures only, etc.). In addition, translations of Minerals4EU data by application of the CRIRSCO template is not always possible, meaning that not all resource and reserve data for REEs at the national/regional level is consistent with the United Nations Framework Classification (UNFC) system (Minerals4EU 2019). Many documented resources in Europe are based on historic estimates and are of little current economic interest. Data for these may not always be presentable in accordance with the UNFC system. However a very solid estimation can be done by experts.

Sweden and Greenland present interesting potential for REE exploitation, although currently penalized by low market conditions or environmental issues. The Minerals4EU website only provides some data about Yttrium lanthanide and yttrium ore reserves in Ukraine, at about 417 kt (RUS A) (Minerals4EU, 2019). However, only Greenland and Sweden assessments of rare earths reserves (respectively 1,528,000 tonnes and 140,000 tonnes of REO – see Table 172) have been performed using international reporting code and can be qualified as reliable at the present date.

**Table 172: REE exploration projects in EU in a harmonized UNFC format (based on responses from EU RMSG in 2019)**

Countries	Projects	Commercial projects (E1; F1; G1,2,3) <sup>1</sup>	Potentially commercial projects (E2; F2; G1,2,3) <sup>1</sup>	Non-Commercial projects (E3; F2; G1,2,3) <sup>1</sup>	Exploration projects (E3; F3; G4) <sup>1</sup>	E3, F4, G1, G2
		Estimate of quantities (tonnes, REO)				
Finland	Katajakangas			11040		
	Kontioaho			34605		
	Korsnas					7740
	Konvela		1160			
Germany	Storkwitz		9900			
	Storkwitz		9900			
Greenland	Kringlerne		28200000			
	Kvanefjeld	632100				
	Kvanefjeld	896000				
Norway	Fen			907200		
	Kodal			756000		
	Misværdalen			21000		
Portugal	Vale de Cavalos				10320	
Spain	Matamulas		35890			
	Gemas, Tesorillo			25000		
Sweden	Norra Kärr		202519			
	Grängesberg				280000000	
	Olserum		27000			
	Olserum		20790			
	Tasjo		82500			

#### *Importance of REE mineralogy*

The REE can be incorporated into a range of different mineral types, such as carbonates, oxides, silicates, phosphates, each of them related to specific geological environments. More than 200 REE-bearing minerals have been identified (Kanazawa and Kamitani, 2006), though only a few are currently considered feasible for the extraction of REE. Bastnäsite (carbonate mineral), is currently the most important REE ore mineral and is extracted at the Chinese mining operations in Bayan Obo, Weishan and Maoniuping, and until 2015 was also mined at Mountain Pass (USA). Monazite and xenotime (phosphate minerals), and loparite (oxide mineral) are also exploited.

Research on processing technologies for many other minerals is currently under way. More recently, a number of REE exploration targeted the alkaline igneous deposits that contain less conventional REE silicate ore minerals such as eudialyte, gadolinite, fergusonite and steenstrupine. These minerals can be of interest because of their more balanced ratio of HREE to LREE which makes them a potentially highly valuable resource, but they were traditionally considered unsuitable for recovery due to their resistance to dissolution (Binnemans and Jones, 2015).

1.4 million tonnes of red mud waste generated annually in the EU by alumina production from 3.5 million tonnes bauxite through the Bayer process may also be interesting alternative, containing on average 900 ppm REE compared with typical values of <100 ppm to ~500 ppm REE in bauxites. (Deady et al. 2014)

Similarly, phosphates are a perspective source of REE, for example the EU project SecREEs aims to unlock potential of REE in 650,000 tons of phosphate rock mined annually in Norway, containing about 0.3 -1.0 percent of REE.

The REE ore grade impacts on the economic viability of each deposit. REE-distribution can be even more important than the REE-grade. There is an oversupply of cerium and lanthanum, while there is a demand for REE used in magnets (Pr, Nd, Sm and Dy), and phosphors (Eu, Gd, Tb and Y ).

Each of the REE-minerals has a characteristic REE-ratio (Kanazawa and Kamitani, 2006), e.g. bastnäsite and monazite are dominated by LREE, whereas xenotime is relatively rich in HREE. Substantial variations in REE-distribution can occur within one type of REE-mineral, e.g. the eudialyte minerals from Kringlerne, Kipawa and Norra Kärr, or bastnäsite in Bayan Obo, China and Mountain Pass, USA have different REE-compositions.

Presence of radioactive elements, mainly uranium and thorium are addressed in the chapter on Environmental, health and safety issues.



**Table 173: Some of the most common REE minerals (Wall, 2014) (Machacek and Kalvig 2017: EURARE).**

Mineral	Formula	Wt.% REO	Th, U	Other REE variant
<b>Carbonates and fluorcarbonates</b>				
Ancylite (Ce)	SrCe(CO <sub>3</sub> ) <sub>2</sub> (OH)H <sub>2</sub> O	43	-	La
Bastnäsite (Ce)	CeCO <sub>3</sub> F	75	-	La, Nd, Y
Huanghoite (Ce)	BaCe(CO <sub>3</sub> ) <sub>2</sub> F	40	-	
Parisite (Ce)	CaCe(CO <sub>3</sub> ) <sub>3</sub> F <sub>2</sub>	50	-	Nd
Synchysite (Ce)	CaCe(CO <sub>3</sub> ) <sub>2</sub> F	51	-	Nd, Y
<b>Phosphates</b>				
Apatite	Ca <sub>5</sub> (PO <sub>4</sub> ) <sub>3</sub> (F, Cl, OH)	-	-	-
Cheralite	CaTh(PO <sub>4</sub> ) <sub>2</sub>	Variable	M	
Churchite (Y)	YPO <sub>4</sub> · 2H <sub>2</sub> O	51	V	Nd
Florencite (Ce)	(Ce)Al <sub>3</sub> (PO <sub>4</sub> ) <sub>2</sub> (OH) <sub>6</sub>	32	-	Sm
Monazite (Ce)	CePO <sub>4</sub>	70	V	La, Sm, Nd
Xenotime (Y)	YPO <sub>4</sub>	61	V	Yb
<b>Oxides</b>				
Aeschynite (Ce)	(Ce, Ca, Fe, Th)(Ti, Nb) <sub>2</sub> (O, OH) <sub>4</sub>	32	V	Nd, Y
Cerianite (Ce)	CeO <sub>2</sub>	100	V	-
Loparite (Ce)	(Ce, La, Nd, Ca, Sr)(Ti, Nb)O <sub>3</sub>	30	-	
Yttropyrochlore (Y)	(Y, Na, Ca, U) <sub>1-2</sub> Nb <sub>2</sub> (O, OH)	17	V	
<b>Silicates</b>				
Allanite (Ce)	CaNdAl <sub>2</sub> Fe <sub>2</sub> +(Si <sub>2</sub> O <sub>7</sub> )O(OH)	23	V	La, Nd, Y
Britholite (Ce)	(Ce, Ca, Sr) <sub>2</sub> (Ce, Ca) <sub>3</sub> (SiO <sub>4</sub> PO <sub>4</sub> ) <sub>3</sub> (O, OH, F)	23	V	Y
Eudialyte	Na <sub>15</sub> Ca <sub>6</sub> Fe <sub>3</sub> Zr <sub>3</sub> Si(Si <sub>25</sub> O <sub>73</sub> )(O, OH, H <sub>2</sub> O)(Cl, OH) <sub>2</sub>	9	-	
Fergusonite (Ce)	CaNdAl <sub>2</sub> Fe <sup>2+</sup> (SiO <sub>4</sub> )(Si <sub>2</sub> O <sub>7</sub> )O(OH)	53	-	Nd, Y
Gadolinite (Ce)	Ce <sub>2</sub> Fe <sup>2+</sup> Be <sub>2</sub> O <sub>2</sub> (SiO <sub>4</sub> ) <sub>2</sub>	60	V	Y
Gerenite (Y)	CaNdAl <sub>2</sub> Fe <sup>2+</sup> (SiO <sub>4</sub> )(Si <sub>2</sub> O <sub>7</sub> )O(OH)	44	-	Y
Kainosite (Y)	Ca <sub>2</sub> Y <sub>2</sub> (SiO <sub>3</sub> ) <sub>4</sub> (CO <sub>3</sub> )H <sub>2</sub> O	38	-	
Keiviite (Y)	Y <sub>2</sub> Si <sub>2</sub> O <sub>2</sub>	69	-	Yb
Steenstrupine (Ce)	Na <sub>14</sub> Ce <sub>6</sub> (Mn <sup>2+</sup> ) <sub>2</sub> (Fe <sup>3+</sup> ) <sub>2</sub> Zr(PO <sub>4</sub> ) <sub>7</sub> Si <sub>12</sub> O <sub>36</sub> (OH) <sub>23</sub> H <sub>2</sub> O	31	V	
<b>Fluorides</b>				
Fluocerite (Ce)	CeF <sub>3</sub>	83	-	La

## *Alternative sources of rare earth elements in Europe*

### *Benchmarking REE-exploration projects*

The steps involved in developing a REE project from the discovery of the occurrence, through exploration, to a mine, follow the same principal pathway as other types of metal exploration projects, though traditional geophysical methods cannot be applied if the occurrence is not genetically associated to sulphide systems. Once mineralization is recognized, the ore- and gangue minerals need to be identified and their textures studied, and mapping and drilling are carried out to define the resources at the project. Pilot studies for beneficiation and extraction will be carried out where appropriate; pre-feasibility and final feasibility studies will take place along with environmental assessments.

Exploration and development of a REE-deposit is very challenging, given the fact that each deposit is a multi-element deposit typically with a complicated mineralogy, which will require development of tailor-made beneficiation and cracking flow-sheets. REE-distribution is key to market acceptability and, consequently, to economics of a REE-deposit. In most metal exploration projects, the grade and the price of the main metal are the key parameters for evaluating an exploration project's feasibility to be further developed. For REE deposits evaluation is more complex, and a wide range of parameters can be used to evaluate the potential of any given REE project; some of these are directly related to the deposit mineralogy.

### The Criteria for a Sustainable Economically Sound Rare Earths Project (Kingsnorth 2018)

- Ore grade (%), meaning the REE content of one unit of the ore;
- Ore tonnage, meaning the volume of the ore (the economic part of the rock hosting REE-minerals)
- Composition of the REE mineral: the mis-match between the ratio of the rare earths produced and those consumed is a major issue for the industry. Accordingly, given the high growth in demand for neodymium and praseodymium it is desirable that the composition of a project's rare earths ores are high in these elements. High concentrations of lanthanum and cerium are a 'problem' as a significant proportion of these elements are discarded. Normally, no value is attributed to the five HREE with limited, niche markets (Ho, Er, Tm, Yb, Lu).
- Individual REE-grade (%) based on the individual REE as a fraction of REE, frequently expressed as HREE/LREE-%, reflecting the REE-distribution.
- Ore value or gross metal value (GMV): REO-value per unit mass of mineral resource (EUR/tonne), reflecting the in-situ value of the ore material, thus considering the ore grade, but not the tonnage and recovery of the ore. A high-grade ore dominated by LREE may reach a lower GMV than a low-grade ore dominated by HREE. Further, high GMV does not guarantee a market for the products.
- Basket price (EUR/kg), reflecting the potential price if one kilogram of the REO is extracted from the ore – not accounting for the ore grade or the total recovery rates. From this it follows that low grade ore may well result in high basket price and vice versa.
- Mineralogy of the ore: To date there have only been 4 minerals (bastnastite, monazite, xenotime and the ionic clays in China) that have been successfully processed commercially. It has taken Alkane Resources over 10 years of pilot plant work to

develop a potentially commercial process for the extraction of rare earths, zirconium, hafnium and niobium from the eudialyte at Dubbo, New South Wales, Australia.

- Pilot plant: The successful operation of a pilot plant is required to demonstrate the technical, financial and social viability of a project. The operation will provide samples for customer approval, while providing the required data for the estimation of capital and operating costs.
- Demonstrable Radioactivity and Environmental Management: All rare earth ores contain some uranium and thorium so it is incumbent on the project developer to demonstrate that this aspect of the project is manageable.
- Realistic start-up schedule: including adequate working capital.
- Marketing: The marketing plan must be realistic in terms of market share and product quality.

It should be noted that, as a result of poor market transparency, there is no standard set of prices for the REE-commodities, and thus metrics such as GMV and basket price are both dynamic parameters and may reflect company views.

In the calculations of GMV and basket price the following parameters are not accounted for: (i) deposit tonnage; (ii) costs associated with mining, extraction, and separation; (iii) mineralogy and processing level of difficulty; (iv) recovery loss (assumes 100% REO recovery from ore to final product, which is unfeasible); (v) specifications and salability of final products; and (vi) project economics (e.g. OPEX, CAPEX, IRR, NPV).

In some economic analyses a percentage discount is applied to the product sales price(s) reflecting the intent of final sale to be a mixed concentrate product (RE-oxides, RE-carbonate; RE-chloride), as opposed to separated REOs for which a price deck applies. Given that all REE projects will need to produce an intermediate product feed to the separation facility, project to project comparison could be based on prices for the mixed concentrate product. Alternatively, a tolling price would need to be added to the OPEX (mining through to mixed REO concentrate) to approach a possibility for comparison; though these cost figures most likely would be available only when an off-take contract has been signed with a separation facility operator. However, in order to compare REE projects, it is vital that they are all assessed to the stage of a common product. A project that intends to sell a mixed REE-carbonate will appear very different economically to one that has an REE separation facility on site.

#### **21.4.3.2 World and EU mine production**

##### *Global mine production*

According to USGS (2020) the global mine production of REO equivalent in 2019 reached 210,000 tonnes.

China official mine production quota for REO in 2019 was 132, 000 tonnes, which is over 60% of global production, compared to 120,000 tonnes in 2018, and 105,000 tonnes in 2017. Additional undocumented annual production in China is estimated at 60,000-80,000 tonnes (Kingsnorth, 2018). ACREI (2019) reports that the production capacity of the six Chinese rare earth producers was 227000 tons in 2018, while the capacity of the whole industry including comprehensive recycling of rare earth resources was estimated to be about 300,000 tonnes.

After a break in 2015-2017, US restarted mining in Mountain Pass reaching 18,000 tons in 2018, and 26,000 t in 2019 (USGS, 2020). But their ores and concentrates are shipped to China for refining, from where it sources 80% refined rare earths. In 2019, Australia mined 21,000 tonnes of REO, Myanmar 22000 tonness, India 3000 tonnes, Russia 2,700 tonnes and Madagascar 2,000 tonnes and Thailand 1,800 tonnes. Brasil, Burundi, Malaysia, Vietnam and other countries produced 1000 tonnes or less (USGS, 2020).

As shown in the following table, there is an issue with existing statistics due to confusion between REE and REO, as well as inconsistency with respect to the commodities included; e.g. in some cases REE-mineral concentrates are included, in other cases not. (Machacek and Kalvig 2017: EURARE)

**Table 174: Variation in REE mine production statistics (2014) (USGS,2016; Brown et al., 2016; Adamas Intelligence, 2016) (Machacek and Kalvig 2017: EURARE)**

Country	Mine production (2014) (ton) USGS (2016)	Mine production (2014) (ton) Brown et al. (2016)	Mine production (2014) (ton) Adamas Intelligence (2016)
US	5,400	4,200	
Australia	8,000	3965	7,191
Brazil	-		94
China (legal)	105,000	95,000	104,000
China (illegal)			24,500
India	NA		-
Malaysia	240	221	167
Myanmar			2,472
Russia	2,500	2,134	2,093
Thailand	2,100		-
Other	NA		5,908
<b>Total</b>	<b>123,240</b>	<b>105,519</b>	<b>146,425</b>

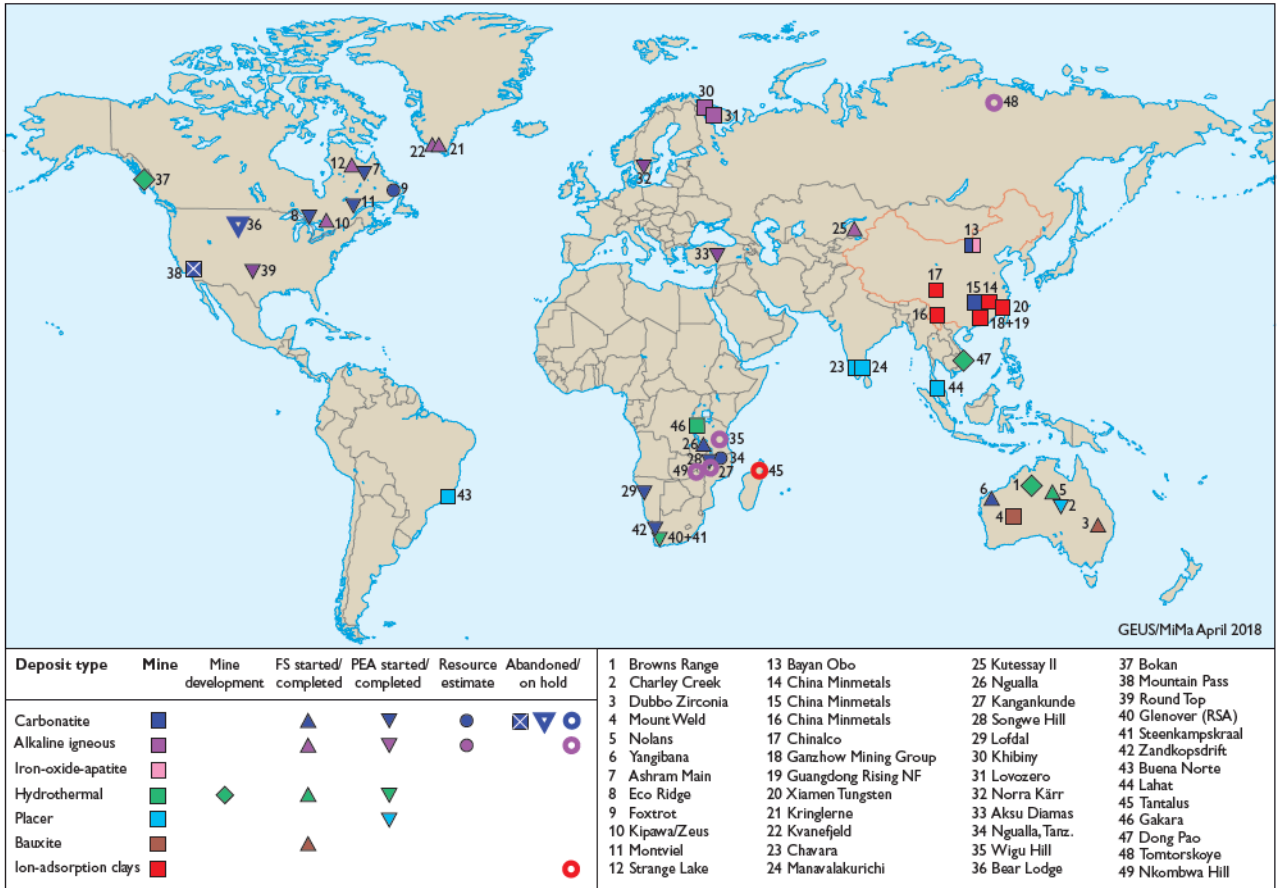
*“The main discrepancy in the annual production statistics may be due to the illegal operations which are in general not included, except for Admas Intelligence, 2016. The extensive contribution to the mine production is supported by Kingsnorth (2016), estimating the illegal figure to be about 30% of the national production quotas.*

*Development of new REE operations outside China is facing strong competition from the state-controlled and vertically integrated Chinese REE-industry, which controls the REE-supply chain from mining to manufactured goods. Outside China, only two new producers of primary REE have begun production in the past five years – Lynas Corp at Mount Weld, Australia, and Molycorp at Mountain Pass, USA, of which the latter went bankrupt in 2015, and operations suspended in 2016.” (Machacek and Kalvig 2017: EURARE)*

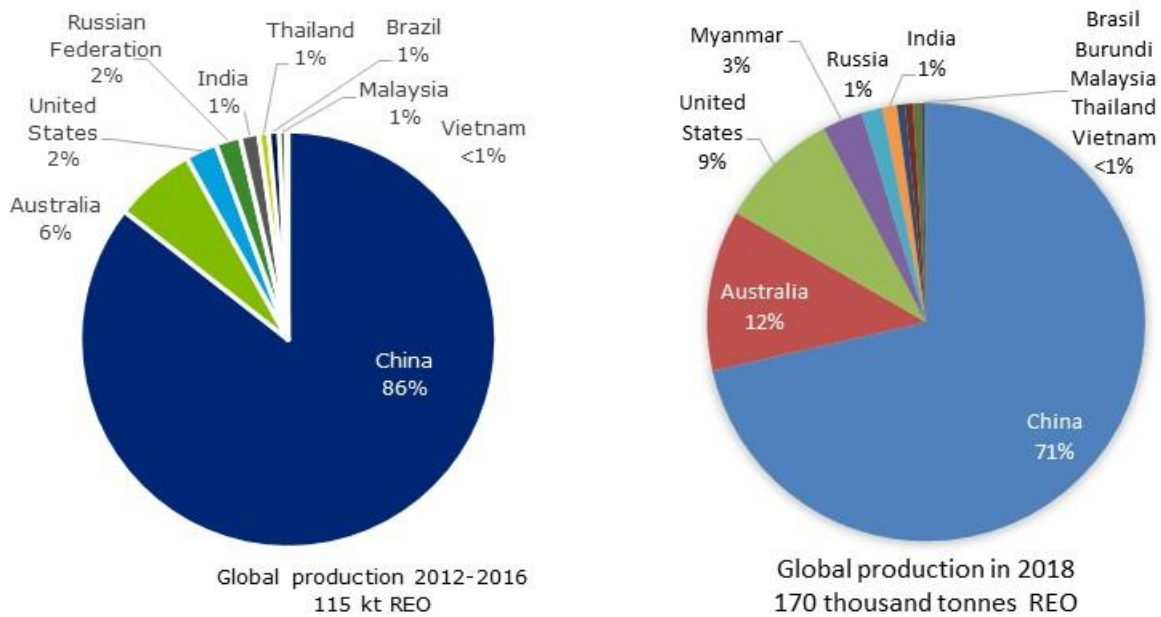
**Table 175: World REE-mining companies (Adamas 2015; Jesper Zeuthen, pers. Comm. Oct. 2016) (Machacek and Kalvig 2017: EURARE)**

Country	Company	Mine/ Region	Geol. type	Capacity (REO tpa)	LREE/HREE enrichment	Product
Australia	Lynas Corp	Mount Weld	Carb./laterite	22,000	LREO	Mixed and separated REO
Brazil	Nuclear Industries of Brazil	Buena Norté		1,500	LREO	Mixed and separated REO
China	Baotou Steel Rare Earth Co <sup>237</sup>	Bayan Obo	Carbonatite	59,500	LREO	Mixed and separated REO
China	Jiangzi Copper Rare Earth	Maoniuping	Carbonatite	2,500	LREO	Mixed and separated REO
China	Minmetals Ganzhou Rare Earth Co.	Jiangxi	Ion-adsorp.	9,000	HREO	Mixed and separated REO
China	Xiamen Tungsten Co.	Fujian	Ion-adsorp.	2,000	HREO	Mixed and separated REO
China	Guangdong Rare Earth Industry Group	Guangdong	Ion-adsorp.	2,000	HREO	Mixed and separated REO
China	Chinalco Rare Earth Co.	Guangzi	Ion-adsorp.	2,500	HREO	Mixed and separated REO
China	China Minmetals Rare Earth Co.	Hunan	Ion-adsorp.	2,000	HREO	Mixed and separated REO
China	China Iron and Steel Research Institute Group	Weishan	Ion-adsorp.	2,600	HREO	Mixed and separated REO
China	China Minmetals Rare Earth Co.	Yunnan	Ion-adsorp.	200	HREO	Mixed and separated REO
India	Indian Rare Earth Ltd	Tamil Nadu	Placer	2,800	LREO	Mineral concentrate
India	Kerala Metals and Minerals	Kerala	Placer	240	LREO	Mineral concentrate
Malaysia	Pegang Mining Co.	Kinta Valley	Placer	100	LREO	Mineral concentrate
Russia	Lovozerkiy GOK	Lovozero	Alkaline	2,400	LREO	Mineral concentrate
USA	Molycorp (operation restarted in 2018)	Mountain Pass	Carbonatite	26,000	LREO	Mixed and separated REO
Vietnam	Lavreco/Sojitz/Toyota	Dong Pao	Placer	220	LREO	Minex and separated REO

<sup>237</sup> The company plans to amalgamate with Gansu Rare Earth Group to consolidate the nation's northern mining, separating, and processing operations under the umbrella of a new organization called China North Rare Earth High Tech Corporation.



**Figure 442: Major global rare-earth element mines and advanced exploration projects (GEUS/MiMa, 2018) (Machacek and Kalvig 2017: EURARE).**



**Figure 443: Global mine production of REOs, average 2012–2016. No EU mine production of rare earths. Compilation of data (World Mining Data 2018, USGS 2019)**

Kingsnorth (2013, 2018) reported on undocumented extraction of REE in China, which at some periods could have accounted for 30-40% of Chinese production. USGS reported that according to China's Ministry of Commerce, production of REO in China in 2018 was estimated to be at least 180,000 tons based on magnet material production, including undocumented production.

**Table 176: Global production of REO (WMD 2019 and USGS 2016<sup>1</sup>; Roskill 2019<sup>2</sup>)**

REE		Production (t) <sup>1</sup>	% of global production <sup>1</sup>	Production (t) <sup>2</sup>	% of global production <sup>2</sup>
<i>LREE</i>	La	28,328	24.5	45,469	25.0
	Ce	51,167	44.3	76,677	42.1
	Pr	5,413	4.7	9,757	5.4
	Nd	18,214	15.8	30,687	16.8
	Sm	2,498	2.2	3,041	1.7
	total LREE	105,620	91.5	165,631	90.9
<i>HREE</i>	Eu	422	0.4	364	0.2
	Gd	1,596	1.4	2,431	1.3
	Tb	206	0.2	400	0.2
	Dy	1,018	0.9	1,397	0.8
	Er	484	0.4	830	0.5
	Y	5,413	4.7	10,414	5.7
	Ho, Tm, Lu, Yb	660	0.6	727	2.7
	total HREE	9,799	8.6	16,563	9.1
<b>Total</b>	<b>115,419</b>	<b>100</b>	<b>182,194</b>	<b>100</b>	

As there is no data available at the global level for individual production of REE, individual figures of REE production were obtained relying on several sources and hypotheses (BGS, 2016; BRGM, 2015; Bio Intelligence Service, 2015; Roskill 2019).

Most REE mines, such as Bayan Obo, Mountain Pass and Mount Weld, are open-cast operations, involving conventional blast, and load and haul techniques. No underground mines have ever been designed for the exclusive production of REE but there are, or has been, production of REE from a few underground mines. For example, the former thorium mine at Steenkampskraal, South Africa, and the former uranium mines at Elliot Lake, Ontario, Canada.

Different mining techniques are used for the beach sand placer deposits because they are generally much less consolidated than carbonatites, alkaline rocks or hydrothermal deposits. They are also often under water. Mining techniques include dredging and excavation by bucket wheel or by excavator. Some crushing may be required.

There are few details available of mining techniques for ion adsorption deposits in China but many are small-scale operations, with much of the mining done by manual labor. The clay deposits are excavated and leached to extract REE, mostly using in-situ leaching techniques, sometimes on large areas.

Some ores are mined as the main product from hard-rock deposits (e.g. Lovozero, Russia); some are mined as by-products from large-scale iron mining operations as in Bayan Obo, China; some are extracted as by-products from heavy-mineral sand dredging operations, such as

Manavlakurichi and Chavara in India; and some are leached out from ion-adsorption clay deposits, e.g. Xunwu/Longnan in South-East China.

All REE-ores must be beneficiated to produce a REE concentrate. Each deposit will need a specific flow-sheet for the physical and chemical techniques and technology tailored to the particular operation, aimed for producing either REE-mineral concentrate or mixed REE-concentrate. Most REE operations currently follow one of three general routes:

1. *Hard-rock mining* (underground/open-pit): Drilling – blasting – hauling – crushing – milling – mineral separation – cracking the REE-bearing mineral
2. *Dredging operation*: Excavation – mineral separation – cracking the REE-bearing mineral
3. *Leaching operation*: Leaching ion-adsorption clay – collecting the pregnant solution.

Other procedures are also in development, for example for the extraction of REE as a by-product of aluminium production.

Typical techniques for beneficiation of hard-rock ores start with crushing and milling, where the ore is ground down to fine particles in order to free the REE-mineral(s) from the gangue minerals in the ore. For heavy mineral sands, crushing and milling may not be required. This stage is followed by specific treatments typically based on physical and chemical properties of the mineral, e.g. separation by gravity, flotation, magnetics, color or electrostatic separation technologies. The beneficiation product is a REE-mineral concentrate, which will subsequently be dissolved (cracked) in order to extract the REE. REE-mineral concentrates of some of the common REE-minerals, e.g. bastnäsite ((La, Ce)  $\text{FCO}_3$ ), xenotime ( $\text{YPO}_4$ ) and monazite ((Ce, La, Y, Th)  $\text{PO}_4$ ), for which routine cracking procedures exist are considered commercial products. This is currently not the case for less conventional REE minerals (e.g. eudialyte, synchisite, gadolinite, fergusonite, loparite and steenstrupine) for which no standard cracking procedures are available. However, in particular eudialyt, has been subject to new hydrometallurgical treatment tests as part of the EURARE project, (Davris *et al.* 2016) and may well make it possible to turn eudialyte-concentrates into commercial products in the future.

Most mining operations aim at adding as much value as possible to the product prior to shipment as well as reducing the amount of volume to be shipped. Therefore cracking is frequently done on the plant-site, producing a mixed REO-carbonate as the commercial product. Subsequently, the individual REE will need to be separated from this mixed product (see below).

For both route 1 and 2, the discharge composed by the gangue minerals forms the tailings. Mining REE as main products will frequently produce a tailings volume equivalent to 95% plus of the mill-feed; considering some of the advanced REE-projects this could amount to 1-3 Mtpa. Tailings may possess environmental risks and are therefore stored in large tailings-dams or used as back-fill in underground mines. Research conducted within the EURARE project assesses these environmental risks, with respect to radiogenic contents.

Ion-adsorption clays are typically leached with sodium chloride or  $\text{HNO}_3$  and the leaching can be executed either in-situ, or as heap- or tank leaching. The ease of mining and processing compensates for the comparatively low grade of these 'ores'; it is not uncommon for 2-3,000 tons of clay to be mined and treated to recover one ton of REO. However, both methods have significant environmental consequences and the resultant environmental degradation in those areas where the ores are mined and processed has forced the Chinese government to implement strict environmental management standards (Roskill, 2011).

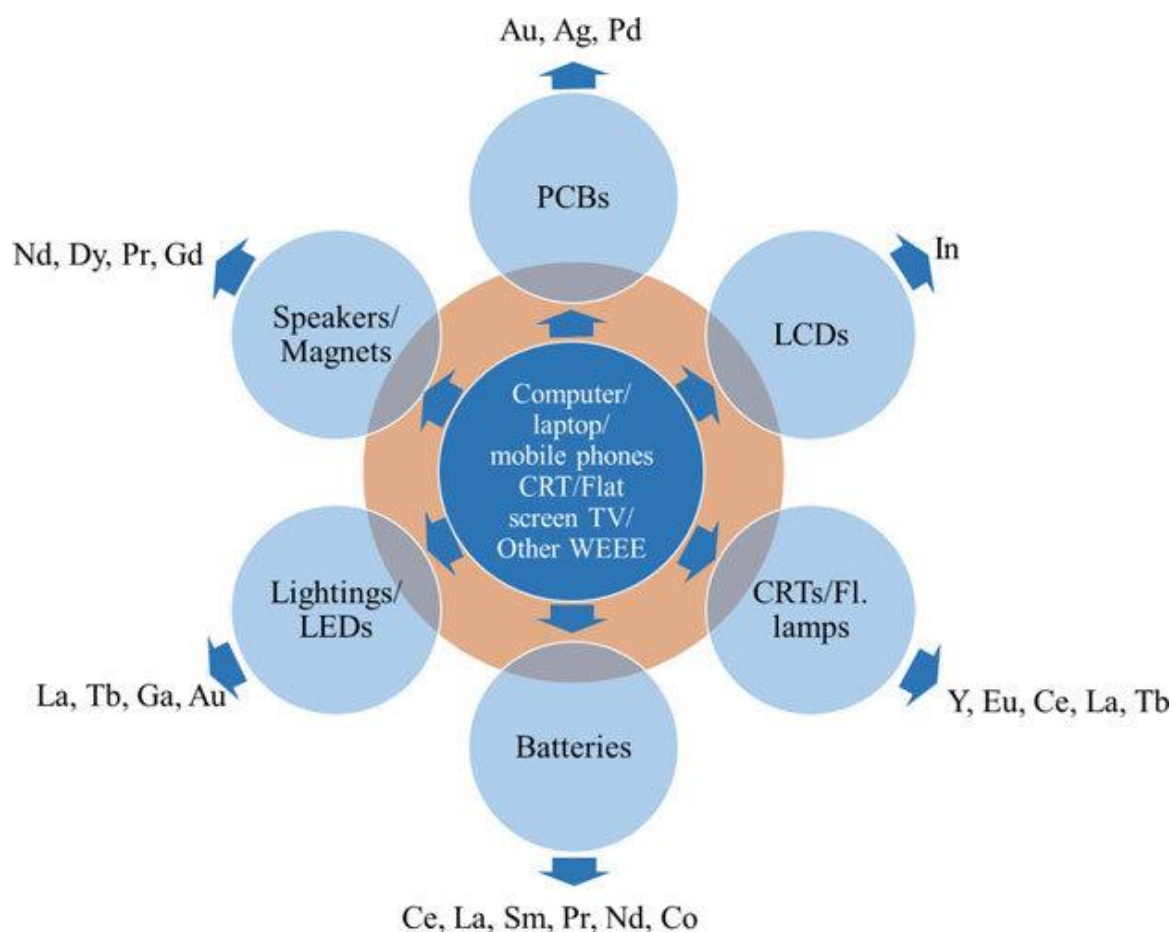


### EU mine production

The EU has no mining of rare earths, but imports ores and concentrates for refining. An iron ore producer - LKAB in Sweden, and phosphates fertilisers producer - Yara in Norway, currently develop processes to start a small rare earths production from their mining wastes. Potential exists also in coal and aluminium ore mining wastes.

### 21.4.4 Supply from secondary materials/recycling

Recycling R&D on new processes were initiated in 2011 in a context of high prices and uncertainty of supply, when China announced a reduction of export quotas. There are several groups of products providing potential for recycling of REE, such as neodymium, dysprosium, praseodymium, samarium, gadolinium, europium, terbium, but also cerium and lanthanum.



**Figure 444: Example of different types of WEEE and potential for recycling raw materials, including rare earths. (Sethurajan et al., 2019)**

Today, recycling input rate is still very low, usually under 1%, especially in Europe because of the lack of efficient collecting systems and prohibitive costs of building REE recycling capacities (ERECON, 2014). Higher recycling input rates for europium, yttrium and terbium are reported only thanks to recycling of fluorescent lamps.

Rhodia-Solvay, one of the main REE-based phosphors producers in the EU developed a recycling unit together with Umicore in France in 2012, but had to stop operations by January 2016 because it had become uneconomic (Delamarche, 2016). Solvay still produces several REE products, such as gadolinium, lutetium and yttrium oxides, cerium oxides and hydroxides, and

neodymium versatate and neodymium phosphate used in chemical, medical, nuclear, glass and electronic applications. However, a lot of research projects are on-going to identify the best targets and processes (ERECON, 2014)

Recycling is often difficult because of the way that REE are incorporated as small components in complex items or are part of complex materials. The processes required are energy intensive and complex (Schüler et al., 2011).

Nevertheless, as for many metals, new scraps generated during the manufacture of alloys are an important secondary source, mainly in a closed loop (30% of magnet alloys end up in scraps during manufacture) (Higgins, 2016).

End-of-life recycling input rate of individual REE are summarized in Table 177.

**Table 177: EOL-RIR of individual REE (1 - UNEP, 2013; 2 - Bio Intelligence Service, 2015; 3 - BRGM, 2015)**

REE	LREE					HREE						
	Ce <sup>1</sup>	La <sup>1</sup>	Nd <sup>2</sup>	Pr <sup>3</sup>	Sm <sup>1</sup>	Dy <sup>2</sup>	Er <sup>1</sup>	Eu <sup>2</sup>	Gd <sup>1</sup>	Ho, Tm, Lu, Yb <sup>1</sup>	Tb <sup>2</sup>	Y <sup>2</sup>
End of life recycling input rate (EOL-RIR)	1%	1%	1%	10%	1%	0%	1%	38%	1%	1%	6%	31%

#### 21.4.4.1 Magnets

Permanent magnets are the main secondary resources for the recovery of neodymium, praseodymium, dysprosium and samarium.

Swarf coming from shaping and cutting of the final magnet is a potential source of secondary materials, although its exploitation at large scales is hindered by some issues, such as: the swarf often needs further treatment steps before being introduced in the formulation of new magnet alloys, mainly because of its content in dysprosium or in other alloying elements; improvements in cutting tools and relative yields are lowering the availability of swarf as source of secondary materials.

Magnets extraction technology from the end-products has been already developed, but further improvements required to efficiently separate and recover REE from the magnets: in this latter field, several industries from Japan, as well as the French industry Rhodia-Solvay, have developed processes, but mainly targeting a technology to recover REE from magnets used in air-conditioning units (Roskill, 2016).

Two different methodologies have been developed for the recycling of end of life permanent magnets containing REE (Samouhos et al. 2019: SCRREEN).

The first, called direct recycling process, aims to the magnets reuse after their demagnetization, thermal treatment and re-alloying by the addition of extra amount of pure REE in the end of life material. The low environmental impact consists the main advantage of the direct recycling process. Researchers at the University of Birmingham optimised the direct recycling of NdFeB magnets via hydrogen decrepitation technology.

The second recycling methodology concerns the elemental recovery of Nd, Pr, Dy and Sm through classic hydro and pyro metallurgical techniques. Delft University developed a metallurgical route which is based on scrap leaching and REE extraction through selective precipitation. Several technological barriers should be overcome prior to the commercialization of REE extraction by EoL magnets. The most significant are: (a) the automation of magnets dismantling, (a) the reducing of leaching environmental impact and (c) the effective separation/purification of REE in the leachate.

Some bottlenecks appear in the efforts to recover and recycle of REE from magnets:

- Efficient collection schemes are not available
- Target products contain small-size magnets, which are difficult to be recovered
- The wide variety in magnets composition complicates the set-up of generic recycling schemes;
- The low REE prices in 2012 slowed down the research into magnets recycling.

An important boost to magnets recycling could come from the expansion of the market associated to large-size NdFeB magnets for wind turbines and HEVs: although the major size of such kinds of magnets makes their collection easier, their long life span (around 25 years) significantly impacts on the time in which a real recycling of the recovered magnets into lower-power applications can be carried out (Roskill, 2016).

#### **21.4.4.2 Batteries**

Several processing technologies have been developed by Japanese (e.g. Toyota, Honda) and European companies (e.g. Umicore, Rhodia-Solvay) aiming at recycling of REE, from NiMH batteries, as well as to reuse batteries in different applications. E.g. Toyota in 2013 promoted a system to reuse NiMH automotive batteries in stationary applications for residential use. However, the long lifespan (7-10 years) of NiMH batteries makes the lag time between sale and recovery of REE quite long, thus limiting the efficient implementation of recycling solutions at large scales (Roskill, 2016).

The recovery of metallic neodymium and praseodymium from metal hydride and Li-ion batteries has been commercially attempted by limited number of European companies. The recovery of Nd, Pr, Dy and Sm from EoL permanent magnets via numerous novel processes is described in literature. These processes have been successfully tested at laboratory or pilot scale, using shredded scrap that is pure and is composed by single devices. The investigation of Nd, Pr, Dy and Sm recovery at actual conditions using multi-composed scrap is necessary in order for the recycling sustainability to be proved. (Samouhos et al. 2019: SCREEN)

#### **21.4.4.3 Catalysts**

The large amount of REOs (up to 4 wt% according to the features of the petroleum treated) contained in the FCC catalysts represents a valuable potential for recycling. Currently some research activities are moving in the REE recycling in FCC sector (Innocenzi et al., 2014; Zhao et al., 2016).

It is an open question whether a recovery of the REE (mostly La) from FCC catalysts could be interesting from an economic point of view in the next years. This is mainly depending on the price development of La (ÖkoÖko Institut, 2011). La/Ce Recycling will not be feasible as with rising volumes mined for NdPr, Ce/La gets more abundant (Balance problem of RE separation).

Currently, recycling activities on catalysts from the automotive sector are based only on the recovery of platinum group metals (PGM) from catalytic converters. "Cerium oxide is not commercially recovered from catalytic converters; instead, it is sent to landfills along with the waste produced by processing the monoliths for their PGM content" (Biswas, 2013).

The recycling of catalytic converters will continue to rely on the economic viability of recovering their PGM content (Biswas, 2013). There are currently no commercially viable technologies to recover the cerium content of catalytic converters (Biswas, 2013).

#### **21.4.4.4 Polishing:**

Within the same approach, polishing industry developed solutions enabling the recovery and re-use of slurries from polishing operations: this led to the implementation of recycling steps within several polishing plants.

Regarding secondary supply of cerium, recycling has developed for polishing powders since 2011, mostly in Japan, where cerium can be re-used in the form of mishmetal (BRGM, 2015).

#### **21.4.4.5 Glass**

Recycling: The small amounts of REE required in each glass product, as well as the large number of different products in which REE are used, make collection and recycling in glass industry an economic challenge.

#### **21.4.4.6 Phosphors**

Phosphors originated from end-of-life LCDs, computers, X-ray tubes, light bulbs and TV-sets is a significant secondary resource of yttrium. Yttrium is currently industrially extracted from various electric and electronic scrap materials in EU (Rhodia-Solvay, Narva Light Sources GmbH, Eco Recycling in Northern Italy).

Europium, terbium and yttrium from end-of-life lamps had been recycled at the Rhodia-Solvay plant in La Rochelle from 2011 until its closure in 2016 (Usine Nouvelle, 2016). Rhodia-Solvay developed a patented process (2012) to recover and recycle REE from fluorescent lamps; recovering up to 95% of REE contained in a fluorescent lamp (Walter, 2011). The plant reached its full capacity (i.e. 2,500 tpy of processed power) in 2013 (Binnemans et al., 2013c). Around 2011, primary europium oxide, terbium oxide and yttrium oxide were expensive (around 5,900 \$/kg for europium oxides, and 5,000 \$/kg for terbium oxides, ) (BRGM, 2015) and there was a demand for cheaper, recycled the rare earth oxides. However, by 2015 prices of primary terbium dropped to around 500 \$/kg lasting until today, and primary europium dropped significantly to 445 \$/kg in 2015 and 30 \$/kg in 2019, thus rendering the recycling process far less competitive than during the crisis (2011-2014). Solvay announced in early 2016 the closure of the plant by the end of 2016. Solvay however still offers yttrium oxides amongst their products.

A number of patents in the literature describe the development of dismantling machines for the automated mechanical treatment of EoL fluorescent lamps. Some current strategies for Y recycling are acid/basic leaching or solvent extraction. In the last years, several European projects were carried out to improve and develop novel strategies for recycling REE. For example, in the SepSELSA project a successful new approach called solid-state chlorination was developed, which could provide various advantages in terms of costs and disposal.

Concerning cerium extraction from scrap, the recycling of cerium containing LEDs has been attempted at pilot scale. The developed process comprises a combination of manual and mechanical processing steps aiming to the removal of non-metallic components and the enrichment of the recycling stream. The results of this research consists a useful tool for the further development of the dismantling and pretreatment processes in case of other electronic wastes. However today, the market price of cerium is very low (6\$/kg for the pure metal, 2\$/kg for the pure oxide), limiting the potential development of a recycling market. In terms of environmental impact, if the recycling strategies rely on the same process used for the primary production, no significant difference is expected. Only a breakthrough in the selected processes could bring an added value for the development of a sustainable secondary production of cerium. (Samouhos et al. 2019: SCRREEN)

#### **21.4.4.7 Other applications**

A minor part of recycled yttrium comes from oxygen sensors contained in end-of-life vehicles (Bio Intelligence Service, 2015).

Ho, Tm, Yb and Lu recovery from scrap has not been attempted even at laboratory scale due to the limited number of end-of-life devices containing these REE and their low concentrations. Specific attention should be given to the collection, classification and dismantling of end-of-life scraps containing Ho, Tm, Yb and Lu as a first recycling-action. (Samouhos et al. 2019: SCRREEN)

### **21.4.5 Processing and separation**

#### **21.4.5.1 World**

There is no data on production of high purity single REE, but it is believed that only China holds industrial scale separation plants for the whole range of REE (this is the current bottleneck).

Lynas Malaysia is one of the largest rare earths separation plants in the world treating the Mt Weld Australia concentrate and produce separated light REO products for sale to customers in locations including Japan, Europe, China and North America. It was designed and built in two phases, with full Phase 2 capacity capable of producing up to 22,000 tonnes per annum of separated REO products. Commissioning of Lynas Malaysia started in late 2012. Currently, the most valuable product produced at the plant is praseodymium/neodymium, NdPr. Lynas produced its first Rare Earths products for customers in February 2013.

USA Rare Earth LLC and Texas Mineral Resources Corp. announced in December 2019 the opening of a REE pilot separation plant in Wheat Ridge, Colorado from the Round Top deposit, El Paso, Texas containing HREE and LREE, lithium, uranium, beryllium, gallium, hafnium and zirconium.

Texas Mineral Resources have also purchased the neodymium iron boron (NdFeB) permanent magnet manufacturing equipment with capacity of 2,000 tonnes per year (17% of the current U.S. market, \$140 million in annual sales at 2019 prices), formerly owned and operated in North Carolina by Hitachi Metals America, Ltd. USA Rare Earth (NdFeB) Permanent Magnet Plant. In late 2011, Hitachi announced the phased construction of a state-of-the-art sintered rare earth magnet manufacturing facility, planning to spend up to \$60 million over four years. However, following settlement of the rare earth trade dispute between China and Japan, Hitachi closed the plant in 2015 after less than two years of operation.

#### 21.4.5.2 EU

The EU has no mining of rare earths, but imports ores and concentrates for refining. Over the last decade, the EU reduced the rare earths processing and refining capacity, such as Solvay operation in La Rochelle. NPM Silmet operation in Estonia is still operational.

At the mining stage, REE are assessed as mixes of REO or low purity single REE ores and concentrates (this roughly corresponds to mining + first stages of processing / separation). CN8 codes used for this stage are: 28461000 "Cerium compounds", 28469010 "Compounds of lanthanum, praseodymium, neodymium or samarium, inorganic or organic" and 28469020 "Compounds of europium, gadolinium, terbium, dysprosium, holmium, erbium, thulium, ytterbium, lutetium or yttrium, inorganic or organic". Eurostat data have been reported as REO content by using the conversion factors (see Table 182).

The use of term "compound" opens for various interpretations, such as to whether it refers to different types of compounds (metals, alloys, oxides, salts), and thus, REE that encompasses all types of compounds, or whether it refers to rare earth metals, as metals of individual elements in form of alloys.

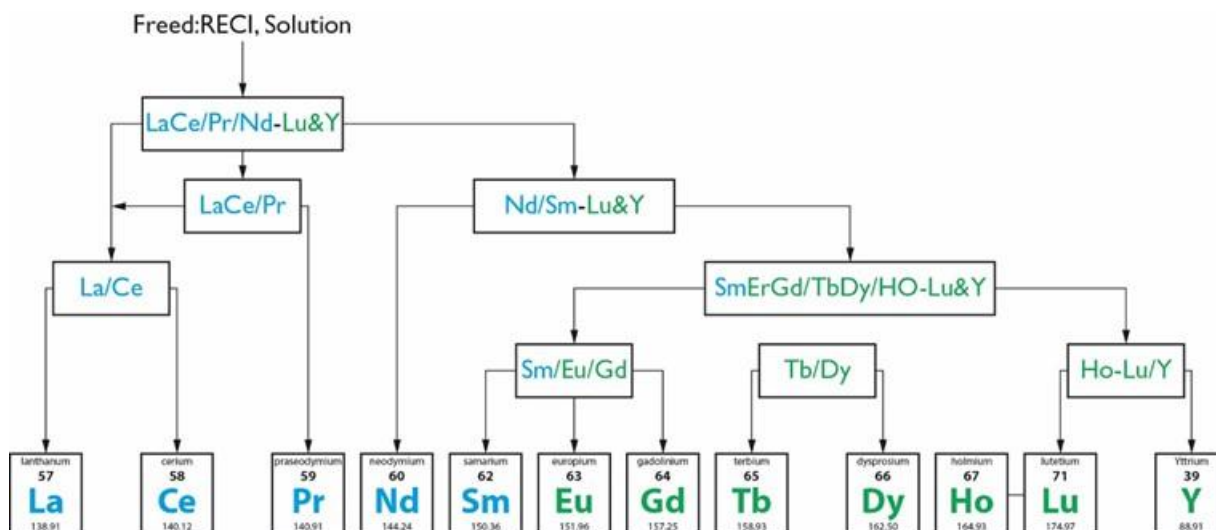
At the refining stage, we consider mixes of high purity single REE (this correspond to advanced separation / refining). The trade codes used for EU trade are CN8: 28053010 "Intermixtures or interalloys of rare-earth metals, scandium and yttrium", 28053020 "Cerium, lanthanum, praseodymium, neodymium and samarium, of a purity by weight of  $\geq 95\%$  (excl. intermixtures and interalloys)", 28053030 "Europium, gadolinium, terbium, dysprosium, holmium, erbium, thulium, ytterbium, lutetium and yttrium, of a purity by weight of  $\geq 95\%$  (excl. intermixtures and interalloys)".

EURARE (2017) reports a global production of 50 kt of REE metals in 2015 mostly centered in China holding industrial scale separation plants (Barakos, 2018). Estonia and United Kingdom produced 500 tonnes in the same period.

REE have a complex supply chain, and products are sold at several stages along the processing and separation sequence. The first step is the processing of the ore to produce mineral concentrates containing mixed rare earth oxides (REOs). Those concentrates can be sold at this stage to downstream processors. However, an increasing proportion of ore is now processed in vertically integrated companies (both in China and the rest of the world) partly due to the difficulty (and cost) to have the specific technology and knowledge to process each individual type of ore (Roskill, 2015).

Further processing lead to REE compounds such as rare earth carbonates, nitrates and chlorides. Those products can be sold to end users such as catalyst manufacturers or are supplied to downstream processors for separation.

The goal of separation is to obtain individual rare earths compounds to a degree of purity of 99.9% (3N) to 99.9999% (6N). The majority of production is in the oxide form but individual rare earth carbonates, chlorides or fluorides can also be produced. This step is technically difficult and costly in comparison to others. It involves various phases; initial separation results in the isolation of lighter elements such as lanthanum and cerium, as well as intermediate products such as mischmetal (La-Ce, La-Ce-Pr or La-Ce-Pr-Nd) and didymium (Pr-Nd). These products are combinations of individual rare earths and can be supplied directly either to magnet alloy producers or in the iron and steel industry. The heavier fractions (Sm-Eu-Gd) are separated in the end. The main method used for separation is solvent extraction (SX), suitable at the industrial scale to produce large tonnages of individual compounds. Ion adsorption is more adequate to extract small quantities of HREE of 6N purity (BRGM, 2015).



**Figure 445: Example of a schematic REE solvent extraction (SX) separation process (Machacek and Kalvig 2017: EURARE adapted from Zhang and Zhao, 2016)**

Further refining is needed for the production of REE metals and alloys. It is also a very costly and complicated step. Most of the time, metallothermic reduction is used for preparation, followed by further reduction where boron, iron or cobalt can be added to form the desired magnets alloys. Pure REE metals (99,999% or more) are the most expensive products and usually purchased for very specific applications.

### 21.4.5.3 Chemical separation methods

*“With respect to physical and chemical properties, the REE have strong similarities; this makes the chemical separation of the individual REE a complicated process. Three types of separation technologies are applied by the industry: (i) the fractional step method; (ii) the ion exchange method (IX), and (iii) the solvent extraction method (SX). The IX and SX methods constitute the processing technologies applied on an industrial scale, close to 100% of which occurs in China (Izatt et al., 2016).*

*To date, conventional chemical separation requires high CAPEX and OPEX, as well as cross-cutting knowledge of mineralogy, geology, chemistry and metallurgy. Up until February 2016, the discussions to minimize CAPEX centered on establishing a tolling station. It was argued that such a centralized facility would provide chemical separation services by processing a mixed REE solution (salts/oxides/chlorides/nitrates) from numerous suppliers of different REE-containing ore into individual REE while complying with the quality requirements of potential buyers. However, two new separation technologies have been introduced in February 2016, both claiming to reduce CAPEX and OPEX significantly: (i) RapidSX™ and (ii) Molecular Recognition Technology (MRT). The technology applied is briefly described below:*

*Fractional step method: Builds on the different solubility of the REE compounds in the solvent. This fractional step method has led to the production of most compounds of REE, which was a long process due to its complicated nature, specifically, the hundred fold repetition of the extraction for each element, which reduces the feasibility of this method at large-scale.*

*Ion exchange (IX) method: originally developed to remove the REE from U and Th, and later it was used to separate the REE. A single operation enabled the separation of multiple REE into high purity metals. The disadvantage was the lengthiness and need for discontinuity of the*

process, which led to the replacement of this method by solvent extraction. Nonetheless, ion exchange is still used for the production of high purity products.

*Solvent extraction (SX) method: centers on a leach solution of REE which is forcibly stirred with an immiscible organic solvent which extracts the preferred elements and separation occurs after the disengagement of both non-miscible liquids. A conventional SX-plant has a multitude of mixer-settlers (also referred to as batteries) which require high capital investment.*

*RapidSX™: Innovation Metals Corp (IMC) released, in February 2016, a more efficient SX-technology, called RapidSX™. This had been developed with the aim of revolutionizing chemical processing, reducing both CAPEX and OPEX, and reaching product purities greater than 99%. The process has been tested on feedstock from Mineração Serra Verde ("MSV") deposit in Goiás State, Brazil, and a patent application is pending.*

*Molecular Recognition Technology (MRT): Ucore Rare Metals (Ucore) and IBC Advanced stage Technologies Inc., released in February 2016 a white paper on a highly metal-selective green chemistry procedure, not based on the use of organic solvents; it has been applied for the separation of individual REE at >99% purity levels from pregnant leach solutions from the Bokan-Dotson Ridge deposit, Alaska (Press Release, 2015, March 2; Press Release, 2015, April 28) (Izatt et al., 2016) argue that significant savings in CAPEX and OPEX can be achieved by use of MRT.*

*Generally, separation of the LREE, La-Ce-Pr-Nd, is relatively easy as opposed to HREE which pose more separation challenges as more specialized process knowledge is required to successfully separate them (Leveque, 2014). Conventional separation technology requires several, sequential process steps to obtain an individual REE product, e.g. a REO such as neodymium oxide ( $Nd_2O_3$ ) or lanthanum oxide ( $La_2O_3$ ) that still contain proportions of other REE, e.g. 0.1% Ce and 0.01% Y. For instance, with solvent extraction methods, between 30 and 100 stages are needed for each separation cut between adjacent REE, to reach purity for individual REE of 99% up to 99,999% (5Ns) (Leveque, 2014).*

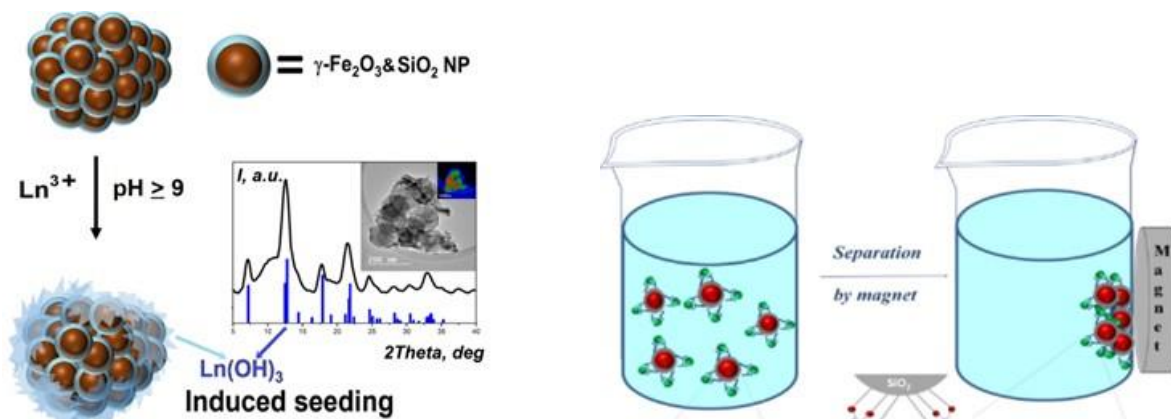
*Despite, or perhaps due to, non-existent patent-protection for the process, it remains challenging to successfully separate HREE. High demand is on tight and precise process control which involves both maintaining and adjusting operating conditions, and using solvents adequately under these conditions (Leveque, 2014). Solely one European player and one Japanese player were able to separate the HREE besides some of the Chinese companies in early 2014 (Interviews, 2013).*

*The proposed Kvanefjeld project draws on SX to remove La and Ce from the RE-Chloride to produce  $La_2O_3$ ,  $Ce_2O_3$ , mixed La-Ce-oxide, all at 99% purity, and a mixed critical REO (Pr to Y) (GMEL, 2015).*

*A new separation technology has been developed by the EURARE project, which has the potential to be an alternative to the MRT technology. The EURARE-technology involves appropriate ligands being grafted onto magnetic silica nanoparticles, which are introduced to the REE solutions. The produced adsorbents demonstrated rather quick adsorption kinetics, achieving at least 80% of maximal capacity within some few minutes. Considerable selectivity is observed, favoring retention of HREE (Dy in comparison with Nd and La) with distribution coefficients achieving values over 80:1. The magnetic nature of the nanoparticle allows for simple and robust solid/liquid separation with use of magnets. The principles of the EURARE technology are shown*



in Figure 446. Application of this technology in processing REE from both ore leachate and from dissolved components in recycling processes should offer efficient uptake and controlled release under precisely defined pH conditions.” (Machacek and Kalvig 2017: EURARE)



**Figure 446: Principles in the magnetic nanoparticle separation technology (Machacek and Kalvig 2017: EURARE)**

“Note: The figure to the left shows an approach for more specific extraction (separation of the other metals than REE), and the one to the right shows molecular recognition with a complexonate type ligand (while MRT is using crown-ether ligands). Complexonate ligands are derived from amino acids and are environmentally friendly in contrast to potentially hazardous crown-ethers.

Another extraction and separation technology developed by the EURARE project aims to both decrease the CAPEX and OPEX, and separate the HREE from aqueous chloride feed solutions using a neutral extractant (Larsson and Binnemans, 2015). Until now, neutral extractants could not efficiently extract REE from chloride solutions. The EURARE-technology involves an ionic liquid that effectively transports the REE from the chloride aqueous phase into the water-immiscible ionic liquid. This ionic liquid extraction technology will reduce CAPEX for the separation plant (less equipment and fewer extraction stages), and OPEX due to the exclusion of acidic extractants, easier waste water treatment. Moreover, the replacement of organic solvents by non-fluorinated water-saturated ionic liquids is an improvement on current technology, regarding health, safety and environmental standards.

A REE-separation plant ‘REEttec’ was established in Norway with a new and ‘game changing’ process for the manufacture of high purity REE (REEttec AS, 2016), though no further details have been released. REEttec is a sister company of Fen Minerals, one of the EURARE partners, and has been producing and selling small volumes of REE since 2015. A large unit with a capacity of several hundreds of tons for separation is planned to be installed in 2017, and it is anticipated for this unit to be operational from 2018 (personal communication with B. Bergfald, Dec. 2016).” (Machacek and Kalvig 2017: EURARE)

## 21.5 Other considerations

---

### 21.5.1 Standardisation – Technical committee ISO/TC 298 on Rare earths

The International Organization for Standardization (ISO) has formed a technical committee (ISO/TC 298<sup>238</sup>) in September 2015, following the proposal from China, to explore the possibility of international standardization of rare earth products. The Standardization Administration of China (SAC) has been appointed as the secretariat. Currently, nine countries, including Denmark, are participating members of the technical committee and there are 24 observing members, including 10 from EU. 11 ISO standards are under development in the fields of rare earth mining, concentration, extraction, separation and conversion to useful rare earth compounds/materials (including oxides, salts, metals, master alloys, etc.).

<b>Participating Members (9)</b>	Australia (SA)	<u>Denmark (DS)</u>	Korea, Republic of (KATS)
	Canada (SCC)	India (BIS)	Russian Federation (GOST R)
	China (SAC)	Japan (JISC)	United States (ANSI)
<b>Observing Members (24)</b>	Argentina (IRAM)	<u>Germany (DIN)</u>	<u>Poland (PKN)</u>
	Armenia (SARM)	Iran, Islamic Republic of (ISIRI)	<u>Portugal (IPQ)</u>
	Brazil (ABNT)	Israel (SII)	Saudi Arabia (SASO)
	Cuba (NC)	<u>Italy (UNI)</u>	South Africa (SABS)
	<u>Czech Republic (UNMZ)</u>	Malaysia (DSM)	<u>Spain (UNE)</u>
	Egypt (EOS)	Mexico (DGN)	<u>Sweden (SIS)</u>
	<u>Finland (SFS)</u>	<u>Netherlands (NEN)</u>	Switzerland (SNV)
	<u>France (AFNOR)</u>	Pakistan (PSQCA)	Viet Nam (STAMEQ)

### 21.5.2 Environmental and health and safety issues

#### 21.5.2.1 Relevant EU regulations for the mining of REE in Europe

Three different EU regulations apply to mining and milling waste and other aspects of REE mining and processing (ERECON 2015).

**EIA directive 2014/52/EU**<sup>239</sup> concerns regulatory processes in cases where environmental effects are not negligible. It requires member states to set up licensing procedures that explore projects' potential environmental impacts, evaluate those impacts, and describe ways to reduce

---

<sup>238</sup> <https://www.iso.org/committee/5902483.html>

<sup>239</sup> Directive 2014/52/EU of the European Parliament and of the Council of 16 April 2014 amending Directive 2011/92/EU on the assessment of the effects of certain public and private projects on the environment. – Official Journal of the European Union, L 124/1, 25.4.2014

those impacts to certain levels. Given the considerable environmental impacts of REE mining, this directive is applicable to REE mining projects. The process laid out in the directive, if properly followed, guarantees that those impacts are reduced to acceptable levels.

**Directive 2006/21/EC**<sup>240</sup> regulates mining wastes, which requires Member States to “prohibit the abandonment, dumping or uncontrolled depositing of extractive waste obligate mining operators” to comply with high environmental standards and “to ensure that extractive waste is managed without endangering human health and without using processes or methods which could harm the environment” (Article 4). The Directive also requires a “waste management plan for the minimization, treatment, recovery and disposal of extractive waste” (Article 5), with particular attention to water pollution issues (Article 13). The directive is backed by a 557-page document that describe the state-of-the-art and best-available technologies in Europe.<sup>241</sup> This describes in detail the latest ways to manage the life-cycle of mines, including how to manage acid run-off, seepage, emissions to water, noise, dam design and construction, raising of dams, dam operation, closure and aftercare.

**Directive 2013/59/Euratom**<sup>242</sup> regulates radiation protection issues in the EU member states. It contains provisions for the re-use and disposal of wastes from naturally occurring radioactive materials (NORMs) and sets protection limits for exposures to limit health damages. It is applicable to REE mining wastes, as these are considered a typical NORM waste in the directive. The directive sets exposure limits, but, unlike the mining waste directive, it does not include guidance on how to achieve those goals and has no specific requirements for large-mass wastes such as tailings from uranium plants and REE production facilities.

REE mill tailings – including both radioactive as well as non-radioactive hazardous constituents – are covered and well addressed by directives that limit environmental consequences to the extent possible and practical. Additional regulations specific to rare earths do not currently appear to be necessary.

However, two factors could complicate practical regulatory processes in Europe: (1) The separate regulation of radioactive and toxic constituents of mining and milling wastes in the EU regulation framework and (2) the lack of additional guidance below the level of the directive on radiation protection. Such factors could lead to unnecessarily long discussions between licensees and the radiation protection regulators, as the permitting of REE mining and processing facilities could become single-case decisions. More specific requirements for the long-term enclosure of large-volume NORM wastes in above-ground disposal facilities for mill tailings could increase transparency and help to speed up the regulatory process. (ERECON 2015)

---

<sup>240</sup> Directive 2006/21/EC of the European Parliament and of the Council of 15 March 2006 on the management of waste from extractive industries and amending Directive 2004/35/EC. - Official Journal of the European Union, L 102/15, 11.4.2006

<sup>241</sup> European Commission: Best Available Techniques document for the Management of Waste from the Extractive Industries, in accordance with Directive 2006/21/EC, abbreviated as MWEI BREF. Reviewed in 2018.

<sup>242</sup> Directive 2013/59/Euratom - protection against ionising radiation of 5 December 2013 laying down basic safety standards for protection against the dangers arising from exposure to ionising radiation, and repealing Directives 89/618/Euratom, 90/641/Euratom, 96/29/Euratom, 97/43/Euratom and 2003/122/Euratom

### 21.5.2.2 Toxicity and radioactivity

REE extraction and processing faces environmental and health and safety challenges. At present, however, information regarding the environmental aspects of REE mining is limited. Toxicological data about the effects of REE on aquatic, animal, or human health are also limited (USGS 2017b).

REE-minerals are in many cases associated with uranium (U) and thorium (Th), either incorporated into the lattice of the REE-minerals or in associated minerals within the ore mineral assemblage. This is particularly the case for the alkaline igneous and carbonatite-associated REE mineralization, and also typically for placers. During the precipitation and selective dissolution, U and Th will exit the solvent extraction circuit and become radioactive waste. Some of the Th and U are removed during all the purification steps (precipitation, selective dissolution), but due to the strong extraction of  $Zr^{4+}$ ,  $Th^{4+}$ ,  $UO^{22+}$  and  $Fe^{3+}$  these metals will be extracted together with the HREE fraction (Email communication with respondent of Mintek, 2013). The radioactive elements can remain a part of the REE concentrate. Once they are liberated, they act as individual elements. For instance, the decay daughter of U-235, actinium isotope Ac-227 behaves like lanthanum and remains with the REE. U and Th are used as indicators for the presence of other radiogenic daughter products. (Machacek and Kalvig 2017: EURARE)

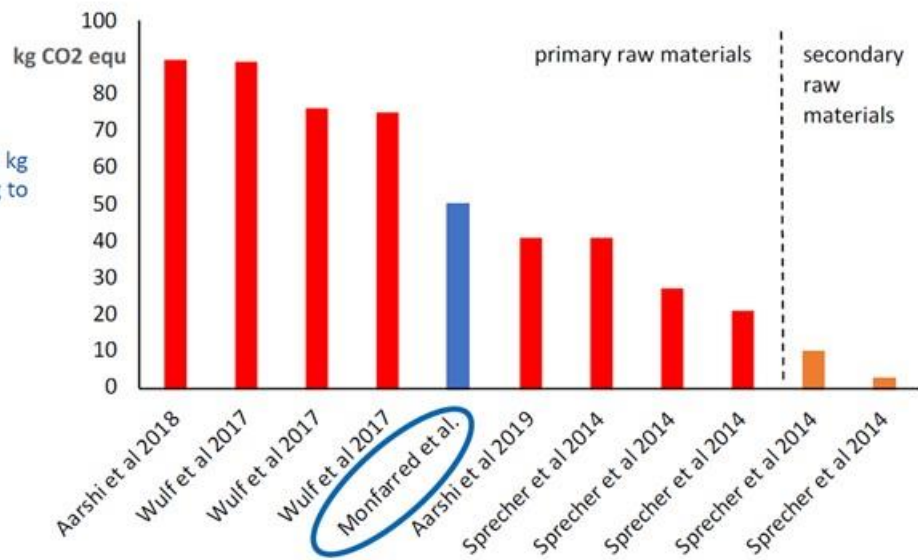
Radioactivity is one of the issues that has to be addressed with care as it is a matter of real concern to local communities. Rare earth minerals are frequently collocated with naturally occurring radioactive material, monazite has the highest thorium content, while bastnäsite contains relatively low concentrations of both thorium and uranium. The thorium content in mineral concentrates varies from less than 0.1 to about 10%, while the uranium content varies from very low values to 1% (IAEA, 2011).

Depending on minerals and process used, their extraction, separation and refining may result in waste containing higher levels of radioactive material which can have serious health and environmental impacts (Koltun & Tharumarajah, 2014) (IEA, 2011). Rim, Koo, and Park (2013) state that the whole process poses a great risk to miners and residents of mining towns who inhale higher amounts of radioactive dust. However, currently available methodologies in life cycle assessment are insufficient to account for the impact of naturally occurring radioactive materials on both humans and ecosystems (Frischknect, 2000) (Garnier-Laplace et al., 2009). A newly devised NORM impact category addresses this issue (Goronovski et al., 2018; Joyce et al., 2017). However, it is been shown that the materials found in REE are not more radioactive than the radioactivity humans are exposed to daily.

Toxicity is another issue for the REE which has been exposed via life cycle assessment. However, the models for toxicity of metals are not robust enough to be taken at face value. There is a big question of interpretation for these categories within life cycle assessment (Santero and Hendry, 2016). All REE can cause organ damage if inhaled or ingested in large quantities; some must be handled with extreme care to avoid poisoning or combustion (Geological Survey of Finland, 2014) (Higgins, 2015).

Life Cycle Impact data for REO mining, extraction, and processing are very much incomplete.

Global Warming Potential of 1 kg NdFeB (kg CO2 equ) according to various LCA reports.



**Figure 447: LCA-studies (EIT RM)**

### 21.5.2.3 Enabling climate targets

Over the past two to three years, an ever-growing list of countries have announced impending bans on sales of new gasoline- and diesel-powered vehicles by as early as 2025. And similarly, an ever-growing list of cities have announced impending bans that will prohibit use of gasoline- and diesel- (or just diesel-) powered vehicles within city limits by as early as 2024.

The nine countries and one U.S. state in the list on the left collectively have potential to fuel electric vehicles sales to upwards of 10 million per annum by 2030 and 20 million per annum by 2040 and in doing so, would collectively make a major contribution towards meeting the Paris Climate Commitment targets. Such a massive deployment of electric vehicles could create demand for approximately 25,000 tonnes of NdFeB annually by 2025 and 60,000 tonnes by 2030. (Adamas Intelligence, 2019)

Country	Ban Commences	Passenger Vehicle Market Size (2018)
Norway	2025	0.2 million
Germany	2030	3.8 million
Ireland	2030	0.2 million
Israel	2030	0.3 million
India	2030	4.0 million
Netherlands	2030	0.4 million
U.K.	2040	2.9 million
France	2040	2.6 million
Taiwan	2040	0.3 million
U.S. (California)	2040	2.0 million

City	Ban Commences	Population (2018)
Rome	2024	2.9 million
Paris	2025	2.1 million
Madrid	2025	3.2 million
Mexico City	2025	8.9 million
London	2030	8.1 million
Los Angeles	2030	4.0 million
Hainan	2030	8.7 million
Seattle	2030	0.7 million
Vancouver	2030	0.7 million
Amsterdam	2030	0.8 million

**Figure 448: list of countries and cities have announced impending bans on sales or use of gasoline- and diesel-powered vehicles (Marklines, The World Bank, United Nations, Adamas Intelligence research)**

### 21.5.3 Socio-economic issues

There are few recent studies conducted regarding the social issues pertaining to the extraction and production of REE-containing products. Werker et al. (2019) conducts a social LCA on three different REE mine and magnet production sites. The impact categories evaluated are numerous ranging from issues of social responsibility, fair competition and corruption. Overall, out of the three sites evaluated, the US value chain indicates the lowest level of social risk along the supply chain (Werker et al., 2019). Across all three cases, the mineral, fossil fuel and chemical sectors are shown to be problematic in terms of impact to society.

Recently, Bailey (2019) developed a methodology for performing life cycle assessment for the entire life cycle and cost of REE inside magnets and motors, using economical and environmental models for cost-efficient and environmentally-friendly direct and indirect recycling routes.

Another study evaluates the importance of the REE and other CRMs supply risk using the World Governance Index (WGI) (Mancini et al., 2018). The purpose of the supply risk based characterization factors (CFs) provided by Mancini et al. (2018) is to warn practitioners of the use of CRMs, rather than to measure an environmental impact.

Mancini et al. (2018) developed these CFs by dividing the supply risk by the world governance index, which is a modified Herman Hirshfindaal indicator (HHI) on concentration of supply. This data provided in European Commission (2017) and appropriated them as midpoint CFs. The list of CFs are included in the methodology are as follows:

$SR_{WGI}$  is supply risk based on WGI

- $SR_{WGI}$  = supply risk due to low governance

- $SR_{WGI}^6$  = supply risk due to low governance exponential
- $SR_{WGI}/Production$  = supply risk related to global mine production
- $SR_{WGI}/Reserves$  = supply risk related to geological reserve data

The  $SR_{WGI}$  dataset denotes a risk of supply disruptions due to supply concentration and political instability of the producing country. This supply risk aspect is characterized using  $SR_{WGI}$  data provided in the European Commission study on CRM and appropriates each  $SR_{WGI}$  value for each material or resource as midpoint CFs (European Commission, 2017). The  $SR_{WGI}$  has low variability; therefore, the difference between materials or resources in terms of security is not evident when these values are applied as linear weighting factors, so a subjective exponent of 6 was added to this assessment to be able to better view the supply security (Mancini et al., 2018). The  $SR_{WGI}/Production$  divides the supply risk by the size of the market, that is, the global mine production in a given year, in order to better capture niche materials having small markets (Mancini et al., 2018). Despite the imprudent use of reserves data as an indicator for production potential, the  $SR_{WGI}/Reserves$  method divides the supply risk by geological reserve data to be able to include, "an element related to resource availability" (Mancini et al., 2018). Thus, when applying an element of criticality and resource efficiency to an environmental assessment, then the supply risk for REE is important which also reveals the benefits of recycling.

## 21.5.4R&D

### ERECON

ERECON was an EU funded action to create a network of REE stakeholders finished in 2015. After the end of ERECON, a large number of stakeholder platforms, industry activities and research projects have emerged as a response to increasing concerns over supply security of REE.

The EU financed REE related R&D projects for over a decade.

The project targeted primary and secondary production of rare earths and magnets, substitution of REE and expert networks. Below in Table 178 some of the relevant projects are listed.

However, to our knowledge there is still no mainstream solution today for recovering REE applied on the EU primary resources and end-of life products.

**Table 178: Overview of projects from the 7th Framework Programme, Horizon 2020, ERA-MIN, ERA-MIN 2 as well as EIT Raw Materials that are concerned with supply security of REE (European Commission 2018).**

<i>project</i>	<i>budget (million €)</i>	<i>metals secured</i>	<i>information and transparency</i>	<i>secondary supply</i>	<i>industry and innovation</i>
EURARE	13.8	REE	x		
MIDAS	12.3	Co, Mn, REE	x		
REE4EU	9.1	REE		x	
REEcover	7.9	REE (Y, Tb, Nd, Dy)		x	
SCALE	7.7	REE (Sc)		x	
FAME	7.5	unspecified	x		
NOVAMAG	7.1	REE,			x
ADIR	6.6	Ta, REE, Ge, Co, Pd, Ga, W		x	
REProMag	5.7	REE			x

<i>project</i>	<i>budget (million €)</i>	<i>metals secured</i>	<i>information and transparency</i>	<i>secondary supply</i>	<i>industry and innovation</i>
HiTech AlkCarb	5.4	REE (Sc), Nb, Hf, Ta, Zr	x		
PARTIAL-PGMs	5.0	PGM (Pt, Pd, Rh), REE			x
AMPHIBIAN	4.9	REE			x
COLABATS	4.6	Co, REE, Ni, Li		x	
RECYVAL-NANO	4.4	In, REE (Y, Nd)		x	
EREAN	3.9	REE		x	
DEMETER	3.8	REE (Nd, Sm)		x	
HYDROWEEE DEMO	3.8	REE : Ce,Eu, La, Tb, Y ; In, Li, Co, Zn, Cu, Au, Ag, Ni, Pb, Sn, PGM (Pt, Pd)		x	
REDMUD	3.7	Fe, Al, Ti, REE (Sc)		x	
REMAGHIC	3.7	REE		x	
ProSUM	3.7	secondary CRMs and other materials		x	
MAG-DRIVE	3.6	REE (Nd, Dy)			x
ARMEVA	3.6	REE			x
SCREEN	3.0	all CRMs	x	x	x
VENUS	2.9	REE			x
SMART GROUND	2.5	Unspecified		x	
SOLCRIMET	2.5	REE, Ta, Nb, Co, In, Ga, Ge, Sb		x	
ENVIREE	2.5	REE	x	x	
NOVACAM	2.4	PGMs (Pt, Pd, Rh), REE			x
REE-CYCLE	2.3	REE		x	
MinFuture	1.2	unspecified	x	x	
RAREASH	1.1	REE		x	
AMDREY	1.0	REE (Y)	x	x	
HYTECHCYCLING	0.5	unspecified		x	
CAPTURE	0.3	REE, Cu, Zn, Ni	x		
REMSIL	0.2	REE		x	
QUMEC	0.2	unspecified		x	
REE Value Chain	0.2	REE	x	x	
MINEPEP	0.2	REE (La, Y)		x	
BATRe ARES	n.a.	REE		x	
FREECATS	n.a.	PGM, REE, Cr			x
inSPECTor	n.a.	REE, others	x		
INSPIRE	n.a.	unspecified	x	x	
PCRec	n.a.	unspecified		x	
SPARK	n.a.	REE		x	x
STRADE	1.9	unspecified	x	X	
ReCREW	n.a.	unspecified	X	x	
MINATURA 2020	2.0	unspecified	x	X	



<i>project</i>	<i>budget (million €)</i>	<i>metals secured</i>	<i>information and transparency</i>	<i>secondary supply</i>	<i>industry and innovation</i>
INTRAW	2.1	unspecified	X	X	x
REMANANCE	4.9	REE	X	x	X
REMinE	n.a.	unspecified	X		x
CERA	n.a.	unspecified	x		X
EMFIS	1.0	unspecified	x		X
IRTC	n.a.	unspecified	x		X
SIMS	16.1	unspecified			x
SMART GROUND	2.4	unspecified			x

## 21.6 Comparison with previous EU assessments

A revised methodology was introduced in the 2017 assessment of critical raw materials in Europe and both the calculations of economic importance and supply risk are different compared to the results of the previous assessments. Therefore, the changes observed are largely due to the revised methodology and not due to significant market changes.

The individual assessment results of each of the 15 REE indicate that each one should be considered critical, with the exception of lanthanum.

The main driver for the Supply Risk result for the overall REEs group is explained by important EU reliance on Chinese production, which are characterised by the quotas / export taxes from China enacted during the 2012 – 2016 period. Generally speaking, there is no significant REE transformation and manufacturing activity in the EU; a large proportion of EU consumption / imports of REE comes from finished products to the EU (e.g. magnets, alloys, hard drives, laptops, electric or hybrid vehicles, etc.). Further, in most of their applications, REE are not substitutable without losses of performance. However, for economic reasons, many R&D strategies have focused on reducing the amount of REEs used in their different applications.

The results of the 2020 assessment and the previous assessments are shown in Table 179.

**Table 179: Economic importance and supply risk results for REE in the assessments of 2011, 2014 (European Commission, 2011; European Commission, 2014) and 2017.**

Assessment year	2011		2014		2017		2020	
Indicator	EI	SR	EI	SR	EI	SR	EI	SR
LREEs	5.78	4.86	5.37	4.67	3.6	4.9	4.3	6.0
HREEs			5.21	3.13	3.7	4.8	3.9	5.6

## 21.7 Data sources

### 21.7.1 Data sources used in the factsheet

ACREI (2019) China's efforts toward a sustainable REE supply chain; Chen Z., Association of China Rare Earth Industry, The Chinese Society of Rare Earths; Conference on Rare earths & 1st General Assembly of REIA, 25-27 June 2019, Brussels

- Adamas Intelligence (2014) Rare Earth Market Outlook: Supply, Demand, and Pricing from 2014 – 2020, edited by R. Castelloux. Published on October 1, 2014
- Adamas Intelligence (2019) ELECTRIC GROWTH | EVs, Motors and Motor Materials
- Adamas Intelligence (2019b) RARE EARTH ELEMENTS | Market Issues and Outlook
- Alavi, S. E., Soltanian, M. R., Amiri, I. S., Khalily, M., Supa'at, A. S., & Ahmad, H. (2016). Towards 5G: A Photonic Based Millimeter Wave Signal Generation for Applying in 5G Access Fronthaul. *Scientific reports*, 6, 19891. <https://doi.org/10.1038/srep19891>
- Allied Market Research (2016) Lithium-ion Battery Market by Material Type (Cathode, Anode, Electrolytic solution, Foils, Binders, Separators) and Industry Vertical (Smartphones, UPS, Cars, Aircraft, Busses, Trucks, Mining equipment, Smart grids, Games, Gardening tools) – Global Opportunity Analysis and Industry Forecast, 2015-2022.
- ARAFURA (2016) Rare Earth Supply & Demand [online] Available at: <http://www.arultd.com/rare-earths/supply-demand.html>
- Barakos (2018) A forward look into the U.S. Rare Earths Industry; How potential mines can connect to the global REE market. Barakos, George; Mischo, Helmut; Gutzmer, J. February 2018. Conference: SME 2018 Annual Meeting & Expo at: Minneapolis, MN.
- Bailey, G., 2019. PhD thesis. Life Cycle Assessment of new recycling and reuse routes for Rare Earth Element machines in hybrid/electric vehicles. KU Leuven.
- Binnemans (2013) Recycling of rare earths: a critical review. *J. Clean. Prod.* 51, 1e22. , Binnemans, K., et al. (2013)
- Binnemans (2013a) Rare earth economics : the balance problem. *JOM* 65 (7), pp. 846-848, <http://doi.org/10.1007/s11837-013-0639-7>
- Binnemans and Jones (2015) Rare Earths recycling and the balance problem. Presentation at the EREAN Summer School, KU Leuven, August, 2014.
- Binnemans, K. (2015) Rare earths : essential elements for the transition to a low-carbon economy. Bauxite Residue Valorisation and Best Practises, Leuven (Belgium), 5-7/10/2015
- Binnemans, Koen & Jones, Peter & Müller, Torsten & Yurramendi, Lourdes. (2018) Rare Earths and the Balance Problem: How to Deal with Changing Markets?. *Journal of Sustainable Metallurgy*. 4. [10.1007/s40831-018-0162-8](https://doi.org/10.1007/s40831-018-0162-8).
- Bio Intelligence Service (2015) Study on Data for a Raw Material System Analysis: Roadmap and Test of the Fully Operational MSA for Raw Materials – Final Report. Prepared for the European Commission, DG GROW
- BRGM (2015) Panorama 2014 du marché des Terres Rares. Rapport public BRGM/RP-64330-FR.
- Castor and Hendrik (2006) 'Rare earth elements - S.B. Castor, J.B. Hendrik - J.E. Kogel, N.C. Trivedi, J.M. Barker, S.T. Krukowski (Eds.), *Industrial Minerals and Rocks: commodities, Markets, and Uses*, vol. 7, Society for Mining Mineralogy, United States (2006), pp. 769-792'.
- CEC (2015) Environmentally Sound management of End of life Batteries from Electric-Drive Vehicles in North America. Montreal, Canada: Commission for Environmental Cooperation. 103 pp.
- Chi, R., Tian, T. (2008) *Weathered Crust Elution-deposited Rare Earth Ores*. Nova Science Publishers, Inc., New York.

CRS (2013) Rare Earth Elements – the global supply chain.

Cui, J., Kramer, M., Zhou, L., Liu, F., Gabay, A., Hadjipanayis, G., Balasubramanian, B., Sellmyer, D. (2018) Current progress and future challenges in rare-earth-free permanent magnets, *Acta Materialia*. Volume 158, 2018, Pages 118-137, ISSN 1359-6454. <https://doi.org/10.1016/j.actamat.2018.07.049>.

Deady (2014) Rare Earth Elements in Karst-Bauxites : A novel untapped European resource ? ERES 2014 ; European Rare Earth Resources Conference, Milos 04-07 Sept 2014. Deady, E.A., Mouchos, E., Goodenough, K., Williamson, B.J., Wall, F. (2014)

Deady (2016) Leaching of rare earth elements from eudialyte concentrate by suppressing silica gel formation. *Minerals Engineering* (Article in press, January 2017). Deady, E.A., Mouchos, E., Goodenough, K., Williamson, B.J., Wall, F. (2016)

Delamarche M. (2016) Solvay renonce au recyclage des terres rares. *L'Usine Nouvelle*, 26/01/2016, [online] Available at : [www.usinenouvelle.com/article/solvay-renonce-au-recyclage-des-terres-rares.N375935](http://www.usinenouvelle.com/article/solvay-renonce-au-recyclage-des-terres-rares.N375935)

DERA (2017) Deutsche Rohstoffagentur Preismonitor [online] Available at: [www.bgr.bund.de/DE/Themen/Min\\_rohstoffe/Produkte/Preisliste](http://www.bgr.bund.de/DE/Themen/Min_rohstoffe/Produkte/Preisliste)

DERA (2018) Chinas Rohstoffpolitik Für Seltsene Erden. *Commodity Top News* 57. Yun Schüler-Zhou. German Mineral Resources Agency (DERA) at the Federal Institute for Geosciences and Natural Resources (BGR)

DERA (2019) German Mineral Resources Agency (DERA) at the Federal Institute for Geosciences and Natural Resources (BGR). *Pricelist of raw materials/*. Available at: [www.bgr.bund.de/DE/Themen/Min\\_rohstoffe/Produkte/Preisliste](http://www.bgr.bund.de/DE/Themen/Min_rohstoffe/Produkte/Preisliste) (Accessed: 31 January 2020).

ERECON (2014) Strengthening the European rare earths supply chain-Challenges and policy options. *European Rare Earths Competency Network, final conference draft*, pp.104. [online] Available at: [https://ec.europa.eu/growth/sectors/raw-materials/specific-interest/erecon\\_en](https://ec.europa.eu/growth/sectors/raw-materials/specific-interest/erecon_en)

European Commission (2011) Critical raw materials for the EU. [online] Available at: [https://ec.europa.eu/growth/sectors/raw-materials/specific-interest/critical\\_en](https://ec.europa.eu/growth/sectors/raw-materials/specific-interest/critical_en)

European Commission (2014) Report on Critical Raw Materials for the EU. [online] Available at: [https://ec.europa.eu/growth/sectors/raw-materials/specific-interest/critical\\_en](https://ec.europa.eu/growth/sectors/raw-materials/specific-interest/critical_en)

European Commission (2016) DG Trade. *Agreements* [online] Available at: <http://ec.europa.eu/trade/policy/countries-and-regions/agreements/>

European Commission (2017) Report on Critical Raw Materials for the EU. [online] Available at: [https://ec.europa.eu/growth/sectors/raw-materials/specific-interest/critical\\_en](https://ec.europa.eu/growth/sectors/raw-materials/specific-interest/critical_en)

European Commission (2018) and A.N. Løvik, C. Hagelüken, P. Wäger, Improving supply security of critical metals: Current developments and research in the EU, *Sustainable Materials and Technologies*, 15 (2018) 9-18.

Eurostat (2019a) International Trade Easy Comext Database [online] Available at: <http://epp.eurostat.ec.europa.eu/newxtweb/>

Eurostat (2019b) Statistics on the production of manufactured goods (PRODCOM NACE Rev.2). [online] Available at: <http://ec.europa.eu/eurostat/data/database>

- Eurostat (2019c) Annual detailed enterprise statistics for industry (NACE Rev. 2, B-E). [online] Available at: [http://ec.europa.eu/eurostat/en/web/products-datasets/-/SBS\\_NA\\_IND\\_R2](http://ec.europa.eu/eurostat/en/web/products-datasets/-/SBS_NA_IND_R2)
- Gambogi J.(2016) Mineral Commodity Summaries. Rare Earths, U.S. Geological Survey. pp.2
- Gehm R. (2013) "Hitachi Metals Reduces Rare-earth Dysprosium in Electric-motor Magnets", SAE International, 2013
- Global Market Insights Inc. (2017) Permanent Magnet Market Size, Industry Share Report – 2024. Report ID: GMI1113. Available at: <https://www.gminsights.com/industry-analysis/permanent-magnet-market>
- Goodenough, K.M., Schilling, J., Jonsson, E., Kalvig, P., Charles, N., Tuduri, J., Deady, E.A., sadeghi, M., Schiellerup, H., Mueller, A., Bertrand, G. Arvanitidis, N., Eliopoulos, D.G., Shaw, R.A., Thrane, K., Keulen, N. (2016) Europe's rare earth element resourcepotential: An overview of REE metallogenetic provinces and their geodynamic setting. *Ore Geology Reviews* 72, 838-856.
- Goodenough, Kathryn & Wall, F. & Merriman, David. (2017) The Rare Earth Elements: Demand, Global Resources, and Challenges for Resourcing Future Generations. *Natural Resources Research*. 10.1007/s11053-017-9336-5.
- Grand View Research, Inc. (2014) Permanent Magnets Industry Trends and Market Segment Forecasts to 2020. Retrieved on February 10, 2017 from <http://ireport.cnn.com/docs/DOC-1112999>
- Guyonnet D., Planchon M., Rollat A., Escalon V., Tuduri J., Charles N., Vaxelaire S., Dubois D., Fargier H. (2015) Material flow analysis applied to rare earth elements in Europe, *Journal of Cleaner Production*, Volume 107, 16 November 2015, Pages 215-228
- Haxel et al. (2002) 'Rare Earth Elements—Critical Resources for High Technology - Gordon B. Haxel, James B. Hedrick, and Greta J. Orris. Available at: <https://pubs.usgs.gov/fs/2002/fs087-02/>.
- Henriques, C. (2012). Catalysis by Zeolites. EUCHEME 11/08/2012. Available at: <http://d7.unicam.it/eucheme/sites/d7.unicam.it/eucheme/files/files/doc/Prof.%20Carlos%20M.%20F.%20B.%20Henriques%201.pdf>
- Higgins I. (2016) Less Common Metals, communication during the CRM workshop held in Brussels on 28/10/2016.
- Hoyle R. (2016) Rare earths miner Lynas plans debt overhaul. *The Australian, Mining & Energy*, 26/10/2016 [online]
- IAEA (2011) International Atomic Energy Agency, Radiation Protection and NORM Residue Management in the Production of Rare Earths from Thorium Containing Minerals, Safety Reports Series No. 68, IAEA, Vienna (2011)
- Inframat Advanced Materials (2017). Available at: <http://www.advancedmaterials.us/>
- Kalvig, P. and Machacek, E. (2017) Examining the rare-earth elements (REE) supply–demand balance for future global wind power scenarios [online] Available at: [https://eng.geus.dk/media/19206/nr41\\_p87-90.pdf](https://eng.geus.dk/media/19206/nr41_p87-90.pdf)
- Kiggins, R. (2015). *The Political Economy of Rare Earth Elements: Rising Powers and Technological Change*. Palgrave Macmillan UK, XIV, 228.

Kingsnorth (2012) 'Rare earths supply security: Dream or possibility. In: Proceedings of the Oral Presentation at the 4th Freiberg Innovations Symposium, Freiberg, Germany. Kingsnorth, D.J., 2012.'

Kingsnorth, D. (2016). Curtin University publication on the rare earth industry in 2016.

Kingsnorth D. (2018) The Rare Earth Market in 2018, Driven by e-Mobility, IMCOA and Curtin University, Perth

Kozawa S. (2010). "Trends and Problems in Research of Permanent Magnets for Motors", Science and Technology Trends 2010

Lin, S.L., Huang, K.L., Wang, I-C., Chou, I-C., Kuo, Y.M., Hung, C.H., Lin, C. (2016). Characterization of spots nickel-metal hybrid batteries and a preliminary economic evaluation of the recovery processes. Journal of the Air & Waste management Association, Volume 66, Issue 3, pp. 296-306. DOI: 10.1080/10962247.2015.1131206

Machacek and Kalvig (edit), 2017: EURARE. Development of a Sustainable Exploitation Scheme for Europe's Rare Earth Ore Deposits European REE market survey – Task 1.1.2 [online] Available at: [http://www.eurare.eu/docs/T1.1.2\\_Report-final-280217.pdf](http://www.eurare.eu/docs/T1.1.2_Report-final-280217.pdf)

Mancheri et al. (2019) Effect of Chinese policies on rare earth supply chain resilience, Mancheri, Nabeel ; Sprecher, Benjamin ; Bailey, Gwendolyn ; Tukker, Arnold, Elsevier, Resources Conservation And Recycling; 2019; Vol. 142; pp. 101 - 112 [online] Available at: <https://doi.org/10.1016/j.resconrec.2018.11.017>

Massari et al. (2013). Rare earth elements as critical raw materials: Focus on international markets and future strategies, S. Massari and M. Ruberti, Resour. Policy, 2013, 38(1), 36-43.

McKinsey (2012) Lighting the way: Perspective on the global lighting market. Available at: [https://www.mckinsey.com/~media/mckinsey/dotcom/client\\_service/automotive%20and%20assembly/lighting\\_the\\_way\\_perspectives\\_on\\_global\\_lighting\\_market\\_2012.ashx](https://www.mckinsey.com/~media/mckinsey/dotcom/client_service/automotive%20and%20assembly/lighting_the_way_perspectives_on_global_lighting_market_2012.ashx)

Metall Rare Earth Ltd. (2017) Retrieved on February 8, 2017 from <http://www.metall.com.cn>

MIIT (2016) Rare Earth Development Plan, 2016–2020 (In Chinese) Ministry of Industry and Information Technology, China (2016). [www.miit.gov.cn/n1146295/n1652858/n1652930/.5287774.doc](http://www.miit.gov.cn/n1146295/n1652858/n1652930/.5287774.doc)

Minerals4EU (2019) European Minerals Yearbook. Available at: [http://minerals4eu.brgm-rec.fr/m4eu-yearbook/theme\\_selection.html](http://minerals4eu.brgm-rec.fr/m4eu-yearbook/theme_selection.html) (Accessed: 9 July 2019).

Mining Journal (2015) Molycorp Placing Mountain Pass on Care and Maintenance [online] Available at: [www.e-mj.com/news/us-a-canada/5602-molycorp-placing-mountain-pass-on-care-and-maintenance.html#.WKvs1W\\_hCos](http://www.e-mj.com/news/us-a-canada/5602-molycorp-placing-mountain-pass-on-care-and-maintenance.html#.WKvs1W_hCos)

Mintek (2013). Email correspondence regarding REE processing steps with information (see Machacek and Kalvig (edit), 2017: EURARE)

MSE Supplies (2017) Retrieved on February 8, 2017 from <https://www.msесupplies.com/>

Niron Magnetics (2020) Retrieved on 17 February 202 from. <https://nironmagnetics.com/>

OECD (2019). Export restrictions on Industrial Raw Materials [Online]. Available at: [https://qdd.oecd.org/subject.aspx?Subject=ExportRestrictions\\_IndustrialRawMaterials](https://qdd.oecd.org/subject.aspx?Subject=ExportRestrictions_IndustrialRawMaterials) (Accessed: 03.09.2019)

- OICA (2015). Available at: <http://www.oica.net/category/production-statistics/2015-statistics/>
- Panadyne Abrasives (2012-2016) All products. Cerium oxide 99.9% Purity <6um – 1 Lb. Retrieved on September 19, 2016 from <https://www.panadyneabrasives.com/Cerium-Oxide-999-Purity-6um-1-Lb-Ce99O1Lb.htm>
- Powder Metallurgy Review (2016) The Powder Metallurgy Review magazine archive. Available at: <https://www.pm-review.com/powder-metallurgy-review-archive/2016-archive/>
- Rare Earth Investing News (2016) Available at: <https://investingnews.com/category/daily/resource-investing/critical-metals-investing/rare-earth-investing/>
- Rare Earth Technology Alliance (2014) The Economic Benefits of the North American Rare Earths Industry. American Chemistry Council.
- Riddle et al. (2015). Matthew Riddle, Charles M. Macal, Guenter Conzelmann, Todd E. Combs, Diana Bauer, Fletcher Fields, Global critical materials markets: An agent-based modeling approach, *Resources Policy*, Volume 45, 2015, Pages 307-321, ISSN 0301-4207, <https://doi.org/10.1016/j.resourpol.2015.01.002>. Available at : <http://www.sciencedirect.com/science/article/pii/S0301420715000070>)
- Ronning (2014). Rare earth replacement magnets. Filip Ronning and Sam Bader. Published 27 January 2014. 2014 IOP Publishing Ltd.
- Roskill (2011) Rare Earth & Yttrium: Market Outlook to 2015, Fourteenth Edition, 2011. ISBN 978 086214 565 1.
- Roskill (2015) Rare Earths: Market outlook to 2020. Fifteenth Edition. Roskill Information Services Ltd.
- Roskill (2016). Rare earths: Global industry, markets and outlook. Sixteenth Edition. London, UK: Roskill.
- Roskill (2019). Rare Earths: Outlook to 2029. Nineteenth Edition. Roskill Information Services Ltd. ISBN 978 1 910922 80 4.
- Rudnick, R.L. and Gao, S. (2003). Composition of the Continental Crust. In: *Treatise on Geochemistry*, Volume 3. Editor: Roberta L. Rudnick. Executive Editors: Heinrich D. Holland and Karl K. Turekian. pp. 659. ISBN 0-08-043751-6. Elsevier, p.1-64.
- Samouhos, M., Taxiarchou, M., Paspaliaris, I., Karhu, M., Bourg, S., Bouyer, E., Sundqvist, L. Roadmap and innovation pathways for technology development in CRMs. Deliverable 6.4 of the SCRREEN project funded through the European Union's Horizon 2020 research and innovation programme under grant agreement No 730227.
- Schüler D. Buchert M., Liu R., Dittrich S., Merz C. (2011) Study on Rare Earths and Their Recycling, Final Report for the Greens/EFA Group in the European Parliament, Öko Institut e. V., pp. 140
- SCRREEN workshop. (2019). "Validation Workshop on Critical Raw Materials, 10-12 September 2019, Thon Hotel Brussels City Centre."
- Sethurajan, M., van Hullebusch, E. D., Fontana, D., Akcil, A., Deveci, H., Batinic, B., Leal, J. P., Gasche, T. A., Kucuker, M. A., Kuchta, K., Neto, I. F. F., Soares, H. M. V. M., Chmielarz, A. (2019): Recent advances on hydrometallurgical recovery of critical and precious elements from

end of life electronic wastes - a review, *Critical Reviews in Environmental Science and Technology*, DOI:10.1080/10643389.2018.1540760

Tercero Espinoza, L.; Stotz, H.; Deubzer, O.; Barros García, R.; Rodríguez Lepe, G.; Bilewska, K.; Osadnik, M.; Mazur, J.; Sundqvist Ökvist, L.; Eriksson, J.; Hu, X. (2016): Critical Raw Materials substitution profiles. Deliverable 5.1 of the SCRREEN project funded through the European Union's Horizon 2020 research and innovation programme under grant agreement No 730227.

Trigueiro F.E., Falabella Sousa-Aguiar, E., Zotin, F.M.Z. (2013). The role of rare earth elements in zeolites and cracking catalysts. *Catalysis Today*, Volumes 218-219, pp. 115-122. DOI: 10.1016/j.cattod.2013.06.021

Umicore (2016). Neodymium [online] Available at: <http://www.umicore.com/en/about/elements/neodymium>

UNEP (2013). Metal Recycling - Opportunities, limits, infrastructure. A Report of the Working Group on the Global Metal Flows to the International Resource Panel. [online] Available at: <http://web.unep.org/publications/>

USGS (2017). Minerals Yearbook. [2017 tables-only release](#).

USGS (2017b). Van Gosen, B.S., Verplanck, P.L., Seal, R.R., II, Long, K.R., and Gambogi, Joseph, 2017, Rare-earth elements, chap. O of Schulz, K.J., DeYoung, J.H., Jr., Seal, R.R., II, and Bradley, D.C., eds., *Critical mineral resources of the United States—Economic and environmental geology and prospects for future supply*: U.S. Geological Survey Professional Paper 1802, p. O1–O31, <https://doi.org/10.3133/pp18020>.

USGS (2019). Mineral Commodity Summaries – Rare Earth Elements. Available at: <https://prd-wret.s3-us-west-2.amazonaws.com/assets/palladium/production/atoms/files/mcs-2019-raree.pdf> USGS (2020). Mineral commodity summaries 2020: U.S. Geological Survey, 200 p., <https://doi.org/10.3133/mcs2020>.

Wall F. (2014). Rare earths elements. In *Critical Minerals Handbook*. ed. G. Gunn. Publisher J. Wiley & Sons. Chapter 15 pp 535-575.

Wang, He et al. (2014). "Iron nitride permanent magnet and technique for forming iron nitride permanent magnet," ed: Google Patents, 2014. J.P. Wang, S. He et al.

Weng et al. (2015) A Detailed Assessment of Global Rare Earth Element Resources: Opportunities and Challenges\*. Weng, Zhehan; Jowitt, Simon M; Mudd, Gavin M; Haque, Nawshad, *Economic Geology*, v. Available at: <http://econgeol.geoscienceworld.org/>. (Accessed: 31 January 2020).

Widmer et al. (2015) Widmer, J.D., Martin, R., Kimiabeigi, M. Electric vehicle traction motors without rare earth magnets. *Sustainable Materials and Technologies*, Volume 3, 2015, Pages 7-13, ISSN 2214-9937. <https://doi.org/10.1016/j.susmat.2015.02.001>.

WMD (2019) World Mining Data 2019, Reichl, C.; Schatz, M; Zsak, G. Iron and Ferro Alloy Metals, non Ferrous Metals, Precious Metals, Industrial Minerals, Mineral Fuels. Austrian Federal Ministry of Sustainability and Tourism. [online] Available at: [www.en.bmwfw.gv.at/Energy/WorldMiningData/Seiten/default.aspx](http://www.en.bmwfw.gv.at/Energy/WorldMiningData/Seiten/default.aspx)

Yoldjian (1985). The use of rare earths in ceramics, *Journal of the Less-Common Metals*, 111; 17 – 22

Zion Market Research (2019). Zion Market Research website, available at: <https://www.zionmarketresearch.com/news/rare-earth-metals-market>.

### 21.7.2 Data sources used in the criticality assessment

The calculation of economic importance is based on the use of the NACE 2-digit codes and the value added at factor cost for the identified sectors (See chapter 3.2 for the applications, 2-digit NACE sectors and value added per sector for each rare earth element). The value added data correspond to 2013 figures.

Data sources for the estimation of REE supply are summed up in Table 180.

**Table 180: Sources of data for the estimation of REE supply.**

		Data for all REEs (mixed)		Data for individual REEs	
		Nature of data	Data source	Nature of data	Data source
Scope of supply	Global	Production	BGS, USGS, Roskill, BRGM, ASTER project	Relative concentration of the individual REE in the total world production of REEs	EC (2014) Report on critical raw materials
	EU	Imports to the EU	EUROSTAT	Share of the individual REE in the total EU use of REEs	ASTER project

The codes used for the EUROSTAT extraction (COMEXT database) and the REO content are reported in Table 181 (sources: Guyonnet et al., 2015; updated in Bio Intelligence Service, 2015 for the conversion factors).

**Table 182: EUROSTAT codes for REE and REO conversion factors**

NC8 Code	Description	Estimated REO conversion factor
28461000	Cerium compounds	0.72
28469000	Compounds, inorganic or organic, of rare-earth metals, of yttrium or of scandium or of mixtures of these metals (excl. cerium)	0.63



The disaggregation factors for individual REEs reported in Table 183 were estimated according to TMR Advanced Rare-Earth Projects Index<sup>243</sup> (TMR, 2015). The share of the individual REE in the total EU use of REEs is based on the ASTER project (Guyonnet et al., 2015).

**Table 183: Disaggregation factors for individual REEs**

<b>REE</b>	<b>Relative concentration of the individual REE in the total world production of REEs</b>	<b>Share of the individual REE in the total EU use of REEs</b>
La	24.5%	41.0%
Ce	44.3%	39.4%
Pr	4.7%	2.6%
Nd	15.8%	6.4%
Eu	0.4%	0.4%
Gd	1.4%	0.2%
Tb	0.2%	0.4%
Dy	0.9%	0.2%
Y	4.7%	8.8%
Sm	2.2%	0.4%
Er	0.4%	0.2%
Ho, Tm, Yb, Lu	0.6%	0.2%

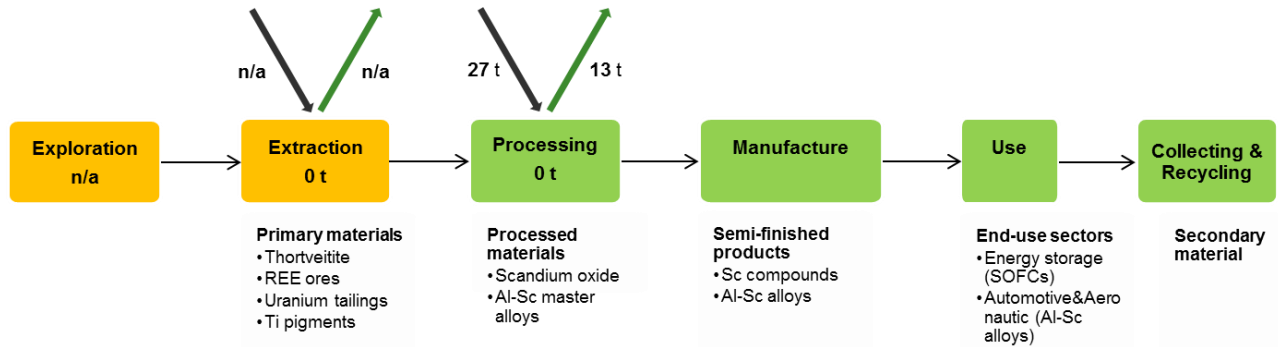
## 21.8 Acknowledgments

This factsheet was prepared by the DG GROW and DG JRC. The authors would like to thank particularly Dennis Bastian, Harald Elsner (DERA at BGR), Per Kalvig (GEUS), Nabeel Mancheri (REIA) and Ryan Castilloux (Adamas) for substantial inputs, the EC Ad Hoc Working Group on Critical Raw Materials, experts participating in the rare earths session at the SCRREEN workshop and all other relevant stakeholders for their contributions to the preparation of this Factsheet.

<sup>243</sup> <http://www.techmetalsresearch.com/metrics-indices/tmr-advanced-rare-earth-projects-index/> last updated on November 19, 2015, (Accessed June 2019).

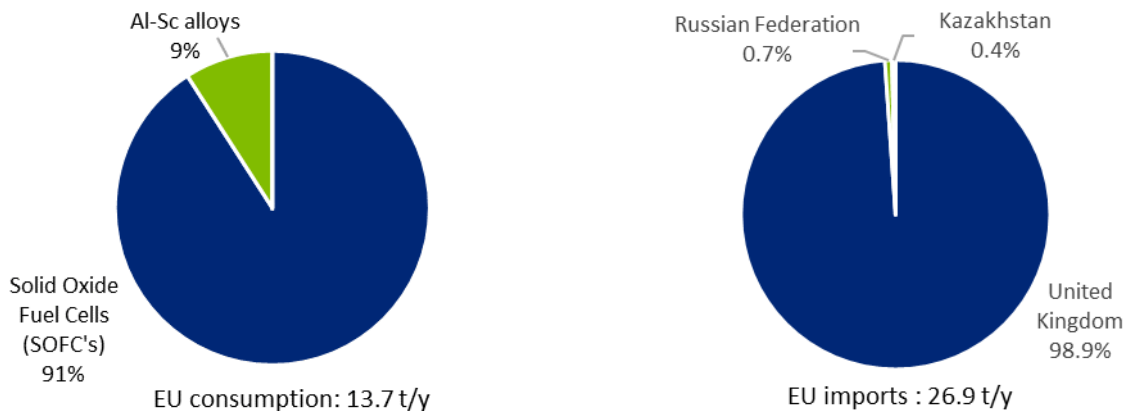
# 22 SCANDIUM

## 22.1 Overview



**Figure 449: Simplified value chain for scandium for the EU, averaged over 2012-2016**

Scandium (chemical symbol Sc, from the Latin 'Scandia' for Scandinavia where it was historically discovered) is a silvery-white light transition metal. Its main properties are its light weight (density of 2.99 g/cm<sup>3</sup>, close to the one of aluminium), high melting point (1,541 °C) and small ionic radius. Scandium is not particularly rare; its abundance in the upper continental crust is 14 ppm<sup>244</sup> (Rudnick, 2003). However, due to the small size of its ions, it does not selectively combine with the common ore-forming anions, and rarely forms concentrations higher than 100 ppm in nature. Consequently, scandium deposits are rare. It shares similar characteristics with Rare Earth Elements (REEs) but has quite specific mineralogical and industrial properties, which justify a distinct classification.



**Figure 450: End uses (Duyvesteyn & Putman, 2014; Lipman, 2017; European Commission, 2014) and EU sourcing of scandium, processing stage (Eurostat, 2019), average 2012-2016**

For the purpose of this assessment, scandium metal at processing stage is analysed. The product codes considering scandium at this stage are CN 2805 30 40 "Scandium, of a purity by weight

<sup>244</sup> parts per million

of  $\geq 95\%$  (excl. intermixtures and interalloys)" and CN 2846 90 30 "Scandium compounds, inorganic or organic" (Eurostat, 2019).

Scandium exhibits typical characteristics and challenges of a small, immature and undeveloped commodity market, meaning that lack of demand suppresses supply and non-existent supply reciprocally inhibits possible future demand. On the demand side, the main potential driver would be a growth in the use of scandium-aluminium alloys in aerospace and automotive applications, but market prices for scandium were considered by analysts too high and did not decrease as expected. On the supply side, much work is underway to study the potential for new multiple and reliable supply sources of scandium. Various players and countries have launched research on the recovery of scandium, notably from red mud caustic wastes. Several projects are currently developed to recover scandium mainly from secondary resources, but also primary resources, in Australia and the United States. As the scandium market is very small, and enough scandium is (currently) supplied, the mid-term success of the Nyngan and the other projects remains uncertain.

Depending on the products, prices for 2012-2018 period were of the following ranges:

- scandium oxide at 99.99% grade: US\$4,600–5,400 per kilogram, when in 2010 it was US\$1,620 per kilogram;
- aluminum-scandium master alloy (2% scandium): US\$155-386 per kilogram.

Those prices remain too high to enable widespread commercial adoption of scandium, in alloy applications in particular. Scandium oxide prices were reported to drop by 35% in the period October 2018 to September 2019 compared to the period 2014-2018.

The total apparent consumption of scandium in the EU is around 13.7 tonnes per year. As there is no EU domestic production of scandium, this is exclusively reasoned by the excess of imports. According to the foreign trade data, United Kingdom appears by far the most important supplier of scandium to the EU, taking almost 98% (26.6 tonnes per year) of the imports to the EU. The quality of the trade data (Comext: scandium  $\geq 95\%$  and scandium compounds), is estimated weak, but could not be replaced by better official data: especially the magnitude of the United Kingdom supply is very questionable. Further, minor source countries are Russia, Kazakhstan, United States and Hongkong. The world's main producers of scandium, China (around 10 tonnes per year), seems to direct its extractions and/or production to other destinations outside the EU or to use the commodity itself. This is the same for Ukraine although the production is much lower (around 1.0 tonne per year).

According to Lipmann Walton & Co (2016), the lion's share (90%) of total annual production in recent years would be absorbed by use in Solid Oxide Fuel Cells (SOFCs). There are a number of types of fuel cells, but SOFC design appears to be the current leader.

In SOFCs, yttrium and scandium can be used alternatively because they play the same role in stabilizing the zirconia-based electrolyte. The use of one or the other also depends on performance, price, or availability criteria and can evolve in time. However, In high-performance alloys, substitutes for scandium could be titanium, lithium (especially for aluminium alloys) or carbon fibre materials. They achieve comparable results in terms of resistance and low weight for aerospace and automotive structures.

In most of its applications, the use of scandium is a way to innovate and enhance performances and properties of already existing end-products. Therefore, this material could be considered as a substitute itself and alternatives exist for almost all of its uses. The choice is either driven by performance, price, or availability.

Aluminium-scandium alloys can help to minimise the weight of vehicles and thus the specific energy consumption, and SOFCs with scandium can contribute to push alternative engines. However, a drop in price would be crucial to increase the number of related vehicle units.

On a global scale, resources of scandium are abundant. There are identified scandium resources in Australia, Canada, China, Kazakhstan, Madagascar, Norway, the Philippines, Russia, Ukraine, and the United States.(Gambogi, 2017). The global reserves of scandium are not available.

Due to the lack of officially reported updated data, the assessment refers to the data of the previous one. Accordingly, it is estimated that two thirds of global production is located in China, followed by Russia with about a quarter of the global production. The Ukrainian production is from the tailing of an iron mine is estimated at 7%. However, at the validation workshop this production is said to be stopped in about 2017 (BRGM 2017).

Scandium is mostly won from secondary resources through hydrometallurgical processes, while pyrometallurgical processes are applied for recovery of scandium from primary sources (thortveitite). This latter route is energy intensive and therefore rare. Relevant secondary sources are: slags, residues, tailings and waste liquors of various metals. The processes applied there mainly involve leaching, solvent extraction, precipitation and calcination methods (Wang *et al.*, 2011). In recent years, the most single important source of secondary production comes from REE and iron ore processing in Bayan Obo (China).

Until some years ago, recycling of scandium in end-of-life products nor in 'new scrap' was known, due to its limited usage (UNEP, 2013). Over time, certain recycling routes have been developed for old scrap, namely car catalysts and as Al-Sc alloys. A bottleneck for recycling is the missing economy of scale due to the low market maturity.

## **22.2 Market analysis, trade and prices**

---

### **22.2.1 Global market analysis and outlook**

Scandium exhibits typical characteristics and challenges of a small, immature and undeveloped commodity market, meaning that lack of demand suppresses supply and non-existent supply reciprocally inhibits possible future demand. Having said that, rapid rise in supply by e.g. new mines can act the market price under pressure.

On the demand side, the main potential driver would be a growth in the use of scandium-aluminium alloys in aerospace and automotive applications. A landmark was achieved by the EU-based company Airbus which developed Scalmetalloy™ alloy family since 2012, with registration of the patent in 2014. In the past, analysts judged that prices for scandium had remained much too high to enable widespread commercial adoption and other materials compete directly (in particular the aluminium-lithium alloy family). The same reasoning applies for development of the SOFCs market. Until 2018, prices for scandium-aluminium alloy have not significantly increased thus the situation remained basically unchanged (Gambogi, 2019).

On the supply side, much work is underway to study the potential for new multiple and reliable supply sources of scandium. Various players and countries have launched research on the recovery of scandium, notably from red mud caustic wastes (notably in Russia, with the support of the major aluminium producer UC Rusal, as well as in Quebec, Canada). Other research projects are active in Japan, the Philippines, Kazakhstan, or Ukraine on scandium recovery from uranium tailings, sulphate titanium wastes, or nickel-laterites (Gambogi, 2016). The development and outcomes of these projects should be closely followed.

In terms of scandium exploration, as main or by-product, various projects are worth mentioning, among them four projects in Australia:

- Nyngan project, New South Wales;
- Clean TeQ, Syerston scandium project near Condoblin, central New South Wales;
- Sconi project, in northern Queensland.

In spite of efforts, so far no mine production of scandium has been reported in Australia. The feasibility and economic assessment of the Nyngan scandium project was completed, and a mining lease was already granted. The reserves were estimated to contain about 590 tonnes of scandium (1.4 Mtonnes ore, cut-off grade 155 ppm scandium). The developer expected the beginning of the production in 2019, however, this was still subject to financing. The production volume expected is 38.5 tonnes per year of scandium oxide. An expert stated at the validation workshop that this new Australian mine claims that Airbus will be their main customer. The Syerston project is also under development, but less close to opening with a cut-off grade of 300 ppm scandium. (Gambogi, 2019)<sup>245</sup>

In the United States, developers of multimetallic deposits, including the Round Top project in Texas and the Elk Creek project in Nebraska, were examining the incorporation of scandium recovery into project plans (Gambogi, 2016).

As the scandium market is very small, and enough scandium was supplied in ..., the mid-term success of the Nyngan and the other projects remains uncertain.

**Table 184: Qualitative forecast of supply and demand of scandium**

Materials	Criticality of the material in 2020		Demand forecast			Supply forecast		
	Yes	No	5 years	10 years	20 years	5 years	10 years	20 years
Scandium	X		?	?	?	?	?	?

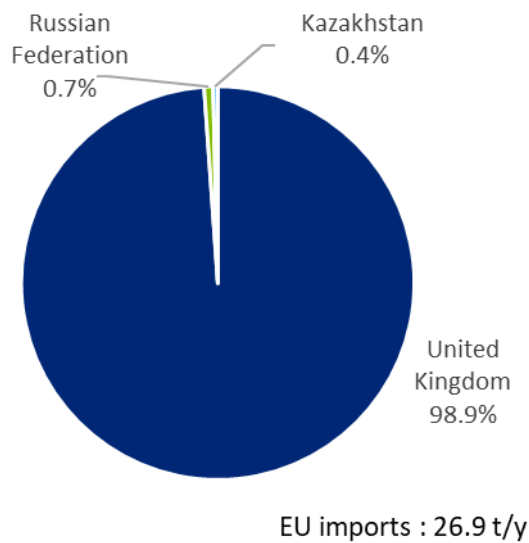
## 22.2.2 EU trade

Only since 2016, scandium specific trade codes are applied at Eurostat Comext by the introduction of codes on pure scandium (CN 2805 30 40) and scandium compounds (CN 2846 90 30)<sup>246</sup>. Previous estimates by Lipman for Russia (200 kilogram per year) and Kazakhstan (100 kilogram per year), mainly in the form of scandium oxide, were maintained aiming to complete the uncertain data set. According to this joint dataset, the United Kingdom is by far the most important supplier of scandium to the EU, taking almost 99% (26.6 tonnes per year) of the imports to the EU, averaged over 2012-2016 (see Figure 451) (Eurostat, 2019). Minor source countries are Russia, Kazakhstan, United States and Hongkong. As the United Kingdom does not have own scandium production, the supply are considered re-exports. The world's main producers of scandium, China, seems to direct its extractions to other destination outside the EU or use the commodity themselves.

In terms of trade restrictions, Chinese export quotas on REEs also applied to scandium. These were lifted in 2015, replaced by resources taxes based on sales value (Metal Pages, 2015). At the moment, there are no export quotas or prohibition in place between the EU and its suppliers (OECD, 2016). From the EU's suppliers, only China has an export tax ( $\leq 25\%$ ) (OECD, 2016).

<sup>245</sup> [https://www.usgs.gov/centers/nmic/scandium-statistics-and-information?qt-science\\_support\\_page\\_related\\_con=0#qt-science\\_support\\_page\\_related\\_con](https://www.usgs.gov/centers/nmic/scandium-statistics-and-information?qt-science_support_page_related_con=0#qt-science_support_page_related_con)

<sup>246</sup> EU trade is analysed using product group codes. It is possible that materials are part of product groups also containing other materials and/or being subject to re-export, the "Rotterdam-effect". This effect means that materials can originate from a country that is merely trading instead of producing the particular material.



**Figure 451: EU imports of scandium oxides, average 2012-2016 (Eurostat, 2019)<sup>247</sup>**

### 22.2.3 Prices and price volatility

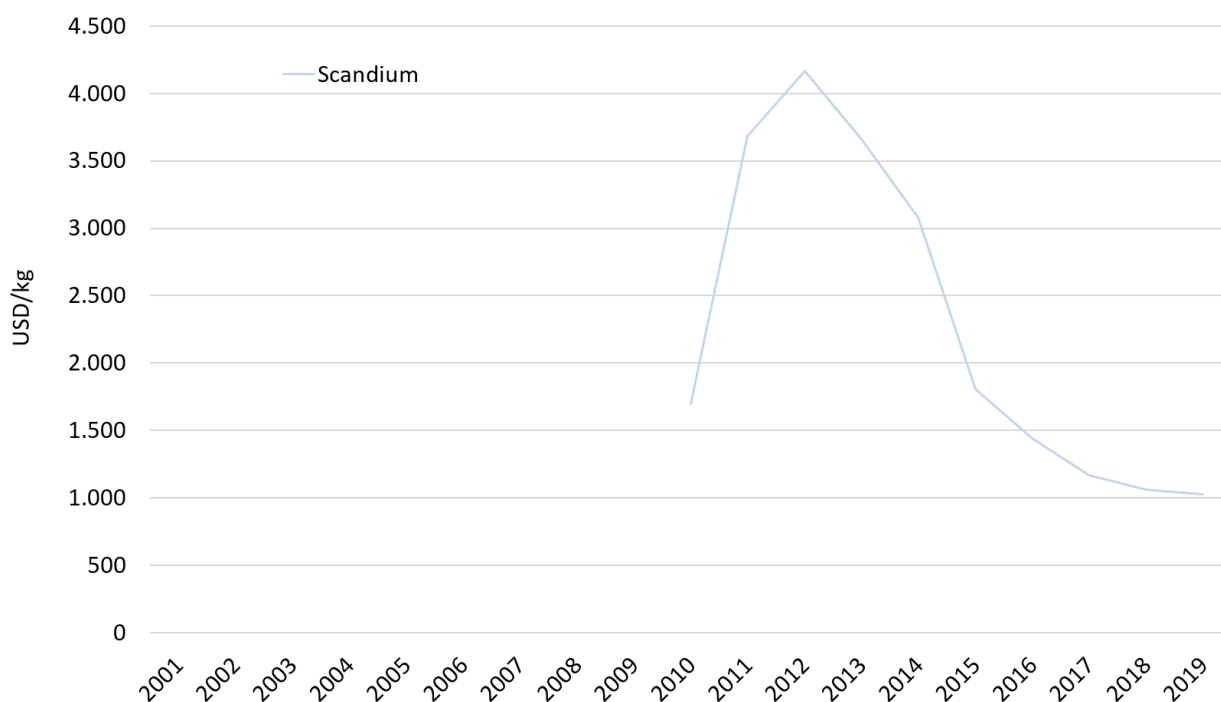
Scandium is not traded on any metals exchange, and there are no terminal or futures markets where buyers and sellers can fix an official price. Scandium products are sold between private parties at undisclosed prices.

A way to estimate scandium metal or oxide prices is to simulate a purchase to specialized suppliers. In this way USGS determines some prices and publishes also for scandium products, based on consultation of a specialist supplier (Stanford Materials Corp.). Depending on the products, prices for 2011-2018 period were of the following ranges (Gambogi, 2016; Gambogi, 2019):

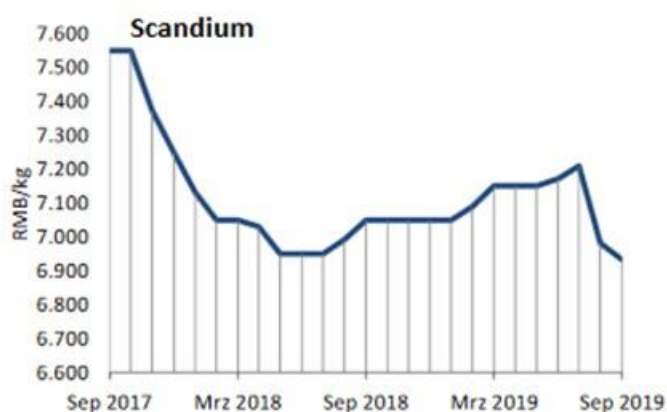
- scandium oxide at 99.99% grade (4N): US\$4,600–5,400 per kilogram, when in 2010 it was US\$1,620 per kilogram;
- aluminum-scandium master alloy (2% scandium): US\$155-386 per kilogram.

Those prices remain too high to enable widespread commercial adoption of scandium, in alloy applications in particular. Scandium oxide prices were reported to drop (Asian Metal) strongly, i.e. by 35% in the period October 2018 to September 2019 compared to the period 2014-2018.

<sup>247</sup> in combination with a hypothesis on consumption and EU imports, based on expert communication (Lipmann Walton & Co)



**Figure 452: Annual average prices of 99% scandium oxide in US\$ per kilogram from 2010 to 2019 (FOB China) (DERA, 2019)**



**Figure 453: Price development of Scandium (oxides), min. 99.5%, China (Asian Metal).(after BGR, 2019)**

## 22.3 EU demand

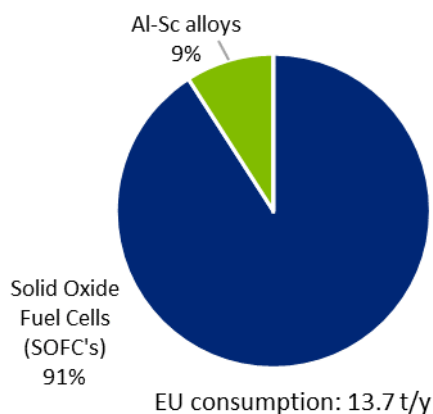
### 22.3.1 EU demand and consumption

Most of the imported quantities (a few hundred tonnes) are currently used either in R&D projects or in small markets (scandium-aluminium alloys, SOFCs) or minor other applications, such as high-quality sports equipment.

Due to the very high import values from United Kingdom, apparent consumption is determined as around 14 tonnes per year, averaged over 2012-2016. In spite of missing plausibility, there were in 2019 no better data available on EU consumption.

### 22.3.2 Uses and end-uses of Scandium in the EU

According to Lipmann Walton & Co (2016), the lion's share (90%) of total annual production in recent years would be absorbed by use in Solid Oxide Fuel Cells (SOFCs) as shown in the Figure 454. The apparent EU consumption of scandium is 13.7 tonnes per year between 2012 and 2016.



**Figure 454: Global end uses of scandium. Average figures for 2012-2016 (Data from Duyvesteyn & Putman, 2014, Lipman Walton & Co., 2017, and , EC, 2014)<sup>248</sup>**

Fuel cells, in particular SOFCs, are seen as a promising alternative electrical power supply, notably for automotive transportation. There are a number of types of fuel cells, but SOFC design appears to be the current leader.

In general terms, a fuel cell is an electrochemical cell that converts a fuel source and an oxygen source into an electrical current, plus water, CO<sub>2</sub> and heat. It does this by promoting reactions between the fuel and oxidant (reactants), which are triggered by a very high temperature environment (1,000 °C). The central part of a SOFC is a solid electrolyte generally composed of zirconia. However, zirconia would never withstand high operating temperatures without being stabilized with a metal. The stabilizing and conducting metal of choice for the electrolyte has traditionally been yttrium. Its advantages are its relative abundance (global production of around 8,000-10,000 tonnes per year) and low price (at around US\$40-60 per kg, 100 times lower than scandium oxide). But, since the price spike on REEs and yttrium in 2011, scandium was given more attention to be the stabilizing agent for zirconia. Although playing the same role, it lowers the operating temperature of the cell and increases its lifespan and efficiency by improving the power density. Scandium proved to be a considerably better ionic electrical conductor than yttrium and more importantly, scandium allows the electrolyte to conduct at significantly lower temperatures (750-800 °C) so that the cost, efficiency and lifespan of materials for thermal shielding can be reduced (Duyvesteyn, 2014). Barriers for expansion of scandium in this market remain price and availability of this element.

There are more than hundred companies designing SOFCs today. The technical leader in commercial SOFC technology is Bloom Energy, a private company headquartered in Sunnyvale, California (Bloom Energy, 2016).

The second most important use application is as alloying element combined with aluminium. Aluminium-scandium (and magnesium) alloys are amongst the lightest metal resources known

<sup>248</sup> At the validation workshop, the data was estimated by an expert as "outdated", but no better data was provided or promised. Therefore, the data is kept as "best available" estimate also for the period 2012-2016.



and could help increasing fuel efficiency in aerospace and automotive transportation. Small additions of scandium have the most promising effect on aluminum alloys, as this allows obtaining materials with a significantly improved set of properties. Scandium refines the crystal structure of aluminium to the point where the alloyed metal can be welded without loss in strength. It also increases plasticity in the moulding of complex shapes, improves corrosion resistance, and increases thermal conductivity. An extension in use to structural materials for aerospace engineering could develop in the future. In 2014, Airbus patented and developed Scalmalloy™, a specific scandium-magnesium-aluminium alloy family for use in aerospace (Airbus, 2016). However, aluminium-scandium alloys' are still extremely expensive, and the main market at present is mostly high-quality sports equipment (bikes, baseball bats, etc.).

The calculation of economic importance is based on the use of the NACE 2-digit codes and the value added at factor cost for the identified sectors (Table 185).

**Table 185: Scandium applications, 2-digit NACE sectors, associated 4-digit NACE sectors, and value added per sector**

<b>Applications</b>	<b>2-digit NACE sector</b>	<b>4-digit NACE sector</b>	<b>Value added of sector (M€)</b>
Solid Oxide Fuel Cells (SOFCs)	C27 - Manufacture of electrical equipment	27.90 - Manufacture of other electrical equipment	80,745
Al-Sc alloys	C25 - Manufacture of fabricated metal products, except machinery and equipment	25.11 - Manufacture of metal structures and parts of structures	148,351

Other minor use applications of scandium in the form of metal or metal oxide include titanium-scandium carbides, GSGG lasers, mercury vapor high-intensity light, tracing agents in oil refining, or dopants in special glasses, glazes, and ceramic products (Gambogi, 2016). Scandium is also used for the manufacture of ferrites with low induction for computer memory elements (Intermix Met, 2016).

### **22.3.3 Substitution**

As the use of scandium is new and still a "niche market", the use of scandium is in most of its applications a way to innovate and enhance performances and properties of already existing end-products. Therefore, scandium is rather considered as a substitute itself, and alternatives exist for almost all of its uses. The decision for scandium at the choice of material is mainly driven by performance, price, or availability.

In high-performance alloys, substitutes for scandium can be titanium, lithium (especially for aluminium alloys) or carbon fibre materials. They achieve comparable results in terms of resistance and low weight for aerospace and automotive structures. Titanium and aluminum high-strength alloys, as well as carbon-fiber materials, may substitute in high performance scandium-alloy applications (Gambogi, 2019).

In SOFCs, yttrium and scandium can be used alternatively because they play the same role in stabilizing the zirconia-based electrolyte. The use of one or the other also depends on performance, price, or availability criteria and can evolve in time.

In some applications, however, that rely on scandium's unique properties, substitution is not possible (Gambogi, 2019).

## 22.4 Supply

---

### 22.4.1 EU supply chain

There is no mining of scandium and no production in the EU. The import reliance of EU-27 for scandium is 100%.

Scandium specific trade codes are applied at Eurostat Comext by the introduction of codes on pure scandium (CN 2805 30 40) and scandium compounds (CN 2846 90 30). Previous estimates for Russia (200 kilogram per year) and Kazakhstan (100 kilogram per year), mainly in the form of scandium oxide, based on expert consultation were maintained aiming to complete the uncertain data set on imports (Lipmann, 2016). According to this joint dataset, the United Kingdom is by far the most important supplier of scandium to the EU, taking almost 98% (26.6 tonnes per year) of the imports to the EU<sup>249</sup>, which is almost double the reported global production. The quality of the trade data is estimated weak, but no better official data was available; especially the magnitude of the United Kingdom supply is very questionable. Further, minor source countries are Russia (0.2 tonne per year), Kazakhstan, United States and Hongkong (each 0.1 tonne per year).

Not much is known about scandium transformation in the EU. At present, it is still commercialized at a very modest level, focusing more attention at the R&D level, both for uses in alloys and Solid Oxide Fuel Cells (SOFCs). The EU-based company Airbus developed the Scalmalloy™ alloy family since 2012, with registration of the patent in 2014 (Airbus, 2016). But only one company is known to offer patented Scalmalloy™ alloys for sale, namely RSP Technology<sup>250</sup> in the Netherlands.

SCALE is an EU funded project that aims for efficient exploitation of a selection of high concentration scandium containing resources including bauxite residues from alumina production and acid wastes from TiO<sub>2</sub> pigment production. Based on a number of innovative extraction, separation, refining and alloying processes, the project investigates options for improvements along the overall supply chain with the ultimate goal to develop a stable and secure EU scandium supply chain to serve the needs of EU aerospace and high tech industry. This requires also the establishment of the foundation for a European scandium industry.

In terms of trade restrictions, Chinese export quotas on REEs also applied to scandium. These were lifted in 2015, replaced by resources taxes based on sales value (Metal Pages, 2015). At the moment, there are no export quotas or prohibition in place between the EU and its suppliers (OECD, 2016). From the EU's suppliers, only China has an export tax ( $\leq 25\%$ ) (OECD, 2016).

### 22.4.2 Supply from primary materials

#### 22.4.2.1 Geology, resources and reserves of scandium

**Geological occurrence:** In the continental crust, scandium is essentially a trace constituent of igneous rocks ferromagnesian minerals. Scandium concentrations in these minerals (amphibole-hornblende, pyroxene, and biotite) are typically in the range of 5-100 ppm equivalent Sc<sub>2</sub>O<sub>3</sub>.

---

<sup>249</sup> Experts estimated the car catalyst recyclers as potential source.

<sup>250</sup> Website: [www.rsp-technology.com](http://www.rsp-technology.com)

Genetic types of scandium deposits are difficult to classify (Borisenko, 1989) because this element is widely dispersed in the lithosphere and forms solid solutions in over hundred minerals such as rare-earth minerals, wolframite-columbite, cassiterite, beryl, garnet, muscovite, and the aluminum phosphate minerals. Scandium is also often associated with the elements fluorine and titanium in magmatic and sedimentary processes and can be found in numerous types of deposits (Hocquard, 2003). In the past, some scandium production has been generated from the scandium-yttrium silicate mineral, thortveitite (Crystal Mountain, United States). Some current exploration projects notably in Australia focus on nickel and cobalt lateritic deposits with high scandium concentrations (Duyvesteyn, 2014).

Scandium is also concentrated during the processing of various ores, specifically uranium, thorium, aluminium, tungsten, tin, tantalum, titanium and REE's, which are the main sources of supply.

**Global resources and reserves<sup>251</sup>:** The world resources of scandium are abundant. There are identified scandium resources in Australia, Canada, China, Kazakhstan, Madagascar, Norway, the Philippines, Russia, Ukraine, and the United States. The global reserves of scandium are not available. (Gambogi , 2019)

**EU resources and reserves<sup>252</sup>:** The Minerals4EU website does not display data about resources and reserves of scandium for Europe. In Finland, a resource of 13.4 Mtonnes is reported for the Kiviniemi deposit with a grade of 0.01627% scandium (Hokka et al. 2016).

**Table 186: Resource data for the EU on Scandium**

Country	Reporting code	Quantity	Unit	Grade	Code Resource Type
Finland	non-compliant code	13.4	Mtonnes	0.01627%	inferred

#### 22.4.2.2 World and EU mine production

There are no scandium mines known globally, but all scandium is won as by-product (BRGM 2017). Various independent authors quote global market volumes of 2-10 tonnes per year. The

<sup>251</sup> There is no single source of comprehensive evaluations for resources and reserves that apply the same criteria to deposits of vanadium in different geographic areas of the EU or globally. The USGS collects information about the quantity and quality of mineral resources but does not directly measure reserves, and companies or governments do not directly report reserves to the USGS. Individual companies may publish regular mineral resource and reserve reports, but reporting is done using a variety of systems of reporting depending on the location of their operation, their corporate identity and stock market requirements. Translations between national reporting codes are possible by application of the CRIRSCO template.<sup>251</sup>, which is also consistent with the United Nations Framework Classification (UNFC) system. However, reserve and resource data are changing continuously as exploration and mining proceed and are thus influenced by market conditions and should be followed continuously.

<sup>252</sup> For Europe, there is no complete and harmonised dataset that presents total EU resource and reserve estimates for vanadium. The Minerals4EU project is the only EU-level repository of some mineral resource and reserve data for vanadium, but this information does not provide a complete picture for Europe. It includes estimates based on a variety of reporting codes used by different countries, and different types of non-comparable datasets (e.g. historic estimates, inferred reserves figures only, etc.). In addition, translations of Minerals4EU data by application of the CRIRSCO template is not always possible, meaning that not all resource and reserve data for vanadium the national/regional level is consistent with the United Nations Framework Classification (UNFC) system (Minerals4EU 2019). Many documented resources in Europe are based on historic estimates and are of little current economic interest. Data for these may not always be presentable in accordance with the UNFC system. However a very solid estimation can be done by experts.

estimate number of 15 tonnes (Lipmann, 2016) was confirmed by EMC Metals Corporation (Duyvesteyn, 2014) based on discussions with their potential customers, the level of metals trader activity and interest, and the fact that certain scandium consumers are believed to be sourcing their own scandium through small controlled recovery operations.

Chinese production would amount to 10 tonnes per year of  $\text{Sc}_2\text{O}_3$  (66%), mainly as a by-product of REEs extraction (Bayan Obo mine). Also from recovery of sulphate wastes from the manufacture of titanium pigments, or from residues of iron ore, zirconium, tungsten or bauxite production (BRGM 2017, Gambogi 2019). Russia produces 3-5 tonnes per year (33%), mainly from uranium mill tailings (Intermix Met, 2016) and apatite (Gambogi 2019). Kazakhstan is estimated to produce 100-200 kg scandium oxide annually (1%), also from uranium mill tailings (Lipmann, 2016, Gambogi 2019). Scandium is also extracted as by-product of uranium mining in Ukraine (Gambogi 2019). Small stockpiles of this material may exist in Russia, Ukraine and Kazakhstan. At the validation workshop, an expert mentioned that in Norway some scandium had been produced as by-product of uranium, for usage in lasers. Mine production data for 2018 were not available (Gambogi 2019).

### **22.4.3 Supply from secondary materials/recycling**

Until some years ago, recycling of scandium in end-of-life products nor in 'new scrap' was known, due to its limited usage (UNEP, 2013). Over time, certain recycling routes have been developed for old scrap.

#### **22.4.3.1 Post-consumer recycling (old scrap)**

Scandium was considered widely as not recyclable, accordingly scandium contained in waste ends up predominantly in landfill (European Commission, 2014).

Scandium can be potentially recycled from certain end-of-life products, namely from car catalysts, fuel cells and aluminium-scandium alloys. However, scandium recovery from Sc-Al alloys and  $\text{Sc}_2\text{O}_3$  is a complex issue as: (a) there is lack of information on the amount of Sc-containing electronic wastes and whether this materials are collected and processed by the recycling companies, (b) the number of specific cutting-edge devices containing scandium is small and therefore the potential recovery amounts are limited. Scandium in fuel cells is not recycled due to missing economy of scale.

We conclude that this recycling is still a niche activity, and neglectable or non-existent (Gambogi, 2019). Figures on recycling volumes are not available<sup>253</sup>.

#### **22.4.3.2 Industrial recycling (new scrap)**

It is very difficult to recover scandium contained in intermediates, mixed scrap etc., i.e. scraps that are processed by specialty chemicals companies (e.g. Johnson Matthey)(Fontboté 2019).

### **22.4.4 Processing of Scandium**

Pyrometallurgical processes are suitable for recovery of scandium from primary sources (thortveitite). This route is energy intensive and rare.

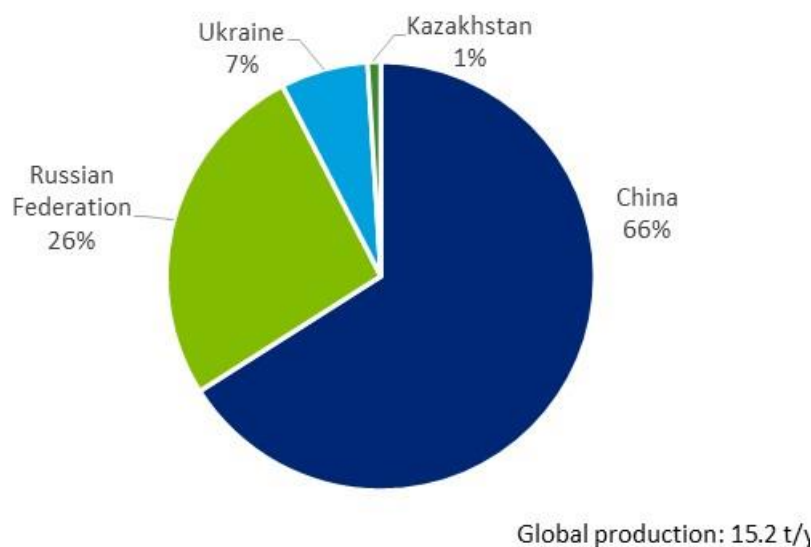
Hydrometallurgical processes are more widely used for scandium recovery from secondary sources (slags, residues, tailings and waste liquors of various metals). They mainly involve leaching, solvent extraction, precipitation and calcination methods (Wang et al., 2011). Most of

---

<sup>253</sup> The Material System Analysis (MSA-Sc2019) is still work in progress and was, at the time of the criticality assessment, not able to provide more insightful information.

the time, the first step is the precipitation of insoluble scandium compounds from scandium-containing solutions. The complexities of flowsheets to recover scandium depend on the amounts and types of impurities that can co-precipitate at this stage. Scandium oxide ( $\text{Sc}_2\text{O}_3$ ) is then obtained by thermal decomposition of the precipitate. After purification,  $\text{Sc}_2\text{O}_3$  is fluorinated to obtain an intermediate compound  $\text{ScF}_3$  (scandium fluoride). Scandium metal is produced by reducing  $\text{ScF}_3$  with calcium metal or by aluminothermic reduction. Aluminothermic reduction has the advantage of obtaining the aluminium-scandium alloy directly (Blazy, 2013).

In recent years, the most single important source of secondary production comes from REE and iron ore processing in Bayan Obo (China). In this case, REEs and scandium are extracted into solutions by roasting the ore in concentrated sulphuric acid at 250–300 °C and then leaching with water (Li et al., 2004).



**Figure 455: Estimation of global production capacity of processed scandium products. (Comtrade, 2019), average of year 2012-2016**

Figure 455 shows the estimation of global production capacity of processed scandium products. Due to lack of officially reported updated data, the assessment refers to the data of the previous one. Accordingly, two thirds of global production between 2012 and 2016 was located in China, followed by Russia with about a quarter of the global production. The Ukrainian production was from the tailing of an iron mine. For the period 2012-2016 it is estimated to 7%, however, at the validation workshop this production is said to be stopped in about 2017 (BRGM 2017).

## 22.5 Other considerations

### 22.5.1 Environmental and health and safety issues

Scandium is considered non-toxic, and it is not subject to restrictions by the REACH regulation (ECHA 2019). The median lethal dose ( $\text{LD}_{50}$ ) levels for scandium chloride for rats have been determined as 4 milligramme per kilogram for [intraperitoneal](#) and 755 milligramme per kilogram for oral administration (Haley et al., 1962).

EU occupational safety and health (OSH) requirements exist to protect workers' health and safety. Employers need to identify which hazardous substances they use at the workplace, carry out a risk assessment and introduce appropriate, proportionate and effective risk management

measures to eliminate or control exposure, to consult with the workers who should receive training and, as appropriate, health surveillance<sup>254</sup>.

### 22.5.2 Socio-economic issues

No specific issues were identified during data collection and stakeholders consultation.

## 22.6 Comparison with previous EU assessments

The assessment has been conducted using the same methodology as for the 2017 list. Supply risk has been analysed at processing stage.

The results of this and earlier assessments are shown in Table 187.

**Table 187: Economic importance and supply risk results for Scandium in the assessments of 2011, 2014, 2017, 2020 (European Commission, 2011; European Commission, 2014; European Commission, 2017)**

Assessment	2011		2014		2017		2020	
	EI	SR	EI	SR	EI	SR	EI	SR
Scandium	5.8	4.9	3.8	1.1	3.7	2.9	4.4	3.1

After decrease of the Economic Importance (EI) score for scandium between 2011 and 2017, the 2020 assessment shows a trend reversal. Supply Risk (SR) score, after a minimum in 2014, continued to increase modestly. The abrupt rise in SR after 2014 can partly be explained by a revised methodology that took into account new parameters such as the concentration of global production, the diversity of EU supply sources, and geopolitical risks. Thus it reflects, among others, the dominance of China on global production.

## 22.7 Data sources

Criticality assessment was performed at the stage of processing due to the better data availability than for the stage of extraction (no global information available) and the fact that it was judged as the main bottleneck for EU, as in the 2017 CRM assessment. Market shares and production data were in great part based on expert consultation (Lipmann, 2016).

Trade data is based on the Eurostat Comext dataset, which was significantly improved regarding scandium trade. At the 2017 CRM assessment, the Comext dataset did not allow evaluating imports quantities, as CN8 customs codes referring to scandium (CN 2805 30 10, 2805 30 90, 2846 90 00<sup>255</sup>) mixed various products with scandium being the least. Therefore, scandium imports to the EU were estimated based on expert consultation (Lipmann, 2016). However, new scandium trade codes on pure scandium (CN 2805 30 40 "scandium, of a purity by weight of  $\geq 95\%$  (excl. intermixtures and interalloys)") and scandium compounds (CN 2846 9030 "scandium compounds, inorganic or organic") were introduced, providing data more specific on scandium since 2016. Aiming for comprehensive data coverage, both new Comext data and hitherto used expert data (Lipmann, 2016) were combined. Information on export restrictions

<sup>254</sup> <https://ec.europa.eu/social/main.jsp?catId=148>

<sup>255</sup> CN 2805 30 10 "Intermixtures or interalloys of Rare Earth Metals, Scandium and Yttrium", CN 2805 30 90 "Rare Earth metals, Scandium and Yttrium (excl. intermixtures and interalloys)", CN 2846 90 00 "Compounds, inorganic or organic, of Rare Earth metals, of Yttrium or of Scandium or of mixtures of these metals (excl. Cerium)"

are derived from the OECD Export restrictions on the Industrial Raw Materials database (OECD, 2016). Data on trade agreements are taken from the DG Trade webpages, which include information on trade agreements between the EU and other countries (European Commission, 2016).

### **22.7.1 Data sources used in the factsheet**

Airbus (2016). Airbus Group technology licensing. Scalmalloy®RP aluminum-magnesium scandium alloy. [online] Available at: [www.technology-licensing.com/etl/int/en/What-we-offer/Technologies-for-licensing/Metallics-and-related-manufacturing-technologies/Scalmalloy.html](http://www.technology-licensing.com/etl/int/en/What-we-offer/Technologies-for-licensing/Metallics-and-related-manufacturing-technologies/Scalmalloy.html)

Blazy P., Hermant V. (2013). Ressources et métallurgie extractive du scandium. Éditions Techniques de l'Ingénieur, doc. M 2 357, pp.15

BGR (2019). Preismonitor September 2019 . Seltene Erden : Scandium (oxide). Deutsche Rohstoffagentur (DERA), Bundesanstalt für Geowissenschaften und Rohstoffe (BGR).

Bloom Energy (2016). Solid Oxide Fuel Cells for Energy [online] Available at: <http://www.bloomenergy.com/fuel-cell/solid-oxide-fuel-cell-animation/>

Borisenko L.F. (1989). Genetic types of scandium deposits. Inst. Mineral. Geochem. and Crystallochem. Rare Elements. Moscow, USSR, Lithology and Mineral Resources. 23, 4, pp. 367-374.

BRGM (2017). "Fiche de synthèse sur la criticité des matières premières minérales -Le scandium", novembre 2017.

Duyvesteyn, W.P.C., Putnam, G.F. (2014). Scandium: A review of the element, its characteristics, and current and emerging commercial applications. EMC Metals Corporation, May 2014, 12pp.

European Chemicals Agency (ECHA) (2019). Infocard on Scandium. [online] Available at: <https://echa.europa.eu/substance-information/-/substanceinfo/100.028.299>, accessed 29.1.2020

European Commission (2014). Report on Critical Raw Materials for the EU. Non-Critical Raw Materials Profiles [online] Brussels European Commission, Available at: <https://ec.europa.eu/growth/sectors/raw-materials/specific-interest/critical>

European Commission (2016). DG Trade. Agreements [online] Available at: <http://ec.europa.eu/trade/policy/countries-and-regions/agreements/>

Eurostat (2016a). Annual detailed enterprise statistics for industry (NACE Rev. 2, B-E). [online] Available at: [http://ec.europa.eu/eurostat/en/web/products-datasets/-/SBS\\_NA\\_IND\\_R2](http://ec.europa.eu/eurostat/en/web/products-datasets/-/SBS_NA_IND_R2)

Eurostat (2016b). Statistics on the production of manufactured goods (PRODCOM NACE Rev.2). [online] Available at: <http://ec.europa.eu/eurostat/data/database>

Eurostat (2019). International Trade Easy Comext Database [online] Available at: <http://epp.eurostat.ec.europa.eu/newxtweb/>

Fontboté, Lluís (2019). Scandium recycling from new scrap. Personal communication at the validation workshop. Fontboté, Lluís, University of Geneva, Switzerland.

- Gambogi, G. (2016). Scandium. U.S. Geological Survey, Mineral Commodity Summaries 2016 – Scandium [online] Available at:  
<https://minerals.usgs.gov/minerals/pubs/commodity/scandium/>
- Gambogi, G. (2017). Scandium. U.S. Geological Survey, Mineral Commodity Summaries 2017 – Scandium. [online] Available at:  
<https://minerals.usgs.gov/minerals/pubs/commodity/scandium/mcs-2017-scand.pdf>
- Gambogi, G. (2019). Scandium. U.S. Geological Survey, Mineral Commodity Summaries 2019 – Scandium [online] Available at:  
<https://minerals.usgs.gov/minerals/pubs/commodity/scandium/>, accessed 11.11.2019
- Haley, T.J., Komesu, L., Mavis, N., Cawthorne, J., Upham, H.C. (1962). Pharmacology and toxicology of scandium chloride. *Journal of Pharmaceutical Sciences*. 51 (11): 1043–5. doi:10.1002/jps.2600511107.
- Hocquard C. (2003). Le scandium - Economie et gîtologie, Rapport BRGM, RP-52460-FR. 65 p., 1 Tabl., 2 Fig.
- Hokka, J. & Halkoaho, T. 2016. 3D modelling and mineral resource estimation of the Kiviniemi scandium deposit, Eastern Finland. *Geol. Surv. Finland Rep.* 65/2015. 16 p. Online at:  
[http://tupa.gtk.fi/raportti/arkisto/65\\_2015.pdf](http://tupa.gtk.fi/raportti/arkisto/65_2015.pdf)
- Intermix Met (2016). Products [online] Available at: [www.intermix-met.com/en](http://www.intermix-met.com/en)
- Li, D.Q., Zuo, Y., Meng, S.L. (2004). Separation of thorium(IV) and extracting rare earths from sulfuric and phosphoric acid solutions by solvent extraction method. *J. Alloy. Compd.* 374, pp. 431–433.
- Lipmann A. (2016). Personal communication, December 2016
- Lipmann Walton & Co Ltd. (2016). Minor Metals Trading Company [online] Available at:  
[www.lipmann.co.uk](http://www.lipmann.co.uk)
- Metal Pages (2015). Cancellation of REE export tariffs may increase overseas sales [online] Available at:  
[www.metal-pages.com/news/story/86849/cancellation-of-ree-export-tariffs-may-increase-overseas-sales/](http://www.metal-pages.com/news/story/86849/cancellation-of-ree-export-tariffs-may-increase-overseas-sales/)
- Minerals4EU (2019). European Minerals Yearbook. [online] Available at:  
[http://minerals4eu.brgm-rec.fr/m4eu-yearbook/theme\\_selection.html](http://minerals4eu.brgm-rec.fr/m4eu-yearbook/theme_selection.html)
- OECD (2016). OECD Export restrictions on Industrial Raw Materials database. [online] Available at:  
[http://qdd.oecd.org/subject.aspx?Subject=ExportRestrictions\\_IndustrialRawMaterials](http://qdd.oecd.org/subject.aspx?Subject=ExportRestrictions_IndustrialRawMaterials)
- Rudnick, R.L. and Gao. S. (2003). Composition of the Continental Crust. In: *Treatise on Geochemistry, Volume 3*. Editor: Roberta L. Rudnick. Executive Editors: Heinrich D. Holland and Karl K. Turekian. pp. 659. ISBN 0-08-043751-6. Elsevier, p.1-64.
- UNEP (2011) Recycling Rates of Metals. A Status Report, A Report of the Working Group on the Global Metal Flows to the International Resource Panel. United Nations Environment Programme, [online] Available at: <http://web.unep.org/publications/>
- Wang W., Pranolo Y., Cheng C.Y. (2011) Metallurgical processes for scandium recovery from various resources: A review. *Hydrometallurgy*, Volume 108, pp.1 00–108



World Mining Data (2016) Bundesministerium für Wissenschaft, Forschung und Wirtschaft (Austrian Ministry of Science, Research and Economy) [online] Available at: [www.en.bmfwf.gv.at/Energy/WorldMiningData/Seiten/default.aspx](http://www.en.bmfwf.gv.at/Energy/WorldMiningData/Seiten/default.aspx)

## **22.7.2 Data sources used in the criticality assessment**

Duyvesteyn, W.P.C., Putnam, G.F. (2014). Scandium: A review of the element, its characteristics, and current and emerging commercial applications. EMC Metals Corporation, May 2014, 12pp.

European Commission (2014a). Report on Critical Raw Materials for the EU. [online] Available at: [https://ec.europa.eu/growth/sectors/raw-materials/specific-interest/critical\\_en](https://ec.europa.eu/growth/sectors/raw-materials/specific-interest/critical_en)

European Commission (2014b). Report on Critical Raw Materials for the EU. Non-Critical Raw Materials Profiles [online] Brussels European Commission, Available at: <http://ec.europa.eu/growth/sectors/raw-materials/specific-interest/critical/>

European Commission (2016). DG Trade. Agreements [online] Available at: <http://ec.europa.eu/trade/policy/countries-and-regions/agreements/>

Eurostat (2016a). Annual detailed enterprise statistics for industry (NACE Rev. 2, B-E). [online] Available at: [http://ec.europa.eu/eurostat/en/web/products-datasets/-/SBS\\_NA\\_IND\\_R2](http://ec.europa.eu/eurostat/en/web/products-datasets/-/SBS_NA_IND_R2)

Eurostat (2016b). Statistics on the production of manufactured goods (PRODCOM NACE Rev.2). [online] Available at: <http://ec.europa.eu/eurostat/data/database>

Eurostat (2019). International Trade Easy Comext Database [online] Available at: <http://epp.eurostat.ec.europa.eu/newxtweb/>

Gambogi, G. (2016) Scandium, U.S. Geological Survey, Mineral Commodity Summaries 2016 [online] Available at: <https://minerals.usgs.gov/minerals/pubs/commodity/scandium/>

OECD (2016). OECD Export restrictions on Industrial Raw Materials database. [online] Available at: [http://qdd.oecd.org/subject.aspx?Subject=ExportRestrictions\\_IndustrialRawMaterials](http://qdd.oecd.org/subject.aspx?Subject=ExportRestrictions_IndustrialRawMaterials)

UNEP (2011) Recycling Rates of Metals. A Status Report, A Report of the Working Group on the Global Metal Flows to the International Resource Panel. United Nations Environment Programme, [online] Available at: <http://web.unep.org/publications/>

World Mining Data (2016) Bundesministerium für Wissenschaft, Forschung und Wirtschaft (Austrian Ministry of Science, Research and Economy) [online] Available at: [www.en.bmfwf.gv.at/Energy/WorldMiningData/Seiten/default.aspx](http://www.en.bmfwf.gv.at/Energy/WorldMiningData/Seiten/default.aspx)

## **22.8 Acknowledgments**

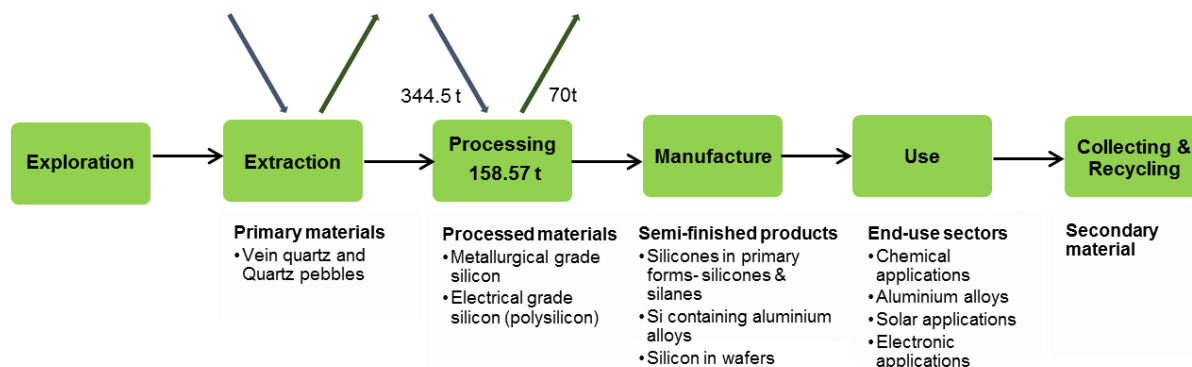
---

This factsheet was prepared by the JRC.

The authors thank the Ad Hoc Working Group on Critical Raw Materials, in particular Corina Hebestreit (Euromines) and Asko Käpyaho (GTK), as well as experts participating in the scandium session of the SCREEN workshop for their valuable contribution and feedback, notably Lluís Fontboté (University of Geneva).

# 23 SILICON METAL

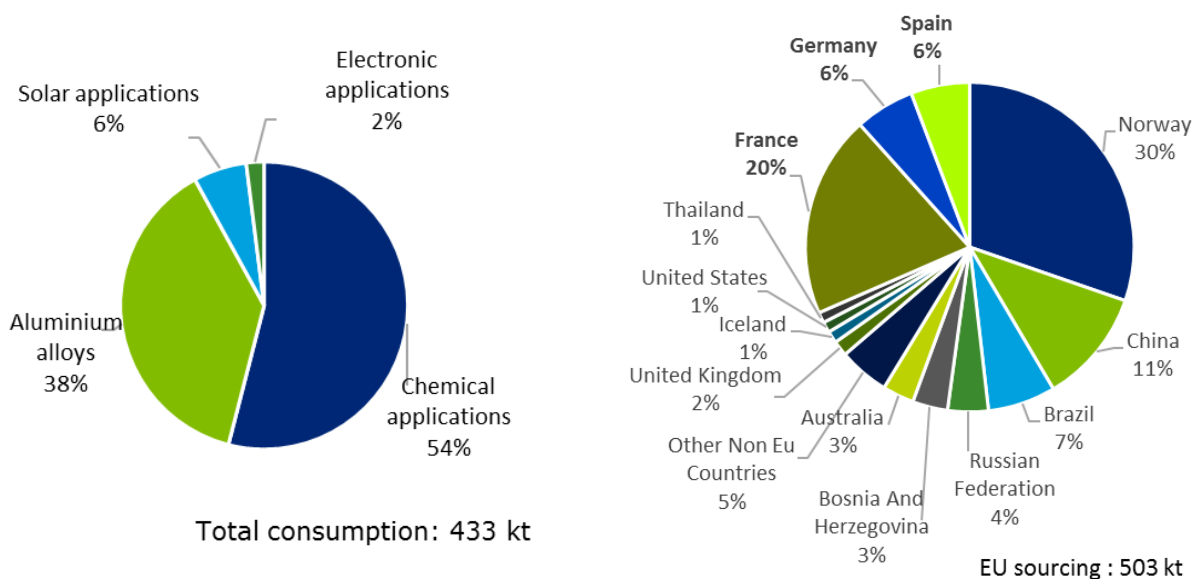
## 23.1 Overview



**Figure 456: Simplified value chain for silicon metal<sup>256</sup>, averaged over 2012-2016**

Silicon metal (chemical symbol Si) is the second most abundant element in the Earth's crust in the form of silicate minerals. It is an inert element extracted from vein quartz and quartz pebbles due to their high silica content. Silicon has no metallic properties but is known as silicon metal in the industry because of its lustrous appearance. There are two grades of silicon metal: metallurgical grade silicon (typically around 99% of Silicon, trade code CN 28046900), representing the majority of the volumes produced, and polysilicon (with a 6N to 11N purity, trade code CN 28046100). Altogether these products are the focus of this assessment. Silicon metal was on the EU's list of CRMs in 2014 and 2017. Unless otherwise specified, all figures in this factsheet are reported in silicon metal content.

<sup>256</sup> Source: JRC elaboration on multiple sources (see next sections).



**Figure 457: End uses of silicon metal in the EU (SCREEN, 2019) and EU sourcing of silicon metal, average 2012-2016<sup>257</sup>**

Global Silicon Metal market size in 2017 was estimated at 6520 Million US\$ in 2017, at a CAGR of 4.4% (Marketwatch, 2019). China remained a leading producer of silicon metal and ferrosilicon. China production accounted for approximately 66% of total global estimated production of silicon materials in 2018 (USGS, 2019). Over the year 2012-2016, the annual EU consumption of silicon metal reached 433 kt per year, which was sourced from import and domestic production. The EU is a net importer of silicon metal with an average import at 344 kt per year over the considered period. The EU imports of silicon metal were mainly from Norway (30%), China (11%) and Brazil (7%). In the EU, silicon metal was produced in France, Germany and Spain, accounting for a total of 158 kt per year in the same period.

The major uses of metallurgical grade silicon are in metallurgy and for the production of silicones and silanes, representing more than 90% of the total world and EU silicon metal consumption. Polysilicon is used as a semiconductor in photovoltaic applications or in microelectronics (Euroalliages, 2016). There are no materials that can replace any of the main uses of metallurgical silicon without serious loss of end performance or increase of cost.

Being silicon solar cells, the most common cells used in commercially available solar panels, silicon metal will significantly contribute to achieving the objectives of the “European strategic long-term vision for a prosperous, modern, competitive and climate neutral economy”<sup>258</sup>. Under this strategy, the transition to clean and renewable electricity is expected to decarbonize also other sectors such as heating, transport and industry. Silicon plays a strategic role in the reduction of CO<sub>2</sub> emissions as component of other green tech applications such as wind turbine generators and as anode component of Li-ion batteries. The contribution of Silicon to the low carbon economy is and will significantly increase as Li-ion batteries are subject of extensive research with the aim of increasing their capacity for electric vehicles (Euroalliages, 2020).

<sup>257</sup> JRC elaboration on silicon metal production figures reported in World Mining Data (2019) and EU-extra EU trade of silicon metal in Eurostat Comext (2019)

<sup>258</sup> COM(2018) 773 final A Clean Planet for all. A European strategic long-term vision for a prosperous, modern, competitive and climate neutral economy

USGS (2019) estimated that the world resources in the producing countries among others, China, United States, Brazil, Norway, are sufficient to supply world demand of silicon metal for many decades. There are no quantitative estimates of reserves of silicon metal worldwide.

The quantity of world annual production of silicon metal during the year 2012-2016 was 2,541 kt per year. China dominated the production with 66% of share, followed by United States (8%), Brazil (7%), and Norway (6%) (World Mining Data, 2019). The EU production of silicon metal occurred in France, Germany, and Spain, each with 6% of share in global supply over the same period (World Mining Data, 2019).

The End-of-Life Recycling Input Rate (EoL-RIR) for silicon metal is estimated to continue to be low (0%) despite the development of several recycling plants in place in Europe. Most chemical applications of silicon metal are dispersive, thus not allowing for any recovery. There is no functional recycling of silicon metal in aluminium alloys.

The production of silicon metal is energy intensive, therefore the energy cost is a major production cost element. In Europe, silicon production is subject to the European Directive on the Emissions Trading Scheme<sup>259</sup> which entails direct and indirect carbon costs.

The United States, the EU, and Canada have been imposing anti-dumping duties on silicon metal from China, the current biggest producer of silicon metal (Monnet, 2019).

## **23.2 Market analysis, trade and prices**

---

### **23.2.1 Global market analysis and outlook**

China remained the biggest producer of silicon metal over the year 2012-2016. China will continue to increase its market share among global producers until 2025, following the same trend observed in the past years. This trend may be explained by production costs in China remaining at the lowest level globally speaking as well as by the Chinese production overcapacity (Euroalliages, 2016). The United States, the EU, and Canada have been imposing anti-dumping duties on silicon metal from China, the biggest producer of silicon metal (Monnet, 2019).

Growth in the silicon metal market is expected to continue in the coming years. Consumption for silicon metal comes primarily from the aluminium and chemical industries. Ferroglobe estimated world silicon metal consumption to be divided between the silicone (50%), aluminium (40%), and solar (10%) markets (Monnet, 2018).

Solar PV cells are predicted to become a crucial part of the overall energy mix between 2013 and 2050 to meet low carbon future (World Bank, 2017). Global PV electricity production is projected to rapidly increase and many studies assume that the majority of future solar PV installations will be of the crystalline silicon variety. (Euroalliages, 2019).

Global consumption of polycrystalline silicon for solar-grade and semiconductors was forecast to increase by a compound average growth rate of 10.2% from 2016 to 2025 (USGS, 2016b)

The estimations for the outlook for supply and demand of silicon metal are shown in Table 188, provided by industry experts.

---

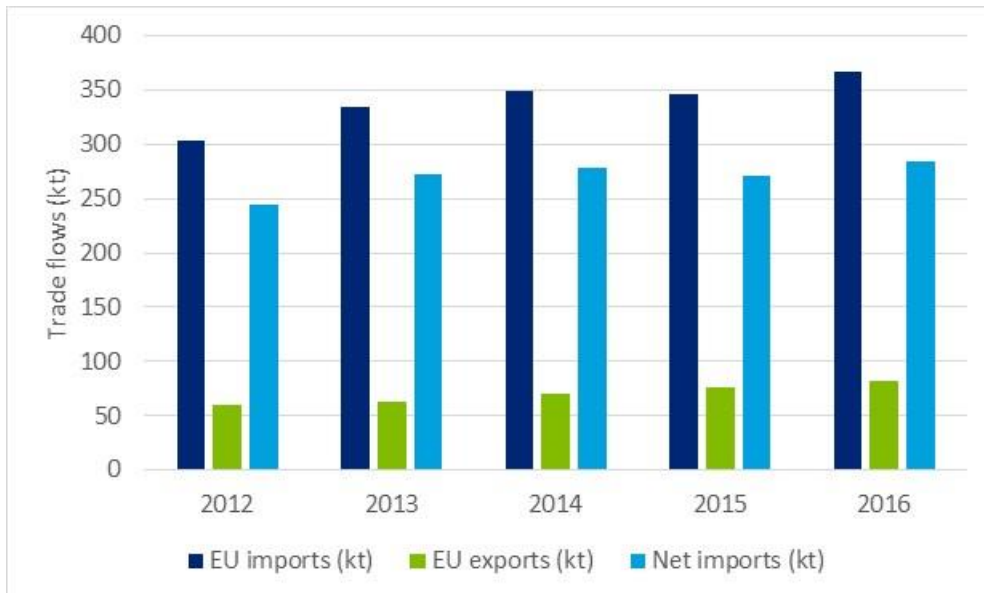
<sup>259</sup> Directive 2003/87/EC of the European Parliament and of the Council of 13 October 2003 establishing a scheme for greenhouse gas emission allowance trading within the Community and amending Council Directive 96/61/EC

**Table 188: Qualitative forecast of supply and demand of silicon metal (source: European Commission, 2017)**

Materials	Criticality of the material in 2020		Demand forecast			Supply forecast		
	Yes	No	5 years	10 years	20 years	5 years	10 years	20 years
Silicon metal	X		+	+	+	+	+	+

### 23.2.2 EU trade

The EU is a net importer of silicon metal with an average annual net import figure in the period 2012-2016 of 344kt per year. There has been an increasing trend of EU import of silicon metal between the years 2012-2016 (Figure 458).

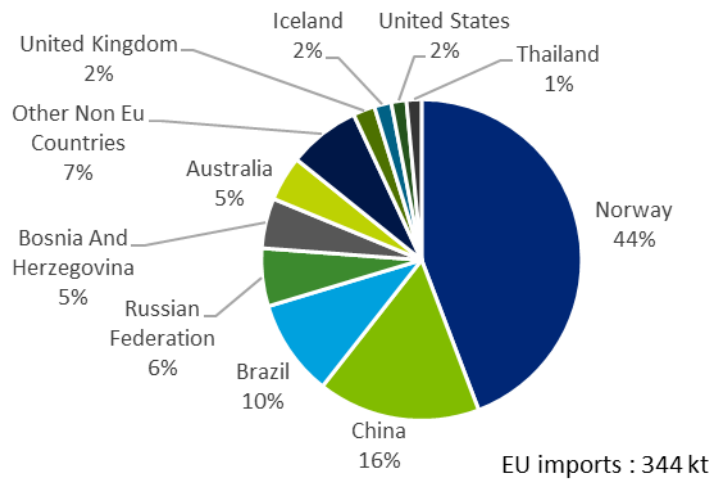


**Figure 458: EU trade flows for silicon metal. Data from Eurostat, 2012-2016 (Eurostat, 2019a)**

Approximately 68% of the EU apparent consumption of silicon metal was supplied from outside EU. The main suppliers of the EU are Norway, China, and Brazil which represent 44%, 16% and 10% of the total EU imports respectively (Figure 459) – although these shares are evolving along the years.

There is no restriction on commercial trade of silicon metal (i.e. no export tax, export quota or export prohibition of silicon metal from extra-EU countries) with the EU Member States. However, China applied a 15% export tax on all exports of silicon metal, re-establishing de facto some level playing field with the EU according to several industrial players, which was removed in 2013 (OECD, 2016; Euroalliages, 2016).

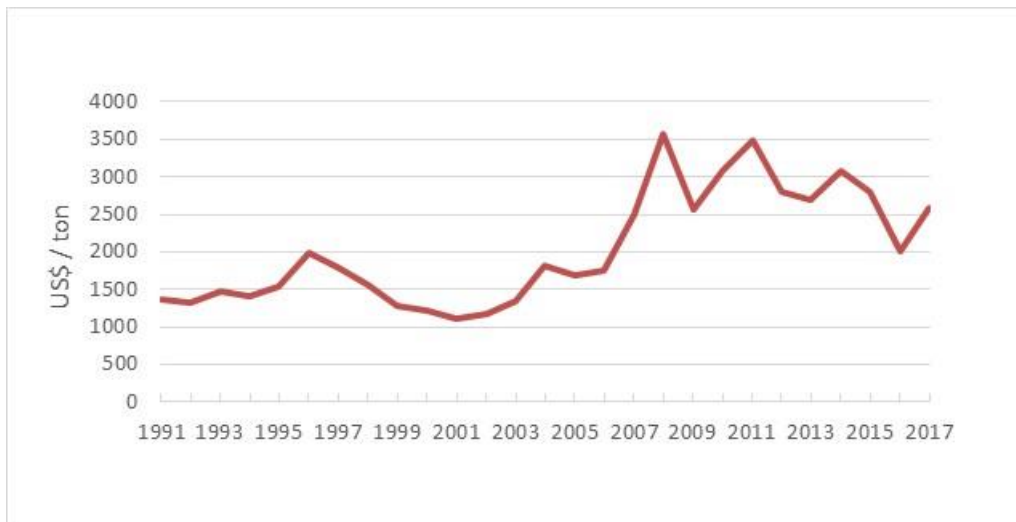
Some free trade agreements exist with major EU suppliers: Norway and Bosnia Herzegovina (European Commission, 2016).



**Figure 459: EU imports of silicon metal, annual average for the year 2012-2016. Data from Eurostat. (Eurostat, 2019a)**

### 23.2.3 Prices and price volatility

Silicon metal prices trend is shown in Figure 460. Silicon metal prices increased slowly between 2002 and late 2007 and reached the peak around spring 2008. The economic recession in 2008 and 2009 resulted in prices decreasing sharply back to 2007 levels. Another pike in silicon prices was experienced in 2011. Spot prices of silicon have dropped between 2013 and 2015, due to a flat demand and a steady draw-down of silicon inventories outside China in 2014-2015 (CRU, 2015). In 2016, the price of silicon metal dropped again at USD 2006 per tonne. The oversupply in the market combined with decreased steel production and weak aluminium alloy demand contributed to decreased silicon prices in 2015-2016 (USGS, 2017).



**Figure 460: Prices of metallurgical grade silicon metal (USD per tonne) from 1991 to 2017. Data from DERA mineral price monitor (DERA, 2019)**

## 23.3 EU demand

---

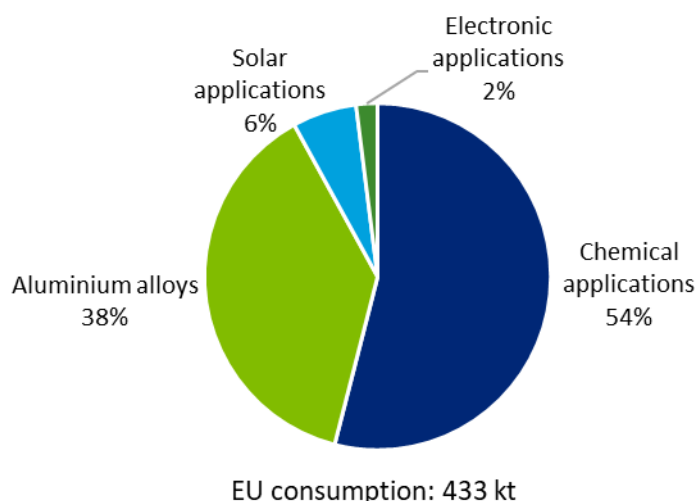
### 23.3.1 EU demand and consumption

The annual European consumption of silicon metal totalled around 433 kt in over the period 2012-2016. Approximately 68% of the EU consumption of silicon metal came from import activity with non-EU countries (Eurostat, 2019). The main suppliers to the EU are Norway (44%), China (17%) and Brazil (10%) and The EU domestic production of silicon metal represented 32% of the total quantity consumed in the EU.

### 23.3.2 Uses and end-uses of silicon metal in the EU

The major uses of silicon in the EU remained the same as in 2010-2014 (Figure 461). The main uses of silicon metal are in the aluminium and chemical industries (European Commission, 2014). In addition, silicon metal is a strategic raw material used in the renewable energy (photovoltaic industry) and in electronic devices.

- **Chemical industry:** Silicon metal is used to produce silicones, synthetic silica and silanes. Silicone products such as surfactants, lubricant, sealants and adhesives are used in various sectors including construction (e.g. in insulating rubbers), industrial processes (e.g. as antifoam agent in the oil and gas industry), as well as personal care (e.g. cosmetics) and transport (CES, 2016). Silanes are used in the glass, ceramic, foundry and painting industries (European Commission, 2014; Euroalliances, 2016).
- **Aluminium alloys:** Silicon is dissolved in molten aluminium to improve the viscosity of the liquid aluminium and to improve the mechanical properties of aluminium alloys. There are two important groups of aluminium alloys which contain silicon as a main element: casting alloys and wrought alloys. In the former the silicon content is 7% to 12%; wrought alloys contain magnesium and silicon, where the silicon content is between 0.5% and 1%. The primary use is in castings in the automotive industry due to improved casting characteristics described above and the reduced weight of the components (European Commission, 2014; Euroalliances, 2016).
- **Solar cells:** Ultrahigh-purity grades silicon is used for the production of solar panels. Silicon solar cells are the most common cells used in commercially available solar panels. Crystalline silicon PV cells have laboratory energy conversion efficiencies as high as 25% for single-crystal cells and 20.4% for multicrystalline cells. However, industrially produced solar modules currently achieve efficiencies ranging from 18%–24%. Solar cell prices dropped significantly in 2011, partly due to polysilicon selling price decrease resulting from over production (European Commission, 2014; Euroalliances, 2016).
- **Electronics:** Ultra-high purity grade silicon is used extensively in electronic devices such as silicon semiconductors, transistors, printed circuit boards and integrated circuits. Semiconductor-grade silicon metal used in making computer chips is crucial to modern technology (European Commission, 2014; Euroalliances, 2016).
- **Other applications of silicon metal include explosives, refractories and ceramics.**



**Figure 461: EU end uses of silicon metal (SCREEN, 2019). Annual average figures for 2012-2016<sup>260</sup>.**

Table 189 presents the main uses of silicon metal in the EU. Relevant industry sectors are described using the NACE sector codes (Eurostat, 2019b).

**Table 189: Silicon metal applications, 2-digit and associated 4-digit NACE sectors, and value added per sector. [Data from the Eurostat database, (Eurostat, 2019b)]**

Applications	2-digit NACE sector	4-digit NACE sectors	Value added of NACE 2 sector (millions €)
Chemical applications	C20 - Manufacture of chemicals and chemical products	C2016 - Manufacture of plastics in primary forms; C2017 - Manufacture of synthetic rubber in primary forms; C2030 - Manufacture of paints, varnishes and similar coatings, printing ink and mastics; C2041 - Manufacture of soap and detergents, cleaning and polishing preparations	105,514
Aluminium alloys	C24 - Manufacture of basic metals	C2442 - Aluminium production	55,426
Solar applications	C26 - Manufacture of computer, electronic and optical products	C2611 - Manufacture of electronic components	65,703
Electronic applications	C26 - Manufacture of computer, electronic and optical products	C2611 - Manufacture of electronic components	65,703

<sup>260</sup> Apparent consumption figures for silicon metal is derived from adding EU production (based on the figures reported by British Geological Survey, 2019) and imports and subtracting exports (imports and exports figures are based on the information reported by Eurostat-Comext, 2019)



### 23.3.3 Substitution

Substitutes are identified for the applications and end uses of the commodity of interest. In the case of silicon metal, there are no materials that can replace any of the main uses of metallurgical silicon without serious loss of end performance or increase of cost.

In chemical application, there is no material for replacement of silicon in silicones and silanes, or in end-use products based on these chemicals. In comparison, materials such as thermoplastics or rubber are not as durable and heat resistant as silicones. Therefore, the use of silicones vs. substitutes depends on the expected properties of the final product; this characteristic is already accounted for when selecting the most appropriate material. No viable current substitute is currently considered (CES, 2016).

In manufacturing of aluminium, silicon is used to lower the melting point in aluminium manufacturing and to increase strength, machineability and corrosion resistance in aluminium products. There is currently no substitute to silicon metal for this application (Tercero, 2018).

In solar application, replacement technologies to silicon-based technology for solar applications exist (however this is not material to material substitution but rather equivalent technology), with reduced performance. An example is, CIGS technology, which is up to twice more expensive than silicon-based technology. It is estimated that Si technology represent 92% of the EU market; the rest is shared between CdTe and CIGS technologies. New hybrid technologies are currently being developed, but not on the market yet.

In the micro-electronics industry, GaAs is a substitute for silicon but with lower performance and is not used for mainstream applications. Germanium may be used as well in combination to silicon (i.e. silicon remains as physical support/monocrystalline, Ge on the top of layer). R&D on replacement technologies concerns graphic layers, carbon nanotubes (Wacker, 2016).

## 23.4 Supply

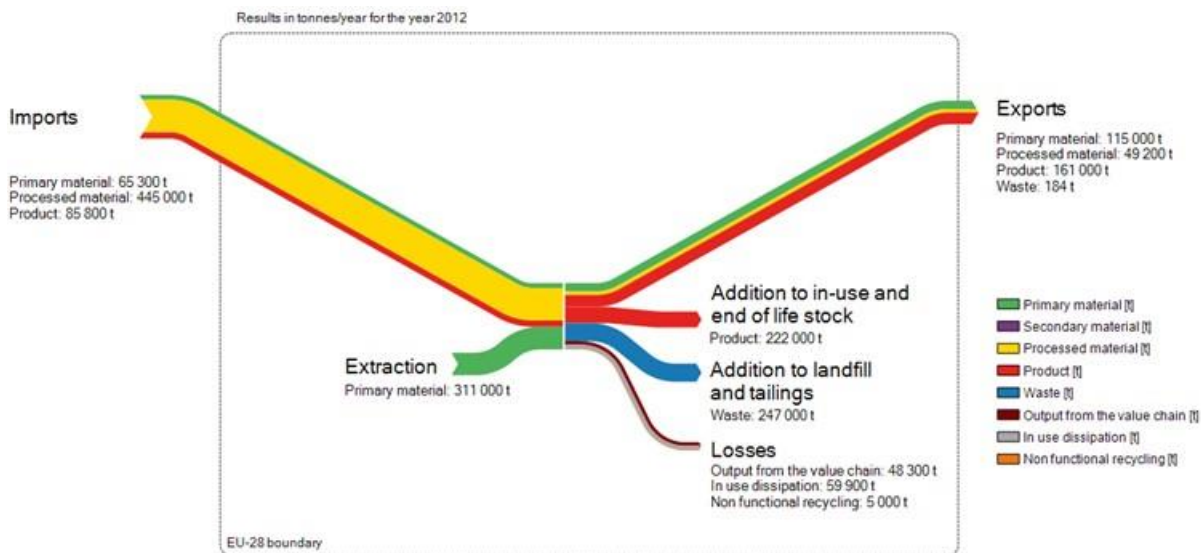
---

### 23.4.1 EU supply chain

The EU supply chain of silicon metal can be described by the following key points:

- Quartz mines and resources in the EU were reported by Lauri, L. et. al, (2018). However, it is not clear if any of these has high-purity quartz necessary for silicon metal production. High purity quartz is extracted in three EU Member States and processed into silicon metal – namely France, Spain and Germany. There is no precise data on high purity quartz extraction, at EU level or at global level. The majority of high purity quartz is directly turned into silicon metal onsite (Bio Intelligence Service, 2015).
- The 5-year average EU production of silicon metal between 2012 and 2016 was 158 kt per year, which accounts for 8% of the global production. Producing EU countries are France, Spain and Germany (WMD, 2019).
- The traded quantities of silicon metal show that the EU is a net importer of silicon metal. Domestic production of silicon cannot satisfy the EU demand. Norway is the main country supplying silicon metal to the EU due to its geographical proximity, and accounts for 44% of total imports over the year 2012-2016 (Eurostat, 2019a).
- Europe imports silicon in the forms of silicon metal as well as intermediate products such as silicon-based chemicals and silicon wafers.
- The import reliance for silicon metal in the EU is estimated at 63%, which is not an unexpected figure considering the relatively small EU production, high import and low exports figures.

- An end-of-life recycling plant for PV waste exists in France. In 2017, Rousset in Bouches-du-Rhône, Veolia, PV CYCLE and the Syndicat des Énergies Renouvelables opened the first line in France and in Europe dedicated to recycling end-of-life photovoltaic panels. The plant was planned to process 1,800 tonnes of material in 2017 year year that will gradually increase to 4,000 tonnes by 2021 (Veolia, 2018).



**Figure 462: Material system analysis of silicon metal, reference year 2012 (simplified for EU-27 and the UK)(BioIntelligence Service, 2015)**

The flows of silicon metal through the EU economy are demonstrated in Figure 462.

## 23.4.2 Supply from primary materials

### 23.4.2.1 Geology, resources and reserves of silicon metal

#### Geological occurrence:

Quartz makes up approximately 12% by weight of the lithosphere, making it the second most common mineral in the Earth's crust. SiO<sub>2</sub> accounts for 66.62% of the mass of the upper crust (Rudnick, 2003). Quartz is found in magmatic, metamorphic and sedimentary rocks and may be distinguished between numerous quartz types, depending on its genesis and specific properties.

Quartz occurs in many different settings throughout the geological record; however, only very few deposits are suitable in volume, quality and amenability to tailored refining methods for speciality high purity applications, which require extreme qualities, with specific low-ppm or sub-ppm requirements for maximum concentrations of certain trace metals (European Commission, 2014).

Magmatic SiO<sub>2</sub> rocks represent more than 90% of quartz and other SiO<sub>2</sub> minerals of the lithosphere, however this share is not representative of the materials used to process silicon metal. The majority of quartz in SiO<sub>2</sub>-rich igneous and volcanic rocks (granite, rhyolite) is intergrown with other rock-forming silicates. Therefore, quartz from these rocks does not play an important role as raw material. In contrast, pegmatite bodies and hydrothermal veins Quartz makes up approximately 12% by weight of the lithosphere, making it the second most common mineral in the Earth's crust. SiO<sub>2</sub> accounts for 66.62% of the mass of the upper crust (Rudnick,

2003). Quartz is found in magmatic, metamorphic and sedimentary rocks – and may be distinguished between numerous quartz types, depending on its genesis and specific properties.

Quartz from metamorphic rocks represents only about 3% of the whole quartz in the lithosphere (Rösler, 1981) and are not usable as high-quality SiO<sub>2</sub> raw material. However, metamorphic quartzites of high chemical purity (98% SiO<sub>2</sub>) can sometimes be used as raw materials for high-technology industries. Moreover, metamorphogenic quartz mobilisates often represent a high-purity SiO<sub>2</sub> material that can be used e.g. as raw material for single-crystal growth (Haus, 2012).

Finally, sedimentary SiO<sub>2</sub> rocks represent the majority of the high-purity quartz volumes supplied to the industry worldwide. However, quartz in sedimentary rocks (mostly under the form of quartz sands, quartz gravel or sedimentary quartzite) is used in silica sands or ferrosilicon value chains, but its purity does not rank high enough for any use as silicon metal (Haus, 2012).

### **Global resources and reserves of high purity quartz<sup>261</sup>:**

Information on high purity quartz from the Minerals4EU platform (2014) is available in the silica sands factsheet, but is not displayed here as only a small – and unknown – share or it is part of the silicon metal value chain.

It is acknowledged that reserves of high purity quartz are large enough to meet the worldwide consumption needs for the next decades.

### **EU resources and reserves<sup>262</sup>:**

In the EU, a number of quartz mines and resources have been reported. However, it is not clear if any of these has high-purity quartz necessary for silicon metal production. In Austria, Bulgaria, Greece, and Italy, some deposits were identified with no information on their resource. In Austria and Portugal, there were some deposits and production of quartz in the past. In Finland, there are two active quartz mines with a production quantity of 93 kt of quartz in 2016, some of which may be categorised to medium to high-purity quartz. There are 52 quartz deposits in Sweden, including three active mines producing 100 kt of quartz per year used in the ferro-alloy industry.

---

<sup>261</sup> There is no single source of comprehensive evaluations for resources and reserves that apply the same criteria to deposits of silicon metal in different geographic areas of the EU or globally. The USGS collects information about the quantity and quality of mineral resources but does not directly measure reserves, and companies or governments do not directly report reserves to the USGS. Individual companies may publish regular mineral resource and reserve reports, but reporting is done using a variety of systems of reporting depending on the location of their operation, their corporate identity and stock market requirements. Translations between national reporting codes are possible by application of the CRIRSCO template, which is also consistent with the United Nations Framework Classification (UNFC) system. However, reserve and resource data are changing continuously as exploration and mining proceed and are thus influenced by market conditions and should be followed continuously.

<sup>262</sup> For Europe, there is no complete and harmonised dataset that presents total EU resource and reserve estimates for silicon metal. The Minerals4EU project is the only EU-level repository of some mineral resource and reserve data for silicon metal, but this information does not provide a complete picture for Europe. It includes estimates based on a variety of reporting codes used by different countries, and different types of non-comparable datasets (e.g. historic estimates, inferred reserves figures only, etc.). In addition, translations of Minerals4EU data by application of the CRIRSCO template is not always possible, meaning that not all resource and reserve data for silicon metal the national/regional level is consistent with the United Nations Framework Classification (UNFC) system (Minerals4EU 2019). Many documented resources in Europe are based on historic estimates and are of little current economic interest. Data for these may not always be presentable in accordance with the UNFC system. However, a very solid estimation can be done by experts.

There are also known unexploited occurrences in Sweden, containing medium to high quality quartz (Lauri, L. et. al., 2018).

#### **23.4.2.2 Mining of high purity quartz and processing of silicon metal**

Quartz extraction occurs by drilling and blasting operations from veins deposits (vein quartz) as well as from fluvial deposits (quartz pebbles), by simple excavation methods. The major deposits of high purity quartz currently mined for silicon metal processing are located in Turkey, Egypt and Spain, among others (Euroalliances, 2016). Others include the USA, Norway and Russia. High purity quartz for the silicon metal industry is extracted as main product; most of the quartz processed in the EU into silicon originates from European countries, namely Spain and France (BGS, 2016). There is no reliable worldwide data.

Once mined, quartz is reduced to silicon metal by carbothermic reduction. This takes place in a submerged electric arc furnace containing quartz and carbon materials, such as coke and charcoal. Electric energy is supplied by electrodes submerged in the charge – with temperatures from 800 to 1,300°C at the top of the furnace, and exceeding 2,000°C at the bottom, near the electrodes (Aasly, 2008). Molten silicon metal is produced at the bottom of the furnace. The silicon produced has a purity of approximately 98.5%; the main impurities are iron, aluminium and calcium. Most silicon applications require further refining to reach 99% purity; this is done by treating the molten silica with oxidative gas and slag forming additives. Silicon of this purity is known as metallurgical grade silicon and is used in the aluminium, chemical and polysilicon industries. Semiconductor and solar grade silicon (polysilicon) must be of ultra-high purity (between 6N and 11N) to ensure semiconducting properties; this is commonly done through the Siemens process (European Commission, 2014). In this process, the metallurgical grade silicon is converted to a volatile compound that is condensed and refined by fractional distillation. Ultra-pure silicon is then extracted from this refined product.

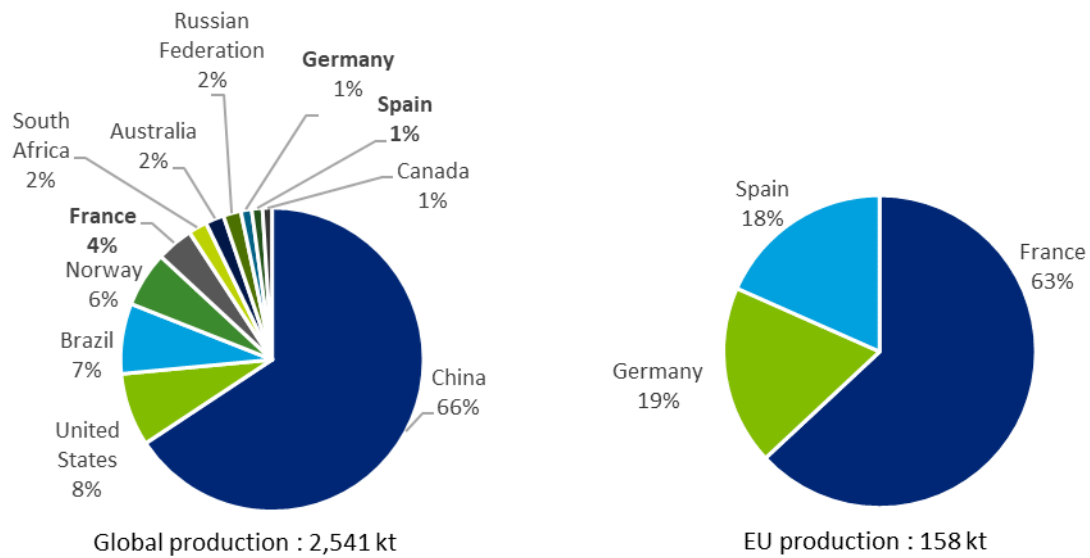
The quartz raw material follows specific requirements from the industry to be used in silicon metal processing, among which: chemistry (specifications on impurities), lump size; as well as mechanical and thermal strength, and softening properties. These characteristics may influence the process itself or the purity of the silicon metal processed (Aasly, 2008).

The processing of silicon also generates silica fumes which have been successfully transformed by the silicon (and ferro-silicon) industry from waste to a by-product.

#### **23.4.2.3 World and EU production of silicon metal**

Production share of refined silicon metal by country (average 2012-2016) is presented in Figure 463. The production in this period reached an average of 2,541 kt per year. Global supply of silicon metal is dominated by China with about 1,669 kt per year equivalent to 66% of the global annual production over the years 2012-2016. United States and Brazil were the second and third largest producing countries, each accounting for 198 kt per year (8% of global supply) and 190 kt per year (7% of global supply).

The overcapacity built in China in the past decades is equivalent to more than twice the world consumption (2,9 million tonnes) in 2019 (Euroalliances, 2020). Chinese production capacity of silicon metal increased from 4 million tonnes in 2014 to 6-7 million tonnes in 2019. This expansion of more than 2 million tonnes is concentrated in the Xinjiang province. This region is able on its own to almost supply the worldwide consumption of silicon. It is important to note that almost 100% of power generation in this region is coal based.



**Figure 463: Global (left) and EU (right) refined production of silicon metal, average 2012–2016 (Data from BGS, 2019)**

### 23.4.3 Supply from secondary materials/recycling

Most chemical applications of silicon metal are dispersive, thus not allowing for any recovery. In recent years there have been functional recycling plants of Si scrap from wafers and from photovoltaic panels, such as:

- Resitec in Norway that recycles wafers generated in the production of photovoltaic materials (PV). ReSiTec produces more than 500 tons of recycled, high-purity silicon metal powder per year (Moen, et. al., 2017)
- The recycling plant Veolia in France that treat end-of-life solar panel

Silicon metal used in the electronic industry is of higher quality than for other applications. Most of the silicon scrap generated during crystal ingot and wafer production for electronic applications can therefore be used in the photovoltaic industry (Woditsch and Koch, 2002).

There is no functional recycling of silicon metal in aluminium alloys.

In the industry buying metallurgical grade silicon, for economic and environmental reasons, recycling streams exist as well as separate or specialised processes for utilisation of any side streams. However, very little material is sold back into the market by metallurgical silicon users (Euroalliages, 2016).

Although there were new functional recycling plants for silicon metal, it has not been possible to quantify the precise updated end of life recycling input rate for silicon metal. The recycling input rate, was estimated to remain low. According to the MSA study of silicon metal, the end of life recycling input rate for silicon metal is 0% (Bio Intelligence Service, 2015). This value was used for the calculation of criticality.

**Table 190: Material flows relevant to the EOL-RIR of silicon metal<sup>263</sup>**

MSA Flow	Value (t)
B.1.1 Production of primary material as main product in EU sent to processing in EU	180,719
B.1.2 Production of primary material as by product in EU sent to processing in EU	0
C.1.3 Imports to EU of primary material	65,254
C.1.4 Imports to EU of secondary material	0
D.1.3 Imports to EU of processed material	444,806
E.1.6 Products at end of life in EU collected for treatment	206,619
F.1.1 Exports from EU of manufactured products at end-of-life	183
F.1.2 Imports to EU of manufactured products at end-of-life	0
G.1.1 Production of secondary material from post consumer functional recycling in EU sent to processing in EU	0
G.1.2 Production of secondary material from post consumer functional recycling in EU sent to manufacture in EU	0

## 23.5 Other considerations

### 23.5.1 Environmental and health and safety issues

The production of silicon metal is energy intensive, therefore the energy cost is a major production cost element. The energy source used by the major silicon producing country, China, is coal. According to Euroalliages, Chinese producers also benefit from lower power tariffs (European Commission, 2017). On the contrary, most silicon metal plants in Europe are historically located close to hydropower sources. A new silicon metal plant based on exclusively renewable energy was going to be scheduled in Iceland in 2018. The plant would process raw material from quarry in Poland.

In Europe, silicon production is subject to the European Directive on the Emissions Trading Scheme (2003/87/EC) which entails direct and indirect carbon costs. Today there is no global level playing field when it comes to climate requirements (Euroalliages, 2016). Silicon is not hazard classified.

### 23.5.2 Socio-economic issues

No specific issues were identified during data collection and stakeholders consultation.

## 23.6 Comparison with previous EU assessments

The assessment has been conducted using the same methodology as for the 2017 list. The results of this and earlier assessments are shown in Table 191.

**Table 191: Economic importance and supply risk results for silicon metal in the assessments of 2011, 2014, 2017, 2020 (European Commission, 2011-2014-2017)**

Assessment	2011		2014		2017		2020	
	EI	SR	EI	SR	EI	SR	EI	SR
Silicon metal	-	-	7.13	1.63	3.8	1.0	4.2	1.18

<sup>263</sup> EOL-RIR=(G.1.1+G.1.2)/(B.1.1+B.1.2+C.1.3+D.1.3+C.1.4+G.1.1+G.1.2)

The economic importance of silicon metal has slightly increased in comparison to the economic importance value in criticality assessment 2017. The increasing value is caused by the change in value added in the sectors to which the economic importance of silicon metal was assigned.

The supply risk of silicon metal showed a higher score in comparison to the result in criticality assessment 2017. This change can be explained by the increase of the production from China over the period 2012-2016, making the global supply more concentrated. Moreover, there was a decreasing EU domestic production of silicon metal during the same period.

## **23.7 Data sources**

---

The trade data of silicon metal in this assessment included codes 28046100 'Silicon containing  $\geq 99.99\%$  by weight of silicon' and 28046900 'Silicon containing  $< 99.99\%$  by weight of silicon'. These data were averaged over the five-year period 2012 to 2016.

End-use application shares figure for silicon metal in the EU is based on the criticality assessment 2017. Their validity was verified by industry experts (Euroalliages, 2019). Production data for silicon metal are from BGS World Mineral Statistics dataset. Trade data were extracted from the Eurostat Easy Comext database (Eurostat, 2019). Data on trade agreements are taken from the DG Trade webpages (European Commission, 2019). Information on export restrictions are derived from the OECD Export restrictions on the Industrial Raw Materials database (OECD, 2019).

### **23.7.1 Data sources used in the factsheet**

Aasly (2008). Properties and behaviour of quartz for the silicon process. PhD thesis. NTNU University

BGS (2019). European Mineral Statistics. [online] Available at: <https://www.bgs.ac.uk/mineralsuk/statistics/europeanStatistics.html>

BGS (2016). World Mineral Production 2010-2014 [online]. Keyworth, Nottingham British Geological Survey, Available at: <http://www.bgs.ac.uk/mineralsuk/statistics/home.html>

Bio Intelligence Service (2015). Study on Data for a Raw Material System Analysis: Roadmap and Test of the Fully Operational MSA for Raw Materials – Final Report. Prepared for the European Commission, DG GROW.

CES (2016). The socioeconomic Impact of the silicones industry in Europe. [online] Available at: [http://www.silicones.eu/uploads/Modules/Faq/ces\\_socio-economic\\_study\\_eu\\_final.pdf](http://www.silicones.eu/uploads/Modules/Faq/ces_socio-economic_study_eu_final.pdf)

CRU (2015). Why have silicon prices fallen so sharply? [online] Available at: <http://www.crugroup.com/about-cru/cruinsight/137461>

DERA (2019). Price Monitor. Available at: [https://www.deutsche-rohstoffagentur.de/SharedDocs/GT\\_Produkte/Mineral\\_Rohstoffe/volatilitaetsmonitor\\_allergenTab\\_DE.html?nn=5091242](https://www.deutsche-rohstoffagentur.de/SharedDocs/GT_Produkte/Mineral_Rohstoffe/volatilitaetsmonitor_allergenTab_DE.html?nn=5091242)

Euroalliages (2016). Communication during CRM review process

Euroalliages (2019). Communication during CRM review process

Euroalliages (2020). Communication during CRM review process

- European Commission (2011). Critical raw materials for the EU. [online] Available at: [https://ec.europa.eu/growth/sectors/raw-materials/specific-interest/critical\\_en](https://ec.europa.eu/growth/sectors/raw-materials/specific-interest/critical_en)
- European Commission (2014). Report on Critical Raw Materials for the EU. [online] Available at: [https://ec.europa.eu/growth/sectors/raw-materials/specific-interest/critical\\_en](https://ec.europa.eu/growth/sectors/raw-materials/specific-interest/critical_en)
- European Commission (2017). Report on Critical Raw Materials for the EU. [online] Available at: [https://ec.europa.eu/growth/sectors/raw-materials/specific-interest/critical\\_en](https://ec.europa.eu/growth/sectors/raw-materials/specific-interest/critical_en)
- European Commission (2016). DG Trade. Agreements [online] Available at: <http://ec.europa.eu/trade/policy/countries-and-regions/agreements/>
- Eurostat (2019a). International Trade Easy Comext Database [online] Available at: <http://epp.eurostat.ec.europa.eu/newxtweb/>
- Eurostat (2019b). Annual detailed enterprise statistics for industry (NACE Rev. 2, B-E). [online] Available at: [http://ec.europa.eu/eurostat/en/web/products-datasets/-/SBS\\_NA\\_IND\\_R2](http://ec.europa.eu/eurostat/en/web/products-datasets/-/SBS_NA_IND_R2)
- Haus, R (2012). Chapter 2: Assessment of high purity quartz resources. In: J. Götze and R. Möckel (eds.), Quartz: Deposits, Mineralogy and Analytics, Springer Geology, DOI: 10.1007/978-3-642-22161-3\_2.
- Dr. Laura LAURI (GTK), Teresa Brown, Gus Gunn (BGS), Per Kalvig (GEUS), Henrike Sievers (BGR). (2018). SCRREEN D3.1. Identification and quantification of primary CRM resources in Europe.
- Marketwatch (2019). Global Silicon Metal Market 2019 Market Size, Share, Trends, Growth, CAGR Status and Key Players Forecast to 2025 Press release published: Oct 2, 2019. Available online at: <https://www.marketwatch.com/press-release/global-silicon-metal-market-2019-market-size-share-trends-growth-cagr-status-and-key-players-forecast-to-2025-2019-10-02>
- Minerals4EU (2019). European Minerals Yearbook. [online] Available at: [http://minerals4eu.brgm-rec.fr/m4eu-yearbook/theme\\_selection.html](http://minerals4eu.brgm-rec.fr/m4eu-yearbook/theme_selection.html)
- Moen, Monica, Terje Halvorsen, Knut Mørk, and Sjur Velken. 2017. "Recycling of Silicon Metal Powder from Industrial Powder Waste Streams." Metal Powder Report 72(3): 182–87. <http://dx.doi.org/10.1016/j.mprp.2016.04.005>.)
- Monnet, A. (2019). Contribution after Criticality Validation workshop, Brussels, 10 September 2019.
- Monnet, A., Abderrahim, A.A. (2018). Report on major trends affecting future demand for critical raw materials. SCRREEN D2.2. Available online at: <http://www.screen.eu/wp-content/uploads/2018/07/D2.2-Report-on-major-trends-affecting-future-demand-for-critical-raw-materials.pdf>
- OECD (2019). Export restrictions on Industrial Raw Materials database. [online] Available at: [http://qdd.oecd.org/subject.aspx?Subject=ExportRestrictions\\_IndustrialRawMaterials](http://qdd.oecd.org/subject.aspx?Subject=ExportRestrictions_IndustrialRawMaterials)
- Rösler, HJ (1981). Lehrbuch der Mineralogie. VEB Deutscher Verlag für Grundstoffindustrie, Leipzig, 1981, Leinen
- Rudnick, R.L. and Gao. S. (2003). Composition of the Continental Crust. In: Treatise on Geochemistry, Volume 3. Editor: Roberta L. Rudnick. Executive Editors: Heinrich D. Holland and Karl K. Turekian. pp. 659. ISBN 0-08-043751-6. Elsevier, p.1-64



SCRREEN workshop. (2019). "Validation Workshop on Critical Raw Materials, 10-12 September 2019, Thon Hotel Brussels City Centre."

Tercero, Luis (2018). CRM Profiles. Available online at <http://screen.eu/wp-content/uploads/2018/05/SCRREEN-D5.1-CRM-profiles.pdf>

USGS. (2016). Silicon - Mineral Commodity Summaries. United States Geological Survey. Ed., Washington DC, pp.2 Available at: <https://prd-wret.s3-us-west-2.amazonaws.com/assets/palladium/production/atoms/files/mcs-2016-simet.pdf>

USGS. (2017). Silicon - Mineral Commodity Summaries. United States Geological Survey. Ed., Washington DC, pp.2 Available at: <https://prd-wret.s3-us-west-2.amazonaws.com/assets/palladium/production/atoms/files/mcs-2017-simet.pdf>

USGS. (2019). Silicon - Mineral Commodity Summaries. United States Geological Survey. Ed., Washington DC, pp.2 Available at: <https://prd-wret.s3-us-west-2.amazonaws.com/assets/palladium/production/atoms/files/mcs-2019-simet.pdf>

Veolia. 2018. "Veolia Opens the First European Plant Entirely Dedicated to Recycling Photovoltaic Panels." <https://www.veolia.com/en/newsroom/news/recycling-photovoltaic-panels-circular-economy-france> (January 13, 2020). Wacker (2016). Communication during the review

Woditsch P & Koch W (2002). Solar grade silicon feedstock supply for PV industry, Solar Energy Materials & Solar Cells; 72, 11-26  
<http://wenku.baidu.com/view/3a416f0102020740be1e9b66.html>

World Bank (2017). The Growing Role of Minerals and Metals for a Low Carbon Future.

World Mining Data (2019). Bundesministerium für Nachhaltigkeit und Tourismus. Austrian Federal Ministry of Sustainability and Tourism. [online] Available at: [www.en.bmwf.gv.at/Energy/WorldMiningData/Seiten/default.aspx](http://www.en.bmwf.gv.at/Energy/WorldMiningData/Seiten/default.aspx)

### **23.7.2 Data sources used in the criticality assessment**

BGS (2019). European Mineral Statistics. [online] Available at: <https://www.bgs.ac.uk/mineralsuk/statistics/europeanStatistics.html>

Bio Intelligence Service (2015). Study on Data for a Raw Material System Analysis: Roadmap and Test of the Fully Operational MSA for Raw Materials – Final Report. Prepared for the European Commission, DG GROW.

European Commission (2016). DG Trade. Agreements [online] Available at: <http://ec.europa.eu/trade/policy/countries-and-regions/agreements/>

European Commission (2017). Report on Critical Raw Materials for the EU. [online] Available at: [https://ec.europa.eu/growth/sectors/raw-materials/specific-interest/critical\\_en](https://ec.europa.eu/growth/sectors/raw-materials/specific-interest/critical_en)

Eurostat (2019a). International Trade Easy Comext Database [online] Available at: <http://epp.eurostat.ec.europa.eu/newxtweb/> ; CN8 codes used in the EU supply: 28046100 (100% Si contained) and 28046900 (99% Si contained).

Lauri, L.S., Eilu, P., Brown, T., Gunn, G., Kalvig, P., Sievers, H (2018). Identification and quantification of primary CRM resources in Europe. Deliverable D3.1 of the project SCRREEN, 63p., issued on 28.02.2018. Available at: <http://screen.eu/results/>, accessed 19.11.2019

OECD (2019). Export restrictions on Industrial Raw Materials database. [online] Available at: [http://qdd.oecd.org/subject.aspx?Subject=ExportRestrictions\\_IndustrialRawMaterials](http://qdd.oecd.org/subject.aspx?Subject=ExportRestrictions_IndustrialRawMaterials)

Plastics Insights (2017). Polyvinyl Chloride (PVC) Properties, Production, Price, Market, and Uses. Available online at: <https://www.plasticsinsight.com/resin-intelligence/resin-prices/pvc/>

SCRREEN workshop. (2019). Validation Workshop on Critical Raw Materials, 10-12 September 2019, Thon Hotel Brussels City Centre.

Tercero, L., Stotz, H., Otmar Deubzer, García, R. B., Lepe, G. R., Bilewska, K., ... Hu, X. (2018). SCRREEN D5.1 Critical Raw Material substitution profiles. In SCRREEN - D5.1. Retrieved from <http://screen.eu/wp-content/uploads/2018/05/SCRREEN-D5.1-CRM-profiles.pdf>

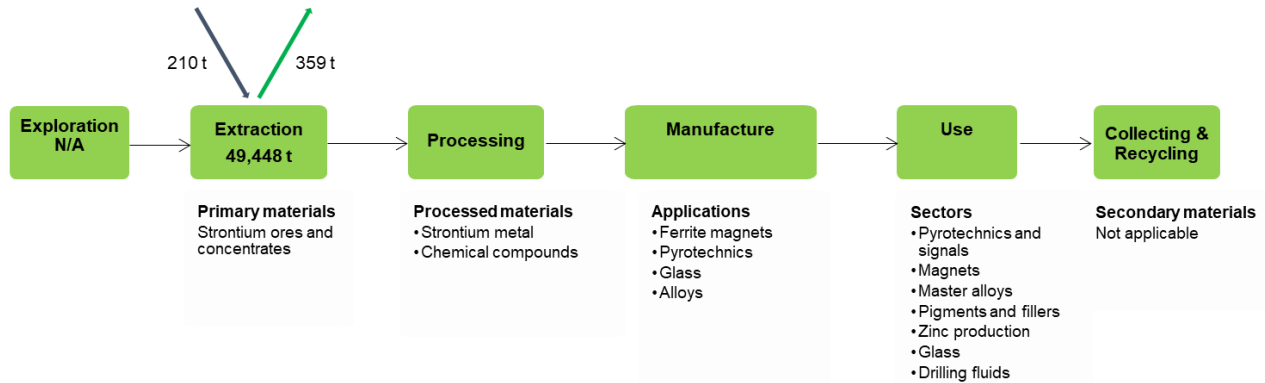
## **23.8 Acknowledgments**

---

This factsheet was prepared by the JRC. The authors would like to thank SCRREEN experts network, the EC Ad Hoc Working Group on Critical Raw Materials and all other relevant stakeholders for their contributions to the preparation of this Factsheet.

# 24 STRONTIUM

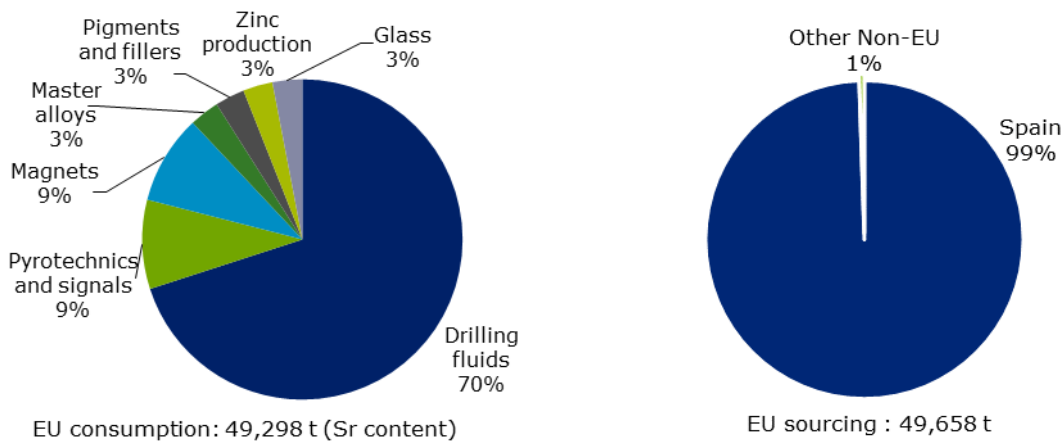
## 24.1 Overview



**Figure 464: Simplified value chain for Strontium for the EU<sup>264</sup>, average 2012-2016**

Strontium (chemical symbol Sr) is a metal usually occurring in the earth’s crust as celestite (SrSO<sub>4</sub>) and strontianite (SrCO<sub>3</sub>), and it is also present in seawater. It is a soft, silver-yellow, alkaline-earth metal, and has a high reactivity with water and air. (Lenntech, 2019; ISE, 2019). The criticality of Strontium for the EU is analysed for the first time.

For the purpose of this assessment the extraction stage of Strontium is analysed using BGS data for production figures of strontium minerals and CN8 code 28369200 “Strontium Carbonate” for trade data. In order to ensure comparability, both production and trade figures are converted to Strontium content. Unfortunately, codes 28051910 “Strontium and Barium” and 261640 “Oxides, Hydroxides, Peroxides, of Strontium or Barium” could not be used because the amounts of barium and strontium could not be separated. Celestite and strontium nitrate trade are not recorded by Eurostat Comext (2019).



**Figure 465: End uses (USGS, 2019) and EU sourcing (BGS, 2019; Eurostat, 2019) of Strontium, 2012-2016 average**

<sup>264</sup> JRC elaboration on multiple sources (see next sections)

The average value of strontium carbonate market between 2012 and 2016 was USD 59.2 million. Imports are dominated by Japan (23%) and South Korea (21%) (OEC, 2019).

The apparent consumption of strontium of EU is about 49,300 tonnes per year, averaged over 2012-2016. Main source is Spain supplying almost 100% of EU's strontium demand. Other marginal suppliers are China, Japan, Mexico and Canada.

The EU is a net exporter of strontium, exporting an average of 360 tonnes per year between 2012 and 2016 and importing 210 t. The largest share of strontium is exported to South Korea (36%), followed by India (19%) and Japan (18%) (Eurostat, 2019a).

Strontium compounds are mainly used by ceramics, glass and pyrotechnics industries. For example, strontium carbonate is used to produce permanent ceramic ferrite magnets (applied in small direct current motors, such as windshield wipers), strontium nitrate is used to produce bright red coloured pyrotechnic applications. Strontium metal can be used as an alloy for aluminium to improve strength and ductility for aerospace and automotive applications. Moreover, strontium has a number of medical applications including bone cancer treatment (USGS, 2018).

According to USGS (2019) world resources of strontium are approximately 1 billion tonnes. In the EU Spain has the biggest celestite resources, estimated at 3.6 Mt.

The total world production of strontium is 159,541 tonnes (334,455 tonnes of strontium minerals) per year between 2012 and 2016. Spain was the biggest supplier producing 31% of global supply, followed by Iran (31%), China (19%), Mexico (17%), and Argentina (2%). (BGS, 2019)

The End-of-Life Recycling Input Rate (EoL-RIR) of Strontium is below 1% (UNEP, 2011; SCRREEN workshops, 2019)

Strontium chromate ( $\text{CrO}_4\text{Sr}$ ) is labelled a carcinogen, very toxic to aquatic life with long lasting effects and harmful when swallowed by the European Chemicals Agency (ECHA, 2019). Its use requires prior authorisation.

This compound was used as an additive for paints in order to prevent corrosion of aluminium parts for aircraft fuselages and ships (USGS, 2018). It is also on the hazardous substances list in the US, regulated by OSHA.

Strontium ranelate is a prescription drug for osteoporosis patients. However, studies show a possible link between the drug and cardiovascular risks. The European Medicines Agency limited its use to patients that cannot take other osteoporosis medication. (USGS, 2018)

## **24.2 Market analysis, trade and prices**

---

### **24.2.1 Global market analysis and outlook**

The global market value of strontium carbonate was USD 59.2 million on average in the period 2012-2016, decreasing from USD 64.5 million in 2012 to USD 53.8 million in 2016. In 2017 the market value remained approximately the same as in 2016 (OEC, 2019; USGS, 2019; SCRREEN workshops, 2019).

The main exporter of strontium carbonate is by far Germany with an average market share of 57%. This share is continuously increasing from 49% in 2012 to 63% in 2016. The second largest exporter was Mexico (22%), followed by China (12%) between 2012 and 2016.

The largest importers of strontium carbonate are Japan (23%), South Korea (21%), and the USA (13%) (OEC, 2019).

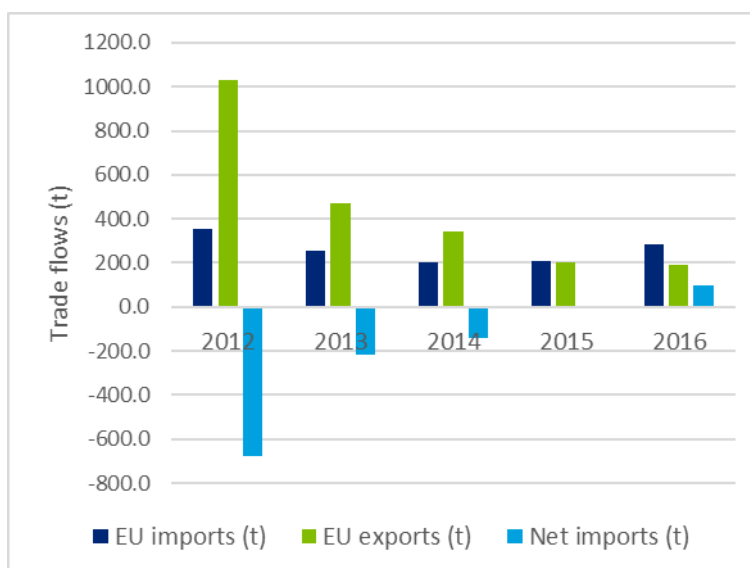
Strontium will very likely continue to be an important material for ferrite-magnets, ceramics, glass, and pyrotechnics production. As was previously the case, strontium use in oil and gas drilling will continue to be subject to baryte, and oil and gas price trends. Ongoing research in the use of strontium in optical applications or semiconductors might lead to new end uses in the future (USGS, 2019).

**Table 192: Qualitative forecast of supply and demand of Strontium**

Materials	Criticality of the material in 2020		Demand forecast			Supply forecast		
	Yes	No	5 years	10 years	20 years	5 years	10 years	20 years
Strontium	x		+	?	?	+	?	?

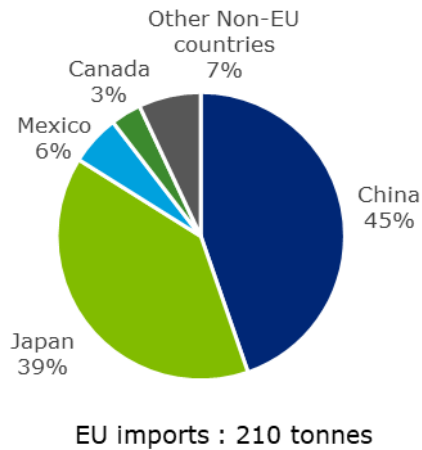
### 24.2.2EU trade

The EU is a net exporter of strontium the average export (360 tonnes per year) being almost 200 tonnes higher than the average import (210 tonnes per year) in the period 2012-2016. However, the amount of exported strontium is decreasing during this time period and in 2015 and 2016 there is a slight surplus of imports.



**Figure 466: EU trade flows for Strontium (Eurostat, 2019b)**

Though with marginal quantities, the main external suppliers for the EU are China (45%), Japan (40%), Mexico (6%) and Canada (3%). There are EU trade agreements in place with Japan, Mexico and Canada (European Commission, 2019). At the moment, there are no exports, quotas or prohibition in place between the EU and its trade partners (Morocco imposes export restrictions on strontium carbonate, but between 2012 and 2016 it was not a trade partner of the EU) (OECD, 2019).



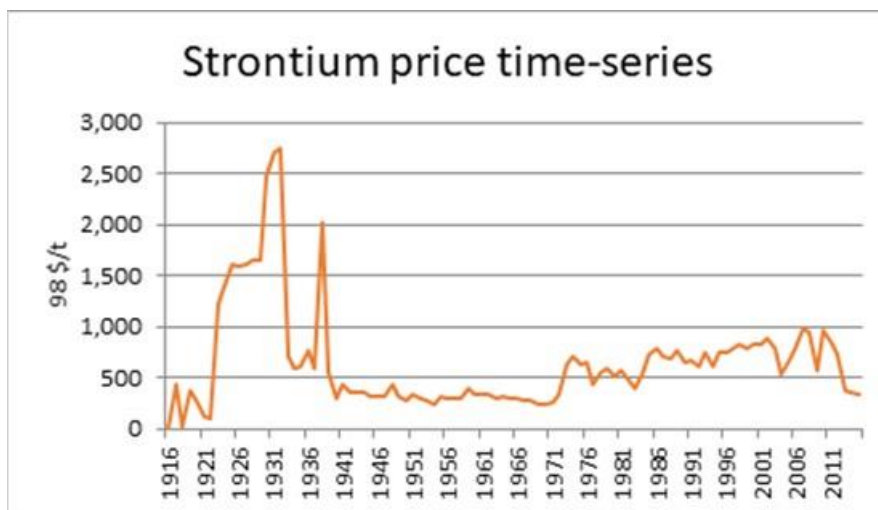
**Figure 467: EU imports of Strontium, average 2012-16 (Eurostat, 2019b)**

### 24.2.3 Prices and price volatility

Strontium is traded both in form of the mineral celestite, and in form of strontium chemicals and metal. Prices are usually reported in US Dollar per tonne.

USGS records unit values for strontium since 1916, Figure 468 shows price trends until 2015. In previous years prices show a rather high volatility, especially 2004 and 2009 significant price drops were recorded. In 2009 prices decreased by 40% compared to the previous year. After quickly recovering already in 2010 prices decreased again until 2015.

Since 2016 an increase has been registered with celestite prices at USD 78 per tonne in 2016, USD 74 per tonne in 2017 and USD 75 per tonne in 2018.



**Figure 468: Prices of strontium (USD per tonne, converted to consumer price index 1998) from 1916 to 2015 (USGS, 2019)**

## 24.3 EU demand

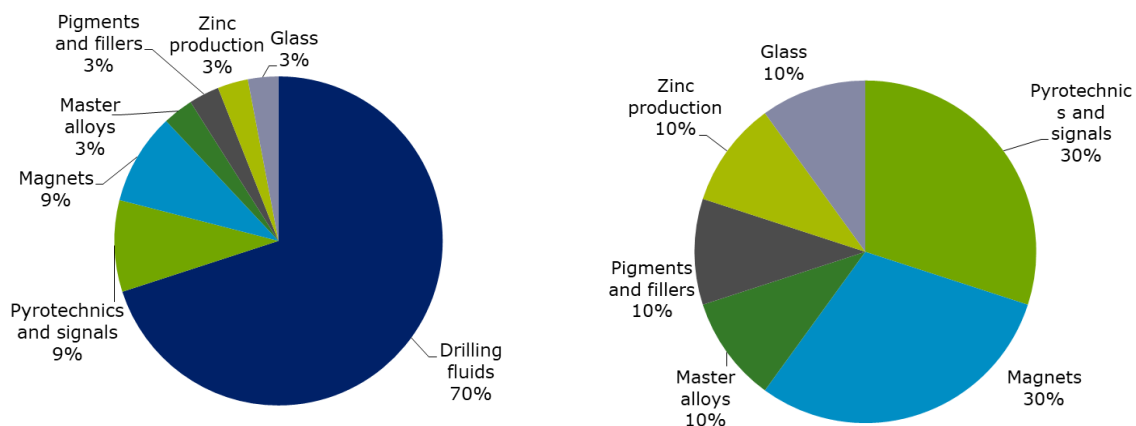
The world global production of strontium is about 159,541 tonnes per year averaged over 2012-2016 (Sr content) at a total market value of USD 59.2 million.

### 24.3.1 EU demand and consumption

The main strontium producer in the EU is Spain and the amount of production is sufficient to supply almost 100% of EU demands. In total 49,650 tonnes of strontium were sourced per year between 2012 and 2016. Other suppliers include China, Japan, Mexico, and Canada. On average the EU consumed 49,300 tonnes per year of strontium in this period.

### 24.3.2 Uses and end-uses of Strontium in the EU

Figure 469 presents the main uses of all strontium compounds including celestite according to USGS. However, it is questionable if this distribution is valid for EU consumption as well, because there are not as many oil and gas drilling projects as in the USA. Unfortunately, no other sources could be found. If only strontium compounds are considered the distribution looks very different (see Figure 469), and this is more likely to represent European consumption.



**Figure 469: US end uses of Strontium compounds including celestite (left) and Strontium compounds excl. celestite (right). (USGS, 2019; USGS, 2017)**

The main end-use of strontium products provided in Figure 469 can be summarised as follows (USGS, 2019):

- Celestite can be used directly in drilling muds for natural gas and crude oil wells, as a substitute for baryte. The amount of strontium used for this application depends on baryte prices.
- A common application of strontium nitrate is as a colouring agent in pyrotechnic applications. It is used to produce bright red colours in fireworks or warning flares for example (alternatively strontium chloride, strontium oxalate, and strontium sulphate can be used). In combination with copper a purple colour can be achieved.
- Permanent ceramic ferrite magnets for small direct current motors, used in automobile windshield wipers, loudspeakers, toys, etc., apply strontium carbonate because it provides effectiveness at high temperatures, low densities, and resistance to corrosion and demagnetisation.
- Previously, the main application of strontium oxide was as glass modifier for cathode-ray-tubes which have almost been completely replaced by flat panel displays. However,

strontium oxide is still used for the production of fiberglass, lab glass and pharmaceutical glass. It enhances optical properties, increases hardness and strength, and intensifies light refraction.

- Strontium oxide and strontium carbonate can be used as nontoxic alternative to barium and lead as frits in ceramic glazes.
- Metallurgy:
  - In aerospace and automotive applications strontium metal is added to aluminium alloys to improve strength and ductility of castings.
  - In Zinc production it can be added to the electrolysis to remove lead impurities.
- Strontium chromate is a corrosion inhibitor previously used in paints, but it is now known that strontium chromate is a carcinogen in humans. Therefore, the European Chemicals Agency limits and monitors its use closely. An alternative is a calcium-strontium-phosphate complex on a silicate core.
- Medical Applications:
  - Strontium ranelate is used in prescription drugs to reduce the occurrence of fractures in osteoporosis patients. However, these drugs are believed to be connected to cardiovascular risks. The European Medicines Agency approved strontium ranelate only for osteoporosis patients that cannot take other medications.
  - The isotope strontium-89 is used for the treatment of bone cancer.
  - Strontium chloride is used in toothpastes to treat temperature- and pressure sensitivity.
- Applications where phosphorescent pigments are needed, for example emergency exits signs, use strontium oxide aluminate as it glows brighter and longer than other pigments.
- Low amounts of strontium are used as a getter in vacuum tubes to remove last traces of air.
- Strontium has many other uses similar to those of calcium and barium, but due to higher costs it is rarely applied. (Lenntech, 2019)
- There is research ongoing for the use of strontium in other high-tech industries which may prove as a future consumer of strontium (semi- and superconductors, memory chips, optical and piezoelectric applications).

Relevant industry sectors are described using the NACE sector codes (Eurostat, 2019a).

**Table 193: Strontium applications (USGS, 2019), 2-digit and associated 4-digit NACE sectors, and value added per sector (Eurostat, 2019a)**

<b>Applications</b>	<b>2-digit NACE sector</b>	<b>Value added of NACE 2 sector (M€)</b>	<b>4-digit NACE sectors</b>
Colouring agent in pyrotechnic applications	C20 – Manufacture of chemicals and chemical products	405.76	C2051 – Manufacture of explosives
Permanent ceramic ferrite magnets for small direct current motors	C28 – Manufacture of machinery and equipment not elsewhere classified	1903,64	C2849 – Manufacture of other machine tools
Production of fiberglass, lab glass	C23 – Manufacture of other non-metallic mineral products	13719,72	C231 – Manufacture of glass and glass products



<b>Applications</b>	<b>2-digit NACE sector</b>	<b>Value added of NACE 2 sector (M€)</b>	<b>4-digit NACE sectors</b>
and pharmaceutical glass			
Alloys for aluminium in automotive and aerospace applications	C24 - Manufacture of basic metals	4165,08	C2453 - Casting of light metals
Electrolytic production of zinc to remove lead impurities	C24 - Manufacture of basic metals	237,68	C2443 - Lead, zinc and tin production
Phosphorescent pigments (e.g. exit signs)	C20 - Manufacture of chemicals and chemical products	2262,28	C2012 - Manufacture of dyes and pigments-
Drilling fluids	C23 - Manufacture of other non-metallic mineral products	13719,72	

### 24.3.3 Substitution

In drilling muds the alternative material for strontium carbonate is baryte, which is normally preferred. However, when the price of baryte gets too high, demand shifts to strontium.

Ferrite ceramic magnets can also be produced using barium instead of strontium, accepting a reduced maximum operating temperature (USGS, 2019; SCREEN workshops, 2019).

## 24.4 Supply

---

### 24.4.1 EU supply chain

Strontium production in the EU provides for 100% of EU demand. Spain is the biggest producer of celestite worldwide, producing an average of 103,660 tonnes per year in the period of 2012-2016. Imports are coming from China (45%), Japan (39%), Mexico (6%) and Canada (3%). The main consumer of EU exports is South Korea (37%), followed by India (19%) and Japan (19%). These numbers result in an import reliance close to zero (Eurostat, 2019a; BGS, 2019).

There are only two mines in Granada. The owners are Canteras Industriales, S.A. and Solvay Minerales, S.A. Industriales SL mines yearly a little quantity but obtain the rest of its production from the waste of the celestite mined some years ago. The content of this waste is between 70 and 80% of SrSO<sub>4</sub>. The company send the production to Solvay plant. Solvay has celestite with a lower content of SrSO<sub>4</sub>. They process the two mines production to obtain a product with more than 90% of SrSO<sub>4</sub>. Total production approximately 100,000 tonnes per year. Canteras Industriales sell 3,000-7,000 tonnes to "Química del Estroncio, SL", and a similar quantity to China.

## 24.4.2 Supply from primary materials

### 24.4.2.1 Geology, resources and reserves of Strontium

**Geological occurrence:** Strontium is part of the earth's crust with 0.037%. It also occurs in seawater. Due to its reactivity strontium does not occur in its native form, but always in compounds. The minerals that are most important for production due to their strontium content of around 50% are celestite (SrSO<sub>4</sub>) and strontianite (SrCO<sub>3</sub>). Celestite deposits were formed by precipitation of strontium sulfate of low solubility from seawater, and strontianite can form hydrothermally or as secondary mineral from celestite. (ISE, 2019)

**Global resources and reserves<sup>265</sup>:** According to USGS (2019) world resources of strontium exceed 1 billion tonnes. Reserves are estimated at 6.8 Mt.

Active mines can be found in Spain, Iran, China, Mexico and China. However, large celestite deposits have been discovered globally. Barium and Calcium impurities can often lead to a deposit being not economically mineable as their removal is very energy and therefore cost intensive. (USGS, 2018)

#### **EU resources and reserves<sup>266</sup>:**

About 3.6 million tonnes of celestite are located in Spain. Resource data for some countries in Europe are available at Minerals4EU (2019), as reported in Table 194.

**Table 194: Resource data for Europe compiled in the European Minerals Yearbook of Minerals4EU (2019)**

Country	Reporting code	Quantity	Unit	Grade	Code Resource Type
Spain	-	3,600,000	t	Contained SrSO <sub>4</sub>	Historic Resource Estimates
United Kingdom	-	500,000	t	-	Historic Resource Estimates

<sup>265</sup> There is no single source of comprehensive evaluations for resources and reserves that apply the same criteria to deposits of strontium in different geographic areas of the EU or globally. The USGS collects information about the quantity and quality of mineral resources but does not directly measure reserves, and companies or governments do not directly report reserves to the USGS. Individual companies may publish regular mineral resource and reserve reports, but reporting is done using a variety of systems of reporting depending on the location of their operation, their corporate identity and stock market requirements. Translations between national reporting codes are possible by application of the CRIRSCO template, which is also consistent with the United Nations Framework Classification (UNFC) system. However, reserve and resource data are changing continuously as exploration and mining proceed and are thus influenced by market conditions and should be followed continuously.

<sup>266</sup> For Europe, there is no complete and harmonised dataset that presents total EU resource and reserve estimates for strontium. The Minerals4EU project is the only EU-level repository of some mineral resource and reserve data for strontium, but this information does not provide a complete picture for Europe. It includes estimates based on a variety of reporting codes used by different countries, and different types of non-comparable datasets (e.g. historic estimates, inferred reserves figures only, etc.). In addition, translations of Minerals4EU data by application of the CRIRSCO template is not always possible, meaning that not all resource and reserve data for strontium the national/regional level is consistent with the United Nations Framework Classification (UNFC) system (Minerals4EU 2019). Many documented resources in Europe are based on historic estimates and are of little current economic interest. Data for these may not always be presentable in accordance with the UNFC system. However a very solid estimation can be done by experts.

Reserves located in Europe are shown in Table 195 (Minerals4EU, 2019).

**Table 195: Reserve data for Europe compiled in the European Minerals Yearbook of the Minerals4EU website (Minerals4EU, 2019)**

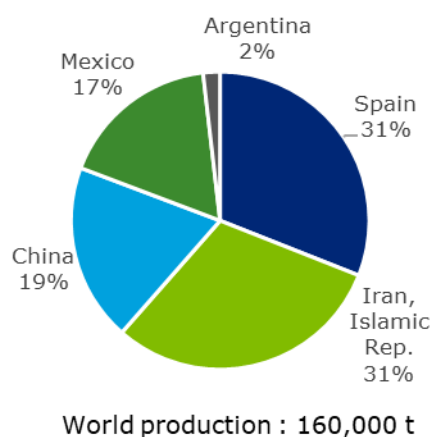
Country	Reporting code	Quantity	Unit	Grade	Code Reserve Type
Spain	-	3,743,000	t	-	Proven Reserve
Ukraine (Strontium ore)	Russian Classification	180,670,000	t	-	(RUS) B
Ukraine (Strontium ore)	Russian Classification	678,957,000	t	-	(RUS) C1
Ukraine (Strontium oxide contained)	Russian Classification	191,000	t	-	(RUS) B
Ukraine (Strontium oxide contained)	Russian Classification	674,000	t	-	(RUS) C1

#### 24.4.2.2 World and EU mine production

Only a few countries produce strontium worldwide: Spain and Iran are the largest suppliers (about 31% each), followed by China (19%), Mexico (17%), and Argentina (2%). Between 2012 and 2016 an average of 334,455 tonnes of strontium minerals were produced per year. The Iranian production dropped significantly from 2012 to 2013 to only one quarter of previous amounts (188,790 tonnes in 2012 – 46,240 tonnes in 2013), so did the strontium minerals production in Argentina. While Iran managed to increase amounts again in 2016 to similar levels as before (196,689 t), Argentinian production remained low (1,000 t). Spain, however, increased the production from 2013 to 2014 by almost 40,000 tonnes. In 2016 the amount decreased again to previous levels. (BGS, 2019) The main producer in Spain is Solvay.

In 2017 Iran, Spain and Mexico increased their production leading to a world total of 391,362 tonnes. (BGS, 2019)

A notable increase in production is expected in the coming years due to the growth in demand for strontium ore by China. Although China has proven reserves its celestite has worse characteristics than celestite found in Spain or Mexico. Therefore, China has to rely on imports. (Instituto Geológico y Minero de España, 2017)



**Figure 470: Global mine production of Strontium, 2012-2016 (BGS, 2019).**

### **24.4.3 Supply from secondary materials/recycling**

According to UNEP (2011), the End-of-Life Recycling Input Rate of Strontium is below 1%. Therefore, strontium from secondary sources is not considered in this evaluation (EoL-RIR=0).

### **24.4.4 Processing of strontium**

Usually mines produce celestite which is then turned into strontianite. This is done by heating celestite with carbon and thereby reducing to strontium sulphide. There are two possibilities for further processing depending on availability of the necessary reactants. Either carbon dioxide is passed through the strontium sulphide producing strontianite and hydrogen sulphide, or strontium sulphide is reacted with sodium carbonate producing strontianite and sodium sulphide. It is also possible to obtain strontianite in one reaction step, by reacting finely ground celestite with sodium or ammonium carbonate. However, this requires preliminary extensive cleaning, and is therefore rarely conducted.

Strontianite is the raw material for other strontium compounds, and for producing strontium metal.

In order to produce strontium metal strontianite has to be turned into strontium oxide, which is then reduced to elemental strontium in a reaction with aluminium in vacuum. (ISE, 2019)

## **24.5 Other considerations**

---

### **24.5.1 Environmental and health and safety issues**

As already mentioned before, there are certain compounds of strontium that pose health and environmental risks.

Strontium used to be added to paints in form of strontium chromate to prevent corrosion. (USGS, 2018) As is now known, strontium chromate is a carcinogen in humans, and therefore, its use is subject to authorisation and strict monitoring by the European Chemicals Agency. It is also harmful to aquatic life and can have long lasting effects. (ECHA, 2019)

Strontium is used in strontium ranelate, a prescription drug for osteoporosis patients, to reduce susceptibility to bone fractures. However, this drug is believed to be connected to cardiovascular risks. Therefore, the European Medicines Agency allows it only to be used by patients who cannot take other available osteoporosis pharmaceuticals. (USGS, 2018)

One of strontium's isotopes, Sr-90, that is released into the atmosphere by nuclear fallouts is a beta emitter. Nuclear testing by the USA between 1940 and 1960 and nuclear reactor accidents in Chernobyl (1986) and Fukushima (2011) released high levels of Sr-90, that were eventually absorbed into grasslands, leading to intake by cows and therefore high concentrations in dairy products. Strontium-90 can be absorbed by bone tissue, replacing calcium, eventually destroying bone marrow and leading to cancer. (ISE, 2019)

### **24.5.2 Socio-economic issues**

No specific issues were identified during data collection and stakeholders consultation.

## 24.6 Comparison with previous EU assessments

Strontium has not been assessed in previous criticality studies. The results for Economic Importance and Supply Risk of the current study can be seen in Table 196.

**Table 196: Economic importance and supply risk results for Strontium in the assessments of 2020**

Assessment	2011	2014	2017	2020	
Indicator	not assessed	not assessed	not assessed	EI	SR
Strontium				3,50	2,57

## 24.7 Data sources

Data for the use of strontium in the EU, as well as price trends in Euro were not available at the time of the assessment.

### 24.7.1 Data sources used in the factsheet

BGS (2019). World Mineral Production 2013-2017. Available at: <https://www.bgs.ac.uk/mineralsuk/statistics/worldStatistics.html>

ECHA (2019). Substance information [Online]. Available at: [https://echa.europa.eu/de/substance-information/-/substanceinfo/100.029.220?\\_disssubinfo\\_WAR\\_disssubinfoportlet\\_backURL=https%3A%2F%2Fecha.europa.eu%2Fde%2Finformation-on-chemicals%3Fp\\_p\\_id%3Ddisssimplesearchhomepage\\_WAR\\_dissearchportlet%26p\\_p\\_lifecycle%3D0%26p\\_p\\_state%3Dnormal%26p\\_p\\_mode%3Dview%26p\\_p\\_col\\_id%3D\\_118\\_INSTANCE\\_UFgbrDo05Elj\\_\\_column-1%26p\\_p\\_col\\_count%3D1%26\\_disssimplesearchhomepage\\_WAR\\_dissearchportlet\\_sessionCriteriaId%3D](https://echa.europa.eu/de/substance-information/-/substanceinfo/100.029.220?_disssubinfo_WAR_disssubinfoportlet_backURL=https%3A%2F%2Fecha.europa.eu%2Fde%2Finformation-on-chemicals%3Fp_p_id%3Ddisssimplesearchhomepage_WAR_dissearchportlet%26p_p_lifecycle%3D0%26p_p_state%3Dnormal%26p_p_mode%3Dview%26p_p_col_id%3D_118_INSTANCE_UFgbrDo05Elj__column-1%26p_p_col_count%3D1%26_disssimplesearchhomepage_WAR_dissearchportlet_sessionCriteriaId%3D) (Accessed: 03.09.2019)

Eurostat (2019a). Annual detailed enterprise statistics for industry (NACE Rev. 2, B-E) [Online]. Available at: [https://ec.europa.eu/eurostat/en/web/products-datasets/-/SBS\\_NA\\_IND\\_R2](https://ec.europa.eu/eurostat/en/web/products-datasets/-/SBS_NA_IND_R2) (Accessed: 05.09.2019)

Eurostat (2019b). Comext International Trade [Online]. Available at: <http://epp.eurostat.ec.europa.eu/newxtweb/mainxtnet.do> (Accessed: 30.08.2019)

Institut für seltene Erden (ISE) (2019). Strontium [Online]. Available at: <https://institut-seltene-erden.de/seltene-erden-und-metalle/strategische-metalle-2/strontium/> (Accessed: <https://institut-seltene-erden.de/seltene-erden-und-metalle/strategische-metalle-2/strontium/>)

Instituto Geológico y Minero de España (2017). Panorama Minero 2017. p. 533. Available at: [http://www.igme.es/PanoramaMinero/actual/PANORAMA\\_MINERO\\_2017\(BU24\)\(BR\).pdf](http://www.igme.es/PanoramaMinero/actual/PANORAMA_MINERO_2017(BU24)(BR).pdf)

Lenntech BV (2019). Periodic Table – Strontium [Online]. Available at: <https://www.lenntech.com/periodic/elements/sr.htm> (Accessed 02.09.2019)

Minerals4EU (2019). European Minerals Yearbook. [Online] Available at: <http://minerals4eu.brgm-rec.fr/m4eu-yearbook/pages/bycommodity.jsp?commodity=Strontium> (Accessed: 02.09.2019)

OEC (2019). Strontium Carbonate Trade [Online]. Available at: <https://oec.world/en/profile/hs92/283692/> (Accessed: 13.09.2019)

OEDC (2019). Export restrictions on Industrial Raw Materials [Online]. Available at: [https://qdd.oecd.org/subject.aspx?Subject=ExportRestrictions\\_IndustrialRawMaterials](https://qdd.oecd.org/subject.aspx?Subject=ExportRestrictions_IndustrialRawMaterials) (Accessed: 03.09.2019)

SCRREEN workshop. (2019). "Validation Workshop on Critical Raw Materials, 10-12 September 2019, Thon Hotel Brussels City Centre."

UNEP (2011). Recycling Rates of Metals. Available at: <https://www.resourcepanel.org/reports/recycling-rates-metals>

USGS (2017). Historical Statistics for Mineral and Material Commodities in the United States. Available at: <https://www.usgs.gov/centers/nmic/historical-statistics-mineral-and-material-commodities-united-states>

USGS (2018). 2016 Minerals Yearbook – Strontium [Advanced Release]. Available at: <https://www.usgs.gov/centers/nmic/strontium-statistics-and-information>

USGS (2019). Mineral Commodity Summaries – Strontium. Available at: <https://www.usgs.gov/centers/nmic/strontium-statistics-and-information>

## **24.7.2 Data sources used in the criticality assessment**

BGS, World mineral statistics data 2019

USGS Mineral Commodity Summaries 2019

Eurostat - Comext database - Code 28369200 "Strontium Carbonate"

T.E. Graedel, 2015, On the materials basis of modern society - supplementary file; Proc Natl Acad Sci USA. 2015 May 19; 112(20): 6295–6300

Study on the review of the list of Critical Raw Materials, 2017

EU Trade Negotiations and agreements - <http://ec.europa.eu/trade/policy/countries-and-regions/agreements/>

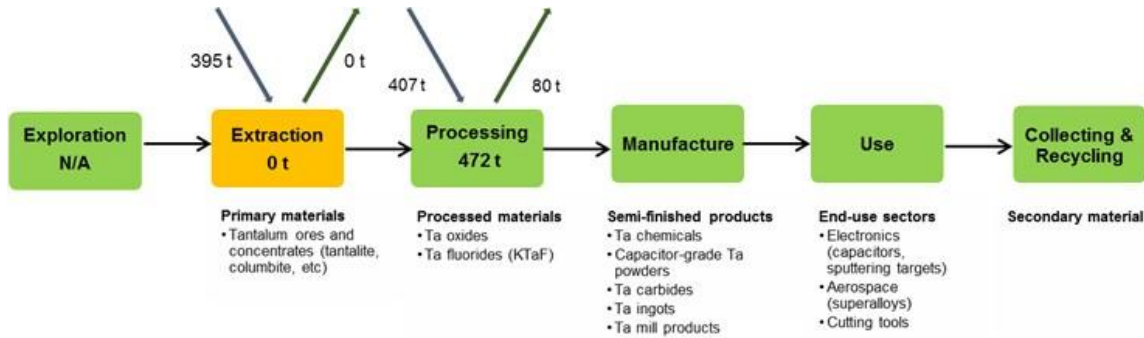
## **24.8 Acknowledgments**

---

This factsheet was prepared by the JRC in collaboration with Ms. Marie-Theres Kügerl (Resources Innovation Center Leoben). The authors would like to thank the Ad Hoc Working Group on Critical Raw Materials, in particular Euromines, as well as experts participating in SCRREEN workshops (Ms. Carmen Marchán Sanz, Dirección General de Política Energética y Minas, Spain) for their valuable contribution and feedback.

# 25 TANTALUM

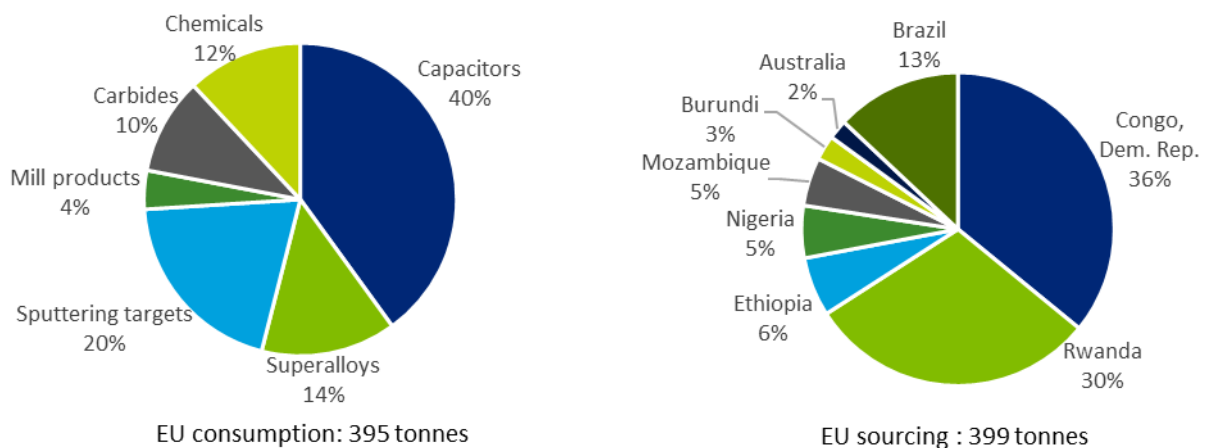
## 25.1 Overview



**Figure 471: Simplified value chain for tantalum for the EU, averaged over 2012-2016<sup>267</sup>**

Tantalum (chemical symbol Ta) is a silvery-grey hard, transition metal. It has a high density (16.6 g/cm<sup>3</sup>) and the fourth highest melting point (3,020°C). It is highly resistant to corrosion and has a great permittivity. Tantalum's estimated abundance in the upper continental crust is 0.9 ppm (Rudnick, 2003), which is quite rare. It is not found as a free metal in nature but occurs notably in the minerals microlite and tantalite-columbite. Most tantalum is produced as a co-product as it occurs in complex mineral form, often associated in ore bodies with niobium, tin or lithium. Tantalum was on the list of CRMs in 2011 and 2017, but not in 2014.

For the purpose of this assessment, the criticality of tantalum was assessed at mine stage in ores and concentrates form. The trade code for tantalum is CN 261590, "Niobium, Tantalum & Vanadium Ores & Concentrates" (Eurostat Comext, 2019).



**Figure 472: End uses (SCREEN, 2019) and EU sourcing of tantalum ores and concentrates, average 2012-2016 (T.I.C, 2019).**

<sup>267</sup> JRC elaboration from multiple sources (see next sections). The orange box of the extraction stage suggest that extraction activity is not undertaken within the EU.

Tantalite (30% Ta<sub>2</sub>O<sub>5</sub>) prices on the international market decreased from 2014's price at USD 187 per kg of Ta<sub>2</sub>O<sub>5</sub>, reaching the lowest at around USD 124 per kg in 2016. Since then, the price of tantalum has increased, up to USD 203 per kg of Ta<sub>2</sub>O<sub>5</sub> in 2018.

The EU is a net importer of tantalum ores and concentrates. The EU annual average consumption of tantalum over the period 2012-2016 was estimated to be around 395 tonnes per year (T.I.C, 2019). The EU sourced tantalum mainly from African suppliers.

The main uses of tantalum are in capacitors (electronic devices, cell phones etc.), superalloys (aerospace), sputtering targets (storage media, inkjet printer heads etc.), but also carbides (cutting tools), mill products, medicals and chemicals. The current tantalum consumption is limited to those applications in which tantalum cannot be substituted without a significant loss of performance and quality (European Commission, 2017).

Tantalum, together with tungsten are indispensable for the whole manufacturing and tooling industry, i.e. robotics and Artificial Intelligence. No manufacturing of solar panels, wind turbines, etc. would be possible without tooling industry (Euromines, 2019).

USGS indicates that identified resources of tantalum are located in Australia, Brazil, and Canada. Some deposits were also identified in the United States, but they were considered uneconomic at 2018 prices for tantalum. In Europe, potential resources of tantalum (and niobium) were reported to exist in Finland, France, Portugal, Norway, Sweden, Greenland and Germany with no further evaluation (Mineras4EU,2014). Reserves of tantalum were identified in Australia and in Brazil, although this information may be incomplete (USGS, 2019). No reserves of tantalum in the EU were identified.

The world annual production of tantalum over the period 2012-2016 was reported at 1,190,000 tonnes. More than half of this quantity was produced in Democratic Republic of Congo (33%) and Rwanda (28%) (WMD, 2019). The major part of supply in recent years comes from artisanal mining. There was no production of tantalum in the EU. Processor scrap and other secondary materials are another important part of tantalum supply. In the EU, various recyclers and processors count tantalum in their activities. They are located in Germany, Austria and the UK (Roskill, 2016).

No environmental restriction is known for tantalum. Regulatory issues are linked with Conflict minerals legislation issues (European Parliament, 2016). The production of tantalum is also closely related to the activities of artisanal and small-scale miners (ASM), often operating outside health, safety and environmental standards (RMIS, 2019).

## **25.2 Market analysis, trade and prices**

---

### **25.2.1 Global market analysis and outlook**

On the supply of tantalum, since the late 1990s, the tantalum market has shown much instability and volatility. Much uncertainty comes from the potential development of new deposits. The tantalum market was in a slight supply surplus in 2010-2014, and could remain so for the next few years from 2017, resulting in low prices that discourage new producers coming on stream (European Commission, 2017).

As for supply risks, the level of confidence concerning tantalum trade in Central Africa is a key parameter. Since 2009, many institutional and industry led initiatives have improved



transparency on artisanal mining. Nevertheless the current political instability in the region could have a negative impact on future trade, bringing the notion of conflict tantalum back to prominence again. In the case of new conflicts rising, the risk of another de-facto embargo could weigh on the region and cause a dramatic increase in prices (European Commission, 2017).

On the demand side, SCREEEN carried out a study on major trends affecting future demand for tantalum. The study covered the uses of tantalum as capacitors in smartphones and computers and superalloys in jet engines. The study concluded that the use of tantalum in smartphones should drive the future of tantalum towards 2035 although a higher demand from the superalloys sector is predicted to come. The increase in tantalum requirements are expected to be driven by the growth of demand related to social needs (social network activities, on-line service, etc) and the demand for smaller and more integrated devices (Monnet, 2018).

**Table 197: Qualitative forecast of supply and demand of tantalum**

Materials	Criticality of the material in 2020		Demand forecast			Supply forecast		
	Yes	No	5 years	10 years	20 years	5 years	10 years	20 years
Tantalum	X		+	+	?	?	?	?

### 25.2.2 EU trade

No public data was available to assess the EU imports and exports of tantalum ores and concentrates. Tantalum ores and concentrates in Eurostat-Comext is represented as a mix with niobium and vanadium in CN code 261590: "Niobium, tantalum, or vanadium ores and concentrates". Moreover, Eurostat-Comext returned empty tables for import and export of such commodity. Experts have provided estimation regarding EU imports and exports of tantalum ores and concentrates.

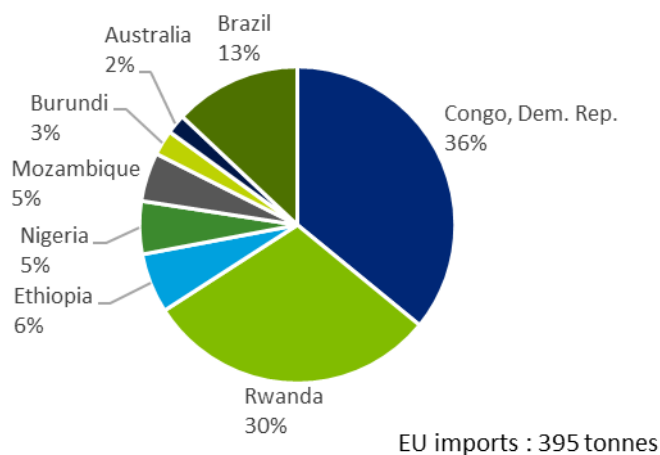
The EU is a net importer of tantalum ores and concentrates. The amount of EU imports at 60-100 tonnes per year of tantalum concentrates as reported in the criticality assessment 2017 (averaged over 2010 to 2014), was considered as too low by experts. T.I.C. (2019) estimates that EU imports of tantalum pentoxides (Ta<sub>2</sub>O<sub>5</sub>) exceed 500 tonnes per year, stable from 2012-2016 period. The EU imported about 395 tonnes of tantalum content per year over the period 2012-2016 (T.I.C., 2019). France and Germany are the main importers of tantalum concentrates (T.I.C., 2019).

The main suppliers for the EU are African countries, i.e. Democratic Republic of Congo (36%), Rwanda (30%), Ethiopia (6%) and Nigeria (5%). The African countries breakdown is an estimate based on the share of each country in global supply.

Burundi, that supplied 3% of EU import imposed 30% of export tax for HS 26159090 "Other", in which tantalum concentrates and ore are a part of it. Rwanda applied "fiscal tax on exports" of 4% on HS 261590 "Niobium, Tantalum & Vanadium Ores & Concentrates" which includes the following HS codes of products: 2615909010 "Niobium, tantalum concentrates and ores" and HS 2615909090 "Vanadium ores and concentrates". Currently there are no EU free trade agreements in place with Rwanda.

The EU production of tantalum in the EU between 2012 and 2016 took place in France, at the rate of 4.9 tonnes per year, that was entirely exported outside the EU (Bourgeois, F. et. al, 2017).

HC Starck in Germany is likely to be one of the main re-exporter of Ta concentrates, linked with intra-company material transfers to Thailand, USA and Japan (Roskill, 2016). In 2018, Tantalum & Niobium Division of HC Starck was reported to have been sold to Japan's JX Group (Roskill, 2018).

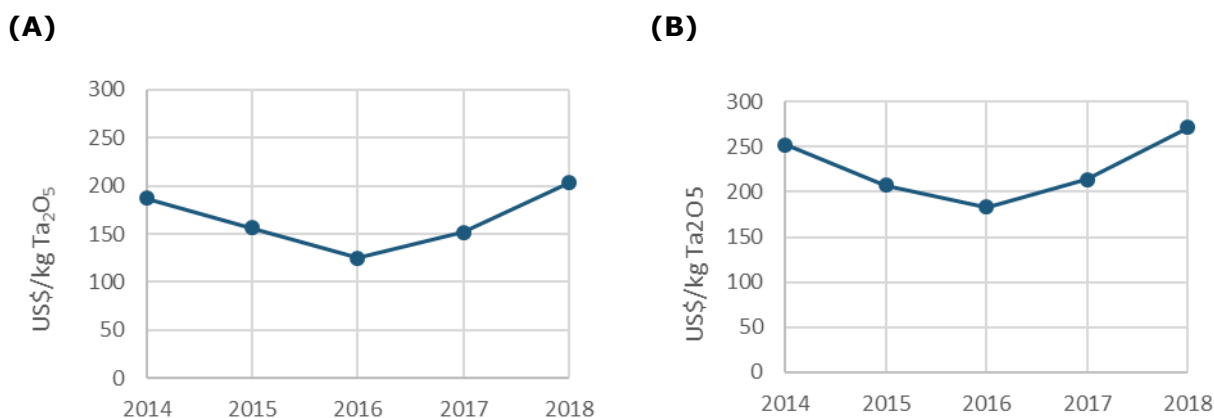


**Figure 473: EU imports of tantalum ores and concentrates, averaged over 2012-2016 (T.I.C., 2019)**

### 25.2.3 Prices and price volatility

Tantalum is not traded on any metals exchange, and there are no terminal or futures markets where buyers and sellers can fix an official price. References for prices are obtained through averages of past deals between private parties, generally available through paid subscription (e.g. Asian Metal, Metal Pages).

Figure 474 shows the prices of tantalum concentrates (30% Ta<sub>2</sub>O<sub>5</sub>) and tantalum pentoxide (min. 99.5% Ta<sub>2</sub>O<sub>5</sub>, fob China). It is also of interest to note that as we move toward the value chain, added-values escalate rapidly for selected tantalum products. The price of tantalum pentoxide (99.5% min. Ta<sub>2</sub>O<sub>5</sub>) is higher than tantalum concentrates.



**Figure 474: Tantalite concentrate (30% Ta<sub>2</sub>O<sub>5</sub>) (A), and pentoxide (min. 99,5% Ta<sub>2</sub>O<sub>5</sub>, fob China) (B) in USD/kg of Ta<sub>2</sub>O<sub>5</sub> Data source: DERA (DERA, 2019)**

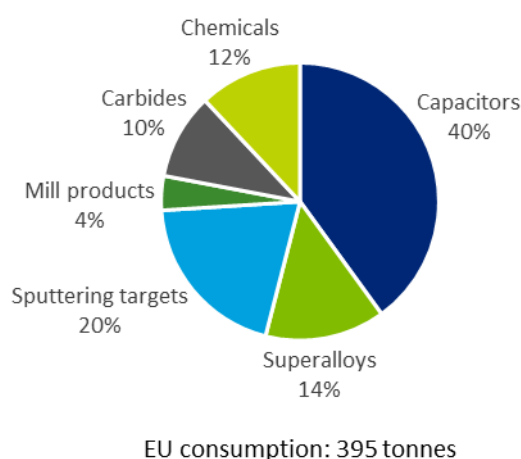
## 25.3 EU demand

### 25.3.1 EU consumption

Apparent consumption figures for tantalum derived from adding EU production and imports and subtracting exports are not reliable because of uncertainties related to the amount of tantalum produced, traded, or integrated in finished goods at every level.

The EU consumption of tantalum concentrates and tantalum pentoxide was estimated to exceed 500 tonnes per year, stable over the year 2012-2016 (T.I.C., 2019). The EU imports was estimated at 395 tonnes annually, equivalent to 25% of the tantalum available in the market in 2012-2016 (T.I.C., 2019). France and Germany were known as the main importer of tantalum in the EU (T.I.C., 2019).

### 25.3.2 Uses and end-uses of tantalum in the EU



**Figure 475: EU end uses of tantalum. Average figures for 2012-2016. (SCREEN, 2019)**

Figure 475 presents the main uses of tantalum in the EU. The manufacture of capacitors is the largest single use of tantalum worldwide. All electronic devices contain capacitors, they are used to store an electrical charge for later use, and consist of two conducting surfaces (metal plates) separated by a dielectric insulating material. In the case of tantalum capacitors, the dielectric is a thin film of tantalum pentoxide that forms naturally on the surface of tantalum metal to protect it from corrosion. The vast majority of capacitors in electronic devices do not contain tantalum; the use of tantalum is favoured when high capacitance, small size and high performance are required. Such capacitors are now limited to applications where they are irreplaceable. In the EU, the majority of tantalum use in capacitors comes from imported finished products rather than manufacturing. In 2016, only one capacitor manufacturer seems to be active, AVX in Czech Republic (European Commission, 2017).

Superalloys are an important use of tantalum in the EU, due to the prominence of the aerospace sector. Roskill estimates that the EU could consume half of tantalum used globally in superalloys (Roskill, 2016). As aircraft design and performance expectations improve, the alloys involved become more sophisticated and the loading of tantalum in alloys is increasing (together with

other specialty metals). Superalloys find applications in the manufacture of jet engines for example, but also for land-based gas turbines.

Sputtering targets are another major application for tantalum although less important in the EU (only in imported finished products). Sputtering is a method of applying thin films of metal to a substrate and is used in the manufacture of storage media, inkjet printer heads, electronic circuitry and flat-panel displays, among others. The target is the source of the metal that is deposited. Tantalum chemicals have a very wide range of applications and are intermediates in the manufacture of other products that are often destined for the electronics industry. Tantalum mill products have a very wide range of uses, including chemical processing equipment, ballistics and surgical implants. Tantalum carbides are used in cutting tools.

Tantalum is also used in medical applications (medical device implants, bone and joint replacements), but with a very low share (<1%).

Relevant industry sectors are described using the NACE sector codes (Eurostat, 2019c).

**Table 198: Tantalum applications, 2-digit and associated 4-digit NACE sectors, and value added per sector (Eurostat, 2019c)**

<b>Applications</b>	<b>2-digit NACE sector</b>	<b>4-digit CPA sectors</b>	<b>Value added of NACE 2 sector (millions €)</b>
Capacitors	C26 - Manufacture of computer, electronic and optical products	C2610- Manufacture of electronic components	65,703
Aerospace	C30 – Manufacture of other transport equipment	C3030- Manufacture of air and spacecraft and related machinery	44,304
Sputtering targets	C26 - Manufacture of computer, electronic and optical products	C2610- Manufacture of electronic components	65,703
Mill products	C25 - Manufacture of fabricated metal products, except machinery and equipment	C2593- Manufacture of tools	148,351
Carbides	C28 – Manufacture of machinery and equipment n.e.c	(C2824-Manufacture of machinery for mining, quarrying and construction)	182,589
Chemicals	C20 – Manufacture of chemicals and chemical products	C2029-Manufacture of other chemical products n.e.c.	105,514

### **25.3.3 Substitution**

Substitutes of tantalum for different applications remain the same as in the years 2010-2014. No major change has been identified.

In capacitors, the vast majority of them in electronic devices do not contain tantalum, mostly because of their high prices. In terms of substitution, niobium (also considered a critical raw material for the EU since 2011) can be used to produce capacitors at lower cost, but they are usually larger and have a shorter life-span. Other alternatives are ceramic capacitors (multilayer

or monolithic) or standard aluminium capacitors (both also have larger size, reduced capacitance and are more sensitive to harsh and hot operating conditions). The superior performance and robustness of tantalum capacitors thus remains the only reliable choice in applications where long term reliability, size and/or security matters (e.g. automobile anti-lock brake systems, airbag activation systems, satellites, etc.).

Tantalum carbides are used in cutting tools. Other refractory metals which share similar properties of strength and resistance at high temperatures can be substitutes for carbides (tungsten, niobium, titanium, molybdenum), although prices are often comparable.

In many types of superalloys tantalum is one of several elements added to the base metal (nickel, cobalt or iron) in small but precise quantities. Substituting tantalum for another element would dramatically alter the properties of the superalloy. Once a particular superalloy has been engineered into an aero engine or industrial gas turbine and approved for commercial use any subsequent change to that superalloy would take many years to become established. Tantalum plays a critical role in superalloys and in this application it is a relatively minor cost, making substitution unlikely.

## **25.4 Supply**

---

### **25.4.1 EU supply chain**

Over the period 2012-2016, there was no production of tantalum in the EU reported in the World Mining Data (WMD, 2019). However, production of tantalum is known to take place by Imerys, in France, producing 5 tonnes of Ta<sub>2</sub>O<sub>5</sub> per year. The production of tantalum in France is all exported (Bourgeois, et. al., 2017). The EU therefore remained highly dependent on its foreign imports, with an import reliance of 100%.

At the processing and manufacturing stage, a small number of processors/manufacturers are present in the EU.

- At the processing stage, capacities are found in Germany and in Estonia (with the company NPM Silmet AS which processes columbite ore coming from Nigeria, to produce REEs, Nb and Ta products).
- Two capacitors manufacturing companies operate in Czech Republic (AVX) and in Portugal (Kemet).
- In the aerospace sector, which is one of the most important, a dozen of superalloys producers are known respectively in, France, Germany, Austria, Italy and Sweden, as well as companies using tantalum-containing superalloys to manufacture turbine blades for jet engines. Roskill estimates that the EU could consume half of tantalum used globally in superalloys (Roskill, 2016).
- Others uses include sputtering targets, another major application for tantalum although less important in the EU. The company H.C. Starck in Germany is a major player in this market, although most of its plants are outside the EU. Other markets such as tantalum carbides, tantalum chemicals and mill products also have EU users, although it is in modest quantities and quite diverse applications.
- EU supply is fed by processed and secondary materials to a large extent. As in the case of most minor metals, the EU hosts many companies active in the trading in Ta minerals and products.

## 25.4.2 Supply from primary materials

### 25.4.2.1 Geology, resources and reserves of tantalum

**Geological occurrence:** Tantalum does not occur in a free state in nature, but in the form of complex oxides and other minerals. Whilst at least nineteen tantalum minerals had been recorded as early as 1982 (Foord, 1982), many of them are only of mineralogical interest. The main ones found in economic quantities are tantalite-columbite, microlite, wodginite and struverite. Tantalum minerals are often associated with cassiterite (the primary source of tin), and such ores are another important source of tantalum.

Tantalite-columbite is an isomorphous series, where tantalum and niobium may substitute with each other. Tantalite is the tantalum-rich end. The common ratios between the two are from 3:1 to 1:3, thus being either tantalo-columbite or columbo-tantalite (which is the most common, also shortened to 'coltan' especially in Central Africa). Microlite is the tantalum-rich end member of the microlite-pyrochlore series. Wodginite is less common, but was the primary tantalum mineral found in the original Wodgina deposit in Australia (from which it gained its name) and also at the Tanco mine in Canada. Struverite, a variation of rutile, is a low grade source of tantalum predominately associated with cassiterite in south-east Asia (Burt, 2016).

All primary tantalum (and niobium) deposits are associated with igneous rocks, and can be grouped into three types, on the basis of the associated igneous rocks:

- Peraluminous pegmatites and granites
- Alkaline to peralkaline granites and syenites
- Carbonatite-hosted deposits

Pegmatites have been, and continue to be, the most important source of tantalum mineralization, although only a very small fraction of pegmatites do contain tantalum. The two main periods where tantaliferous pegmatites were intruded are in the Archaean (>2.5 billion years ago) and the Proterozoic (500-1,400 million years ago) (Burt, 2016). Pegmatites are enriched in aluminium compared to the alkali based minerals (sodium and potassium-rich minerals) (Černý, 1989). Pegmatites are generally relatively small (1-100 million tonnes). They can be 'simple' or 'complex', with several discrete zones within the pegmatite, each zone containing significantly different mineral assemblages. In Central Africa many small pegmatites are found, which have been heavily weathered to the point of kaolinization and have become soft-rock deposits, particularly appropriate for artisanal exploitation.

Alkaline granites are enriched in the alkali based minerals compared to aluminium. They generally occur in rift or failed rift tectonic settings and are often relatively large deposits (100-1,000 million tonnes), with fine mineralogy (Burt, 2016). These rocks typically contain high contents of zirconium and rare earth elements (REEs) minerals. Significant concentrations of niobium and tantalum also occur, with the primary mineral being pyrochlore. A major example is the Pitinga mine in Brazil which is a Paleoproterozoic albite-rich peralkaline granite, exploited for tin, niobium and tantalum.

Syenites are another form of alkali feldspathic rock, with dominant nepheline syenite, generally highly complex. The Lovozero deposit in northern Russia is a prime example of an operating mine where tantalum and niobium are important by-products.

Carbonatites are igneous rocks that contain more than 50% carbonate minerals (calcite, dolomite or ankerite). Most carbonatites occur in rift settings, although several different types exist, many of which are unmineralised. Some can contain anomalous niobium-tantalum

concentrations, along with various rare earth minerals. They are the main sources of niobium extraction.

**Global resources and reserves<sup>268</sup>:** USGS (2019) only indicates that identified resources of tantalum, most of which are in Australia, Brazil, and Canada, are considered adequate to meet projected needs. Some deposits were also identified in the United States, but they were considered uneconomic at 2018 prices for tantalum.

On the global level, data for tantalum reserves from USGS is the only reference available, presented in Table 199. Many major current producing countries are not represented in this reporting, in particular those from Central Africa because of the type of deposits and the fact that artisanal mining operations do not rely on any preliminary resources & reserves assessment.

**Table 199: Global reserves of tantalum (USGS, 2019)**

<b>Country</b>	<b>Reserves (tonnes of Ta)</b>
Australia	76,000 among which 37,000 JORC compliant
Brazil	34,000
Others	N.A
<b>TOTAL</b>	<b>&gt;110,000</b>

**EU resources and reserves<sup>269</sup>:**

Potential resources of tantalum (and niobium) were reported to exist in Finland, France, Portugal, Norway, Sweden, Greenland and Germany with no further evaluation (Minerals4EU,2014). Historic resources estimates are given in Table 200, with only indicative values, as these numbers do not comply with international standards of reporting and are very likely to be overestimated, as well as being uneconomic in current market conditions.

In Portugal, there are knowledge gaps over the hundreds of Portuguese LCT and NYF pegmatites, explored and exploited for ceramic raw materials (quartz and feldspar). There is no formal legal

---

<sup>268</sup> There is no single source of comprehensive evaluations for resources and reserves that apply the same criteria to deposits of tantalum in different geographic areas of the EU or globally. The USGS collects information about the quantity and quality of mineral resources but does not directly measure reserves, and companies or governments do not directly report reserves to the USGS. Individual companies may publish regular mineral resource and reserve reports, but reporting is done using a variety of systems of reporting depending on the location of their operation, their corporate identity and stock market requirements. Translations between national reporting codes are possible by application of the CRIRSCO template.<sup>268</sup>, which is also consistent with the United Nations Framework Classification (UNFC) system. However, reserve and resource data are changing continuously as exploration and mining proceed and are thus influenced by market conditions and should be followed continuously.

<sup>269</sup> For Europe, there is no complete and harmonised dataset that presents total EU resource and reserve estimates for tantalum. The Minerals4EU project is the only EU-level repository of some mineral resource and reserve data for tantalum, but this information does not provide a complete picture for Europe. It includes estimates based on a variety of reporting codes used by different countries, and different types of non-comparable datasets (e.g. historic estimates, inferred reserves figures only, etc.). In addition, translations of Minerals4EU data by application of the CRIRSCO template is not always possible, meaning that not all resource and reserve data for tantalum the national/regional level is consistent with the United Nations Framework Classification (UNFC) system (Minerals4EU 2019). Many documented resources in Europe are based on historic estimates and are of little current economic interest. Data for these may not always be presentable in accordance with the UNFC system. However a very solid estimation can be done by experts.

obligation to follow standard reporting codes (CRIRSCO compliant), making it difficult to gather reliable data on mineral resources and reserves in Portugal (Pereira, 2019).

Potential deposits of tantalum were also identified in south-west Finland, on Kemiö Island<sup>270</sup> discovered by the Geological Survey of Finland (GTK). The Exploration Licence for the project expired in October 2015 and the Company has applied for a renewal of the Licence.

In Spain, Penouta mine has recently been re-opened. The Penouta Mine was one of the most important tin mines in Spain that closed in 1985 without any restoration process. These residues present in this mine contained concentrations of metals, among others tantalum and niobium. Exploration is also ongoing at Alberta II deposit, containing pegmatites ore. The reserves is estimated as 12.3 tonnes with 0.0121% of tantalum pentoxide (Ta<sub>2</sub>O<sub>5</sub>) grade content (Bourgeois, et. al., 2017).

Reserves of tantalum are known to exist also in France, however, the estimated quantity information is confidential (Schwela, 2019).

Minerals4EU (2014) reports no data for tantalum reserves in Europe. In 2019, there has not been any update on Minerals4EU.

**Table 200: Resource data for the EU compiled in the European Minerals Yearbook of Minerals4EU (2019)**

Country	Reporting code	Value	Weighted Average Grade	Code Resource Type
Finland	None	251 Mt	0.0062% Ta <sub>2</sub> O <sub>5</sub>	Historic Resource Estimates
France	None	7,900 t	Ta-Nb content	Historic Resource Estimates
Portugal	None	8.04 Mt	41.79 g/t of ?	Historic Resource Estimates
Norway	None	8.03 Mt	0.995	Historic Resource Estimates
Sweden	Historic	0.6 Mt	80 g/t of ?	Historic Resource Estimates

#### 25.4.2.2 World and EU mine production

The annual world production of tantalum over the period 2012-2016 was estimated at 1,191 tonnes according to the data reported by World Mining Data (2019), shown in Figure 476. Figure 476 also shows a share of EU production that was not reported in World Mining Data.

According to national statistics, the two main producers in the years over 2012-2016 were the Democratic Republic of Congo (33%) and Rwanda (28%) both accounting for more than half of global primary supply. Nevertheless data reported from those two countries are always subject to uncertainties, due to the difficulties of tracing artisanal mining total output despite numerous initiatives to increase transparency (OECD, iTSCi etc.). Brazil accounted for 9% of global production, followed by an important number of smaller players.

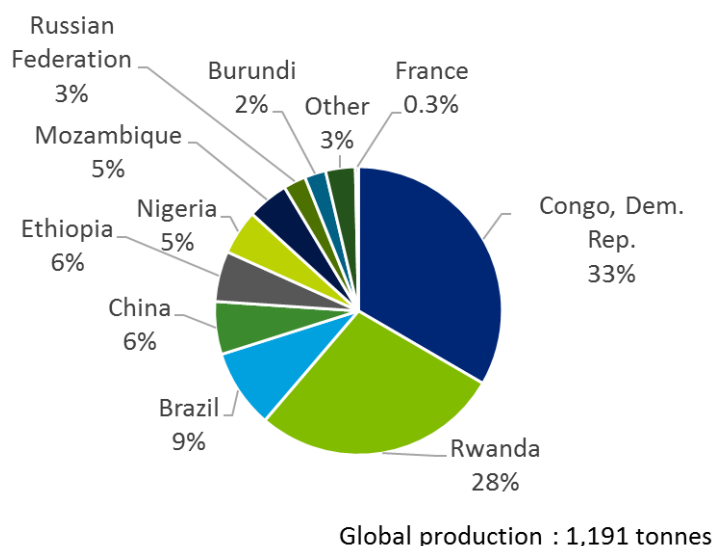
.T.I.C. (2019) estimated the world annual production of tantalum 2012-2016 amounted to 1,580 tonnes of tantalum

<sup>270</sup> <https://www.tertiaryminerals.com/index.php?route=projects/other-projects/rosendal#heading-0>



In 2012-2016, China and Burundi imposed export tax for HS 26159090 "Other", the following products are under this HS code: 2615909010 "Niobium, tantalum concentrates and ores" and HS 2615909090 "Vanadium ores and concentrates". Rwanda applied "fiscal tax on exports" of 4% on HS 261590 "Niobium, Tantalum & Vanadium Ores & Concentrates" for which the tantalum concentrates and ores was included.

Some production of tantalum was reported in France, at 4.9 tonnes of tantalum per year, accounting for 0.3% of global supply over the years 2012-2016.



**Figure 476: Global production of tantalum in tonnes and percentage. Average for the years 2012-2016 (World Mining Data, 2019).**

The Penouta mine is a historic mine containing tantalum, tin and niobium in Spain. In 2018, Strategic Minerals Spain (SMS) started the processing of tailings from waste-rock heaps and ponds of the old Penouta mine leading to the obtaining of tantalum and niobium minerals through a gravimetric separation process, without any chemical products or waste that is harmful to the environment. It is estimated that the mineral resources in the remaining original deposit amount to 95.5 Mt of Measured and Indicated Mineral Resources with average grades of 77 ppm Ta and 443 ppm Sn, and in the old tailing waste-rock heaps where the company has started operations 12 Mt of resources with average grades of 35 ppm Ta and 428 ppm Sn<sup>271</sup>.

### 25.4.3 Supply from secondary materials

The recycling rates for tantalum vary depending on the type of material and stage in the supply chain. At the processor level, it is in company's interest to achieve as high yield as possible (Schwela, 2019).

Tantalum can be recovered from scrap, incineration bottom ash, superalloys, pyrometallurgical slag, and tin slag. Tantalum is commonly extracted from scrap, slags, or scraps through high

<sup>271</sup> Blengini, G.A.; Mathieux, F.; Mancini, L.; Nyberg, M.; Viegas, H.M. (Editors); Salminen, J.; Garbarino, E.; Orveillon, G.; Saveyn, H.; Mateos Aquilino, V.; Llorens González, T.; García Polonio, F.; Horckmans, L.; D'Hugues, P.; Balomenos, E.; Dino, G.; de la Feld, M.; Má dai, F.; Földessy, J.; Mucsi, G.; Gombkötő, I.; Calleja, I. Recovery of critical and other raw materials from mining waste and landfills: State of play on existing practices, EUR 29744 EN, Publications Office of the European Union, Luxembourg, 2019, ISBN 978-92-76-08568-3, doi:10.2760/600775, JRC116131.

temperature digestion in a sulfuric acid, resulting in a highly purified tantalum and niobium (Sundqvist Oeqvist, Pr. Lena et al. ,2018).

The end-of-life recycling input rate of tantalum products is under 1% (UNEP, 2011). Nevertheless, recycling of used items containing tantalum exists, but it is primarily 'pre-consumer', that is from within the upstream supply chain itself, rather than from end-users. In the aeronautic industry for instance, turbine blades are reprocessed. The composition of superalloys is known or can be tested, and the alloys are added to the melt when producing new alloys (Roskill, 2016).

Processor scrap and other secondary materials are also an important part of tantalum supply. Scrap generated during manufacturing, for example of capacitors, is returned to processors. The main source of this recycled material is from the electronics industry (capacitors, sputtering targets, etc.). Estimates from various sources give that about 30% of new demand for tantalum in any year is met from such material, a figure that hardly varied for a few decades (Burt, 2016).

In the EU, various recyclers and processors count tantalum in their activities. Some key actors in tantalum recovery are available in Germany, Estonia, France (from kaolin mining), and Spain (from tin mining). (Sundqvist Oeqvist, Pr. Lena et al. ,2018).

#### **25.4.4 Processing of tantalum**

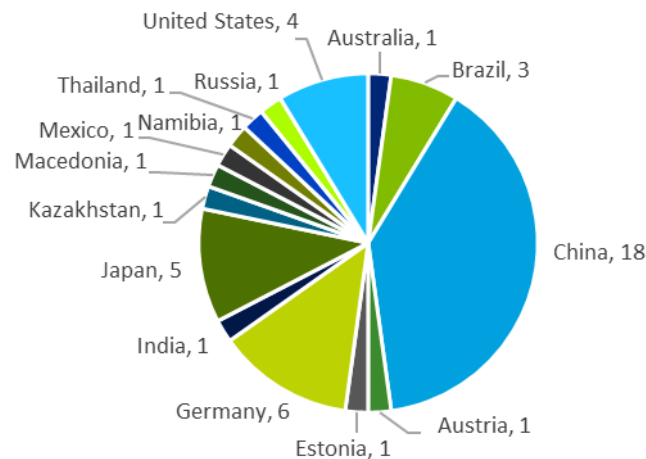
No data was available for global and European production of processed materials (Ta oxides and fluorides). WMD, BGS and USGS reported tantalum production only at the extraction stage. There is no Eurostat trade code for tantalum oxides and fluorides in ProdCom and in Eurostat-Comext.

The world production of intermediate products is not known. T.I.C (2019) reported an estimate of 2,200 tonnes of  $Ta_2O_5$ ,  $K_2TaF_7$ , as well as secondary products are generated each year, equivalent to 1,200 tonnes of tantalum. The top three producers of tantalum processed materials are China, Germany, and the United States. No exact production shares are available (Schwela, 2019).

Even though producing countries are quite diverse at the extraction stage, the next steps of tantalum value chain are more concentrated in Asia.

The International Trade Administration (ITA) reported a list of identified companies known to be the consumers of tantalum ores and concentrates (Figure 477). This list contains global facilities known to be able to process tantalum concentrate to produce industrial tantalum products. According to this list, China was reported to have the highest number of tantalum facilities.

China is the main importer of tantalum concentrates globally, and operates more than half of the "official" 3Ts (tin, tantalum, tungsten) smelters processing tantalum (Figure 477), a number that could have increased. China is also a major exporter of processed Ta-products, to the EU, US and others.



**Figure 477: Identified global consumers of tantalum concentrates in 2018 in number (ITA, 2018)**

## 25.5 Other considerations

### 25.5.1 Environmental and health and safety issues

No environmental restriction is known for tantalum.

### 25.5.2 Socio-economic issues

The Regulation of the European Parliament and of the Council sets up a Union system for supply chain due diligence self-certification in order to curtail opportunities for armed groups and unlawful security forces to trade in tin, tantalum and tungsten, their ores, and gold. It will take effect on 1 January 2021. It is designed to provide transparency and certainty as regards the supply practices of importers, (notably smelters and refiners) sourcing from conflict-affected and high-risk areas. The EU regulation covers tin, tantalum, tungsten and gold, because these are some of the minerals that are most often linked to armed-conflicts and related human rights abuses<sup>272</sup>.

The Regulation requires importers to follow a five-step framework which the Organisation for Economic Co-operation and Development (OECD) has laid out in a document called 'Due Diligence Guidance for Responsible Supply Chains from Conflict-Affected and High-Risk Areas' (OECD Guidance).

The regulation only applies directly to EU-based importers of tin, tantalum, tungsten and gold, whether these are in the form of mineral ores, concentrates or processed metals.

In addition to the conflict minerals issue, approximately 20 to 25% of mined tin and tantalum are produced by artisanal and small-scale mining (ASM). ASM often operates outside health, safety and environmental legislation, therefore is characterised by vulnerability (limited capacity to cope with shocks and hazard) and marginalisation (as it is usually practised in remote areas, with limited access to markets) (RMIS, 2019).

<sup>272</sup> [https://ec.europa.eu/trade/policy/in-focus/conflict-minerals-regulation/index\\_en.htm](https://ec.europa.eu/trade/policy/in-focus/conflict-minerals-regulation/index_en.htm)

## 25.6 Comparison with previous EU assessments

---

The assessment has been conducted using the same methodology as for the 2017 list. The supply risk of tantalum was assessed based on global supply concentration at mine stage. The results of this and earlier assessments are shown in Table 201.

**Table 201: Economic importance and supply risk results for tantalum in the assessments of 2011, 2014, 2017, 2020 (European Commission, 2011; European Commission, 2014; European Commission, 2017)**

Assessment	2011		2014		2017		2020	
Indicator	EI	SR	EI	SR	EI	SR	EI	SR
Tantalum	7.4	1.1	7.4	0.6	3.9	1.0	3.9	1.36

The end-use application of tantalum in the EU has not changed since the criticality assessment 2017. Although there has been a change in value added in the sectors for which tantalum was relevant, the economic importance of tantalum remained the same as the results from criticality assessment 2017.

The supply risk of tantalum showed a higher value in comparison to the result from criticality assessment 2017. The only known EU domestic production of tantalum between 2012-2016 from France was exported. The EU relied exclusively on import to meet its demand.

The figure from World Mining Data showed a global increasing trend in the production of tantalum, especially with the contribution of countries with high WGI value like Democratic Republic of Congo (33% of global production share). The global production of tantalum became more concentrated in countries with high WGI values and this was reflected in higher supply risk value.

## 25.7 Data sources

---

Information on country by country production is only available for tantalum ores and concentrates at the global level. However, such information is still relatively opaque due to the fact that a great part is coming from artisanal mining, and that the global market is small (2,000 tonnes) (European Commission, 2017). In Eurostat Comext, the trade data on tantalum ores and concentrates refers to the trade code 261590: Niobium, tantalum, or vanadium ores and concentrates. However, Comext returned empty tables for import and export.

The data on the EU import of tantalum was provided by Tantalum-Niobium International Study Center (T.I.C.). T.I.C. uses another approach to build supply statistics; primary production estimates rely on declaration of shipments to processors, which allows summing all materials at the global level but do not give any indication of the origin of products. Traceability of individual producers is lost at this level. Furthermore, the same applies for processed materials which are grouped by categories (capacitor-grade Ta powders, Ta chemicals, Ta carbides, etc.) and summed at the global level in a similar way. It is even more difficult to trace origins for these intermediary products, as customs codes are even more diverse and sometimes wrongly classified (European Commission, 2017).

### 25.7.1 Data sources used in the factsheet

Bio Intelligence Service (2015). Study on Data for a Raw Material System Analysis, Background data supplied.

Blengini, G.A.; Mathieux, F.; Mancini, L.; Nyberg, M.; Viegas, H.M. (Editors); Salminen, J.; Garbarino, E.; Orveillon, G.; Saveyn, H.; Mateos Aquilino, V.; Llorens González, T.; García Polonio, F.; Horckmans, L.; D'Hugues, P.; Balomenos, E.; Dino, G.; de la Feld, M.; Má dai, F.; Földessy, J.; Mucsi, G.; Gombkötő, I.; Calleja, I. Recovery of critical and other raw materials from mining waste and landfills: State of play on existing practices, EUR 29744 EN, Publications Office of the European Union, Luxembourg, 2019, ISBN 978-92-76-08568-3, doi:10.2760/600775, JRC116131.

Bourgeois, Florent, Eugen Andreiadis, and Jean-marie Lambert. (2017). "Tantalum and Niobium Production State of the Art." (March): 9–10.

Burt, R.O. (2016). Much ado about Tantalum. Again. Technical paper, pp.12 [online] Available at: <http://www.tanb.org/about-tantalum/tantalum-further-information>

Černý, P. (1989). Characteristics of Pegmatite Deposits of Tantalum. In Lanthanides, Tantalum, and Niobium, edited by P. Möller, P. Černý, and F. Saupé. Springer-Verlag, Berlin, p.195-239.

DERA (2019). Mineral Price Monitor. [https://www.deutsche-rohstoffagentur.de/SharedDocs/GT\\_Produnkte/Mineral\\_Rohstoffe/volatilitaetsmonitor\\_allergenTab\\_DE.html?nn=5091242](https://www.deutsche-rohstoffagentur.de/SharedDocs/GT_Produnkte/Mineral_Rohstoffe/volatilitaetsmonitor_allergenTab_DE.html?nn=5091242)

European Commission (2011). Critical raw materials for the EU. [online] Available at: [https://ec.europa.eu/growth/sectors/raw-materials/specific-interest/critical\\_en](https://ec.europa.eu/growth/sectors/raw-materials/specific-interest/critical_en)

European Commission (2014)a. Report on Critical Raw Materials for the EU. [online] Available at: [https://ec.europa.eu/growth/sectors/raw-materials/specific-interest/critical\\_en](https://ec.europa.eu/growth/sectors/raw-materials/specific-interest/critical_en)

European Commission (2017). Report on Critical Raw Materials for the EU. Critical Raw Materials Profiles [online] Brussels European Commission, Available at: <http://ec.europa.eu/growth/sectors/raw-materials/specific-interest/critical/>

European Commission (2016a). DG Trade. Agreements [online] Available at: <http://ec.europa.eu/trade/policy/countries-and-regions/agreements/>

European Commission (2016b). DG Trade. In focus: Conflict minerals. The regulation explained [online] Available at: <http://ec.europa.eu/trade/policy/in-focus/conflict-minerals-regulation/regulation-explained/>

Eurostat (2019)c. Annual detailed enterprise statistics for industry (NACE Rev. 2, B-E). [online] Available at: [http://ec.europa.eu/eurostat/en/web/products-datasets/-/SBS\\_NA\\_IND\\_R2](http://ec.europa.eu/eurostat/en/web/products-datasets/-/SBS_NA_IND_R2)

European Parliament (2016). Conflict minerals: MEPs secure mandatory due diligence for importers. Press release - External/international trade – November 2016 [online] Available at: <http://www.europarl.europa.eu/news/en/news-room/20161122IPR52536/conflict-minerals-meps-secure-mandatory-due-diligence-for-importers>

Foord, E.E. (1982). Minerals of tin, titanium niobium and tantalum in granitic pegmatites. Černý, P Ed. Short Course in Granitic Pegmatites in Science and Industry Mineralogical Association of Canada, Winnipeg. pp187-238.

Euromines (2019). Personal communication, October 2019.

International Trade Administration (ITA) (2018). List of identified global consumers of tantalum concentrates 2018. Available at: [www.trade.gov/industry/materials/FINAL\\_Tantalum\\_2018%20TG\\_10-30-18.pdf](http://www.trade.gov/industry/materials/FINAL_Tantalum_2018%20TG_10-30-18.pdf)

Minerals4EU (2019). European Minerals Yearbook. [online] Available at: [http://minerals4eu.brgm-rec.fr/m4eu-yearbook/theme\\_selection.html](http://minerals4eu.brgm-rec.fr/m4eu-yearbook/theme_selection.html)

Monnet, A., Abderrahim, A.A. (2018). Report on major trends affecting future demand for critical raw materials. SCREEN D2.2. Available online at: <http://www.screen.eu/wp-content/uploads/2018/07/D2.2-Report-on-major-trends-affecting-future-demand-for-critical-raw-materials.pdf>

OECD (2019). Export restrictions on Industrial Raw Materials. [online] Available at: [http://qdd.oecd.org/table.aspx?Subject=ExportRestrictions\\_IndustrialRawMaterials](http://qdd.oecd.org/table.aspx?Subject=ExportRestrictions_IndustrialRawMaterials) [Accessed September 2019]

Pereira, Bruno (2019). Personal communication, September 2019. OECD (2014). List of 3T smelters. [online] Available at: <https://www.oecd.org/daf/inv/mne/3TsSmelterList.pdf>

Raw Materials Information System (RMIS) (2019). Artisanal and Small Scale-Mining. Available at: <http://139.191.177.97/?page=artisanal-and-small-scale-mining-a6f8a3>

Roskill (2016). EU Tantalum Sector Overview. Roskill Information Services Ltd., London, UK. p.11

Roskill (2018). Tantalum/Niobium: H.C. Starck Sells Its Tantalum/Niobium Business Unit to Customer. [online] <https://roskill.com/news/tantalum-niobium-h-c-starck-sells-tantalum-niobium-business-unit-customer/> access date 30/01/2020

Rudnick, R.L. and Gao, S. (2003). Composition of the Continental Crust. In: Treatise on Geochemistry, Volume 3. Editor: Roberta L. Rudnick. Executive Editors: Heinrich D. Holland and Karl K. Turekian. pp. 659. ISBN 0-08-043751-6. Elsevier, p.1-64.

SCREEN workshop. (2019). "Validation Workshop on Critical Raw Materials, 10-12 September 2019, Thon Hotel Brussels City Centre."

Schwela, Ulric (2019). Personal communication, September 2019.

Sundqvist Oeqvist, Pr. Lena et al. (2018). SCREEN D4.2. Production Technologies of CRM from Primary Resources. Available at: <http://screen.eu/wp-content/uploads/2018/03/SCREEN-D4.2-Production-technologies-of-CRM-from-secondary-resources.pdf>

Tantalum-Niobium International Study Center (T.I.C) (2019). Tantalum-Niobium International Study Center. Personal communication with David Knudson and Roland Chavasse.

UNEP (2011). Recycling Rates of Metals. A Status Report, A Report of the Working Group on the Global Metal Flows to the International Resource Panel, United Nations Environment Programme, [online] Available at: <http://web.unep.org/publications/>

USGS. (2019). Tantalum - Mineral Commodity Summaries. United States Geological Survey. Ed., Washington DC, pp.2

World Mining Data (2019). Bundesministerium für Nachhaltigkeit und Tourismus. Austrian Federal Ministry of Sustainability and Tourism [online] Available at: <http://www.en.bmwfw.gv.at/Energy/WorldMiningData/Seiten/default.aspx>

## 25.7.2 Data sources used in the criticality assessment

European Commission (2016a). DG Trade. Agreements [online] Available at: <http://ec.europa.eu/trade/policy/countries-and-regions/agreements/>

European Commission (2017). Report on Critical Raw Materials for the EU. Critical Raw Materials Profiles [online] Brussels European Commission, Available at: <http://ec.europa.eu/growth/sectors/raw-materials/specific-interest/critical/>

Bourgeois, Florent, Eugen Andreiadis, and Jean-marie Lambert. (2017). "Tantalum and Niobium Production State of the Art." (March): 9–10.

Graedel, and E. M. Harper. (2015). By-Product Metals Are Technologically Essential but Have Problematic Supply. *Science Advances*. <https://doi.org/10.1126/sciadv.1400180>.

OECD (2019). Export restrictions on Industrial Raw Materials. [online] Available at: [http://qdd.oecd.org/table.aspx?Subject=ExportRestrictions\\_IndustrialRawMaterials](http://qdd.oecd.org/table.aspx?Subject=ExportRestrictions_IndustrialRawMaterials) [Accessed September 2019]

J. K. Tiesn and T Caulfield (Eds). *Superalloys, supercomposites and superceramics*

Kemet (2008). Technical Update-Comparison of Ceramic and Tantalum Capacitors. [online] Available at: <http://www.kemet.com/Lists/TechnicalArticles/Attachments/93/2008-11%20Update%20-%20Ceramic%20versus%20Tantalum.pdf>

Kurylak, Witold, Ulla-Maija Mroueh, Susanna Casanovas, Rocio Barras Garcia, Santiago Cuesta, and Katarzyna Leszczynska-Sejda (2016). Mapping the Secondary Resources in the EU (Urban Mines).

Lesker (2016). Tantalum Sputtering Targets. J. Lesker Company. [online] Available at: [http://www.lesker.com/newweb/deposition\\_materials/depositionmaterials\\_sputtertargets\\_1.cfm?pgid=ta1](http://www.lesker.com/newweb/deposition_materials/depositionmaterials_sputtertargets_1.cfm?pgid=ta1) Nassar, N. T., T. E. Graedel, and E. M. Harper (2015). By-Product Metals Are Technologically Essential but Have Problematic Supply. *Science Advances*. <https://doi.org/10.1126/sciadv.1400180>.

Schwela, Ulric (2019). Personal communication, September 2019.

SCRREEN workshop. (2019). "Validation Workshop on Critical Raw Materials, 10-12 September 2019, Thon Hotel Brussels City Centre."

Tercero, L., Stotz, H., Otmar Deubzer, García, R. B., Lepe, G. R., Bilewska, K., ... Hu, X. (2018). SCRREEN D5.1 Critical Raw Material substitution profiles. In SCRREEN - D5.1. Retrieved from <http://screen.eu/wp-content/uploads/2018/05/SCRREEN-D5.1-CRM-profiles.pdf>

Tantalum-Niobium International Study Center (T.I.C) (2019). Tantalum-Niobium International Study Center. Personal communication with David Knudson and Roland Chavasse.

World Mining Data (2019). Bundesministerium für Nachhaltigkeit und Tourismus. Austrian Federal Ministry of Sustainability and Tourism [online] Available at: <http://www.en.bmwfw.gv.at/Energy/WorldMiningData/Seiten/default.aspx>

## **25.8 Acknowledgments**

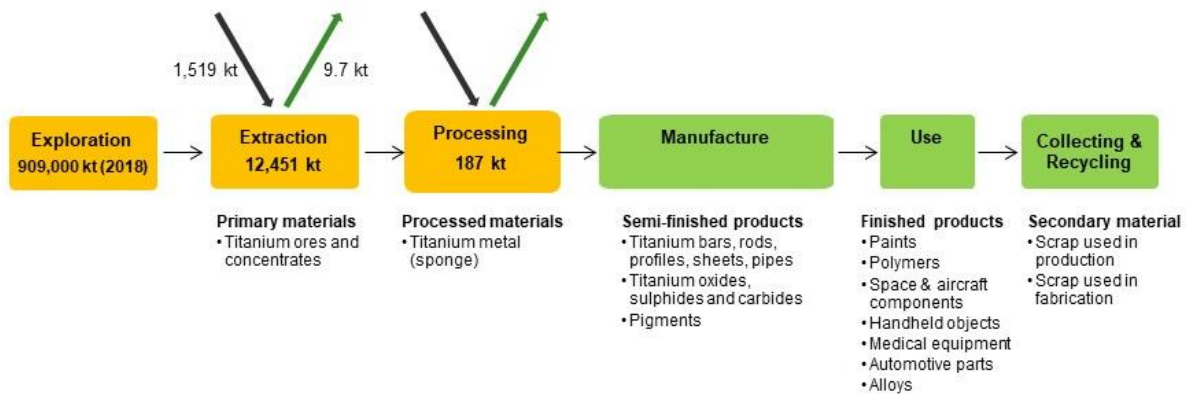
---

This factsheet was prepared by the JRC. The authors would like to thank SCRREEN expert network, the EC Ad Hoc Working Group on Critical Raw Materials and all other relevant stakeholders for their contributions to the preparation of this Factsheet.



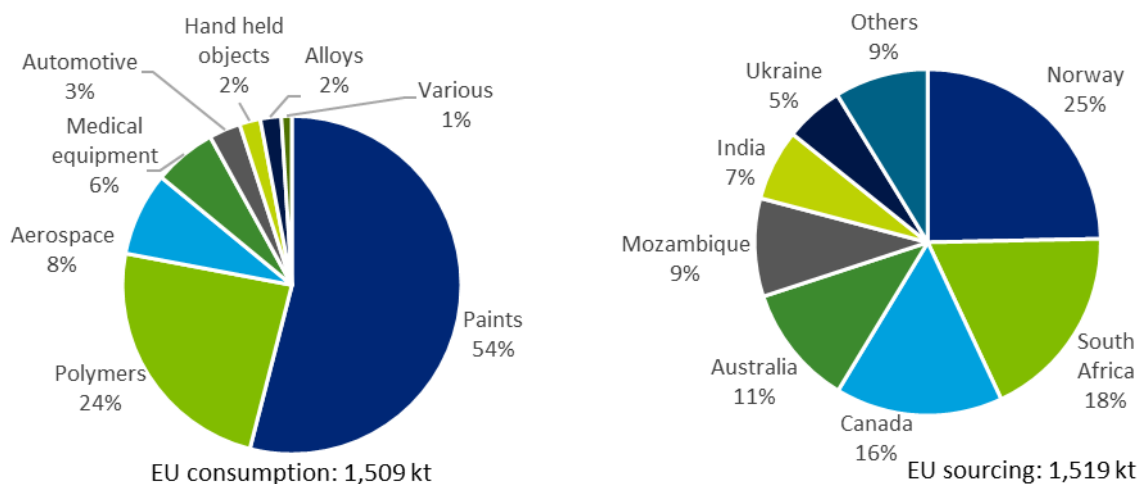
# 26 TITANIUM

## 26.1 Overview



**Figure 478: Simplified value chain for titanium for the EU (average 2012-16)** <sup>273</sup>

Titanium is a chemical element with symbol Ti and atomic number 22. Titanium is a lustrous-white metal of low density (4.51 g/cm<sup>3</sup>) with high mechanical strength. The light metal has a high melting point (1,668°C). Its boiling point is 3,500°C. Despite its high melting point, titanium is not suitable for high temperature applications, since its mechanical strength drops sharply when the temperature exceeds 426°C. Titanium is affected by hydrofluoric acid and hot acids, but it is resistant to diluted, cold hydrochloric acid and sulphuric acid, and to nitric acid up to 100°C in every concentration. Pulverized titanium, formed by various cutting processes, is pyrophorus: it ignites spontaneously in air at or below 55°C. The range of applications using titanium widened as a result of transport equipment inventions (i.e. titanium alloys used in gas turbines engines) during the 20<sup>th</sup> century, although the most common compound of titanium is used for pigments.



**Figure 479: EU end uses and EU sourcing (mine stage) of titanium, average 2012-2016 (BGS, 2019; Eurostat, 2019a)**

Titanium production falls into two categories: the production of ores and concentrates and the production of titanium metal. Titanium sponge metal is a porous, brittle form of titanium, a

<sup>273</sup> JRC elaboration on multiple sources (see next sections)

highly ductile metal which has a high strength-to-weight ratio. Sponge is an intermediate product used to produce titanium ingot, which in turn is used to make slab, billet, bar, plate, sheet, and other titanium mill products (Reade, 2019).

The trade code used in this assessment is for the titanium ores and concentrates: HS2,4,6 and CN8, (26140000) "Titanium ores and concentrates". For Titanium metal sponge there are no trade codes available from Eurostat Comext (2019).

Prices of titanium ores and concentrates and of titanium final products are strongly linked to their applications demand. Titanium prices rose steadily between the late 1970s and the late 1980s (see Figure 482). From 1971 to 1981, titanium price rose by 80% due to a growing demand from military and civil aviation industries. Titanium prices stayed at a high level with minor fluctuations until early 2000s, before decreasing with the global economic crisis. In the 2010s, the prices started rising again mainly due to the increasing demand from civil aviation and the industrial sector (DERA, 2019).

The EU consumption of titanium ores and concentrates is around 1,509 kt, which is mainly sourced through Norway, South Africa and Canada (Eurostat, 2019a). There is no domestic production in Europe and thus the EU totally depends on imports. Unfortunately, there is no reliable data and information available for the respective situation when it comes to titanium metal imports.

The main end-uses of titanium are paints, and polymers (manufacture of plastics), (Figure 479), while it has major applications as a metal in aerospace, automotive industry and in medical equipment manufacturing. Titanium's light weight results in better performance with lower fuel consumption when used in transportation, aerospace and other related industries. The major market for titanium dioxide is inorganic pigments, so-called 'titanium white' which uses approximately 54% of all titanium. The aeronautics sector largely dominates demand of titanium metal in Europe, followed by industrial applications and more marginally military applications and consumer goods (BRGM, 2017). Titanium metal has a distinct tendency to build a passive film of  $TiO_2$ , which leads to a high corrosion resistance for the metal. Hence titanium and its alloys are used in chemical, petrochemical plants and in seawater. This passive layer also leads to a good toleration of titanium by human tissue, and due to its non-toxic nature, titanium is used for implants, pins for fixing broken bones and heart pacemaker capsules(Enghag, 2004)(Reade 2019).

In pigments, talc, kaolin and calcium carbonate can partially substitute  $TiO_2$  but not in big amounts. Zinc oxide could also be added for white pigments in paints, being a cheaper solution., , Titanium dioxide is also produced synthetically from titanium slag, which is extracted by a metallurgical process in which iron is extracted from ilmenite or titanomagnetites. Finally, aluminium alloys with rare earth elements (e.g. Scandium) can be substituted for space applications.

Titanium is usually found in bearing minerals such as anatase, ilmenite, and rutile. Ilmenite accounts for about 89% of the world's consumption of titanium minerals. Estimated world resources of ilmenite, rutile, and anatase might even add up to more than 2,000 million t (USGS, 2019). The identified world reserves are estimated to approximately 940 million t of titanium in ilmenite and rutile. The EU resources of titanium are located in Finland and Sweden and amount to 1.800 kt of  $TiO_2$  content. The EU reserves are located in Slovakia and amount to 68 kt (Minerals4EU 2019).

The global production for ores and concentrates is estimated at 12,451 kt per year on average over a period between 2012 and 2016 (BGS, 2019). Canada (19%), China (15%), Australia (13%) and South Africa (12%) are the world's top producers (BGS, 2019). The respective

production for titanium metal between 2012 and 2016 was approximately 187,240 kt per year (USGS, 2019). China (44.5%), Russia (22%) and Japan (22%) lead the global market, followed by just a handful of countries, namely Kazakhstan, Ukraine and India (USGS, 2019). Production of titanium metal increased in 2018 along the entire supply chain. China remains the world's largest producer, both in terms of capacity and output (Roskill, 2019). There is no recorded production within the EU Member states, whereas in Europe generally, Norway is responsible for the production of 756 kt (6% of global production) per year on average over 2012 to 2016.

When it comes to secondary production, old and new scrap are recycled and used in the steel industry and super-alloy industry (Newman, 2015).

## **26.2 Market analysis, trade and prices**

---

### **26.2.1 Global market**

Based on application, the global titanium market can be classified into aerospace & marine, industrial, medical, energy, pigments, additives and coatings, papers & plastics and others. Titanium properties make it an ideal metal to use in aircrafts, armor plating, naval ships, space crafts and missiles. Titanium dioxide accounts for at least half of all pigment sales in the world according to BASF (PCI, 2015). Other compounds, organic and inorganic, are used with TiO<sub>2</sub> to impart different tints (Roskill, 2019).

Based on geography, the global titanium market can be classified into Asia Pacific, Europe, North America, Latin America, and Middle East & Africa (TMR, 2016). North America and Europe are the major markets for titanium, led by the upturn in growth of aerospace and marine industry. Companies in Asia-Pacific and Latin America are investing more in research and development due to properties of titanium such as has low density, high strength and high resistant to corrosion, which have led to demand for titanium in the respective local markets.

Major players operating in the global titanium dioxide market are Huntsman International, Ineos, Iluka Resources Ltd, Sumitomo Corporation, VSMPO, Toho Titanium Co., RTI International Metals, Allegheny Technologies Incorporated and others (TMR, 2016). When it comes to titanium metal, companies such as TIMET, VSMPO, ATI, Arconic, Kobe Steel, Toho Titanium Co. and Baoji Titanium Industry hold a significant portion of global smelting capacity between them and there is a high degree of downstream integration into the production of mill products (Roskill, 2019). Evidently, the titanium market experiences intense competition.

### **26.2.2 Outlook for supply and demand**

Production of titanium increased in 2018 along the entire supply chain (Roskill, 2019). Though the majority of titanium ends up in pigments, plastics and polymers in the form of titanium dioxide, other industrial applications of titanium are rising significantly as well. Demand tends to be more variable, often linked to one-off projects, but growth is expected in the short term, particularly within the chlorine and terephthalic acid markets. The power generation market is also an important consumer of titanium; this metal has been proven by the power industry to be the most reliable of all surface condenser tubing materials (Cooper and Whitley, 1987). Furthermore, titanium alloys are used for advanced steam turbine blades. The advantages are weight reduction, (56% the density of 12% chromium (stainless) steel), and corrosion resistance. Smaller end uses, such as in orthopaedic and dental implants, are also expected to show healthy growth (Roskill, 2019).

In the years 2012 to 2016, supply remains at the same levels or is slightly decreasing (BGS, 2019). Nevertheless, this does not seem to affect the increasing demand nor is the supply balance disrupted.

The European and the North American markets are the ones with the highest demand, mainly due to the use of titanium in aerospace applications. There is a trend towards increased intensity of titanium use in aircraft driven in part by its compatibility with the composite materials being used in airframes (Roskill, 2019). Boeing and Airbus make extensive use of titanium composites in their fuselages and have correspondingly high titanium loadings. Demand increases in the Asian market as well, given the steadily growing Chinese and Indian domestic markets.

**Table 202: Qualitative forecast of supply and demand of titanium**

Material	Criticality of the material in 2020		Demand forecast			Supply forecast		
	Yes	No	5 years	10 years	20 years	5 years	10 years	20 years
Titanium	X		+	+	?	+	?	?

### 26.2.3 EU trade

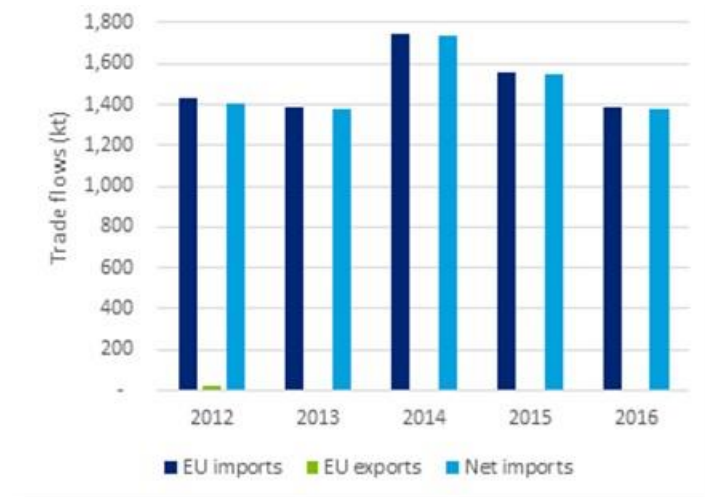
The volumes of imports and exports of titanium to and from the EU have been more or less stable in 2012-2016, generally following macroeconomic trends (Figure 480).

The EU countries do not produce any titanium and thus are importing from all over the world. In fact, the EU imports amount for 1,519 kt on average per year over a period from 2012 to 2016 (Eurostat, 2019a). Norway with 25%, South Africa with 18%, Canada with 16% and Australia with 11% are the major suppliers for the countries of the European Union.

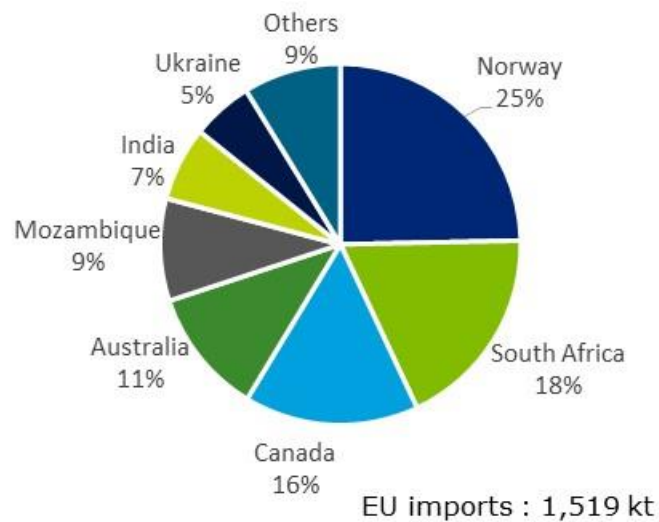
EU imports outweigh exports for titanium ores and concentrates. With the exception of an increase in imports in 2014, the trade statistics reported by (Eurostat, 2019a) show that imports are more or less steady within the period of the assessment. The countries of origin of these imports are shown in Figure 481.

EU is also exporting titanium ores and concentrates though to a much smaller extent. Over the period from 2012 to 2016, the EU countries have exported almost 9.7 kt of titanium ores and concentrates, mostly to Mexico (3.98 kt), Brazil (2.32 kt) and the US (690 kt). Apparently the majority of titanium ores and concentrates that enter Europe are processed, refined and commercialised within the European market. However, when interpreting these trade figures, there are uncertainties about the possible "Rotterdam effect", i.e. some countries re-exports titanium ores and concentrates.

As regards the most important export restrictions in place in 2018, China, India and Sierra Leone impose export taxes from 0% to 25% for titanium ores and concentrates, while Vietnam applies 25% to 75% export taxes respectively (OECD, 2019). These export taxes apply not only to Europe but also to the rest of the world



**Figure 480: EU trade flows for titanium ores and concentrates (2012-2016) (Eurostat, 2019a)**



**Figure 481: EU imports of titanium ores and concentrates. Average 2012-2016 (Eurostat, 2019a)**

Unfortunately, there is no data available and/or reliable enough when it comes to the imports and exports of titanium metal in the EU. In addition there is limited to no reliable data and information about the imports and exports of other countries in other continents outside of Europe.

#### 26.2.4 Prices and price volatility

Titanium is expensive despite the fact that it is the 7<sup>th</sup> most abundant metal and the 9<sup>th</sup> most abundant element overall on the earth's crust. Just about every piece of igneous rock contains it, but it's not easy to extract.

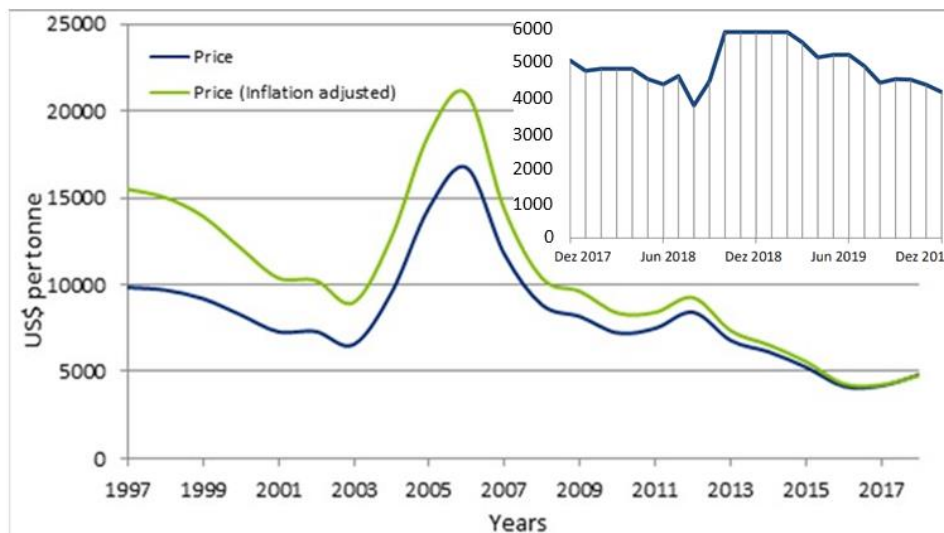
There are two ways to figure out the price of this metal. Most of the titanium ore (95% to be exact) is used to create titanium dioxide (TiO<sub>2</sub>), which is a white pigment used as an additive or coating. Hence, by checking the price of the dioxide we can determine the price of the metal. Then there's the price of titanium metal and alloys. While like other commodities titanium metal

is subject to price movements. When adjusted for inflation the price has generally tended downwards.

Historically there has been volatility in the prices of titanium, depending on the different market trends and the new applications in which titanium was used. Figure 482 shows that real titanium prices rose steadily between the late 1970s and the late 1980s. From 1971 to 1981, titanium price rose by 80% due to a growing demand from military and civil aviation industries. Titanium prices stayed at a high level with minor fluctuations until early 2000s, before decreasing with the global economic crisis.



**Figure 482: Global developments in price of titanium (DERA, 2013).**



**Figure 483. Titanium prices trend (1997-2019) and comparison with prices when inflation is adjusted (in USD/tonne of titanium). (DERA, 2019)**

Trend in recent years are an indication of price volatility. What can be seen clearly is a trend of significantly declining prices since 2006, mostly due to the economic crisis that affected the metals industry as well. While the price in 2006 was USD 21,000 per tonne, in 2018 the price was just USD 4,800.

Respectively, the prices of concentrates dropped dramatically as well. The average price of ilmenite concentrate (> 54% TiO<sub>2</sub>) on the Northern European markets between 2012 and 2015

was 210 USD per tonne (DERA, 2019). According to the DERA raw materials price monitor titanium material prices have increased since 2016 as:

- Ilmenite concentrates cost 105 USD per tonne on average in the period 2015 - 2016 but USD 180 per tonne on average in the period October 2018 – September 2019, i.e. a rising price of 71%.
- Rutile concentrates cost USD 711 per tonne on average in the period 2015-2016 but USD 1229 per tonne on average in the period October 2018 – September 2019, i.e. a rising price of 73%.
- Titanium oxide cost USD 2,239 per tonne on average in the period 2015-2016 but only USD 2,768 per tonne on average in the period October 2018 – September 2019, i.e. a rising price of 24%.

## **26.3 EU demand**

---

### **26.3.1 EU consumption**

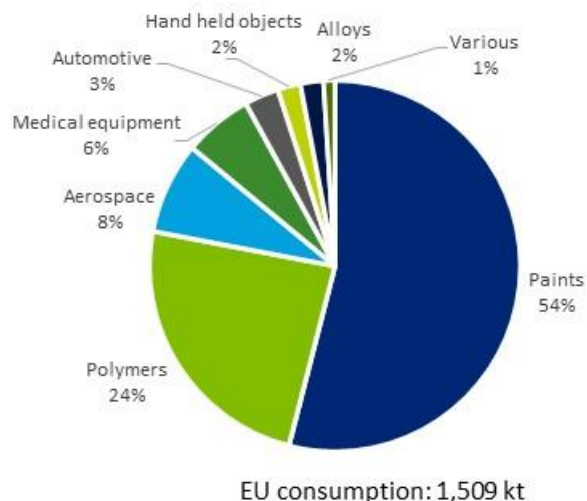
In the period 2012-2016, the EU consumes an average of 1,509 kt of titanium per year. This volume refers to actual titanium content in the ores and concentrates. Global trading activities are only to a limited part undertaken within the EU, given a small export volume of around 9.67 kt, the majority of which is exported to Mexico and Brazil (Eurostat, 2019a). This is in line with the large numbers of countries supplying titanium ores and concentrates.

### **26.3.2 Uses and end-uses of titanium in the EU**

The end uses of titanium products in the EU are demonstrated in Figure 484.

Titanium serves a range of industrial markets due to its remarkable properties, like its low weight, high mechanical strength, high melting point, and small thermal expansion, that make titanium and titanium alloys important for many applications, e.g. for aircraft industries or for medical purposes.

The main end-uses of titanium are paints, and polymers (manufacture of plastics), while it has major applications as a metal in aerospace, automotive industry and in medical equipment manufacturing. Titanium's light weight results in better performance with lower fuel consumption when used in transportation, aerospace and other related industries. The major market for titanium dioxide is inorganic pigments, so-called 'titanium white' which uses approximately 54% of all titanium. The aeronautics sector largely dominates demand of titanium metal in Europe, followed by industrial applications and more marginally military applications and consumer goods (BRGM, 2017). Titanium metal has a distinct tendency to build a passive film of  $TiO_2$ , which leads to a high corrosion resistance for the metal. Hence titanium and its alloys are used in chemical, petrochemical plants and in seawater. This passive layer also leads to a good toleration of titanium by human tissue, and due to its non-toxic nature, titanium is used for implants, pins for fixing broken bones and heart pacemaker capsules (Enghag, 2004)(Reade 2019). Titanium metal has a distinct tendency to build a passive film of  $TiO_2$ , which leads to a high corrosion resistance for the metal. Hence titanium and its alloys are used in chemical plants and in seawater. This passive layer also leads to a good toleration of titanium by human tissue, and titanium is used for implants, pins for fixing broken bones and heart pacemaker capsules. (Enghag, 2004).



**Figure 484: End uses and EU consumption, average 2012-2016 (TNO 2015)(SCREEN workshops 2019)(Eurostat Comext 2019)**

Some titanium alloys can be used at working temperatures up to 600°C. Titanium is lighter than steel, and titanium alloys are stronger than aluminium alloys at elevated temperatures. Due to their high tensile strength to density ratio, high corrosion resistance, and ability to withstand moderately high temperatures without creeping, titanium alloys are used in aircraft, armor plating, naval ships, spacecraft, and missiles. For these applications titanium alloyed with aluminium, vanadium, and other elements is used for a variety of components including critical structural parts, fire walls, landing gear, exhaust ducts (helicopters), and hydraulic systems. In fact, about two thirds of all titanium metal produced is used in aircraft engines and frames (Reade 2019). Titanium nitride and titanium carbide are used to improve the wear characteristics and to prolong the tool life. These materials, also known as hardmetals are used for the manufacturing of cutting tools (Uhlmann 2001) (TNO 2015).

Relevant industry sectors are described using the NACE sector codes in Table 203.

**Table 203: Titanium applications, 2-digit and examples of associated 4-digit NACE sectors, and value-added per sector (average 2012-2016) (Eurostat, 2019b)**

Applications	2-digit NACE sector	Value-added of NACE 2 sector (M€)	Examples of 4-digit NACE sectors
Paints	C20 - Manufacture of chemicals and chemical products	105,514	C20.30 - Manufacture of paints, varnishes and similar coatings, printing ink and mastics
Polymers	C22 - Manufacture of rubber and plastic products	75,980	C22.22 - Manufacture of plastic packing goods
Aerospace	C30 - Manufacture of other transport equipment	44,304	C3030 - Manufacture of air and spacecraft and related machinery
Medical equipment	C28 - Manufacture of machinery and equipment n.e.c.	182,589	C28.99 - Manufacture of other special-purpose machinery n.e.c.
Automotive	C29 - Manufacture of motor vehicles, trailers and semi-trailers	160,603	C29.32 - Manufacture of other parts and accessories for motor vehicles



Hand held objects	C25 - Manufacture of fabricated metal products, except machinery and equipment	148,351	C25.73 - Manufacture of tools
Alloys	C24 - Manufacture of basic metals	55,425	C24.45 - Other non-ferrous metal production
Various	C21 - Manufacture of basic pharmaceutical products and pharmaceutical preparations	80,180	C21.10 -Manufacture of basic pharmaceutical products

### 26.3.3 Substitution

Due to the outstanding properties of titanium, only few materials can compete with its strength-to-weight ratio and corrosion resistance. When a good corrosion resistance is necessary, titanium can be substituted by aluminium, nickel, specialty steels or zirconium alloys (Tercero Espinoza et al, 2013) (USGS 2019). For applications where high strength is required, titanium competes with superalloys, steel, composites, aluminium and intermetallics (USGS 2019).

As a white pigment, titanium dioxide can in some cases be replaced by calcium carbonate, kaolin or talc (USGS 2019). Studies have been undertaken to replace TiO<sub>2</sub> pigment by various percentages of calcined clays in two latex paint formulations. Properties such as thixotropy ("becoming liquid when being put under stress, being shaken), film brightness, scrub resistance, and weather resistance are important to be substituted (Narayan and Raju, 1999).

## 26.4 Supply

### 26.4.1 EU supply chain

The EU relies for the supply of titanium for 100% on its imports. Norway is the major source of titanium for the European Union. The total supply is approximately 1,519 kt on average over 2012 to 2016 coming from more than 20 countries around the world. Imports from Norway are approximately 25%, while South Africa, Canada and Australia cover 18%, 16% and 11% of the EU sourcing for titanium ores and concentrates respectively. There is no available data or information with regard to the EU sourcing of titanium in its metallic or other form.

A limited number of countries have restrictions concerning trade of titanium ores and concentrates. According to the OECD's inventory on export restrictions, India, Sierra Leone, and China use export taxes on titanium ores, concentrates and articles thereof ranging between 0% and 25%, while Vietnam uses export taxes ranging between 25% and 75% respectively. In Brazil, Madagascar, and Malaysia a license requirement is in place.

The broader range of titanium products, titanium scrap and unwrought titanium is subject to export restrictions, by countries such as Argentina, Burundi, India, Jamaica, Morocco, Kenya, Mozambique, Russia and the Ukraine (OECD 2019).

### 26.4.2 Supply from primary materials

#### 26.4.2.1 Geology, resources and reserves of titanium

**Geological occurrence:** The presence of titanium in the earth's crust is abundant, with TiO<sub>2</sub> being one of the 10 most common materials in the upper crust, resulting in crustal abundance

being expressed in mass fraction (wt %), namely 0.64% in case of TiO<sub>2</sub> (Rudnick and Gao, 2013).

The economically important sources for titanium metal and dioxide are ilmenite, titanite, anatase, leucosene, rutile, and synthetic rutile. Since the ionic radius of titanium is similar to some other common elements, titanium is present in most minerals, rocks, and soils. However, there are few titanium minerals with more than 1% titanium content. Another relevant source of titanium is titaniferous slag, which can contain up to 95% titanium dioxide (Enghag 2004).

Heavy-mineral exploration and mining projects were underway in Australia, Madagascar, Mozambique, Tanzania, and Sri Lanka (USGS, 2019). According to Minerals4EU (2019), some exploration is done for titanium in Spain, Sweden, Poland, Ukraine and Romania but with no further details.

**Global resources and reserves**<sup>274</sup>: Estimated world resources of ilmenite, rutile, and anatase might even add up to more than 2,000 million t (USGS, 2019). The identified world reserves are estimated to approximately 940,000 kt of titanium in ilmenite and rutile. Ilmenite accounts for about 89% of the world's consumption of titanium minerals. Australia, China, India and South Africa are hosts of the largest titanium reserves (USGS, 2019). According to the U.S. Geological Survey (2019), reserves for China were revised based on data from the National Bureau of Statistics of China.

**Table 204: Global reserves of titanium in 2018. Data from (USGS, 2019)**

Country	Estimated titanium reserves (kt of TiO <sub>2</sub> content)	Percentage of the total (%)
<b>Ilmenite</b>		
Australia	250,000	28.3
Brazil	43,000	4.9
Canada	31,000	3.5
China	230,000	26.1
India	85,000	9.6
Kenya	54,000	6.1
Madagascar	40,000	4.5
Mozambique	14,000	1.6
Norway	37,000	4.2
Senegal	N/A	N/A
South Africa	63,000	7.1
Ukraine	5,900	0.7
United States	2,000	0.3
Vietnam	1,600	0.2
Other Countries	26,000	2.9
World total (ilmenite, rounded)	880,000	100

<sup>274</sup> There is no single source of comprehensive evaluations for resources and reserves that apply the same criteria to deposits of titanium in different geographic areas of the EU or globally. The USGS collects information about the quantity and quality of mineral resources but does not directly measure reserves, and companies or governments do not directly report reserves to the USGS. Individual companies may publish regular mineral resource and reserve reports, but reporting is done using a variety of reporting systems depending on the location of their operation, their corporate identity and stock market requirements. Translations between national reporting codes are possible by application of the CRIRSCO template which is also consistent with the United Nations Framework Classification (UNFC) system. However, reserve and resource data are changing continuously as exploration and mining proceed and are thus influenced by market conditions and should be followed continuously.

Country	Estimated titanium reserves (kt of TiO <sub>2</sub> content)	Percentage of the total (%)
<b>Rutile</b>		
Australia	29,000	46.8
India	7,400	11.9
Kenya	13,000	21
Mozambique	880	1.4
Senegal	N/A	N/A
Sierra Leone	490	0.8
South Africa	8,300	13.4
Ukraine	2,500	4
United States	(included in ilmenite)	-
Other Countries	400	0.7
World total (rutile, rounded)	62,000	100
World total (ilmenite and rutile, rounded)	940,000	-

**EU resources and reserves**<sup>275</sup>: Resource data for some countries in Europe are also available (see Table 205) at Minerals4EU (2019) but cannot be summed as they are partial and they do not use the same reporting code (USGS, 2019). The resources of titanium are located in Finland and Sweden and amount to 1,800 kt of TiO<sub>2</sub> content. Historical resource estimates of titanium resources for Portugal and France are also available in the Minerals4EU website. Reserves are respectively illustrated in Table 206, amount approximately 200,000 kt of ore and are mainly located in Norway and Slovakia. Nevertheless, they do not use an established reporting code.

**Table 205: Resource data for the EU compiled in the European Minerals Yearbook of Minerals4EU (2019)**

Country	Classification	Quantity (million t of ore)	Grade (% Cr)	Reporting code	Reporting date	Source
Portugal	Historic resource estimate	690,000 m <sup>3</sup>	21.12%	None	11/2014	(Minerals4EU 2019)
France	Historic Resource Estimates	0.84	-	None	11/2014	(Minerals4EU 2019)
Finland	Indicated	39	4.9%	JORC	11/2014	(Minerals4EU 2019)

<sup>275</sup> For Europe, there is no complete and harmonised dataset that presents total EU resource and reserve estimates for titanium. The Minerals4EU project is the only EU-level repository of some mineral resource and reserve data for titanium, but this information does not provide a complete picture for Europe. It includes estimates based on a variety of reporting codes used by different countries, and different types of non-comparable datasets (e.g. historic estimates, inferred reserves figures only, etc.). In addition, translations of Minerals4EU data by application of the CRIRSCO template is not always possible, meaning that not all resource and reserve data for titanium at the national/regional level is consistent with the United Nations Framework Classification (UNFC) system (Minerals4EU 2019). Many documented resources in Europe are based on historic estimates and are of little current economic interest. Data for these may not always be presentable in accordance with the UNFC system. However a very solid estimation can be done by experts.

Country	Classification	Quantity (million t of ore)	Grade (% Cr)	Reporting code	Reporting date	Source
Sweden	Indicated	88.8	0.06%	JORC	11/2014	(Minerals4EU 2019)
Norway	Indicated Total	31.7 635	3.77% rutile 18% ilmenite	None	11/2014	(Minerals4EU 2019)
Slovakia	Verified (Z1)	0.068	16% economic	None	11/2014	(Minerals4EU 2019)
Albania	A	99	5 -6.4%	Nat. rep. code	11/2014	(Minerals4EU 2019)

**Table 206: Reserve data for the EU compiled in the European Minerals Yearbook of the Minerals4EU website (Minerals4EU 2019)**

Country	Classification	Quantity (million t of ore)	Grade (% Cr)	Reporting code	Reporting date	Source
Norway	Known reserves	200	18%	None	11/2014	(Minerals4EU 2019)
Slovakia	Verified (Z1)	0.068	16%	None	11/2014	(Minerals4EU 2019)

#### 26.4.2.2 Titanium mining

Titanium chiefly is obtained from the minerals rutile, ilmenite and rarely from anatase (beta-titanium dioxide). Other titanium-bearing minerals include perovskite, sphene and titanite. Titanium can be mined from intrusive crystalline rocks, weathered rock and unconsolidated sediments. Half of all Titanium mined comes from unconsolidated sediments known as shoreline placer deposits. Placers are alluvial deposits formed by rivers as they reach the sea. Suspended sediments have different densities known as specific gravities. A river will deposit different sediments as its speed fluctuates, forming separate layers of sediment. Titanium's ores, ilmenite and rutile are both found in placers worldwide. Placer deposit mining is either done as a wet dredge or dry mining operation. The presence and height of the water table where the deposit is found dictates which method is the most suitable to be applied.

In wet dredge mining, an artificial pond is created by digging below the water table. In some cases mining ponds are filled using water pumps. A suction bucket wheel attached to a floating dredge is used to remove heavy mineral sediment from the ground, which is then concentrated by passing it through a set of inclined cylindrical trommel screens. While these are rotating the material that is too small for processing falls through the screens. The particles that make it this far are then sorted by a spiral concentrator where a chute sorts particles suspended in water based on their size and density. The high-density particles stay closest to the inside of the spiral chutes cross-section with the lower density particles on the outside edge. Hence, the sorted sediments are collected in separate containers.

On the other hand, dry mining of ilmenite and rutile is carried out with conventional mechanical excavation including excavators, scrapers, loaders and bulldozers. Like wet dredging, the

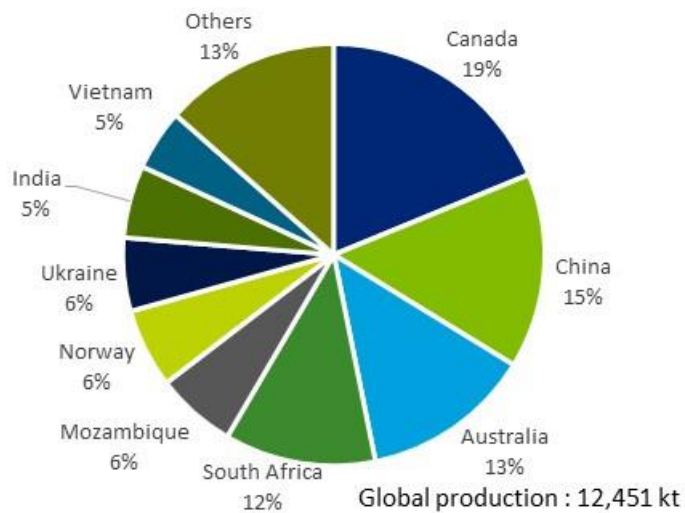
sediments from dry mining also need to be concentrated, following the aforementioned process but without water in the spiral concentrator.

After the minerals have been concentrated they are put through the feed preparation plant where they are cleaned with attrition scrubbers and subjected to additional gravity concentration before undergoing froth flotation which can remove sulphides or other local unwanted sediment.

The last step is the dry mill, where a combination of magnetic and electrostatic separation is used to improve the quality of the ore. Titanium’s ores ilmenite and rutile are conductive because of their iron content and can be easily separated from zircon and unwanted silicates. After the dry mill, the ore is ready for further processing.

### 26.4.2.3 World and EU mine production

The world mine production of titanium was 12,451 kt per year as an average over a period from 2012 to 2016 (BGS, 2019). Canada is the world’s largest titanium ore producer, contributing about 19% of the total world supply. Other important suppliers of titanium ores and concentrates are China (20%), Australia (17%), South Africa (15%) and Mozambique (8%). There is significant production of approximately 756 kt per year taking place in Norway and of 700 kt in Ukraine respectively (BGS, 2019).



**Figure 485: Global mine production of titanium, average 2012–2016 (BGS, 2019).**

## 26.4.3 Processing of titanium ore

### 26.4.3.1 Production of titanium dioxide and metal

Titanium was first isolated as a pure metal in 1910, but it wasn’t until 1948 that metal was produced commercially using the Kroll process (named after its developer, William Kroll) to reduce titanium tetrachloride with magnesium to produce titanium metal (Zheng and Okabe, 2010; Bordbar, Yousefi and Abedini, 2017). The steps involved include extraction, purification, sponge production, alloy creation, and forming and shaping. The production of titanium metal accounts for only 5% of annual titanium mineral consumption.

In Europe and the United States (European and North American markets respectively), many manufacturers specialize in different phases of this production. For example, there are

manufacturers that just make the sponge, others that only melt and create the alloy, and still others that produce the final products (ITA 2019).

Titanium dioxide is produced from raw materials mainly through the sulphate process or the more environmentally acceptable carbo-chlorination process that converts  $\text{TiO}_2$  into  $\text{TiCl}_4$  (Zheng and Okabe, 2010; Bordbar, Yousefi and Abedini, 2017). The choice for a process at this stage depends on for instance the titanium material content of the ore, the desired resulting pigments and the allowable amount of waste (ECI, 2016). The latter process also supplies the  $\text{TiCl}_4$  necessary for the production of titanium metal.

Environmental and economic constraints dictate that the ore feed stocks converted by carbo-chlorination processes now in use contain greater than 90% titanium dioxide. Nevertheless, only natural rutile meets this requirement, while ilmenite can be upgraded through combinations of pyrometallurgical and hydrometallurgical techniques to produce a synthetic rutile of 90% to 93%  $\text{TiO}_2$ . In addition, titaniferous magnetite ores can be smelted to produce pig iron and titanium-rich slags. Rutile, leucoxene, synthetic rutile, and slag can then be mixed to provide a feed stock of more than 90%  $\text{TiO}_2$  for the chlorination process (Zhang 2011).

The extracted materials undergo several chemical reactions resulting in the creation of impure titanium tetrachloride ( $\text{TiCl}_4$ ) and carbon monoxide. Impurities are a result of the fact that pure titanium dioxide is not used at the start. Therefore the various unwanted metal chlorides that are produced must be removed (Zheng and Okabe, 2010; Roskill, 2019).

The reacted metal is purified by distillation and precipitation and treated with magnesium. The titanium solid is removed from the reactor by boring and then it is treated with water and hydrochloric acid to remove excess magnesium and magnesium chloride. The resulting solid is a porous metal called a sponge. The pure titanium sponge can then be converted into a usable alloy via a consumable-electrode arc furnace. At this point, the sponge is mixed with the various alloy additions and scrap metal. The exact proportion of sponge to alloy material is formulated in a lab prior to production. This mass is then pressed into compacts and welded together, forming a sponge electrode (Bhushan Ishwar 2016).

#### **26.4.3.2 World and EU titanium dioxide and metal production**

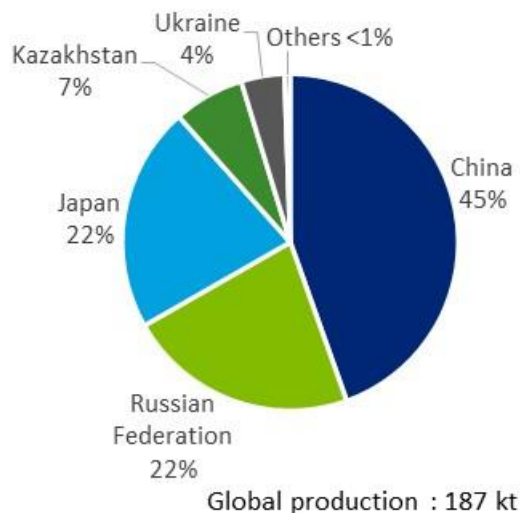
The world production of titanium dioxide can be compared to the overall supply of ores and concentrates, as these have been discussed in the previous sessions of this factsheet. However, when it comes to the production of titanium metal (sponge), the numbers are slightly different.

The global annual production of titanium metal on average over a period from 2012-2016 was 187,240 t. China accounts for 83 kt (45%) of the global annual production. Russia and Japan also hold a 22% of the production each, while Kazakhstan, Ukraine and India consist of the remaining significant titanium sponge producers (USGS, 2019).

Titanium dioxide pigments are made from two chemical processes: the sulphate or the chloride process. The chloride process produces titanium dioxide products by reacting titanium ores with chlorine gas. The sulphate process produces titanium dioxide products by reacting titanium ores with sulphuric acid. 70% of the European production is from the sulphate process and 30% from the chloride process<sup>276</sup>.

---

<sup>276</sup> <https://ec.europa.eu/environment/waste/titanium.html>



**Figure 486: Global production of titanium metal (sponge). Average 2012-2016. Data from (USGS, 2019)**

#### **26.4.4 Supply from secondary materials/recycling**

In 2012, about 35,000 t of new scrap and 1,000 t of old scrap were recycled. Whereas the steel industry used about 10,000 t of recycled titanium and ferrotitanium, 1,000 t were used by the super-alloy industry and further 1,000 t by other industries. Today, recycled content from old scrap accounts for 6% of the entire use. In the future, recycled titanium will only cover a small share of the demand, due to a fast rising consumption (UNEP, 2011).

Processing and consequently using titanium scrap is a longstanding practice with patents dating back to the 1950s. The cold hearth melting process contributed to a greater input of secondary titanium starting from the 1980s. (Newman, 2015)

The end of life recycling input rate for titanium is estimated to be 19%, using the UNEP methodology (UNEP, 2011) (SCRREEN workshops 2019). For the primary material input we take the amount found in this study from (BGS, 2019) of 12,345 kt. The (UNEP, 2011) report offers amounts of scrap of titanium that are used worldwide. A recycled end-of-life material input (old scrap) of 2,716 kt, an amount of scrap used in fabrication (new and old scrap) 1,630 kt and scrap used in production (new and old scrap) of 244 kt.

### **26.5 Other considerations**

---

#### **26.5.1 Environmental issues**

Titanium has low toxicity and thus no environmental effects have been reported. It should be noted though that when in metallic powdered form, titanium metal poses a significant fire hazard and, when heated in air, an explosion hazard (ITA 2015).

The waste arising from the titanium dioxide production cover solid waste, strong acid waste, weak acid waste, neutralised waste, treatment waste and dust. Existing Community legislation on waste from the titanium dioxide industry aims to prevent and progressively reduce pollution caused by waste from the titanium dioxide industry with a view to the elimination of such

pollution. It also seeks to harmonise laws on waste from the titanium dioxide industry in order to avoid distortion of competition within the internal market.

Since the Titanium Dioxide Directives are more than 15 years old (reference year 2019), they could, in line with the Commission's Action plan "Simplifying and improving the regulatory environment"<sup>277</sup>, be candidates for simplification<sup>278</sup>.

### **26.5.2 Contribution to low-carbon and green technologies**

Due to their high tensile strength to density ratio, high corrosion resistance, and ability to withstand moderately high temperatures without creeping, titanium alloys are used in gas turbines. The Greater Operating Temperature Alloy (GOTA) (2016) developed a titanium alloy which can sustain higher operating temperatures in the compressor of gas turbines to lower fuel consumption and, thus, pollutant emissions of aero engines. While aluminium-based alloys offer excellent strength-to-weight ratio, their use is limited to temperatures below 130 °C, restricting potential application within gas turbines. Stainless steels offer similar strength to most titanium alloys, but with a significant density penalty of over 50 %<sup>279</sup>.

### **26.5.3 Health and safety issues**

Human exposure to TiO<sub>2</sub> nanoparticles may occur during both manufacturing and use. The major routes of TiO<sub>2</sub> nanoparticle exposure that have toxicological relevance in the workplace are inhalation and dermal exposure. TiO<sub>2</sub> is routinely handled by millions of workers without the potential for inhalation exposure. It is reported that more than 150 items of "manufacturer-identified nanotechnology-based consumer products would have long term dermal contact (Shi, H. et al., 2013). There is a detectable amount of titanium in the human body and it has been estimated that we take in about 0.8 mg/day, but most passes through us without being adsorbed.

Nevertheless, there are effects of overexposure to titanium powder: Dust inhalation may cause tightness and pain in chest, coughing, and difficulty in breathing. Contact with skin or eyes may cause irritation. Routes of entry: Inhalation, skin contact, eye contact.

Carcinogenicity: The International Agency for Research on Cancer (IARC) has listed titanium dioxide within Group 3 (The agent is not classifiable as to its carcinogenicity to humans).

A formal (legal) classification of TiO<sub>2</sub> as Carc. 2 (by inhalation) has been adopted by the Commission and is currently undergoing scrutiny by EP and Council. In case EP and Council do not object, the classification will enter into force in Spring 2020. Entry into application takes place 18 months after entry into force.

EU OSH requirements exist to protect workers' health and safety, employers need to identify which hazardous substances they use at the workplace, carry out a risk assessment and introduce appropriate, proportionate and effective risk management measures to eliminate or control exposure, to consult with the workers who should receive training and, as appropriate, health surveillance<sup>280</sup>.

---

<sup>277</sup> Communication from the Commission of 5.6.2002, COM (2002)278 final, which is part of the Better Lawmaking Packaging, see /governance/suivi\_lb\_en.htm.

<sup>278</sup> <https://ec.europa.eu/environment/waste/titanium.htm> (last updated: 07/08/2019)

<sup>279</sup> <https://cordis.europa.eu/article/id/148991-titanium-in-the-gas-turbine-engine>

<sup>280</sup> <https://ec.europa.eu/social/main.jsp?catId=148>



## 26.5.4 Socio-economic issues

Due to the applications and safety profile of titanium dioxide, it plays an important role in efforts to reuse, sustain and recycle materials. With its unique characteristics it also provides longer-lasting products, resulting in less waste.

## 26.6 Comparison with previous EU assessments

---

The assessment of titanium has resulted in shifts in criticality scores both for economic importance and supply risk because the critical stage is the metal stage, not assessed in the previous assessment (titanium sponge, essential in high-tech applications).

**Table 207: Economic importance and supply risk results for titanium in the assessments of 2011, 2014, 2017, 2020 (European Commission, 2011)(European Commission, 2014)(European Commission, 2017)**

Assessment	2011		2014		2017		2020	
	EI	SR	EI	SR	EI	SR	EI	SR
Titanium	5.38	0.13	5.54	0.13	4.3	0.3	4.66	1.26

In the 2020 assessment, the value-added data used in the calculation of economic importance correspond to 5-year average 2012-2016 values. The supply risk has been analysed at both mine and processing stages of the value chain. In the case of metal stage, the Supply Risk (SR) was calculated using the HHI for global supply only because of the lack of trade data.

## 26.7 Data sources

---

The CN code 2614 00 00, labelled "Titanium ores and concentrates" is used for the trade analysis. For Titanium metal sponge there are no trade codes available from Eurostat Comext (2019).

### 26.7.1 Data sources used in the factsheet

BGS (2019) World mineral statistics data, British Geological Survey. Available at: <https://www.bgs.ac.uk/mineralsuk/statistics/wms.cfc?method=searchWMS> (Accessed: 30 July 2019).

Bordbar, H., Yousefi, A. A. and Abedini, H. (2017) 'Production of titanium tetrachloride (TiCl<sub>4</sub>) from titanium ores: A review', *Polyolefins Journal*, 4(2), pp. 149–173. doi: 10.22063/poj.2017.1453.

BRGM (2017) Le titane (Ti)-éléments de criticité 2-PRODUCTION MONDIALE ET RESSOURCES. Available at: [www.eramet.com](http://www.eramet.com) (Accessed: 26 November 2019).

Bhushan Ishwar, M. (2016) International Journal of Current Engineering and Technology Extra Ordinary Properties of Titanium Useful in Various Sectors and Enlightenment of 'The Kroll Process'. Available at: <http://inpressco.com/category/ijcet> (Accessed: 28 January 2020).

Cooper, S. P. and Whitley, G. H. (1987) 'Titanium in the power generation industry', *Materials Science and Technology*. Taylor & Francis, 3(2), pp. 91–96. doi: 10.1179/mst.1987.3.2.91.

DERA (2013) Rohstoffinformationen. Ursachen von Preispeaks, -einbrüchen und -trends bei mineralischen Rohstoffen. Available at: [http://www.deutsche-rohstoffagentur.de/DE/Gemeinsames/Produkte/Downloads/DERA\\_Rohstoffinformationen/rohstoffinformationen-17.pdf?\\_\\_blob=publicationFile&v=2](http://www.deutsche-rohstoffagentur.de/DE/Gemeinsames/Produkte/Downloads/DERA_Rohstoffinformationen/rohstoffinformationen-17.pdf?__blob=publicationFile&v=2).

DERA (2019) Pricelist of raw materials/. Available at: [https://www.bgr.bund.de/DE/Themen/Min\\_rohstoffe/Produkte/produkte\\_node.html?tab=Rohstoffpreise](https://www.bgr.bund.de/DE/Themen/Min_rohstoffe/Produkte/produkte_node.html?tab=Rohstoffpreise) (Accessed: 7 July 2019).

ECI (2016) Titanium dioxide. Available at: <http://www.essentialchemicalindustry.org/chemicals/titanium-dioxide.html> (Accessed: 8 July 2019).

Enghag, P. (2004) 'Titanium, in *Encyclopedia of the Elements: Technical Data - History - Processing - Applications*. With a Foreword by Bengt Nordén', Wiley-VCH Verlag GmbH & Co. KGaA, Weinheim, Germany. doi: 10.1002/9783527612338.ch18.

European Commission (2011) Critical raw materials.

European Commission (2014) Report on critical raw materials for the EU - Critical raw materials profiles.

European Commission (2017) Study on the review of the list of critical raw materials. Critical Raw Material Factsheets. European Commission. doi: 10.2873/398823.

Eurostat (2019a) Easy Comext database. Available at: <http://epp.eurostat.ec.europa.eu/newxtweb/>.

Eurostat (2019b) Statistics on the production of manufactured goods (PRODCOM NACE Rev.2), Prodcom - Statistics by Product. Available at: <https://ec.europa.eu/eurostat/web/prodcom> (Accessed: 14 July 2019).

Haider, A. J. et al. (2017) 'Exploring potential Environmental applications of TiO<sub>2</sub> Nanoparticles', *Energy Procedia*. Elsevier B.V., 119, pp. 332–345. doi: 10.1016/j.egypro.2017.07.117.

ITA (2015) International Titanium Association. Kevin L. Kreitman EFO-Fire Chief, Redding CA International Titanium Association Hazards of Combustible Metals-Titanium.

ITA (2019) International Titanium Association, website. Available at: <https://titanium.org/> (Accessed: 24 November 2019).

Kim, K.T., Eo, M.Y., Nguyen, T.T.H. and Kim, S. M. (2019) 'General review of titanium toxicity, *Inter. Journal of Implant Dentistry*, (2019)5:10'. Available at: <https://doi.org/10.1186/s40729-019-0162-x>.

Marscheider-Weidemann, F., Langkau, S., Hummen, T., Erdmann, L., Tercero Espinoza, L., Angerer, G., Marwede, M. and Benecke, S. (2016) Rohstoffe für Zukunftstechnologien 2016. DERA Rohstoffinformationen.

Minerals4EU (2019) European Minerals Yearbook. Available at: [http://minerals4eu.brgm-rec.fr/m4eu-yearbook/theme\\_selection.html](http://minerals4eu.brgm-rec.fr/m4eu-yearbook/theme_selection.html) (Accessed: 9 July 2019).

Narayan and Raju (1999) 'Use of calcined clay as part replacement of titanium dioxide in latex paint formulations. *Journal of Applied Polymer Science* 77(5):1029 – 1036.'

- Newman, E. (2015) 'Recycling trends. Titanium Europe from the International Titanium Organization'. Available at: <http://c.ymcdn.com/sites/www.titanium.org/resource/resmgr/NewmanEdTiEU2015Recycling.pdf>.
- OECD (2019) 'OECD Export restrictions on Industrial Raw Materials database'. Available at: [https://qdd.oecd.org/subject.aspx?Subject=ExportRestrictions\\_IndustrialRawMaterials](https://qdd.oecd.org/subject.aspx?Subject=ExportRestrictions_IndustrialRawMaterials).
- PCI (2015) Paint and Coatings Industry. A Review of Global Supply and Demand for Titanium Dioxide | 2015-01-06 | PCI Magazine. Available at: <https://www.pcimag.com/articles/100036-a-review-of-global-supply-and-demand-for-titanium-dioxide> (Accessed: 28 January 2020).
- Reade (2019) Reade International Corp., Titanium Metal (Ti) / Sponge / Titanium Powder. Available at: <https://www.reade.com/products/titanium-metal-ti-sponge-titanium-powder> (Accessed: 28 November 2019).
- Roskill (2019) Titanium Metal: Outlook to 2029, 9th edition. Available at: 12 June 2019.
- Rudnick, R. L. and Gao, S. (2013) Composition of the Continental Crust. 2nd edn, Treatise on Geochemistry: Second Edition. 2nd edn. Elsevier Ltd. doi: 10.1016/B978-0-08-095975-7.00301-6.
- Shi, H., Magaye, R., Castranova, V. and Zhao, J. (2013) 'Titanium dioxide nanoparticles: a review of current toxicological data, Particle and Fibre Toxicology 2013, 10:15'. Available at: <http://www.particleandfibretoxicology.com/content/10/1/15>.
- Tercero Espinoza, L., Hummen, T., Brunot, A., Hovestad, A., Pena Garay, I., Velte, D., Smuk, L., Todorovic, J., van der Eijk, C. and Joce, C. (2013) 'Critical Raw Materials Substitution Profiles. September 2013 Revised May 2015. CRM\_InnoNet Available at': Available at: <http://www.criticalrawmaterials.eu/wp-content/uploads/D3.3-Raw-Materials-Profiles-final-submitted-document.pdf>.
- TMR (2016) Transparency Market Research - Titanium Market - Global Industry Analysis, Size, Share, Growth, Trends and Forecast 2017 - 2025. Available at: Available at: <https://www.transparencymarketresearch.com/titanium-market.html> (Accessed: 3 June 2019).
- TNO (2015) 'TNO innovation for Life, Annual Report, 2015'. Available at: [https://www.tno.nl/media/7838/tno\\_annual\\_report\\_2015\\_web.pdf](https://www.tno.nl/media/7838/tno_annual_report_2015_web.pdf).
- Uhlmann E. (2001) Cutting and Drilling of Metals and Other Materials: a comparison. E. Uhlmann, T. Frost, in Encyclopedia of Materials: Science and Technology, 2001
- UNEP (2011) Recycling rates of Metals - A status Report, A Report of the Working Group on the Global Metal Flows to the International Resource Panel.
- USGS (2016) 'Titanium Minerals Yearbook'. Available at: <https://minerals.usgs.gov/minerals/pubs/commodity/titanium/myb1-2014-titan.pdf>.
- USGS (2019) Mineral Commodity Summaries 2019. U.S Geological Survey. doi: 10.1007/978-3-540-47108-0-4.
- Zafar, S. (2019) 'Titanium - An Environmental Vanguard Among Metals, BioEnergy Consult'. Available at: <https://www.bioenergyconsult.com/titanium-an-environmental-vanguard>.
- Zheng and Okabe (2010) 'Selective chlorination of titanium ore and production of titanium powder by perform reduction process (PRP), 1-6'. Available at: <http://citeseerx.ist.psu.edu/viewdoc/download?doi=10.1.1.624.8700&rep=rep1&type=pdf>.

Zhang (2011) A literature review of titanium metallurgical processes. Zhang W., Zhu, Z., Cheng, C. Y.. July 2011. Hydrometallurgy 108(3):177-188 doi:10.1016/j.hydromet.2011.04.005

### **26.7.2 Data sources used in the criticality assessment**

BGS (2019). BGS- World Mineral Statistics database; World Mineral Production 2012-2016 reports

Estebaranz M. and de Kort, P. (2016). *Analysis of alternatives for titanium dioxide as colourant additive in plastic industry*, Polymer Comply Europe. Available at: [https://www.pvch.ch/wp-content/uploads/2016/10/2016-09-23\\_PCE-Analysis-of-Alternatives-of-Titanium-dioxide-as-colourant-additive-in-plastic-industry-v0.3.pdf](https://www.pvch.ch/wp-content/uploads/2016/10/2016-09-23_PCE-Analysis-of-Alternatives-of-Titanium-dioxide-as-colourant-additive-in-plastic-industry-v0.3.pdf). (Accessed: 8 July 2019).

European Commission (2011) *Critical raw materials*. Available at: [https://ec.europa.eu/growth/sectors/raw-materials/specific-interest/critical\\_en](https://ec.europa.eu/growth/sectors/raw-materials/specific-interest/critical_en) (Accessed: 8 July 2019).

European Commission (2014) *Report on critical raw materials for the EU - Critical raw materials profiles*. Available at: <https://ec.europa.eu/docsroom/documents/11911/attachments/1/translations/en/renditions/pdf>.

European Commission (2017a) *Study on the review of the list of critical raw materials. Critical Raw Material Factsheets*. European Commission. doi: 10.2873/398823.

European Commission (2017b) *Study on the review of the list of critical raw materials. Non-critical raw materials factsheets*. European Commission. doi: 10.2873/876644.

European Commission (2019). DG Trade website "Agreements", Available at: <http://ec.europa.eu/trade/policy/countries-and-regions/agreements/>

Eurostat (2019a) *Annual detailed enterprise statistics for industry (NACE Rev. 2, B-E)*. Available at: [https://ec.europa.eu/eurostat/en/web/products-datasets/-/SBS\\_NA\\_IND\\_R2](https://ec.europa.eu/eurostat/en/web/products-datasets/-/SBS_NA_IND_R2) (Accessed: 7 July 2019).

Eurostat (2019b) *Easy Comext database*. Available at: <http://epp.eurostat.ec.europa.eu/newxtweb/> (Accessed: 7 July 2019).

Haider, A. J., AL- Anbari, R. H., Kadhim, G. R. and Salame, C. T. (2017). *Exploring potential Environmental applications of TiO<sub>2</sub> Nanoparticles*, Energy Procedia, 119(2017): 332-345. <https://doi.org/10.1016/j.egypro.2017.07.117>

Henriques, V.A.R. (2009). *Titanium production for aerospace applications*, Journal of Aerospace Technology and Management, 1(1): 7-17. <http://dx.doi.org/10.5028/jatm.2009.01010717>.

Inagaki, I., Takechi, T., Shirai, Y. and Ariyasu, N. (2014). *Application and features of titanium for the aerospace industry*, Nippon Steel & Sumitomo Metal Technical Report No 106. Available at: <https://www.nipponsteel.com/en/tech/report/nssmc/pdf/106-05.pdf>. (Accessed: 5 July 2019).

ITF (2019). International Titanium Foundation (ITF). Available at: <http://titaniumfoundation.org/>. (Accessed: 5 July 2019).

OECD (2019a) *Export restrictions on Industrial Raw Materials*. Available at: [https://qdd.oecd.org/subject.aspx?Subject=ExportRestrictions\\_IndustrialRawMaterials](https://qdd.oecd.org/subject.aspx?Subject=ExportRestrictions_IndustrialRawMaterials) (Accessed: 5 July 2019).

OECD (2019b) *Due Diligence Guidance for Responsible Supply Chains of Minerals from Conflict-*

*Affected and High-Risk Areas*. Available at: [https://www.oecd-ilibrary.org/governance/oecd-due-diligence-guidance-for-responsible-supply-chains-of-minerals-from-conflict-affected-and-high-risk-areas\\_9789264185050-en](https://www.oecd-ilibrary.org/governance/oecd-due-diligence-guidance-for-responsible-supply-chains-of-minerals-from-conflict-affected-and-high-risk-areas_9789264185050-en) (Accessed: 5 July 2019).

Ti-Pure (2017). *Titanium dioxide for coatings*. Available at: [https://www.chemours.com/Titanium\\_Technologies/en\\_US/assets/downloads/Ti-Pure-for-coatings-overview.pdf](https://www.chemours.com/Titanium_Technologies/en_US/assets/downloads/Ti-Pure-for-coatings-overview.pdf). (Accessed: 01 May 2019)

TNO (2015). *TNO innovation for Life, Annual Report, 2015*. Available at: [https://www.tno.nl/media/7838/tno\\_annual\\_report\\_2015\\_web.pdf](https://www.tno.nl/media/7838/tno_annual_report_2015_web.pdf). (Accessed: 01 July 2019).

UNEP (2011). *Recycling rates of metals: A status report*, United Nations Environment Programme, Available at: [http://wedocs.unep.org/bitstream/handle/20.500.11822/8702/-/Recycling%20rates%20of%20metals%3a%20A%20status%20report-2011Recycling\\_Rates.pdf?sequence=3&isAllowed=y](http://wedocs.unep.org/bitstream/handle/20.500.11822/8702/-/Recycling%20rates%20of%20metals%3a%20A%20status%20report-2011Recycling_Rates.pdf?sequence=3&isAllowed=y) (Accessed: 16 September 2019)

USGS (2019). *Mineral Commodity Summaries - Titanium reports (2012; 2013; 2014; 2015;2016)*

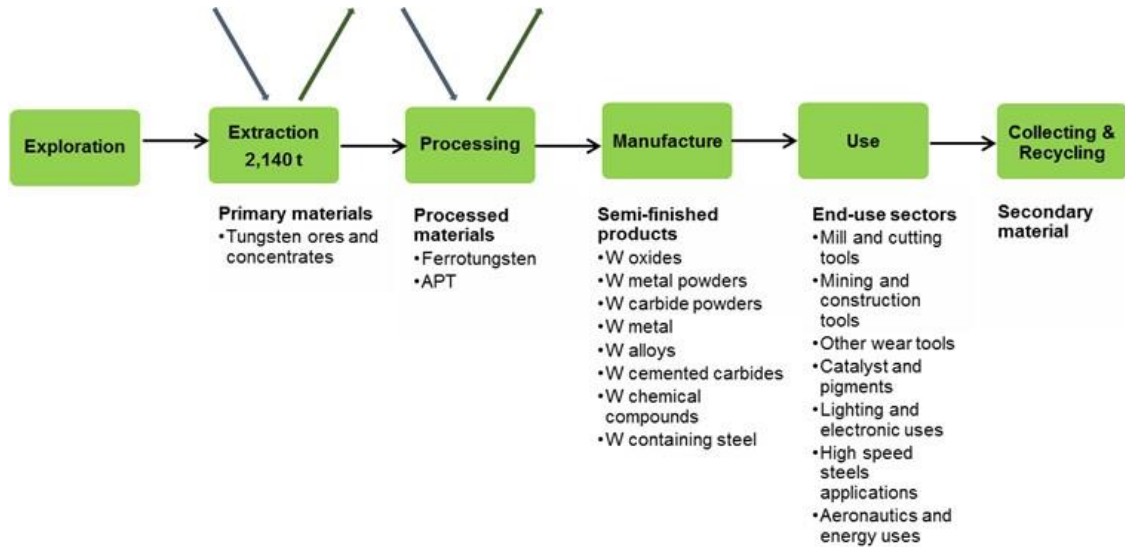
## **26.8 Acknowledgments**

---

This factsheet was prepared by the JRC in collaboration with Mr. Georgios Barakos (TU Bergakademie, Freiberg, Germany). The authors would like to thank the Ad Hoc Working Group on Critical Raw Materials as well as experts participating in SCRREEN workshops for their contribution and feedback.

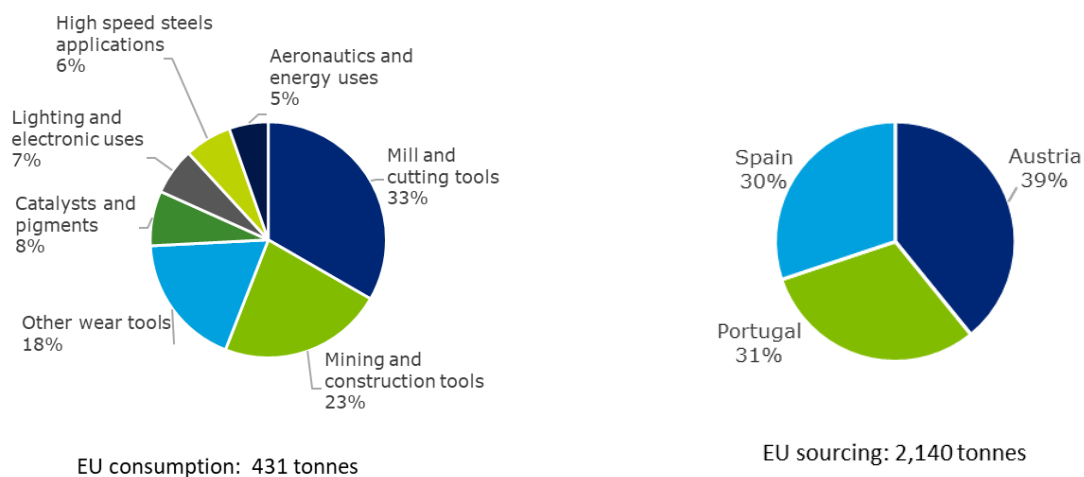
# 27 TUNGSTEN

## 27.1 Overview



**Figure 487: Simplified value chain for tungsten for the EU, average 2012-2016<sup>281</sup>**

Tungsten (chemical symbol W), also known as wolfram, is a hard, rare metal. Tungsten is found naturally on Earth almost exclusively in chemical compounds. Its important ores include wolframite and scheelite. The free element is remarkable for its robustness and has the highest melting point of all the elements. Its high density is 19.3 g/cm<sup>3</sup>, comparable to uranium and gold. Tungsten was on the EU's list of CRMs in 2011, 2014 and 2017.



<sup>281</sup> JRC elaboration on multiple sources (see next sections). Import figure (represented by black arrow) and export figure (represented by green arrow) at mine stage and processing stage are not reported due to the lack of data reliability (see EU trade section).

**Figure 488: End uses of tungsten (SCRREEN, 2019) and EU sourcing of ores and concentrates<sup>282</sup>, 2012-2016 (WMD, 2019)**

For the purpose of this assessment tungsten is analysed at both extraction and processing stage. At mine stage, tungsten is assessed as tungsten ores and concentrates (Trade code CN8 26110000). At processing stage, the assessment focused on ferrotungsten (CN code 72028000 Ferro-tungsten and ferro-silico-tungsten, containing 22% of W), Amonium Paratungstate (APT) (CN code 284180 Tungstates 'wolframates', containing 70.2% of W), tungsten carbides (28499030 Carbides of tungsten, whether or not chemically defined), and tungsten powders (81011000) (Eurostat Comext, 2019).

The majority of tungsten is traded on annual contracts and only small amounts are sold on the open market (BGS, 2011; SCRREEN workshops, 2019). The prices of tungsten concentrates at the US spot market have reached their lowest in 2016 since 2012, from USD 358 per tonne of WO<sub>3</sub> in 2012 to USD 148 per tonne of WO<sub>3</sub> in 2016 as reported by the USGS. The same trend was observed also for the prices of APT and ferrotungsten. After 2016, the prices of tungsten concentrates, APT, and ferrotungsten showed an increasing trend. Experts argue that the state-influenced decision in China, as the largest producer of tungsten products, may influence the price mechanism and as a consequence, affecting the viability of tungsten mine and processing sector in the EU (Eurometaux, 2020).

Over the years 2012 to 2016, the average EU apparent consumption of tungsten ores and concentrates was estimated at 431 tonnes per year. The EU production of tungsten ores and concentrates, accounting for a total of 2,140 tonnes took place in Austria (39%), Portugal (31%), and Spain (30%). The figure on the EU import and export of tungsten ores and concentrates suggested that the EU was a net exporter of tungsten ores and concentrates during 2012-2016. At processing stage, the EU was a net importer of several tungsten products. However, the reliability of Eurostat-Comext data was challenged by experts both for tungsten ores and concentrates and tungsten-based products, since several companies have withheld from giving information for confidentiality issue (Eurometaux, 2019). Therefore, the import and export figures of tungsten ores and concentrates and tungsten-based products presented in this factsheet may not represent the full picture for the EU. As a result, in this criticality assessment, a reliable EU supply risk value for tungsten in ores and concentrates form could not be calculated.

Tungsten is an important metal with no substitutes, and a key component in steel manufacturing, construction, oil drilling, and mining industries. It is also used in the fabrication of wires and filaments used in electrical, heating, and lighting applications. The hardness and high density of this metal give it military applications in penetrating projectiles. Tungsten compounds are also often used as industrial catalysts. Tungsten has very special performance and is most of the time the best choice of material, so very low substitution exists for this material in the industrial reality.

World tungsten known resources have been estimated at 7 million tonnes of contained W metal (USGS, 2019a). World tungsten resources are geographically widespread. The largest tungsten resources and reserves are known to be in China. Other countries like Canada, Kazakhstan, Russia, and the United States also have significant tungsten resources (USGS, 2019a).

According to the USGS (2019a), world known reserves of tungsten stand at 3.3 million tonnes of contained tungsten metal, with more than 57% of these located in China. In Europe, according to Minerals4EU (2019), tungsten reserves are known to exist in Spain, the UK, Portugal, Poland,

---

<sup>282</sup> The EU import of tungsten ores and concentrates was not included in the estimation of EU sourcing due to the lack of completeness of the information reported in Eurostat-Comext.

Slovakia, and Czechia. However, the number cannot be summed as they are partial and they do not use the same reporting code.

During the years 2012-2016, the world annual production of tungsten ores and concentrates was estimated at 85,000 tonnes with 82% of production in China. (WMD, 2019). The European production of tungsten ores and concentrates took place in Austria, Portugal, and Spain, accounting for 3% of global tungsten ores and concentrates production (WMD, 2019). At processing stage, however, there is no official public source of information on the global production of processed tungsten.

Tungsten scrap continued to be an important source of raw material for the tungsten industry worldwide (USGS, 2019). Based on the material flow analysis performed in the MSA study, a 42% End-of-Life Recycling Input Rate (EOL-RIR) has been estimated (Bio Intelligence Service, 2015). A recent estimate reported 30% of EOL-RIR value (ITIA, 2018b).

China, the biggest tungsten producer worldwide, imposed an export quota 100,000 tonnes of tungsten concentrates in 2018. The quotas was split into 76,150 tonnes from primary tungsten mines and 23,850 tonnes of tungsten concentrate produced as a by-product from mining of other metals (ITIA, 2019). China also applied an export tax for its export of tungsten ores, together with Bolivia, Russia, Rwanda, and Vietnam. China applied export tax on ferrotungsten, APT, carbides of tungsten, and tungsten powders. On tungsten powders, Vietnam applied 5% export tax, that ended in 2017 (OECD, 2019).

With regards to safety issue, chronic inhalation or severe exposure to airborne tungsten dust particles and ingestion of large amounts of soluble tungsten compounds is known to be hazardous to human health (BGS, 2011; SCREEN workshops, 2019).

Tungsten is one of the four minerals falling under the scope of by an EU regulatory initiative (European Parliament, 2016).

## **27.2 Market analysis, trade and prices**

---

### **27.2.1 Global market analysis and outlook**

The global demand for tungsten in 2018 was estimated to be 104,500 tonnes of tungsten content. The demand for tungsten has increased from the demand in 2012 at 76,150 tonnes of W content (ITIA, 2019).

China is the biggest producer, exporter, and consumer of tungsten concentrates. Since more than 10 years, China does not allow export of tungsten concentrates (Eurometaux, 2019). Tungsten has been defined in the "National Mineral Resources Planning" (2016-2020) as a strategic mineral resource. Therefore, China planned to control tungsten exploitation at 120,000 tonnes of tungsten concentrates, equal to 62,000 tonnes of tungsten content by 2020. China has also imposed an environmental protection tax on pollution release generated by tungsten exploitation activities. To guarantee its domestic supply and demand of tungsten, China imposed an export quota 100,000 tonnes of tungsten concentrates in 2018, split into 76,150 tonnes from primary tungsten mines and 23,850 tonnes of tungsten concentrate produced as a by-product from mining of other metals (ITIA, 2019).

In 2012-2016, the big producers of tungsten concentrates outside China are Bolivia, Canada, Russia, Rwanda and Vietnam. The production of tungsten ores and concentrates from Canada ended in 2015 (World Mining data, 2019; Eurometaux, 2019). Bolivia, Russia, Rwanda, and Vietnam imposed a tax on its export of tungsten ores.



China is also a major exporter of tungsten intermediates such as tungsten oxides, tungstates (APT), tungsten powder, tungsten carbide, and ferrotungsten. China’s export of these intermediates was estimated at 25,969 tonnes in 2018, much higher than in 2014 at 17,270 tonnes (of W content, tungsten carbides excluded) (ITIA, 2019). These figures suggested that China increased the export of downstream products.

China applied an export tax on ferrotungsten, APT, carbides of tungsten, and tungsten powders. Vietnam applied an export tax on tungsten powders (OECD, 2019).

Tungsten materials, such as APT were traded on two Chinese exchanges—the Tianjin International Mining Exchange and the Fanya Metal Exchange (FYME) until the latter collapsed in 2015. Although the Fanya Metal Exchange ceased operations in 2015 following an investment scandal, the exchange reportedly held 29,651 tonnes of gross weight, of APT (containing nearly 20,900 tonnes of tungsten) by 2016 (USGS, 2016).

Experts (Eurometaux, 2020) argue that the economic viability of western mines depends on opaque pricing mechanisms dominated by state-influenced decisions in China (e.g., “environmental inspections” to reduce inflow or release of stockpiles) and severe over-capacity of APT production in Asia (notably China). The refinery-level industry in the EU faces the risk to be cut off from concentrate supplies, if APT prices are (possibly artificially) depressed.

There is no solid qualitative forecast of supply and demand of tungsten. Some experts view the overall supply risk of the EU midstream tungsten industry rather increased than reduced compared to 2017. Experts also believe that as a consequence, the downstream tungsten consuming industry in the EU would face an increased reliance on Asian (largely Chinese) tungsten supplies, with their competitiveness possibly wiped out by an artificially low margin between Chinese mid-and downstream products released into the western market (Eurometaux, 2019).

**Table 208: Qualitative forecast of supply and demand of tungsten**

Materials	Criticality of the material in 2020		Demand forecast			Supply forecast		
	Yes	No	5 years	10 years	20 years	5 years	10 years	20 years
Tungsten	X		?	?	?	?	?	?

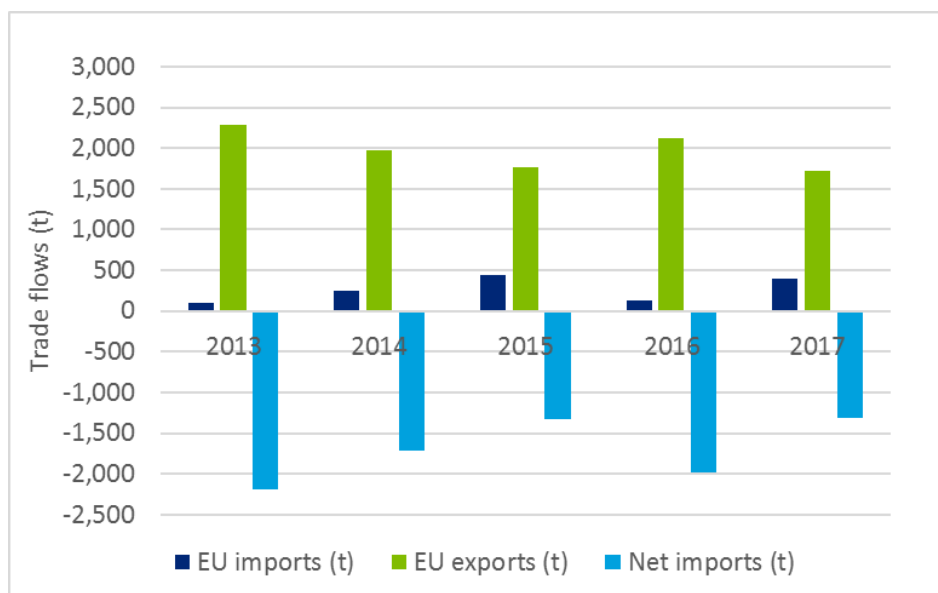
### 27.2.2 EU trade

According to the data reported by Eurostat-Comext database, on average between 2013 and 2017<sup>283</sup>, the EU imported 208 tonnes tungsten content per year of tungsten ores and concentrates. However, the reliability of import figure for tungsten reported in Eurostat-Comext (2019) has been questioned by experts. For commercial confidentiality reason, the real figures related to import statistics of the customs authorities were not reported, as for the case of Austria, one of the most important tungsten producing and importing countries in the EU (Eurometaux, 2019). The import of Austria was estimated to be much higher than indicated in these figures which consequently would have resulted in a positive net import. Due to such limitation, the EU import reliance, apparent consumption, and supply risk of tungsten could not be estimated.

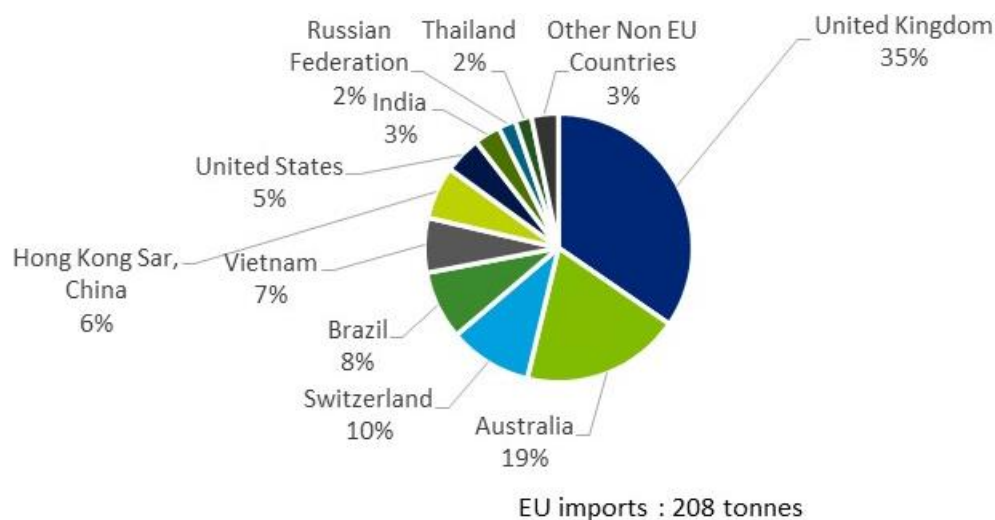
Portugal produces wolframite concentrate from the Panasqueira Mine and beneficiation plant in central Portugal. The wolframite concentrate produced from Panasqueira is sent to the United

<sup>283</sup> 2012 excluded, as not representative

States, Japan and elsewhere to be processed (USGS, 2016b). According to the data from USGS (2019b), Spain is one of the major suppliers of tungsten ores and concentrates to the United States. The mass balance between the production of Spain and trade with the United States suggests that most of tungsten ores and concentrates production from Spain was exported to the United States.



**Figure 489: EU trade flows for tungsten ores and concentrates in t of tungsten content (Eurostat, 2019) – incomplete figure for Austria due to confidentiality reason (Eurometaux, 2020)**



**Figure 490: EU imports<sup>284</sup> of tungsten ores and concentrates, 2013-2017 (data source: Eurostat, 2019a) – incomplete figure for Austria due to confidentiality reason (Eurometaux, 2020)**

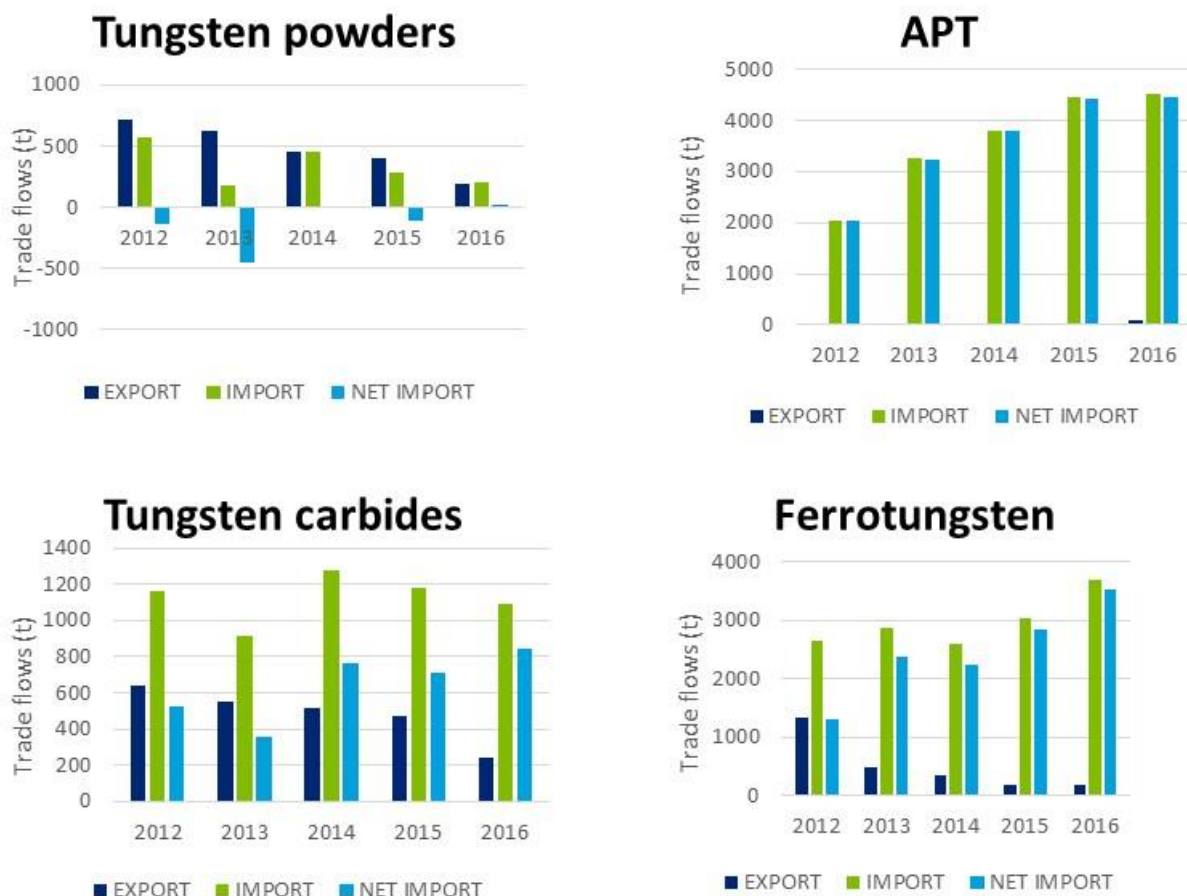
Figure 491 presents the trade flow of various processed tungsten products from 2012-2016. At processing stage, the EU is a net importer of tungsten powders, ammonium paratungstate (APT), tungsten carbides, and ferrotungsten. The average 2012-2016 annual EU import was 340 tonnes

<sup>284</sup> Except for 2012, EU is a net exporter of tungsten ores and concentrates, therefore the picture of importer countries is of limited relevance.

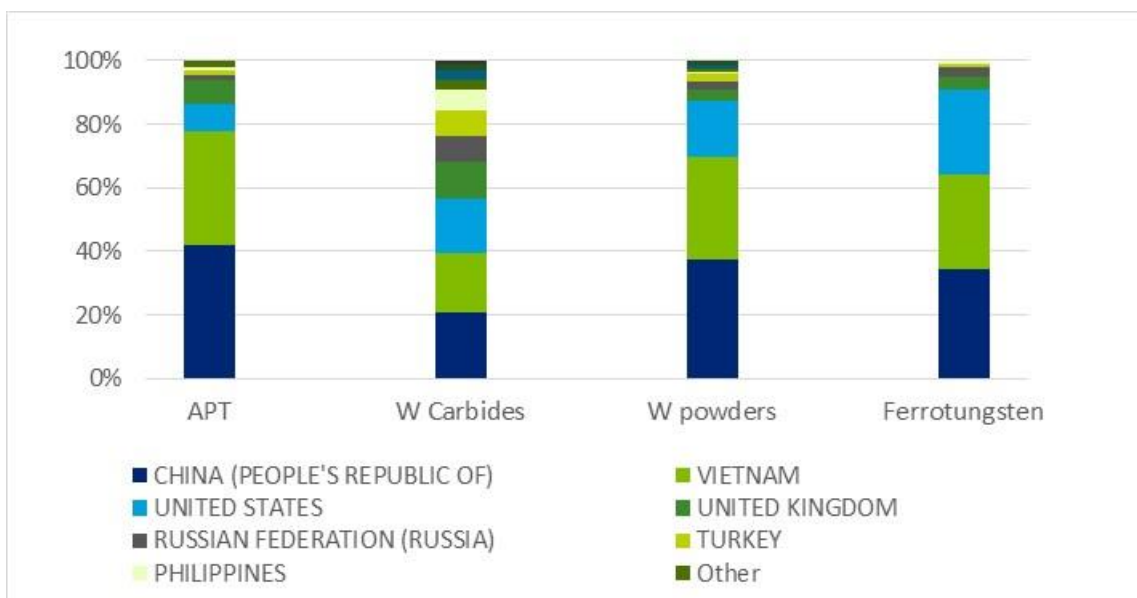
per year for tungsten powder, 3,619 tonnes per year for APT, 1124 tonnes per year for carbides of tungsten, and 2,969 tonnes per year for ferrotungsten.

The main EU suppliers for these products are shown in Figure 491, among which China, Vietnam, and the United States.

According to experts (SCRREEN workshops, 2019), some companies have officially withheld from reporting trade figures for tungsten intermediates due to confidentiality reason. Hence, trade figures have to be interpreted carefully since they may not give a complete picture of the trade situation, nor the apparent consumption in the EU.



**Figure 491: EU trade flows for processed tungsten 2012-2016 (Data source: Eurostat, 2019a)**

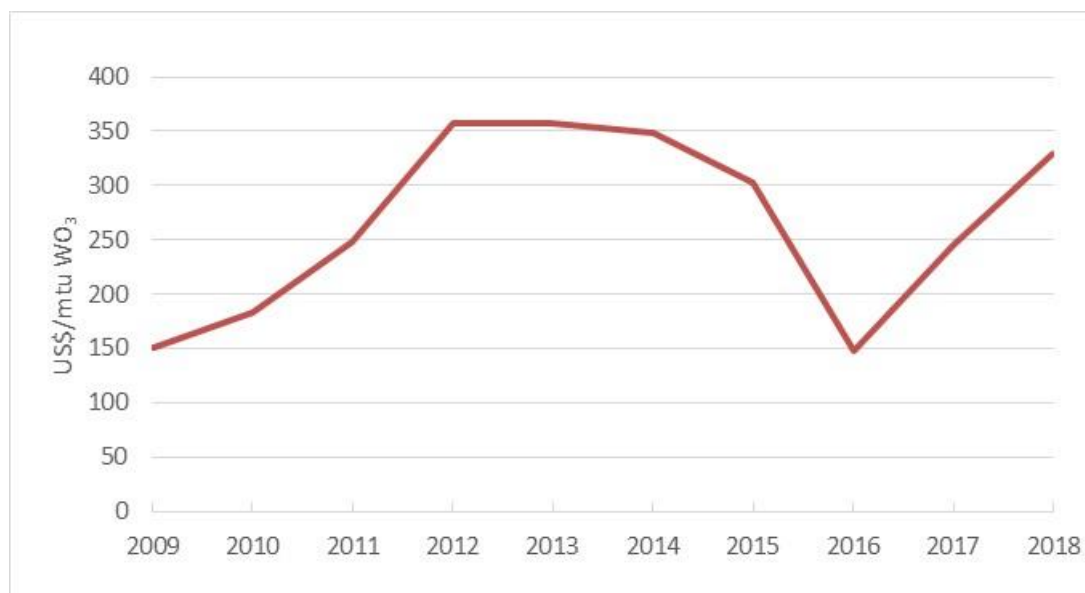


**Figure 492: The share of EU suppliers of: APT, tungsten carbides, tungsten powders, and ferrotungsten (average 2012-2016)**

### 27.2.3 Prices and price volatility

Figure 493 and Figure 494 display the price trend of tungsten and tungsten products from two different sources, covering the prices of tungsten concentrates at the US spot market, tungsten concentrates in China, the prices of ammonium paratungstate (APT) and ferrotungsten in the EU. Both figures show the increasing prices of tungsten post-economic crisis in 2009 until 2011, followed by a gradual decrease until their lowest in 2016.

Prices for concentrates, APT, and ferrotungsten seemed to recover in 2017 and 2018.



**Figure 493: Tungsten prices, US spot market (USD/mtu) between 2009 and 2018. (USGS, 2019)**



Figure 494: APT prices in \$ as mtu (=10kg) of WO<sub>3</sub> contained in APT. (ITIA, 2019)

## 27.3 EU demand

### 27.3.1 EU demand and consumption

The EU's average annual demand for tungsten (concentrates and tungsten products) over the period 2012-2016 was estimated at 10,010 tonnes per year (of W content). The EU's demand was higher, at 14,250 tonnes in 2018, by far the highest since the global economic crisis in 2009 (ITIA, 2019). In the period of 2012-2016, the EU's demand represents about 12% of the world consumption, and is the second market after China (that consumes half of the tungsten available worldwide).

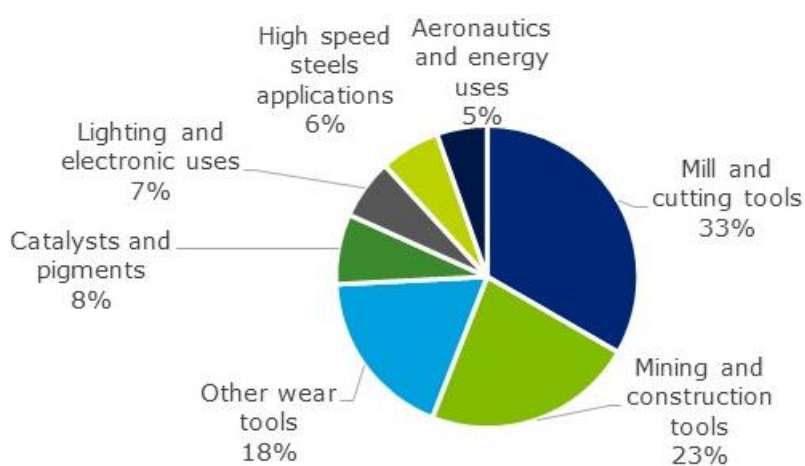
Criticality assessment 2017 mentioned the discrepancy between the estimation of EU sourcing for primary tungsten compared to the figure of primary tungsten demand announced by the International Tungsten Industry Association (ITIA). This difference can be explained by the fact that industrial experts have raised the issue of the absence of some important EU suppliers, such as Canada and Rwanda, in the Comext figures used in the assessment (European Commission, 2017).

### 27.3.2 Uses and end-uses of tungsten in the EU

Due to its exceptional physical properties, tungsten is used for a wide range of applications. The largest share is used for the production of cemented carbides. The rest is used for fabricated products, alloy steels, super alloys and tungsten alloys. The majority of tungsten is used for hard metals, whose main component is tungsten carbide (WC). They are characterized by high wear resistance even at high temperatures. Therefore hard metals are used for cutting and drilling tools. Similar properties arise from the addition of tungsten to steel. The widest range of applications is represented by tungsten alloys. They are used in lighting technology, electrical and electronic technology, high-temperature technology (e.g. furnaces, power stations), welding, spark erosion, space travel and aircraft devices, armaments and laser technology.

The end-use of tungsten has not changed greatly from the previous assessment . The tungsten consumed in the EU for the manufacture of the following products (Bio Intelligence Service, 2015; SCRREEN, 2019):

- 67% of tungsten consumed in the EU is used for the manufacturing of tungsten carbides. Tungsten cemented carbides, or hardmetals, are materials made by "cementing" very hard tungsten monocarbide grains in a binder matrix of a tough cobalt or nickel alloy by liquid phase sintering. Cemented carbides combine high hardness and strength with toughness and plasticity. Tungsten carbide is the most metallic of the carbides, and by far the most important hard phase. Due to those characteristics, tungsten carbides are used in mill and cutting tools, as well as in mining and construction tools. Other tools (wear resistance, mirrors, forming tools) are made of tungsten carbides.
- 11% of tungsten consumed in the EU is used for the manufacturing of tungsten metal. Tungsten metal is used for the manufacture of fabricated products in the lighting and electronic industry. The lamp industry covers incandescent bulb filament containing W, compact fluorescent lamp, and high intensity discharge lamp HID. In the electronic & electrical industry, tungsten metal is used as an electron emitter in integrated circuits, and also in X-ray tubes.
- 3% of tungsten consumed in the EU is used for the manufacturing of tungsten alloys
- 8% of tungsten consumed in the EU is used for the manufacturing of tungsten containing steels
- 11% of tungsten consumed in the EU is used for the manufacturing of chemical applications.



**Figure 495: End uses of tungsten, 2012-2016 (SCRREEN, 2019).**

Relevant industry sectors are described using the NACE sector codes (Eurostat, 2019b), presented in Table 209.

**Table 209: Tungsten applications, 2-digit and associated 6-digit NACE sectors, and value added per sector (Eurostat, 2019b)**

<b>Applications</b>	<b>2-digit NACE sector</b>	<b>4-digit NACE sectors</b>	<b>Value added of NACE 2 sector (millions €)</b>
Mill and cutting tools	C28 - Manufacture of machinery and equipment n.e.c.	C2841- Manufacture of metal forming machinery	182,589
Mining and construction tools	C28 - Manufacture of machinery and equipment n.e.c.	C2892- Manufacture of machinery for mining, quarrying and construction	182,589
Other wear tools	C28 - Manufacture of machinery and equipment n.e.c.	C2849- Manufacture of other machine tools	182,589
Catalysts and pigments	C20 - Manufacture of chemicals and chemical products	C2012- Manufacture of dyes and pigments; C2059- Manufacture of other chemical products n.e.c.	105,514
Lighting and electronic uses	C26 - Manufacture of computer, electronic and optical products	C2611- Manufacture of electronic components	65,703
High speed steels applications	C25 - Manufacture of fabricated metal products, except machinery and equipment	C2562- Machining	148,351
Aeronautics and energy uses	C28 - Manufacture of machinery and equipment n.e.c.	C2811- Manufacture of engines and turbines, except aircraft, vehicle and cycle engines; C2812- Manufacture of fluid power equipment; C3030- Manufacture of air and spacecraft and related machinery	182,589

### **27.3.3 Substitution**

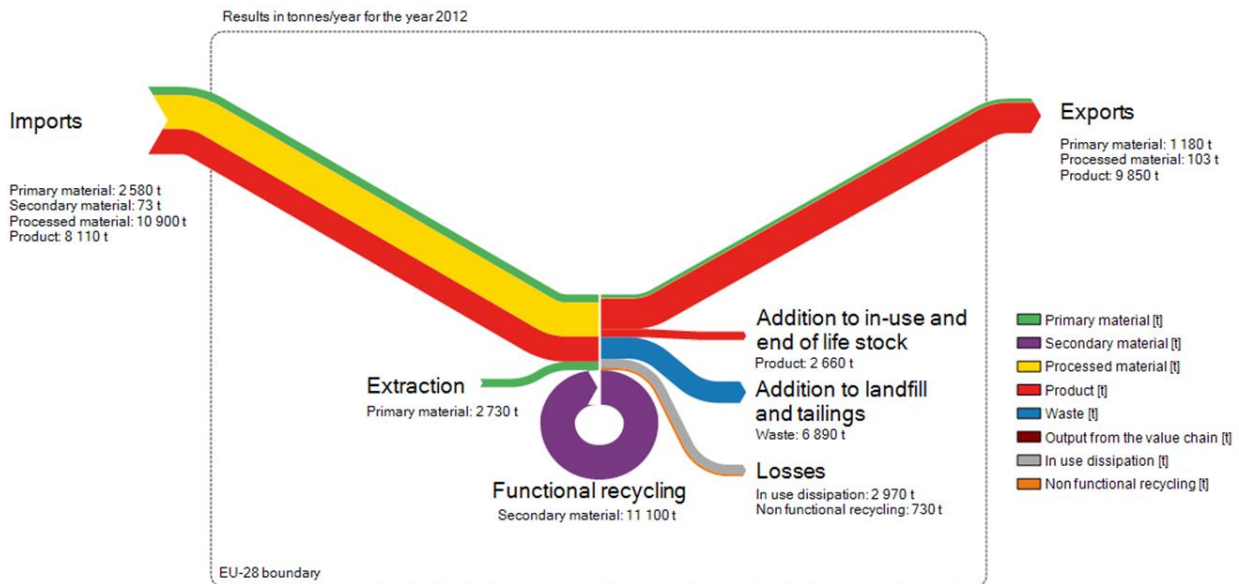
Tungsten has very special performance and is most of the time the best choice of material. Therefore, very low-performing substitution exists for this material in the industrial reality.

The consumption of tungsten continues to increase as the amount of carbide tool production increases with the expansion of markets in developing countries. Potential substitutes for cemented tungsten carbides include cemented carbides based on molybdenum carbide, niobium carbide, or titanium carbide; ceramics; ceramic-metallic composites (cermets); and tool steels (USGS 2019). For tungsten carbide-based cemented carbides, substitution appears to be technically possible but implies higher costs and a decrease in performance in some cases. Titanium carbides (TiC) and titanium nitride (TiN) are potential substitute but the technology is not competitive at the moment. Tungsten can be replaced by other refractory metals such as niobium (critical in 2020) or molybdenum in steel products. In other application areas, possible substitution of tungsten is affordable, for example super-alloys substituted by Ceramic Matrix Composites (CMCs) made from a silicon carbide/nitride matrix for gas turbine engines. Substitution with nanostructured n-alloys such as FeTa, could be possible in 10 years since current TRLs are very low (TRL 3-4). Substitution in the lighting sector is well underway (Bilewska et al. 2016; Pavel et al. 2016c; Tercero Espinoza et al. 2015).

## 27.4 Supply

### 27.4.1 EU supply chain

- In Europe, during the period 2012-2016 the extraction of primary tungsten ores and concentrates took place in Austria, Spain, and Portugal.
- At processing stage, the EU also has the capacity to process tungsten ores and concentrates into tungsten-based products. ITIA identified at least two tungsten ores and concentrates processing facilities in the EU, one located in Austria and one located in Germany. While the EU demand for ammonium paratungstate (APT) and tungsten carbides is supplemented by imports, ferrotungsten is entirely supplied from imports.
- Regarding secondary source of tungsten, recycling in the EU is generally strong. Tungsten scrap was estimated to be re-used in Europe, at a rate between 45-50% (Baylist, 2014 and ITIA, 2018). Recent figures from ITIA mentioned 8,800 tonnes of recycled tungsten generated in the EU in 2018 (ITIA, 2019).



**Figure 496: Simplified diagram of material system analysis of tungsten in the EU27+the UK, for the year 2012 (Bio Intelligence Service, 2015)**

### 27.4.2 Supply from primary materials

#### 27.4.2.1 Geology, resources and reserves of tungsten

##### Geological occurrence:

The average abundance of tungsten in the Earth's crust is estimated to be 1.25-1.50 ppm (BGS, 2011), and its concentration in the upper crust is  $3.3 \pm 1.1$  ppm (Rudnick, 2003). In nature, tungsten does not occur as free metal but in 45 different minerals, of which only two, wolframite and scheelite, have any economic importance. Tungsten minerals often occur as monotungstates, such as scheelite (calcium tungstate,  $\text{CaWO}_4$ ), stolzite (lead tungstate,  $\text{PbWO}_4$ ), and wolframite. Wolframite is a solid solution of ferberite (ferrous tungstate,  $\text{FeWO}_4$ ) and hübnerite (manganous tungstate,  $\text{MnWO}_4$ ) (BGS, 2011). Scheelite is the most abundant tungsten mineral and is present in approximately two-thirds of known tungsten deposits (BGS, 2011).



### Global resources and reserves<sup>285</sup>:

World tungsten known resources are estimated at 7 million tonnes of contained tungsten metal (BGS, 2011; USGS, 2019). World tungsten resources are geographically widespread. Major tungsten deposits are located in China, Canada and Russia. Canada, Kazakhstan, Russia, and the United States also have significant resources (USGS, 2019).

According to USGS (2019), world known reserves of tungsten is estimated at 3.3 million tonnes of contained tungsten metal, with more than 57% of these located in China.

**Table 210: Global reserves of tungsten (Data source: USGS, 2019)**

Country	Tungsten Reserves (tonnes of tungsten content)
United States	NA
Austria	10,000
Bolivia	NA
Canada	290,000
China	1,900,000
Portugal	2,700
Russia	83,000
Rwanda	NA
Spain	32,000
United Kingdom	51,000
Vietnam	95,000
Other countries	680,000

**EU resources and reserves<sup>286</sup>:** Resource information for Spain, Portugal, Poland, Slovakia, Czechia are available at Minerals4EU (2019) (see Table 211) but cannot be summed as they are partial and they do not use the same reporting code. About 500,000 tonnes of tungsten are contained in EU known resources according to the MSA study, estimated by contacting several geological survey in EU member states (Bio Intelligence Service, 2015). According to industry experts, there are more deposits known or ready to be developed in Europe, such as Hemerdon

---

<sup>285</sup> There is no single source of comprehensive evaluations for resources and reserves that apply the same criteria to deposits of tungsten in different geographic areas of the EU or globally. The USGS collects information about the quantity and quality of mineral resources but does not directly measure reserves, and companies or governments do not directly report reserves to the USGS. Individual companies may publish regular mineral resource and reserve reports, but reporting is done using a variety of systems of reporting depending on the location of their operation, their corporate identity and stock market requirements. Translations between national reporting codes are possible by application of the CRIRSCO template.<sup>285</sup>, which is also consistent with the United Nations Framework Classification (UNFC) system. However, reserve and resource data are changing continuously as exploration and mining proceed and are thus influenced by market conditions and should be followed continuously.

<sup>286</sup> For Europe, there is no complete and harmonised dataset that presents total EU resource and reserve estimates for tungsten. The Minerals4EU project is the only EU-level repository of some mineral resource and reserve data for tungsten, but this information does not provide a complete picture for Europe. It includes estimates based on a variety of reporting codes used by different countries, and different types of non-comparable datasets (e.g. historic estimates, inferred reserves figures only, etc.). In addition, translations of Minerals4EU data by application of the CRIRSCO template is not always possible, meaning that not all resource and reserve data for tungsten the national/regional level is consistent with the United Nations Framework Classification (UNFC) system (Minerals4EU 2019). Many documented resources in Europe are based on historic estimates and are of little current economic interest. Data for these may not always be presentable in accordance with the UNFC system. However a very solid estimation can be done by experts.

deposit (UK) that led to a mine opening in 2016, Barruecopardo (Spain) which has already financing in place, and some work is done at La Parilla (Spain) (Wolfram, 2016).

**Table 211: Resource data for the EU compiled in the European Minerals Yearbook of Minerals4EU (Minerals4EU, 2019)**

Country	Reporting code	Quantity	Unit	Grade	Code Resource Type
Spain	NI 43-101	615	kt	0.0032% WO <sub>3</sub>	Measured
Portugal	NI 43-101	1495	Mt	0.55% WO <sub>3</sub>	Indicated
Poland	Nat. rep. code	0.24	Mt	0.04% W	C2+D
Slovakia	none	2846	Mt	0.23% W	-
Czech Republic	Nat. rep. code	70.2	kt	0.8% W	Potentially economic

In the EU, an estimated of 80,000 tonnes of tungsten reserve were identified by several EU geological surveys (Bio Intelligence Service, 2015). Similarly to resource, quantitative information on tungsten reserve for some countries in Europe are available in the Minerals4EU website but cannot be summed as they are partial and they do not use the same reporting code.

To date, there has not been any new information referring to EU resources and reserves of tungsten at Minerals4EU (2019).

In 2018, Lauri et al. (2018) reported tungsten occurrences in the following EU member states:

- Austria: an estimated quantity of 24,000 tonnes of tungsten resources was reported at the Mittersill mine
- Finland: 17 occurrences with tungsten as main commodity and 6 occurrences with tungsten as minor commodity were listed in the FODD database. Four deposits have a non-compliant resource estimate of 2,333 tonnes of tungsten metal
- France: 15 tungsten deposits with an estimated resource quantity of 66,000 tonnes and 100 occurrences without resources data.
- Greece: One medium-sized tungsten deposit with a non-compliant resource of 6,000 tonnes of tungsten.
- Portugal: The resources (including reserves) at Panasqueira mine were estimated to be 27,240 tonnes of tungsten at the end of 2016. At S. Pedro da Águias (Tabuaço), there is an indicated resource of 0.76 Mt with 0.58 % WO<sub>3</sub> and inferred 1.33 Mt at 0.57% WO<sub>3</sub>, accounting for a total estimate of 9,500 tonnes of tungsten content. The ProMine database lists eight closed tungsten mines for Portugal; jointly these are reported to contain resources of nearly 40,000 t W. In addition, there are six tungsten occurrences without resource data in the ProMine database.
- Spain: A total resource of 15,334 tonnes of tungsten metal was estimated at Los Santos and 15,400 tonnes fo Valtreixal in 2015. In addition, an estimated of 21,800 tonnes of tungsten resources, 15 closed mines and other occurrences without resource information were listed for Spain in ProMine database.
- Sweden: Non-compliant resource estimates are available for three W occurrences that have not been exploited. Two of these give information on the tungsten content of the ore, with a total of 2.1 Mt of tungsten-bearing ore at 0.2 % of W.
- Bulgaria, Czechia, Germany, Ireland, Italy: occurrences of tungsten were reported with no available information on the resource quantity.

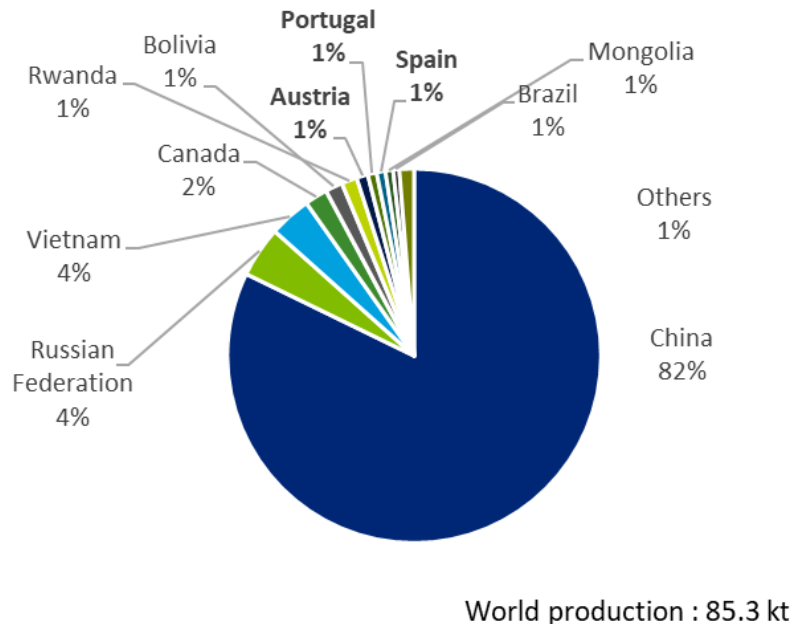
### 27.4.2.2 World and EU mine production

Mining of tungsten is performed through both open-pit mining and underground mining. The ore from mine is crushed and milled, and then upgraded by means of gravity enrichment or flotation. For commercial trading 65-75% WO<sub>3</sub> content is required for further refining (European Commission, 2014). The ore beneficiation allows to increase the tungsten content of the concentrate up to 65-75% WO<sub>3</sub>, which can be (BGS, 2011):

- directly used for production of ferrotungsten or steel manufacture, or
- converted by hydrometallurgy into intermediate tungsten compounds (APT or tungsten oxides), or
- further refined by pyrometallurgy into pure tungsten (metal, carbide, alloys, etc.).

The global production of tungsten concentrates amounts about 85,300 t (in W content) annually over the years 2012-2016 (WMD, 2019). In average between 2012 and 2016, about 82% of the world's tungsten production came from China (WMD, 2019). To provide the domestic industry with a target and to manage the country's natural resources in a way to balance supply and demand, China imposed a tungsten mining quota in 2002. Since the introduction, the amount of the quota has increased from 43,700 t concentrate of 65% WO<sub>3</sub> in 2002 to 100,000 t in 2018 (ITIA, 2019). However, despite the quota, Chinese production has been stable from 2012 to 2016.

From 2014, Vietnam went from a medium-scale to the world's second largest producer of tungsten concentrates outside China by the opening of the Nui Phao mine in 2013 (about 4000 tonnes in 2014 and more in 2016). In contrast, Canada will be "zero" from 2016 onwards, due to the closure of the Cantung mine in late 2015 (Wolfram, 2016).

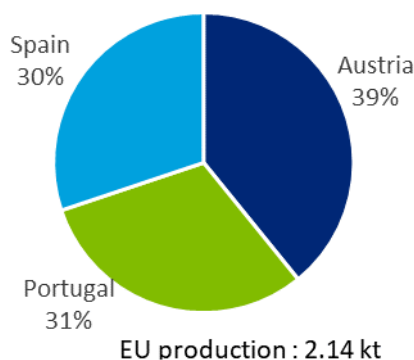


**Figure 497: Global mine production of tungsten ores and concentrates in tonnes and percentage. Average for the years 2012-2016. (WMD, 2019)**

Tungsten extraction in the EU is exclusively located in Austria, Portugal and Spain and represents around 2,140 t of tungsten content, i.e 3% of the global extraction.

In 2016, a tungsten mine in England was opened. Due to a combination of technical problems and depressed prices, this mine stopped in late 2018 and will likely not be producing in the foreseeable future. The Los Santos mine in Spain ceased mining in 2019, but minor production is maintained by retreating old tailings. In total, this accounts for a loss of over 4000 t of (planned) production in Europe (Eurometaux, 2019).

The concentrate facility of Barruecopardo mine (Salamanca), Spain, formerly active until 1991, obtained a licence to operate in September 2019. The first WO<sub>3</sub> production is expected to be put on the market in 2019. A new project in Spain, owned by Valtreixal Resources Spain, SL (Almonty Group), has recently obtained a research permit, and currently conducting a Environmental Impact Assesement (Marchan, 2019).



**Figure 498: EU mine production of tungsten ores and concentrates in tonnes and percentage. Average for the years 2012-2016. (WMD, 2019)**

### 27.4.3 Supply from secondary materials/recycling

Secondary tungsten can be found in two main types of sources: in waste from processing the material containing niobium as well as in end of life products from urban mines and manufacturing residues (Sundqvist Oeqvist, Pr. Lena et al. ,2018). Tungsten scrap, due to its high tungsten content in comparison to ore, is a very valuable source.

Several research projects to recover tungsten have been developed in the EU, for example:

- Recovery of tungsten from spent selective catalytic reduction (SCR) catalysts used in chemical industry. A method used to recover tungsten includes pressure leaching reaction with soda digestion process, using NaOH as leaching agent. The obtained solution contained tungsten and vanadium. The method proved to successfully recover both metals (Witold Kurylak, 2016).
- Recovery of tungsten from wastewater of PCB. Although used in minor quantities, tungsten can be traced in printed circuit boards (PCB), used in wiring, contacts, electrode emitters and heat sinks. The process used to recover tungsten is called emulsion liquid membrane (ELM) and is commonly used to separate metal ions and also hydrocarbons or biological compounds. The technology is still at early stage of development, but the tests results has shown, that the separation of W from wastewater is possible (Sundqvist Oeqvist, Pr. Lena et al. ,2018).

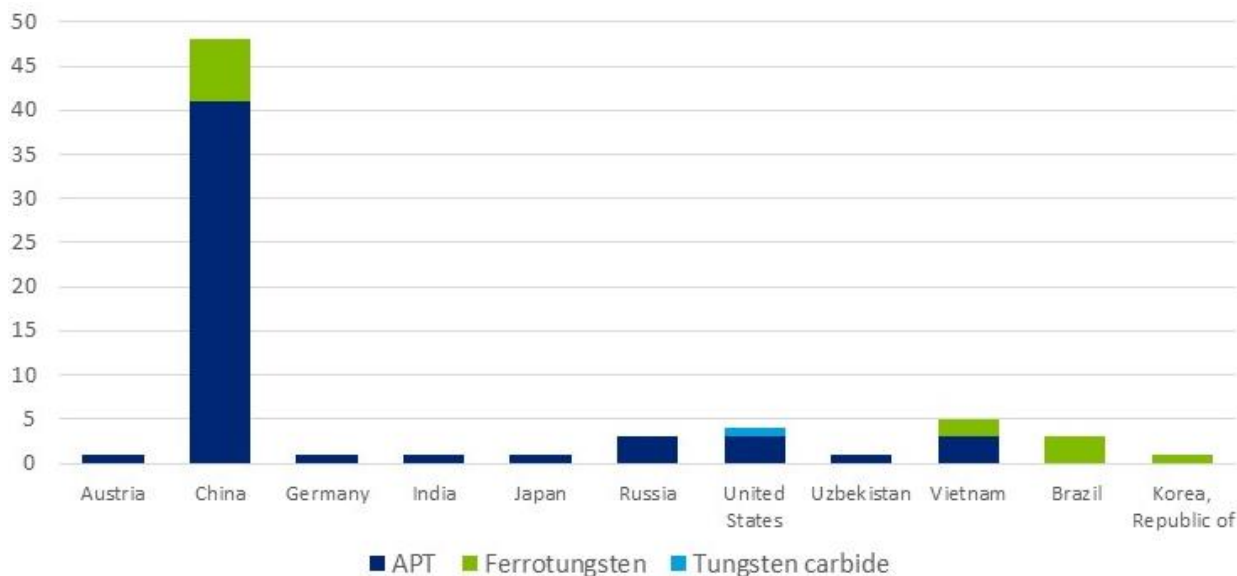
The recycling activities inside Europe have considerably increased since the global economic crisis in 2009. Experts reported a recycling rate for tungsten in the EU as high as 45-50%. The recycling input rate from new and old scrap for tungsten was estimated at 35%. Experts estimated end-of-life recycling rate as high as 30% (ITIA, 2018).

Based on the material flow analysis performed in the MSA study, a 42% End of Life Input-Recycling-Rate (EoL-RIR) has been estimated (Bio Intelligence Service, 2015). This is consistent with Roskill’s estimate of secondary tungsten (scrap re-use) that reached 50% in 2013 in Europe (Baylis, 2014), but a little higher than ITIA’s estimate of 30% (ITIA, 2018). These values are higher than the old estimates made by UNEP in 2011 of 10-25% of end-of-life recycling; with secondary tungsten representing 34% of supply (10% from new scrap and 24% from old scrap) (UNEP, 2011). In this criticality assessment, the value resulted from MSA study (42% of EoL-RIR) was used.

### 27.4.4 Processing of Tungsten

There is no official data on the production of processed tungsten. Figure 499 shows the number of companies that are known to be the global consumer of tungsten ores and concentrates identified by the International Trade Administration (ITA, 2018). Most of smelters of tungsten are located in China.

In the EU, tungsten smelters are located in Austria and Germany, both process tungsten ores and concentrates into mainly ammonium paratungstate. Despite the lack of quantitative data on the production capacity of each country, Figure 499 indicates the domination of China in the mid-downstream of tungsten supply chain (ITA, 2018).



**Figure 499: Number of identified global consumers of tungsten concentrates in 2017 (ITA, 2018)**

## 27.5 Other considerations

---

### 27.5.1 Environmental and health and safety issues

Chronic inhalation or severe exposure to airborne tungsten dust particles and ingestion of large amounts of soluble tungsten compounds is known to be hazardous to human health (BGS, 2011).

However, tungsten and its compounds are not actually concerned by REACH, except nickel tungstate (NiWO<sub>4</sub>) cited as carcinogen in the Appendix 1 of Annex XVII as nickel compound. In addition, the cemented tungsten carbide sector will be seriously impacted by upcoming reclassification of tungsten carbide-Cobalt compounds (presence of cobalt as binder) in REACH (WKO, 2016). The substitution products will be less performing, more expensive and not necessarily more health and/or environment friendly (WKO, 2016).

### 27.5.2 Socio-economic issues

The Regulation of the European Parliament and of the Council sets up a Union system for supply chain due diligence self-certification in order to curtail opportunities for armed groups and unlawful security forces to trade in tin, tantalum and tungsten, their ores, and gold. It will take effect on 1<sup>st</sup> January 2021. It is designed to provide transparency and certainty as regards the supply practices of importers, (notably smelters and refiners) sourcing from conflict-affected and high-risk areas. The EU regulation covers tin, tantalum, tungsten, and gold because these are the four metals that are most mined in areas affected by conflict or in mines that rely on forced labour.

The regulation also draws on well-established rules drawn up by the Organisation for Economic Co-operation and Development (OECD) in a document called 'Due Diligence Guidance for Responsible Supply Chains from Conflict-Affected and High-Risk Areas.' The regulation only applies directly to EU-based importers of tin, tantalum, tungsten and gold, whether these are in the form of mineral ores, concentrates or processed metals.

## 27.6 Comparison with previous EU assessments

---

The results of this and earlier assessments are shown in Table 212. Supply risk has been analysed at both mine and processing stages.

**Table 212: Economic importance and supply risk for tungsten in the assessments of 2011, 2014, 2017, 2020 (European Commission, 2011-2014-2017)**

Assessment	2011		2014		2017		2020	
	EI	SR	EI	SR	EI	SR	EI	SR
Tungsten	8.75	1.81	9.05	1.99	7.3	1.8	8.12	1.61

The economic importance of tungsten has changed between 2012-2016 due to the change in the added value of the sector for which tungsten is relevant.

The assessment of supply risk of tungsten was challenged by the lack of reliable data in both mine and processing stage. In assessing the EU supply risk of tungsten ores and concentrates, export and import figure from Eurostat-Comext were reported. The reported import figures, for example, were considered underestimated by experts, due to confidentiality issue. Therefore, a reliable value of supply risk at mining stage could not be obtained.

At processing stage, apart from the complex nature of supply chain of tungsten, no data on the global supply of processed tungsten was available. The figure of the EU import and export of processed tungsten for EU supply risk calculation was available in Eurostat Comext. Similar to the figure of tungsten ores and concentrates, due to confidentiality reason, the figures reported in Eurostat-Comext may not reflect the reality in the EU.

The United States International Trade Administration (ITA) identified a list of companies known to be consumers of tungsten ores and concentrates. The list was not accompanied by production capacity information, therefore it can not be used as a proxy of the concentration of processed tungsten production globally. Nevertheless, the figure clearly suggests the domination of China, which was confirmed by experts. Therefore, the final score for supply risk in Table 212, is a result of the global supply risk based on the distribution of tungsten smelters worldwide.

## **27.7 Data sources**

---

The credibility of the EU import figure for tungsten in Eurostat-Comext database has been questioned by experts. Import has been said to be underestimated; this is however due to the confidentiality issue. For this reason, a reliable figure of EU apparent consumption and EU import reliance of tungsten ores and concentrates could not be calculated. EU import and export of processed tungsten was available in Eurostat Comext. On the other hand, the data on global supply of processed tungsten was not available. The distribution of tungsten smelters and refiners have been used as a proxy of the supply concentration.

### **27.7.1 Data sources used in the factsheet**

Baylis R, Roskill (2014). Tungsten: Market review 2014. ITIA AGM 2014 Toronto, Canada September 2014

BGS (2011). Tungsten Profile. [online] Available at: <http://www.bgs.ac.uk/mineralsuk/statistics/mineralProfiles.html> [Accessed September 2016]

Bio Intelligence Service (2015). Study on Data for a Raw Material System Analysis: Roadmap and Test of the Fully Operational MSA for Raw Materials – Final Report. Prepared for the European Commission, DG GROW. p 41-43

Eurometaux (2019). Communication after the workshop held in Brussels on 11/10/2019

European Commission (2010). Critical raw materials for the EU. [online] Available at: [https://ec.europa.eu/growth/sectors/raw-materials/specific-interest/critical\\_en](https://ec.europa.eu/growth/sectors/raw-materials/specific-interest/critical_en)

European Commission (2014) Report on critical raw materials for the EU - Critical raw materials profiles. Tungsten profile, p193-202

European Commission (2017). Critical raw materials for the EU. [online] Available at: [https://ec.europa.eu/growth/sectors/raw-materials/specific-interest/critical\\_en](https://ec.europa.eu/growth/sectors/raw-materials/specific-interest/critical_en)

European Parliament (2016). Conflict minerals: MEPs secure mandatory due diligence for importers. Press release - External/international trade – November 2016 [online] Available at: <http://www.europarl.europa.eu/news/en/news-room/20161122IPR52536/conflict-minerals-meps-secure-mandatory-due-diligence-for-importers>

Eurostat (2019)a. International Trade Easy Comext Database [online] Available at: <http://epp.eurostat.ec.europa.eu/newxtweb/>

Eurostat (2019)b. Annual detailed enterprise statistics for industry (NACE Rev. 2, B-E). [online] Available at: [http://ec.europa.eu/eurostat/en/web/products-datasets/-/SBS\\_NA\\_IND\\_R2](http://ec.europa.eu/eurostat/en/web/products-datasets/-/SBS_NA_IND_R2)

International Trade Administration (ITA) (2018). List of identified global consumers of tungsten concentrates 2018. Available at: <https://www.trade.gov/industry/materials/Tungsten101617.pdf>

International Tungsten Industry Association, ITIA (2018a). Presentation "Tungsten industrial importance" at COST CRM extreme Workshop in Brussels, November 2018.

International Tungsten Industry Association, ITIA (2018b). ITIA Newsletter: Recycling of Tungsten; current share, economic limitations and future potential, May 2018.

International Tungsten Industry Association, ITIA (2019). Consultation with Burghard Zeller, October 2019.

Lasser E (1999). Tungsten: properties, chemistry, technology of the elements, alloys, and chemical compounds. Available at: [http://books.google.fr/books?id=foLRISkt9qcC&pg=PA1&source=gbs\\_toc\\_r&cad=3#v=onepage&q&f=false](http://books.google.fr/books?id=foLRISkt9qcC&pg=PA1&source=gbs_toc_r&cad=3#v=onepage&q&f=false)

Lauri, Laura (GTK), Teresa Brown, Gus Gunn (BGS), Per Kalvig (GEUS), Henrike Sievers (BGR). (2018). SCRREEN D3.1. Identification and quantification of primary CRM resources in Europe.

Marchan, Carmen. (2019) Personal communication after AHWG consultation, October 2019 in Brussels.

Minerals4EU (2019). European Minerals Yearbook. [online] Available at: [http://minerals4eu.brgm-rec.fr/m4eu-yearbook/theme\\_selection.html](http://minerals4eu.brgm-rec.fr/m4eu-yearbook/theme_selection.html)

OECD (2019). Export restrictions on Industrial Raw Materials. [online] Available at: <http://qdd.oecd.org/table.aspx?Subject=ExportRestrictionsIndustrialRawMaterials> [Accessed September 2019]

Rudnick, R.L. and Gao. S. (2003). Composition of the Continental Crust. In: Treatise on Geochemistry, Volume 3. Editor: Roberta L. Rudnick. Executive Editors: Heinrich D. Holland and Karl K. Turekian. pp. 659. ISBN 0-08-043751-6. Elsevier, p.1-64

SCRREEN workshop. (2019). "Validation Workshop on Critical Raw Materials, 10-12 September 2019, Thon Hotel Brussels City Centre."

Sundqvist Oeqvist, Pr. Lena et al. (2018). SCRREEN D4.2. Production Technologies of CRM from Primary Resources. Available at: <http://screen.eu/wp-content/uploads/2018/03/SCRREEN-D4.2-Production-technologies-of-CRM-from-secondary-resources.pdf>

UNEP (2011) Recycling rates of Metals - A status Report, A Report of the Working Group on the Global Metal Flows to the International Resource Panel.

USGS (2016)a. Mineral Commodity Summaries: Tungsten. [online] Available at: <https://s3-us-west-2.amazonaws.com/prd-wret/assets/palladium/production/mineral-pubs/tungsten/mcs-2016-tungs.pdf>

USGS (2016)b. Mineral Yearbook: Tungsten. [online] Available at: <https://prd-wret.s3-us-west-2.amazonaws.com/assets/palladium/production/atoms/files/myb1-2016-tungs.pdf>

USGS (2017). Mineral Commodity Summaries: Tungsten. [online] Available at: <https://s3-us-west-2.amazonaws.com/prd-wret/assets/palladium/production/mineral-pubs/tungsten/mcs-2017-tungs.pdf>



USGS (2019)a. Mineral Commodity Summaries: Tungsten. [online] Available at: <https://prd-wret.s3-us-west-2.amazonaws.com/assets/palladium/production/atoms/files/mcs-2019-tungs.pdf>

USGS (2019)b. Mineral Industry Surveys: Tungsten – March 2019. [online] Available at: <https://prd-wret.s3-us-west-2.amazonaws.com/assets/palladium/production/atoms/files/mis-201903-tungs.pdf> - Access date - January 2020

WKO - Austria non-ferrous metals association (2016). Communication.

Wolfram (2016). Communication during the review process.

World Mining Data (2019). Bundesministerium für Nachhaltigkeit und Tourismus. Austrian Federal Ministry of Sustainability and Tourism [online] Available at: <http://www.en.bmwf.gv.at/Energy/WorldMiningData/Seiten/default.aspx>

### **27.7.2 Data sources used in the criticality assessment**

Bio Intelligence Service (2015). Study on Data for a Raw Material System Analysis: Roadmap and Test of the Fully Operational MSA for Raw Materials – Final Report. Prepared for the European Commission, DG GROW. p 41-43

Eurometaux (2019). Communication during the review process.

Eurometaux (2020). Communication during the review process.

European Commission (2017). Critical raw materials for the EU. [online] Available at: [https://ec.europa.eu/growth/sectors/raw-materials/specific-interest/critical\\_en](https://ec.europa.eu/growth/sectors/raw-materials/specific-interest/critical_en)

European Commission (2019). DG Trade website "Agreements", Available at: <http://ec.europa.eu/trade/policy/countries-and-regions/agreements/>

Eurostat (2019)a. International Trade Easy Comext Database [online] Available at: <http://epp.eurostat.ec.europa.eu/newxtweb/>

European Market Access Database, Vietnam: [http://madb.europa.eu/madb/barriers\\_result.htm?isSps=false&countries=VN](http://madb.europa.eu/madb/barriers_result.htm?isSps=false&countries=VN)

International Trade Administration (ITA) (2018). List of identified global consumers of tungsten concentrates 2018. Available at: <https://www.trade.gov/industry/materials/Tungsten101617.pdf>

OECD (2019). Export restrictions on Industrial Raw Materials. [online] Available at: [http://qdd.oecd.org/table.aspx?Subject=ExportRestrictions\\_IndustrialRawMaterials](http://qdd.oecd.org/table.aspx?Subject=ExportRestrictions_IndustrialRawMaterials) [Accessed September 2019]

SCREEN workshop. (2019). Validation Workshop on Critical Raw Materials, 10-12 September 2019, Thon Hotel Brussels City Centre.

UNEP (2011) Recycling rates of Metals - A status Report, A Report of the Working Group on the Global Metal Flows to the International Resource Panel.

Wolfram (2016). Communication during the review

WKO - Austria non-ferrous metals association (2016). Communication

World Mining Data (2019). Bundesministerium für Nachhaltigkeit und Tourismus. Austrian Federal Ministry of Sustainability and Tourism [online] Available at: <http://www.en.bmfwf.gv.at/Energy/WorldMiningData/Seiten/default.aspx>

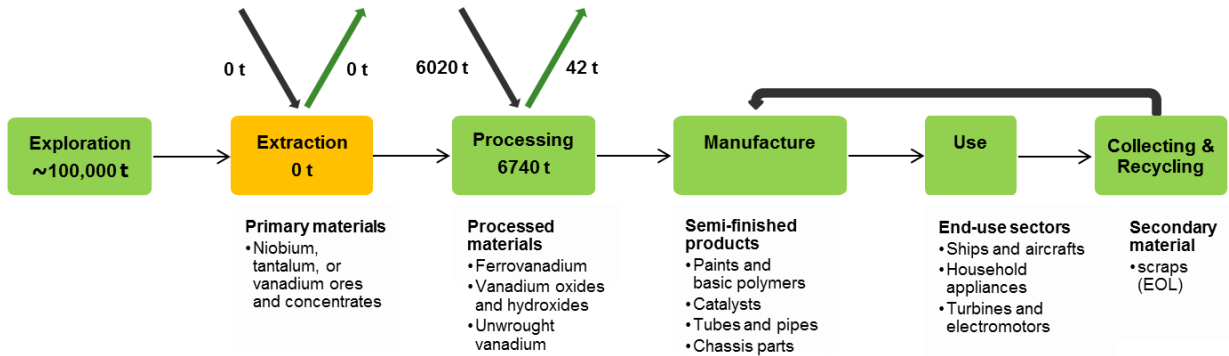
## **27.8 Acknowledgments**

---

This factsheet was prepared by the JRC. The authors would like to thank SCRREEN expert network, the EC Ad Hoc Working Group on Critical Raw Materials and all other relevant stakeholders for their contributions to the preparation of this Factsheet, especially to Eurometaux and the International Tungsten Industry Association.

# 28 VANADIUM

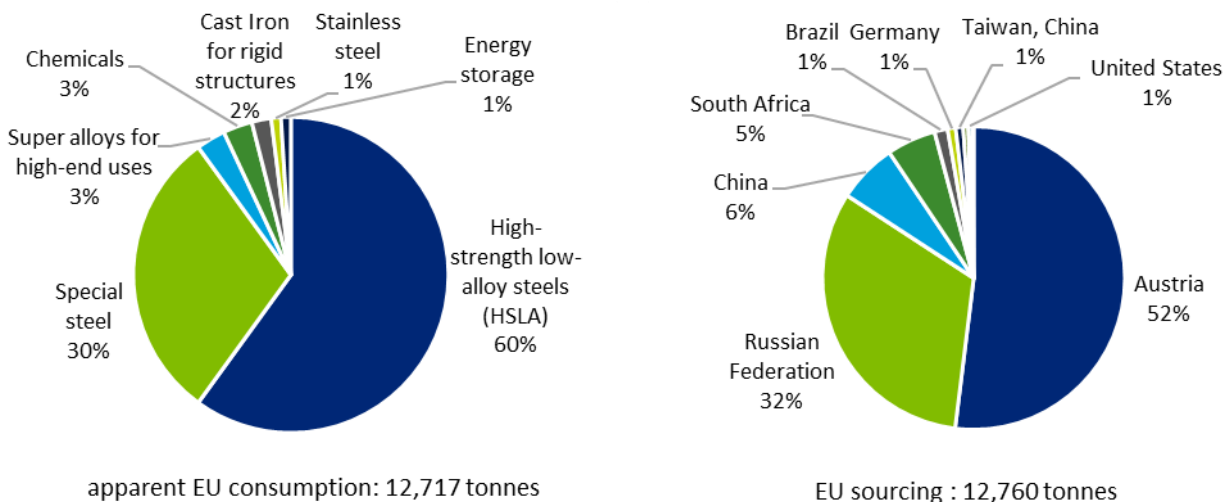
## 28.1 Overview



**Figure 500: Simplified value chain for vanadium in the EU<sup>287</sup>, 2012-2016**

Vanadium (chemical symbol V) is a steel-grey, bluish, shimmering and ductile metallic element with the atomic number 23 and a density of 6.11 g/cm<sup>3</sup>. Its melting point is 1,910 °C and its boiling point is 3,407 °C. Vanadium occurs in many minerals and is basically obtained as a by-product from the production of steel. Vanadium's earliest use was in 1903, when vanadium-alloyed steel was produced. Vanadium resists corrosion due to a protective film of oxide on the surface. Its main application is as an additive in steel and titanium alloys alloy steels to improve their strength and resistance to corrosion, as well as a catalyst for chemicals (BGS, 2015).

For the purpose of this assessment, vanadium is evaluated at both extraction and processing stage. At mine stage, vanadium is assessed as ore/concentrate (CN8 code 2615 90 90). At processing stage, vanadium compounds are assessed, namely the code "vanadium oxides and hydroxides" (CN8 code 2825 30 00), in the form of V<sub>2</sub>O<sub>5</sub> (56% vanadium content). (Eurostat, 2019).



**Figure 501: End uses (Atlantic, 2016) and EU sourcing of vanadium (processing stage), average 2012-2016 (Eurostat, 2019; TTP)**

<sup>287</sup> JRC elaboration on multiple sources (see next sections)

The global market is highly concentrated. Application of vanadium in the vanadium redox battery (close to 2,000 tonnes of vanadium world demand in 2016) is rapidly growing. Some analysts predicted demand for vanadium in this battery type for mass storage of energy (solar, wind) could increase to over 10,000 tonnes per year until circa 2021 (SWEREA, 2016). Demand for vanadium in the EU is projected to increase in all sectors (steel, titanium, chemicals and energy storage), especially driven by increased steel production, compounded by an increasing unit consumption of vanadium per ton of steel (SWEREA, 2016). The majority of ferrovanadium is traded at the open market.

The prices of vanadium are reported to be influenced by production process management costs, rather than by markets and trade developments. Over the last fifteen years, vanadium is one of the materials that have witnessed the greatest price volatility (European Commission, 2017), in spite of relative stable demand levels (55,000-65,000 tonnes per year) in this period. Also recently, in the period May 2018 to April 2019, vanadium showed the highest price volatility (60%) of all materials monitored by DERA, with an upward trend (DERA, 2019b).

The EU does not mine and not import significant amounts of vanadium in ores. At the processing stage, the EU is a net importer of vanadium (oxides), with an EU import reliance of 47%. The average apparent EU consumption of vanadium (vanadium ores) is around 12,700 tonnes per year between 2012 and 2016. The amount of vanadium imported in the shape of oxides<sup>288</sup> to the EU is 6,020 tonnes per year in average for this period, while re-exports are neglectible<sup>289</sup>. For the period 2012-2016, Russia is by far the most important supplier of vanadium oxides to the EU, taking on average 68%, or 4,112 tonnes per year, of the import share to the EU. China and South Africa follow with 815 tonnes per year (14%) and 670 tonnes per year (11%), respectively. The world's main producer of vanadium oxides, China, seems to direct its extractions primarily to other destination outside the EU or use the commodity themselves.

About 80% of the vanadium produced is used as ferrovanadium or as a HSLA<sup>290</sup> additive. Mixed with aluminium in titanium alloys, vanadium is used in jet engines and high speed air-frames, and in terms of tool steel alloys it is used in axles, crankshafts, gears and other critical components. Vanadium alloys are also used in nuclear reactors because vanadium has low neutron-adsorption abilities and it does not deform in creeping under high temperatures (Lenntech, 2016). Vanadium oxide ( $V_2O_5$ ) is used as a catalyst in manufacturing sulfuric acid and maleic anhydride, and in making ceramics. It is added to glass to produce green or blue tint. Glass coated with vanadium dioxide ( $VO_2$ ) can block infrared radiation at some specific temperature (Lenntech, 2016).  $V_2O_3$  is used as feedstock for ferrovanadium production due to lower aluminium consumption.

The world resources of vanadium exceed 63,000,000 tonnes (USGS, 2019). Because vanadium is typically recovered as a by-product or co-product, demonstrated world resources of the element are not fully indicative of available supplies. For the EU, the European Minerals Yearbook provides vanadium resources data only for Sweden. Resources in Sweden are estimated to 24,600,000 tonnes (historic resource estimates, 0.43% vanadium), or 140,000,000 tonnes (JORC inferred resources, 0.2% vanadium), respectively (Minerals4EU, 2019). The world known reserves of vanadium are about 20,000,000 tonnes (USGS, 2019). Almost half of these reserves are located in China, and a quarter in Russia. Other important reserves are found in Australia

---

<sup>288</sup> Processed vanadium can have different forms, while the most important form are vanadium oxides. The most common way of reporting is  $V_2O_5$ .

<sup>289</sup> EU trade is analysed using product group codes. It is possible that materials are part of product groups also containing other materials and/or being subject to re-export, the "Rotterdam-effect". This effect means that materials can originate from a country that is merely trading instead of producing the particular material.

<sup>290</sup> high-strength low-alloy steel

and South Africa. Minor vanadium reserves are reported in Norway, Finland, Sweden, and Ukraine.

During the years 2012-2016, the world annual production of vanadium in ores and concentrates was estimated at 61,400 tonnes in average, which is concentrated in only three countries: China, Russia, and South Africa, making up 96% of the global market (WMD, 2019). Further reported producers of vanadium ores and concentrates in this period were Brazil, Kazakhstan, the United States and Australia. Brazil is indeed a new player as it started extraction only in 2014 (WMD, 2019). Global production of vanadium oxides and hydroxides (vanadium compounds) amounted to 86,300 tonnes per year in average between 2012 and 2016 (TTP Squared, 2019).

The recycling of vanadium is generally very low. Two main kinds of secondary vanadium scrap can be discerned: steel scrap, which was recycled along with the vanadium content, and spent chemical process catalysts. Also certain vanadium-bearing tools can be recycled. The total share of world production of vanadium from secondary sources has increased in the period from 2004 to 2010 and was estimated in 2011 to around 44%. It is important to note that this includes vanadium supply from alloy recycling. Without the consideration of alloy recycling, secondary sources would cover about 15% of the required vanadium input (SWEREA, 2016). There is some economic activity in the EU specialized in vanadium recycling. The end-of-life recycling input rate (EoL-RIR) was determined by the Material Substance Analysis on vanadium to 2% (European Commission, 2019).

## 28.2 Market analysis, trade and prices

### 28.2.1 Global market analysis and outlook

Future supply from South Africa has been influenced by the recent closure of Evraz Highveld mine (Evraz Highveld, 2016). Future demand seems to be influenced by innovations in the manufacturing of battery products. Roskill's vanadium report includes a focused chapter dedicated to the use cases, competing technologies, advantages, disadvantages and economics of vanadium redox batteries. To 2026, it is expected the market for stationary energy storage to increase (Roskill, 2016). Application of vanadium in the vanadium redox battery (close to 2,000 tonnes of vanadium world demand in 2016) is rapidly growing. Some analysts predict demand for vanadium in this battery for mass storage of energy (solar, wind) could increase to over 10,000 tonnes annually until 2025 (SWEREA, 2016).

Demand for vanadium in the EU is projected to increase in all sectors (steel, titanium, chemicals and energy storage), especially driven by increased steel production, compounded by an increasing unit consumption of vanadium per ton of steel (SWEREA, 2016).

**Table 213: Qualitative forecast of supply and demand of vanadium**

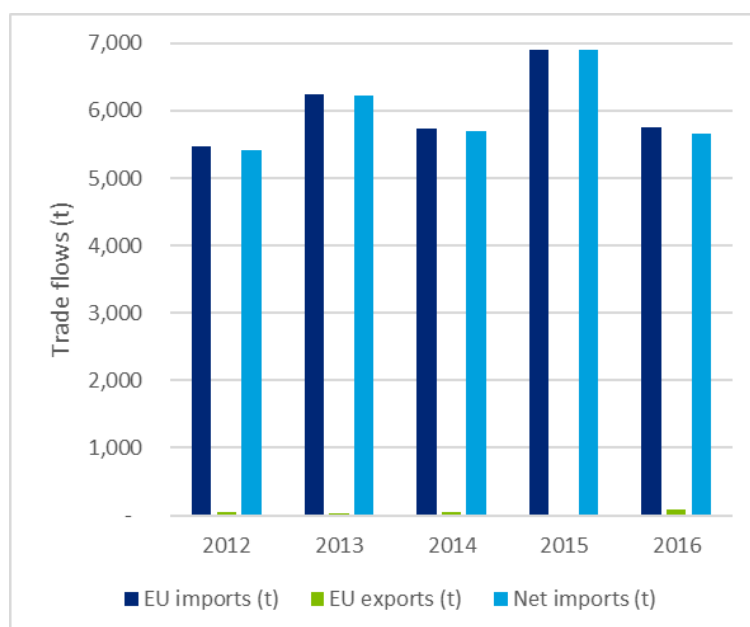
Materials	Criticality of the material in 2020		Demand forecast			Supply forecast		
	Yes	No	5 years	10 years	20 years	5 years	10 years	20 years
Vanadium	X		+	+	+	+	+	+

Since 2016, there were plans that the Mustavaara Kaivos Clean Slag project, Finland, could significantly increase EU vanadium supply<sup>291</sup>, and thus reduce the EU's dependence on vanadium imports (SWEREA, 2016). However, this project went into liquidation in early 2019 (GTK, 2019).

### 28.2.2 EU trade

There are no EU imports and exports reported at the extraction stage. At the extraction stage, the code applicable is CN 2615 90 90 "Vanadium ores and concentrates", however there is no data available at Comext. Based on the consultation of the validation workshop, it is considered, that there are no imports<sup>292</sup> at mine stage to the EU, and exports from the EU, respectively.

At the processed stage, trade in vanadium was analysed for "vanadium oxides and hydroxides" (CN 2825 30 00)<sup>293</sup>, in the form of vanadium oxide ( $V_2O_5$ ). Russia is the most important supplier of vanadium oxides to the EU, taking 68% of the import share. China and South Africa follow with 14% and 11%, respectively. The world's main producer of vanadium oxides, China, seems to direct its production predominantly to other destination outside the EU, or use the commodity itself.

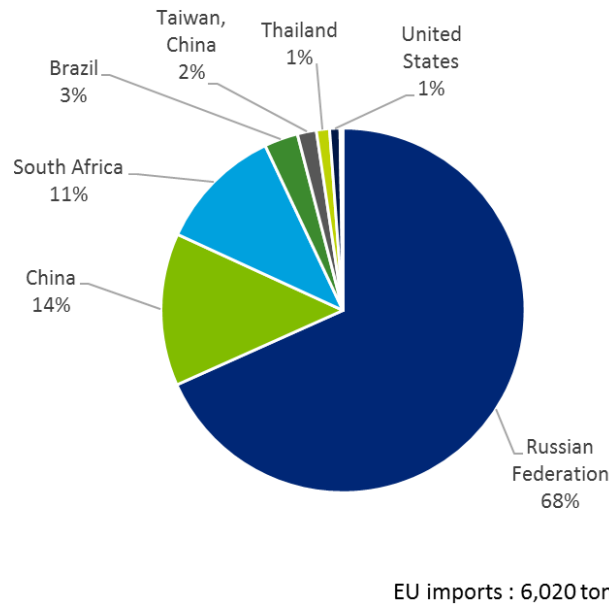


**Figure 502: EU trade flows for vanadium oxides and hydroxides, 2012-2016 (Eurostat, 2019)**

<sup>291</sup> The expected production amounted to around 5 ktonnes per year of FeV80.

<sup>292</sup> At UN Comtrade, there is no code specific to vanadium (but only mixed with niobium, tantalum, and zirconium) thus there is no way for confirmation with Comtrade data.

<sup>293</sup> EU trade is analysed using product group codes. It is possible that materials are part of product groups also containing other materials and/or being subject to re-export, the "Rotterdam-effect". This effect means that materials can originate from a country that is merely trading instead of producing the particular material.



**Figure 503: EU imports of vanadium oxides, average 2012-2016 (Eurostat, 2019; Brown *et al.*, 2018)**

At extraction stage, export tax and other trade measures have been checked for code CN 2615 90 90, at processing stage for code CN 2825 30 00 (OECD, 2019). For vanadium ores and concentrates (essentially nickel, tantalum and vanadium), an export tax of 30% is reported for China, and one of 2-5% for Burundi (since 2015). For Brazil, a temporary export quota was in force in the amount of 250 tonnes (2012-2013) and 300 tonnes (2014-2015), respectively. Fiscal taxes on exports are reported for Rwanda (4%, since 2013), and for Burundi (FBU 15,000). However, the EU did not import vanadium ores and concentrates during the period 2012-2016. (OECD, 2019)

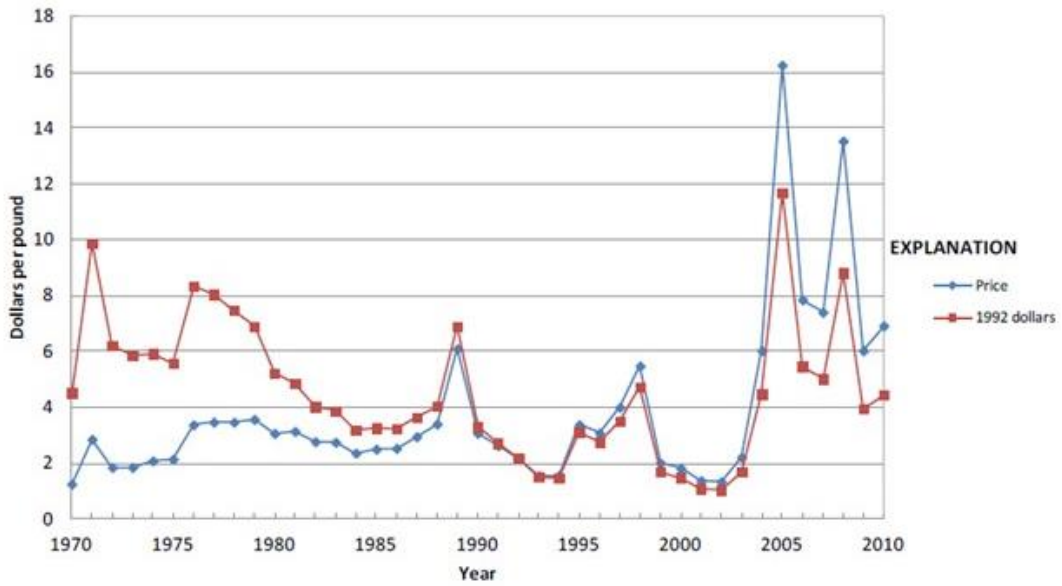
China, showing an import share of 14% (Eurostat, 2019), is the only country reported to tax vanadium oxides and hydroxides (processed stage), at an export tax rate of 5%. The export tax was already introduced in 2009 and still in force in 2017 (OECD, 2019).

### 28.2.3 Prices and price volatility

Ferrovandium is traded at the open market, e.g. the global B2B trade platform FerroAlloyNet<sup>294</sup>. Vanadium is associated with two main prices, usually traded in US dollars: one is for the ferroalloy ferrovandium, and the other for vanadium pentoxide, of which much of the world's ferrovandium is made of. Both ferrovandium (70-80%) and vanadium pentoxide have been common forms for trading vanadium. Prices for vanadium ore and vanadium metal are not published.

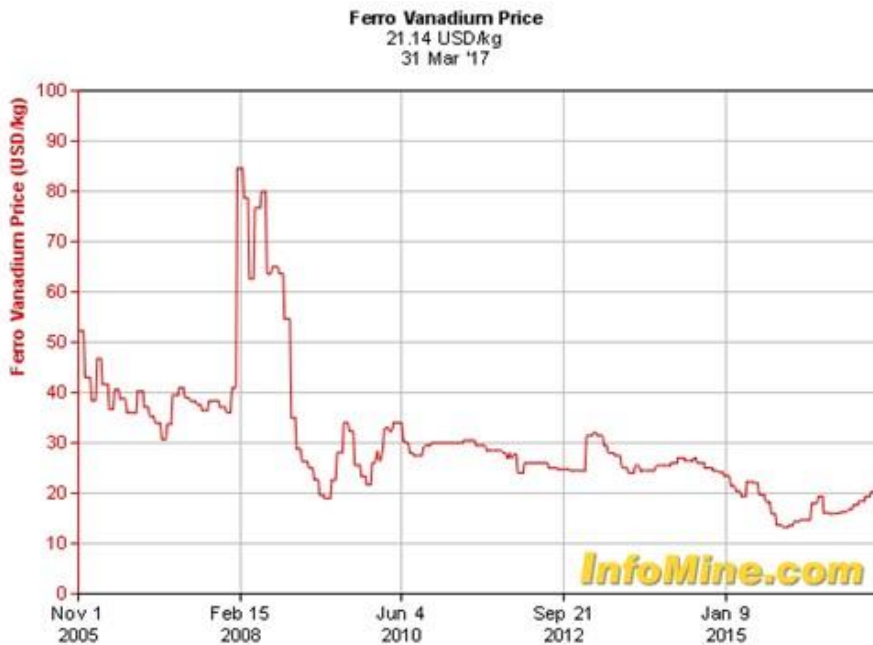
Vanadium pentoxide has not been traded on the free market, but rather was a producer price, to that effect it showed a low volatility.

<sup>294</sup> <http://www.ferroalloynet.com/>



**Figure 504: Price development of vanadium pentoxide, 1970-2010 (USGS, 2013)**

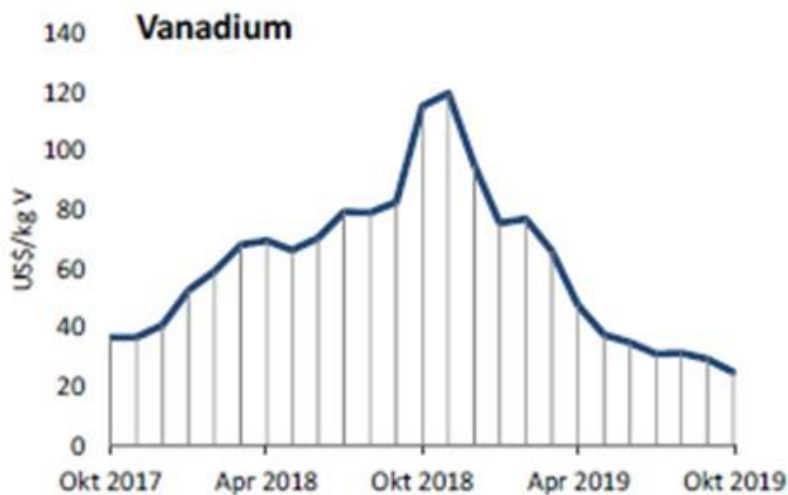
The prices of vanadium are reported to be influenced by production process management costs, rather than by markets and trade developments. Since 2000 vanadium is one of the materials that have witnessed the greatest price volatility (European Commission, 2017), in spite of relative stable demand levels (55,000-65,000 tonnes per year) in this period. Also recently, in the period May 2018 to April 2019, the volatility of vanadium has the highest volatility (60%) of all materials monitored by DERA, with an upward trend (DERA, 2019b).



**Figure 505: Price development of ferrovanadium, November 2005 to April 2017 (Infomine, 2017)**



The average price of ferrovanadium<sup>295</sup> between 2011 and 2015 was US\$25.11 per kilogram (DERA, 2016). For the period November 2018 to October 2019, average prices of US\$56.0 per kilogram have been reported for ferrovanadium<sup>296</sup> (DERA, 2019a); the price development for October 2017 to October 2019 is shown in Figure 506.



**Figure 506: Price development of ferrovanadium, October 2017 to October 2019 (DERA, 2019a)**

As vanadium is used to a large degree in the various steel sectors, steel demand has a strong influence on the vanadium supply and price. Given the close relationship between the vanadium and steel markets, the outlook for steel production has a large bearing on the outlook for the vanadium market. (USGS, 2013)

The long-term prices of vanadium oxide (V<sub>2</sub>O<sub>5</sub>) are shown in

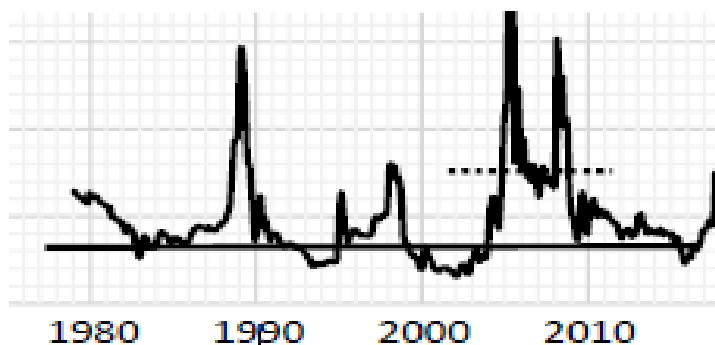
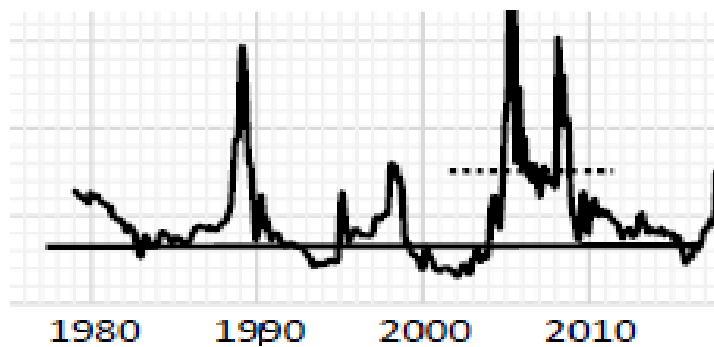


Figure 507. The price curve shows real prices.

<sup>295</sup> containing 78% of vanadium

<sup>296</sup> 70-80% vanadium, cif Europe



**Figure 507: Vanadium oxide prices in US\$ per tonne. Vertical dashed line indicate breaks in price specification.(Buchholz *et al.*, 2019)**

## 28.3 EU demand

The world global market of vanadium in ores is about 62,000 tonnes in 2016 (WMD, 2019). Annual worldwide production of processed vanadium (vanadium oxides and hydroxides) is 77,000 tonnes in 2016. Vanadium is a strategic metal for Europe's industries, which used about 13% of worldwide production (11,000 tonnes in 2013) (BRGM, 2017).

### 28.3.1 EU demand and consumption

The apparent EU consumption<sup>297</sup> (production+imports-exports) of vanadium oxides is around 12,700 tonnes. The amount of vanadium being traded in the form of oxides through the EU as re-exports is around 43 tonnes.

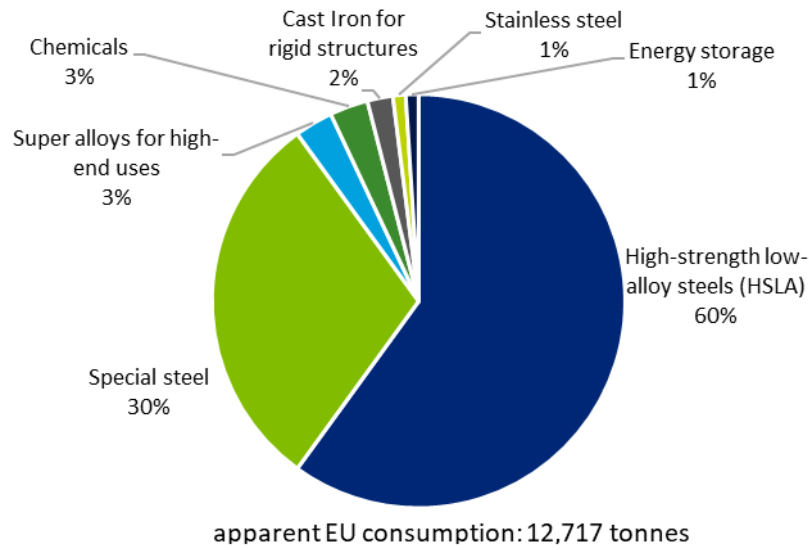
### 28.3.2 Uses and end-uses of Vanadium in the EU

Vanadium is mainly used for the production of high-strength low-alloy (HSLA) steels, special steels, special alloys and catalysts. The global end-uses of vanadium are shown in Figure 508.

Vanadium is an important alloying element in HSLA steels, tool steels and certain types of other steels. The formation of vanadium-rich carbides and nitrides gives strength to steel, even when a few kilograms of vanadium per ton of steel is added. Furthermore, vanadium also inhibits corrosion and oxidation of the steels. In fact, most of the vanadium produced (about 80%) is used as ferrovanadium or as a HSLA additive.

Vanadium, when combined with titanium, produces a stronger and more stable alloy, and when combined with aluminium in titanium alloys, it produces a material suitable for jet engines and high-speed airframes, while tool steel alloys are used in axles, crankshafts, gears and other critical components. Vanadium alloys are also used in nuclear reactors because vanadium has low neutron-adsorption abilities and it does not deform in creeping under high temperatures (Lenntech, 2016).

<sup>297</sup> apparent EU consumption = domestic production + imports - exports



**Figure 508: EU end uses of vanadium, average 2012-2016 (Atlantic, 2016)**

Vanadium-bearing catalysts are used in hydrocarbon processing to remove nickel and vanadium from the process stream.

Vanadium compounds, in particular vanadium oxide ( $V_2O_5$ ), is used as a catalyst in manufacturing sulfuric acid and maleic anhydride and in making ceramics. It is added to glass to produce green or blue tint. Glass coated with vanadium dioxide ( $VO_2$ ) can block infrared radiation at some specific temperature (Lenntech, 2016).  $V_2O_3$  is used as feedstock for ferrovandium production due to lower aluminium consumption. Figure 508 presents the main uses of vanadium in the EU.

Relevant industry sectors are described using the NACE sector codes (Eurostat, 2016c).

The calculation of economic importance is based on the use of the NACE 2-digit codes and the value added at factor cost for the identified sectors (Table 214). The value added data correspond to 2013 figures.

**Table 214: Vanadium applications, 2-digit NACE sectors, associated 4-digit NACE sectors, and value added per sector (Eurostat, 2019)**

<b>Applications</b>	<b>2-digit NACE sector</b>	<b>4-digit NACE sector</b>	<b>Value added of sector (M€)</b>
High-strength low-alloy steels	C24 - Manufacture of basic metals	24.45 Other non-ferrous metal production	55,426
Special steel	C25 - Manufacture of fabricated metal products, except machinery and equipment	25.29 Manufacture of other tanks, reservoirs and containers of metal	148,351
Super alloys for high-end uses	C29 - Manufacture of motor vehicles, trailers and semi-trailers	29.20 Manufacture of bodies (coachwork) for motor vehicles; manufacture of trailers	160,603
Chemicals	C20 - Manufacture of chemicals and chemical products	20.12 Manufacture of dyes and pigments	105,514
Cast iron for rigid structures	C30 - Manufacture of other transport equipment	29.20 Manufacture of bodies (coachwork) for motor vehicles; manufacture of trailers	44,304
Stainless steel	C28 - Manufacture of machinery and equipment n.e.c.	28.11 Manufacture of engines and turbines	182,589
Energy storage	C27 - Manufacture of electrical equipment		80,745

- **Steel (HSLA – high-strength low-alloy):** The key demand driver at the current time is a move to lighter weight and higher strength steels. The addition of just 0.2% vanadium to steel increases steel strength by up to 100% and reduces weight in relevant applications by up to 30% (Infomine, 2016). Vanadium itself is soft in its pure form, but when it is alloyed with other metals such as iron, it hardens and strengthens them significantly. Consequently, vanadium is used extensively to make alloys (mostly steel alloys) for tools and construction purposes. Most of the vanadium consumed is used for these applications.
- **Steel (Carbon):** Vanadium is also alloyed with iron to make carbon steel, next to the HSLA mentioned above. These hard, strong ferro-vanadium alloys are used for military vehicles and other protective vehicles. It is also used to make car engine parts that must be very strong, such as piston rods and crank shafts.
- **Chemical applications:** Some vanadium is used in other industrial applications. For example, vanadium pentoxide (V<sub>2</sub>O<sub>5</sub>) is used production of glass and ceramics and as a chemical catalyst.

- **Batteries:** The vanadium redox battery (VRB)<sup>298</sup> is a type of rechargeable flow battery that employs vanadium ions in different oxidation states to store chemical potential energy (Knight, 2014). The use of vanadium in vanadium redox batteries started in the 1980s. Due to their relative bulkiness (amongst others), most vanadium batteries are currently used for grid energy storage, i.e., attached to power plants or electrical grids.

### 28.3.3 Substitution

The substitution of vanadium in all types of steels is basically possible. However, the substitution is limited to only a few degrees by certain elements, such as columbium/niobium, due to poorer performance of common substitutes in the steels. Steels containing vanadium as an alloying component can be replaced by steels containing various combinations of other alloying elements (manganese, molybdenum, niobium, titanium, and tungsten to some extent) (USGS, 2019). However, niobium can only partially substitute vanadium in tool steels, as niobium can hardly contribute to the secondary hardness of tool steels during the heat treatment. A study done on niobium for vanadium substitution in steel making concluded that 46% of vanadium used in steel could potentially be substituted by niobium (Korchynsky, 2004). Replacement of vanadium with other elements requires significant technical adjustments of the steel production process to ensure the product specifications and at the same time to ensure that the quality of the steels is not compromised. Therefore, substitution for vanadium is normally not considered for short-term changes in market conditions because of the considerable effort involved in implementing the change (European Commission, 2017b; USGS, 2017b; USGS, 2017c; Wilmes & Zwick, 2002).

The above substitution options are available for all major uses of ferrovanadium, in tubes and pipes, turbines, automotive parts and building materials. Ferrovanadium used as noble alloy for special steel (FeV80, FeV50) can be substituted partially by ferroniobium. Key factors determining the degree of substitution are the relative price difference between the two FeV and FeNb, as well as the availability of niobium.

In special alloys, vanadium is irreplaceable. Currently, there is no acceptable substitute for vanadium in aerospace applications as vanadium-titanium alloys have the best strength-to-weight ratio of any engineered materials (USGS, 2017c; USGS, 2019).

In catalysts, vanadium can be replaced in some cases by other elements, such as nickel and platinum in several chemical processes (USGS, 2019).

In paints and varnishes, which is a specific part of the chemical applications of vanadium, titanium is a substitute for vanadium use.

Batteries using vanadium are serving a growing market, that has to be assumed can also be served by batteries containing more conventional materials from the alkaline group.

---

<sup>298</sup> also known as the vanadium flow battery (VFB) or vanadium redox flow battery (VRFB)

## 28.4 Supply

---

### 28.4.1 EU supply chain

There have been around ten major mine corporations engaged in vanadium extraction and refinery, located in the United States, Australia, China, Canada, South Africa, but also in Austria, Germany, and the Czech Republic (European Commission, 2017). Global extraction of vanadium is concentrated in China, Russia and South Africa, making up together 96% of global production. There is no extraction of vanadium in the EU, as well as no imports or exports of vanadium ores and concentrates.

In the EU, Austria (6,630 tonnes, 98%) and Germany (110 tonnes, 2%) produce vanadium oxides. The import reliance of the EU on vanadium oxides is calculated as 47%.

The base metal production in Europe is relatively less specialized in the use of vanadium. Annually, about 2,000 tonnes of ferrovanadium are produced in the Czech Republic (BGS, 2015). There is some economic activity in the EU specialized in vanadium recycling.

China is the only nation to tax vanadium oxides, at a tax rate of 5%. China also taxed vanadium ores and concentrates (essentially nickel, tantalum and vanadium), at a tax rate of 30% (in 2014, only), the Democratic Republic of Congo applies 10% tax, Rwanda shows a fiscal tax of 4% (OECD, 2016). Brazil applied an export quota of 300 tonnes per year. The Democratic Republic of Congo has a licensing requirement. There are a limited number of trade restrictions being applied to vanadium metal: Morocco, Vietnam and Argentina have a tax on vanadium, whereas China applies an export quota of 231 tonnes (OECD, 2016).

### 28.4.2 Supply from primary materials

#### 28.4.2.1 Geology, resources and reserves of vanadium

**Geological occurrence:** The presence of vanadium in the earth's crust is moderate, with 97 ppm<sup>299</sup> upper crustal abundance (Rudnick & Gao, 2003); in seawater it is estimated to be about 0.0014 ppm. Among 65 minerals that contain vanadium, the most common vanadium minerals include magnetite (Fe<sub>3</sub>O<sub>4</sub>), patronite (VS<sub>4</sub>), vanadinite [Pb<sub>5</sub>(VO<sub>4</sub>)<sub>3</sub>Cl], and carnotite [K<sub>2</sub>(UO<sub>2</sub>)<sub>2</sub>(VO<sub>4</sub>)<sub>2</sub> · 3H<sub>2</sub>O]. Vanadium is also present in phosphate, bauxite and iron ores. Moreover, it is present in fossil fuel deposits such as oil and coal. The main host mineral of oxidic vanadium ores is vanadium-bearing magnetite, commonly found in gabbro ore bodies. Typical vanadium grades are 0.7-1.5%.

**Global resources and reserves<sup>300</sup>:** Vanadium is found in certain iron ores, from which it can be extracted (BRGM, 2017). The world resources of vanadium exceed 63,000,000 tonnes (USGS, 2019). Because vanadium is typically recovered as a by-product or co-product, for example from

---

<sup>299</sup> parts per million

<sup>300</sup> There is no single source of comprehensive evaluations for resources and reserves that apply the same criteria to deposits of vanadium in different geographic areas of the EU or globally. The USGS collects information about the quantity and quality of mineral resources but does not directly measure reserves, and companies or governments do not directly report reserves to the USGS. Individual companies may publish regular mineral resource and reserve reports, but reporting is done using a variety of systems of reporting depending on the location of their operation, their corporate identity and stock market requirements. Translations between national reporting codes are possible by application of the CRIRSCO template.<sup>300</sup>, which is also consistent with the United Nations Framework Classification (UNFC) system. However, reserve and resource data are changing continuously as exploration and mining proceed and are thus influenced by market conditions and should be followed continuously.

iron ores, demonstrated world resources of the element are not fully indicative of available supplies.

The world known reserves of vanadium (material content) are about 20,000,000 tonnes (USGS, 2019). Almost half of these reserves are located in China, and a quarter in Russia. Other important reserves are found in Australia and South Africa (Table 215).

**Table 215: Estimated global reserves of vanadium in 2019 (USGS, 2019; GTK, 2012)**

<b>Country</b>	<b>Estimated Vanadium Reserves (tonnes)</b>
China	9,500,000
Russia	5,000,000
South Africa	3,500,000
Australia**	2,100,000
Brazil	130,000
USA	45,000
Norway*	55,000
Finland*	25,000
Sweden*	15,000
Others	N/A
<b>World total (rounded)</b>	<b>20,000,000</b>

\* Data from (USGS, 2015). \*\* For Australia, Joint Ore Reserves Committee-compliant reserves were about 1.3 million tons.

Compared to 2017, novel estimates for Brazil reserves were provided, and Chinese reserves increased by 500,000 tonnes based on government reports. Also the Australian reserves were increased by 300,000 tonnes. In summary, the reserves thus increased from by 1,000,000 tonnes in 2017 to 20,000,000 tonnes in 2019.

**EU resources and reserves**<sup>301</sup>: For the EU, the European Minerals Yearbook provides vanadium resources data only for Sweden (Table 216). Historic estimates amount to 24,600,000 tonnes (0.43% vanadium), while inferred resources amount to 140,000,000 tonnes (JORC, 0.2% vanadium) . These cannot be summed as they do not use the same reporting code.

---

<sup>301</sup> For Europe, there is no complete and harmonised dataset that presents total EU resource and reserve estimates for vanadium. The Minerals4EU project is the only EU-level repository of some mineral resource and reserve data for vanadium, but this information does not provide a complete picture for Europe. It includes estimates based on a variety of reporting codes used by different countries, and different types of non-comparable datasets (e.g. historic estimates, inferred reserves figures only, etc.). In addition, translations of Minerals4EU data by application of the CRIRSCO template is not always possible, meaning that not all resource and reserve data for vanadium the national/regional level is consistent with the United Nations Framework Classification (UNFC) system (Minerals4EU 2019). Many documented resources in Europe are based on historic estimates and are of little current economic interest. Data for these may not always be presentable in accordance with the UNFC system. However a very solid estimation can be done by experts.

**Table 216: Resource data for Europe compiled in the European Minerals Yearbook (Minerals4EU, 2019)**

Country	Reporting code	Quantity	Unit	Grade	Code Resource Type
Finland	JORC	62.15	Mt	0.13 % V	
	JORC	6.55	Mt	0.12 % V	
Sweden	Historic code	24.6	Mt	0.43 % V	Historic resource estimates
	JORC	140	Mt	0.2 % V	inferred

In the SCREEN project, further information is provided on vanadium resources in Finland, Bulgaria, Estonia, Greenland, Norway, Poland, Sweden and the United Kingdom (Lauri *et al.*, 2018).

In Europe, vanadium reserves are reported in Norway, Finland, Sweden, and Ukraine, but together they make up less than 1% of the global reserves (USGS, 2019; GTK, 2012; Minerals4EU, 2019). The European Mineral Yearbook does not report reserves for the EU member states, but provides reserves data only for Ukraine, with 15,500 tonnes of V<sub>2</sub>O<sub>5</sub> contained in vanadium ores (Table 217).

**Table 217: Reserve data for Europe compiled in the European Minerals Yearbook (Minerals4EU, 2019)**

Country	Reporting code	Value	Unit	Grade	Code Reserve Type
Finland	JORC	99,000,000	t	unknown. ilmenomagnetite	
	JORC	62,150,000	t	0.13 % vanadium	
	JORC	6,550,000	t	0.12 % vanadium	
Ukraine	Russian Classification	-/-/3,493,000	t	n/a / n/a / n/a vanadium ore	A/B/C1
		-/-/15,500	t	n/a / n/a / n/a vanadium ore, V <sub>2</sub> O <sub>5</sub> contained	A/B/C1

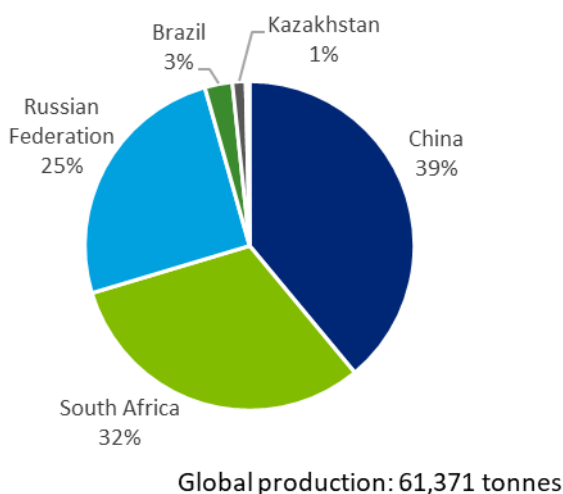
#### 28.4.2.2 World mine production

Global mine production of vanadium from vanadium ores and concentrates between 2012 and 2016 amounted to about 61,400 tonnes per year in average. The main producers of vanadium ores are China, South Africa, Russia, Brazil, and Kazakhstan, United States, and Australia. Brazil is a new player on the vanadium market as it started the extraction only in 2014 (WMD, 2019).

Although Europe has some vanadium resources, these are mainly deposits of titanium-bearing iron ore containing about 1% of vanadium, or steel slag containing up to 3%. Mining these resources is not economically viable (BRGM, 2017). There is no production of vanadium ores and concentrates in the EU (Brown *et al.*, 2018).



The global mine production of vanadium is shown in Figure 509.



**Figure 509: Global mine production of vanadium in tonnes, average 2012–2016 (WMD, 2019)**

### **28.4.3 Supply from secondary materials/recycling**

The recycling of vanadium is generally very low. Two main kinds of secondary vanadium scrap can be discerned: steel scrap, which was recycled along with the vanadium content, and spent chemical process catalysts. Also certain vanadium-bearing tools can be recycled.

The total share of world production of vanadium from secondary sources has increased in the period 2004-2010 and is now believed to be still at around 44%. Important to note is that this includes vanadium supply from alloy recycling. Without the consideration of alloy recycling, secondary sources would cover 15% of the required vanadium input (SWEREA, 2016). There is some economic activity in the EU specialized in vanadium recycling.

#### **28.4.3.1 Post-consumer recycling (old scrap)**

End-of-life vanadium recycling takes place by the recycling of vanadium-containing steel scraps. The scrap is collected and segregated by material specification. Typical post-consumer recycling comprise spent catalysts, which are collected and then treated in induction furnace operations. The EoL-RIR of vanadium in the EU for the period 2012-2016 is 2% (Table 218) (European Commission, 2019).

USGS reports that the end-of-life recycling rate is 44% for the United States (Goonan, 2011).

**Table 218: Material flows relevant to the EoL-RIR of Vanadium, average 2012-2016 (European Commission, 2019)**

MSA Flow	Value (t)
B.1.1 Production of primary material as main product in EU sent to processing in EU	0
B.1.2 Production of primary material as by product in EU sent to processing in EU	640
C.1.3 Imports to EU of primary material	6,962
C.1.4 Imports to EU of secondary material	0
D.1.3 Imports to EU of processed material	9,236
E.1.6 Products at end of life in EU collected for treatment	7,425
F.1.1 Exports from EU of manufactured products at end-of-life	1,602
F.1.2 Imports to EU of manufactured products at end-of-life	16
G.1.1 Production of secondary material from post consumer functional recycling in EU sent to processing in EU	292
G.1.2 Production of secondary material from post consumer functional recycling in EU sent to manufacture in EU	0

### 28.4.3.2 Industrial recycling (new scrap)

The collection and handling of vanadium-containing metal scrap are fairly straightforward. Scrap is generated during semi-fabrication and manufacturing operations and consists of items such as clippings, stampings, and turnings. These are usually segregated by material specification and returned to controlled-atmosphere induction furnace operations, where the scrap is matched and melted into a product having the desired chemistry (Wernick & Themelis, 1998). Co-producers (via vanadium slag) and primary producers generally are the lowest cost producers. Those recovering vanadium from fly-ash, uranium and hard coal mining incur the highest cost. This is the reason that the share of secondary sources for vanadium production has dropped in the last years (Lindvall, 2015).

Entry barriers for new producers are high, with long development time required to master technology, large capital exposure and market risks.

Secondary vanadium can also be obtained from fossil fuel processing, including mineral oils. Vanadium is present in crude oil from the Caribbean basin, parts of the Middle East and Russia, as well as in tar sands in western Canada. Coal in parts of China and USA contains vanadium as well. During the refining or burning of these energy sources, a vanadium bearing ash, slag, spent catalyst or residue is generated which can be processed for vanadium recovery (Lindvall, 2015).

Such catalysts are as well required for the processing of uranium-vanadium ores, bauxite, phosphate rock and lead vanadates, that can contain vanadium. The material recovered (residue) is processed for the metal content, and the spent catalysts are recycled (Goonan, 2011). Vanadium recycled from spent chemical process catalysts is significant and may comprise as much as 40% of the total supply.

A new technology for the extraction of vanadium from vanadium-bearing iron ores in combination with secondary resources of vanadium is currently under development. The project EXTRAVAN<sup>302</sup> aims for improving the economic viability of the joint exploitation of primary and

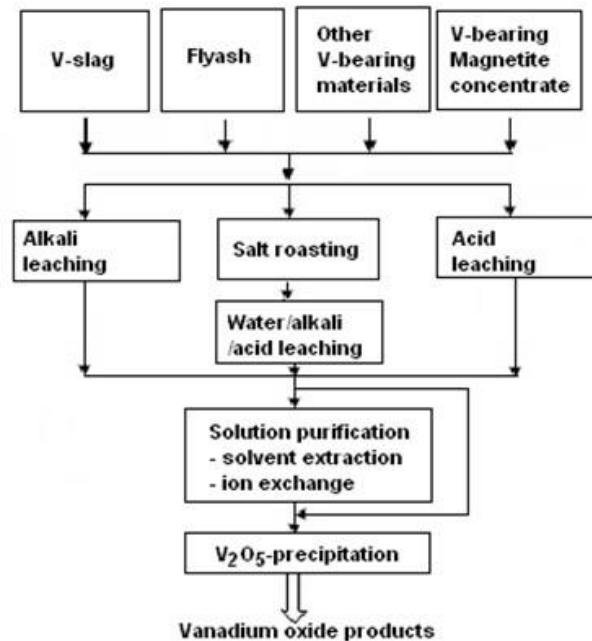
<sup>302</sup> The project "Innovative extraction and management of vanadium from high vanadium iron concentrate and steel slags" (EXTRAVAN) developed innovative technologies for cost-efficient vanadium extraction limiting associated impacts on the environment; it is funded under the European ERA-MIN2 programme for sustainable production of raw materials in Europe (BRGM, 2017). The EXTRAVAN consortium consists of Swerea MEFOS (coordinator), the French Geological Survey (BRGM), the Geological Survey of Finland (GTK), KTH and Mustavaaran Kaivos Oy (SWEREA, 2014).

secondary resources, including the separation of materials undesired in this process like phosphorus.

#### 28.4.4 Processing of Vanadium

Vanadium, as primary material, is mainly produced as co-product from vanadium slag before the steel convertor. The processing of vanadium slag is a hot metal pre-treatment, resulting in vanadium products. For this reason, vanadium is assessed at the refining stage as vanadium oxides ( $V_2O_5$  and  $V_2O_3$ ). Figure 510 shows the sources and the most common production routes.

The vanadium slag process can be described as follows. Vanadium-titanomagnetite ores globally constitute the main source for production of vanadium containing commodities, most importantly vanadium pentoxide ( $V_2O_5$ ) and ferrovanadium (FeV). FeV is produced from vanadium trioxide ( $V_2O_3$ ) or vanadium pentoxide ( $V_2O_5$ ). Extraction of vanadium as co-product to iron is usually done by concentrating the vanadium into a vanadium-slag. Production of vanadium-slag involves two main pyro-metallurgical steps. At first, the ore concentrate or DRI (Direct Reduced Iron) is reduced to a hot metal with a vanadium content of 0.4-1.3 wt%. In the second step, the vanadium in the hot metal is oxidized to the vanadium slag at around 1400 °C. The vanadium slag is an acid FeO-SiO<sub>2</sub> based slag with normally 9-15 wt% of vanadium. The vanadium slag is then converted to vanadium pentoxide ( $V_2O_5$ ) by a salt roast and leach process. Vanadium slag is oxidized by oxygen and transformed into water soluble sodium vanadates in the presence of sodium salts ( $Na_2CO_3$ , NaCl, NaOH and/or  $Na_2SO_4$ ). Thereafter,  $V_2O_3$  or  $V_2O_5$  is obtained from the leachate by precipitation and calcination (Lindvall *et al.*, 2016).



**Figure 510: Production routes of vanadium**

About 30% of the primary vanadium produced is from direct leaching of vanadium ores. Titanomagnetite is by far the most important mineral, a by-product mainly from vanadium slags, although other sources are available.(SWEREA, 2016)

Other sources of primary vanadium are mineral oils, uranium-vanadium ores, bauxite, phosphate rock and lead vanadates can contain vanadium, although vanadium from these sources is sometimes considered secondary material.

The average global production of vanadium oxides and hydroxides for the period 2012-2016 was about 86,300 tonnes (Vanitec, 2019). This production figure includes all vanadium oxides produced, vanadium in other chemical compounds as well as ferrovandium that have not been produced via oxide routes. There is no vanadium pentoxide (V<sub>2</sub>O<sub>5</sub>) production in the EU, opposed to ferrovandium (FeV).

## 28.5 Other considerations

### 28.5.1 Environmental and health and safety issues

It has been estimated that around 65,000 tonnes per year of vanadium enter the environment from natural sources (crustal weathering and volcanic emissions) and around 200,000 tonnes per year as a result of man's activities. The major anthropogenic point sources of atmospheric emission are metallurgical works (30 kilogram per tonne of vanadium produced), followed by the burning of crude or residual oil and coal (0.2-2 kilogram per 1,000 tonnes and 30-300 kilogram per 106 litres, respectively). Global vanadium emissions into the atmosphere from coal combustion in 1968 were estimated to 1,730-3,760 tonnes. The contribution of vanadium to the atmosphere from residual-fuel combustion was estimated at 12,400-19,000 tonnes in 1969 and 14,000-22,000 tonnes in 1970. In the production of ferrovandium for alloy additions in steel-making, vanadium emission to the atmosphere was estimated at 144 tonnes in 1968. The burning of wood, other vegetable matter and solid wastes probably does not result in significant vanadium emission. In 1972, about 94% of all anthropogenic emissions of vanadium to the atmosphere in Canada (2,065 tonnes) resulted from the combustion of fuel oil and only 1.2% from metallurgical industries (WHO, 2000).

EU occupational safety and health (OSH) requirements exist to protect workers' health and safety. Employers need to identify which hazardous substances they use at the workplace, carry out a risk assessment and introduce appropriate, proportionate and effective risk management measures to eliminate or control exposure, to consult with the workers who should receive training and, as appropriate, health surveillance<sup>303</sup>.

### 28.5.2 Socio-economic issues

No relevant socio-economic issues were reported.

## 28.6 Comparison with previous EU assessments

The results of this review and earlier assessments are shown in Table 219.

**Table 219: Economic importance and supply risk results for vanadium in the assessments of 2011, 2014, 2017 and 2020 (European Commission, 2011; European Commission, 2014; European Commission, 2017)**

Assessment	2011		2014		2017		2020	
	EI	SR	EI	SR	EI	SR	EI	SR
Vanadium	9.7	0.7	9.1	0.8	3.7	1.6	4.4	1.7

<sup>303</sup> <https://ec.europa.eu/social/main.jsp?catId=148>

After the large drop of the Economic Importance in 2017<sup>304</sup>, it rose again significantly from 3.7 to 4.4, mainly due to developments within the EU economy.

The Supply Risk increased steadily since the beginning. Until 2014 the Supply Risk was about 0.7 to 0.8, but then about doubled in both 2017<sup>305</sup> and 2020. Compared with the 2017 analysis, the 2020 analysis revised and corrected the interpretation of the underlying datasets. The assessment at the processing stage is based solely on trade data, due to missing information of vanadium oxide production. The source countries for the EU imports are strongly concentrated: Russia alone provides 68% of the imported vanadium oxides and hydroxides, and in sum 93% are provided by the top-three source countries (beside Russia also China and South Africa). In addition, the data availability implies the nonconsideration of EU production (in case existing).

## 28.7 Data sources

---

The quality of data sources of vanadium is mixed. Time series are available for trade in vanadium ores and oxides. Global production data is available for vanadium ores (WMD, 2019), while the USGS statistics on the production of vanadium oxides (USGS, 2016) is not continuously updated. Instead of the USGS Minerals Yearbook, data from the USGS Mineral Commodity Summaries could be used in future (which might differ).

For imports, the trade code applicable at the extraction stage is CN 2615 90 90 "vanadium ores and concentrates", but there is no data available. No adequate UN Comtrade trade code<sup>306</sup> is available to validate the Comext information; indeed, the shares of vanadium versus tantalum and niobium in the product group are not known (SWEREA, 2016). It is estimated and validated at the SCREEN workshop that there are no imports at the extraction stage to the EU.

At the processing stage, no global production data is available<sup>307</sup>; data from the Material System Analysis (MSA) on Vanadium (in prep.) was not used here, as Vanitec, the source used at the MSA, does not provide data on country level. Trade in vanadium in processing stage was analysed for trade code CN 2825 30 00 "Vanadium oxides and hydroxides". Data was used from Eurostat Comext (2019) for the criticality assessment. Data from UN Comtrade (code 2825 30) were used for validation purposes.

---

<sup>304</sup> The main difference from the previous two assessments is the lower score for vanadium in Economic Importance. This is, as in the case of some other alloying materials, probably due to the allocation to NACE-2 sectors rather than the "Megasectors". This approach had the base metal products and more advanced metal products assigned to megasectors with high Value Added totals such as machinery and transport equipment. The share of these end-use sectors at the end of value chains is now smaller.

<sup>305</sup> The SR result for 2017 is based on trade data for vanadium ore using both the global HHI and the EU HHI as prescribed in the revised criticality methodology. In the 2014 assessment, the major global producers were South Africa (37%), China (36%) and Russia (24%). The 2017 assessment also identifies these countries as the major global producers, however with slightly different shares: China (53%), which ranks as first producer, South Africa (25%) and Russia (20%). Contrary to the 2014 assessment, the 2017 assessment incorporates trade data on actual EU sourcing, which takes into account the EU supply to estimate the supply risk. The dependency of Russia and China for almost 85% of the EU imports explains the high supply risk result.

<sup>306</sup> At UN Comtrade, there does not exist a code specific to vanadium ores, but only mixed with niobium, tantalum and zirconium.

<sup>307</sup> The USGS Minerals Yearbook (USGS, 2016) does not cover processed vanadium, but extracted vanadium.

### **28.7.1 Data sources used in the factsheet**

Atlantic (2016). Vanadium industry. Atlantic ltd. Available at:  
<http://atlantictld.com.au/projects/windimurra/industry>

BGS (2016). World Mineral Production 2010-2014 [online]. Keyworth, Nottingham British Geological Survey, Available at: <http://www.bgs.ac.uk/mineralsuk/statistics/home.html>

BRGM (2017). EXTRAVAN: developing ecotechnologies for vanadium production in Europe. Website of the ERA-MIN2 project EXTRAVAN. 10.03.2017. Available at:  
<https://www.brgm.eu/project/extravan-developing-ecotechnologies-vanadium-production-europe>, accessed 19.11.2019

Brown, T., Gunn, G., Sievers, H., Liedtke, M., Huy, D., Homberg, D. (2018). Challenges of locating, mining and extracting CRM resources. Deliverable D3.3 of the project SCREEN, 97p., issued on 04.05.2018. Available at: <http://screen.eu/results/>, accessed 19.11.2019

Buchholz P., Wellmer F.W., Bastian D., Liedtke M. (2019) Leaning against the wind: Low price benchmarks for acting anticyclically in the metal markets. Mineral Economics.  
<https://doi.org/10.1007/s13563-019-00199-y>

DERA (2016). Pricelist of raw materials/ [online] Available at:  
[http://www.bgr.bund.de/DE/Themen/Min\\_rohstoffe/Produkte/Preisliste/cpl\\_16\\_11.pdf?\\_\\_blob=publicationFile](http://www.bgr.bund.de/DE/Themen/Min_rohstoffe/Produkte/Preisliste/cpl_16_11.pdf?__blob=publicationFile)

DERA (2019a). Preismonitor. Oktober 2019. [online] Available at: [https://www.deutsche-rohstoffagentur.de/DERA/DE/Rohstoffinformationen/Rohstoffpreise/rohstoffpreise\\_node.html](https://www.deutsche-rohstoffagentur.de/DERA/DE/Rohstoffinformationen/Rohstoffpreise/rohstoffpreise_node.html), accessed 17.11.2019

DERA (2019b). Volatilitätsmonitor. Oktober 2019. [online] Available at: [https://www.deutsche-rohstoffagentur.de/DERA/DE/Rohstoffinformationen/Rohstoffpreise/Volatilitaetsmonitor/volatilitaetsmonitor\\_node.html](https://www.deutsche-rohstoffagentur.de/DERA/DE/Rohstoffinformationen/Rohstoffpreise/Volatilitaetsmonitor/volatilitaetsmonitor_node.html), accessed 17.11.2019

European Commission (2011). Critical raw materials for the EU. [online] Available at:  
[https://ec.europa.eu/growth/sectors/raw-materials/specific-interest/critical\\_en](https://ec.europa.eu/growth/sectors/raw-materials/specific-interest/critical_en)

European Commission (2014). Report on critical raw materials for the EU – Non Critical raw materials profiles.

European Commission (2016). DG Trade. Agreements [online] Available at:  
<http://ec.europa.eu/trade/policy/countries-and-regions/agreements/>

European Commission (2017). Study on the review of the list of Critical Raw M. Critical Raw Materials Factsheets.

European Commission (2019). Draft MSA on Vanadium. Preliminary results of the Vanadium MSA Study. Internal document – not published. Reference date: 18 December 2019.

Eurostat (2016a). Statistics on the production of manufactured goods (PRODCOM NACE Rev.2). [online] Available at: <http://ec.europa.eu/eurostat/data/database>

Eurostat (2016b). Annual detailed enterprise statistics for industry (NACE Rev. 2, B-E). [online] Available at: [http://ec.europa.eu/eurostat/en/web/products-datasets/-/SBS\\_NA\\_IND\\_R2](http://ec.europa.eu/eurostat/en/web/products-datasets/-/SBS_NA_IND_R2)

Eurostat (2019). International Trade Easy Comext Database [online] Available at:  
<http://epp.eurostat.ec.europa.eu/newxtweb/>

Evraz Highveld (2016). News website. Available at: <http://www.evrazhighveld.co.za/SENS.asp>.

Goonan, T.J., (2011). Vanadium Recycling in the United States in 2004. By U.S. Geological survey, Circular 1196-S flow studies for recycling metal commodities in the US.

GTK (2012). Mineral deposits and metallogeny of Fennoscandia. Special paper 53. Geological survey of Finland. Edited by P. Eilu. Available at: [http://www.ngu.no/upload/Publikasjoner/Boker/GTK\\_sp\\_053.pdf](http://www.ngu.no/upload/Publikasjoner/Boker/GTK_sp_053.pdf)

GTK (2019). Information on the Mustavaara Kaivos Clean Slag project by the GTK's Mineral Intelligence team. Pers. comm., 25.10.2019

Gulf Chemical and Metallurgical Corporation (2009). Global production facilities. Available at: <http://www.gulfchem.com/ourFacilities.asp>.

Infomine (2016). Vanadium description. Available at: <http://www.weare121.com/blog/vanadium/>

Knight, L. (2014). Vanadium: The metal that may soon be powering your neighbourhood. Available at: <https://www.bbc.com/news/magazine-27829874>, BBC, 14.06.2014, retrieved 02.03.2015.

Lauri, L.S., Eilu, P., Brown, T., Gunn, G., Kalvig, P., Sievers, H (2018). Identification and quantification of primary CRM resources in Europe. Deliverable D3.1 of the project SCRREEN, 63p., issued on 28.02.2018. Available at: <http://screen.eu/results/>, accessed 19.11.2019

Lenntech (2016). Vanadium. Available at: <http://www.lenntech.com/periodic/elements/v.htm>

Lindvall, M. (2015). Sustainable new business opportunity for a new vanadium resource. Royal Institute of Technology (KTH) Available at: <https://www.swerea.se/en/news/new-technology-will-reduce-europes-vanadium-imports>

Lindvall, M., Berg, M., Sichen, D. (2016). The Effect of Al<sub>2</sub>O<sub>3</sub>, CaO and SiO<sub>2</sub> on the Phase Relationship in FeO-SiO<sub>2</sub> Based Slag with 20 Mass% Vanadium. Journal of sustainable metallurgy. DOI 10.1007/s40831-016-0088-y. Available at: <https://link.springer.com/article/10.1007/s40831-016-0088-y>

Minerals4EU (2019). European Minerals Yearbook. [online] Available at: [http://minerals4eu.brgm-rec.fr/m4eu-yearbook/theme\\_selection.html](http://minerals4eu.brgm-rec.fr/m4eu-yearbook/theme_selection.html), accessed 18.11.2019

Reichl, C. (2019). Information on vanadium ores. International Organizing Committee for the World Mining Congresses. pers. comm., 29.05.2019

Römp online (2016). Vanadium. Available at: <https://roempp.thieme.de/roempp4.0/do/data/RD-22-00101>

Roskill (2016). Outlook of Vanadium. Available at: <https://roskill.com/wp/wp-content/uploads/2015/06/Vanadium-2015-brochure.pdf>

Rudnick, R.L., Gao, S. (2003). Composition of the Continental Crust. In: Treatise on Geochemistry, Volume 3. Editor: Roberta L. Rudnick. Executive Editors: Heinrich D. Holland and Karl K. Turekian. pp. 659. ISBN 0-08-043751-6. Elsevier, p.1-64.

SWEREA (2014). New technology will reduce Europe's vanadium imports. Press Release by Swerea MEFOS, issued by Jan Stål, 18.12.2014.

SWEREA (2016). Expert consultation. M. Lindvall.

TTP Squared (2019). Expert consultation on global production of vanadium oxides. Pers. comm. T. Perles, TTP Squared Ltd., 31.10.2019.

USGS (2013), Metal prices in the United States through 2010: U.S. Geological Survey, Scientific Investigations Report 2012-5188, 204 p., available only at <http://pubs.usgs.gov/sir/2012/5188>

USGS (2015). Minerals Yearbook: Vanadium. By Polyak, D. E. Available at: <http://minerals.usgs.gov/minerals/pubs/commodity/vanadium/myb1-2015-vanad.pdf>

USGS (2016). Minerals Yearbook: Vanadium. By Polyak, D. E. Available at: <https://www.usgs.gov/centers/nmic/vanadium-statistics-and-information>, accessed at 19.11.2019.

USGS (2017). Mineral Commodity Summaries - Vanadium. Available at: <http://minerals.usgs.gov/minerals/pubs/commodity/vanadium/myb1-2017-vanad.pdf>

USGS (2019). Mineral Commodity Summaries - Vanadium. Available at: <http://minerals.usgs.gov/minerals/pubs/commodity/vanadium/myb1-2017-vanad.pdf>

Vanitec (2019). Production and consumption – 2011-2017 Vanadium statistics. Available at: <http://vanitec.org/vanadium/production-consumption>

Wernick, I.K., Themelis, N.J., (1998), Recycling metals for the environment: Annual Review of Energy and the Environment, v. 23, p. 465-497. Available at: <http://www.seas.columbia.edu/earth/papers/aree98.pdf>.

WHO (2000) Air quality guidelines, chapter 6.12 Vanadium. Available at: [http://www.euro.who.int/\\_data/assets/pdf\\_file/0016/123082/AQG2ndEd\\_6\\_12vanadium.PDF](http://www.euro.who.int/_data/assets/pdf_file/0016/123082/AQG2ndEd_6_12vanadium.PDF)

WMD (2018) World Mining Data 2018, Reichl, C.; Schatz, M; Zsak, G. Iron and Ferro Alloy Metals, non Ferrous Metals, Precious Metals, Industrial Minerals, Mineral Fuels. Austrian Federal Ministry of Sustainability and Tourism. [online] Available at: [www.en.bmwf.at/Energy/WorldMiningData/Seiten/default.aspx](http://www.en.bmwf.at/Energy/WorldMiningData/Seiten/default.aspx)

## **28.7.2 Data sources used in the criticality assessment**

Atlantic Ltd. (2016). Vanadium industry. Available at: <http://atlantictld.com.au/projects/windimurra/industry>

BGS (2016). World Mineral Production 2010-2014 [online]. Keyworth, Nottingham British Geological Survey, Available at: <http://www.bgs.ac.uk/mineralsuk/statistics/home.html>

Chavasse, Richard (2016) Expert consultation.

European Commission. (2014) Report on critical raw materials for the EU. Available at: [https://ec.europa.eu/growth/sectors/raw-materials/specific-interest/critical\\_en](https://ec.europa.eu/growth/sectors/raw-materials/specific-interest/critical_en)

Eurostat (2016b). Annual detailed enterprise statistics for industry (NACE Rev. 2, B-E). [online] Available at: [http://ec.europa.eu/eurostat/en/web/products-datasets/-/SBS\\_NA\\_IND\\_R2](http://ec.europa.eu/eurostat/en/web/products-datasets/-/SBS_NA_IND_R2)

Eurostat (2016c). International trade in goods database (COMEXT) [online]. <http://ec.europa.eu/eurostat/data/database>

Eurostat (2019). International Trade Easy Comext Database [online] Available at: <http://epp.eurostat.ec.europa.eu/newxtweb/>

ITA (2013) International Titanium Association, European conference. Available at: <http://c.ymcdn.com/sites/www.titanium.org/resource/resmgr/docs/titaniumeuropa2013conference.pdf>



Korchynsky, M. (2004). The Role of Micro alloyed Steels in the Age of Explosive Growth of Steel Usage. *Iron and Steel*, Vol. 40, Supplement, Nov. 2005, pp.3-8. Available at: <http://vanitec.org/images/papers/2005-The-Role-of-Microalloyed-Steels-in-the-Age-of-Explosive-Growth-of-Steel-Usage.pdf>

Lindvall, M. (2015). Sustainable new business opportunity for a new vanadium resource. Royal Institute of Technology (KTH) Available at: <https://www.swerea.se/en/news/new-technology-will-reduce-europes-vanadium-imports>

OECD. (2016) Export restrictions on Industrial Raw Materials database [online]. [http://qdd.oecd.org/table.aspx?Subject=ExportRestrictions\\_IndustrialRawMaterials](http://qdd.oecd.org/table.aspx?Subject=ExportRestrictions_IndustrialRawMaterials)

Reichl, C. (2019). Information on vanadium ores. International Organizing Committee for the World Mining Congresses. pers. comm., 29.05.2019

SWEREA (2016). Expert consultation. M. Lindvall.

TTP Squared (2019). Expert consultation on global production of vanadium oxides. T. Perles, 31.10.2019.

USGS (2015). Minerals Yearbook: Vanadium. By Polyak, D. E. Available at: <http://minerals.usgs.gov/minerals/pubs/commodity/vanadium/myb1-2015-vanad.pdf>

Vanitec (2019). Production and consumption – 2011-2017 Vanadium statistics. Available at: <http://vanitec.org/vanadium/production-consumption>

WMD (2018) World Mining Data 2018, Reichl, C.; Schatz, M; Zsak, G. Iron and Ferro Alloy Metals, non Ferrous Metals, Precious Metals, Industrial Minerals, Mineral Fuels. Austrian Federal Ministry of Sustainability and Tourism. [online] Available at: [www.en.bmwfw.gv.at/Energy/WorldMiningData/Seiten/default.aspx](http://www.en.bmwfw.gv.at/Energy/WorldMiningData/Seiten/default.aspx)

## **28.8 Acknowledgments**

---

This factsheet was prepared by the JRC.

The authors appreciate the support of Chloé Devauze, Inextenso Innovation (IE), for valuable input from the Material System Analysis (MSA), which was conducted at the same time in parallel. They also thank the Ad Hoc Working Group on Critical Raw Materials, in particular Asko Käpyaho (Finnish Geological Survey, GTK) and Corina Hebestreit (Euromines), as well as experts participating in the vanadium session of the SCRREEN workshop for their valuable contribution and feedback.

## GETTING IN TOUCH WITH THE EU

### **In person**

All over the European Union there are hundreds of Europe Direct information centres. You can find the address of the centre nearest you at: <http://europa.eu/contact>

### **On the phone or by email**

Europe Direct is a service that answers your questions about the European Union. You can contact this service:

- by freephone: 00 800 6 7 8 9 10 11 (certain operators may charge for these calls),
- at the following standard number: +32 22999696 or
- by email via: <http://europa.eu/contact>

### **Finding information about the EU**

#### **Online**

Information about the European Union in all the official languages of the EU is available on the Europa website at: <http://europa.eu>

#### **EU publications**

You can download or order free and priced EU publications from EU Bookshop at: <http://publications.europa.eu/eubookshop>. Multiple copies of free publications may be obtained by contacting Europe Direct or your local information centre (see <http://europa.eu/contact>).

#### **EU law and related documents**

For access to legal information from the EU, including all EU law since 1951 in all the official language versions, go to EUR-Lex at: <http://eur-lex.europa.eu>

#### **Open data from the EU**

The EU Open Data Portal (<http://data.europa.eu/euodp>) provides access to datasets from the EU. Data can be downloaded and reused for free, both for commercial and non-commercial purposes.



Publications Office  
of the European Union

doi:10.2873/92480  
ISBN 978-92-76-21053-5