

# Analytical Methods

How can we characterize a supramolecular structure?

- **qualitative data** : structure of the edifice, mode of interactions
- **quantitative data (thermo and kinetics)** : stoichiometry, stability, selectivity.

- X-Ray Diffraction
  - NMR (1D, 2D)
  - UV-vis Fluorimetry
  - Mass Spectrometry
  - Circular Dichroism
  - Electrochemistry, Potentiometry (pH)
  - Microcalorimetry (Isothermal Titration Calorimetry)
  - Computational Methods
- 
- DLS dynamic light scattering: size distributions
  - SEM scanning electron microscopy
  - TEM transmission electron microscopy
  - STM scanning tunneling microscopy
  - AFM atomic force microscopy

# Mass Spectrometry/Cyclic Voltammetry

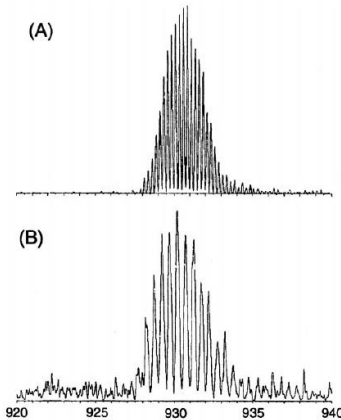
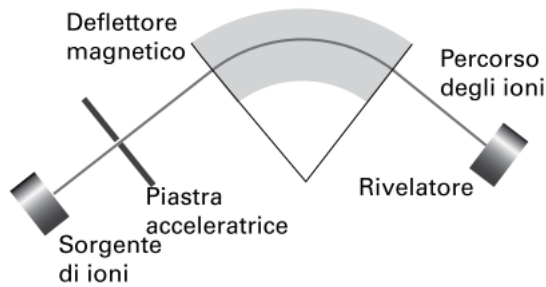
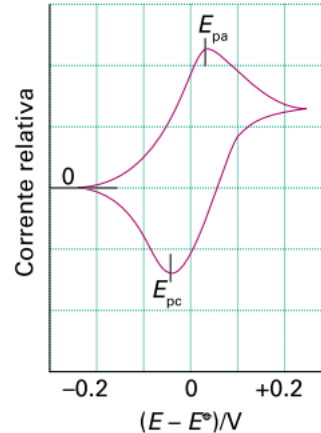


Figure 13. The isotopic patterns of 930 ( $m/z$ ): (A) dimer ( $4+$ ) and (B) monomer ( $2+$ ).

## ESI-MS

[U]<sup>2+</sup> - monomer  
[U--U]<sup>4+</sup> - dimer

Equal  $m/z$ , different line spacing in the isotopic distribution.



## CV

MISURAZ DI FLUSSO DI CORRENTE TRA ELETTRODO DI LAVORO (variaz di potenziale) E CONTROELETTRODO DI RIFERIMENTO (potenz fiss) IN MODO CICLICO

Specie redox attive in soluzione;

Processo di trasferimento  $e^-$  deve essere reversibile;

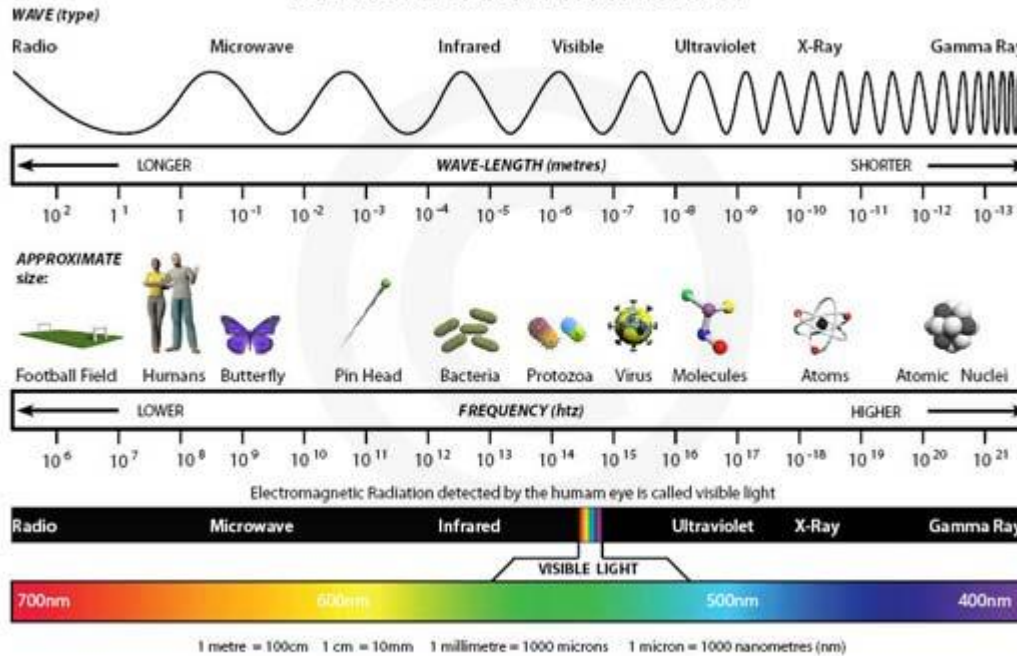
Finestra redox in cui il solvente non subisce processi redox;

Conc  $\leq$  mM;

Elettrolita di supporto che permetta conducibilità;

$$E_{\text{redox}} \text{ (V)} = (E_{\text{ox}} - E_{\text{rid}})/2.$$

# THE ELECTRO MAGNETIC SPECTRUM



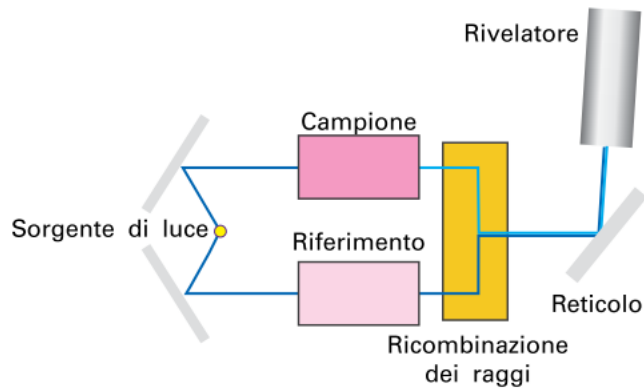
1 metre = 100cm   1 cm = 10mm   1 millimetre = 1000 microns   1 micron = 1000 nanometres (nm)

# Alcuni Metodi Fisici Applicati per la Caratterizzazione dei Composti

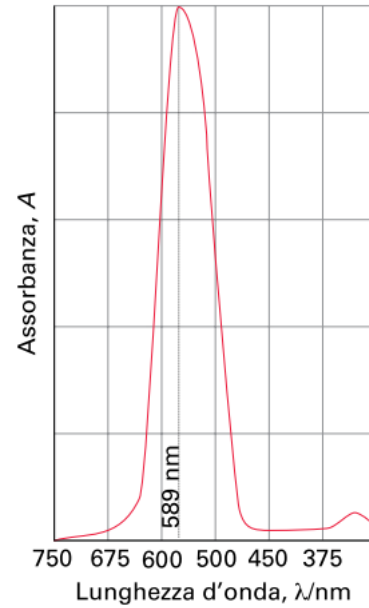
**Table 1.1** Uses of some physical techniques in determining structures

Information sought	Phase of sample		
	Gas	Liquid or solution	Solid
Fingerprint <sup>a</sup>	IR * <i>Microwave</i>  Mass spec. UV/vis * <i>UPS</i>	IR, R NMR  Mass spec. <sup>b</sup> UV/vis	IR, R Powder X-ray diffraction Mass spec. <sup>b</sup> UV/vis
Groups present	IR Mass spec. NMR	IR, R Mass spec. <sup>b</sup> NMR	IR, R Mass spec. <sup>b</sup> *NMR * <i>Mössbauer</i>
Molecular symmetry	IR <sup>c</sup> * <i>Microwave</i> **ED	IR, R NMR	IR, R *NMR ** <i>NQR</i> Single crystal X-ray diffraction
Bond lengths and angles	IR, R <sup>d</sup> * <i>Microwave</i> **ED	*** <i>EXAFS</i> LCMNR	Single crystal X-ray diffraction ***Neutron diffraction
Electronic structure <sup>e</sup>	UV/vis *UPS ESR	UV/vis ESR * <i>XPS</i>	UV/vis *UPS *XPS * <i>Mössbauer</i> ** <i>NQR</i> Single crystal X-ray and neutron diffraction

# UV-vis Absorption Spectroscopy



**Figure 8.9** Lo schema di un tipico spettrometro per assorbimento UV-visibile.



# UV-vis Absorption Spectroscopy

## Selection rules

Electronic transitions obey the following selection rules.

*Spin selection rule:*  $\Delta S = 0$

Transitions may occur from singlet to singlet, or triplet to triplet states and so on, but a change in spin multiplicity is *forbidden*.

*Laporte selection rule:* There must be a change in parity:

allowed transitions:  $g \leftrightarrow u$

forbidden transitions:  $g \leftrightarrow g$      $u \leftrightarrow u$


This leads to the selection rule:

$$\Delta l = \pm 1$$

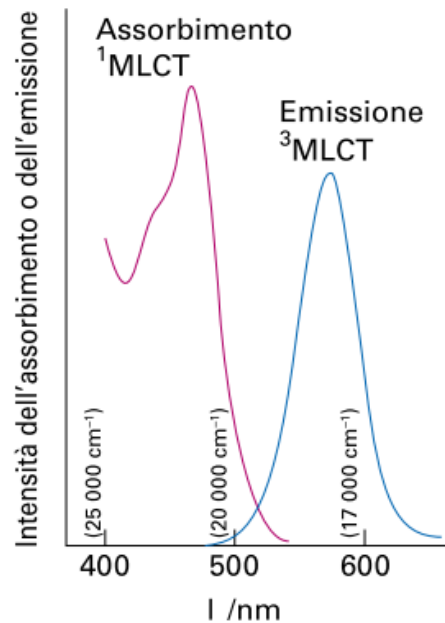
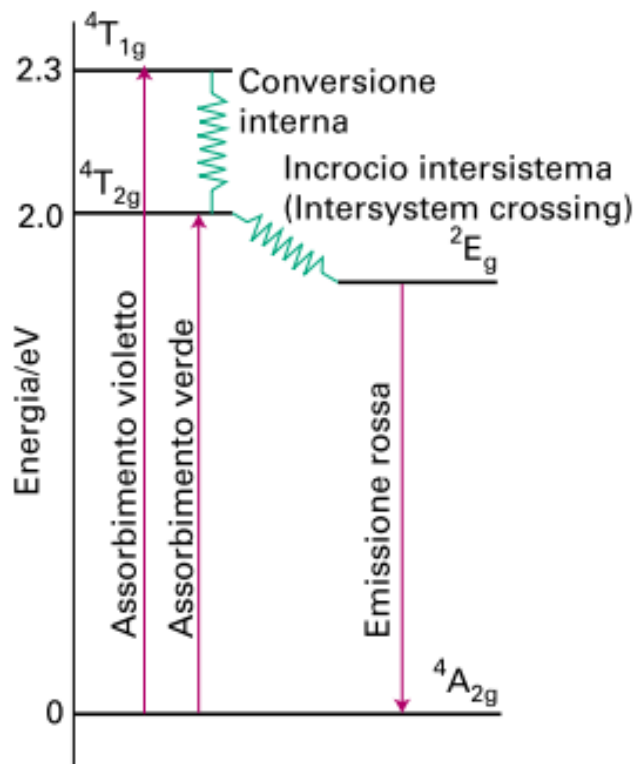
and, thus, *allowed* transitions are  $s \rightarrow p, p \rightarrow d, d \rightarrow f$ ;  
*forbidden* transitions are  $s \rightarrow s, p \rightarrow p, d \rightarrow d, f \rightarrow f$ ,  
 $s \rightarrow d, p \rightarrow f$  etc.

Type of transition	Typical $\epsilon_{\max} / \text{dm}^3 \text{mol}^{-1} \text{cm}^{-1}$
Spin-forbidden ' $d-d$ '	<1
Laporte-forbidden, spin-allowed ' $d-d$ '	1–10 10–1000
Charge transfer (fully allowed)	1000–50 000

**Table 19.2** The visible part of the electromagnetic spectrum.

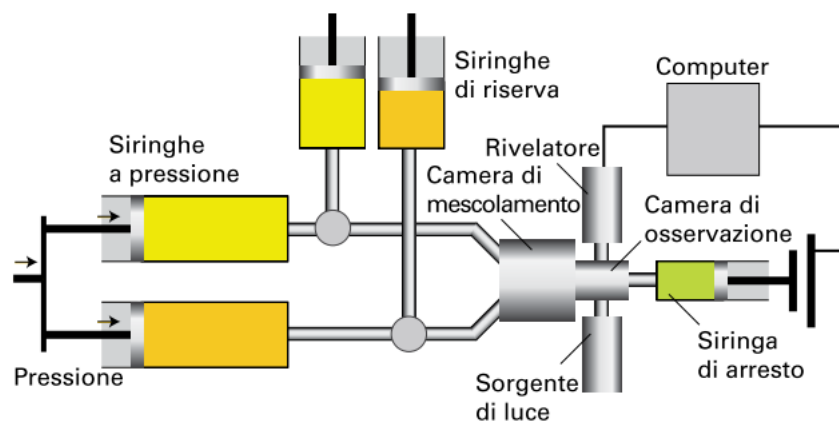
Colour of light <i>absorbed</i>	Approximate wavelength ranges / nm	Corresponding wavenumbers (approximate values) / $\text{cm}^{-1}$	Colour of light <i>transmitted</i> , i.e. complementary colour of the absorbed light	In a 'colour wheel' representation, complementary colours are in opposite sectors
Red	700–620	14 300–16 100	Green	
Orange	620–580	16 100–17 200	Blue	
Yellow	580–560	17 200–17 900	Violet	
Green	560–490	17 900–20 400	Red	
Blue	490–430	20 400–23 250	Orange	
Violet	430–380	23 250–26 300	Yellow	

# Absorption and Emission Spectroscopy

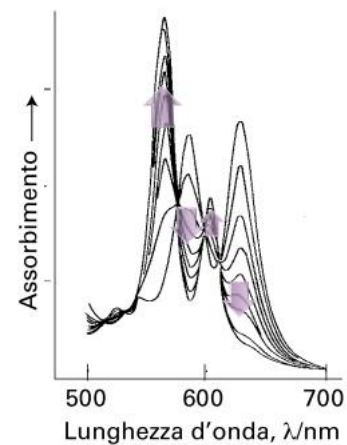


**Figura 20.36** Gli spettri di assorbimento e di fosforescenza di  $[\text{Ru}(\text{bpy})_3]^{2+}$ .

# Absorption Spectroscopy – kinetic studies



**Figure 8.14** La struttura di uno strumento *stopped-flow* per studiare reazioni veloci in soluzione.





## La spettroscopia NMR: richiami di concetti base

Una particella in moto dotata di carica possiede un momento magnetico  $\mu$  e un momento angolare  $p$ , che sono delle grandezze vettoriali quantizzate.

Per i nuclei si parla di momento magnetico TOTALE di spin nucleare e di momento angolare TOTALE di spin nucleare. Il numero quantico ad essi correlato è il numero quantico di spin nucleare  $I$ .

Per ogni isotopo di ogni elemento esiste uno stato fondamentale con  $I = n/2$  dove  $n$  è un numero intero.

Il valore di  $I$  dipende dal numero atomico  $Z$  e dal numero di massa  $A$  del nucleo:

Nuclei con  $Z$  pari e  $A$  pari hanno  $I = 0$       NMR silenti ( $^{12}\text{C}$ ,  $^{16}\text{O}$ );

Nuclei con  $Z$  dispari o pari e  $A$  dispari hanno  $n$  dispari ( $I = \frac{1}{2}, \frac{3}{2}, \frac{5}{2}$ )  
NMR attivi ( $^1\text{H}$ ,  $^{13}\text{C}$ ,  $^{15}\text{N}$ ,  $^{31}\text{P}$ );

Nuclei con  $Z$  dispari e  $A$  pari hanno  $n$  pari ( $I = \text{intero}$ ) ( $^2\text{H}$ ,  $^{14}\text{N}$ )      NMR attivi.

## La spettroscopia NMR: richiami di concetti base

Quando  $I$  è diverso da zero, il nucleo possiede un momento magnetico totale di spin nucleare  $\mu$  dato da:

$$\mu = \gamma \hbar [I(I+1)]^{1/2}$$

$\gamma$  è il rapporto giromagnetico o magnetogirico che è una costante tipica per ogni isotopo ed è correlato al numero di protoni e alla massa del nucleo ed è dato dal rapporto tra il momento magnetico totale di spin nucleare e il momento angolare totale di spin nucleare.

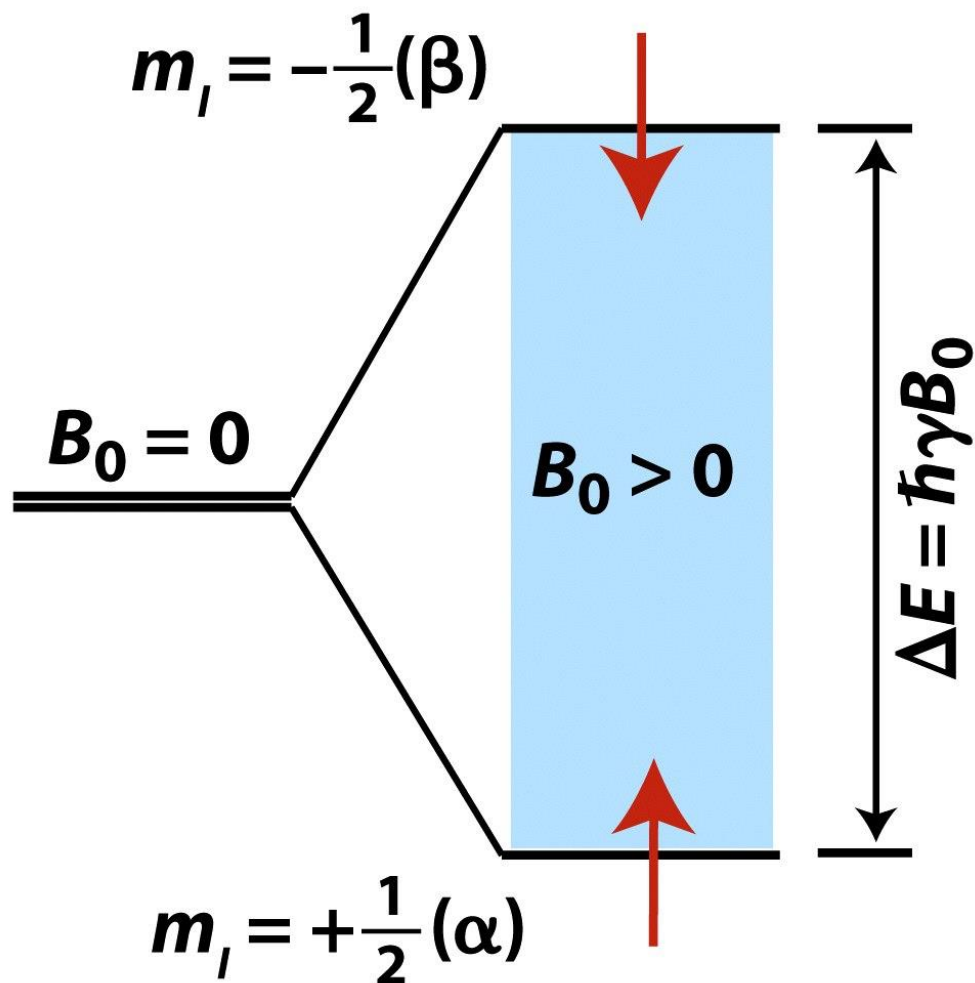
In presenza di un campo magnetico stazionario  $B_0$  l'asse di spin nucleare può assumere un dato numero di orientazioni che è legato al numero quantico magnetico  $m$

$$m = I, I-1, I-2, \dots - I$$

il numero totale di orientazioni possibili è  $2I+1$

## La spettroscopia NMR: richiami di concetti base

Orientazioni possibili per nuclei con  $I = 1/2$



I livelli energetici NON sono preesistenti: vengono creati da  $B_0$ .

La differenza di energia tra i livelli energetici NON è costante: dipende da  $B_0$ .

## La spettroscopia NMR: richiami di concetti base

Quando si irradia il campione con una radiazione elettromagnetica che ha una frequenza, e quindi un'energia pari a  $\Delta E$ , avviene la transizione tra i livelli energetici secondo la regola di selezione  $\Delta m = \pm 1$ .

Questa frequenza si chiama FREQUENZA DI LARMOR

$$\nu_0 = \gamma / 2\pi B_0$$

E' la frequenza con cui il momento magnetico di spin nucleare precessa intorno alla direzione di  $B_0$ .

La sensibilità della spettroscopia NMR dipende dalla differenza di popolazione tra i due livelli e quindi dipende da  $B_0$  e da  $\gamma$ .

## La spettroscopia NMR: richiami di concetti base

Quando si irradia il campione con una radiazione elettromagnetica che ha una frequenza, e quindi un'energia pari a  $\Delta E$ , avviene la transizione tra i livelli energetici secondo la regola di selezione  $\Delta m = \pm 1$ .

Questa frequenza si chiama FREQUENZA DI LARMOR

$$\nu_0 = \gamma / 2\pi B_0$$

E' la frequenza con cui il momento magnetico di spin nucleare precessa intorno alla direzione di  $B_0$ .

La sensibilità della spettroscopia NMR dipende dalla differenza di popolazione tra i due livelli e quindi dipende da  $B_0$  e da  $\gamma$ .

## La spettroscopia NMR: richiami di concetti base

**Table 2.1** NMR properties of some spin 1/2 nuclei

**Nuclei con I = 1/2**

Isotope	Natural abundance/%	Magnetogyric ratio <sup>a</sup> /10 <sup>7</sup> rad T <sup>-1</sup> s <sup>-1</sup>	Relative NMR frequency/MHz	Relative receptivity
<sup>1</sup> H	99.985	26.7519	100.0	1.00
<sup>2</sup> H	—	28.535	106.7	—
<sup>3</sup> He	0.00013	-20.380	76.2	5.8 × 10 <sup>-7</sup>
<sup>13</sup> C	1.11	6.7283	25.1	1.8 × 10 <sup>-4</sup>
<sup>15</sup> N	0.37	-2.712	10.1	3.9 × 10 <sup>-6</sup>
<sup>19</sup> F	100.0	25.181	94.1	8.3 × 10 <sup>-1</sup>
<sup>29</sup> Si	4.7	-5.3188	19.9	3.7 × 10 <sup>-4</sup>
<sup>31</sup> P	100.0	10.841	40.5	6.6 × 10 <sup>-2</sup>
<sup>57</sup> Fe	2.2	0.8661	3.2	7.4 × 10 <sup>-7</sup>
<sup>77</sup> Se	7.6	5.12	19.1	5.3 × 10 <sup>-4</sup>
<sup>80</sup> Y	100.0	-1.3155	4.9	1.2 × 10 <sup>-4</sup>
<sup>103</sup> Rh	100.0	-0.846	3.2	3.2 × 10 <sup>-5</sup>
<sup>107</sup> Ag	51.8	-1.087	4.0	3.5 × 10 <sup>-5</sup>
<sup>109</sup> Ag	48.2	-1.250	4.7	4.9 × 10 <sup>-5</sup>
<sup>111</sup> Cd	12.8	-5.6926	21.2	1.2 × 10 <sup>-3</sup>
<sup>113</sup> Cd	12.3	-5.9550	22.2	1.3 × 10 <sup>-3</sup>
<sup>117</sup> Sn <sup>b</sup>	7.6	-9.578	35.6	3.5 × 10 <sup>-3</sup>
<sup>119</sup> Sn	8.6	-10.021	37.3	4.5 × 10 <sup>-3</sup>
<sup>125</sup> Te <sup>b</sup>	7.0	-8.498	31.5	2.2 × 10 <sup>-3</sup>
<sup>129</sup> Xe	26.4	-7.441	27.8	5.7 × 10 <sup>-3</sup>
<sup>169</sup> Tm	100.0	-2.21	8.3	5.7 × 10 <sup>-4</sup>
<sup>171</sup> Yb	14.3	4.712	17.6	7.8 × 10 <sup>-4</sup>
<sup>183</sup> W	14.4	1.120	4.2	1.1 × 10 <sup>-5</sup>
<sup>187</sup> Os	1.6	0.616	2.3	2.0 × 10 <sup>-7</sup>
<sup>195</sup> Pt	33.8	5.768	21.4	3.4 × 10 <sup>-3</sup>
<sup>199</sup> Hg	16.8	4.8154	17.9	9.8 × 10 <sup>-4</sup>
<sup>203</sup> Tl	29.5	15.436	57.1	5.7 × 10 <sup>-2</sup>
<sup>205</sup> Tl	70.5	15.589	57.6	1.4 × 10 <sup>-1</sup>
<sup>207</sup> Pb	22.6	5.540	20.9	2.0 × 10 <sup>-3</sup>

<sup>a</sup> G.H. Fuller, *J. Phys. Chem. Ref. Data* 5, 835 (1976). <sup>b</sup> Other spin 1/2 isotopes also exist.

## La spettroscopia NMR: richiami di concetti base

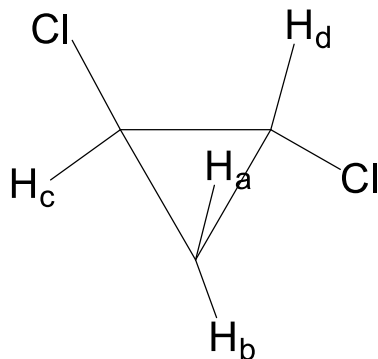
**Nuclei chimicamente e/o magneticamente equivalenti.**

**Nuclei chimic. equiv.:** sono nuclei che si convertono l'uno nell'altro con un'operazione di simmetria applicata alla molecola o sono equivalenti nel tempo per effetto di un processo dinamico intramolecolare veloce.

**I nuclei chimc. equiv. sono isocroni:** hanno lo stesso chemical shift.

**Nuclei magnet. equiv.:** sono nuclei che sono chimic. equiv. e che accoppiano allo stesso modo con gli altri nuclei della molecola.

**I nuclei magnet. equiv. hanno la stessa J.**



**H<sub>a</sub> e H<sub>b</sub> sono chimicamente ma NON magneticamente equivalenti.**

## La spettroscopia NMR: richiami di concetti base

La struttura fine del segnale: deriva dall'accoppiamento tra i nuclei, si parla di costanti di accoppiamento  ${}^nJ$ , dove  $n$  è il numero di legami tra i nuclei che accoppiano:

${}^1J$  diretta

${}^2J$  geminale

${}^3J$  vicinale

${}^4J, {}^5J$  long range

Per accoppiamenti omonucleari  ${}^1\text{H}-{}^1\text{H}$   $J$  18 Hz o meno;

Per accoppiamenti eteronucleari  ${}^1\text{H}-\text{X}$   $J$  centinaia di Hz;

Per accoppiamenti omo- o eteronucleari  $\text{X}-\text{X}$  o  $\text{Y}-\text{X}$   $J$  kHz.

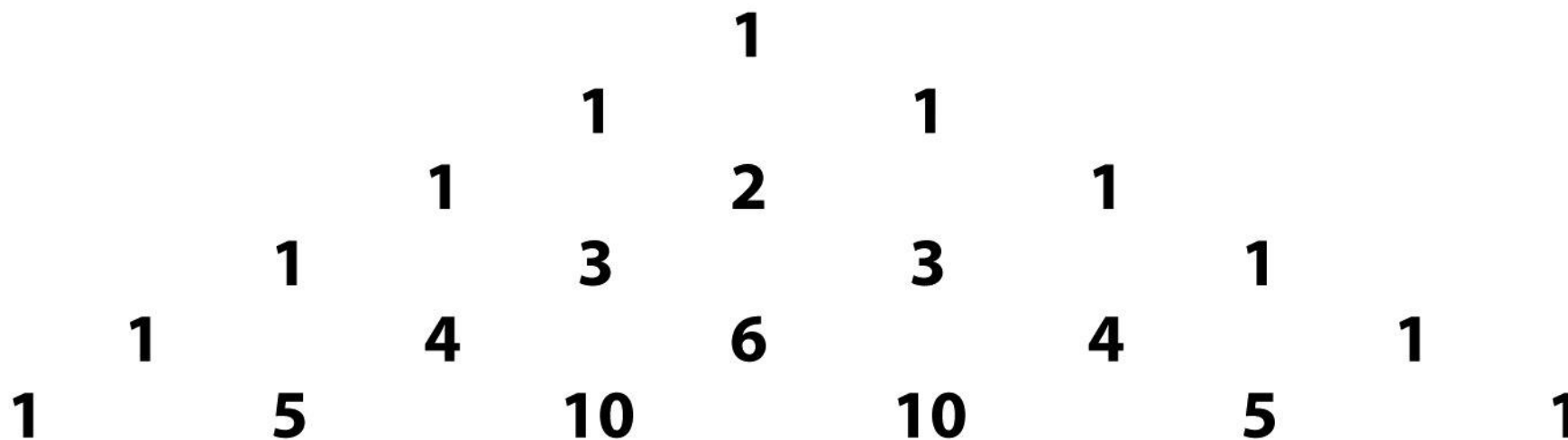


## La spettroscopia NMR: richiami di concetti base

Numero di linee per sistemi di spin del primo ordine è  $(2nI + 1)$   
con  $n$  = numero di nuclei che accoppiano con il nucleo in esame,

$I$  = numero quantico di spin dei nuclei che accoppiano;

Per nuclei con  $I = \frac{1}{2}$  l'intensità relativa delle linee  
è data dal Triangolo di Pascal



## 1 Pascal's triangle

## Spettroscopia NMR bidimensionale: **cenni**

**Gli spettri bidimensionali possono essere:**

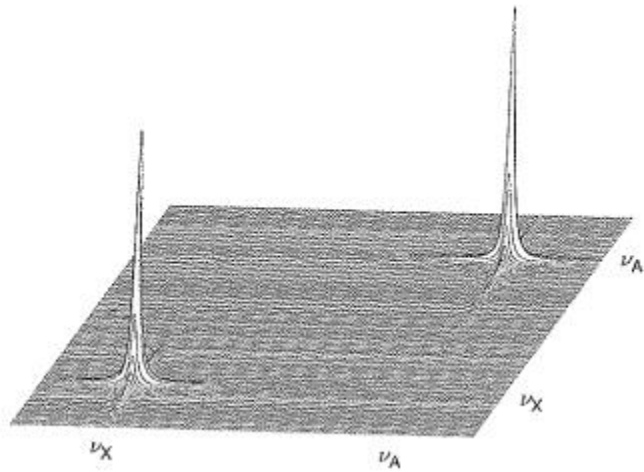
**Omonucleari: hanno la scala di frequenze dello stesso isotopo sulle due dimensioni;**

**Eteronucleari: hanno la scala di frequenze di un isotopo su una dimensione e di un isotopo diverso sull'altra.**

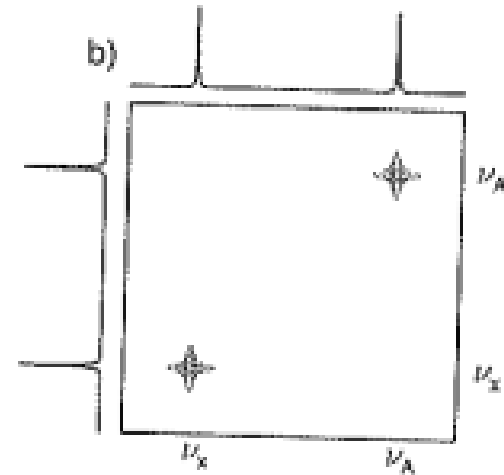
**Gli spettri bidimensionali che danno informazioni sui nuclei che accoppiano si chiamano spettri J correlati e gli esperimenti NMR relativi si chiamano esperimenti di COSY (CORrelated SpectroscopY).**

# Spettroscopia NMR bidimensionale: rappresentazione degli spettri

Spettro bidimensionale risultante dalla sequenza COSY per un campione avente due nuclei NON accoppiati.



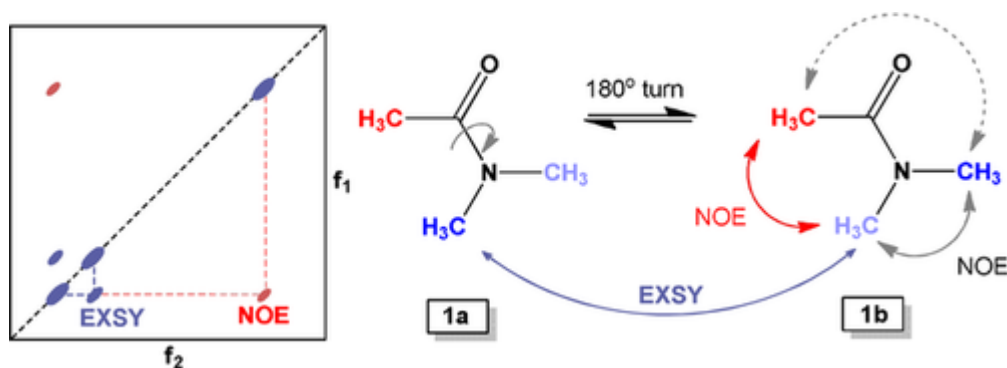
Equivalente rappresentazione a contorni.



# Nuclear Overhauser Effect NMR spectroscopy (NOESY) Exchange spectroscopy (EXSY)

Useful for determining which signals arise from NMR-active nucleus that are close to each other in space even if they are not bonded;

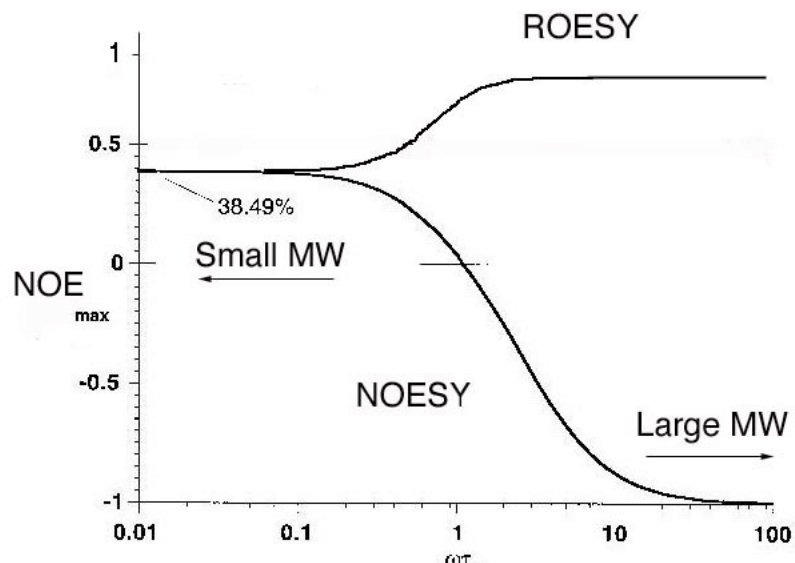
NOESY also detects chemical and conformational exchange (termed often EXSY-exchange spectroscopy-in this case); nOe may be observed between protons that are up to **4Å** apart, while the upper limit for large molecules is about **5Å**.



# Rotating frame Overhouser Effect NMR spectroscopy (ROESY)

## Molecular Weight and Maximum NOE

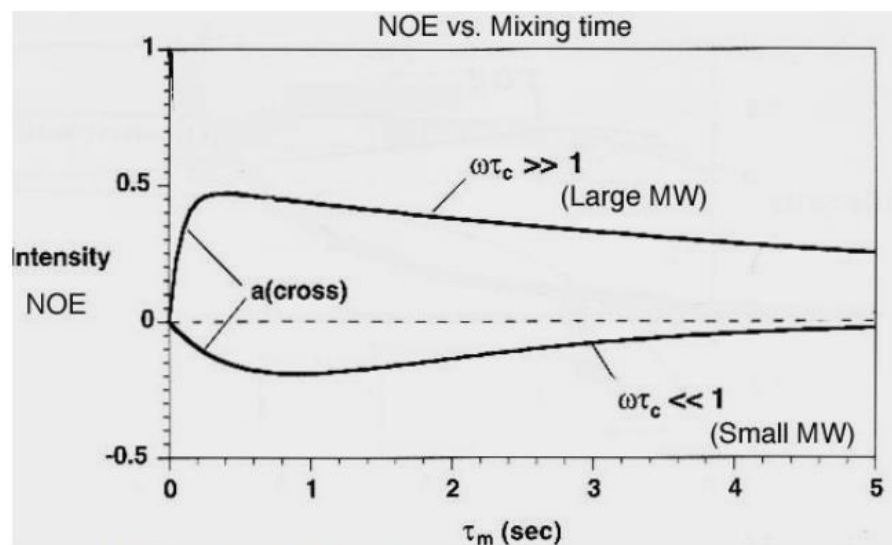
The maximum possible NOE depends on the correlation time (or approximately the inverse of the rate of molecular tumbling), which is in large part determined by the molecular weight and solvent viscosity. Larger molecular weights and higher viscosities lead to larger correlation times. The NOE is positive for small molecules ( $MW < 600$ ), goes through zero for medium-sized molecules ( $MW$  range 700 – 1200), and becomes negative for large molecules ( $MW > 1200$ ). (These MW ranges are approximate only.) For medium sized molecules, the NOE may be theoretically zero. See the figure below that is adapted from Newhaus and Williamson text. The ROESY experiment (rotating frame NOE) is preferred for medium-sized molecules since the ROE is always positive.



## Time Dependence of NOE - Mixing Times

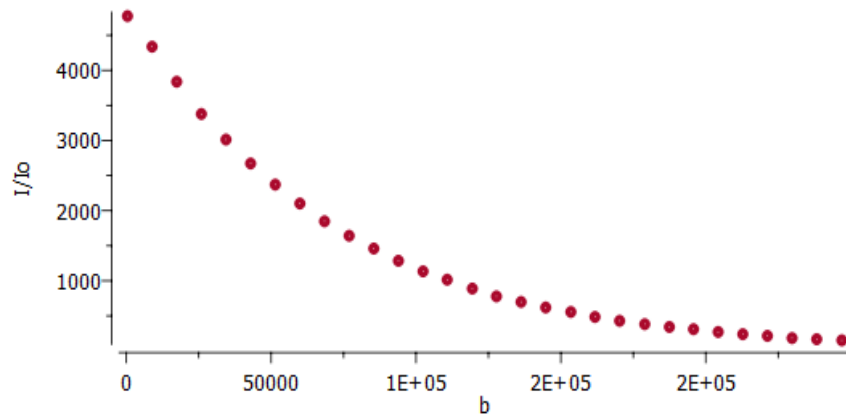
In transient experiments, such as NOESY and ROESY, the NOE dynamically builds up and then decays due to relaxation during the mixing time, as shown below in the plot of NOE versus mixing time. The NOE, thus, goes through a maximum as function of mixing time. The location of the maximum NOE and rate of build-up depend on the correlation time, or its proxy, the molecular weight, and the distance between protons for a particular NOE. In general, large molecules build-up NOE quickly while small molecules build-up NOE more slowly. That is, for large molecules the point of maximum NOE is shifted to shorter mixing times. A shorter distance between protons will also lead to faster build-up of NOE and a shift of the maximum to shorter mixing times.

There is only one mixing time specified per NOE experiment, and it is the most important parameter for NOE experiments. For small molecules, a mixing time that maximizes the NOE is desirable, unless you intend to calculate an actual distance (see analysis section). Generally, one is interested in a range of distances so the choice depends on molecular weight rather than a particular distance. For large molecules, the mixing time must be kept small so that the build-up obeys the linear approximation and spin diffusion is avoided (see analysis section). The following are guidelines:



- 1) small molecules 0.5 -1 sec. Start with 0.5 sec.
- 2) medium size molecules 0.1 -0.5 sec. Start with 0.25 sec.
- 3) large molecules 0.05 - 0.2 sec. Start with 0.1 sec.

# Diffusion-Ordered NMR spectroscopy (DOSY)

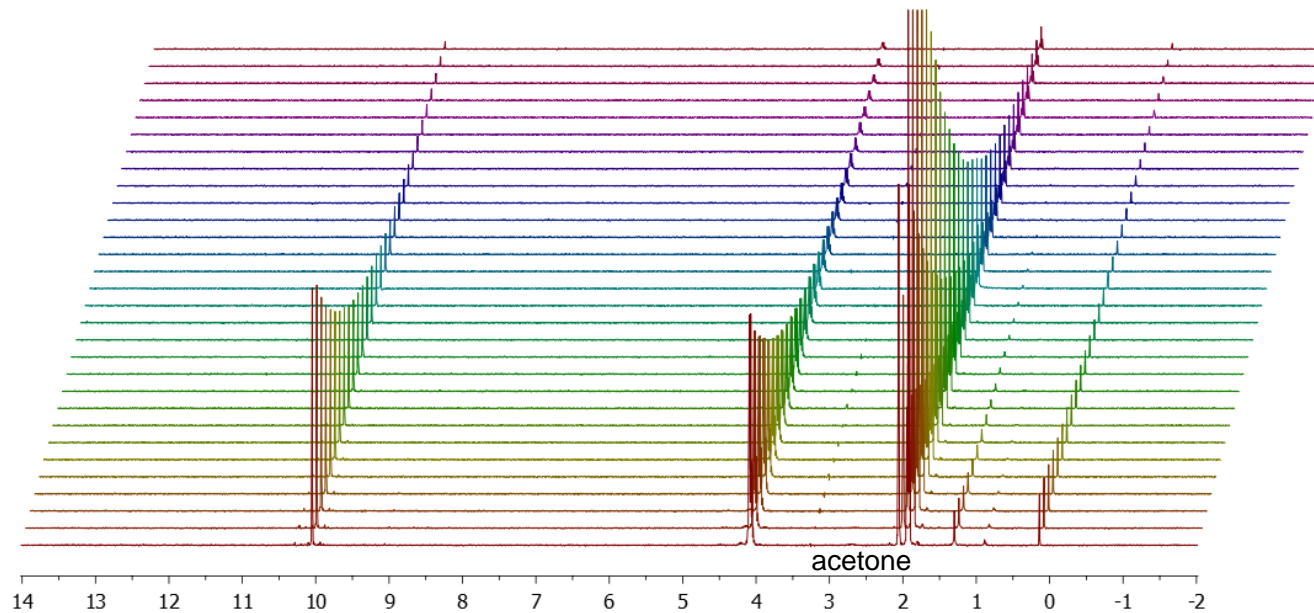


$$\ln \frac{I}{I_0} = -bD$$

Stejskal-Tanner  
equation

$$r_H = \frac{k_B T}{6\pi\eta D}$$

Stokes-Einstein  
equation



# Diffusion-Ordered NMR spectroscopy (DOSY)

TUTORIAL REVIEW

www.rsc.org/csr | Chemical Society Reviews

## Determining accurate molecular sizes in solution through NMR diffusion spectroscopy

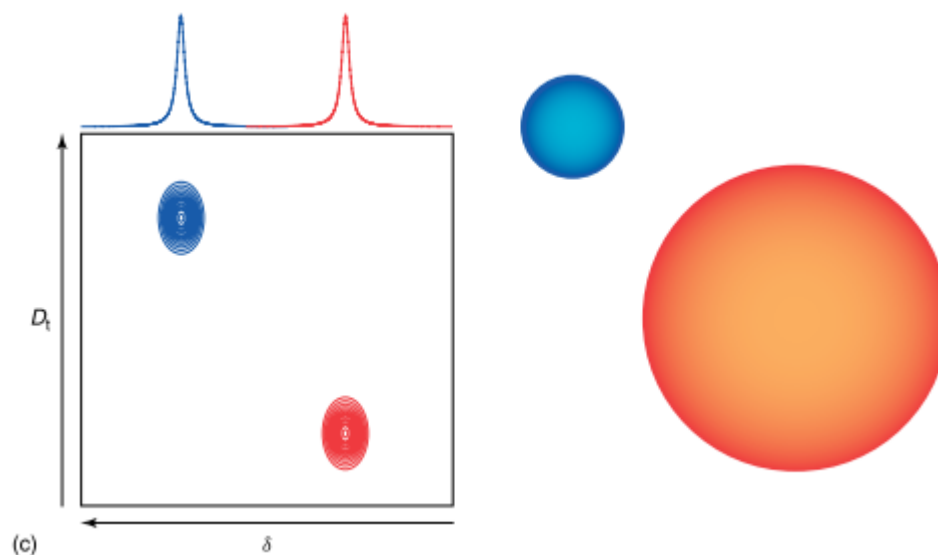
Alceo Macchioni,\* Gianluca Ciancaleoni, Cristiano Zuccaccia and Daniele Zuccaccia

Received 21st September 2007

First published as an Advance Article on the web 11th October 2007

DOI: 10.1039/b615067p

*Chem. Soc. Rev.*, 2008, **37**, 479–489





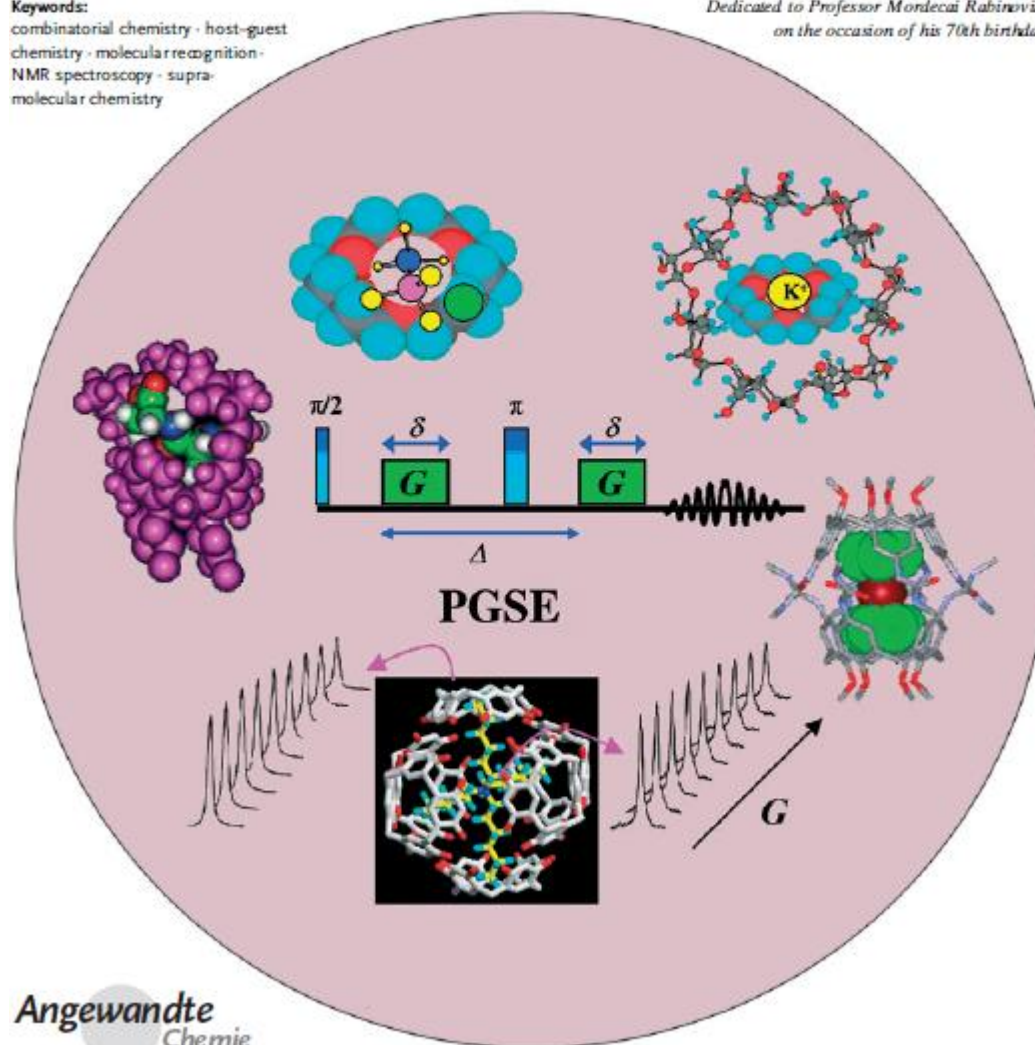
# Diffusion NMR Spectroscopy in Supramolecular and Combinatorial Chemistry: An Old Parameter—New Insights

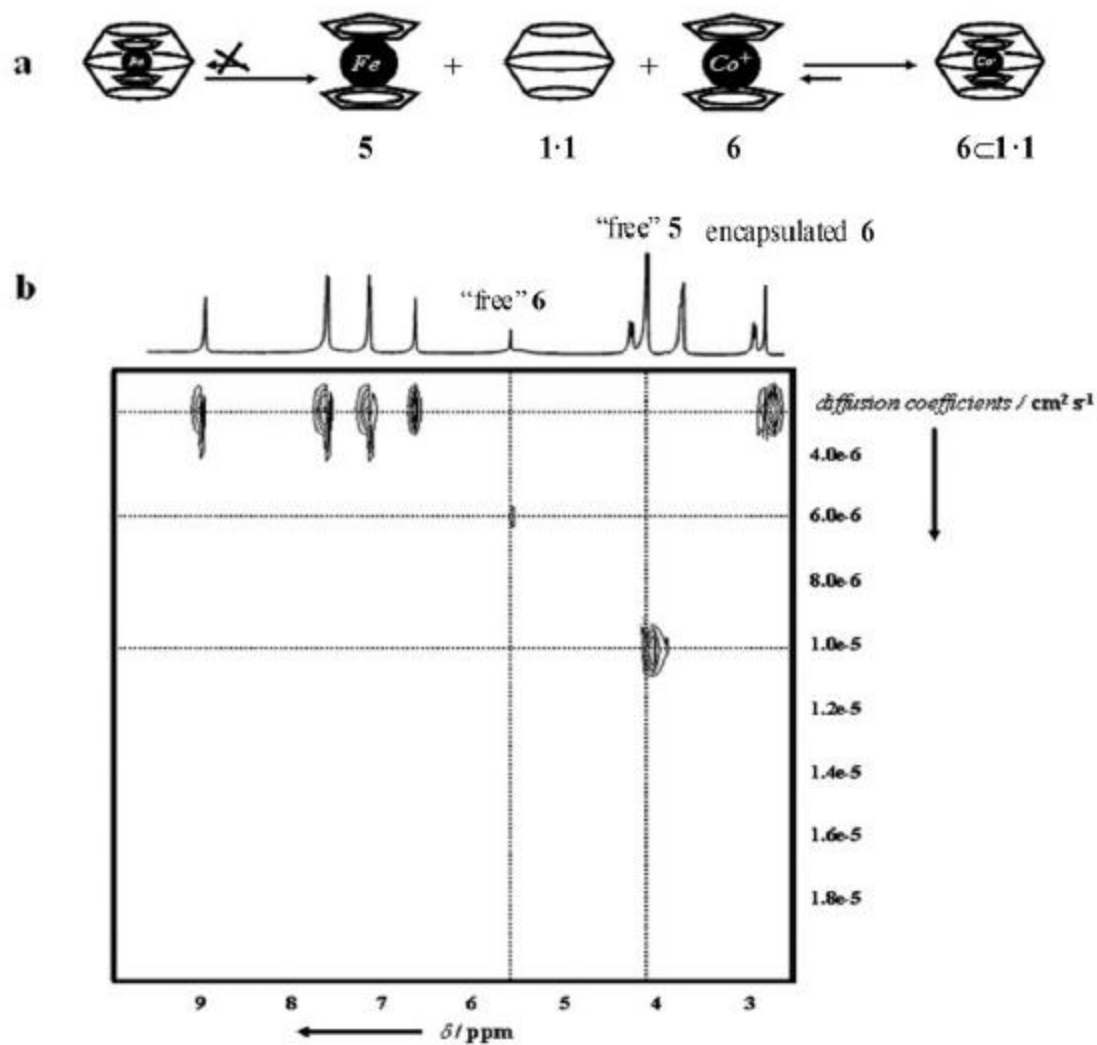
Yoram Cohen,\* Liat Avram, and Limor Frish

## Keywords:

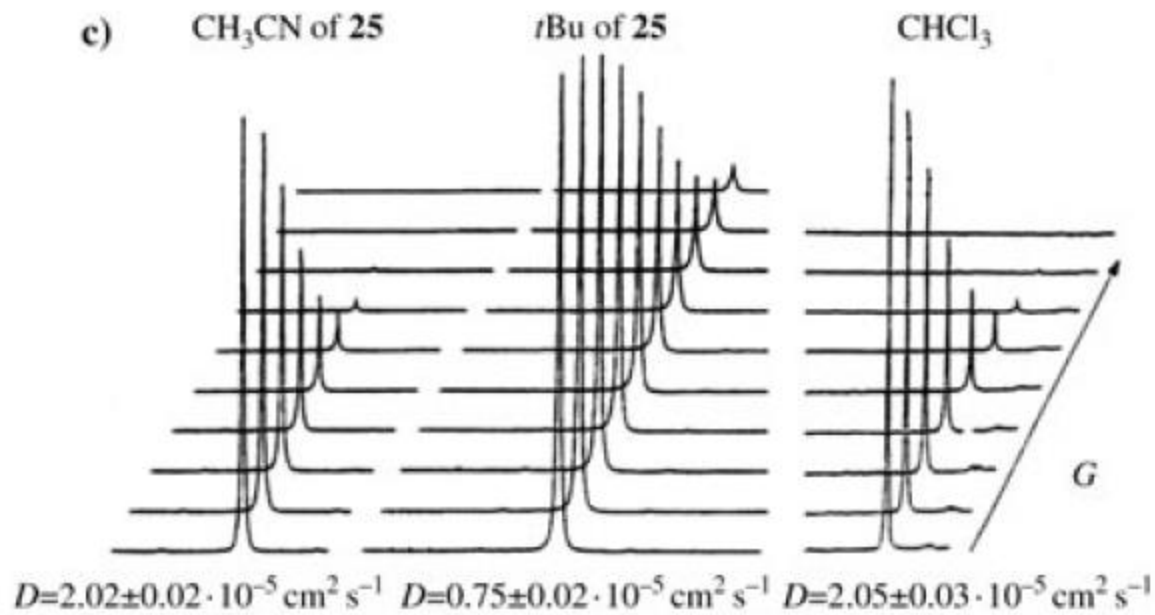
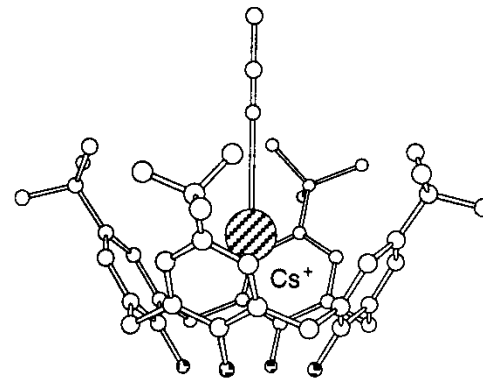
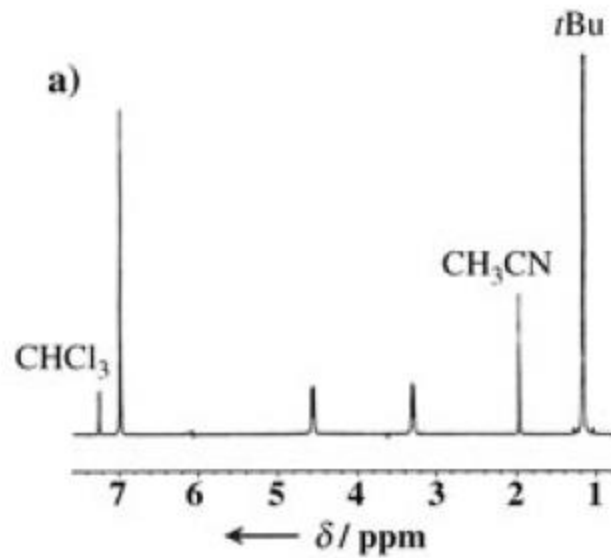
combinatorial chemistry · host-guest chemistry · molecular recognition · NMR spectroscopy · supramolecular chemistry

Dedicated to Professor Mordecai Rabinovitz  
on the occasion of his 70th birthday





**Fig. 3** (a) Schematic representation of the reaction of **5** and **6** with **1**<sub>2</sub>, and (b) the DOSY spectrum (400 MHz, 298 K) of the C<sub>2</sub>D<sub>4</sub>Cl<sub>2</sub> solution of **1**<sub>2</sub> in the presence of **5** and **6**.<sup>38</sup> Adapted with permission from ref. 19b, copyright © 2012 WILEY-VCH Verlag GmbH & Co. KGaA, Weinheim.



# La scala dei tempi

**Il tempo durante il quale un quanto della radiazione interagisce con la molecola**

**Nella diffrazione dei raggi X un fotone interagisce con la molecola in  $10^{-16}$  -  $10^{-19}$  s, tempo inferiore alle vibrazioni ( $10^{-13}$  -  $10^{-14}$  s), rotazioni ( $10^{-10}$  -  $10^{-12}$  s) molecolari.**



**Il fotone vede la molecola in una struttura istantanea: in uno stato vibrazionale, rotazionale FISSO.**

## La scala dei tempi

L'interazione tra la radiazione elettromagnetica e la materia genera dei processi nella molecola che avvengono in determinati tempi.

E' di fondamentale importanza considerare la correlazione tra la scala dei tempi della tecnica in uso e la scala dei tempi del processo molecolare.

### Scala dei tempi di alcune tecniche di caratterizzazione

Diffrazione di raggi X	$10^{-18}$ s
Mössbauer	$10^{-18}$ s
Spettroscopia elettronica UV/Visibile	$10^{-15}$ s
Spettroscopia vibrazionale IR/Raman	$10^{-12}$ s
NMR	c. $10^{-3}$ - $10^{-6}$ s
EPR	$10^{-6}$ s

# La scala dei tempi

## Il tempo di vita dello stato eccitato della molecola

Riguarda spettroscopie che comportano il passaggio da uno stato fondamentale ad uno stato eccitato: UV-Visibile, IR, NMR, ...

Lo stato eccitato ha un suo tempo di vita che è il tempo necessario per passare dallo stato eccitato a un livello energetico inferiore: TEMPO di RILASSAMENTO.

Principio di Indeterminazione di Heisenberg:

$$\tau \Delta E = h$$

$\tau$  è il tempo di vita dello stato eccitato;  $\Delta E$  è l'incertezza sulla sua energia

$$h \approx 10^{-34} \text{ J s}$$

$\Delta \nu = \Delta E/h = h/2\pi\tau h \approx 1/\tau$  incertezza sulla frequenza

Es:  $\tau = 10^{-15}$  s per spettro elettronico

$$\Delta \nu = 10^{15} \text{ Hz}$$

stesso range di UV-Vis.

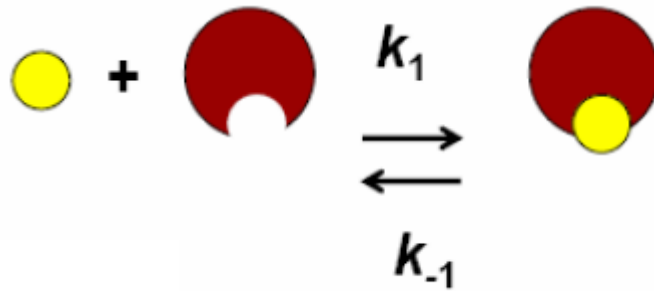
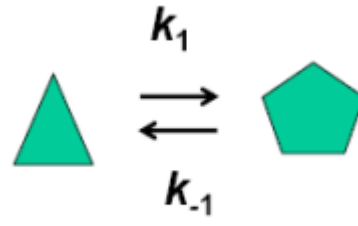
Spettri con BANDE LARGHE!

# Le scale dei tempi associate alle tecniche spettroscopiche

**Table 1.2** Timescales associated with some spectroscopic techniques

Technique	Energy of excited state (Hz)	Typical relaxation time (seconds)	Typical linewidth (Hz)
NMR (solution)	$10^8$	10	$10^{-1}$
ESR (solution)	$10^{10}$	$10^{-5}$	$10^5$
Rotational spectroscopy (gas)	$10^{11}$	$10^{-4}$	$10^4$
Vibrational spectroscopy (gas)	$10^{14}$	$10^{-8}$	$10^8$
Electronic spectroscopy (solution)	$10^{16}$	$10^{-15}$	$10^{15}$
Mössbauer spectroscopy (solid)	$10^{19}$	$10^{-8}$	$10^8$

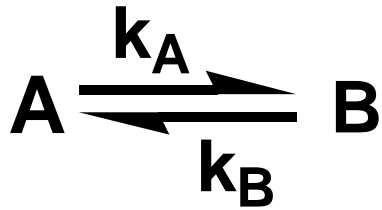
## Lo scambio chimico





# Lo scambio chimico

Scambio tra due siti che non accoppiano con uguale popolazione



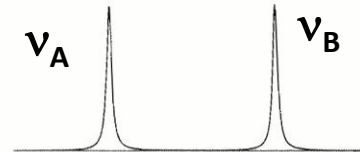
$$p_a = p_b = 0.50$$

$$v_i = p_a v_a + p_b v_b$$

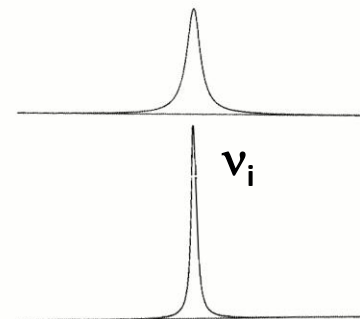
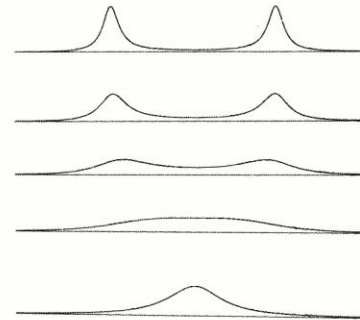
Temperatura di coalescenza

Temp. 1 < Temp. 2

Temp. 1



Scambio lento

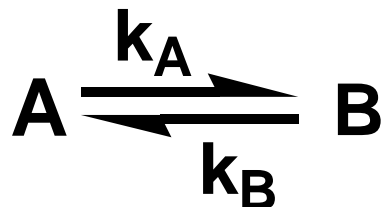


Temp. 2

Scambio veloce

# Lo scambio chimico

## Scambio tra due siti che non accoppiano con diversa popolazione



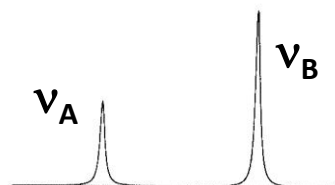
$$p_a = 0.33 \quad p_b = 0.66$$

$$v_i = p_a v_a + p_b v_b$$

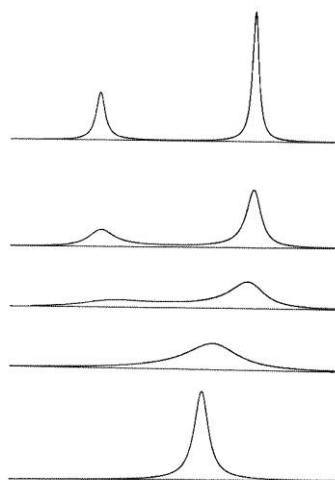
Temperatura di coalescenza

Temp. 1 < Temp. 2

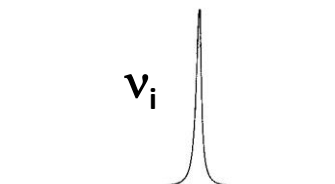
Temp. 1



Scambio lento

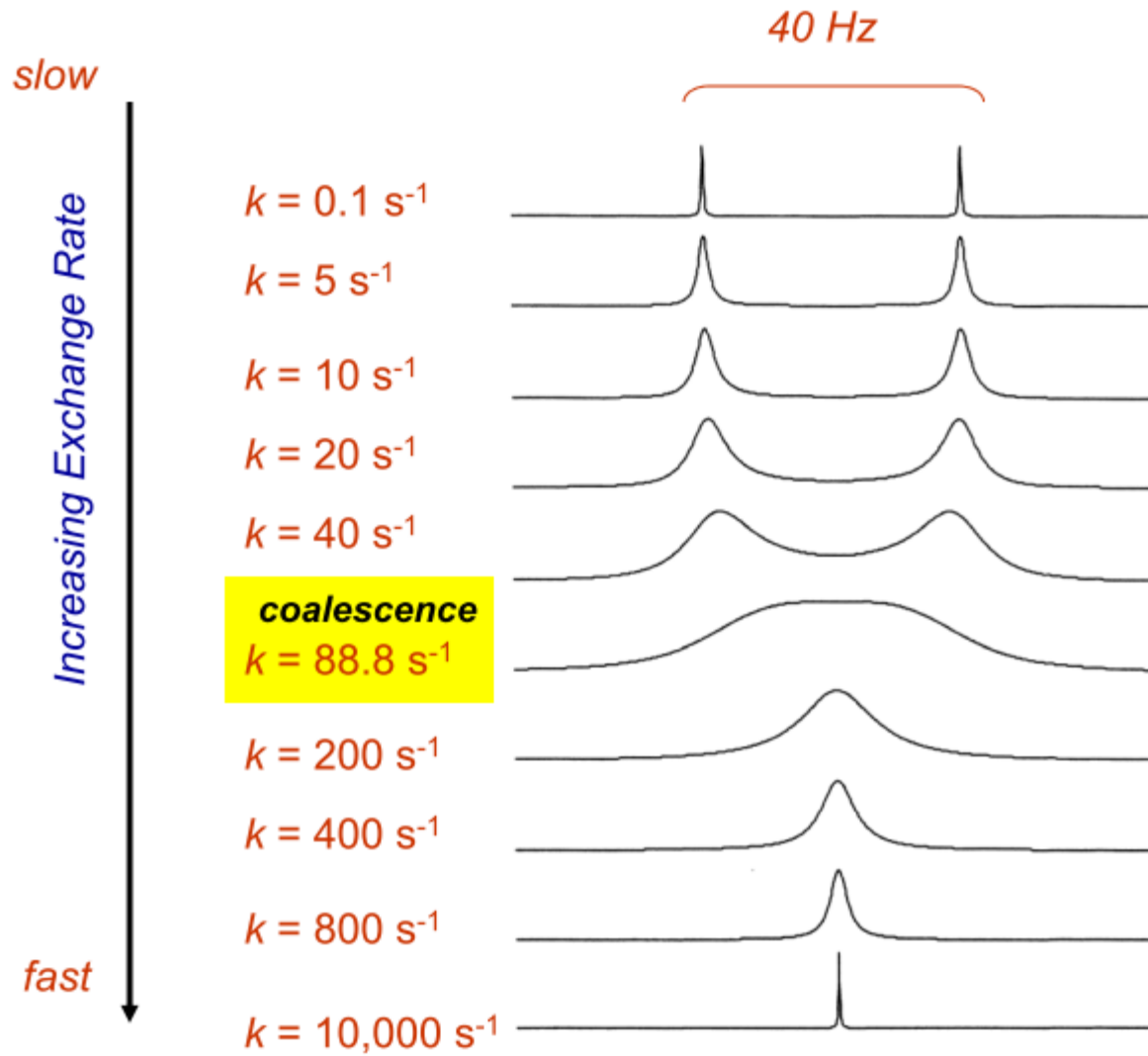


Temp. 2

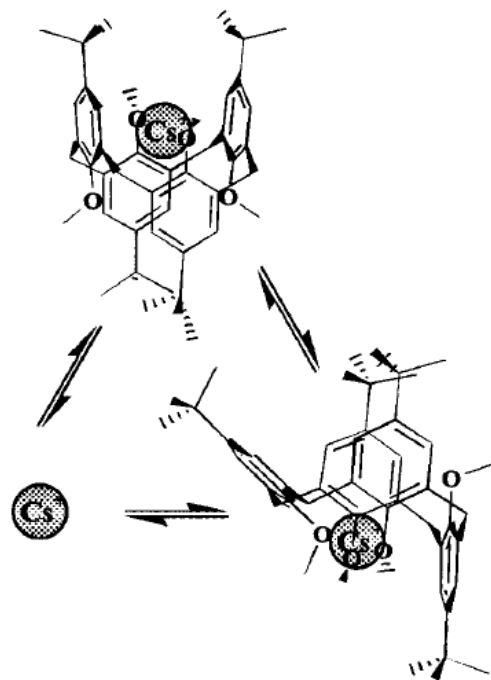


Scambio veloce

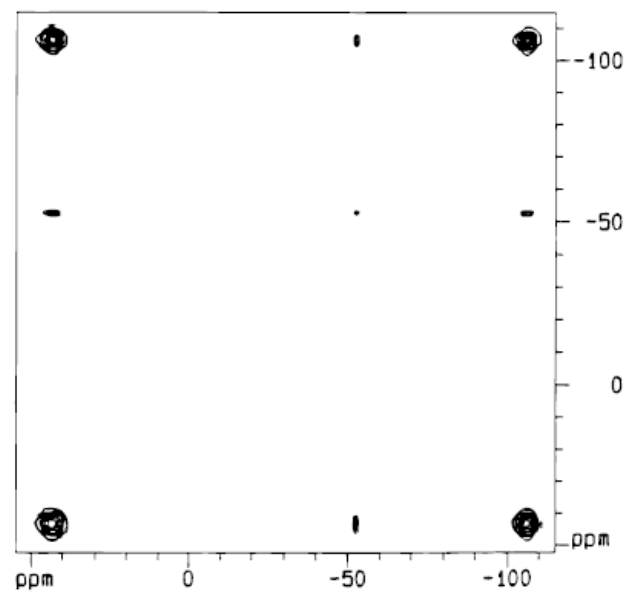
# Lo scambio chimico



**1,3-alternate, Cs<sup>+</sup> complex**



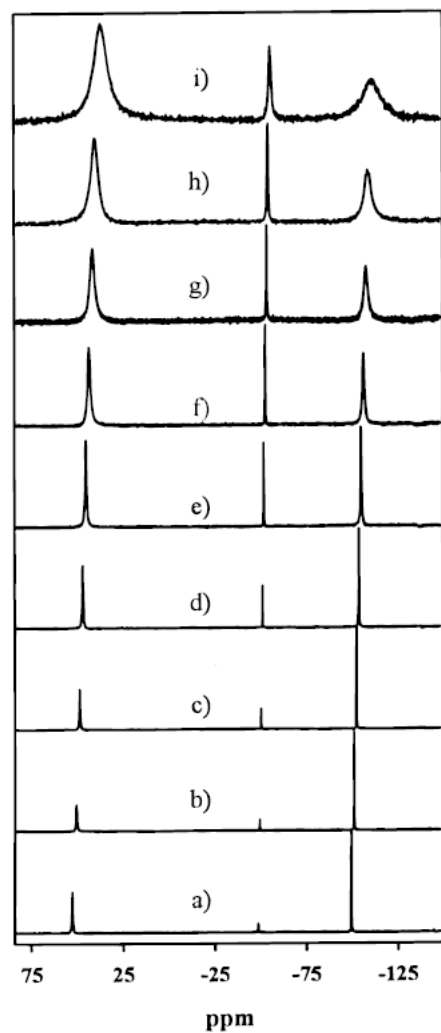
**partial cone, Cs<sup>+</sup> complex**



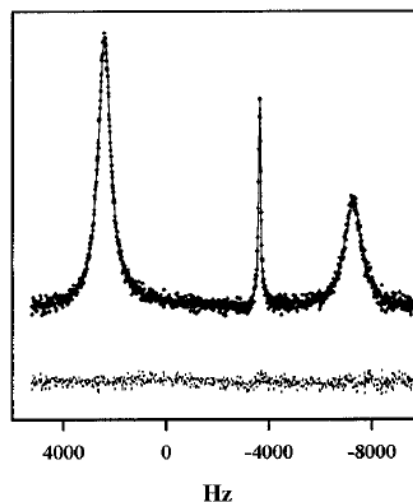
**Figure 5.** <sup>133</sup>Cs 2D-EXSY spectrum of [1] = 43.3 mM, [CsI<sub>3</sub>] = 80.4 mM at 283 K: mixing time ( $\tau_m$ ) = 0.1 s.

# Lineshape analysis – determination of kinetic constants at different Temperatures

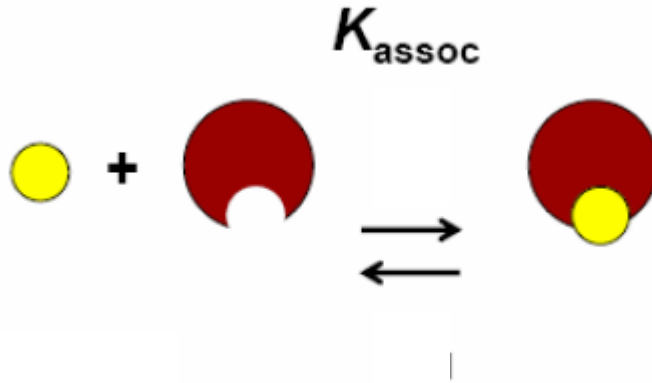
(suitable for the study of exchange processes on timescales from 10  $\mu$ s to 100 ms)



**Figure 3.**  $^{133}\text{Cs}$  NMR spectra of  $\text{CsI}_3$  80.4 mM, in the presence of 43.3 mM tetramethoxycalix[4]arene (**1**). The spectra were recorded at various temperatures: 236 (a), 246 (b), 254 (c), 264 (d), 274 (e), 283 (f), 292 (g), 300 (h), and 314 K (i).

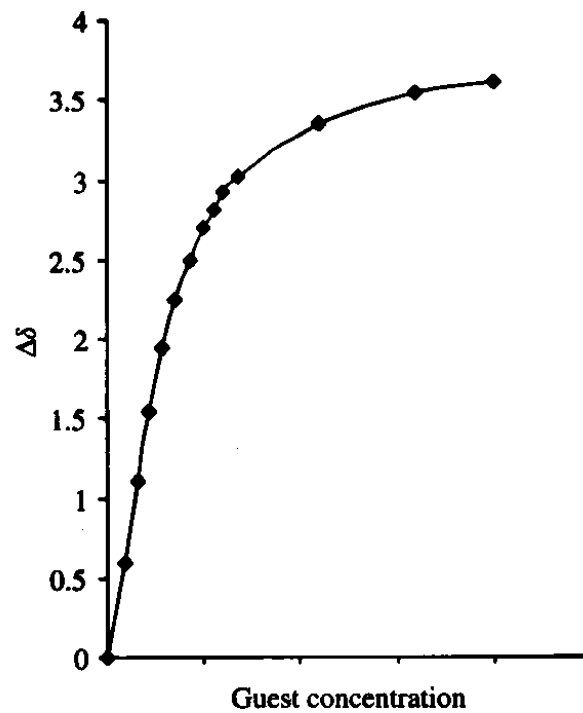


**Figure 4.**  $^{133}\text{Cs}$  NMR spectra of **1** = 43.3 mM,  $[\text{CsI}_3] = 80.4$  mM at 314 K showing the measured spectrum, the fit (solid line) from DNMR5, and the difference.

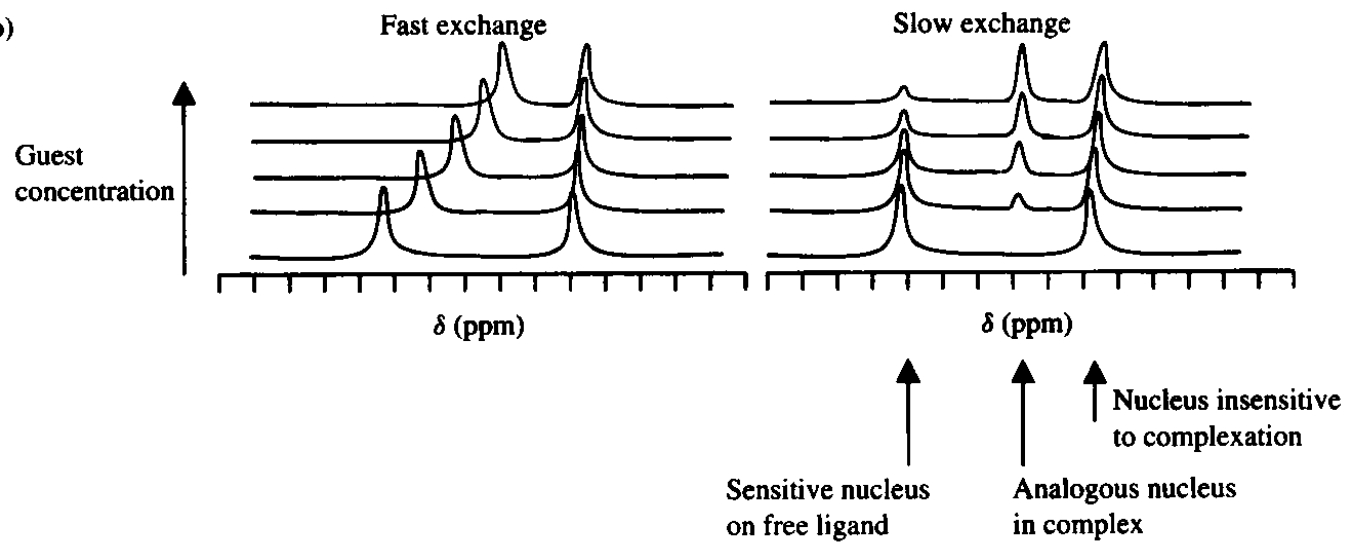


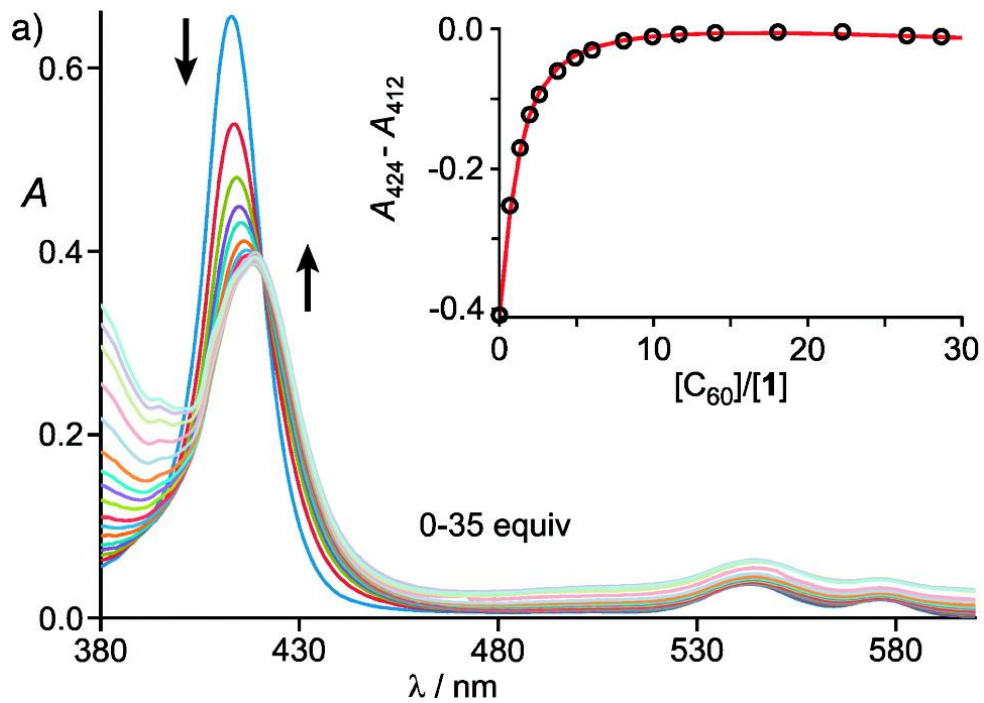
- NMR :  $[i] \approx \text{mM}$ ,  $K_{\text{max}} \approx 10^4$
- Microcalorimetry :  $[i] \approx \text{mM}$ ,  $K_{\text{max}} \approx 10^7$
- UV-vis :  $0.01 \text{ mM} < [i] < \text{mM}$ ,  $K_{\text{max}} \approx 10^6$
- Fluorimetry :  $[i] \approx \mu\text{M}$ ,  $K_{\text{max}} \approx 10^8$

(a)

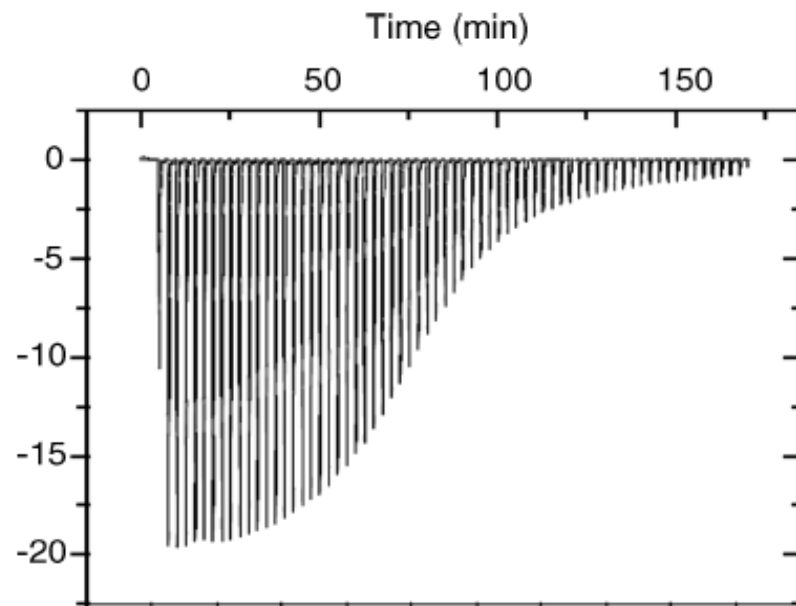


(b)

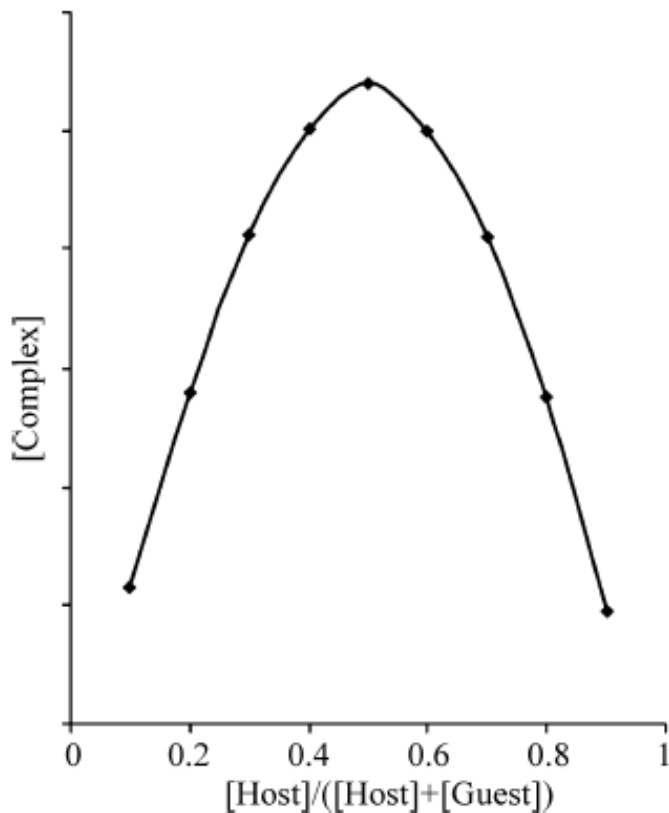




## Isothermal Calorimetry (ITC)







The total molar concentration of the two binding partners are held constant, but their mole fractions are varied.

An observable that is proportional to complex formation is plotted against the mole fractions of these two components.

The maximum on the plot corresponds to the **stoichiometry** of the two species.