

Duct systems

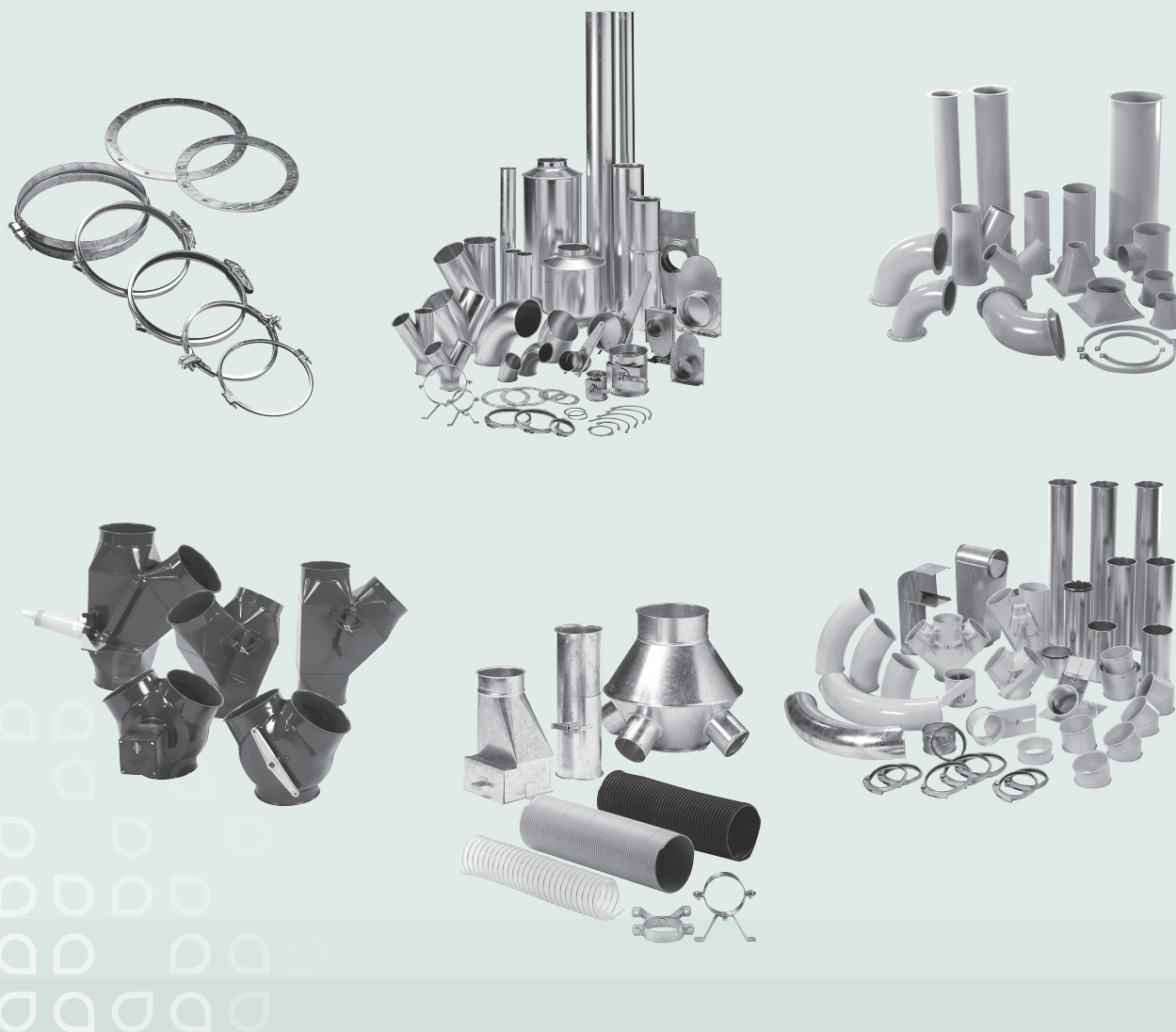

Kongskilde duct systems product programme

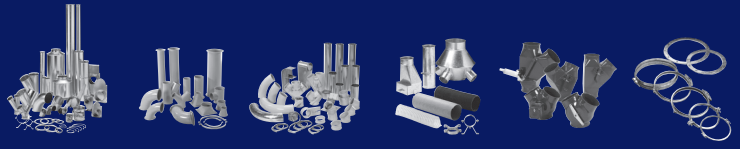

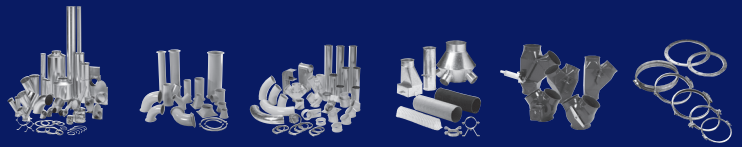

Table of contents

Section 00. General

Table of contents.....	Page 03
Kongskilde duct systems	Page 04 - 05
Assembly methods, galvanised duct systems.....	Page 06
Assembly methods, 2 and 3 mm duct systems.....	Page 07

Section 01. Galvanised duct systems

Laser welded and longitudinally lock formed ducts, galv.....	Page 08
Telescopic ducts, galvanised.....	Page 09
Ducts with access door, galvanised	Page 10
Ducts with cleaning spigot, galvanised.....	Page 11
Pressed bends, galvanised	Page 12
Segment bends, galvanised	Page 13
30° straight branch pieces, galvanised	Page 14
45° straight branch pieces, galvanised	Page 15
30° conical branch pieces, galvanised.....	Page 16
45° conical branch pieces, galvanised.....	Page 17
30° branch plates, galvanised	Page 18
45° branch plates, galvanised	Page 19
30° and 45° trouser pieces, galvanised	Page 20
90° T-pieces, galvanised	Page 21
Tapers, galvanised.....	Page 22
Transition pieces, galvanised.....	Page 23

Section 02. 2 and 3 mm duct systems

Ducts, 2 and 3 mm	Pages 24-25
Telescopic ducts, 2 mm	Page 26
Ducts with direct flange, 2 and 3 mm	Page 27
Welding ends, 2 and 3 mm	Page 28
Pressed bends, 2 and 3 mm	Page 29
Segment bends, 2 and 3 mm	Page 30
30° straight branch pieces, 2 and 3 mm	Page 31
45° straight branch pieces, 2 and 3 mm	Page 32
30° conical branch pieces, 2 and 3 mm	Page 33
45° conical branch pieces, 2 and 3 mm	Page 34
30° trouser pieces, 2 and 3 mm	Page 35
90° T-pieces, 2 and 3 mm	Page 36
Tapers, 2 and 3 mm	Pages 37- 38
Transition pieces, 2 and 3 mm.....	Page 39

Section 04. Sliding dampers, throttle valves, diverters

Automation for sliding dampers, throttle valves and diverters.....	Page 40
Tight sliding dampers, ø80 - ø200 mm, galv., manual, pneumatic	Page 41

Section 04. Sliding dampers, throttle valves, diverters

Tight sliding dampers, ø225 - ø550 mm, galv., manual, pneumatic	Page 42
Sliding dampers, ø80 - ø500 mm, galv., manual.	Page 43
Sliding dampers, ø80 - ø500 mm, galv., pneumatic, electric	Page 44
Throttle valves, ø80 - ø160 mm, galv., manual, pneumatic, electric.....	Page 45
Throttle valves, ø180 - ø500 mm, galv., manual, pneumatic, electric.....	Page 46
60° branch diverters, pressed, manual, pneumatic, electric.....	Page 47
45° branch diverters, pressed, manual	Page 48
45° branch diverters, welded, manual, pneumatic, electric.....	Page 49
60° trouser diverters, pressed, manual, pneumatic, electric.....	Page 50
60° trouser diverters, welded, manual, pneumatic, electric.....	Page 51

Section 05. Pull rings

Pull rings, galvanised	Page 52
Rubber gasket rings	Page 53

Section 06. Rapid lock pull rings

Rapid lock pull rings, galvanised	Page 54
---	---------

Section 07. Flanges

Flanges	Page 55
Rubber flanges.....	Page 56

Section 08. Caps

Jet caps, galvanised	Pages 57 - 58
Rain caps, galvanised.....	Page 59

Section 09. Accessories

Clip bands, galvanised	Page 60
Clip bands, primed, heavy design	Page 61
Cutting screens, galvanised	Page 62
Sweep ups, galvanised	Page 63

Section 10. Appendix

Appendix 1	Page 64
------------------	---------

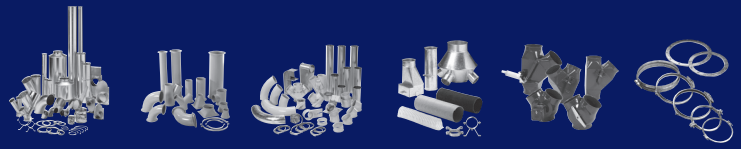

Kongskilde Duct Systems

Technical catalogue: Duct systems
 Section: 00
 Page: 2/5
 Revised: 01.05.2009

Kongskilde's programme includes galvanised duct systems and welded duct systems in 2 and 3 mm material thickness, and thus represent the basic element in extraction and transport of particles and air.

Kongskilde's duct systems have a circular cross section, with a wide range of ducts, bends, trouser-, branch-, end-, transition and taper pieces, throttle valves, diverters, jet- and rain caps etc. to ensure individual adaptation and a high degree of flexibility.

This catalogue covers Kongskilde's standard components for the following dimensions: $\varnothing 80 - \varnothing 1000$ mm.

Special customised components are available to order.

Galvanised duct system

The galvanised duct system includes all components necessary for a complete and flexible extraction solution and can be used for particle transport, welding extraction etc.

- laser welded ducts
- longitudinally lock formed ducts
- pressed bends
- tight sliding dampers
- branch- and trouser pieces
- throttle valves
- adapters

$\varnothing 80 - \varnothing 400$ mm ducts are laser welded. Other sizes are longitudinally lock formed ducts. Bends, branch pieces, shaped pieces etc are assembled with overlap and point-welded.

Ducts and shaped pieces are manufactured from hot dip galvanised steel sheet: Dogal 280, DX 51 D, DX 54 D or DX 56 D with material thickness from 0.75 mm – 1.25 mm.

Surface treatment class is Z 275 - i.e. zinc coating is minimum 275 g/m² double sided.

Pull rings [f.b] are used as standard joint assembly for rapid assembly and separation on $\varnothing 80$ mm to $\varnothing 800$ mm ducts, and loose flanges [f.b.m.fl] are used for $\varnothing 850$ mm to $\varnothing 1000$ mm ducts.

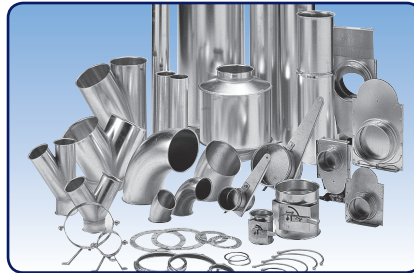

Laser welded and longitudinally lock formed duct system, galvanised

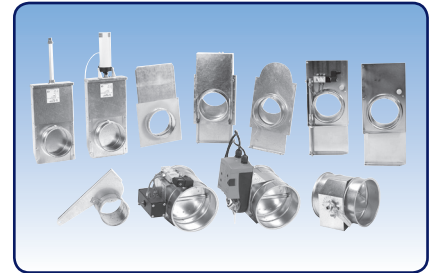

Sliding dampers, throttle valves

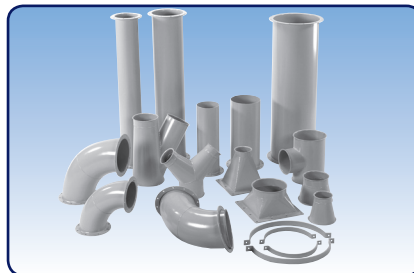

2 and 3 mm duct system

Diverters

2 and 3 mm duct system

The 2 and 3 mm system includes all components necessary for a complete and flexible extraction solution and can be used for particle transport, welding extraction etc.

- laser welded ducts
- plasma welded ducts
- pressed bends
- tight sliding dampers
- branch- and trouser pieces
- throttle valves
- diverters – pressed and welded
- adapters

The heavy duty sheet thickness means that this system is ideal for applications using high pressure or highly abrasive particles.

$\varnothing 80 - \varnothing 400$ mm ducts are laser welded. Other sizes are plasma welded. Bends, diverters, branch- and trouser pieces, shaped pieces etc are fully welded. Ducts and shaped pieces are made of DC 01 or DOMEX 240 sheet metal with a thickness of 2 – 3 mm.

Pull rings [f.b] are used as standard joint assembly for rapid assembly and separation on $\varnothing 80$ mm to $\varnothing 600$ mm ducts, and loose flanges [m.fl] are used for $\varnothing 650$ mm to $\varnothing 1000$ mm ducts.

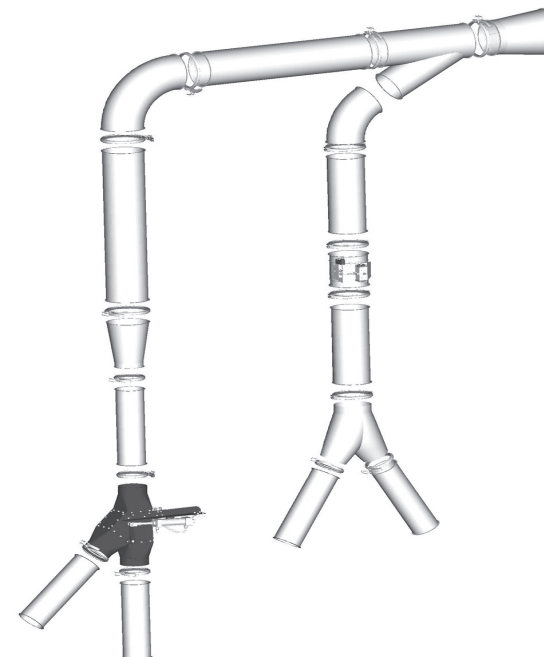

The duct system can be supplied with no surface treatment, powder coated primed (RAL 7032), or powder coated with zinc primer and top coat paint. Standard colour is RAL 5010, but other colours and hot dip/electro-galvanised

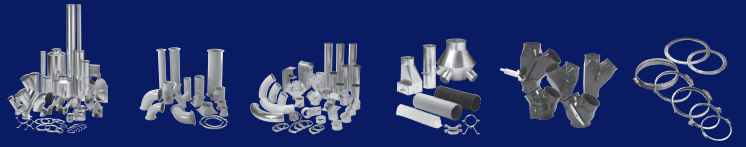

Kongskilde Duct Systems

Technical catalogue: Duct systems
 Section: 00
 Page: 3/5
 Revised: 01.05.2009

finishes are available at an additional price.

Surface treatment

Kongskilde has installed a state-of-the-art automatic 3-zone powder coating plant, which ensures high, uniform quality on all painted items.

Benefits of powder coating:

- High quality, impact and scratch-resistant surface
- High material usage – no evaporation
- Environment protection - no solvents

Primed duct systems fulfil corrosion class C2, cf. ISO 12944 and have received the following surface treatment:

1. Cleaning and iron phosphate finish at 50-55°C
2. Rinsed in water at 20-35°C

3. Rinsed with demineralised water at 15-30°C
 4. Dried at 120-130°C
 5. Robot-applied zinc epoxy-primer; layer thickness: 60-80 my
 6. Primer hardening at 180-190°C.
- Components with welded flanges are sandblasted to SA 2.5 before application of the above.

Duct systems can also be supplied painted (standard colour RAL 5010), with the before mentioned surface treatment but with a layer thickness of 80-120 my. If a higher corrosion class is required, please specify when ordering. Kongskilde can supply products which fulfil up to corrosion class C4, cf. ISO 12944.

Temperature range

Both duct systems can be used as standard at temperatures from -30°C to 80°C. Higher temperature tolerance available to order.

Tightness

Leaks in a duct system mean loss of capacity and undesirable noise. The Kongskilde duct systems are manufactured with minor tolerances, to ensure tight joints. Use of pull rings or rapid lock pull rings ensures that the duct section fulfills tightness class

C, the best tightness class within industrial extraction. Joint sealing compound or rubber flanges (EPDM) are recommended for flange assemblies to ensure tight joints. Correct assembly with sealing compound will result in assemblies which fulfil the requirements for tightness class C. See appendix 1 page 69.

Quality assurance

Kongskilde's quality assurance system is certified according to DS/ISO9001 (DS/EN29001).



Jet- and rain caps



Pull rings, rapid lock pull rings, flanges



Accessories: Sanding tables, clip bands etc.

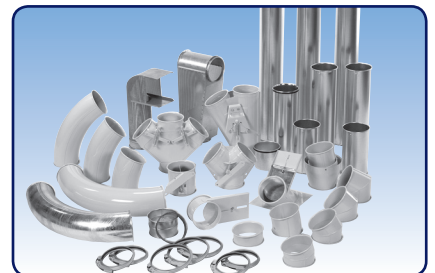

JK-6" duct system

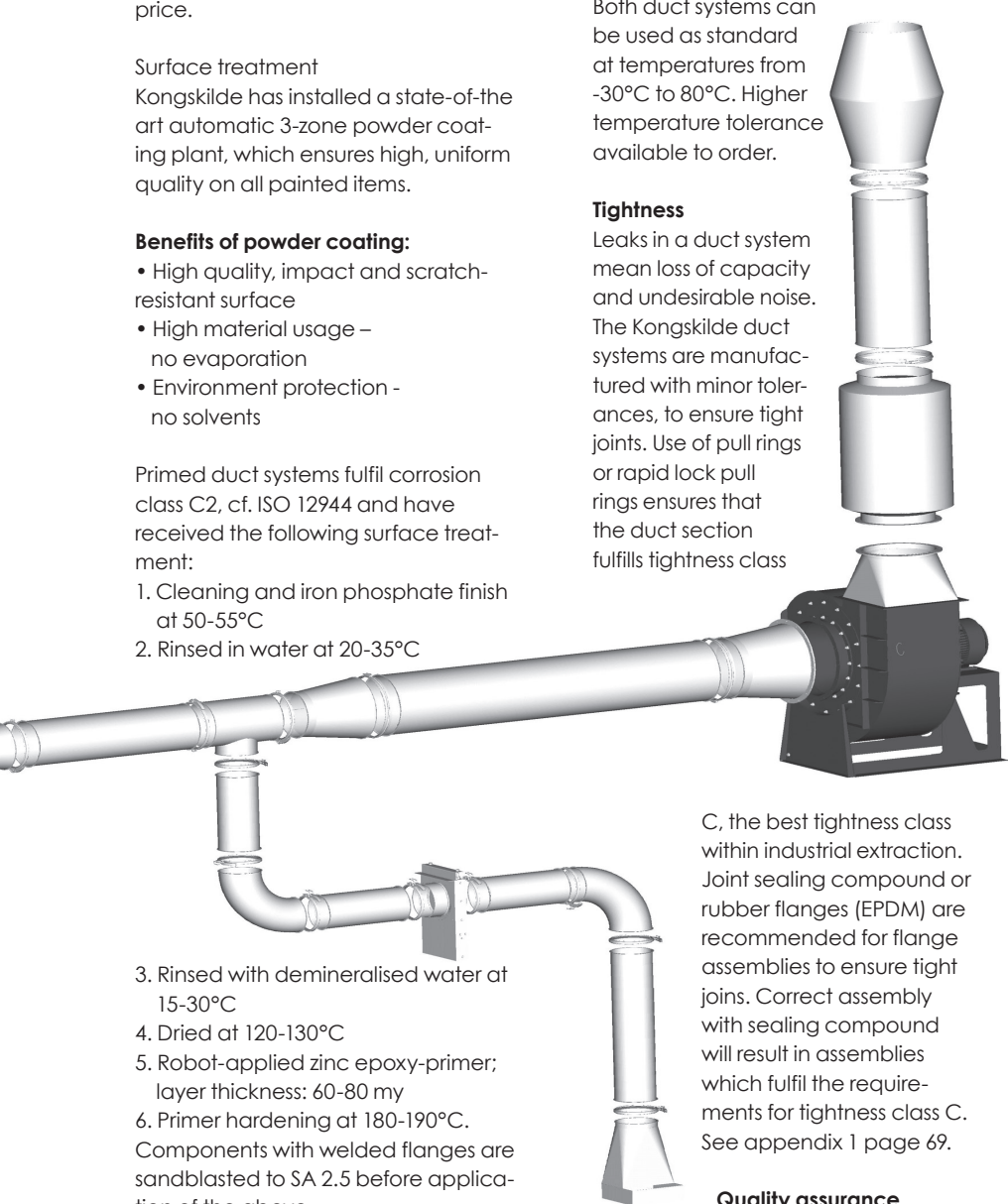

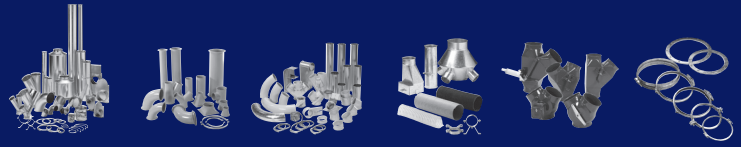

Assembly methods, galvanised duct systems

Technical catalogue: Duct systems
 Section: 00
 Page: 4/5
 Revised: 01.05.2009

Assembly methods

The high, uniform quality of Kongskilde's duct systems along with efficient assembly and sealing ensures quick and easy assembly, with the ability to perform subsequent modifications.

The components for the galvanised duct system are made for a range of different assembly methods, which are also suitable for other systems.

Galvanised duct systems can be supplied to order for assembly with:

- pull rings [f.b]: $\varnothing 80 - \varnothing 500$ mm
- wide pull rings [f.bb]: $\varnothing 150 - \varnothing 750$ mm
- rapid lock pull rings with handle [f.lyn]: $\varnothing 80 - \varnothing 400$ mm
- rapid lock pull rings with bolt [f.lyn]: $\varnothing 450 - \varnothing 600$ mm
- loose flanges [f.b.m.fl]: $\varnothing 80 - \varnothing 1000$ mm
- hoses [f.sl]: $\varnothing 80 - \varnothing 400$ mm
- smooth [gl]: $\varnothing 80 - \varnothing 1000$ mm

The assembly method depends on duct dimensions, strength, tightness, noise and installation requirements.

Tightness can be increased when using $\varnothing 80 - \varnothing 300$ mm pull rings by fitting a U-shaped rubber gasket ring (EPDM) on the f.b. edge. Rapid lock pull rings have a fixed liner (EPDM), which ensures an airtight joint.

Assembly method must be stated when placing order. Assembly methods are stated under the illustrations.

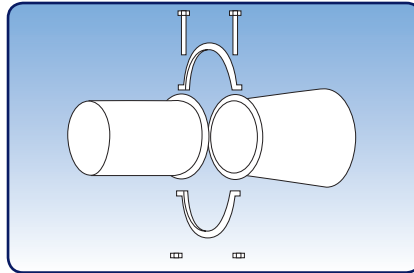

For pull rings [f.b]

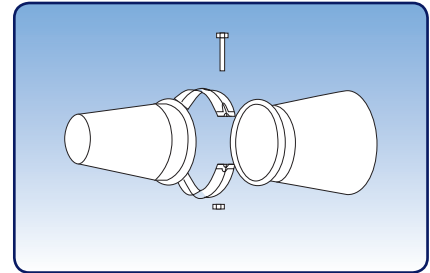

For wide pull rings [f.bb]

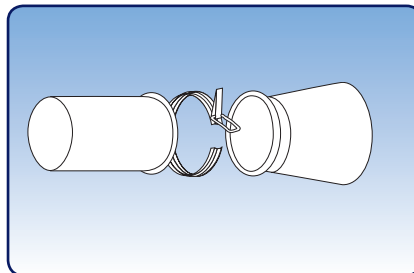

For rapid lock pull rings [f.lyn]

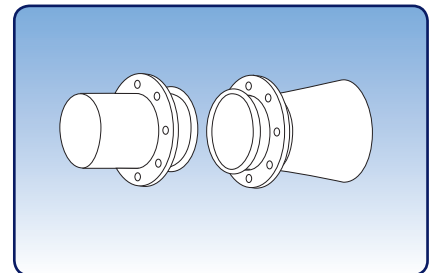

With loose flange fitted [f.b.m.fl]

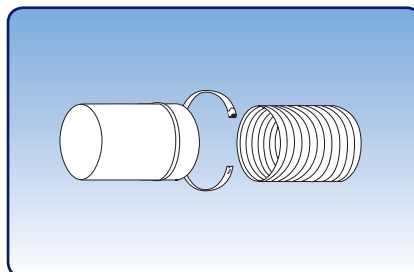

For hoses [f.sl]

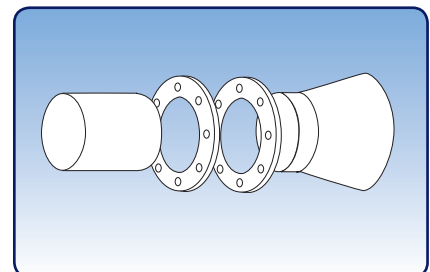

For flanges [f.fl]

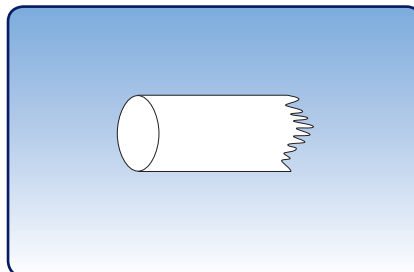

Smooth [gl]

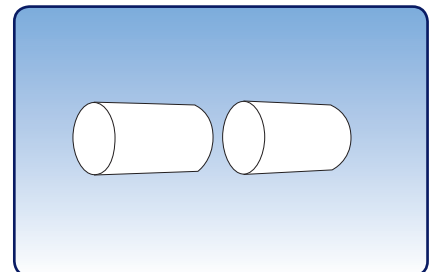

Conical [k]

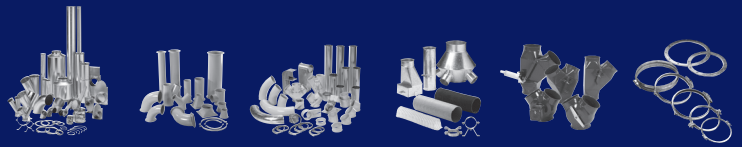

Assembly methods, 2 and 3 mm duct systems

Technical catalogue: Duct systems
 Section: 00
 Page: 5/5
 Revised: 01.05.2009

Assembly methods

The high, uniform quality of Kongskilde's duct systems along with efficient assembly and sealing ensures quick and easy assembly, with the ability to perform subsequent modifications.

The components for 2 and 3 mm duct system are made for a range of different assembly methods, which are also suitable for other systems. 2-3 mm duct systems can be supplied to order for assembly with:

- 2 and 3 mm pull rings [f.b]:
 $\varnothing 80 - \varnothing 600$ mm
- rapid lock pull rings with handle [f.lyn]:
 $\varnothing 80 - \varnothing 400$ mm
- rapid lock pull rings with bolt [f.lyn]:
 $\varnothing 450 - \varnothing 600$ mm
- loose flanges [f.b.m.fl]: $\varnothing 80 - \varnothing 600$ mm
- welded flanges [m.fl]: $\varnothing 80 - \varnothing 1000$ mm
- direct flanges [d.fl]: $\varnothing 300 - \varnothing 1000$ mm

The assembly method depends on duct dimensions, strength, tightness, noise and installation requirements.

Tightness can be increased when using $\varnothing 80 - \varnothing 300$ mm pull rings by fitting a U-shaped rubber gasket ring (EPDM) on the f.b. edge. $\varnothing 315 - \varnothing 600$ mm pull rings can be supplied with integral seal at an additional price. Rapid lock pull rings have a fixed liner (EPDM), which ensures an airtight join.

Ducts with rapid lock pull rings, loose flanges or direct flanges assembly methods are fitted with a straight duct-shaped end piece with a length of min. 50 mm.

Assembly method must be stated when placing order. Assembly methods are stated under the illustrations.

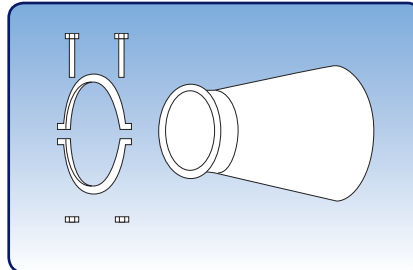

For pull rings [f.b]

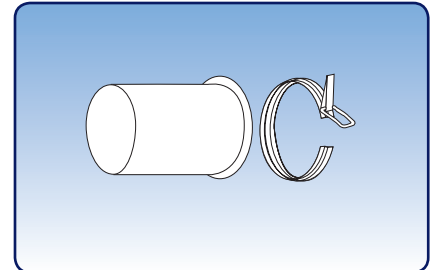

For rapid lock pull rings [f.lyn]

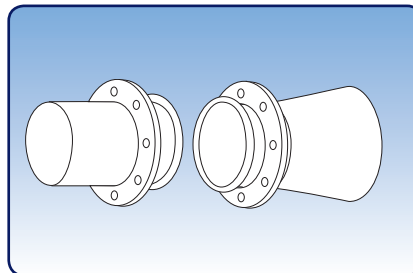

With loose flange fitted [f.b.m.fl]
 To max. $\varnothing 600$ mm diameter in 2.00 mm

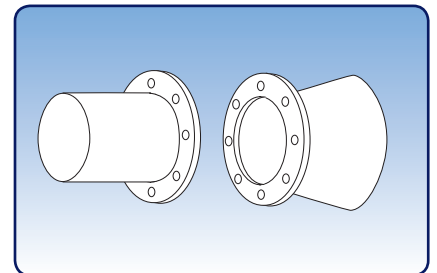

With welded flanges [m.fl]

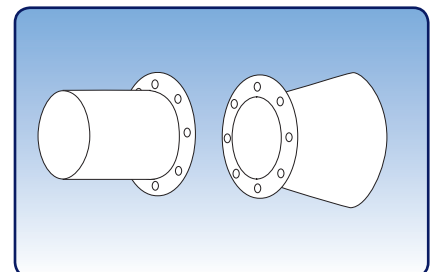

With direct flanges [d.fl]

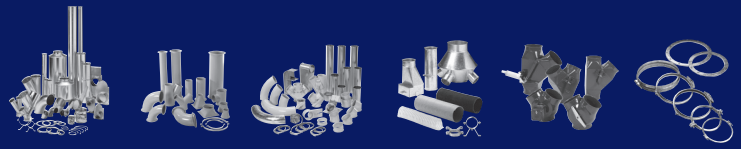

Laser welded and longitudinally lock formed ducts, galvanised

Technical catalogue: Duct systems
 Section: 01
 Page: 1/16
 Revised: 01.05.2009

Diameter: $\varnothing 80 - \varnothing 1000$ mm.

Laser welded and longitudinally lock formed ducts are galvanised and made from 0.75 mm, 0.90 mm or 1.00 mm sheet metal (s). Ducts are also available in 1.25 mm sheet metal.

Also available in other qualities and dimensions to order.

Ducts of up to $\varnothing 400$ mm diameter are supplied as standard laser welded in lengths of 0.5 m, 1.0 m and 2.0 m. Other sizes from $\varnothing 450$ mm diameter are supplied as longitudinally lock formed ducts in standard lengths of 0.5 m, 1.0 m and 2.0 m.

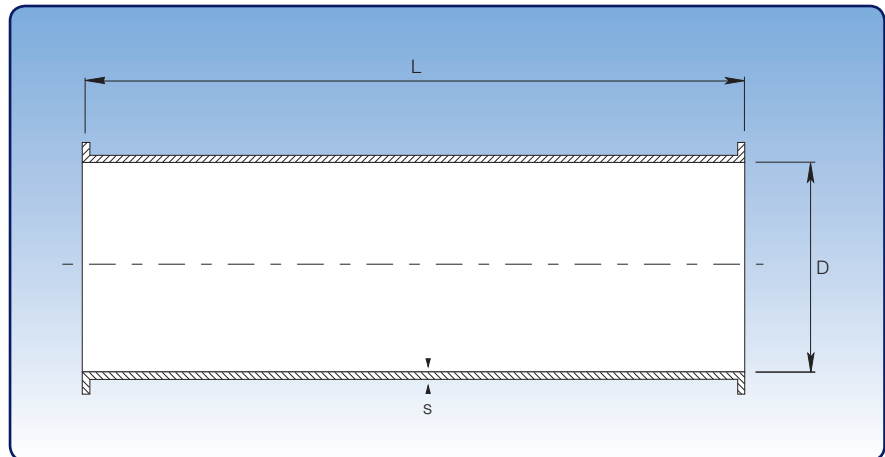

Dimensional specifications are given in the table below.

Dimensions							
D mm	s mm	Item no. L = 0.5 m	Weight at L = 0.5 m kg	Item no. L = 1.0 m	Weight at L = 1.0 m kg	Item no. L = 2.0 m	Weight at L = 2.0 m kg
Laser welded ducts							
80	0,75	92510701091	0,80	92510701191	1,60	92510701291	2,90
100	0,75	92510711091	1,00	92510711191	2,00	92510711291	3,70
120	0,75	92510721091	1,20	92510721191	2,40	92510721291	4,40
125	0,75	92510731091	1,25	92510731191	2,50	92510731291	4,60
140	0,75	92510741091	1,40	92510741191	2,80	92510741291	5,10
150	0,75	92510751091	1,50	92510751191	3,00	92510751291	5,50
160	0,75	92510761091	1,60	92510761191	3,20	92510761291	5,80
180	0,75	92510771091	1,75	92510771191	3,50	92510771291	6,70
200	0,75	92510781091	2,00	92510781191	4,00	92510781291	7,20
225	0,75	92510791091	2,25	92510791191	4,50	92510791291	8,20
250	0,75	92510801091	2,50	92510801191	5,00	92510801291	9,00
275	0,75	925108010199	2,75	925108011199	5,50	925108012199	11,00
300	0,75	92510811091	2,85	92510811191	5,70	92510811291	11,00
315	0,75	92510821091	3,00	92510821191	6,00	92510821291	12,00
350	0,75	92510831091	3,25	92510831191	6,50	92510831291	13,00
375	0,75	92510839091	3,25	92510839191	6,50	92510839291	13,00
400	0,90	92510841091	4,50	92510841191	9,00	92510841291	18,00
Longitudinally lock formed ducts							
450	0,90	9251085101	5,15	9251085111	10,30	9251085121	20,60
475	0,90	9251085901	5,43	9251085911	10,85	9251085921	21,70
500	0,90	9251086101	5,70	9251086111	11,40	9251086121	22,80
550	0,90	9251087101	6,25	9251087111	12,50	9251087121	25,00
600	0,90	9251088101	6,80	9251088111	13,60	9251088121	27,20
630	0,90	9251089101	7,20	9251089111	14,40	9251089121	28,80
650	0,90	9251090101	7,50	9251090111	15,00	9251090121	30,00
700	0,90	9251091101	8,00	9251091111	16,00	9251091121	32,00
750	0,90	9251092101	8,50	9251092111	17,00	9251092121	34,00
800	1,00	9251093101	10,00	9251093111	20,00	9251093121	40,00
850	1,00	9251094105	22,20	9251094115	32,95	9251094125	54,45
900	1,00	9251095105	23,60	9251095115	35,10	9251095125	48,10
950	1,00	9251096105	24,99	9251096115	37,24	9251096125	61,74
1000	1,00	9251097105	26,38	9251097115	39,38	9251097125	65,38

Item numbers designated with $D \leq 800$ mm are for ducts assembled with pull rings [f.b]. Item numbers designated $D \geq 850$ mm are for ducts with loose flanges [f.b.m.fl].

Ducts are also available for other assembly methods. See p. 6 for assembly methods.

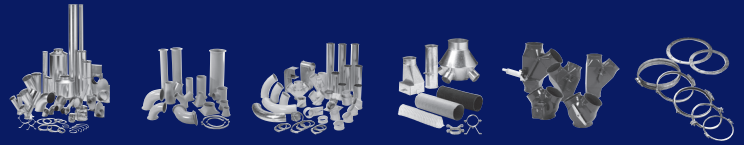

Telescopic ducts, galvanised

Technical catalogue: Duct systems
 Section: 01
 Page: 2/16
 Revised: 01.05.2009

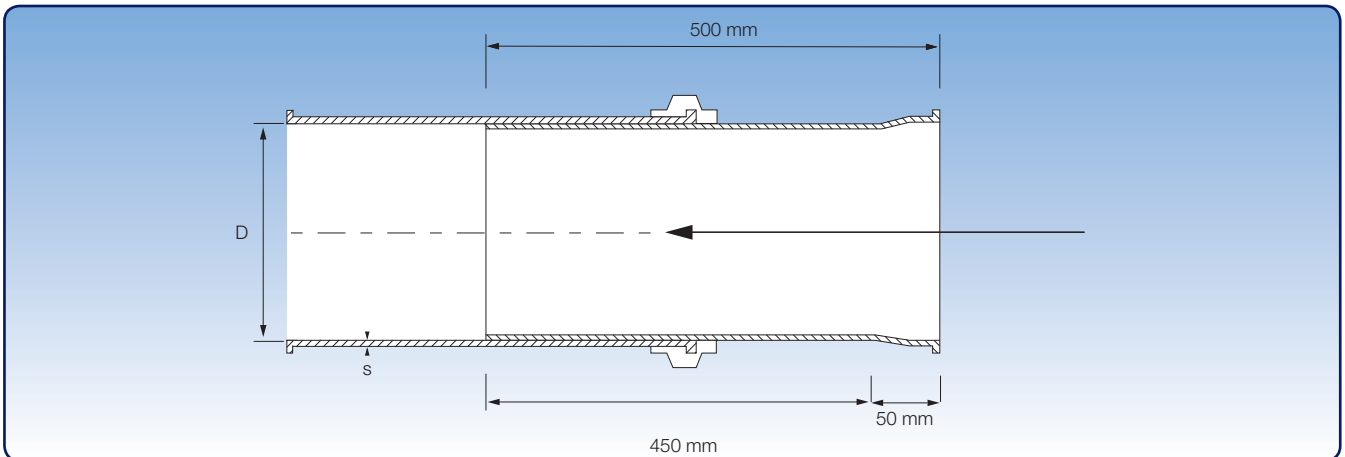

Dimensional specifications are given in the table below.

Diameter: $\varnothing 80 - \varnothing 500$ mm.

Telescopic ducts are made from 0.75 mm and 0.90 mm galvanised sheet metal and supplied with rapid lock pull rings, incl. rubber seal.

Item no.	Dimensions		Weight kg
	D mm	s mm	
9251099389	80	0,75	0,99
9251099394	100	0,75	1,20
9251099401	120	0,75	1,39
9251099411	125	0,75	1,45
9251099421	140	0,75	1,60
9251099431	150	0,75	1,70
9251099441	160	0,75	1,80
9251099451	180	0,75	2,07
9251099461	200	0,75	2,29
9251099471	225	0,75	2,53
9251099481	250	0,75	2,78
9251099491	275	0,75	3,07
9251099501	300	0,75	3,37
9251099511	315	0,75	3,58
9251099521	350	0,75	3,95
9251099531	400	0,90	5,00
9251099541	450	0,90	5,70
9251099551	500	0,90	6,30

The item numbers stated are for telescopic ducts assembled using pull rings [f.b].
 Telescopic ducts are also available for other assembly methods. See p. 6 for assembly methods.

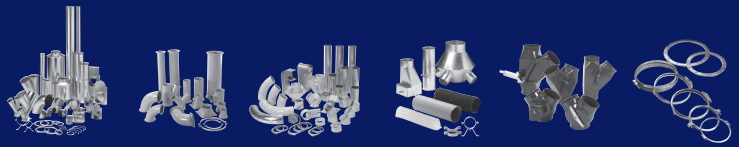

Ducts with access door, galvanised

Technical catalogue: Duct systems
 Section: 01
 Page: 3/16
 Revised: 01.05.2009

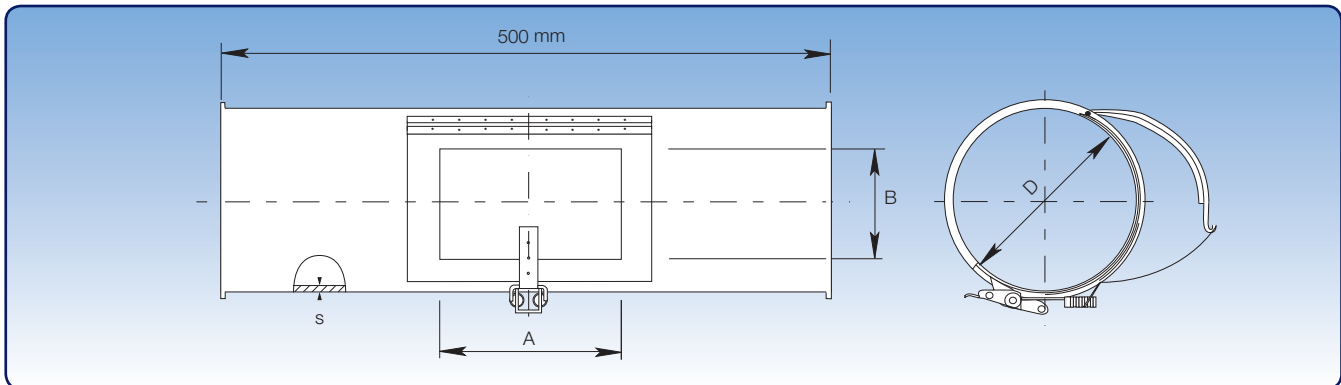

Dimensional specifications are given in the table below.

Diameter: $\varnothing 80 - \varnothing 1000$ mm.

Access doors are made of 1.25 mm galvanised sheet metal, such that the inside is smooth and has a close fit.

Item no.	Dimensions			Weight kg
	D mm	s mm	B × A mm	
9254670371	80	0,90	80 x 150	0,80
9254671371	100	0,90	100 x 150	1,00
9254672371	120	0,90	100 x 150	1,20
9254673371	125	0,90	100 x 150	1,25
9254674371	140	0,90	100 x 150	1,40
9254675371	150	0,90	100 x 150	1,50
9254676371	160	0,90	100 x 150	1,60
9254677371	180	0,90	100 x 150	1,75
9254678371	200	0,90	100 x 150	2,00
9254679371	225	0,90	100 x 150	2,25
9254680371	250	0,90	100 x 150	2,50
9254680379	275	0,90	100 x 150	2,65
9254681371	300	0,90	100 x 150	2,85
9254682371	315	0,90	100 x 150	3,00
9254683371	350	0,90	150 x 200	3,25
9254684371	400	0,90	150 x 200	4,50
9254685371	450	0,90	150 x 200	5,15
9254686371	500	0,90	150 x 200	5,70
9254687371	550	0,90	150 x 200	6,25
9254688371	600	0,90	150 x 200	6,80
9254689371	630	0,90	150 x 200	7,20
9254690371	650	0,90	150 x 200	7,50
9254691371	700	0,90	150 x 200	8,00
9254692371	750	0,90	150 x 200	8,50
9254693371	800	1,00	150 x 200	10,00
9254694371	850	1,00	150 x 200	10,75
9254695371	900	1,00	150 x 200	11,50
9254696371	950	1,00	150 x 200	12,25
9254697371	1000	1,00	150 x 200	13,00

Item numbers designated with $D \leq 800$ mm are for ducts assembled with pull rings [f.b.]. Item numbers designated $D \geq 850$ mm are for ducts with loose flanges [f.b.m.fl].

Ducts with access doors are also available for other assembly methods. See p. 6 for assembly methods.

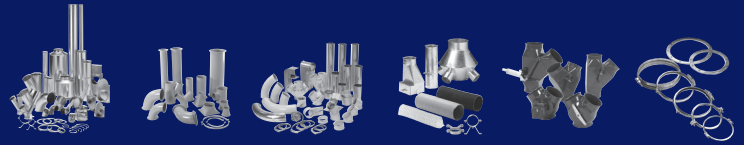

Ducts with cleaning spigot, galvanised

Technical catalogue: Duct systems
 Section: 01
 Page: 4/16
 Revised: 01.05.2009

Diameter: $\varnothing 100 - \varnothing 400$ mm.

The PVC cover is easy to fit and remove.
 All cleaning spigots have a $\varnothing 100$ mm opening.

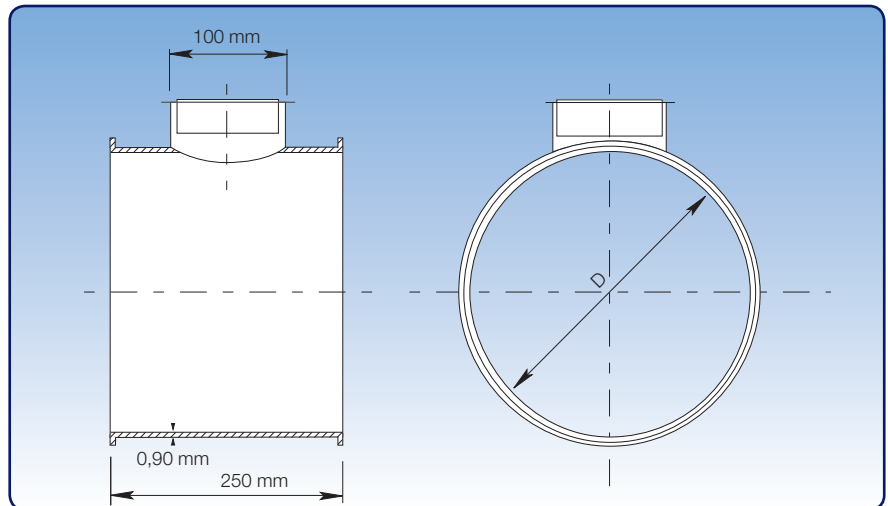

Dimensional specifications are given in the table below.

Item no.	Dimensions		Weight kg
	D mm		
9254671101	100		0,50
9254671102	120		0,60
9254671103	125		0,65
9254671104	140		0,70
9254671105	150		0,75
9254675101	160		0,80
9254675102	180		0,85
9254675103	200		1,00
9254675104	225		1,15
9254675105	250		1,25
9254675106	275		1,35
9254680101	300		1,45
9254680102	315		1,50
9254680103	350		1,65
9254680104	400		2,25

The item numbers stated are for ducts with cleaning spigots assembled using pull rings [f.b].
 Ducts with cleaning spigots are also available for other assembly methods. See p. 6 for assembly methods.

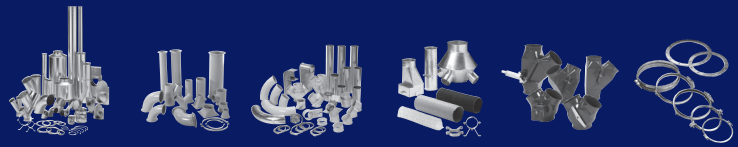

Pressed bends, galvanised

Technical catalogue: Duct systems
Section: 01
Page: 5/16
Revised: 01.05.2009

Diameter: $\varnothing 80 - \varnothing 400$ mm.

Galvanised bends are made of 1.00 mm sheet metal.

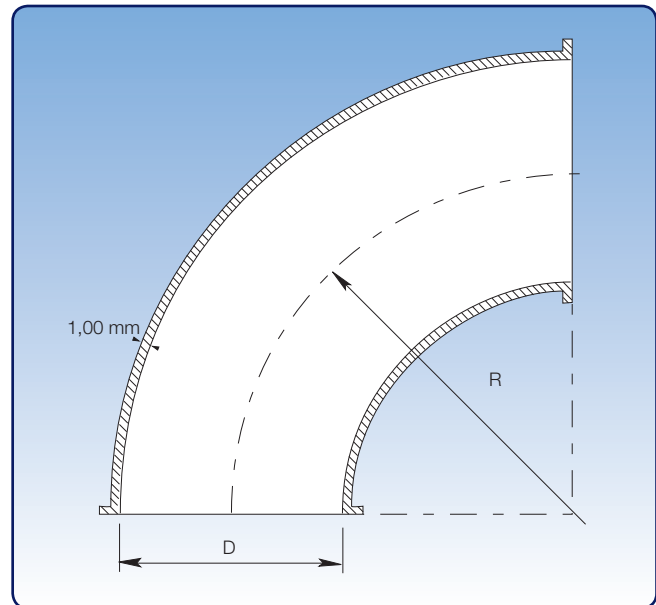

Dimensional specifications are given in the table below.
Diameter = (D). $R = 1.5 \times D$ for all dimensions.

D mm	Dimensions											
	90°		60°		45°		30°		15°		7.5°	
	Item no.	kg	Item no.	kg	Item no.	kg	Item no.	kg	Item no.	kg	Item no.	kg
80	9251170192	0,44	9251170162	0,24	9251170142	0,20	9251170132	0,12	9251170112	0,10	9251170102	0,10
100	9251171192	0,62	9251171162	0,40	9251171142	0,30	9251171132	0,20	9251171112	0,14	9251171102	0,13
120	9251172192	0,90	9251172162	0,60	9251172142	0,40	9251172132	0,30	9251172112	0,18	9251172102	0,16
125	9251173192	0,90	9251173162	0,65	9251173142	0,45	9251173132	0,32	9251173112	0,18	9251173102	0,18
140	9251174192	1,10	9251174162	0,80	9251174142	0,55	9251174132	0,40	9251174112	0,24	9251174102	0,20
150	9251175192	1,50	9251175162	0,90	9251175142	0,70	9251175132	0,50	9251175112	0,25	9251175102	0,20
160	9251176192	1,70	9251176162	1,10	9251176142	0,80	9251176132	0,50	9251176112	0,30	9251176102	0,29
180	9251177192	2,00	9251177162	1,30	9251177142	1,00	9251177132	0,70	9251177112	0,40	9251177102	0,30
200	9251178192	2,50	9251178162	1,85	9251178142	1,25	9251178132	1,00	9251178112	0,50	9251178102	0,35
225	9251179192	3,00	9251179162	2,00	9251179142	1,60	9251179132	1,20	9251179112	0,60	9251179102	0,37
250	9251180192	4,00	9251180162	3,00	9251180142	2,00	9251180132	1,50	9251180112	0,75	9251180102	0,50
275	92511801929	4,80	92511801629	3,60	92511801429	2,40	92511801329	1,80	92511801129	0,80	92511801029	0,55
300	9251181192	5,90	9251181162	3,90	9251181142	2,90	9251181132	2,00	9251181112	0,90	9251181102	0,60
315	9251182192	5,90	9251182162	3,80	9251182142	2,95	9251182132	2,00	9251182112	1,12	9251182102	0,55
350	9251183192	7,30	9251183162	4,80	9251183142	3,70	9251183132	2,55	9251183112	1,30	9251183102	1,00
400	9251184192	10,20	9251184162	6,70	9251184142	5,10	9251184132	3,60	9251184112	1,60	9251184102	1,20

The item numbers stated are for bends assembled using pull rings [f.b.].
Bends are also available for other assembly methods. See p. 6 for assembly methods.

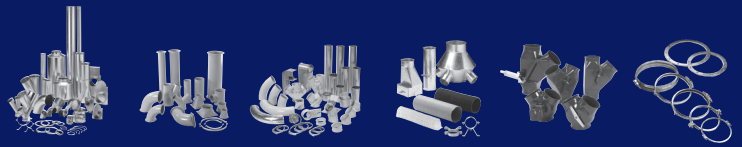

Segment bends, galvanised

Technical catalogue: Duct systems
 Section: 01
 Page: 6/16
 Revised: 01.05.2009

Diameter: $\varnothing 450 - \varnothing 1000$ mm.

Galvanised segment bends are made from 0.90 mm and 1.00 mm sheet metal (s).

They are available in other radii and dimensions to order.

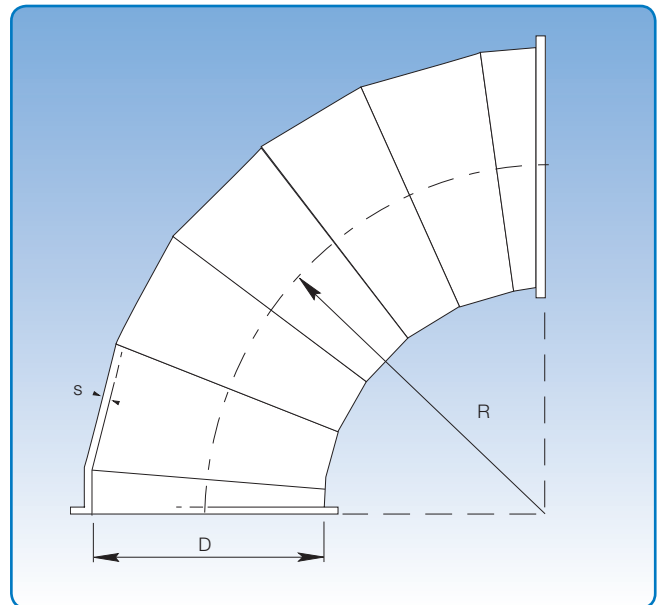

Dimensional specifications are given in the table below.
 $R = 1.5 \times D$ for all dimensions.

Dimensions													
D mm	s mm	90°		60°		45°		30°		15°		7.5°	
		Item no.	kg	Item no.	kg	Item no.	kg	Item no.	kg	Item no.	kg	Item no.	kg
450	0,90	9251185792	12,00	9251185762	9,00	9251185742	6,00	9251185732	4,50	9251185712	2,25	9251185702	1,10
500	0,90	9251186792	15,00	9251186762	11,20	9251186742	7,50	9251186732	5,60	9251186712	2,80	9251186702	1,40
550	0,90	9251187792	18,00	9251187762	13,50	9251187742	9,00	9251187732	6,80	9251187712	3,40	9251187702	1,70
600	0,90	9251188792	21,50	9251188762	16,10	9251188742	10,75	9251188732	8,05	9251188712	4,00	9251188702	2,00
630	0,90	9251189792	22,40	9251189762	16,80	9251189742	11,20	9251189732	8,40	9251189712	4,20	9251189702	2,10
650	0,90	9251190792	25,00	9251190762	18,80	9251190742	12,50	9251190732	9,40	9251190712	4,70	9251190702	2,35
700	0,90	9251191792	29,00	9251191762	21,80	9251191742	14,50	9251191732	10,90	9251191712	5,40	9251191702	2,70
750	0,90	9251192792	33,00	9251192762	24,80	9251192742	16,50	9251192732	12,40	9251192712	6,20	9251192702	3,10
800	1,00	9251193792	37,50	9251193762	28,10	9251193742	18,75	9251193732	14,05	9251193712	7,00	9251193702	3,50
850	1,00	9251194792	42,50	9251194762	32,00	9251194742	21,25	9251194732	16,00	9251194712	8,00	9251194702	4,00
900	1,00	9251195792	48,00	9251195762	36,00	9251195742	24,00	9251195732	18,00	9251195712	9,00	9251195702	4,50
950	1,00	9251196792	53,00	9251196762	39,80	9251196742	26,50	9251196732	20,00	9251196712	10,00	9251196702	5,00
1000	1,00	9251197792	59,00	9251197762	44,00	9251197742	29,50	9251197732	22,00	9251197712	11,00	9251197702	5,50

Item numbers designated $D \leq 800$ mm are for segment bends assembled using pull rings [f.b]. Item numbers designated $D \geq 850$ mm are for ducts with loose flanges [f.b.m.fl].

Segment bends are also available for other assembly methods. See p. 6 for assembly methods.

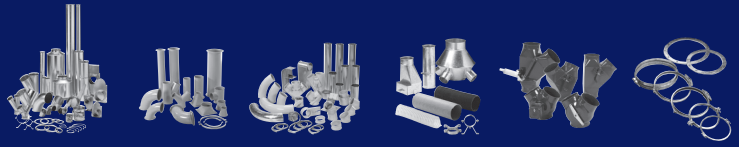

30° straight branch pieces, galvanised

Technical catalogue: Duct systems
 Section: 01
 Page: 7/16
 Revised: 01.05.2009

Diameter: ø80 – ø1000 mm.

Galvanised branch pieces are made of 0.90 mm sheet metal.

When assembled with loose flanges, [f.b.m.fl], L1 is extended by 2 x 50 mm.

State A-, B- and C dimensions when ordering. Options are limited by A = C, and A ≥ B. A = C must be max. 1000 mm.

The branch determines the length of L1. Branch pieces are always straight with the branch centrally located.

L1, L2 and L3 can be calculated using the stated formulas.

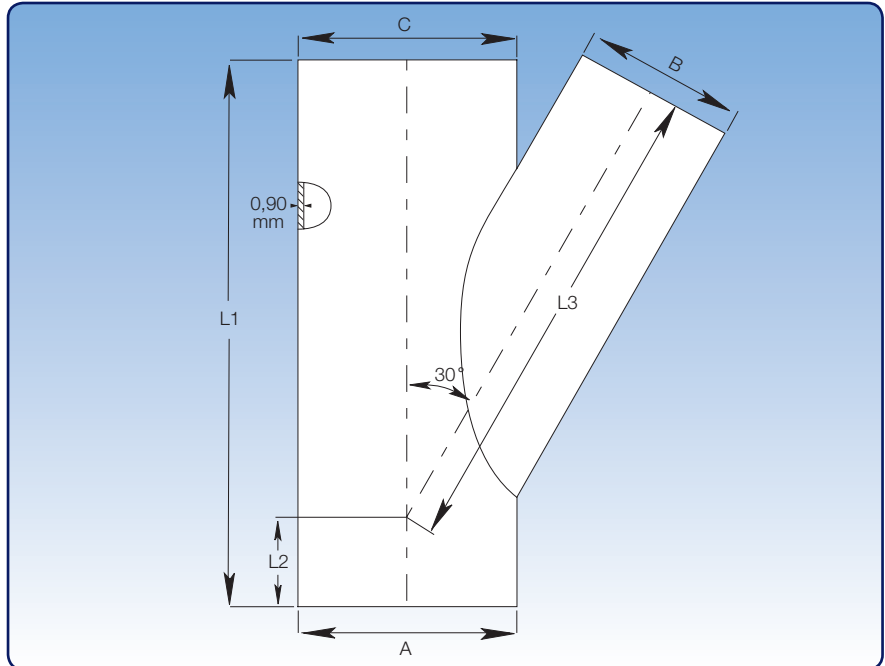

Calculating L2 and L3:

L1 = see table

$$L2 = \frac{1}{2} \times \left(L1 - \frac{A}{\tan \alpha} \right)$$

$$L3 = \frac{L1 - L2}{\cos \alpha} \left(- \frac{B}{2} \times \tan \alpha \right)$$

Example:

A = 650, B = 400, C = 650

L1 = 1050 mm

$$L2 = 0,5 \times \left(1050 - \frac{650}{\tan 29,7} \right) = 0,5 \times (1050 - 1139,57)$$

L2 = - 44,79 p - 45 mm

$$L3 = \frac{1050 + 45}{\cos 29,7} - \left(\frac{400}{2} \times \tan 29,7 \right) = 1260,60 - 114,08$$

L3 = 1146,52 p 1147 mm

Dimensions					
A = C mm	B mm	L1 mm	L2 mm	L3 mm	□
Select (80 - 1000)	80	350	Calculate	Calculate	28,0
	100	350			28,8
	120	350			28,8
	125	400			29,0
	140	450			29,1
	150	450			29,2
	160	450			29,2
	180	550			29,3
	200	550			29,3
	225	600			29,4
	250	750			29,5
	275	750			29,6
	300	750			29,6
	315	850			29,6
	350	950			29,6
	400	1050			29,7
	450	1250			29,7
	500	1250			29,7
	550	1450			29,8
	600	1450			29,8
630	1650	29,8			
650	1650	29,8			
700	1650	29,8			
750	1850	29,9			
800	1850	29,9			
850	2050	29,9			
900	2050	29,9			

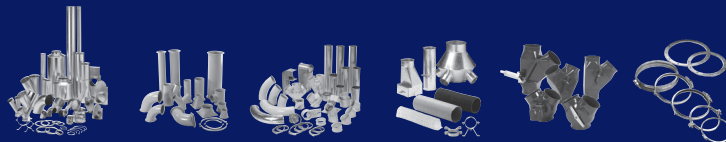

45° straight branch pieces, galvanised

Technical catalogue: Duct systems
 Section: 01
 Page: 8/16
 Revised: 01.05.2009

Diameter: ø80 – ø1000 mm.

Galvanised branch pieces are made of 0.90 mm sheet metal.

When supplied with loose flanges, [f.b.m.fl], L1 is extended by 2 x 50 mm.

State A-, B- and C dimensions when ordering. Options are limited by A = C, and A ≥ B. A = C must be max. 1000 mm.

The branch determines the length of L1. Branch pieces are always straight with the branch centrally located.

L1, L2 and L3 can be calculated using the stated formulas.

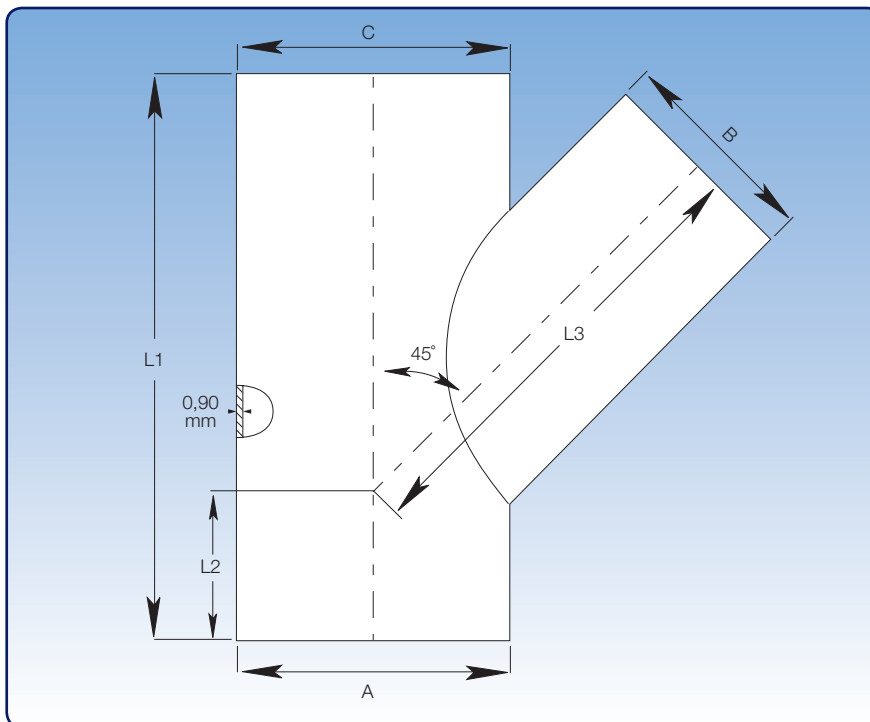

Calculating L2 and L3:

L1 = see table

$$L2 = \frac{1}{2} \times \left(1 - \frac{A}{\text{tg} \alpha} \right)$$

$$L3 = \frac{L1 - L2}{\cos \alpha} - \left(\frac{B}{2} \times \text{tg} \alpha \right)$$

Example:

A = 500, B = 450, C = 500

L1 = 950 mm

$$L2 = 0,5 \times \left(950 - \frac{500}{\text{tg} 44,7} \right) = 0,5 \times (950 - 505,26)$$

L2 = - 222,37 p - 222 mm

$$L3 = \frac{950 + -222}{\cos 44,7} - \left(\frac{450}{2} \times \text{tg} 44,7 \right) = 1024,19 - 222,66$$

L3 = 801,53 p 802 mm

Dimensions					
A = C mm	B mm	L1 mm	L2 mm	L3 mm	α
Select (80 - 1000)	80	300	Calculate	Calculate	43,8
	100	300			43,8
	120	350			44,0
	125	350			44,0
	140	350			44,1
	150	400			44,2
	160	400			44,2
	180	400			44,3
	200	450			44,4
	225	500			44,5
	250	500			44,5
	275	600			44,6
	300	600			44,6
	315	600			44,6
	350	700			44,7
	400	800			44,7
	450	950			44,7
	500	950			44,8
	550	1150			44,8
	600	1050			44,8
630	1150	44,8			
650	1150	44,8			
700	1300	44,8			
750	1300	44,8			
800	1450	44,9			
850	1450	44,9			
900	1650	44,9			

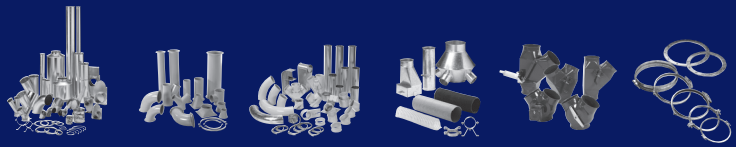

30° conical branch pieces, galvanised

Technical catalogue: Duct systems
 Section: 01
 Page: 9/16
 Revised: 01.05.2009

Diameter A: ø100 - ø1000 mm.

Galvanised branch pieces are made of 0.90 mm sheet metal.

L1 will be extended by 2 x 50 mm if the branch piece is supplied with loose flanges [f.b.m.fl], rapid lock pull rings [f.lyn] or wide pull rings [f.bb].

State branch piece A, B- and C dimensions when ordering. A, B and C can be combined to order; although branch B determines length L1 as stated in the table.

Maximum diameter reduction between A and C is 200 mm. For B applies: $B < (A+C)/2$.

The largest branch will determine L1 for double branch pieces.

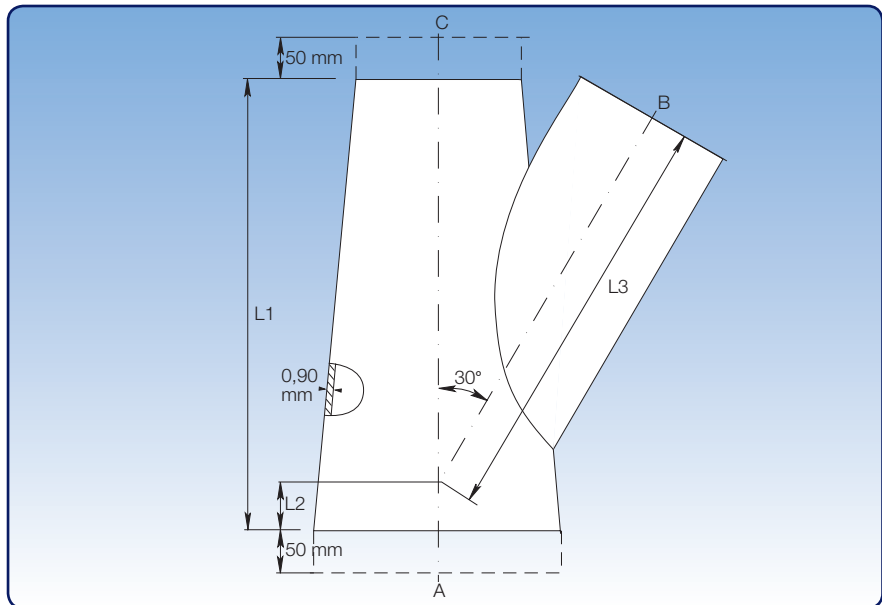

Calculating L2 and L3:

L1 = See table

$$L2 = \left(\frac{L1}{2} \right) - \left(\frac{A + C}{4 \times \tan \alpha} \right)$$

$$L3 = \left(\frac{L1 - L2}{\cos \alpha} \right) - \left(\frac{B}{2} \times \tan \alpha \right)$$

Example:

A = 650, B = 500, C = 450

L1 = 1250 mm

$$L2 = \frac{1250}{2} - \left(\frac{650 + 450}{4 \times \tan 29,7} \right) = 625 - 476,31$$

L2 = 142,87 p 143 mm

$$L3 = \frac{1250 - 143}{\cos 29,7} - \left(\frac{500}{2} \times \tan 29,7 \right) = 1274,42 - 142,60$$

L3 = 1131,82 p 1132 mm

Dimensions						
A mm	B mm	C mm	L1 mm	L2 mm	L3 mm	α
	80		350			28,0
	100		350			28,8
	120		350			28,8
	125		400			29,0
	140		450			29,1
	150		450			29,2
	160		450			29,2
	180		550			29,3
	200		550			29,3
	225		600			29,4
	250		750			29,5
	275		750			29,6
	300		750			29,6
	315		850			29,6
	350		950			29,6
	400		1050			29,7
	450		1250			29,7
	500		1250			29,7
	550		1250			29,8
	600		1450			29,8
	630		1650			29,8
	650		1650			29,8
	700		1650			29,8
	750		1850			29,9
	800		1850			29,9
	850		2050			29,9
	900		2050			29,9
Select (100 - 1000)		Select (100 - 1000)		Calculate	Calculate	

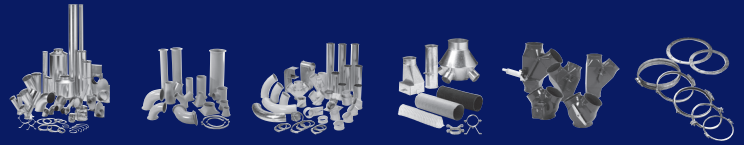

45° conical branch pieces, galvanised

Technical catalogue: Duct systems
 Section: 01
 Page: 10/16
 Revised: 01.05.2009

Diameter A: ø100 - ø1000 mm.

Galvanised branch pieces are made of 0.90 mm sheet metal.

L1 will be extended by 2 x 50 mm if the branch piece is supplied with loose flanges [f.b.m.fl], rapid lock pull rings [f.lyn] or wide pull rings [f.bb].

State branch piece A-, B- and C dimensions when ordering. A, B and C can be combined to order; although branch B determines length L1 as stated in the table.

Maximum diameter reduction between A and C is 200 mm. For B applies:
 $B < (A+C)/2$.

The largest branch will determine L1 for double branch pieces.

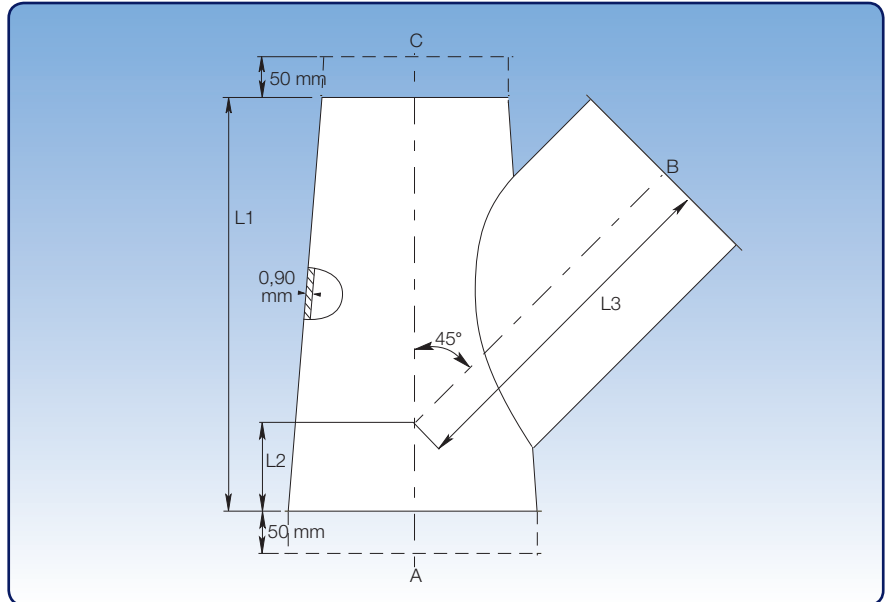

Calculating L2 and L3:

L1 = See table

$$L2 = \left(\frac{L1}{2} \right) - \left(\frac{A + C}{4 \times \text{tg} \alpha} \right)$$

$$L3 = \left(\frac{L1 - L2}{\cos \alpha} \right) - \left(\frac{B}{2} \times \text{tg} \alpha \right)$$

Example:

A = 500, B = 300, C = 350

L1 = 600 mm

$$L2 = \frac{600}{2} - \left(\frac{500 + 350}{4 \times \text{tg} 44,6} \right) = 300 - 215,49$$

L2 = 84,51 p 85 mm

$$L3 = \frac{600 - 85}{\cos 44,6} - \left(\frac{300}{2} \times \text{tg} 44,6 \right) = 723,29 - 149,92$$

L3 = 573,37 p 575 mm

Dimensions						
A mm	B mm	C mm	L1 mm	L2 mm	L3 mm	□
	80		300			43,8
	100		300			43,8
	120		350			44,0
	125		350			44,0
	140		350			44,1
	150		400			44,2
	160		400			44,2
	180		400			44,3
	200		450			44,4
Select (100 - 1000)	225	Select (100 - 1000)	500	Calculate	Calculate	44,5
	250		500			44,5
	275		600			44,6
	300		600			44,6
	315		600			44,6
	350		700			44,7
	400		800			44,7
	450		950			44,7
	500		1050			44,8
	550		1150			44,8
600	1150	44,8				
630	1150	44,8				
650	1150	44,8				
700	1300	44,8				
750	1300	44,8				
800	1450	44,9				
850	1450	44,9				
900	1650	44,9				

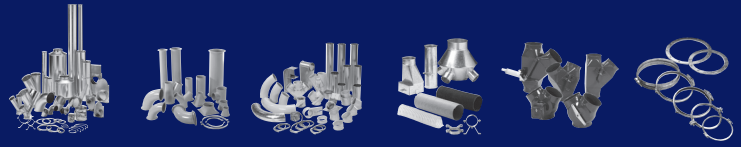

30° branch plates, galvanised

Technical catalogue: Duct systems
 Section: 01
 Page: 11/16
 Revised: 01.05.2009

Diameter: ø80 – ø1000 mm.

Galvanised branch plates are made of 0.90 mm sheet metal.

State A-, B- and C dimensions when ordering. Options are limited by A = C, and A ≥ B. A = C must be max. 1000 mm.

The branch determines the length of L1. Branch plates are always straight with the branch centrally located.

If B < 300: X = 50 mm
 If B > 300: X = 100 mm

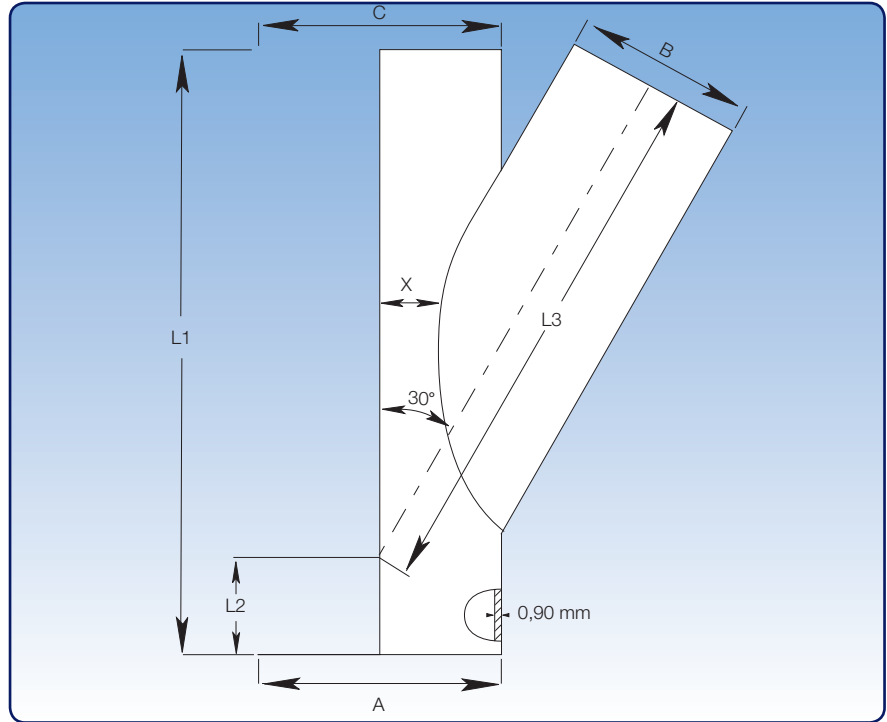

Calculating L2 and L3:

L1 = see table

$$L2 = \frac{1}{2} \times \left(L1 - \frac{A}{\tan \alpha} \right)$$

$$L3 = \frac{L1 - L2}{\cos \alpha} \times \left(\frac{B}{2} \times \tan \alpha \right)$$

Example:

A = 700, B = 350, C = 700

L1 = 950 mm

$$L2 = 0,5 \times \left(950 - \frac{700}{\tan 29,6} \right) = 0,5 \times (950 - 1232,22)$$

L2 = - 141,11 p - 141 mm

$$L3 = \frac{950 + 141}{\cos 29,6} \times \left(\frac{350}{2} \times \tan 29,6 \right) = 1254,75 - 99,41$$

L3 = 1155,34 p 1155 mm

Dimensions					
A = C mm	B mm	L1 mm	L2 mm	L3 mm	α
Select (80 - 1000)	80	350	Calculate	Calculate	28,0
	100	350			28,8
	120	350			28,8
	125	400			29,0
	140	450			29,1
	150	450			29,2
	160	450			29,2
	180	550			29,3
	200	550			29,3
	225	600			29,4
	250	750			29,5
	275	750			29,6
	300	750			29,6
	315	850			29,6
	350	950			29,6
	400	1050			29,7
	450	1250			29,7
	500	1250			29,7
	550	1450			29,8
	600	1450			29,8
650	1650	29,8			
700	1650	29,8			
750	1850	29,8			
800	1850	29,9			
850	2050	29,9			
900	2050	29,9			

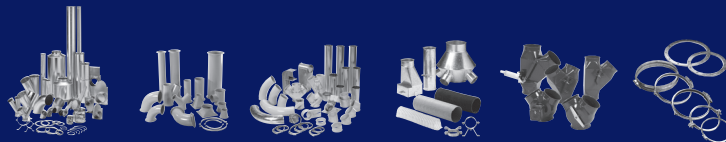

45° branch plates, galvanised

Technical catalogue: Duct systems
 Section: 01
 Page: 12/16
 Revised: 01.05.2009

Diameter: ø80 – ø1000 mm.

Galvanised branch plates are made of 0.90 mm sheet metal.

State A-, B- and C dimensions when ordering. Options are limited by $A = C$, and $A \geq B$. $A = C$ must be max. 1000 mm.

The branch determines the length of L1. Branch plates are always straight with the branch centrally located.

If $B < 300$: $X = 50$ mm
 If $B > 300$: $X = 100$ mm

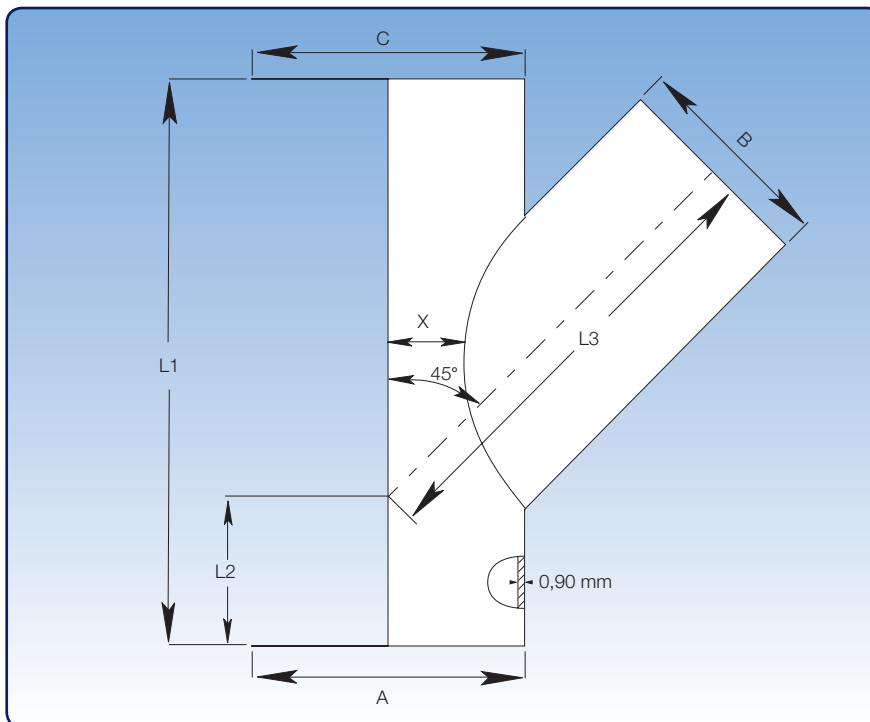

Calculating L2 and L3:

$L1 = \text{see table}$

$$L2 = \frac{1}{2} \times \left(L1 - \frac{A}{\tan \alpha} \right)$$

$$L3 = \frac{L1 - L2}{\cos \alpha} - \left(\frac{B}{2} \times \tan \alpha \right)$$

Example:

$A = 550, B = 500, C = 550$

$L1 = 1050$ mm

$$L2 = 0,5 \times \left(1050 - \frac{550}{\tan 44,8} \right) = 0,5 \times (1050 - 550)$$

$L2 = 248,07$ p 248 mm

$$L3 = \frac{1050 - 248}{\cos 44,8} - \left(\frac{500}{2} \times \tan 44,8 \right) = 1130,26 - 248,26$$

$L3 = 882$ mm

Dimensions					
A = C mm	B mm	L1 mm	L2 mm	L3 mm	α
Select (80 - 1000)	80	300	Calculate	Calculate	43,8
	100	300			43,8
	120	350			44,0
	125	350			44,0
	140	350			44,1
	150	400			44,2
	160	400			44,2
	180	400			44,3
	200	450			44,4
	225	500			44,5
	250	500			44,5
	275	600			44,6
	300	600			44,6
	315	600			44,6
	350	700			44,7
	400	800			44,7
	450	950			44,7
	500	1050			44,8
	550	1150			44,8
	600	1150			44,8
650	1150	44,8			
700	1300	44,8			
750	1300	44,8			
800	1450	44,8			
850	1450	44,9			
900	1650	44,9			

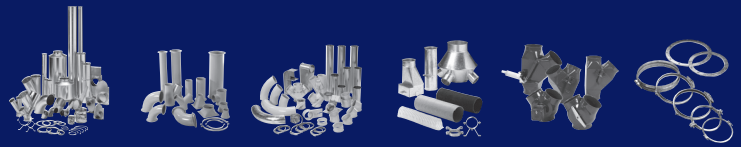

30° and 45° trouser pieces, galvanised

Technical catalogue: Duct systems
 Section: 01
 Page: 13/16
 Revised: 01.05.2009

Diameter: $\varnothing 80 - \varnothing 1000$ mm.

Galvanised trouser pieces are made of 0.90 mm sheet metal.

State A-, B- and C dimensions when ordering.

Trouser pieces are extended by 50 mm on legs B and C when assembled by wide pull rings [f.bb], rapid lock pull rings [f.lyn], or loose flanges [f.b.m.fl].

Kongskilde can also supply trouser pieces in other angles and qualities.

For galvanised trouser pieces:
 $A \geq B$ and $A \geq C$. When $C \neq B$, the highest value of B and C shall be used for calculation.

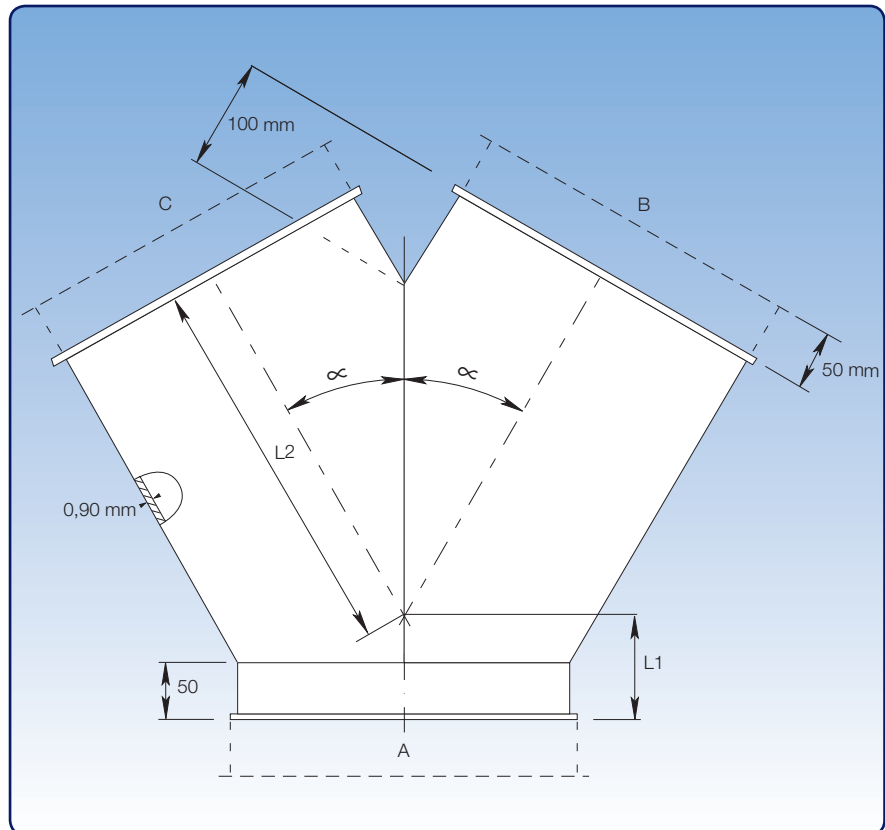

□ = 30° or 45°

Calculation of L1 and L2 for 2 × 30°:

$$L1 = (A \times 0,134) + 50$$

$$L2 = (B \times 0,866) + 100$$

Example:

$$A = B = C = 200$$

$$L1 = (200 \times 0,134) + 50 = 76,8$$

$$L2 = (200 \times 0,866) + 100 = 273,2$$

Calculation of L1 and L2 for 2 × 45°:

$$L1 = (A \times 0,207) + 50$$

$$L2 = (B \times 0,5) + 100$$

Example:

$$A = B = C = 200$$

$$L1 = (200 \times 0,207) + 50 = 91,4$$

$$L2 = (200 \times 0,5) + 100 = 200$$

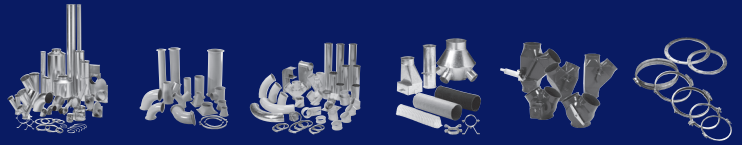

90° T-pieces, galvanised

Technical catalogue: Duct systems
 Section: 02
 Page: 14/16
 Revised: 01.05.2009

Diameter: $\varnothing 80 - \varnothing 1000$ mm.

Galvanised T-pieces are made of 0.90 - 1.00 mm sheet metal (s).

Dimensions: $A=C \geq B$.

State A-, B- and C dimensions when ordering.

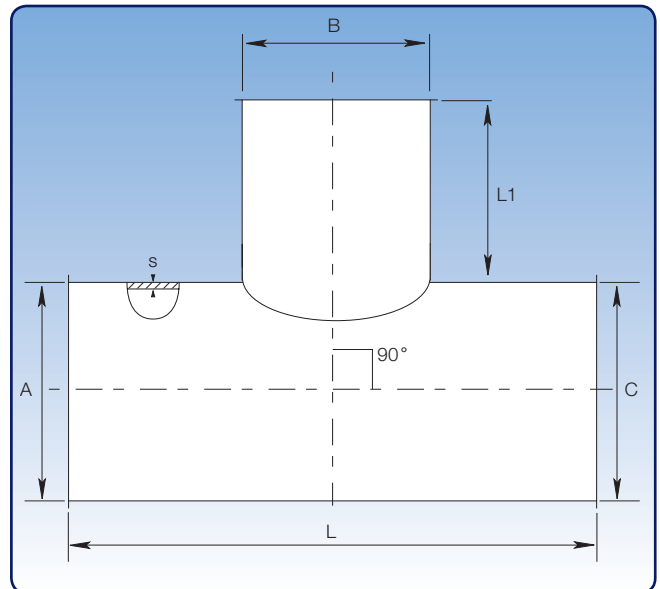

Dimensional specifications are given in the table below.

Dimensions			
B mm	s mm	L mm	L1 mm
80	0,90	230	75
100	0,90	250	75
120	0,90	270	75
125	0,90	275	75
140	0,90	290	75
150	0,90	300	75
160	0,90	310	75
180	0,90	330	75
200	0,90	350	75
225	0,90	425	100
250	0,90	450	100
275	0,90	475	100
300	0,90	500	100
315	0,90	515	100
350	0,90	550	100
400	0,90	600	100
450	0,90	750	150
500	0,90	800	150
550	0,90	850	150
600	0,90	900	150
630	0,90	930	150
650	0,90	950	150
700	0,90	1100	200
750	0,90	1150	200
800	1,00	1200	200
850	1,00	1250	200
900	1,00	1300	200
950	1,00	1350	200
1000	1,00	1400	200

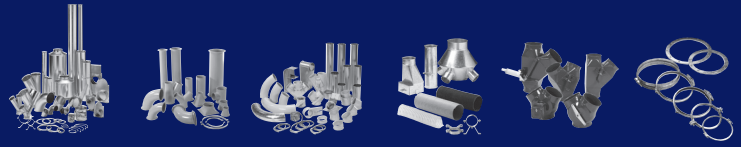

Tapers, galvanised

Technical catalogue: Duct systems
 Section: 01
 Page: 15/16
 Revised: 01.05.2009

Diameter: $\varnothing 80 - \varnothing 1000$ mm.

Tapers are spot welded and made of 0.90 mm galvanised sheet metal.

When assembling with wide pull rings [f.bb], rapid lock pull rings [f.lyn] and loose flanges [f.b.m.fl] length (L) is increased by 2 x 50 mm.

State D- and d dimensions when ordering. Length L is stated in the table below.

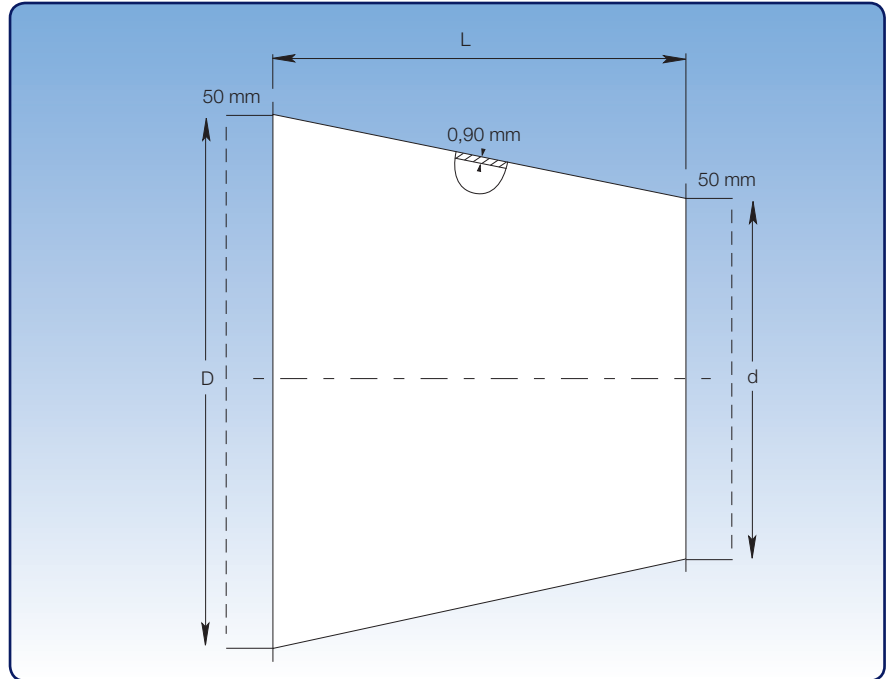

Determining taper length L:

The difference between the larger and smaller diameter (D - d) is plotted on the vertical axis of the coordinate system. By following the line from this point to the intersection, the length (L) can be read at the corresponding point on the horizontal axis.

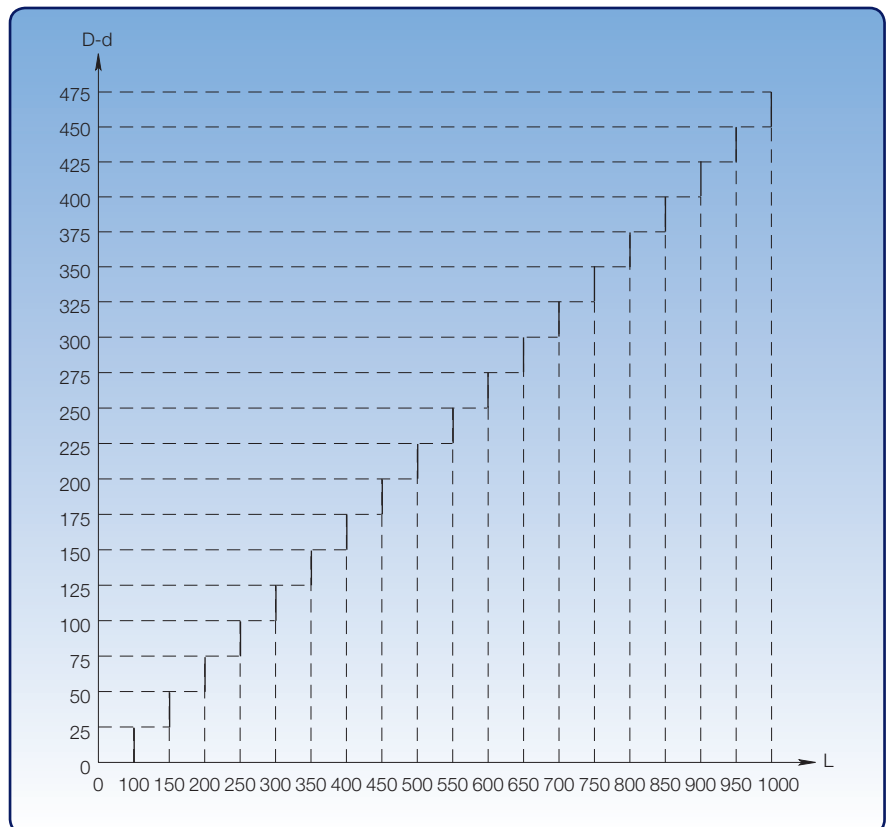

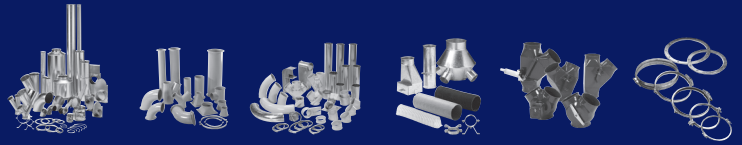

Transition pieces, galvanised

Technical catalogue: Duct systems
 Section: 01
 Page: 16/16
 Revised: 01.05.2009

Diameter: $\varnothing 80 - \varnothing 1000$ mm.

Transition pieces are spot welded and made of 0.90 mm galvanised sheet metal.

Transition pieces can be made to order in other dimensions, and can be made asymmetrical.

State dimensions for BU \times LU and D plus assembly method when ordering (p. 6).

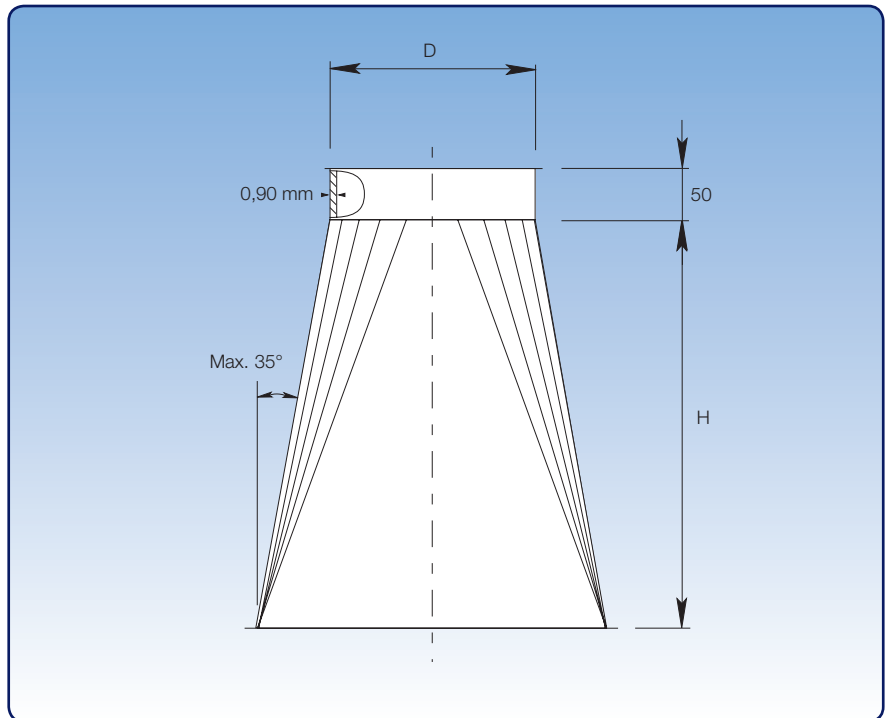

Calculating H:

$$H = 240 + 0,5 \times (\text{max. value of } LU - D) \text{ or } (BU - D)$$

Example

$$D = 350, LU = 400, BU = 600, EXL = 200, EXB = 300$$

$$H = 240 + (0,5 \times 250) = 240 + 125$$

$$H = 365 \text{ mm}$$

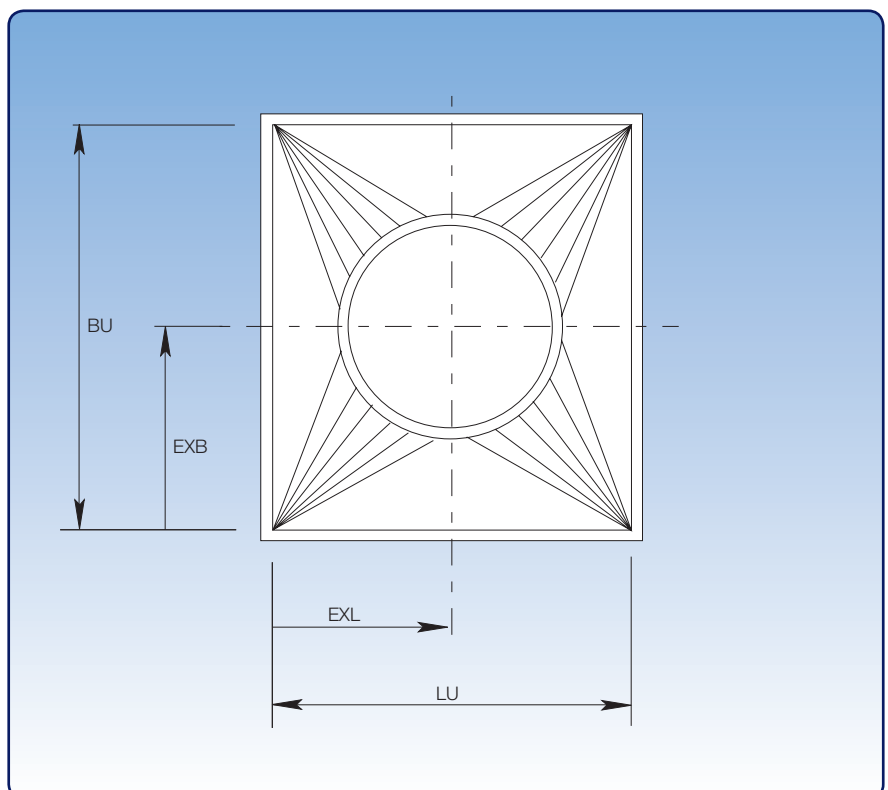

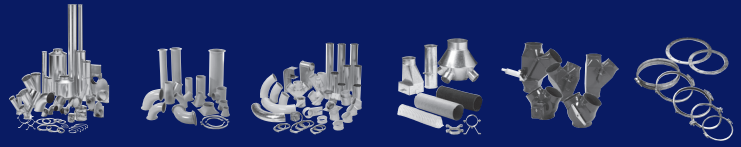

Ducts, 2 and 3 mm

Technical catalogue: Duct systems
 Section: 02
 Page: 1/16
 Revised: 01.05.2009

Diameter for 2 mm: $\varnothing 80 - \varnothing 1250$ mm.

2 and 3 mm ducts $D \leq 600$ mm supplied as standard for pull rings [f.b]. Ducts with $D = \varnothing 630$ mm - $\varnothing 1250$ mm supplied with flanges [m.fl].

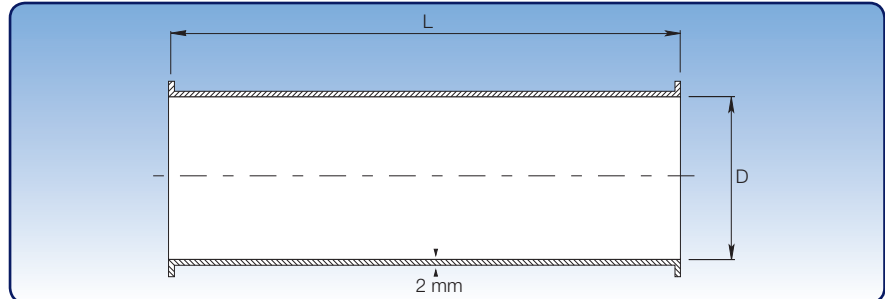

Dimensional specifications are given in the table below.

Dimensions									
D mm	L = 0.2 m		L = 0.5 m		L = 1.0 m		L = 2.0 m		
	Item no.	kg	Item no.	kg	Item no.	kg	Item no.	kg	
80	9251040121	0,80	9251040131	2,00	9251040141	4,00	9251040151	8,00	
100	9251041291	1,10	9251041131	2,50	9251041141	5,00	9251041151	10,00	
120	9251042291	1,30	9251042131	3,10	9251042141	6,20	9251042151	12,40	
125	9251043291	1,40	9251043131	3,20	9251043141	6,40	9251043151	12,80	
140	9251044291	1,50	9251044131	3,50	9251044141	7,00	9251044151	14,20	
150	9251045291	1,60	9251045131	3,80	9251045141	7,60	9251045151	15,20	
160	9251046291	1,70	9251046131	4,10	9251046141	8,20	9251046151	16,40	
180	9251047291	1,80	9251047131	4,60	9251047141	9,10	9251047151	18,20	
200	9251048291	2,10	9251048131	5,10	9251048141	10,20	9251048151	20,40	
225	9251049291	2,40	9251049131	5,80	9251049141	11,30	9251049151	22,70	
250	9251050291	2,70	9251050131	6,30	9251050141	12,60	9251050151	25,20	
300	9251051291	3,20	9251051131	7,60	9251051141	15,20	9251051151	30,40	
315	9251052291	3,30	9251052131	7,70	9251052141	15,50	9251052151	31,00	
350	9251053291	3,80	9251053131	8,90	9251053141	16,80	9251053151	33,80	
400	9251054291	4,30	9251054131	10,10	9251054141	20,20	9251054151	40,40	
450	9251055291	4,90	9251055131	11,40	9251055141	22,80	9251055151	45,60	
500	9251056291	5,40	9251056131	12,60	9251056141	25,20	9251056151	50,40	
550	9251057291	6,00	9251057131	13,90	9251057141	27,80	9251057151	55,60	
600	9251058291	6,60	9251058131	15,20	9251058141	30,40	9251058151	60,80	
630	9251059295	12,80	9251059135	22,30	9251059145	38,20	9251059155	70,00	
650	9251060295	13,20	9251060135	23,00	9251060145	39,40	9251060155	72,00	
700	9251061295	14,20	9251061135	24,70	9251061145	42,30	9251061155	77,50	
750	9251062295	17,80	9251062135	29,00	9251062145	48,00	9251062155	85,80	
800	9251063295	18,90	9251063135	31,00	9251063145	52,20	9251063155	91,70	
850	9251064295	20,00	9251064135	32,90	9251064145	54,40	9251064155	97,00	
900	9251065295	21,20	9251065135	34,80	9251065145	57,40	9251065155	102,70	
950	9251066295	22,40	9251066135	36,80	9251066145	60,80	9251066155	108,80	
1000	9251067295	23,50	9251067135	38,60	9251067145	63,80	9251067155	114,20	
1100	-	-	9251068135	42,50	9251068145	71,10	9251068155	126,50	
1250	-	-	9251069135	45,20	9251069145	76,70	9251069155	129,70	

Item numbers designated with $D \leq 600$ mm are for ducts assembled with pull rings [f.b].

Item numbers designated with $D \geq 630$ mm are for ducts with flanges [m.fl].

2 and 3 mm ducts are also available for other assembly methods. See p. 7 for assembly methods.

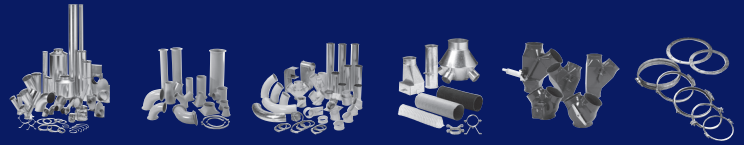

Ducts, 2 and 3 mm

Technical catalogue: Duct systems
 Section: 02
 Page: 2/16
 Revised: 01.05.2009

Diameter for 3 mm: $\varnothing 150 - \varnothing 1250$ mm.

2 and 3 mm ducts $D \leq 600$ mm supplied as standard for pull rings [f.b]. Ducts with $D = \varnothing 630$ mm - $\varnothing 1250$ mm supplied with flanges [m.fl].

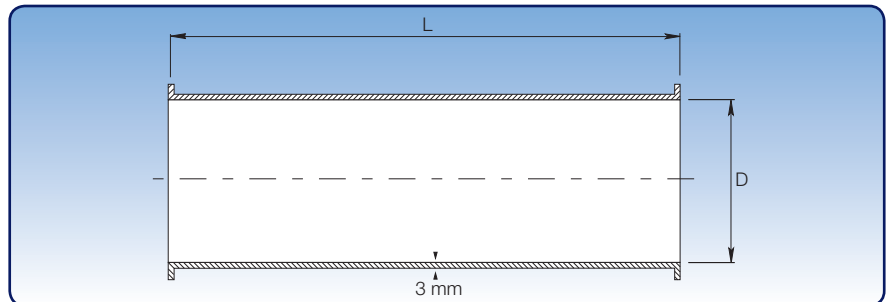

Dimensional specifications are given in the table below.

Dimensions								
D mm	L = 0.2 m		L = 0.5 m		L = 1.0 m		L = 2.0 m	
	Item no.	kg	Item no.	kg	Item no.	kg	Item no.	kg
150	9251045391	2,40	9251045161	5,70	9251045171	11,40	9251045181	22,80
160	9251046391	2,50	9251046161	6,10	9251046171	12,20	9251046181	24,40
180	9251047391	2,70	9251047161	6,80	9251047171	13,60	9251047181	27,20
200	9251048391	3,20	9251048161	7,60	9251048171	15,20	9251048181	30,40
225	9251049391	3,60	9251049161	8,60	9251049171	17,10	9251049181	34,20
250	9251050391	4,00	9251050161	9,60	9251050171	19,00	9251050181	38,00
300	9251051391	4,80	9251051161	11,40	9251051171	22,80	9251051181	45,60
315	9251052391	5,00	9251052161	11,70	9251052171	23,30	9251052181	46,60
350	9251053391	5,70	9251053161	13,30	9251053171	26,60	9251053181	53,20
400	9251054391	6,50	9251054161	15,20	9251054171	30,40	9251054181	60,80
450	9251055391	7,30	9251055161	17,10	9251055171	34,20	9251055181	68,40
500	9251056391	8,10	9251056161	19,00	9251056171	38,00	9251056181	76,00
550	9251057391	8,40	9251057161	20,90	9251057171	41,80	9251057181	83,60
600	9251058391	9,70	9251058161	22,70	9251058171	45,40	9251058181	90,80
630	9251059395	15,90	9251059165	35,20	9251059175	54,00	9251059185	101,60
650	9251060395	16,30	9251060165	31,20	9251060175	55,80	9251060185	105,00
700	9251061395	17,70	9251061165	33,50	9251061175	59,90	9251061185	112,70
750	9251062395	21,50	9251062165	36,00	9251062175	66,80	9251062185	123,40
800	9251063395	23,00	9251063165	41,00	9251063175	71,20	9251063185	131,60
850	9251064395	24,40	9251064165	43,50	9251064175	76,70	9251064185	139,90
900	9251065395	25,70	9251065165	46,10	9251065175	80,00	9251065185	148,10
950	9251066395	27,20	9251066165	48,70	9251066175	84,60	9251066185	156,40
1000	9251067395	28,50	9251067165	52,20	9251067175	89,00	9251067185	168,60
1100	-	-	9251068165	56,30	9251068175	98,00	9251068185	181,00
1250	-	-	9251069165	61,00	9251069175	108,20	9251069185	202,70

Item numbers designated with $D \leq 600$ mm are for ducts assembled with pull rings [f.b].

Item numbers designated with $D \geq 630$ mm are for ducts with flanges [m.fl].

2 and 3 mm ducts are also available for other assembly methods. See p. 7 for assembly methods.

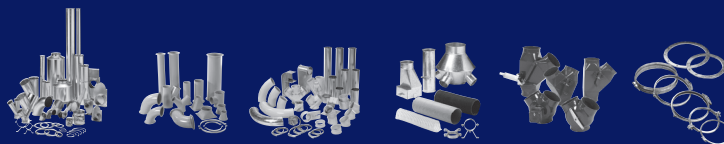

Telescopic ducts, 2 mm

Technical catalogue: Duct systems
 Section: 02
 Page: 3/16
 Revised: 01.05.2009

Diameter: $\varnothing 100 - \varnothing 600$ mm.

Welded telescopic ducts are made of 2.00 mm sheet metal (s), and supplied with rapid lock pull rings with rubber gasket.

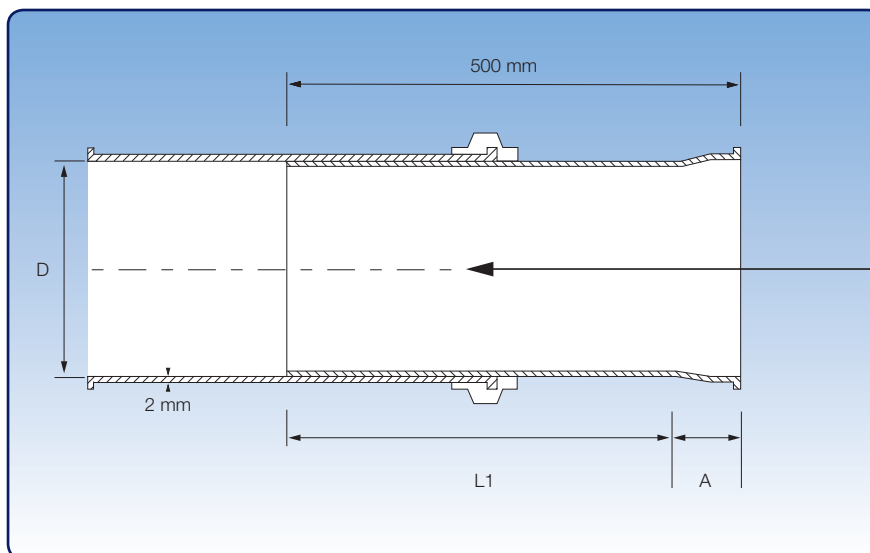

Dimensional specifications are given in the table below.

Dimensions				
Item no.	A mm	L1 mm	D mm	Weight kg
9251069191	55	445	100	2,70
9251069201	55	445	120	3,10
9251069211	55	445	125	3,40
9251069221	65	435	140	3,70
9251069231	65	435	150	3,90
9251069241	65	435	160	4,20
9251069251	65	435	180	4,90
9251069261	65	435	200	5,20
9251069271	65	435	225	5,80
9251069281	65	435	250	6,50
9251069291	65	435	275	6,70
9251069301	65	435	300	7,80
9251069311	65	435	315	8,10
9251069321	65	435	350	9,00
9251069331	65	435	400	10,10
9251069341	65	435	450	11,70
9251069351	70	435	500	12,30
9251069361	70	456	550	14,60
9251069371	70	435	600	15,90

The item numbers stated are for primed telescopic ducts assembled using pull rings [f.b].
 Telescopic ducts are also available for other assembly methods. See p. 7 for assembly methods.

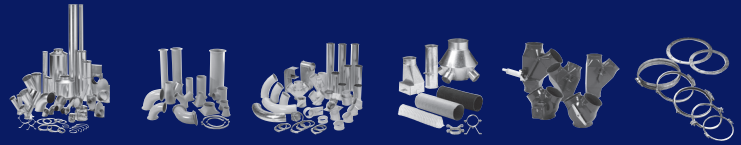

Ducts with direct flange, 2 and 3 mm

Technical catalogue: Duct systems
 Section: 02
 Page: 4/16
 Revised: 01.05.2009

Diameter: $\varnothing 300 - \varnothing 1000$ mm.

Ducts with direct flanges are welded and made of 2.00 and 3.00 mm sheet metal (s).

Ducts are supplied with direct flanges [d.fl] in same material as ducts.

Direct flanges can be fitted along with Kongskilde's standard range of loose and welded flanges.

Item numbers stated are for primed ducts.

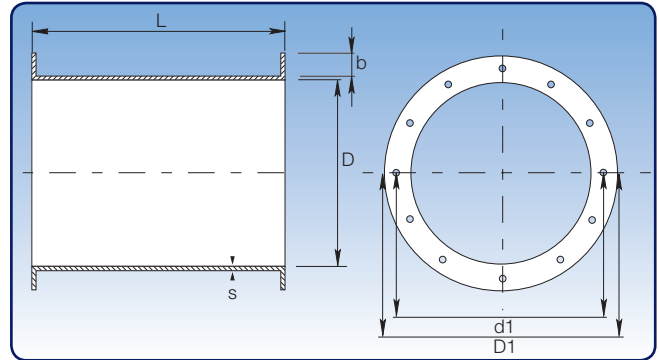

Dimensional specifications are given in the table below.

Dimensions												
D mm	s mm	D1 mm	d1 mm	Weight at L = 0.2 m		Weight at L = 0.5 m		Weight at L = 1.0 m		Weight at L = 2.0 m		Quant. holes
				Item no.	kg	Item no.	kg	Item no.	kg	Item no.	kg	
300	2,00	354	336	9251051299	3,20	9251051139	7,60	9251051149	15,20	9251051159	30,40	12
315	2,00	370	351	9251052299	3,30	9251052139	7,90	9251052149	15,80	9251052159	31,60	12
350	2,00	415	389	9251053299	3,80	9251053139	8,90	9251053149	17,80	9251053159	35,60	12
400	2,00	465	439	9251054299	4,30	9251054139	10,10	9251054149	20,20	9251054159	40,40	16
450	2,00	515	489	9251055299	4,90	9251055139	11,40	9251055149	22,80	9251055159	45,60	16
500	2,00	565	540	9251056299	5,40	9251056139	12,60	9251056149	25,20	9251056159	50,40	16
550	2,00	615	590	9251057299	6,00	9251057139	13,90	9251057149	27,80	9251057159	55,60	16
600	2,00	665	640	9251058299	6,60	9251058139	15,20	9251058149	30,40	9251058159	60,80	16
630	2,00	695	670	9251059299	6,40	9251059139	15,90	9251059149	31,80	9251059159	63,60	24
650	2,00	715	690	9251060299	6,60	9251060139	16,40	9251060149	32,80	9251060159	65,60	24
700	2,00	785	750	9251061299	7,10	9251061139	17,60	9251061149	35,20	9251061159	70,40	24
750	2,00	835	800	9251062299	7,60	9251062139	18,90	9251062149	37,80	9251062159	75,60	24
800	2,00	885	850	9251063299	8,10	9251063139	20,20	9251063149	40,40	9251063159	80,80	24
850	2,00	935	900	9251064299	8,60	9251064139	21,40	9251064149	42,80	9251064159	85,60	24
900	2,00	985	950	9251065299	9,10	9251065139	22,70	9251065149	45,30	9251065159	90,60	24
950	2,00	1035	1000	9251066299	9,60	9251066139	24,00	9251066149	48,00	9251066159	96,00	24
1000	2,00	1085	1050	9251067299	10,10	9251067139	25,20	9251067149	50,40	9251067159	100,80	24
300	3,00	354	336	9251051399	4,80	9251051169	11,40	9251051179	22,80	9251051189	45,60	12
315	3,00	370	351	9251052399	5,00	9251052169	11,90	9251052179	23,70	9251052189	47,40	12
350	3,00	415	389	9251053399	5,70	9251053169	13,30	9251053179	26,60	9251053189	53,20	12
400	3,00	465	439	9251054399	6,50	9251054169	15,20	9251054179	30,40	9251054189	60,80	16
450	3,00	515	489	9251055399	7,30	9251055169	17,10	9251055179	34,20	9251055189	68,40	16
500	3,00	565	540	9251056399	8,10	9251056169	19,00	9251056179	38,00	9251056189	76,00	16
550	3,00	615	590	9251057399	8,40	9251057169	20,90	9251057179	41,80	9251057189	83,60	16
600	3,00	665	640	9251058399	9,70	9251058169	22,70	9251058179	45,40	9251058189	90,80	16
630	3,00	695	670	9251059399	9,50	9251059169	23,80	9251059179	47,60	9251059189	95,20	24
650	3,00	715	690	9251060399	9,70	9251060169	24,60	9251060179	49,20	9251060189	98,40	24
700	3,00	785	750	9251061399	10,60	9251061169	26,40	9251061179	52,80	9251061189	105,60	24
750	3,00	835	800	9251062399	11,30	9251062169	28,30	9251062179	56,60	9251062189	113,20	24
800	3,00	885	850	9251063399	12,10	9251063169	30,20	9251063179	60,40	9251063189	120,80	24
850	3,00	935	900	9251064399	12,90	9251064169	32,10	9251064179	64,20	9251064189	128,40	24
900	3,00	985	950	9251065399	13,60	9251065169	34,00	9251065179	68,00	9251065189	136,00	24
950	3,00	1035	1000	9251066399	14,40	9251066169	35,90	9251066179	71,80	9251066189	143,60	24
1000	3,00	1085	1050	9251067399	15,10	9251067169	37,80	9251067179	75,60	9251067189	151,20	24

Duct length/flange width/hole size

D mm	b mm	L = 0.2 m mm	L = 0.5 m mm	L = 1.0 m mm	L = 2.0 mm	Hole size mm
300 - 315	25	200	455	955	1955	9
350 - 650	30	200	445	945	1945	11
700 - 1000	40	200	425	925	1925	11

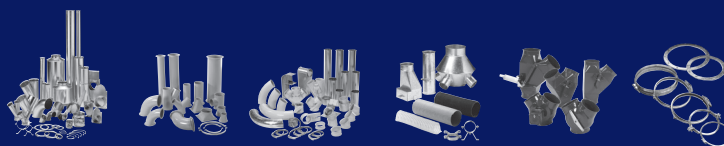

Welding ends, 2 and 3 mm

Technical catalogue: Duct systems
 Section: 02
 Page: 5/16
 Revised: 01.05.2009

Diameter: $\varnothing 80 - \varnothing 600$ mm.

Welding ends are made of 2.00 and 3.00 mm sheet metal (s) and supplied untreated.

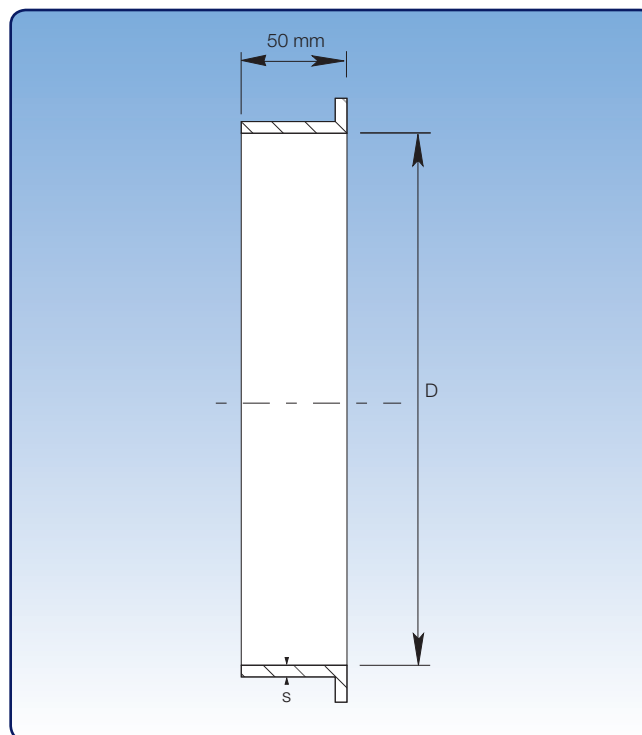

Dimensional specifications are given in the table below.

Dimensions						
D mm	Item no.	s = 2 mm	Weight kg	Item no.	s = 3 mm	Weight kg
80	9251010700		0,22			
100	9251011700		0,27			
120	9251012700		0,33			
125	9251013700		0,34			
140	9251014700		0,38			
150	9251015700		0,41	9251015800		0,62
160	9251016700		0,44	9251016800		0,66
180	9251017700		0,49	9251017800		0,74
200	9251018700		0,55	9251018800		0,82
225	9251019700		0,61	9251019800		0,92
250	9251020700		0,68	9251020800		1,02
275	9251020710		0,75	9251021810		1,12
300	9251021700		0,82	9251021800		1,23
315	9251022700		0,86	9251022800		1,29
350	9251023700		0,95	9251023800		1,43
400	9251024700		1,09	9251024800		1,63
450	9251025700		1,27	9251025800		1,89
500	9251026700		1,36	9251026800		2,04
550	9251027700		1,50	9251027800		2,24
600	9251028700		1,63	9251028800		2,45

The item numbers stated are for primed welding ends assembled using pull rings [f.b].
 Welding ends are also available for other assembly methods. See p. 7 for assembly methods.

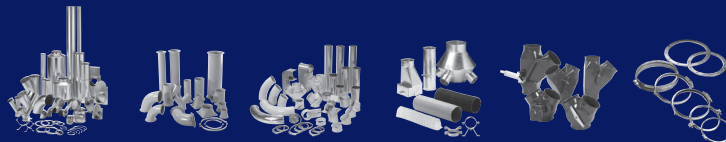

Pressed bends, 2 and 3 mm

Technical catalogue: Duct systems
 Section: 02
 Page: 6/16
 Revised: 01.05.2009

Diameter for 2 mm: $\varnothing 100 - \varnothing 400$ mm.
 Diameter for 3 mm: $\varnothing 150 - \varnothing 200$ mm.

Pressed bends are made of 2.00 and 3.00 mm sheet metal (s).

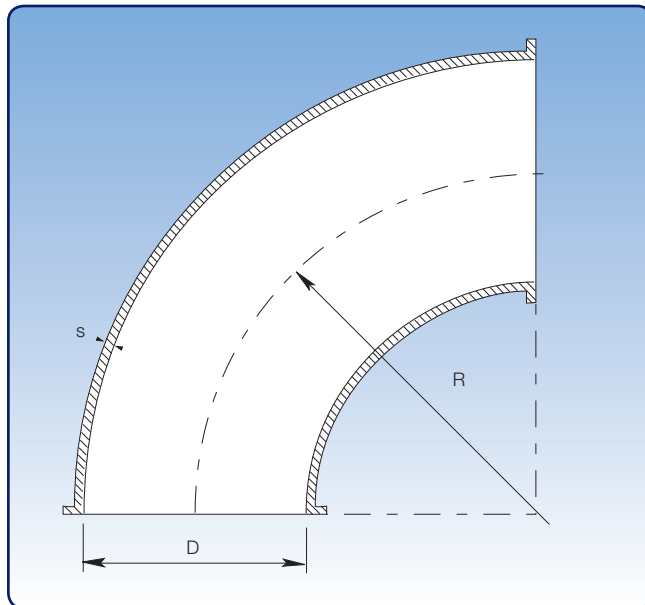

Dimensional specifications are given in the table below.
 $R = 1.5 \times D$ for all dimensions.

Dimensions											
D	s	90°		60°		45°		30°		15°	
mm	mm	Item no.	kg	Item no.	kg	Item no.	kg	Item no.	kg	Item no.	kg
100	2,00	9251141292	1,20	9251141262	0,90	9251141242	0,60	9251141232	0,40	9251141212	0,20
120	2,00	9251142292	1,80	9251142262	1,20	9251142242	0,90	9251142232	0,60	9251142212	0,30
125	2,00	9251143292	2,00	9251143262	1,30	9251143242	1,00	9251143232	0,70	9251143212	0,40
150	2,00	9251145292	2,90	9251145262	2,00	9251145242	1,40	9251145232	1,00	9251145212	0,50
160	2,00	9251146292	3,20	9251146262	2,20	9251146242	1,60	9251146232	1,10	9251146212	0,70
180	2,00	9251147292	3,80	9251147262	2,70	9251147242	1,90	9251147232	1,40	9251147212	0,70
200	2,00	9251148292	5,00	9251148262	3,40	9251148242	2,50	9251148232	1,70	9251148212	0,70
250	2,00	9251150292	8,90	9251150262	5,90	9251150242	4,40	9251150232	2,90	9251150212	1,40
300	2,00	9251151292	12,90	9251151262	7,60	9251151242	6,40	9251151232	4,30	9251151212	1,90
350	2,00	9251153292	17,80	9251153262	12,00	9251153242	9,30	9251153232	5,20	9251153212	3,20
400	2,00	9251154292	23,50	9251154262	15,70	9251154242	11,80	9251154232	7,50	9251154212	4,10
150	3,00	9251145392	4,30	9251145362	3,00	9251145342	2,20	9251145332	1,50	9251145312	0,80
160	3,00	9251146392	4,80	9251146362	3,20	9251146342	2,40	9251146332	1,60	9251146312	1,00
180	3,00	9251147392	6,20	9251147362	4,10	9251147342	3,10	9251147332	2,10	9251147312	1,10
200	3,00	9251148392	7,50	9251148362	5,10	9251148342	3,70	9251148332	2,50	9251148312	1,30

The item numbers stated are for primed pressed bends assembled using pull rings [f.b].
 Pressed bends are also available for other assembly methods. See p. 7 for assembly methods.

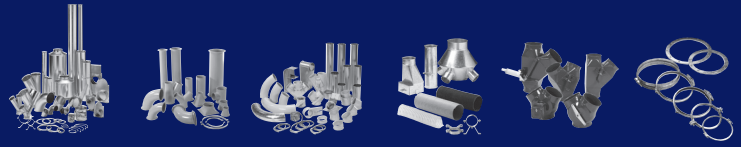

Segment bends, 2 and 3 mm

Technical catalogue: Duct systems
Section: 02
Page: 7/16
Revised: 01.05.2009

Diameter for 2 mm: $\varnothing 140 - \varnothing 1000$ mm.
Diameter for 3 mm: $\varnothing 225 - \varnothing 1000$ mm.

Segment bends are available in other radii and dimensions to order.

2 and 3 mm segment bends are supplied as standard for pull rings [f.b]. Segment bends with $D = \varnothing 630$ mm - $\varnothing 1000$ mm supplied with flange [m.fl].

Dimensional specifications are given in the table below.
 $R = 1.5 \times D$ for all dimensions.

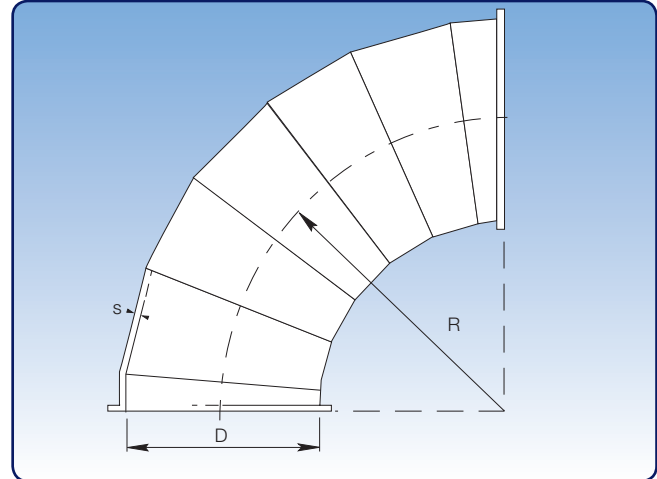

Dimensions											
D mm	s mm	90°		60°		45°		30°		15°	
		Item no.	kg	Item no.	kg	Item no.	kg	Item no.	kg	Item no.	kg
140	2,00	9251144292	2,90	9251144262	2,00	9251144242	1,40	9251144232	1,00	9251144212	0,50
225	2,00	9251149292	7,60	9251149262	5,20	9251149242	3,80	9251149232	2,60	9251149212	1,40
275	2,00	92511588929	9,60	92511588629	7,20	92511588429	4,80	9251152232	3,60	92511588129	1,80
315	2,00	9251152292	13,30	9251152262	8,60	9251152242	6,50	92511588329	4,40	9251152212	2,20
450	2,00	9251155892	24,20	9251155862	16,20	9251155842	12,10	9251155832	8,10	9251155812	4,00
500	2,00	9251156892	29,90	9251156862	20,00	9251156842	15,00	9251156832	10,00	9251156812	5,00
550	2,00	9251157892	36,20	9251157862	24,20	9251157842	18,10	9251157832	12,10	9251157812	6,00
600	2,00	9251158892	43,10	9251158862	28,80	9251158842	21,60	9251158832	14,40	9251158812	7,20
630	2,00	9251159895	53,78	9251159865	38,08	9251159845	30,18	9251159835	22,18	9251159815	14,28
650	2,00	9251160895	57,17	9251160865	40,37	9251160845	31,87	9251160835	23,47	9251160815	14,97
700	2,00	9251161895	65,85	9251161865	46,25	9251161845	36,45	9251161835	26,65	9251161815	16,85
750	2,00	9251162895	77,67	9251162865	55,17	9251162845	43,97	9251162835	32,67	9251162815	21,20
800	2,00	9251163895	87,61	9251163865	62,01	9251163845	49,21	9251163835	36,41	9251163815	23,61
850	2,00	9251164895	98,25	9251164865	69,25	9251164845	54,85	9251164835	40,35	9251164815	25,95
900	2,00	9251165895	109,40	9251165865	77,00	9251165845	60,80	9251165835	44,50	9251165815	28,30
950	2,00	9251166895	121,14	9251166865	85,04	9251166845	66,94	9251166835	48,84	9251166815	30,84
1000	2,00	9251167895	133,58	9251167865	93,48	9251167845	73,48	9251167835	53,48	9251167815	33,38
225	3,00	9251149392	11,10	9251149362	7,40	9251149342	5,60	9251149332	3,70	9251149312	1,90
250	3,00	9251150392	11,10	9251150362	7,40	9251150342	5,60	9251150332	3,70	9251150312	1,90
275	3,00	92511589929	14,40	92511589629	10,80	92511589429	7,20	92511589329	5,40	92511589129	2,70
300	3,00	9251151392	16,10	9251151362	10,70	9251151342	8,00	9251151332	5,40	9251151312	2,70
315	3,00	9251152392	19,65	9251152362	12,90	9251152342	9,75	9251152332	6,60	9251152312	3,30
350	3,00	9251153392	22,00	9251153362	14,60	9251153342	11,00	9251153332	7,30	9251153312	3,70
400	3,00	9251154392	28,60	9251154362	19,10	9251154342	14,30	9251154332	9,50	9251154312	4,80
450	3,00	9251155992	36,40	9251155962	24,20	9251155942	18,20	9251155932	12,10	9251155912	6,10
500	3,00	9251156992	44,90	9251156962	29,90	9251156942	22,40	9251156932	15,00	9251156912	7,50
550	3,00	9251157992	54,40	9251157962	36,20	9251157942	27,20	9251157932	18,10	9251157912	9,10
600	3,00	9251158992	64,70	9251158962	43,20	9251158942	32,40	9251158932	21,60	9251158912	10,80
630	3,00	9251159995	77,48	9251159965	53,78	9251159945	41,98	9251159935	30,08	9251159915	18,28
650	3,00	9251160995	82,57	9251160965	57,17	9251160945	44,57	9251160935	31,87	9251160915	19,27
700	3,00	9251161995	95,25	9251161965	65,85	9251161945	51,15	9251161935	36,45	9251161915	21,75
750	3,00	9251162995	111,47	9251162965	77,67	9251162945	60,77	9251162935	43,97	9251162915	27,07
800	3,00	9251163995	126,01	9251163965	87,61	9251163945	68,41	9251163935	49,21	9251163915	30,01
850	3,00	9251164995	141,35	9251164965	98,05	9251164945	76,55	9251164935	54,85	9251164915	33,15
900	3,00	9251165995	158,10	9251165965	109,40	9251165945	75,10	9251165935	60,80	9251165915	36,40
950	3,00	9251166995	175,34	9251166965	121,14	9251166945	94,04	9251166935	66,94	9251166915	39,84
1000	3,00	9251167995	193,68	9251167965	133,58	9251167945	103,58	9251167935	73,48	9251167915	43,48

Item numbers designated with $D \leq 600$ mm are for segment bends assembled with pull rings [f.lyn]. Item numbers designated with $D \geq 630$ mm are for ducts with flange [m.fl]. 2 and 3 mm ducts are also available for other assembly methods. See p. 7 for assembly methods.

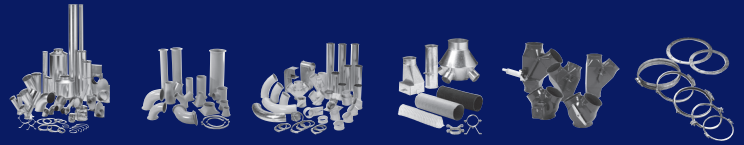

30° straight branch pieces, 2 and 3 mm

Technical catalogue: Duct systems
Section: 02
Page: 8/16
Revised: 01.05.2009

Diameter for 2 mm: ø100 - ø1000 mm.
Diameter for 3 mm: ø150 - ø1000 mm.

Straight branch pieces are welded and made of 2.00 and 3.00 mm sheet metal (s). Straight branch pieces with $A = C \leq 600$ mm are supplied for assembly with pull rings [f.b] and for $A = C \geq 630$ mm with flanges [m.fl].

When assembled with loose flanges, [f.b.m.fl], and flanges [m.fl] L1 is extended by 2×50 mm.

State A-, B- and C dimensions when ordering. Options are limited by $A = C$, and $A \geq B$.

The branch determines the length of L1. Branch pieces are always straight with the branch centrally located.

L1, L2 and L3 can be calculated using the stated formulas.

For double branch pieces, the highest value of dim. B determines L1 on the common branch. L2 and L3 can then be calculated for both branches. Normally, the branches are opposite each other.

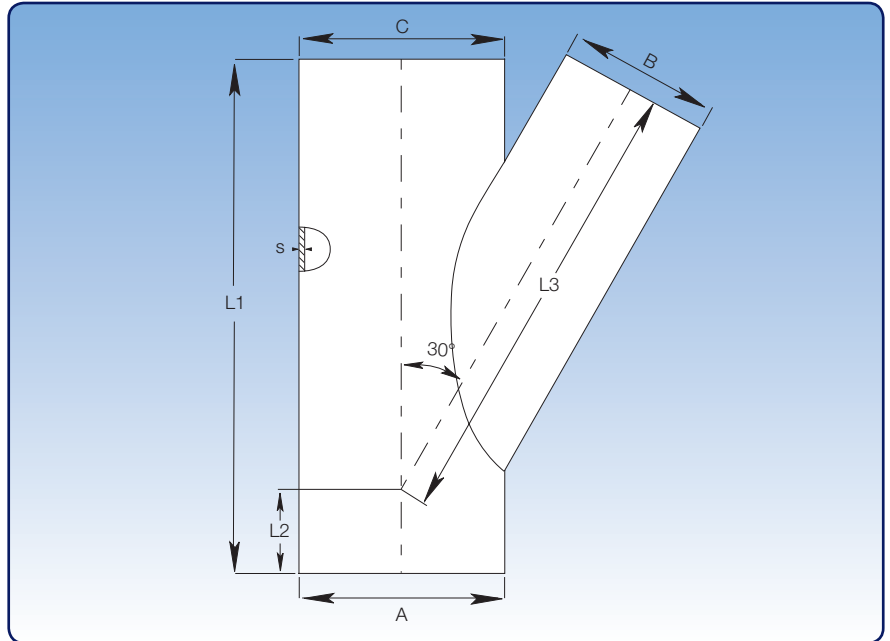

Calculating L2 and L3:

L1 = see table

$$L2 = \frac{L1}{2} - \left(\frac{A}{2} \times \tan 30^\circ \right)$$

$$L3 = \frac{L1 - L2}{\cos 30^\circ} - \left(\frac{B}{2} \times \tan 30^\circ \right)$$

Example:

$A = B = C = 450$

$L1 = 1250$ mm

$$L2 = \frac{1250}{2} - \left(\frac{450}{2} \times \tan 30^\circ \right) = 625 - 389,71$$

$L2 = 235,29$ p 235 mm

$$L3 = \frac{1250 - 235}{\cos 30^\circ} - \left(\frac{450}{2} \times \tan 30^\circ \right) = 1172,06 - 129,92$$

$L3 = 1042,14$ p 1042 mm

A = C mm	Dimensions			
	B mm	L1 mm	L2 mm	L3 mm
Select (100 - 1000)	80	350	Calculate	Calculate
	100	350		
	120	350		
	125	400		
	140	450		
	150	450		
	160	450		
	180	550		
	200	550		
	225	600		
	250	750		
	275	750		
	300	750		
	315	850		
	350	950		
	400	1050		
	450	1250		
	500	1250		
	550	1450		
	600	1450		
650	1650			
700	1650			
750	1850			
800	1850			
850	2050			
900	2050			

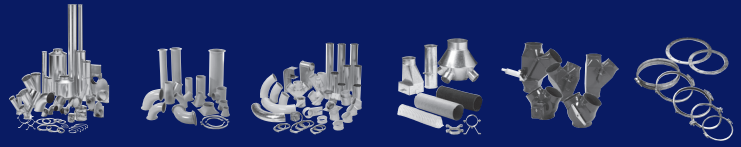

45° straight branch pieces, 2 and 3 mm

Technical catalogue: Duct systems
Section: 02
Page: 9/16
Revised: 01.05.2009

Diameter for 2 mm: ø100 - ø1000 mm.
Diameter for 3 mm: ø150 - ø1000 mm.

Straight branch pieces are welded and made of 2.00 and 3.00 mm sheet metal (s). Straight branch pieces with $A = C \leq 600$ mm are supplied for assembly with pull rings [f.b] and for $A = C \geq 630$ mm with flanges [m.fl]. When assembled with loose flanges, [f.b.m.fl], and flanges [m.fl] L1 is extended by 2×50 mm.

State A-, B- and C dimensions when ordering. Options are limited by $A = C$, and $A \geq B$.

The branch determines the length of L1. Branch pieces are always straight with the branch centrally located. L1, L2 and L3 can be calculated using the stated formulas.

For double branch pieces, the highest value of dim. B determines L1 on the common branch. L2 and L3 can then be calculated for both branches. Normally, the branches are opposite each other.

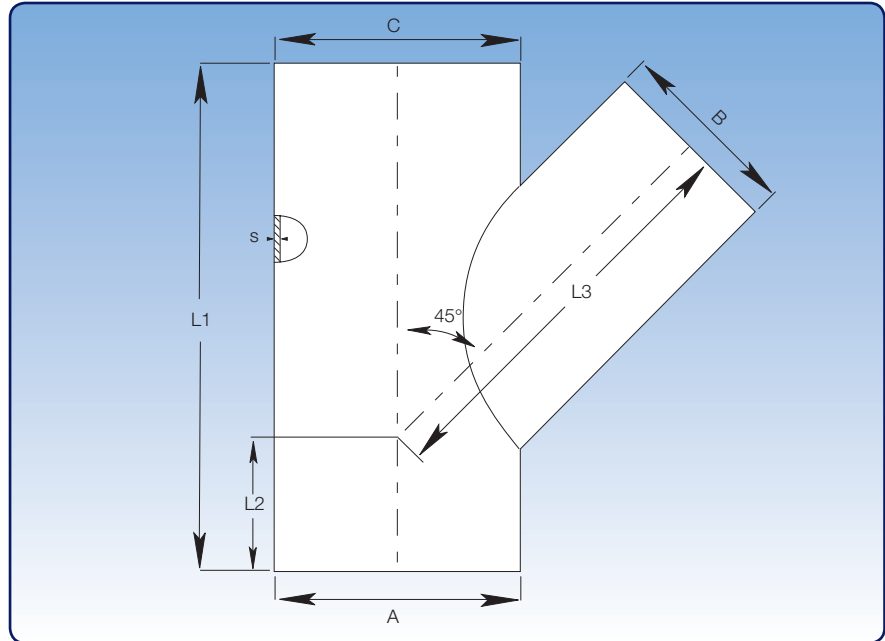

Calculating L2 and L3:

L1 = see table

$$L2 = \frac{L1}{2} - \left(\frac{A}{2} \times \text{tg } 45^\circ \right)$$

$$L3 = \frac{L1 - L2}{\cos 45^\circ} - \left(\frac{B}{2} \times \text{tg } 45^\circ \right)$$

Example:

$A = B = C = 600$

$L1 = 1150$ mm

$$L2 = \frac{1150}{2} - \frac{600}{2} = 575 - 300$$

$L2 = 275$ mm

$$L3 = \frac{1150 - 275}{\cos 45^\circ} - \left(\frac{600}{2} \times \text{tg } 45^\circ \right)$$

$L3 = 1237,44 - 300$

$L3 = 937,44$ p 937 mm

Dimensions				
A = C mm	B mm	L1 mm	L2 mm	L3 mm
Select (100 - 1000)	80	300	Calculate	Calculate
	100	300		
	120	350		
	125	350		
	140	350		
	150	400		
	160	400		
	180	400		
	200	450		
	225	500		
	250	500		
	275	600		
	300	600		
	315	600		
	350	700		
	400	800		
	450	950		
	500	950		
	550	1050		
	600	1150		
650	1150			
700	1300			
750	1300			
800	1450			
850	1450			
900	1650			

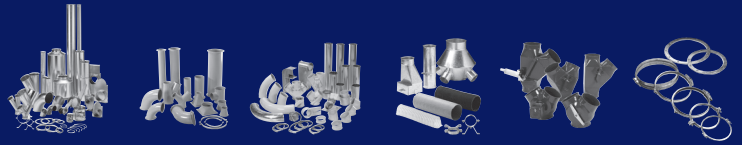

30° conical branch pieces, 2 and 3 mm

Technical catalogue: Duct systems
Section: 02
Page: 10/16
Revised: 01.05.2009

Diameter A for 2 mm: ø120 - ø1000 mm.
Diameter A for 3 mm: ø150 - ø1000 mm.

Conical branch pieces are welded and made of 2.00 and 3.00 mm sheet metal (s). Conical branch pieces with A ≤ 600 mm are supplied for assembly with pull rings [f.b] and for A ≥ 630 mm with flanges [m.fl].

L1 is extended by a 50 mm welding end at dimension C if the branch piece is supplied with flanges [m.fl], loose flanges [f.b.m.fl] or rapid lock pull rings [f.lyn].

State branch piece A-, B- and C dimensions when ordering. A, B and C can be combined to order; although branch B determines length L1 as stated in the table.

Maximum difference between diameter A and C is 100 mm. For B applies: $B < (A+C)/2$.

The highest value of dimension B determines L1 on the common stem for double branch pieces. L2 and L3 can then be calculated for both branches. Normally, the branches are opposite each other.

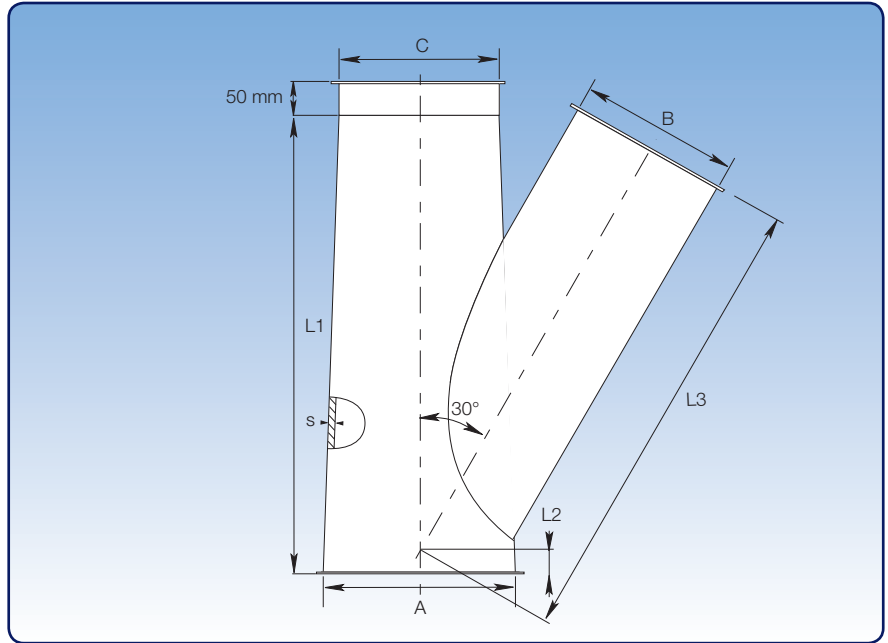

Calculating L2 and L3:

L1 = See table

$$L2 = \left(\frac{L1}{2} \right) - \left(\frac{A + C}{4 \times \tan 30^\circ} \right)$$

$$L3 = \left(\frac{L1 - L2}{\cos 30^\circ} \right) - \left(\frac{B}{2} \times \tan 30^\circ \right)$$

Example:

A = 500, B = 300, C = 400

L1 = 750 mm

$$L2 = \frac{750}{2} - \frac{500 + 400}{4 \times \tan 30^\circ} = 375 - 389,71$$

L2 = - 14,71 p - 15 mm

$$L3 = \frac{750 - 15}{\cos 30^\circ} - \left(\frac{300}{2} \times \tan 30^\circ \right) = 848,70 - 86,61$$

L3 = 762,1 p 762 mm

Dimensions					
A mm	B mm	C mm	L1 mm	L2 mm	L3 mm
Select (100 - 1000)	80	Select (100 - 1000)	350	Calculate	Calculate
	100		350		
	120		350		
	125		400		
	140		450		
	150		450		
	160		450		
	180		550		
	200		550		
	225		600		
	250		750		
	275		750		
	300		750		
	315		850		
	350		950		
	400		1050		
	450		1250		
	500		1250		
	550		1250		
600	1450				
650	1650				
700	1650				
750	1850				
800	1850				
850	2050				
900	2050				

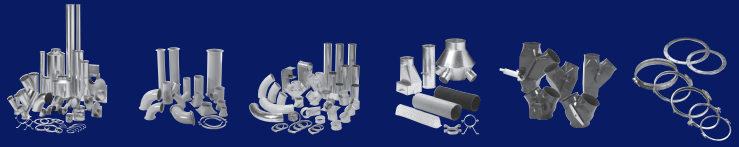

45° conical branch pieces, 2 and 3 mm

Technical catalogue: Duct systems
Section: 02
Page: 11/16
Revised: 01.05.2009

Diameter A for 2 mm: ø120 - ø1000 mm.
Diameter A for 3 mm: ø150 - ø1000 mm.

Conical branch pieces are welded and made of 2.00 and 3.00 mm sheet metal (s). Conical branch pieces with A ≤ 600 mm are supplied for assembly with pull rings [f.b] and for A ≥ 630 mm with flanges [m.fl].

L1 is extended by a 50 mm welding end at dimension C if the branch piece is supplied with flanges [m.fl], loose flanges [f.b.m.fl] or rapid lock pull rings [f.lyn].

State branch piece A-, B- and C dimensions when ordering. A, B and C can be combined to order; although branch B determines length L1 as stated in the table.

Maximum difference between diameter A and C is 100 mm. For B applies: $B < (A+C)/2$.

The highest value of dimension B determines L1 on the common stem for double branch pieces. L2 and L3 can then be calculated for both branches. Normally, the branches are opposite each other.

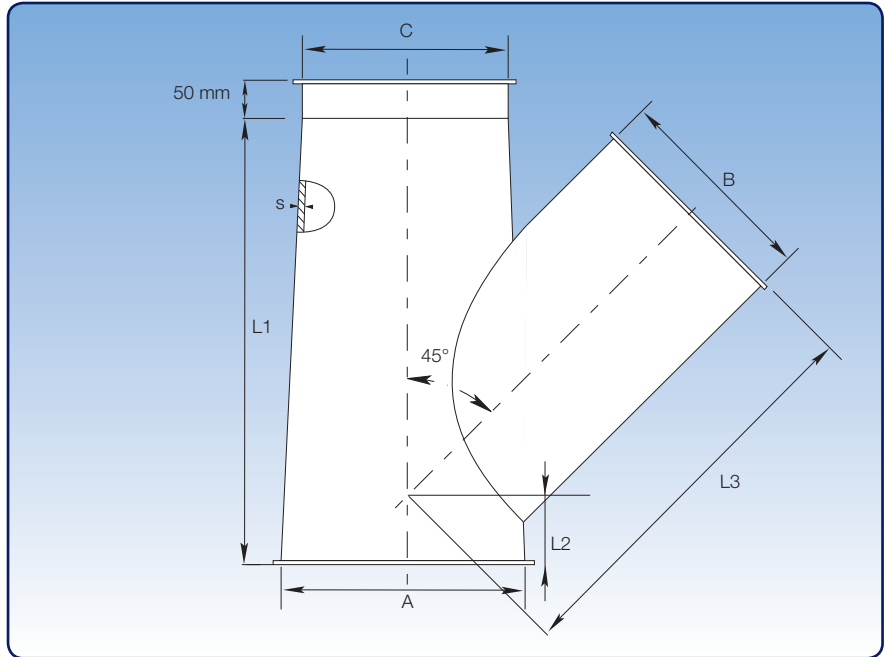

Calculating L2 and L3:

L1 = See table

$$L2 = \left(\frac{L1}{2} \right) - \left(\frac{A+C}{4 \times \text{tg } 45^\circ} \right)$$

$$L3 = \left(\frac{L1-L2}{\cos 45^\circ} \right) - \left(\frac{B}{2} \times \text{tg } 45^\circ \right)$$

Example:

A = 650, B = 315, C = 600

L1 = 600 mm

$$L2 = \frac{600}{2} - \frac{650 + 600}{4 \times \text{tg } 45^\circ} = 300 - 312,5$$

L2 = - 12,5 p - 13 mm

$$L3 = \frac{600 + 13}{\cos 45^\circ} - \left(\frac{315}{2} \times \text{tg } 45^\circ \right) = 866,92 - 157,5$$

L3 = 709,42 p 709 mm

Dimensions					
A mm	B mm	C mm	L1 mm	L2 mm	L3 mm
Select (100 - 1000)	80	Select (100 - 1000)	300	Calculate	Calculate
	100		300		
	120		350		
	125		350		
	140		350		
	150		400		
	160		400		
	180		400		
	200		450		
	225		500		
	250		500		
	275		600		
	300		600		
	315		600		
	350		700		
	400		800		
	450		950		
	500		1050		
	550		1150		
600	1250				
650	1150				
700	1300				
750	1300				
800	1450				
850	1450				
900	1650				

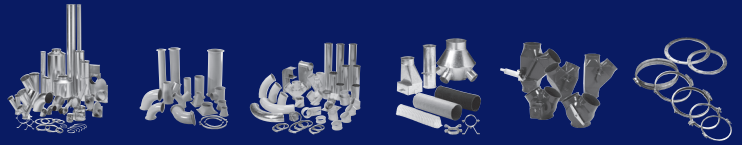

30° trouser pieces, 2 and 3 mm

Technical catalogue: Duct systems
 Section: 02
 Page: 12/16
 Revised: 01.05.2009

Diameter A for 2 mm: $\varnothing 100 - \varnothing 1000$ mm.
 Diameter A for 3 mm: $\varnothing 150 - \varnothing 1000$ mm.

Trouser pieces are welded and made of 2.00 and 3.00 mm sheet metal (s).

Trouser pieces with $A = B = C \leq 600$ mm are supplied for assembly with pull rings [f.b].

Trouser pieces with $A = B = C \geq 630$ mm are supplied for assembly with flanges [m.fl].

Produced as straight trouser pieces when $A=B=C$.

State A, B and C dimensions when ordering.

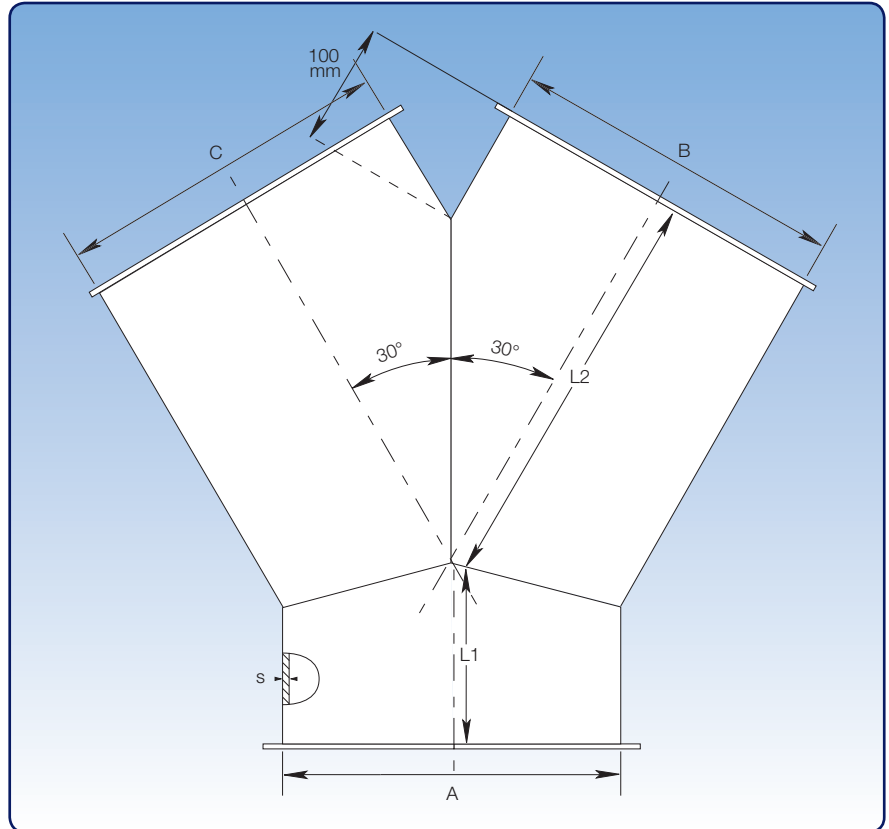

Calculating L1 and L2:

$$L1 = 0,5 \times A$$

$$L2 = \cos 30^\circ \times A + 100$$

Example:

$$A = B = C = 350$$

$$L1 = 0,5 \times 350 = 175$$

$$L1 = 175 \text{ mm}$$

$$L2 = (0,866 \times 350) + 100 = 403,1$$

$$L2 = 403 \text{ mm}$$

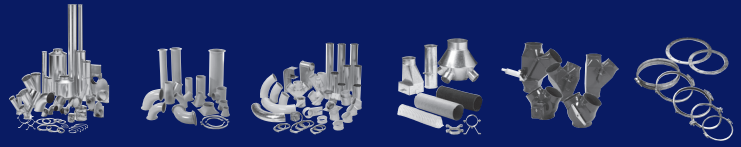

90° T-pieces, 2 and 3 mm

Technical catalogue: Duct systems
 Section: 02
 Page: 13/16
 Revised: 01.05.2009

Diameter for 2 mm: $\varnothing 80 - \varnothing 1000$ mm.
 Diameter for 3 mm: $\varnothing 150 - \varnothing 1000$ mm.

90° T-pieces are welded and made of 2.00 and 3.00 mm sheet metal (s). T-pieces with $A = C \leq 600$ mm are supplied for assembly with pull rings [f.b]. T-pieces with $A = C \geq 630$ mm are supplied with flanges [m.fl].

For dimensions: $A = C \geq B$.

State A, B and C dimensions when ordering.

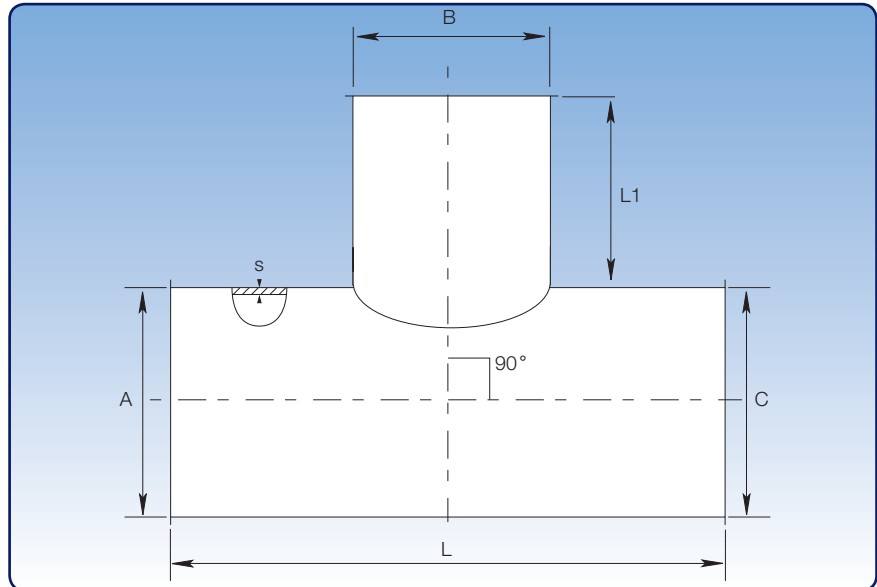

Dimensional specifications are given in the table below.

Dimensions			
B mm	s mm	L mm	L1 mm
80	2,00	230	75
100	2,00	250	75
120	2,00	270	75
125	2,00	275	75
140	2,00	290	75
150	2,00 and 3,00	300	75
160	2,00 and 3,00	310	75
180	2,00 and 3,00	330	75
200	2,00 and 3,00	350	75
225	2,00 and 3,00	425	100
250	2,00 and 3,00	450	100
275	2,00 and 3,00	475	100
300	2,00 and 3,00	500	100
315	2,00 and 3,00	515	100
350	2,00 and 3,00	550	100
400	2,00 and 3,00	600	100
450	2,00 and 3,00	750	150
500	2,00 and 3,00	800	150
550	2,00 and 3,00	850	150
600	2,00 and 3,00	900	150
630	2,00 and 3,00	930	150
650	2,00 and 3,00	950	150
700	2,00 and 3,00	1100	200
750	2,00 and 3,00	1150	200
800	2,00 and 3,00	1200	200
850	2,00 and 3,00	1250	200
900	2,00 and 3,00	1300	200
950	2,00 and 3,00	1350	200
1000	2,00 and 3,00	1400	200

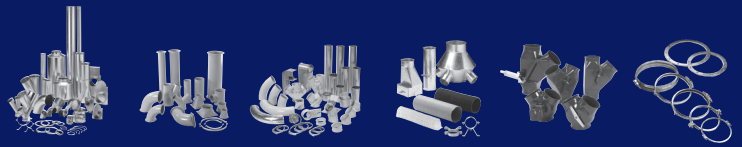

Tapers, 2 and 3 mm

Technical catalogue: Duct systems
 Section: 02
 Page: 14/16
 Revised: 01.05.2009

Diameter A for 2 mm: $\varnothing 100 - \varnothing 1000$ mm.
 Diameter A for 3 mm: $\varnothing 160 - \varnothing 1000$ mm.

Tapers are made in standard dimensions as stated in the table. Other dimensions can be made to order. Tapers with $A \leq 600$ mm are supplied as standard for assembly with pull rings [f.b]. Tapers with $A \geq 630$ mm are supplied as standard with flanges [m.fl]. When ordering standard tapers, state A and B dimensions and assembly method. L will depend on the difference between A and B.

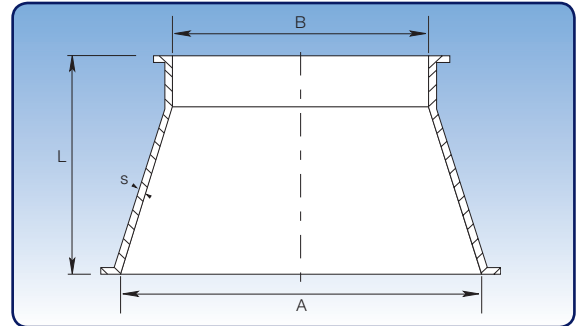

Dimensional specifications for standard tapers are given in the table below.

Dimensions						
Item no.	A mm	B mm	s mm	L mm	Weight kg	
9251842417	100	80	2,00	150	0,74	
9251842428	120	100	2,00	150	0,89	
9251844435	125	100	2,00	150	0,92	
9251844437	125	120	2,00	150	0,92	
9251844448	140	100	2,00	200	1,38	
9251846454	150	100	2,00	200	1,48	
9251846455	150	120	2,00	200	1,48	
9251846456	150	125	2,00	150	1,11	
9251846457	150	140	2,00	150	1,11	
9251847464	160	100	2,00	250	1,97	
9251847465	160	120	2,00	200	1,58	
9251847466	160	125	2,00	200	1,58	
9251847467	160	150	2,00	150	1,18	
9251847468	160	140	2,00	150	1,18	
9251848475	180	100	2,00	300	1,84	
9251848476	180	125	2,00	250	1,68	
9251848477	180	150	2,00	200	1,57	
9251849482	200	100	2,00	300	1,98	
9251849483	200	125	2,00	250	1,79	
9251849484	200	140	2,00	250	1,88	
9251849485	200	150	2,00	200	1,65	
9251849486	200	160	2,00	200	1,68	
9251849487	200	180	2,00	150	1,36	
9251850496	225	180	2,00	150	1,66	
9251850497	225	200	2,00	200	2,22	
9251851399	250	150	2,00	300	3,70	
9251851401	250	160	2,00	300	3,70	
9251851403	250	180	2,00	250	3,08	
9251851405	250	200	2,00	200	2,47	
9251851407	250	225	2,00	150	1,85	
9251852110	275	250	2,00	150	2,03	
9251852111	275	225	2,00	200	2,71	
9251852112	275	200	2,00	250	3,39	
9251852415	300	200	2,00	300	4,44	
9251852416	300	225	2,00	250	3,70	
9251852417	300	250	2,00	200	2,96	
9251852418	300	275	2,00	150	2,22	
9251853426	315	300	2,00	150	2,33	
9251853427	315	275	2,00	200	3,11	
9251853428	315	250	2,00	250	3,88	
9251854435	350	250	2,00	300	5,18	
9251854436	350	275	2,00	200	3,45	
9251854437	350	300	2,00	250	4,32	
9251855445	400	315	2,00	300	5,92	
9251855446	400	350	2,00	300	5,92	
9251855447	400	300	2,00	250	4,93	

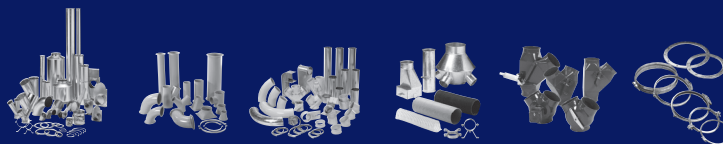

Tapers, 2 and 3 mm

Technical catalogue: Duct systems
 Section: 02
 Page: 15/16
 Revised: 01.05.2009

Dimensions						
Item no.	A mm	B mm	s mm	L mm	Weight kg	
9251856458	450	350	2,00	200	4,44	
9251857466	500	450	2,00	300	6,66	
9251857467	450	400	2,00	200	4,93	
9251857468	500	400	2,00	300	7,40	
9251858478	550	450	2,00	300	8,14	
9251859488	600	500	2,00	300	8,88	
9251860498	630	550	2,00	300	14,82	
9251861408	650	550	2,00	300	15,17	
9251862418	700	600	2,00	300	17,38	
9251863428	750	650	2,00	300	19,94	
9251864438	800	700	2,00	300	11,84	
9251865448	850	750	2,00	300	21,71	
9251866458	900	800	2,00	300	23,63	
9251867458	950	850	2,00	300	24,97	
9251868458	1000	900	2,00	300	26,30	
9251846760	160	150	3,00	150	1,78	
9251849780	200	150	3,00	200	2,66	
9251849781	200	160	3,00	200	2,74	
9251849782	200	180	3,00	150	2,16	
9251850796	225	180	3,00	200	3,03	
9251850797	225	200	3,00	150	2,39	
9251851706	250	225	3,00	150	2,66	
9251851707	250	200	3,00	200	3,48	
9251852210	275	250	3,00	150	3,00	
9251852211	275	225	3,00	200	3,11	
9251852715	300	200	3,00	300	5,77	
9251852717	300	250	3,00	200	4,14	
9251852718	300	275	3,00	150	3,22	
9251853727	315	275	3,00	200	4,44	
9251853728	315	300	3,00	150	3,44	
9251854735	350	300	3,00	200	4,88	
9251854736	350	315	3,00	200	5,03	
9251855748	400	350	3,00	200	5,62	
9251856758	450	400	3,00	200	6,36	
9251857767	500	400	3,00	300	10,21	
9251857768	500	450	3,00	200	7,10	
9251858778	550	450	3,00	300	11,32	
9251859788	600	500	3,00	300	12,43	
9251860798	630	550	3,00	300	18,60	
9251861708	650	550	3,00	300	19,09	
9251862718	700	600	3,00	300	21,67	
9251883728	750	650	3,00	300	24,60	
9251864738	800	700	3,00	300	26,00	
9251865748	850	750	3,00	300	27,71	
9251866758	900	800	3,00	300	29,40	
9251867758	950	850	3,00	300	31,11	
9251868758	1000	900	3,00	300	32,81	

Specifications for relationship between diameter (A - B) and length (L) for non-standard tapers. Length L will depend on the difference between A and B. Please state A, B and L measurements when ordering.

A - B [mm]	25	50	75	100	125	150	175	200	225	250	275	300
L [mm]	100	150	200	250	300	350	400	450	500	550	600	650

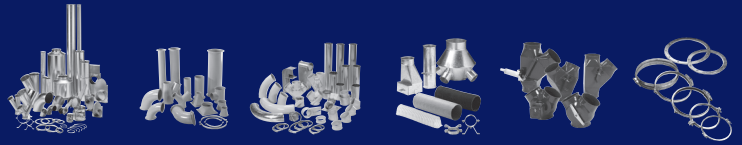

Transition pieces, 2 and 3 mm

Technical catalogue: Duct systems
 Section: 02
 Page: 16/16
 Revised: 01.05.2009

Diameter D for 2 mm: $\varnothing 120 - \varnothing 1000$ mm.
 Diameter D for 3 mm: $\varnothing 150 - \varnothing 1000$ mm.

Transition pieces are made of 2.00 and 3.00 mm sheet metal (s).

Transition pieces with $D \leq 600$ mm are supplied as standard for assembly with pull rings [f.b]. Transition pieces with $D \geq 650$ mm are supplied with flanges [m.fl].

State dimensions for BU \times LU and D plus assembly method when ordering (p. 7).

Can be made to order in other dimensions. Also available in asymmetric format.

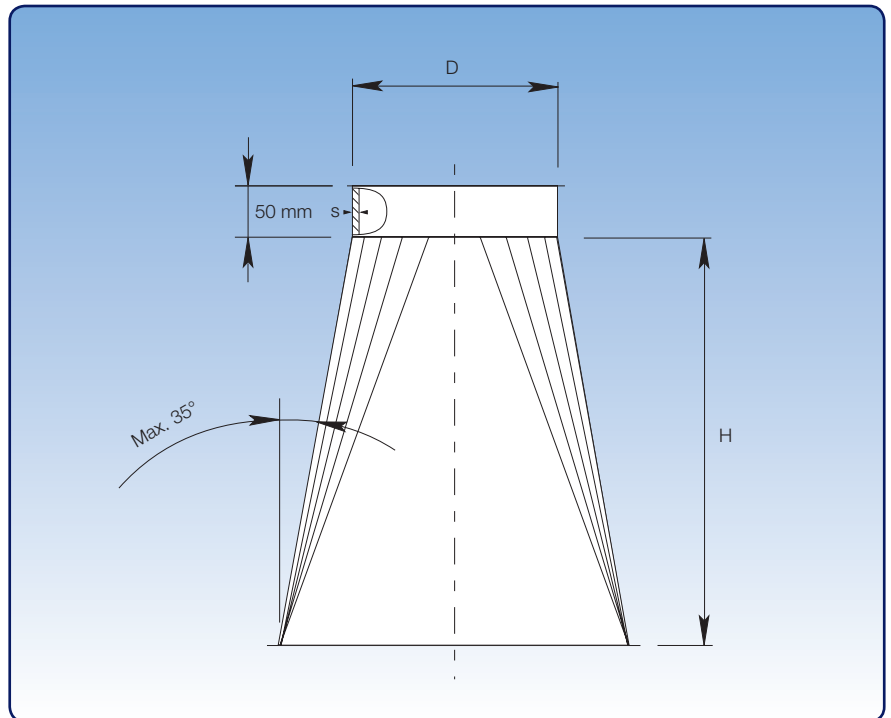

Calculating H:

$$H = 240 + 0,5 \times (\text{max. value of LU} - D)$$

or (BU - D)

Example:

$$D = 350, LU = 400, BU = 600, EXL = 200, EXB = 300$$

$$H = 240 + (0,5 \times 250) = 240 + 125$$

$$H = 365 \text{ mm}$$

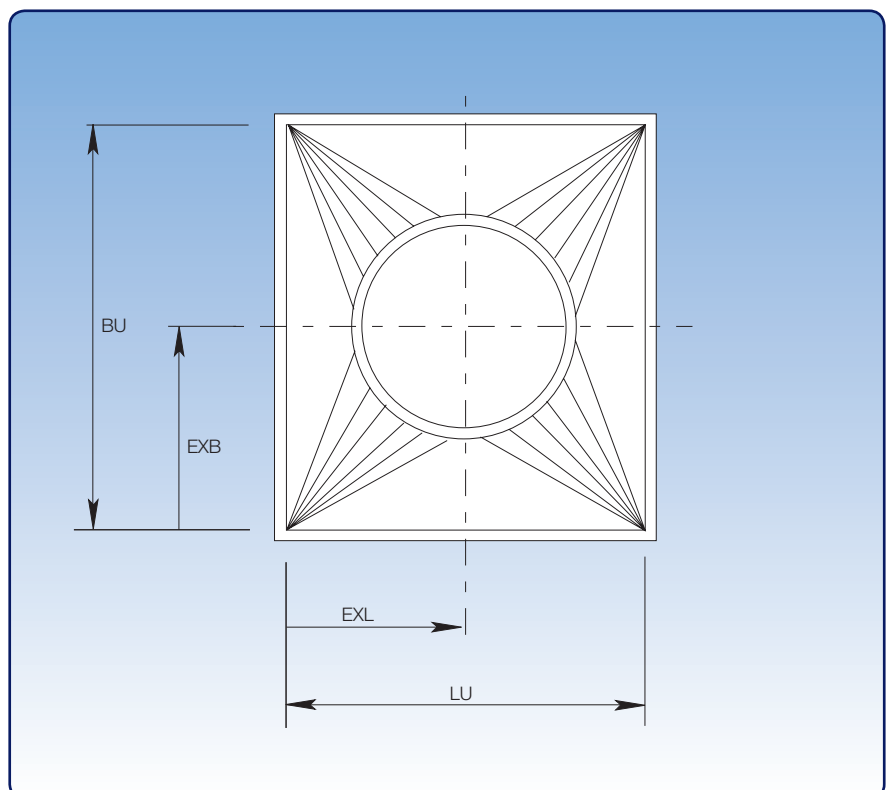

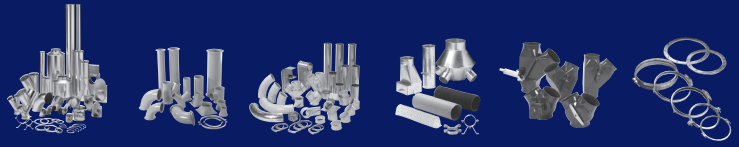

Automation for sliding dampers, throttle valves and diverters

Technical catalogue: Duct systems
 Section: 04
 Page: 1/12
 Revised: 01.05.2009

The circuit diagrams shown apply to standard systems for sliding dampers, diverters and throttle valves.

These systems are valid for pneumatic connection of max. 6 bar and mains connection of 230 V AC. Systems with other voltage ratings can be supplied.

Relevant circuit diagrams can be supplied for other voltages.

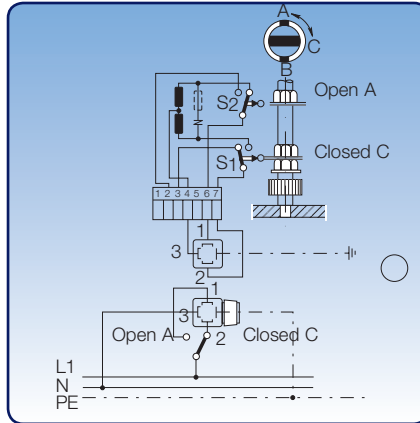

Circuit diagram for electrical motor for diverters, pressed, diameter: $\varnothing 100 - \varnothing 300$ mm.

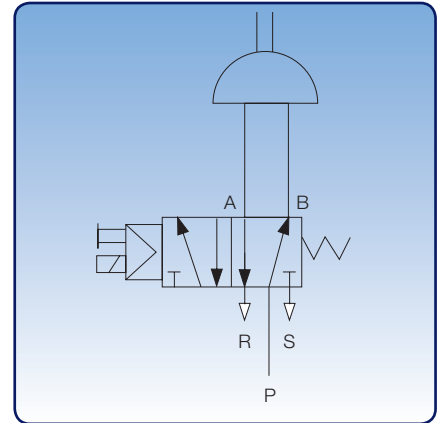

Circuit diagram for pneumatic actuator for diverters, pressed, diameter: $\varnothing 100 - \varnothing 300$ mm and throttle valves, diameter: $\varnothing 80 - \varnothing 400$ mm.

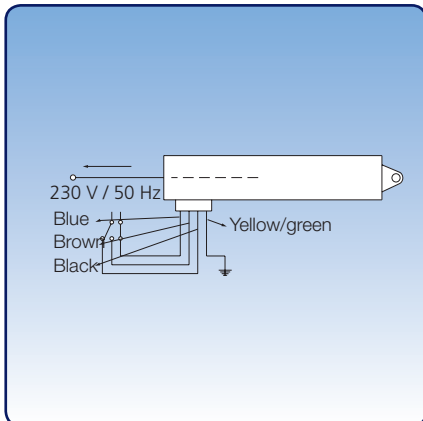

Circuit diagram for electrical cylinder for diverters, welded, diameter: $\varnothing 80 - \varnothing 550$ mm and sliding damper standard, diameter: $\varnothing 80 - \varnothing 275$ mm.

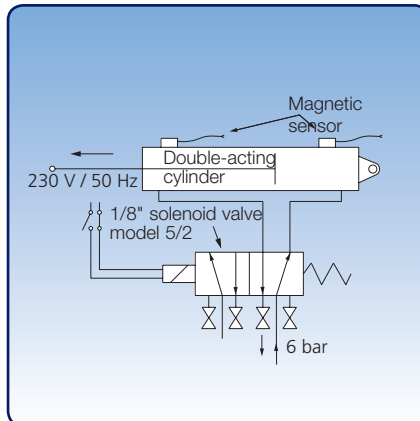

Circuit diagram for pneumatic cylinder for diverters, welded, diameter: $\varnothing 80 - \varnothing 550$ mm and sliding damper standard, diameter: $\varnothing 80 - \varnothing 550$ mm.

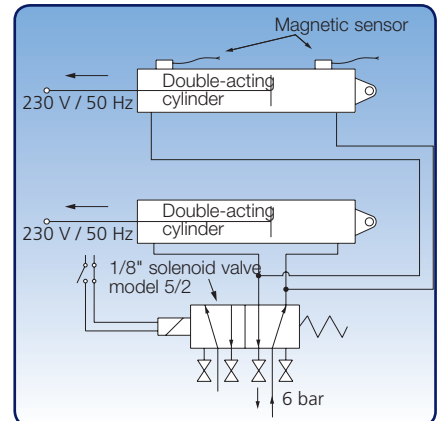

Circuit diagram for 2 pneumatic cylinders for fight sliding dampers, diameter: $\varnothing 80 - \varnothing 550$ mm.

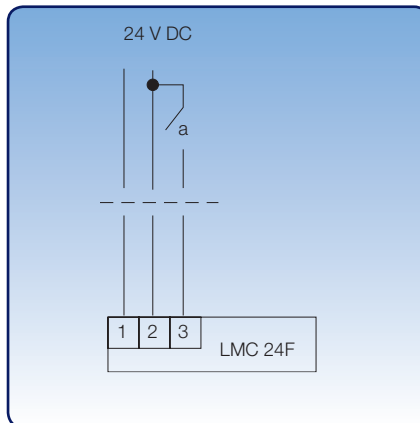

Circuit diagram for 24 V DC electric motor for throttle valves.

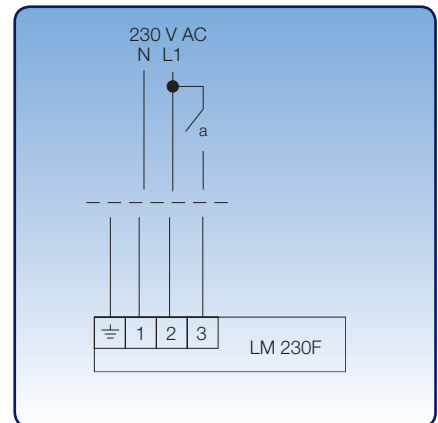

Circuit diagram for 230 V AC electric motor for throttle valves.

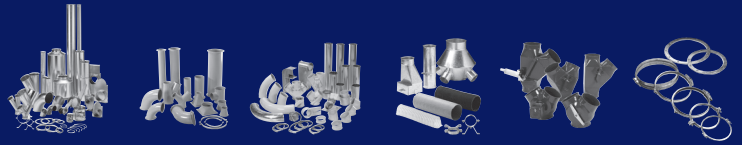

Tight sliding dampers, galva- nised, manual & pneumatic

Technical catalogue: Duct systems
Section: 04
Page: 2/12
Revised: 01.05.2009

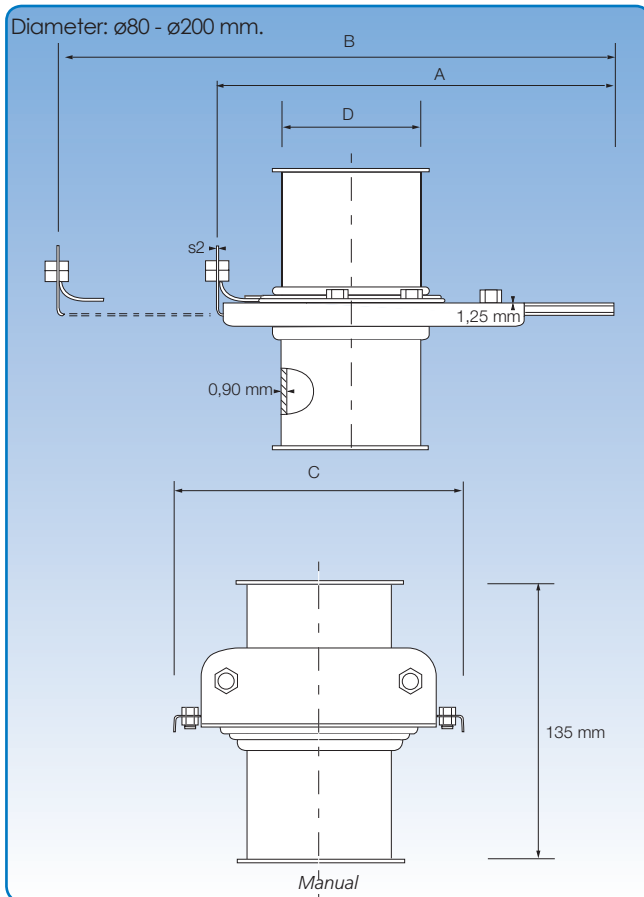

Dimensional specifications are given in the table below.

General

Sliding dampers are made of form-pressed half-parts, in 1.25 mm galvanised sheet metal.

The damper plate slides in the polyether and PEHD gaskets to ensure optimum tightness.

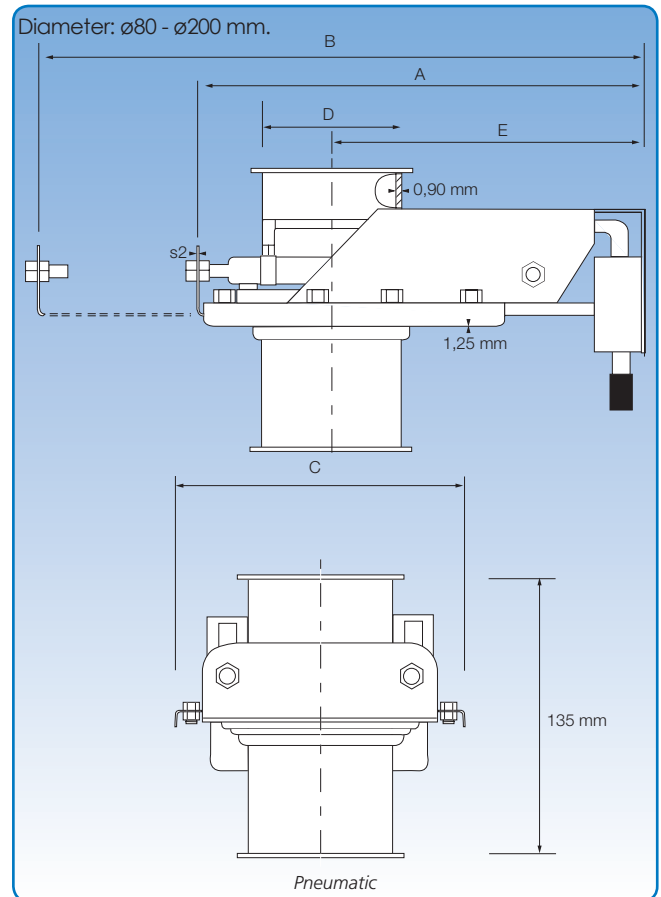

Dimensional specifications are given in the table below.

With pneumatic actuator

The pneumatic damper is fitted with 2 pneumatic cylinders running in parallel.

Solenoid valve: monostable 5/2 valve with 1 x 230 V AC - 50/60 Hz electric coil or 24 V DC. Pneumatic pressure: 4-6 bar.

Dimensions											
Item no. (Man.)	Item no. (Pneu.)	D mm	s2 mm	A (Man.) mm	A (Pneu.) mm	B (Man.) mm	B (Pneu.) mm	C mm	E mm	Weight (Man.) kg	Weight (Pneu.) kg
9251410112	9251410412	80	1,50	225	260	320	355	160	190	1,20	2,30
9251411112	9251411412	100	1,50	265	305	380	415	190	225	1,50	3,80
9251412112	9251412412	120	2,00	325	360	460	500	215	260	2,10	3,60
9251413112	9251413412	125	2,00	325	360	460	500	215	260	2,10	3,60
9251414112	9251414412	140	2,00	375	415	540	580	240	300	2,90	3,80
9251415112	9251415412	150	2,00	375	415	540	580	240	300	2,90	4,40
9251416112	9251416412	160	2,00	405	445	585	620	250	325	3,20	4,90
9251418112	9251418412	180	2,00	455	495	655	695	290	355	4,10	6,00
9251420112	9251420412	200	2,00	485	525	705	745	300	385	4,40	6,30

The item numbers stated are for sliding dampers assembled using pull rings [f.b].

Sliding dampers are also available for other assembly methods. See p. 6 for assembly methods.

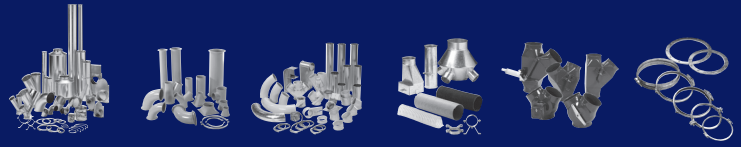

Tight sliding dampers, galvanised, manual & pneumatic

Technical catalogue: Duct systems
 Section: 04
 Page: 3/12
 Revised: 01.05.2009

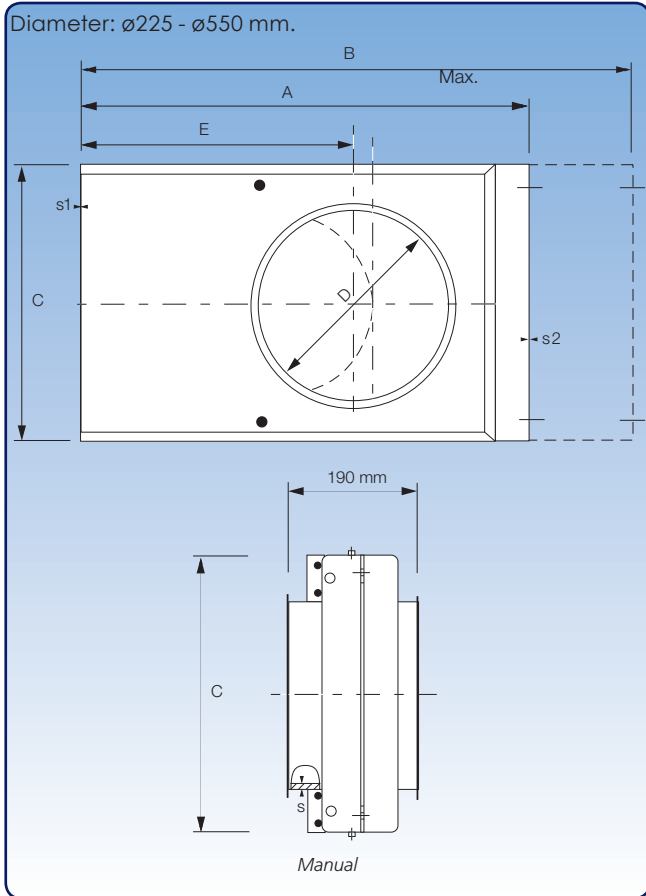

Dimensional specifications are given in the table below.

General

Sliding dampers are made of 1.50 mm, 2.00 mm and 2.50 mm galvanised sheet metal (s).
 The damper plate slides in the polyether and PEHD gaskets to ensure optimum tightness.

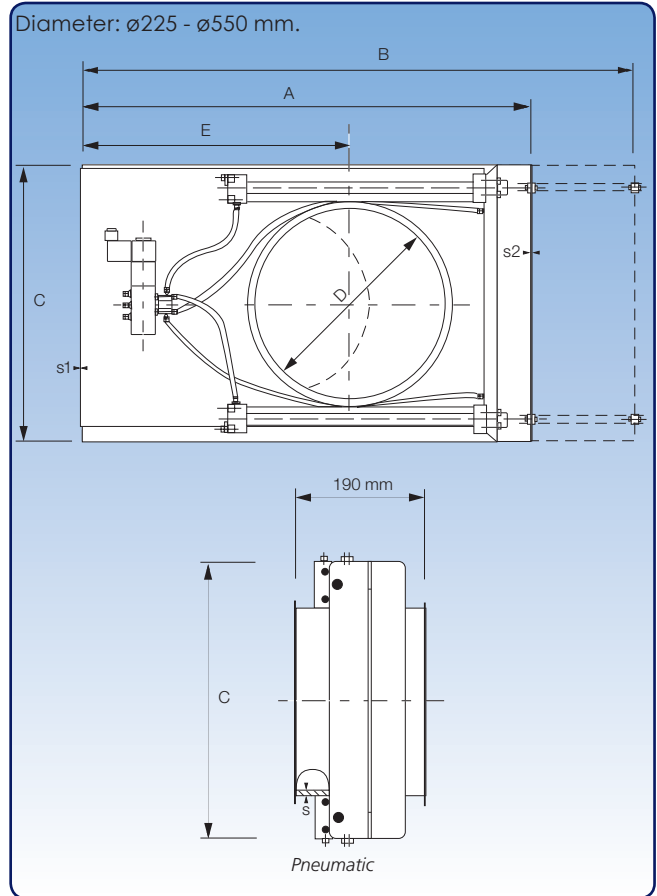

Dimensional specifications are given in the table below.

With pneumatic actuator

The pneumatic damper is fitted with 2 pneumatic cylinders running in parallel.
 Solenoid valve: monostable 5/2 valve with 1 x 230 V AC - 50/60 Hz electric coil or 24 V DC. Pneumatic pressure: 4-6 bar.

Dimensions											
Item no. (Man.)	Item no. (Pneu.)	D mm	s mm	s1 mm	s2 mm	A mm	B max. mm	C mm	E mm	Weight (Man.) kg	Weight (Pneu.) kg
9251422112	9251422412	225	1,50	1,50	2,50	580	830	360	390	10,70	13,40
9251425112	9251425412	250	1,50	1,50	2,50	660	960	385	455	14,00	15,00
9251427112	9251427412	275	2,00	2,00	3,00	680	980	410	465	17,60	19,78
9251430112	9251430412	300	2,00	2,00	3,00	725	1045	435	495	18,90	21,00
9251431112	9251431412	315	2,00	2,00	3,00	855	1255	485	600	25,40	27,90
9251435112	9251435412	350	2,00	2,00	3,00	855	1255	485	600	24,60	26,00
9251440112	9251440412	400	2,00	2,50	3,00	1005	1505	545	725	35,60	36,84
9251445112	9251445412	450	2,00	2,50	3,00	1055	1555	595	750	40,60	44,60
9251450112	9251450412	500	2,00	3,00	3,00	1140	1670	645	805	50,50	56,20
9251455112	9251455412	550	2,00	3,00	3,00	1301	1901	691	915	60,70	65,30

The item numbers stated are for sliding dampers assembled using pull rings [f.b].
 Sliding dampers are also available for other assembly methods. See p. 6 for assembly methods.

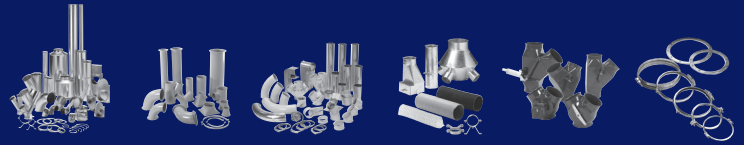

Sliding dampers, galvanised, manual

Technical catalogue: Duct systems
 Section: 04
 Page: 4/12
 Revised: 01.05.2009

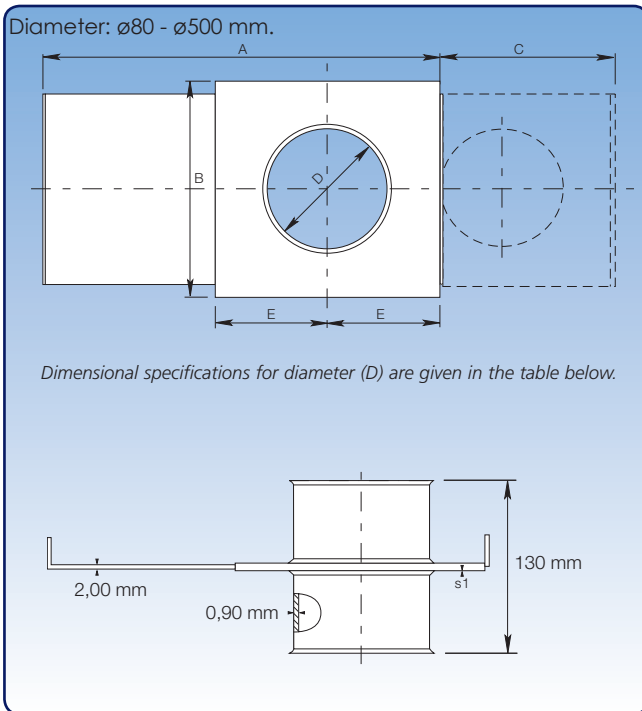

Dimensional specifications for integration length (L) are given in the table below.

Sliding dampers are made of 1.25 and 1.50 mm galvanised sheet metal with a damper of 2.00 mm galvanised sheet metal.

Item no. (Man.)	Dimensions						Weight kg
	D mm	s1 mm	A mm	B mm	C mm	E mm	
9251470112	80	1,25	255	145	105	75	1,10
9251471112	100	1,25	340	185	150	95	1,60
9251472112	120	1,25	340	185	150	95	1,70
9251473112	125	1,25	340	185	150	95	1,80
9251474112	140	1,25	405	225	175	115	2,40
9251475112	150	1,25	405	225	175	115	2,30
9251476112	160	1,25	405	225	175	115	2,30
9251477112	180	1,25	525	295	225	150	3,80
9251478112	200	1,25	525	295	225	150	4,00
9251479112	225	1,50	590	325	270	160	4,60
9251480112	250	1,50	650	350	300	175	5,20
9251480142	275	1,50	705	380	325	190	6,40
9251481112	300	1,50	755	400	345	205	6,50
9251481142	315	1,50	785	420	365	210	7,00
9251482112	350	1,50	885	450	435	200	7,60
9251483112	400	1,50	960	500	460	250	9,30
9251485112	450	1,50	1050	550	500	275	10,70
9251486112	500	1,50	1160	600	550	300	14,10

The item numbers stated are for sliding dampers assembled using pull rings [f.b].
 Sliding dampers are also available for other assembly methods. See p. 6 for assembly methods.

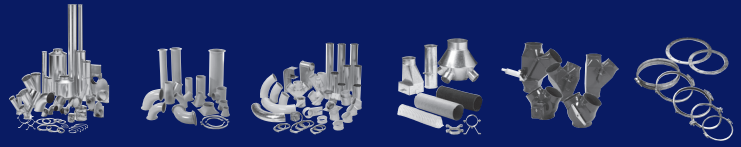

Sliding dampers, galvanised, pneumatic and electric

Technical catalogue: Duct systems
 Section: 04
 Page: 5/12
 Revised: 01.05.2009

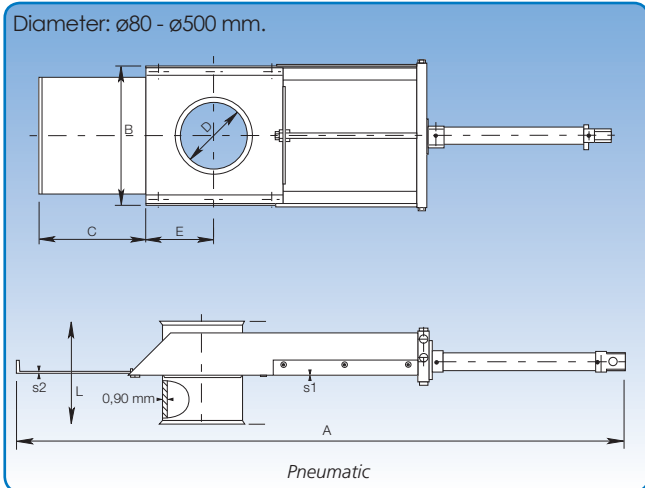

Dimensional specifications for integration length (L) are given in the table below.

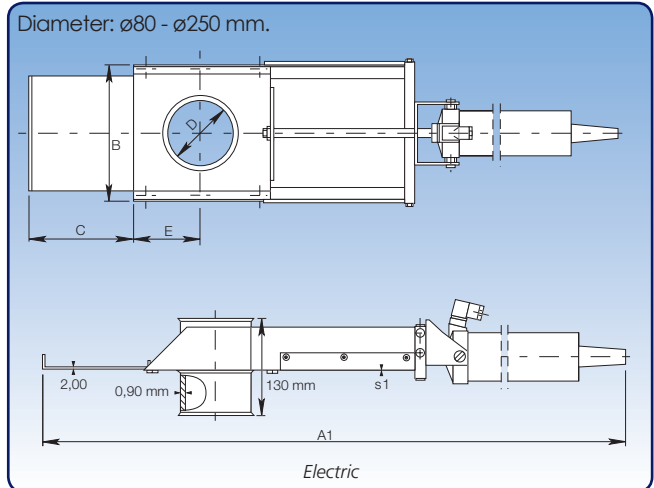

Dimensional specifications for integration length (L) are given in the table below.

General

Sliding dampers are made of 0.90 mm galvanised sheet metal (s) with a damper of 2.00 mm galvanised sheet metal (s2).

Pneumatic pressure: 4-6 bar.

Damper is fitted with a pneumatic cylinder.

Solenoid and setting switches for position indication available as optional extras.

With electric actuator

Damper fitted with a 230 V AC - 50 Hz electric shaft motor.

Dimensions											
Item no. (Pneu.)	Item no. (Elec.)	D mm	s1 mm	A mm	A1 mm	B mm	C mm	C1 mm	E mm	Weight (Pneu.) kg	Weight (Elec.) kg
9251470512	9251470312	80	1,25	550	700	145	105	100	75	3,24	5,20
9251471512	9251471312	100	1,25	800	865	185	150	160	95	4,19	6,20
9251472512	9251472312	120	1,25	800	865	185	150	160	95	4,51	6,43
9251473512	9251473312	125	1,25	800	865	185	150	160	95	4,51	6,27
9251474512	9251474312	140	1,25	975	980	225	175	200	115	5,46	7,41
9251475512	9251470312	150	1,25	975	980	225	175	200	115	5,50	5,50
9251476512	9251476312	160	1,25	975	980	225	175	200	115	5,70	7,50
9251477512	9251477312	180	1,25	1180	1250	295	225	250	150	8,10	9,40
9251478512	9251478312	200	1,25	1180	1250	295	225	250	150	8,60	9,70
9251479512	9251479312	225	1,50	1365	1370	325	270	300	160	9,50	10,60
9251480512	9251480312	250	1,50	1390	1400	350	300	300	175	10,90	11,40
9251480262	-	275	1,50	1725	-	380	325	-	190	12,77	-
9251481512	-	300	1,50	1750	-	400	345	-	205	14,40	-
9251481442	-	315	1,50	1770	-	420	365	-	210	14,90	-
9251482512	-	350	1,50	2000	-	450	435	-	200	16,90	-
9251483512	-	400	1,50	2150	-	500	460	-	250	19,60	-
9251485512	-	450	1,50	2225	-	550	500	-	275	23,90	-
9251486512	-	500	1,50	2575	-	600	550	-	300	27,80	-

The item numbers stated are for sliding dampers assembled using pull rings [f.b].

Sliding dampers are also available for other assembly methods. See p. 6 for assembly methods.

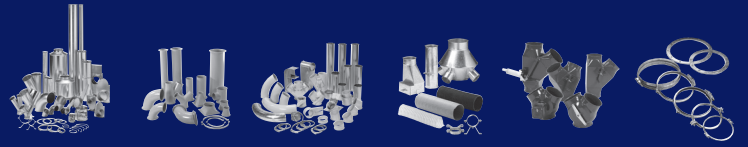

Throttle valves, galvanised, manual, pneumatic and electric

Technical catalogue: Duct systems
 Section: 04
 Page: 6/12
 Revised: 01.05.2009

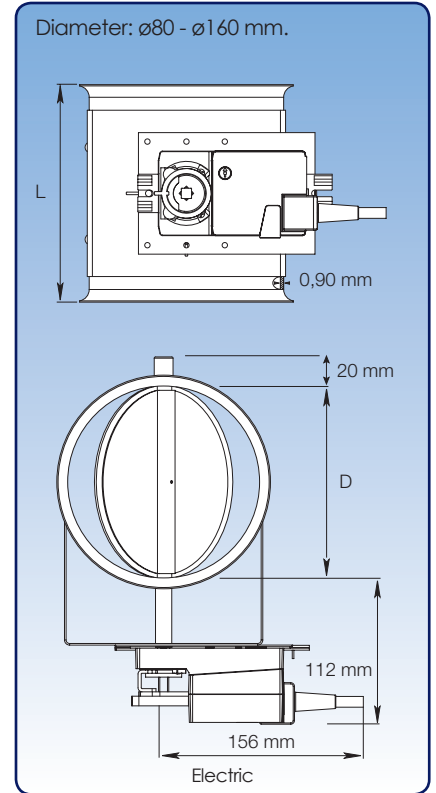
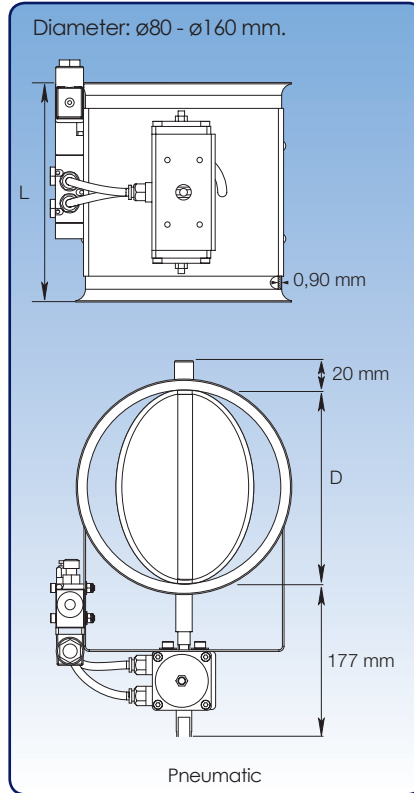
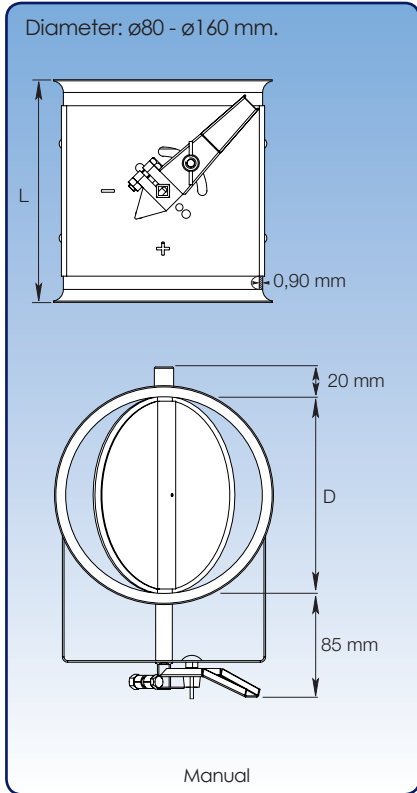

General

Galvanised throttle valves are made of 0.90 mm sheet metal and damper in double sheet. Throttle handle indicates damper position, and can be variably set between open and closed. Available with natural rubber gasket. Maximum closure 96%. Larger throttle valves can be supplied upon request.

With pneumatic actuator

The damper is turned by a pneumatic actuator controlled by an electrically-operated valve. Solenoid valve: monostable 5/2 valve with 1 x 230 V AC - 50/60 Hz electric coil or 24 V DC. Pneumatic pressure: 4-6 bar. Valve setting indicators are available as an optional extra. Solenoid included as standard.

With electric actuator

The damper is operated by an electric motor activated by a changeover switch. Valve setting indicators are available as an optional extra. Electrical connection: 230 V AC - 50 Hz or 24 V DC.

Dimensions							
Item no. (Man.)	Item no. (Pneu.)	Item no. (Elec.)	D mm	L mm	Weight (Man.) kg	Weight (Pneu.) kg	Weight (Elec.) kg
9251510112	9251510412	9251510312	80	125	0,65	1,90	1,60
9251511112	9251511412	9251511312	100	125	0,75	2,00	1,70
9251512112	9251512412	9251512312	120	135	0,90	2,15	1,85
9251513112	9251513412	9251513312	125	135	0,95	2,20	1,90
9251514112	9251514412	9251514312	140	170	1,15	2,40	2,10
9251515112	9251515412	9251515312	150	170	1,25	2,50	2,20
9251516112	9251516412	9251516312	160	170	1,35	2,60	2,30

The item numbers stated are for throttle valves assembled using pull rings [f.b]. Throttle valves are also available for other assembly methods. See p. 6 for assembly methods.

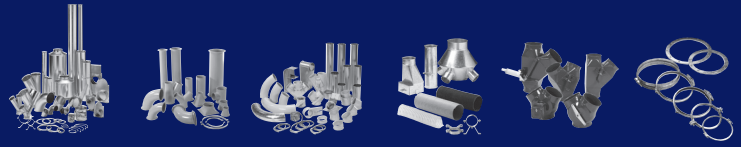

Throttle valves, galvanised, manual, pneumatic and electric

Technical catalogue: Duct systems
 Section: 04
 Page: 7/12
 Revised: 01.05.2009

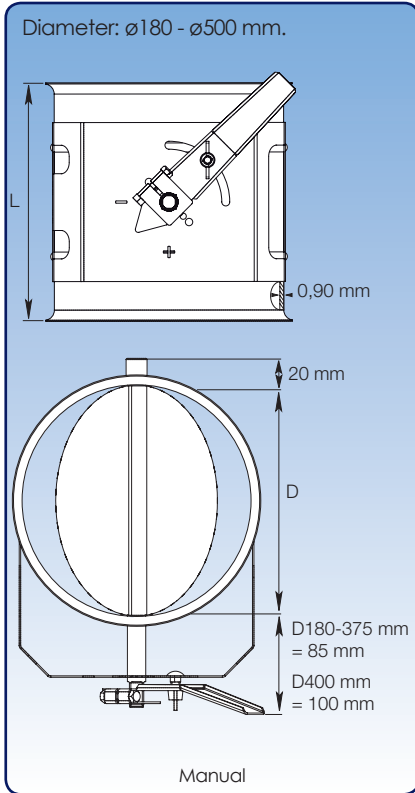

General

Throttle valves are made of 0.90 mm sheet metal and damper in double sheet. Throttle handle indicates damper position, and can be variably set between open and closed. Available with natural rubber gasket. Maximum closure 96%. Larger throttle valves can be supplied upon request.

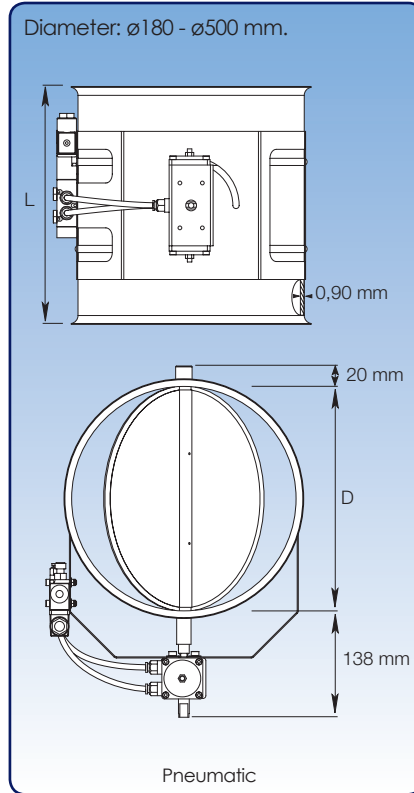

With pneumatic actuator

The damper is turned by a pneumatic actuator controlled by an electrically-operated valve. Solenoid valve: monostable 5/2 valve with 1 x 230 V AC - 50/60 Hz electric coil or 24 V DC. Pneumatic pressure: 4-6 bar. Valve setting indicators are available as an optional extra. Larger throttle valves can be made to order.

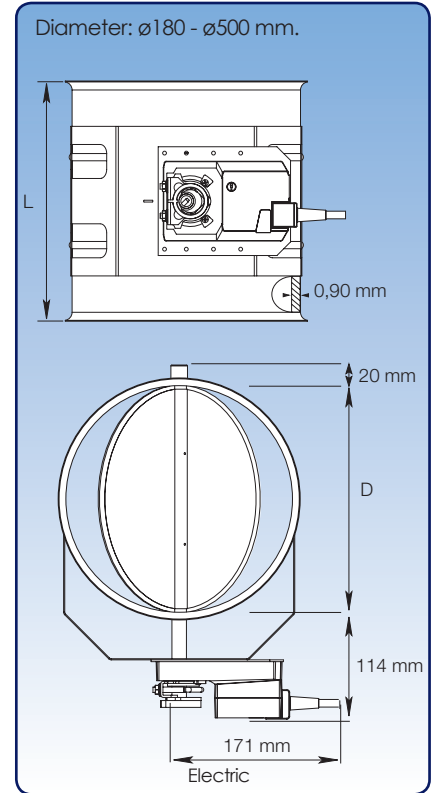

With electric actuator

The damper is operated by an electric motor activated by a changeover switch. Valve setting indicators are available as an optional extra. Electrical connection: 230 V AC - 50 Hz or 24 V DC. Larger throttle valves can be made to order.

Dimensions							
Item no. (Man.)	Item no. (Pneu.)	Item no. (Elec.)	D mm	L mm	Weight (Man.) kg	Weight (Pneu.) kg	Weight (Elec.) kg
9251517112	9251517412	9251517312	180	210	1,90	2,85	3,55
9251518112	9251518412	9251518312	200	210	2,20	3,15	3,85
9251519112	9251519412	9251519312	225	240	2,55	3,60	4,20
9251520112	9251520412	9251520312	250	265	3,05	4,00	5,05
9251520612	9251520812	9251520712	275	290	3,50	4,50	5,50
9251521112	9251521412	9251521312	300	315	4,30	5,20	6,30
9251521612	9251521812	9251521712	315	330	4,30	5,50	6,50
9251522112	9251522412	9251522312	350	365	4,77	6,30	6,50
9251523112	9251523412	9251523312	400	415	5,50	7,60	7,50
9251524112	9251524412	9251524312	450	465	6,10	9,30	9,70
9251525112	9251525412	9251525312	500	515	13,10	11,03	11,45

The item numbers stated are for throttle valves assembled using pull rings [f.b]. Throttle valves are also available for other assembly methods. See p. 6 for assembly methods.

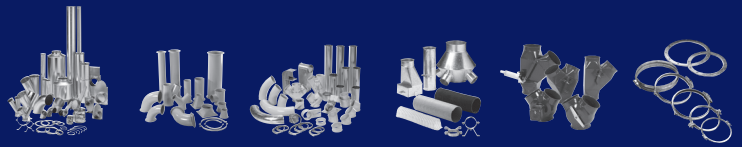

60° branch diverters, pressed, manual, pneumatic and electric

Technical catalogue: Duct systems
 Section: 04
 Page: 8/12
 Revised: 01.05.2009

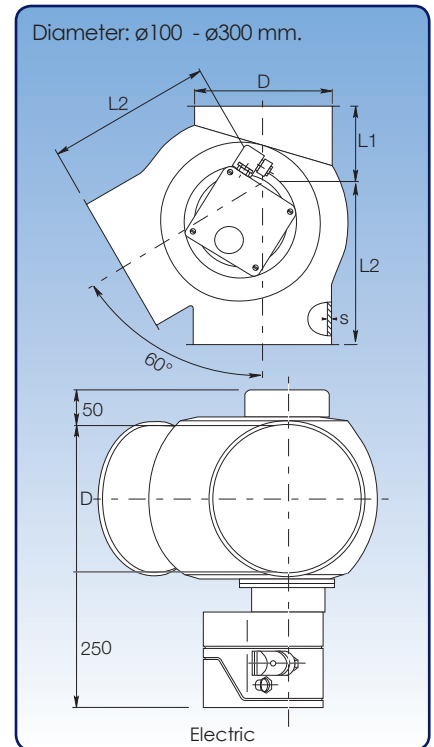
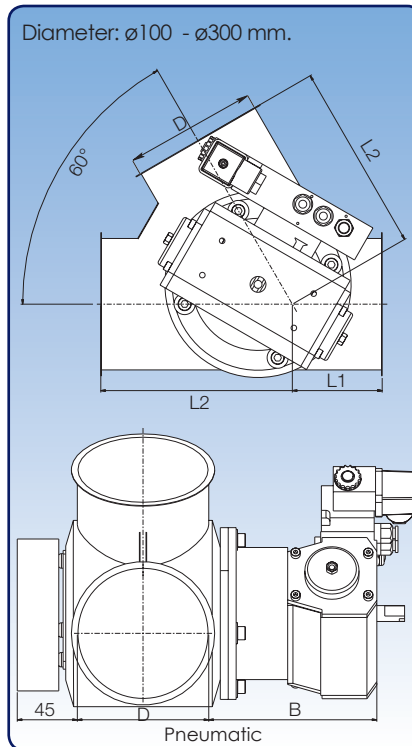
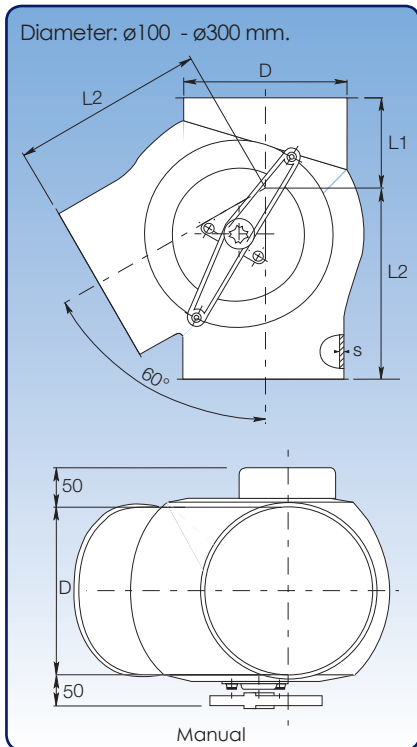

Dimensional specifications are given in the table below.

General

60° branch diverters, pressed, designed for falling and forced direction transport. Damper suspended on brass bearings. Supplied as standard with left branch.

With pneumatic actuator

The damper is turned by a pneumatic actuator controlled by an electrically-operated valve. Solenoid valve: monostable 5/2 valve with 1 x 230 V AC - 50/60 Hz electric coil or 24 V DC. Pneumatic pressure: 4-6 bar. Valve setting indicators are available as an optional extra.

With electric actuator

The damper is operated by an electric motor activated by a changeover switch. Electrical connection: 230 V AC - 50 Hz or 24 V DC. Valve setting indicators are supplied as standard.

Dimensions										
Item no. (Man.)	Item no. (Pneu.)	Item no. (Elec.)	D mm	s mm	B mm	L1 mm	L2 mm	Weight (Man.) kg	Weight (Pneu.) kg	Weight (Elec.) kg
9251700036	9251720036	9251710036	100	1,50	145	70	145	2,20	5,20	6,90
9251701036	9251721036	9251711036	120	1,50	145	160	240	6,00	9,00	10,70
9251702036	9251722036	9251712036	125	1,50	145	90	170	4,00	7,00	8,70
9251703036	9251723036	9251713036	150	2,00	145	100	190	5,70	8,70	10,40
9251704036	9251724036	9251714036	160	2,00	145	95	225	6,10	9,10	10,80
9251705036	9251725036	9251715036	180	2,00	145	195	315	11,00	14,00	15,70
9251706036	9251726036	9251716036	200	2,00	145	110	230	8,30	11,30	13,00
9251707036	9251727036	9251717036	250	2,00	145	135	270	13,10	16,10	17,90
9251708036	9251727336	9251717336	300	2,00	145	160	325	19,30	22,30	24,10

The item numbers stated are for branch diverters assembled using pull rings [f.b]. Branch diverters are also available for other assembly methods. See p. 7 for assembly methods.

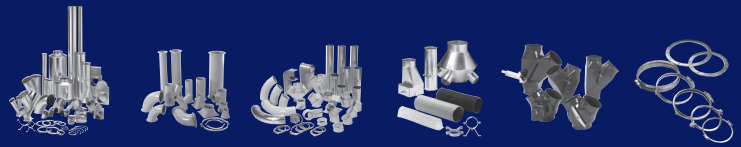

45° branch diverters, pressed, manual

Technical catalogue: Duct systems
 Section: 04
 Page: 9/12
 Revised: 01.05.2009

Suggestion for use of Kongskilde bends.
 Example shows a trouser diverter and two 15° bends.

Pressed diverters are made of 1,50 - 2,00 mm sheet metal (s) with a standard 2,00 mm damper suspended on brass bearings.

Supplied as standard with left branch.

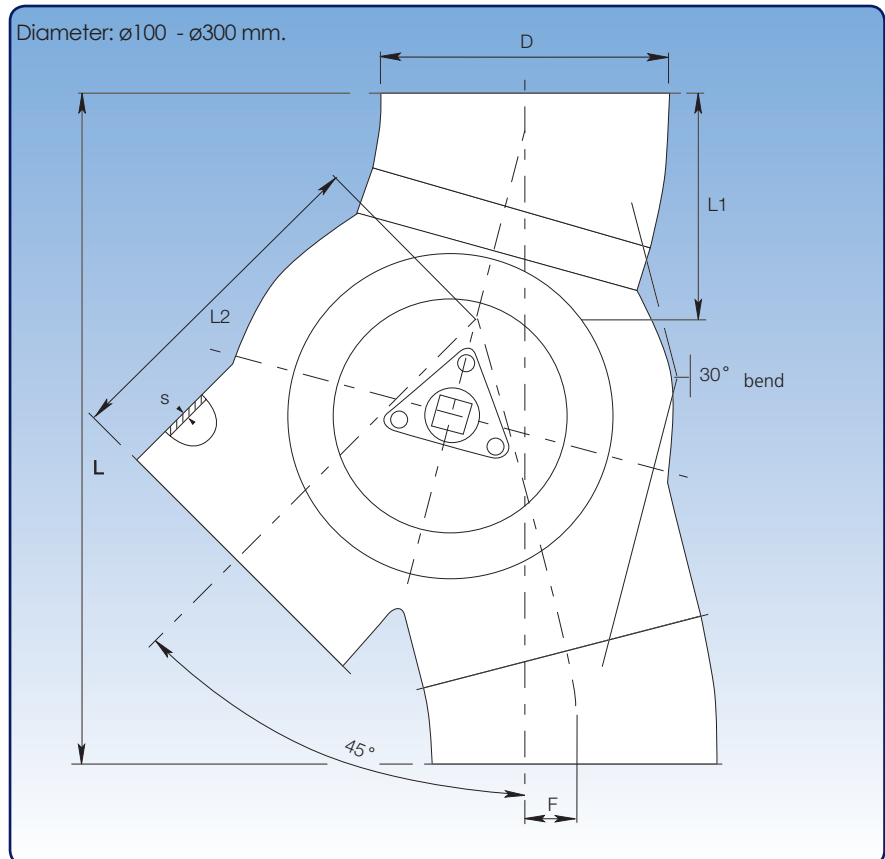

Dimensional specifications are given in the table below.

Dimensions							
D mm	s mm	F mm	L mm	L1 mm	L2 mm	Weight kg	
100	1,50	25	270	100	145	2,80	
120	1,50	25	380	145	240	5,90	
125	1,50	25	335	120	170	5,30	
150	2,00	30	375	135	190	7,80	
160	2,00	40	410	130	225	7,80	
180	2,00	40	600	230	315	13,40	
200	2,00	40	455	155	230	11,30	
250	2,00	35	550	190	270	17,70	
300	2,00	55	660	230	325	25,90	

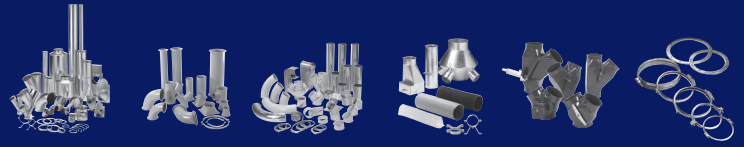

45° branch diverters, welded, manual, pneumatic and electric

Technical catalogue: Duct systems
 Section: 04
 Page: 10/12
 Revised: 01.05.2009

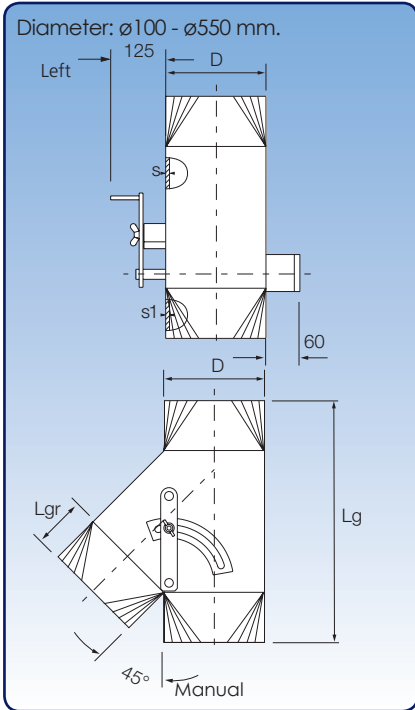

General

Diameter: ø100 - ø550 mm.
 Designed for falling and pneumatic transport. Available with rubber gasket on damper plate for pneumatic transport.
 Damper suspended on nylon bearings.
 Supplied as standard with left branch.

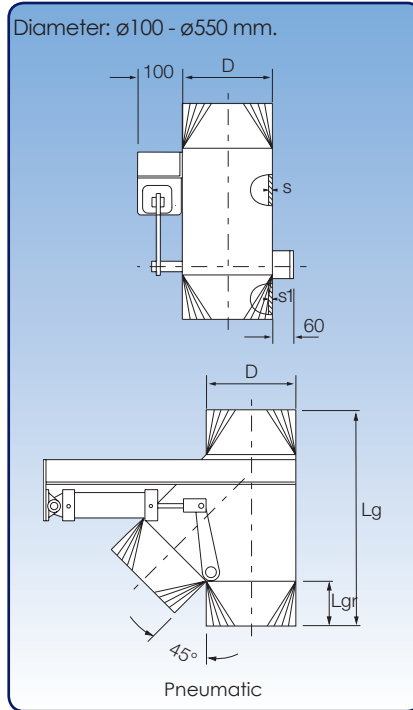

With pneumatic actuator

The damper is turned by a pneumatic cylinder controlled by an electrically-operated valve.
 Solenoid valve: monostable 5/2 valve with 1 x 230 V AC - 50/60 Hz electric coil or 24 V DC. Pneumatic pressure: 4-6 bar. Valve setting indicators are available as an optional extra.

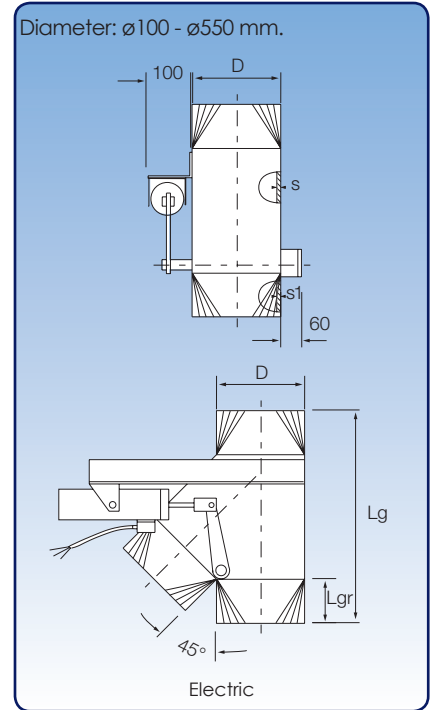

With electric actuator

The damper is operated by an electric motor activated by a changeover switch. Power supply: 230 V AC - 50 Hz. Switch box with damper setting indicators available as an optional extra. Not supplied with profile for damper plate.

Dimensions											
Item no. (Man.)	Item no. (Pneu.)	Item no. (Elec.)	D mm	s mm	s1 mm	Damper plate mm	Lg mm	Lgr mm	Weight (Man.) kg	Weight (Pneu.) kg	Weight (Elec.) kg
9251700064	9251740064	9251710064	100	3,00	2,00	4,00	360	105	2,80	5,80	7,50
9251701064	9251741064	9251711064	120	3,00	2,00	4,00	400	110	5,90	8,90	10,60
9251702064	9251742064	9251712064	125	3,00	2,00	4,00	400	110	5,30	8,30	10,00
9251702164	9251742964	9251712964	140	3,00	2,00	5,00	495	145	7,80	10,80	12,50
9251703064	9251743064	9251713064	150	3,00	2,00	5,00	495	145	7,80	10,80	12,50
9251704064	9251744064	9251714064	160	3,00	2,00	5,00	560	145	7,80	10,80	12,50
9251705064	9251745064	9251715064	180	3,00	2,00	5,00	560	145	13,40	16,40	18,10
9251706064	9251746064	9251716064	200	3,00	2,00	5,00	855	250	11,30	14,30	16,00
9251707064	9251747064	9251717064	250	3,00	2,00	6,00	1000	250	17,70	21,10	22,50
9251708064	9251747364	9251717364	300	4,00	3,00	6,00	1225	295	25,90	29,30	30,70
9251708564	9251747564	9251717564	315	4,00	3,00	6,00	1315	295	27,40	30,80	32,20
9251709064	9251747664	9251717664	350	4,00	3,00	6,00	1315	295	30,00	33,40	34,80
9251709264	9251747964	9251717964	400	4,00	3,00	6,00	1490	345	40,00	43,40	44,80
9251709364	9251748064	9251718064	450	4,00	3,00	6,00	1135	248	45,00	48,40	49,80
9251709464	9251748364	9251718364	500	4,00	3,00	6,00	1205	248	50,00	53,40	54,80
9251709564	9251748664	9251718664	550	4,00	3,00	6,00	1275	248	55,00	58,40	59,80

The item numbers stated are for branch diverters assembled using pull rings [f.b].

Branch diverters are also available for other assembly methods. See p. 7 for assembly methods.

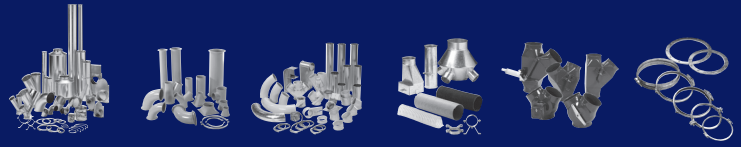

60° trouser diverters, pressed, manual, pneumatic and electric

Technical catalogue: Duct systems
 Section: 04
 Page: 11/12
 Revised: 01.05.2009

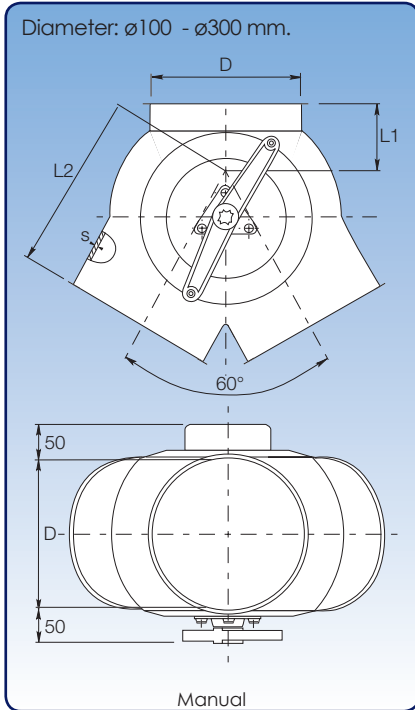

Dimensional specifications are given in the table below.

General

Trouser diverters, welded, are designed for falling and forced direction transport. Pressed diverters are made of 1.50 - 2.00 mm sheet metal (s) with a standard 2.00 mm damper suspended on brass bearings.

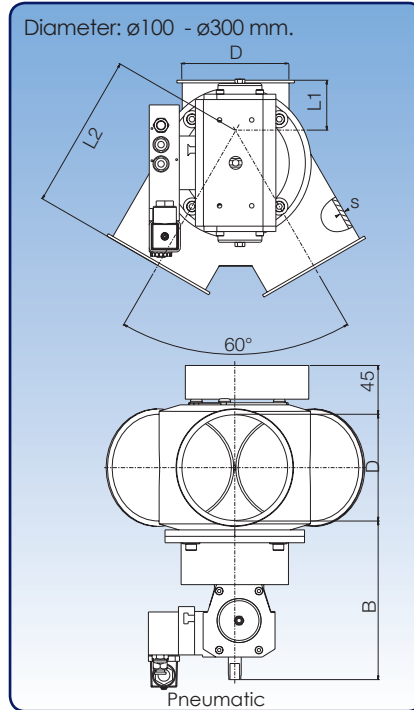

Dimensional specifications are given in the table below.

With pneumatic actuator

The damper is turned by a pneumatic actuator controlled by an electrically-operated valve.
 Solenoid valve: monostable 5/2 valve with 1 x 230 V AC - 50/60 Hz electric coil or 24 V DC. Pneumatic pressure: 4-6 bar. Valve setting indicators are available as an optional extra.

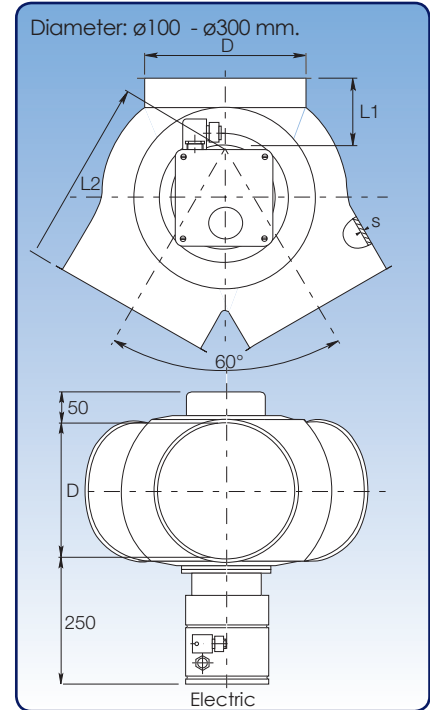

Dimensional specifications are given in the table below.

With electric actuator

The damper is operated by an electric motor activated by a changeover switch.
 Power supply: 230 V AC - 50 Hz or 24 V DC.
 Switch box with damper setting indicators supplied as standard.
 Not supplied with profile for damper plate.

Dimensions										
Item no. (Man.)	Item no. (Pneu.)	Item no. (Elec.)	D mm	s mm	B mm	L1 mm	L2 mm	Weight (Man.) kg	Weight (Pneu.) kg	Weight (Elec.) kg
9251700037	9251720037	9251710037	100	1,50	145	70	145	2,00	5,00	6,70
9251701037	9251721037	9251711037	120	1,50	145	160	240	4,70	7,80	9,40
9251702037	9251722037	9251712037	125	1,50	145	90	170	3,90	6,90	8,60
9251703037	9251723037	9251713037	150	2,00	145	100	190	5,60	8,80	10,50
9251704037	9251724037	9251714037	160	2,00	145	95	225	5,60	8,50	10,30
9251705037	9251725037	9251715037	180	2,00	145	195	315	10,60	13,70	15,30
9251706037	9251726037	9251716037	200	2,00	145	110	230	7,90	10,90	12,60
9251707037	9251727037	9251717037	250	2,00	185	135	270	12,50	15,50	17,30
9251708037	9251727337	9251717337	300	2,00	185	160	325	18,25	21,30	23,10

The item numbers stated are for trouser diverters assembled using pull rings [f.b].
 Trouser diverters are also available for other assembly methods. See p. 7 for assembly methods.

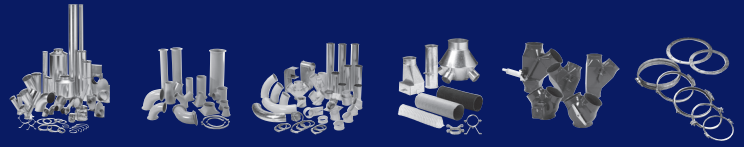

60° trouser diverters, welded, manual, pneumatic and electric

Technical catalogue: Duct systems
 Section: 04
 Page: 12/12
 Revised: 01.05.2009

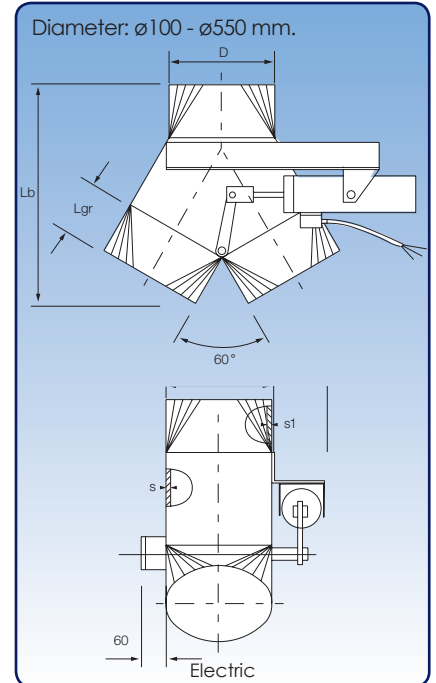
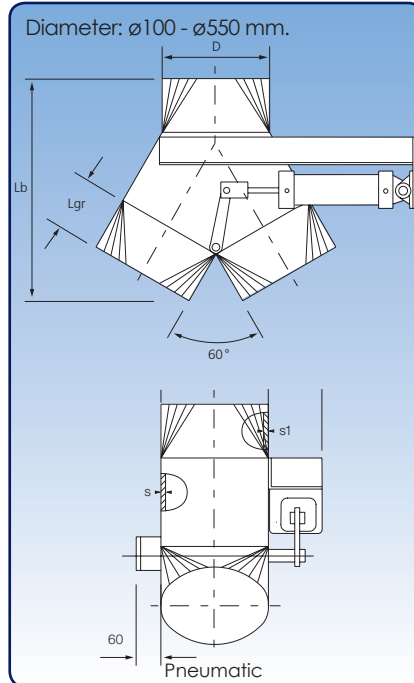
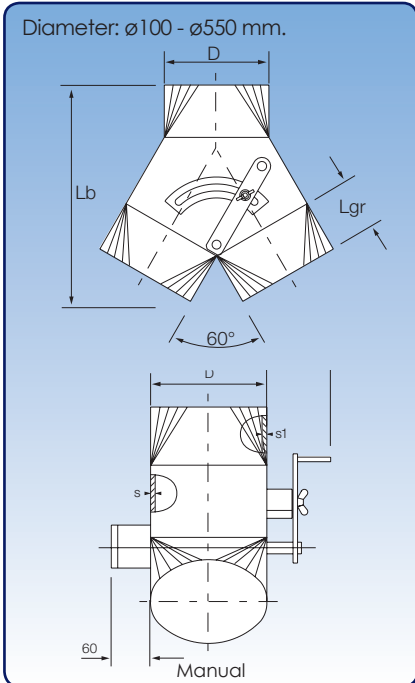

Dimensional specifications are given in the table below.

General

Trouser diverters, welded, manual, are designed for falling and pneumatic transport. Available with rubber gasket on damper plate for pneumatic transport.

With pneumatic actuator

The damper is turned by a pneumatic cylinder controlled by an electrically-operated valve. Solenoid valve: monostable 5/2 valve with 1 x 230 V AC - 50/60 Hz electric coil or 24 V DC. Pneumatic pressure: 4-6 bar. Valve setting indicators are available as an optional extra.

With electric actuator

The damper is operated by an electric motor activated by a changeover switch. Power supply: 230 V AC - 50 Hz. Switch box with damper setting indicators available as an optional extra.

Dimensions												
Item no. (Man.)	Item no. (Pneu.)	Item no. (Elec.)	D mm	s mm	s1 mm	S2 mm	Lb mm	Lgr mm	Weight (Man.) kg	Weight (Pneu.) kg	Weight (Elec.) kg	
9251700067	9251720067	9251710067	100	3,00	2,00	4,00	305	105	2,00	6,70	6,70	
9251701067	9251721067	9251711067	120	3,00	2,00	4,00	330	110	4,70	7,80	9,40	
9251702067	9251722067	9251712067	125	3,00	2,00	4,00	330	110	3,90	6,90	8,60	
9251702167	9251722967	9251712967	140	3,00	2,00	5,00	455	145	5,80	10,50	10,50	
9251703067	9251723067	9251713067	150	3,00	2,00	5,00	455	145	5,80	8,80	10,50	
9251704067	9251724067	9251714067	160	3,00	2,00	5,00	455	145	5,60	9,00	10,30	
9251705067	9251725067	9251715067	180	3,00	2,00	5,00	525	145	10,60	13,70	15,30	
9251706067	9251726067	9251716067	200	3,00	2,00	5,00	525	145	11,30	10,90	12,60	
9251706967	9251746967	9251716967	225	3,00	2,00	5,00	820	250	12,50	12,60	23,10	
9251707067	9251727067	9251717067	250	3,00	2,00	5,00	820	250	12,50	15,90	17,30	
9251707267	9251727267	9251717267	275	3,00	2,00	5,00	900	250	18,30	21,70	23,10	
9251708067	9251727367	9251717367	300	3,00	2,00	5,00	900	250	18,30	21,70	23,10	
9251708567	9251747567	9251717567	315	3,00	2,00	6,00	880	250	19,60	22,00	24,40	
9251709067	9251727667	9251717667	350	3,00	2,00	6,00	880	250	24,00	27,40	28,80	
9251709267	9251727967	9251717967	400	3,00	2,00	6,00	930	295	37,00	37,00	36,80	
9251709367	9251728067	9251718067	450	4,00	3,00	6,00	965	295	37,00	40,00	41,80	
9251709467	9251728367	9251718367	500	4,00	3,00	6,00	1040	295	42,00	45,00	46,80	
9251709567	9251728667	9251718667	550	4,00	3,00	6,00	1170	345	48,00	51,00	52,80	

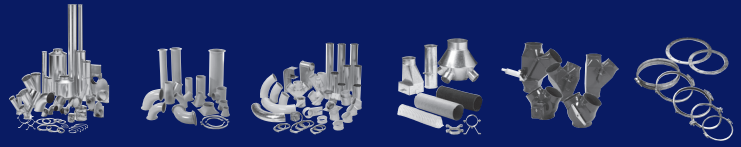

Pull rings, galvanised

Technical catalogue: Duct systems
 Section: 05
 Page: 1/2
 Revised: 01.05.2009

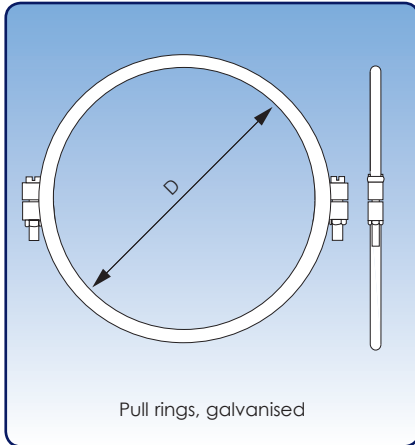

Pull rings, galvanised

Diameter: $\varnothing 80 - \varnothing 500$ mm.
 Galvanised pull rings [f.b] are in two pieces. Pull rings are electro-galvanised. EPDM rubber rings are available as optional extras for sealing $\varnothing 80 - \varnothing 300$ mm diameter assemblies.

They are supplied in plastic bags of 10, along with the necessary nuts and bolts.

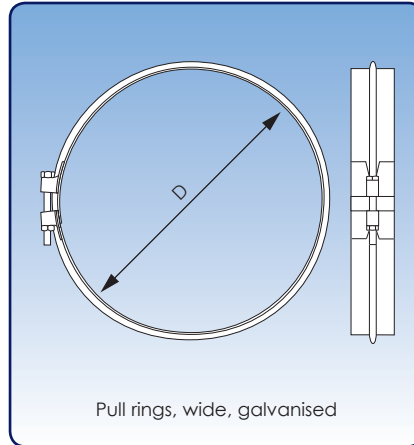

Pull rings, wide, galvanised

Diameter: $\varnothing 150 - \varnothing 800$ mm.
 Wide galvanised pull rings [f.bb] are made from hot dip galvanised sheet metal.

These rings are supplied individually with nuts and bolts.

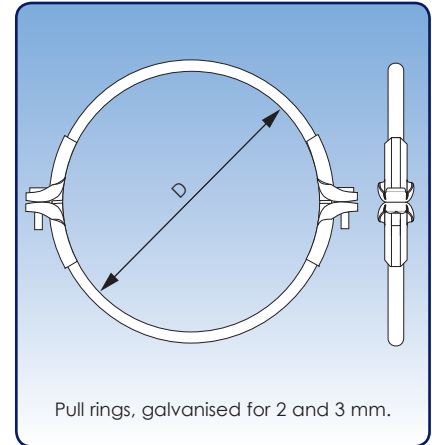

Pull rings, galvanised for 2 and 3 mm.

Diameter: $\varnothing 80 - \varnothing 600$ mm.
 Galvanised pull rings [f.b] are in two pieces. Pull rings are electro-galvanised.

Insert with sealing compound

Kongskilde supplies pull rings with sealing compound inserted, made of Terostat Vll material. The insert has a protective plastic film which must be removed before the pull ring can be used. The sealing compound is not soluble. Working temperature range is -50°C to $+100^{\circ}\text{C}$. The rings are supplied in plastic bags of 10, along with the necessary nuts and bolts.

Pull rings, galv.		
Item no.	D mm	10 pcs. Weight kg
9251670011	80	0,55
9251671011	100	0,60
9251672011	120	0,65
9251673011	125	0,70
9251674011	140	0,75
9251675011	150	0,80
9251676011	160	0,83
9251677011	180	0,85
9251678011	200	0,90
9251679011	225	0,95
9251680011	250	1,00
9251680511	275	1,05
9251681011	300	1,25
9251682011	315	1,30
9251682611	325	1,30
9251683011	350	1,35
9251684011	400	1,45
9251684711	425	1,50
9251685011	450	1,65
9251686011	500	1,90

Pull rings, wide, galvanised.		
Item no.	D mm	Pce. Weight kg
9251675001	150	0,22
9251676001	160	0,23
9251677001	180	0,24
9251678001	200	0,25
9251679001	225	0,30
9251680001	250	0,35
9251680501	275	0,40
9251681001	300	0,45
9251682001	315	0,47
9251682601	325	0,49
9251683001	350	0,50
9251683701	375	0,52
9251684001	400	0,55
9251684701	425	0,55
9251685001	450	0,60
9251685901	475	0,60
9251686001	500	0,65
9251686501	525	0,67
9251687001	550	0,70
9251688001	600	0,75
9251689001	630	0,78
9251690001	650	0,80
9251691001	700	0,86
9251692001	750	0,90
9251693001	800	0,98

Pull rings, 2 and 3 mm, galv.		
Item no.	D mm	10 pcs. Weight kg
Rubber ring insert (EPDM)		
9251670021	80	1,76
9251671021	100	1,87
9251672021	120	2,04
9251673021	125	2,21
9251674021	140	2,25
9251675021	150	2,38
9251676021	160	2,55
9251677021	180	2,72
9251678021	200	2,83
9251679021	225	3,20
9251680021	250	3,40
9251680521	275	3,45
9251681021	300	3,57
Insert with sealing compound		
9251682021	315	4,25
9251683021	350	4,42
9251684021	400	4,93
9251685021	450	5,61
9251686021	500	6,46
9251687021	550	7,14
9251688021	600	8,50

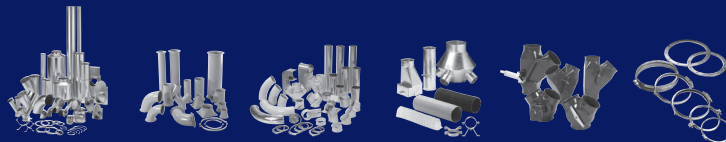

Rubber gasket rings

Technical catalogue: Duct systems
 Section: 05
 Page: 2/2
 Revised: 01.05.2009

Diameter: $\varnothing 80 - \varnothing 300$ mm.

Standard rubber gasket rings are made of EPDM 80 rubber and used for f.b. assemblies to improve degree of tightness.

One ring is fitted for each assembly.
 Rings are fitted on either f.b. edge before assembly.

Rubber gasket rings are U-shaped in cross section.
 Hardness is 80 shore, and working temperature range is -40°C to $+100^{\circ}\text{C}$.

Same dimensions are available in NITRIL rubber.
 Hardness is 80 shore, and working temperature range is -15°C to $+80^{\circ}\text{C}$.

NITRIL rubber is resistant to oil and petrol, and to some degree to acids and bases.

Supplied in plastic bags of 10 pcs.

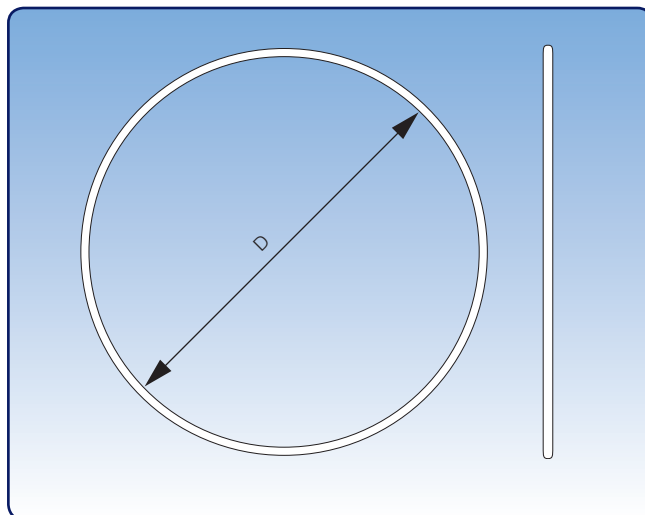

Dimensional specifications are given in the table below.

Item no.	Dimensions	
	D mm	Weight/10 pcs. kg
925820170080	80	0,20
925820170100	100	0,30
925820170120	120	0,50
925820170125	125	0,50
925820170140	140	0,60
925820170150	150	0,60
925820170160	160	0,70
925820170180	180	0,70
925820170200	200	0,80
925820170225	225	1,10
925820170250	250	1,12
925820170275	275	1,12
925820170300	300	1,30

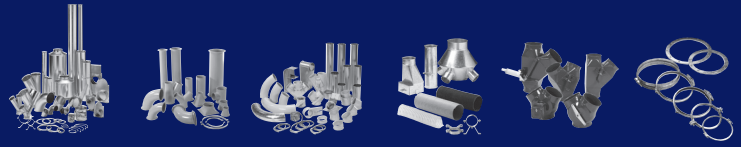

Rapid lock pull rings, galvanised

Technical catalogue: Duct systems
 Section: 06
 Page: 1/1
 Revised: 01.05.2009

Rapid lock pull rings [f.lyn] are electro-galvanised and used for fast, tight assembly of duct systems.

Fitted with an insert which provides a dust-resistant joint and provides stability to the duct system, ensuring electrical conductivity through the assembly.

2 and 3 mm duct systems are fitted with a rapid lock pull ring with an insert which facilitates a larger size.

A silicon insert is required for temperatures above 80°C, which can tolerate temperatures up to 275°C.

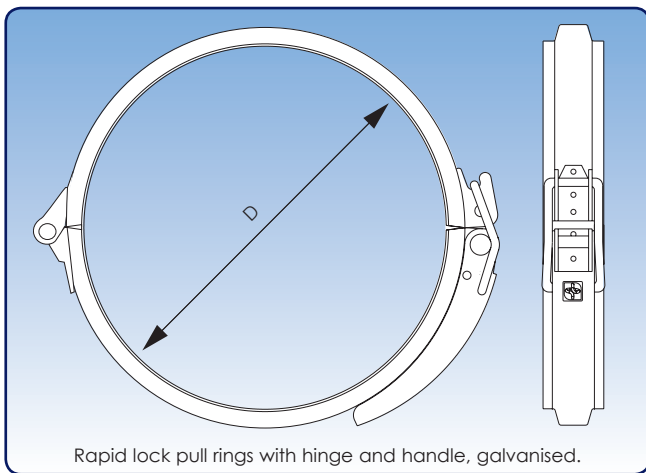

Rapid lock pull rings with hinge and handle, galvanised.

Diameter: $\varnothing 80 - \varnothing 425$ mm.

Handle is extended and made of a strong material for hand operation of rapid lock pull rings.

The powerful steel spring ensures high quality opening/closing mechanism and long service life.

Supplied individually.

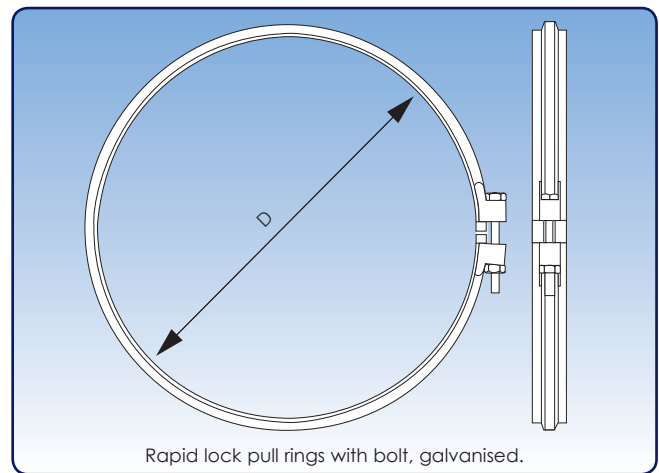

Rapid lock pull rings with bolt, galvanised.

Diameter: $\varnothing 450 - \varnothing 600$ mm

Supplied individually with nuts and bolts.

Rapid lock pull rings with hinge and handle, galvanised.

Item no.	D mm	Weight kg
9251670012	80	1,90
9251671012	100	2,10
9251672012	120	2,30
9251673012	125	2,40
9251674012	140	2,50
9251675012	150	2,60
9251676012	160	2,80
9251677012	180	3,00
9251678012	200	3,20
9251679012	225	3,40
9251680012	250	3,70
9251680512	275	3,90
9251681012	300	4,20

Item no.	D mm	Weight kg
9251682012	315	4,40
9251682612	325	4,50
9251683012	350	4,80
9251683612	355	4,80
9251683712	375	5,10
9251684012	400	5,30
9251684712	425	5,60

Rapid lock pull rings with bolt, galvanised.

9251685012	450	5,80
9251685912	475	6,10
9251686012	500	6,30
9251687012	550	6,80
9251688012	600	7,30

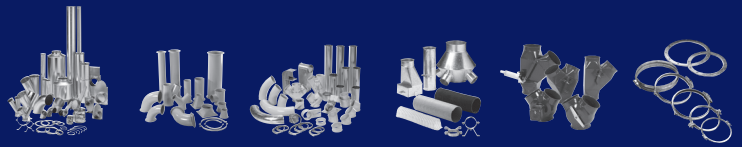

Flanges

Technical catalogue: Duct systems
 Section: 07
 Page: 1/2
 Revised: 01.05.2009

Diameter: $\varnothing 80 - \varnothing 1250$ mm.
 Flanges are made in accordance with Kongskilde's standard, and are a standard component in the product range.

Flanges are stock items in hot dip galvanized finish, but can be supplied either untreated or painted.

Flanges in other dimensions or profiles are available to order.

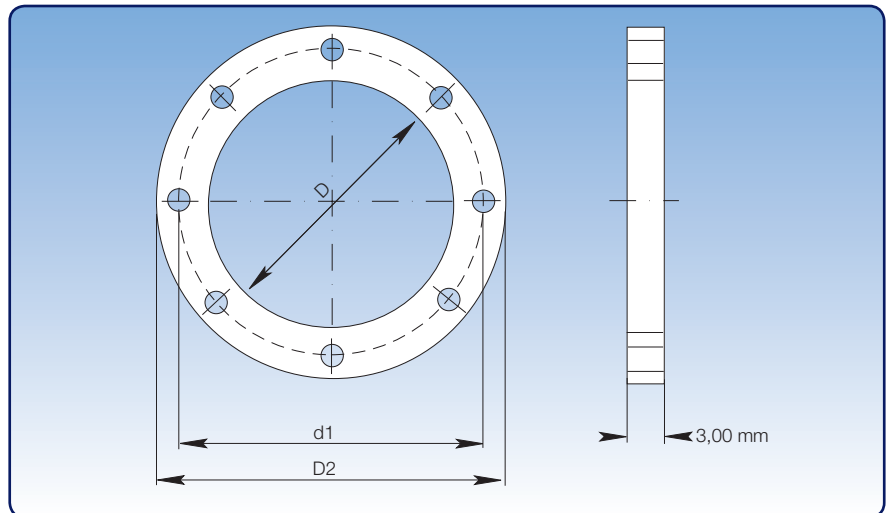

Dimensional specifications are given in the table below.

Item no.	Dimensions								
	Diameter: nominal	D mm	d1 mm	D2 mm	s mm	Flange width mm	Hole size mm	Quant. holes	Weight kg
9251670005	80	83	115	133	3,00	25	9	8	0,26
9251671005	100	103	135	153	3,00	25	9	8	0,31
9251672005	120	123	155	173	3,00	25	9	8	0,36
9251673005	125	128	160	178	3,00	25	9	8	0,38
9251674005	140	143	175	193	3,00	25	9	8	0,41
9251675005	150	155	185	205	5,00	25	9	8	0,55
9251676005	160	165	195	215	5,00	25	9	8	0,58
9251677005	180	185	215	235	5,00	25	9	8	0,64
9251678005	200	205	235	255	5,00	25	9	12	0,70
9251679005	225	230	260	280	5,00	25	9	12	0,75
9251680005	250	255	285	305	5,00	25	9	12	0,85
9251680505	275	280	310	330	5,00	25	9	12	0,96
9251681005	300	305	336	355	5,00	25	9	12	1,01
9251682005	315	320	351	370	5,00	25	9	12	1,26
9251683505	325	330	360	380	5,00	25	9	12	1,38
9251683005	350	355	389	415	6,00	26	11	12	1,64
9251684505	375	380	424	440	6,00	30	11	12	1,77
9251684005	400	405	439	465	6,00	30	11	16	1,85
9251685505	425	430	462	490	6,00	30	11	16	1,96
9251685005	450	455	389	515	6,00	30	11	16	2,04
9251686505	475	480	515	540	6,00	30	11	16	2,18
9251686005	500	505	540	565	6,00	30	11	16	2,30
9251687005	550	555	590	615	6,00	30	11	16	2,50
9251688005	600	605	640	665	6,00	30	11	16	2,80
9251689005	630	635	670	695	6,00	30	11	24	2,90
9251690005	650	655	690	715	6,00	30	11	24	3,00
9251691005	700	705	750	785	6,00	40	11	24	4,30
9251692005	750	755	800	835	6,00	40	11	24	4,50
9251693005	800	805	850	885	6,00	40	11	24	4,90
9251694005	850	855	900	935	6,00	40	11	24	5,20
9251695005	900	905	950	985	6,00	40	11	24	5,50
9251696005	950	955	1000	1035	6,00	40	11	24	5,80
9251697005	1000	1005	1050	1085	6,00	40	11	24	6,00
9251698005	1250	1255	1300	1335	6,00	40	11	28	7,50

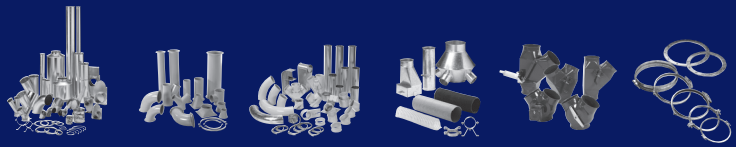

Rubber flanges

Technical catalogue: Duct systems
 Section: 07
 Page: 2/2
 Revised: 01.05.2009

Diameter: $\varnothing 80 - \varnothing 1250$ mm.

Rubber flanges are made of NITRIL rubber, adapted to Kongskilde's standard flange range.

Hardness: 65 shore.
 Temperature range: -10°C to $+70^{\circ}\text{C}$.
 Resistant to oil and petrol and to a limited extent acid and base chemicals.

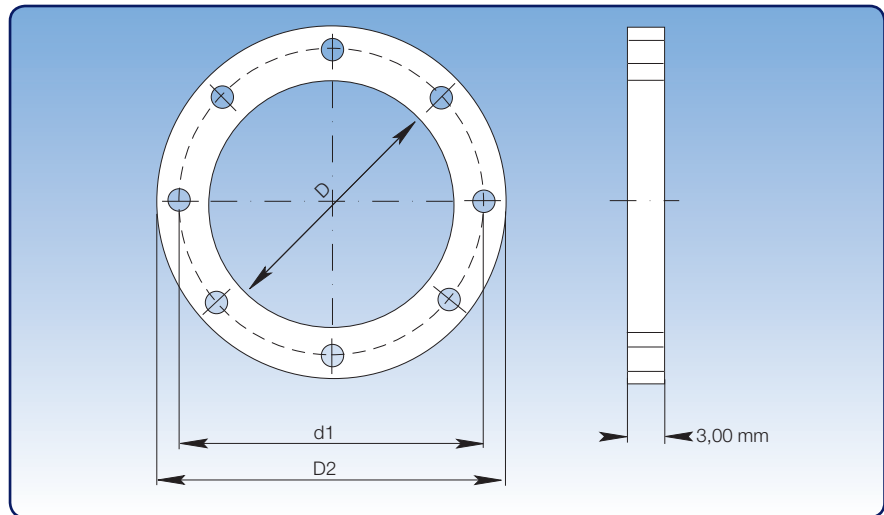

Dimensional specifications are given in the table below.

Item no.	Dimensions						Quant. holes	Weight kg
	Diameter nominal	D mm	d1 mm	D2 mm	Flange width mm	Hole size mm		
925820150080	80	83	115	133	25	8	8	0,02
925820150100	100	103	135	153	25	8	8	0,03
925820150120	120	123	155	173	25	8	8	0,04
925820150125	125	128	160	178	25	8	8	0,05
925820150140	140	143	175	193	25	8	8	0,05
925820150150	150	155	185	205	25	8	8	0,06
925820150160	160	165	195	215	25	8	8	0,06
925820150180	180	185	215	235	25	8	8	0,07
925820150200	200	205	235	255	25	8	12	0,08
925820150225	225	230	260	280	25	8	12	0,09
925820150250	250	255	285	305	25	8	12	0,10
925820150275	275	280	310	330	25	8	12	0,10
925820150300	300	305	336	355	25	8	12	0,11
925820150315	315	320	351	370	25	8	12	0,13
925820150350	350	355	389	415	26	10	12	0,15
925820150400	400	405	439	465	30	10	16	0,18
925820150450	450	455	389	515	30	10	16	0,21
925820150500	500	505	540	565	30	10	16	0,22
925820150550	550	555	590	615	30	10	16	0,25
925820150600	600	605	640	665	30	10	16	0,29
925820150630	630	635	670	695	30	10	24	0,33
925820150650	650	655	690	715	30	10	24	0,35
925820150700	700	705	750	785	40	10	24	0,38
925820150750	750	755	800	835	40	10	24	0,41
925820150800	800	805	850	885	40	10	24	0,49
925820150850	850	855	900	935	40	10	24	0,52
925820150900	900	905	950	985	40	10	24	0,54
925820150950	950	955	1000	1035	40	10	24	0,55
925820151000	1000	1005	1050	1085	40	10	24	0,56
925820151100	1100	1105	1150	1185	40	10	24	0,59
925820151200	1200	1205	1250	1285	40	10	24	0,61
925820151250	1250	1255	1300	1335	40	10	28	0,62

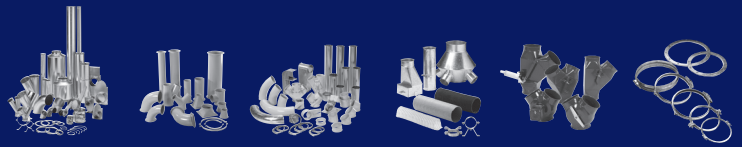

Jet caps, galvanised

Technical catalogue: Duct systems
 Section: 08
 Page: 1/3
 Revised: 01.05.2009

Diameter: \varnothing 120 - \varnothing 1000 mm.

Supplied with the same Kongskilde assembly methods as duct systems.

Jet caps from diameter \varnothing 700 - \varnothing 1000 mm are fitted with flanges as standard.

Jet caps are fitted with an internal cone and drain hose for disposal of water.

See next page for pressure loss curves.

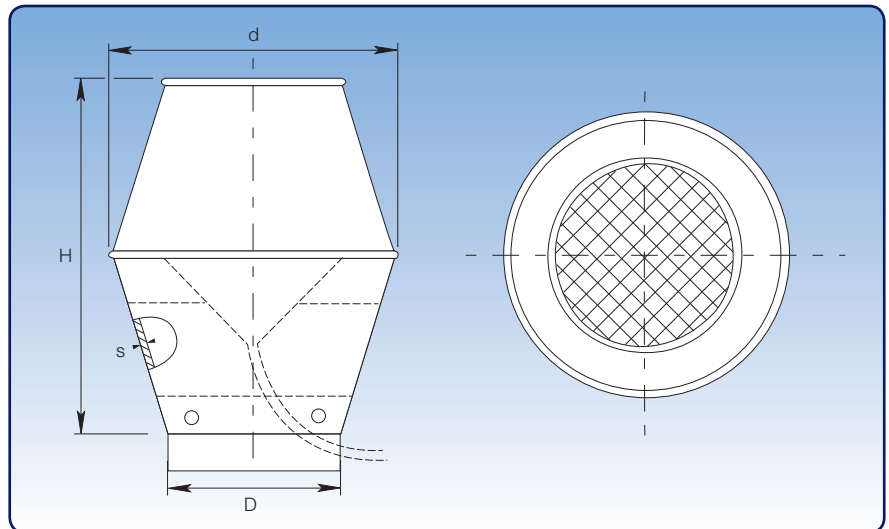

Dimensional specifications are given in the table below.

Dimensions						
Item no.	D mm	d mm	s mm	H mm	Weight kg	
9251902202	120	185	0,75	325	3,00	
9251903202	125	195	0,75	340	3,50	
9251904202	140	215	0,75	365	3,80	
9251905202	150	230	0,90	390	4,00	
9251906202	160	245	0,90	410	5,00	
9251907202	180	275	0,90	445	5,40	
9251908202	200	305	0,90	490	4,00	
9251909202	225	345	0,90	535	4,80	
9251910202	250	380	0,90	590	5,70	
9251912202	275	420	0,90	640	9,00	
9251913202	300	460	0,90	690	8,00	
9251914202	315	480	0,90	720	8,70	
9251915202	350	535	0,90	785	10,70	
9251916202	400	610	0,90	885	13,50	
9251917202	450	690	0,90	985	16,70	
9251918202	500	765	0,90	1095	21,00	
9251919202	550	840	0,90	1200	28,00	
9251920202	600	915	0,90	1300	36,00	
9251921202	630	960	0,90	1360	40,00	
9251922202	650	990	0,90	1390	42,00	
9251923202	700	1070	1,25	1505	49,00	
9251924202	750	1145	1,25	1595	56,00	
9251925202	800	1220	1,25	1695	68,00	
9251926202	850	1295	1,25	1795	80,00	
9251927202	900	1375	1,25	1900	100,00	
9251928202	950	1450	1,25	1975	105,60	
9251929202	1000	1525	1,25	2000	150,00	

Item numbers designated with $D \leq 650$ mm are for jet caps assembled with wide pull rings [f.lyn]. Jet caps are also available for other assembly methods. See p. 6 for assembly methods.

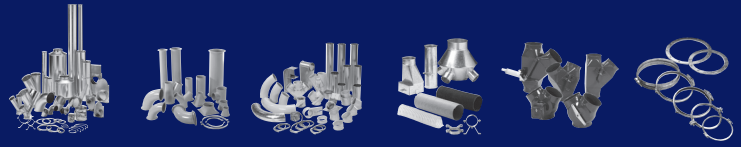

Jet caps, galvanised

Technical data

Technical catalogue: Duct systems
 Section: 08
 Page: 2/3
 Revised: 01.05.2009

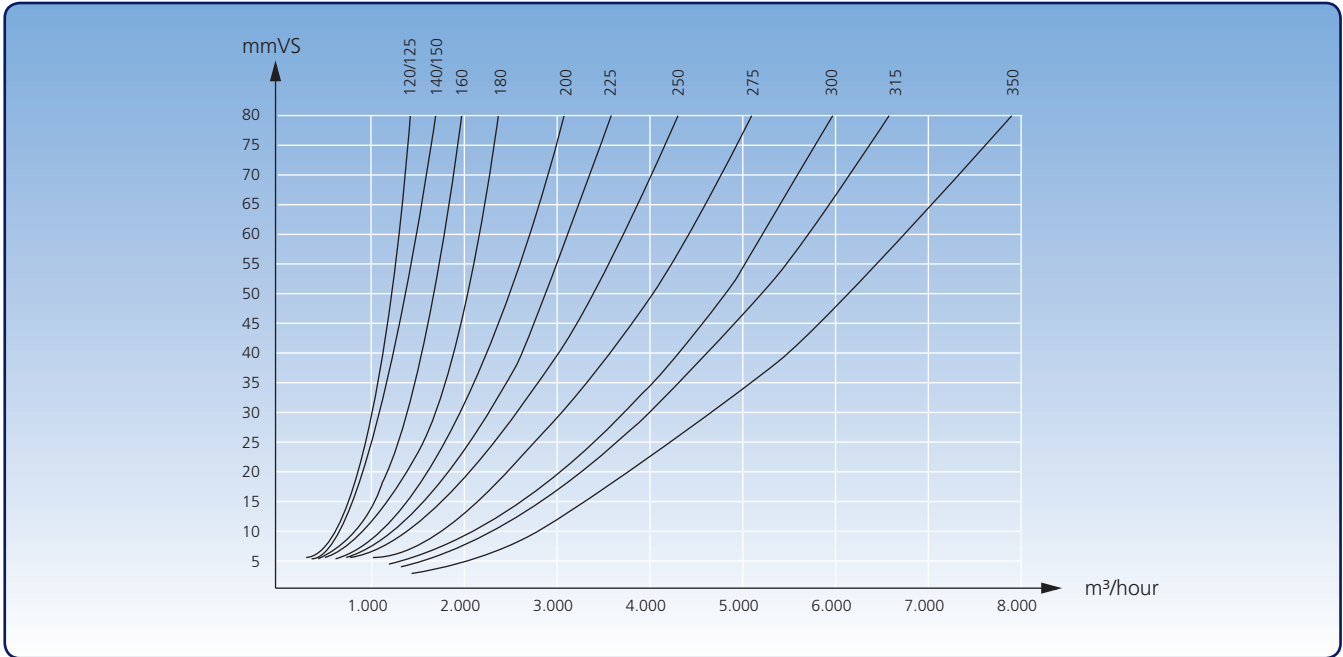

Pressure loss curves for diameter $\varnothing 120 - \varnothing 350$ mm.

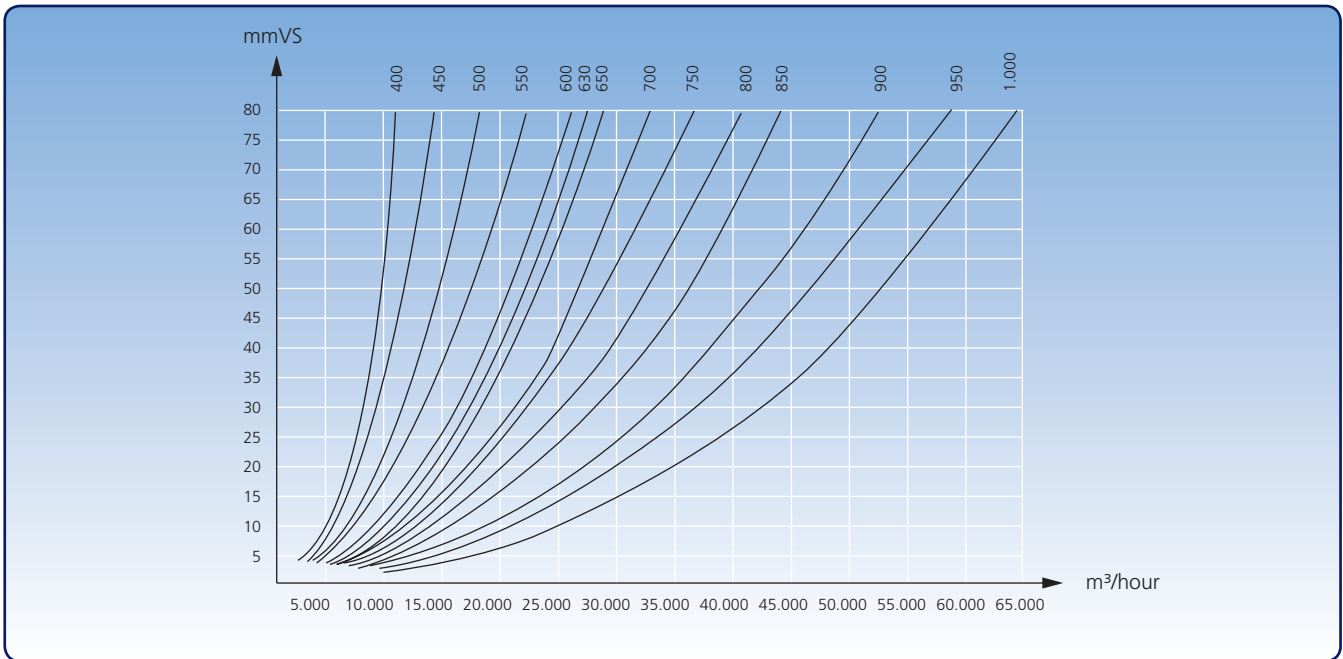

Pressure loss curves for diameter $\varnothing 400 - \varnothing 1000$ mm.

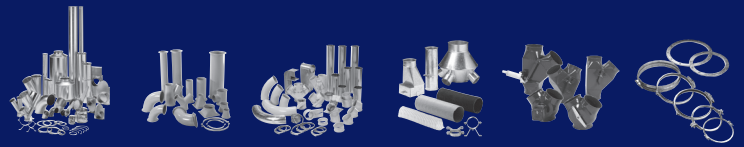

Rain caps, galvanised

Technical catalogue: Duct systems
 Section: 08
 Page: 3/3
 Revised: 01.05.2009

Diameter: $\varnothing 80 - \varnothing 1250$ mm.

Supplied with the same Kongskilde assembly methods as duct systems.

Rain caps from diameter $\varnothing 700 - \varnothing 1000$ mm are fitted with flanges as standard.

Rain caps of diameter $\varnothing 80 - \varnothing 225$ mm are supplied with a skirt and from $\varnothing 250 - \varnothing 1000$ mm with skirt and internal cone.

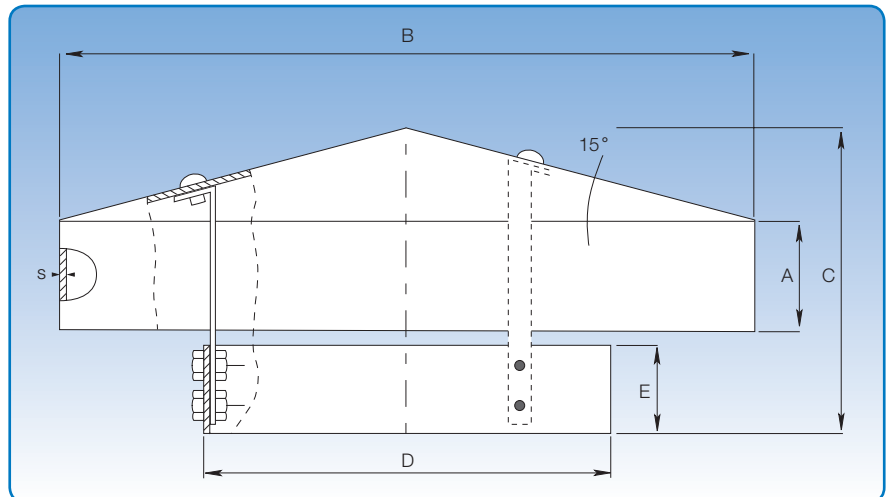

Dimensional specifications are given in the table below.

Dimensions							
Item no.	D mm	s mm	B mm	C mm	A mm	E mm	Weight kg
9251970122	80	0,90	200	130	50	75	1,30
9251971122	100	0,90	200	130	50	75	1,35
9251972122	120	0,90	250	150	50	75	1,40
9251973122	125	0,90	250	150	50	75	1,50
9251974122	140	0,90	350	190	50	100	1,90
9251975122	150	0,90	350	190	50	100	2,20
9251976122	160	0,90	350	190	50	100	2,40
9251977122	180	0,90	400	220	50	100	2,66
9251978122	200	0,90	400	220	50	100	4,00
9251979122	225	0,90	500	240	50	100	5,30
9251980122	250	0,90	500	240	50	100	5,90
9251980162	275	0,90	500	240	50	100	6,00
9251981122	300	0,90	650	340	100	150	6,10
9251982122	315	0,90	650	340	100	150	6,12
9251983122	350	0,90	650	340	100	150	6,14
9251984122	400	0,90	750	371	100	150	6,30
9251985122	450	0,90	750	370	100	150	7,00
9251986122	500	0,90	950	440	150	150	9,70
9251987122	550	0,90	950	440	150	150	9,70
9251988122	600	0,90	1050	480	150	150	12,00
9251989122	630	0,90	1050	480	150	150	10,40
9251990122	650	0,90	1050	480	150	150	11,00
9251991122	700	0,90	1200	570	200	200	19,20
9251992122	750	0,90	1200	570	200	200	20,90
9251993122	800	1,25	1400	610	200	200	22,30
9251994122	850	1,25	1400	610	200	200	26,90
9251995122	900	1,25	1550	680	250	200	29,70
9251996122	950	1,25	1550	680	250	200	31,35
9251997122	1000	1,25	1700	720	250	200	34,50
9251998122	1100	1,25	1850	745	250	200	38,00
9251999122	1250	1,25	2000	765	250	200	43,20

The item numbers stated are for rain caps assembled using wide pull rings [f.lyn]. Rain caps are also available for other assembly methods. See p. 6 for assembly methods.

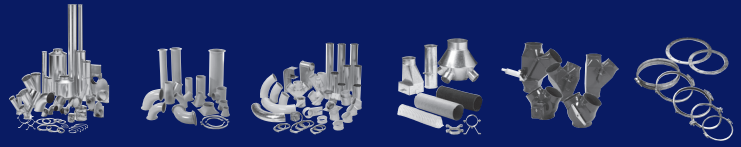

Clip bands, galvanised

Technical catalogue: Duct systems
 Section: 09
 Page: 1/4
 Revised: 01.05.2009

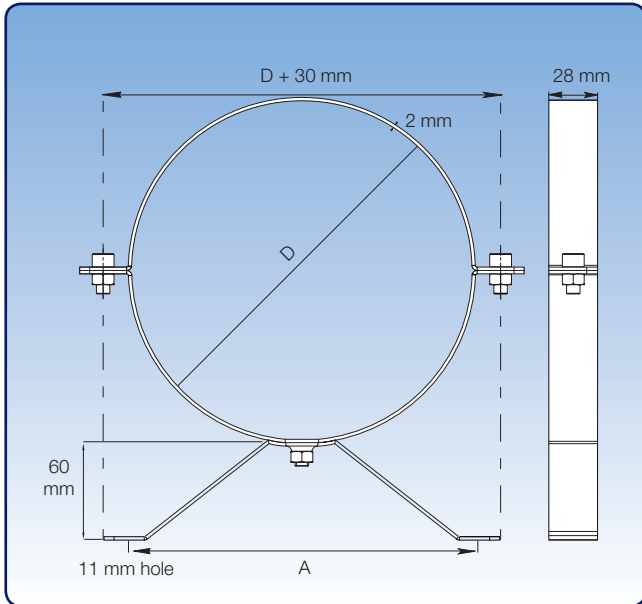

Diameter: $\varnothing 80 - \varnothing 315$ mm.

Supplied for mounting Kongskilde duct systems. 3 different mounting principles: with legs, wall mounted and hanging.

Recommended distance between bands: 1 band to every other assembly.

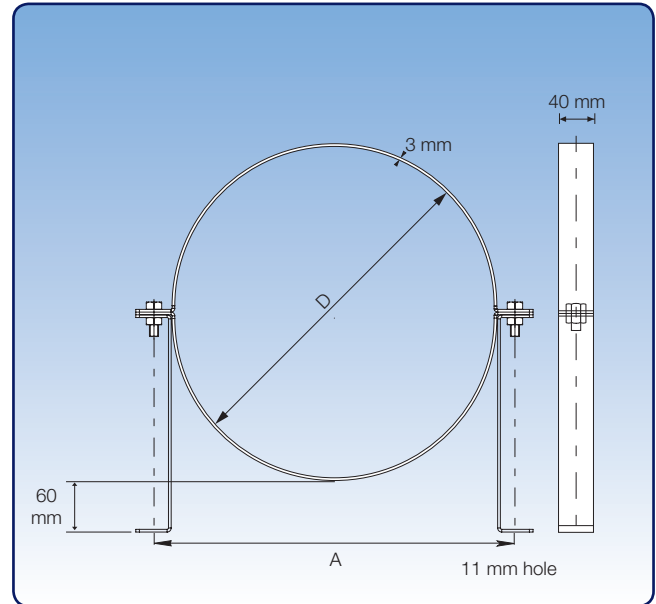

Diameter: $\varnothing 350 - \varnothing 800$ mm.

Supplied for mounting Kongskilde duct systems. 3 different mounting principles: with legs, wall mounted and hanging.

Recommended distance between bands: 1 band to every other assembly.

s = 2 mm			
Item no.	D mm	A mm	Weight kg
9254640290	80	132	0,27
9254641290	100	132	0,29
9254642290	120	132	0,32
9254643290	125	132	0,33
9254644290	140	132	0,35
9254645290	150	132	0,36
9254646290	160	132	0,38
9254647290	180	210	0,43
9254648290	200	210	0,46
9254649290	225	210	0,50
9254650290	250	210	0,53
9254650390	275	210	0,57
9254651290	300	210	0,60
9254652290	315	210	0,62

s = 3 mm			
Item no.	D mm	A mm	Weight kg
9254653290	350	240	1,66
9254683290	375	426	1,71
9254654290	400	451	1,83
9254684290	425	476	1,91
9254655290	450	501	2,01
9254685290	475	526	2,08
9254656290	500	551	2,27
9254657290	550	601	2,33
9254658290	600	651	2,42
9254658330	630	681	2,51
9254658390	650	701	3,64
9254659290	700	761	3,88
9254659390	750	811	4,09
9254659490	800	861	4,31

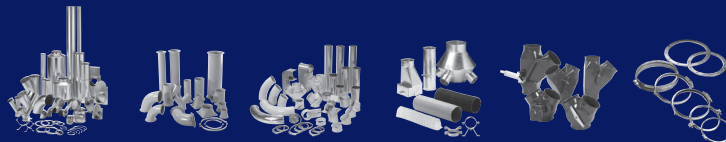

Clip bands, primed, heavy design

Technical catalogue: Duct systems
 Section: 09
 Page: 2/4
 Revised: 01.05.2009

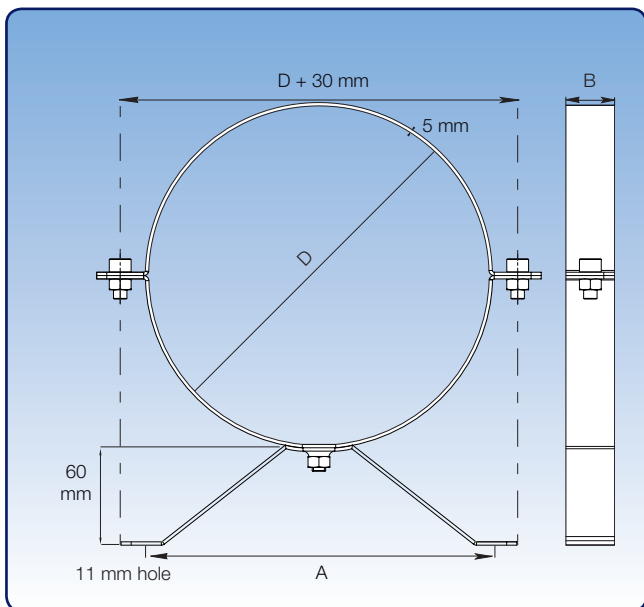

Diameter: $\varnothing 80 - \varnothing 315$ mm.

Supplied for mounting Kongskilde duct systems. Can be used for 3 different mounting principles.

Recommended distance between bands: 1 band to every other assembly.

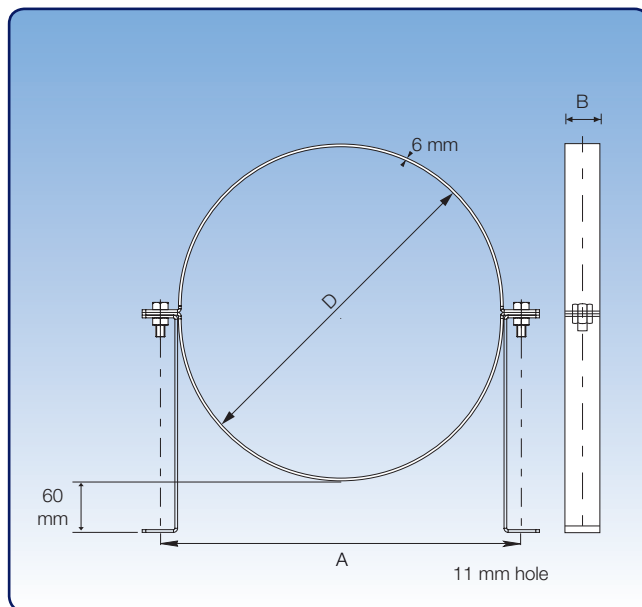

Diameter: $\varnothing 350 - \varnothing 1000$ mm.

Supplied for mounting Kongskilde duct systems. Can be used for 3 different mounting principles.

Recommended distance between bands: 1 band to every other assembly.

s = 5 mm				
Item no.	D mm	B mm	A mm	Weight kg
9254621080	80	25	120	0,58
9254621100	100	25	120	0,64
9254621120	120	25	120	0,70
9254621125	125	25	120	0,72
9254621140	140	25	120	0,77
9254621150	150	25	120	0,79
9254621160	160	25	120	0,82
9254621180	180	25	120	0,94
9254621200	200	25	240	1,00
9254621225	225	25	240	1,08
9254621250	250	25	240	1,16
9254621275	275	25	240	1,23
9254621300	300	25	240	1,31
9254621315	315	25	240	1,35

s = 6 mm				
Item no.	D mm	B mm	A mm	Weight kg
9254623280	350	30	401	2,60
9254624280	400	30	451	2,89
9254625280	450	30	501	3,18
9254626280	500	30	551	3,49
9254627280	550	30	601	3,77
9254628280	600	30	651	4,06
9254629280	630	30	681	4,21
9254630280	650	30	701	4,36
9254631280	700	40	761	6,33
9254632280	750	40	811	6,74
9254633280	800	40	861	7,11
9254634280	850	40	911	7,50
9254635280	900	40	961	7,89
9254636280	950	40	1011	8,30
9254637280	1000	40	1061	8,69

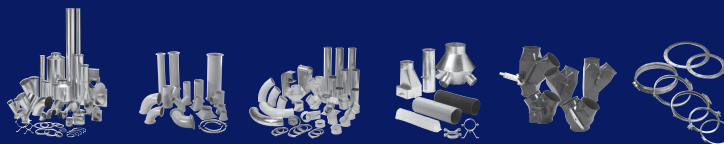

Cutting screens, galvanised

Technical catalogue: Duct systems
 Section: 09
 Page: 3/4
 Revised: 01.05.2009

Diameter: $\varnothing 100 - \varnothing 150$ mm.

Kongskilde's standard range includes cutting screens made of 0.90 mm galvanised sheet metal (s).

Screens supplied with mounting magnets.

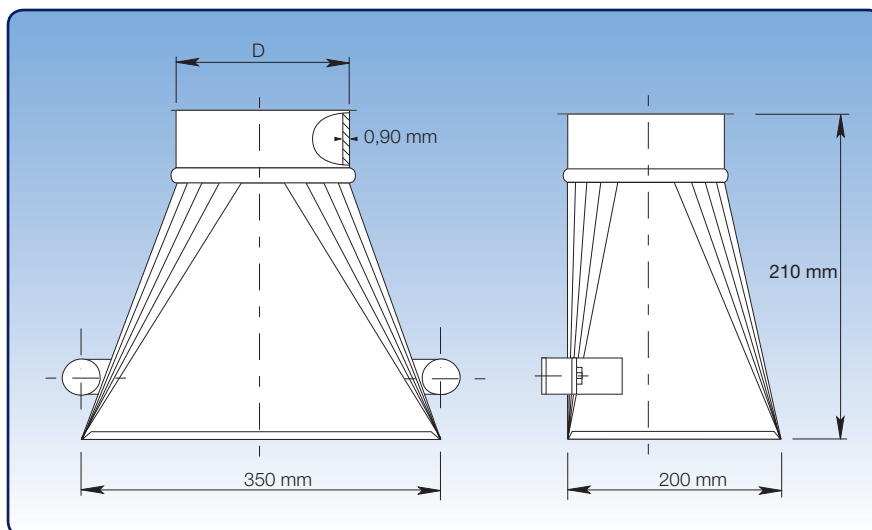

Dimensional specifications are given in the table below.

Item no.	Dimensions		Weight kg
	D mm		
9254671601	100		1,50
9254671602	120		1,75
9254671603	125		1,89
9254671604	140		2,00
9254671605	150		2,25

The item numbers stated are for cutting screens assembled using rapid lock pull rings [f.lyn].

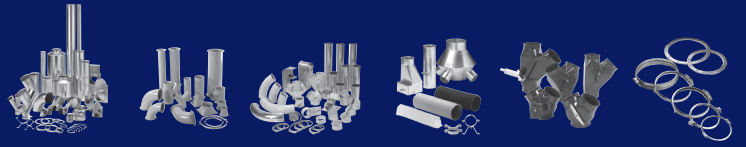

Sweep ups, galvanised

Technical catalogue: Duct systems
 Section: 09
 Page: 4/4
 Revised: 01.05.2009

Diameter: $\varnothing 100 - \varnothing 200$ mm.

Sweep ups for suction of floor areas are made of 0.90 mm galvanised sheet metal.

Sweep ups are fitted with grill and no gate as standard. Can be supplied with both.

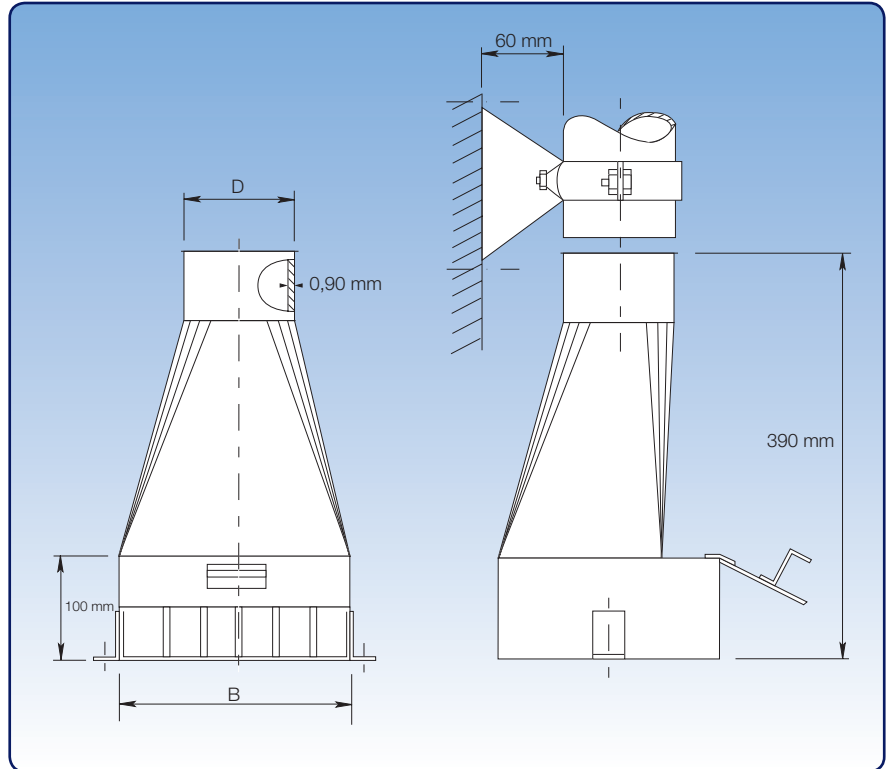

Dimensional specifications are given in the table below.

Item no.	Dimensions		Weight kg
	D mm	B mm	
9254671501	100	220	3,53
9254672501	120	220	3,77
9254673501	125	220	3,77
9254674501	140	220	3,79
9254675501	150	285	3,81
9254676501	160	285	3,88
9254677501	180	285	4,58
9254678501	200	285	4,80

The item numbers stated are for sweep ups assembled using rapid lock pull rings [f.lyn].

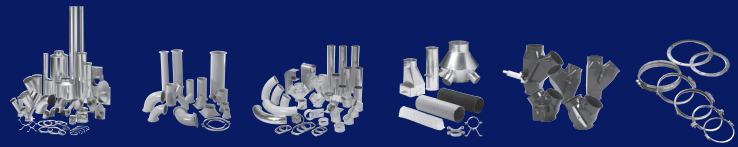

Appendix 1

Technical catalogue: Duct systems
Section: 10
Page: 1/1
Revised: 01.05.2009

Resistance up to overpressure of 9 bar

Ducts and assemblies 2 and 3 mm thickness with welded flanges and flat gaskets up to a diameter of 600 mm.

Ducts up to L = 2000 mm

Galvanised ducts and assemblies 0.9 mm thickness with loose flanges and flat gaskets up to a diameter of 400 mm.

Ducts up to L = 2000 mm

Resistance up to overpressure of 6 bar

Ducts and assemblies 2 and 3 mm thickness with welded flanges and flat gaskets of diameter 600 mm up to 800 mm.

Ducts up to L = 2000 mm

Resistance up to overpressure of 3 bar

Galvanised ducts and assemblies 0.75 mm thickness with 1 pull ring and U-shaped gasket or rapid lock pull rings with U-shaped gasket up to a diameter of 200 mm.

Ducts up to L = 2000 mm

Bends 30° up to 90°

Resistance up to overpressure of 1.5 bar

Galvanised ducts and assemblies 0.9 mm thickness with 1 pull ring and U-shaped gasket or rapid lock pull rings with U-shaped gasket up to a diameter of 400 mm.

Ducts up to L = 2000 mm

To ensure assemblies are tight, screws have to be tightened correctly (torque setting 25 Nm). Using a loose flange assembly, M10 (M12) screws have to be tightened to 40 Nm (60 Nm). The entire duct system must be checked regularly for wear and corrosion to ensure its integrity. Worn components must be replaced.

