

From an operational point of view, we are talking about

- **active biomonitoring**, when "biomonitors" are deliberately introduced into the territory to be examined (they are therefore "allochthonous");
- **passive biomonitoring**, when individuals or populations already present in the area are exploited (they are therefore "native" or "autochthonous").

In the first case it is a matter of defining the standard exposure conditions of the material, then proceeding with the exposure itself.

In the second case, in theory, field work can begin immediately, because it involves collecting material that is already available on site, and which has been exposed to environmental conditions for a definable time based on the life cycle of the target organism .

In both cases, the choice of sampling/exposure sites plays a particularly important role, which should depend primarily on precise sampling strategies aimed at:

- optimize the coverage of the territory in question;
- minimize disturbing factors;
- optimize the cost/information ratio as much as possible.

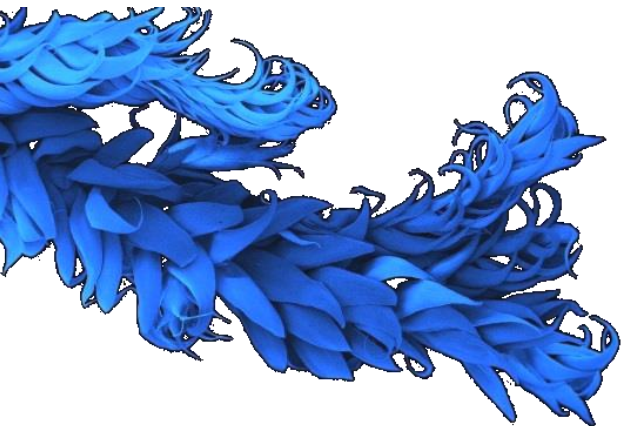

There are two different types of biomonitors:

- **BIOINDICATORS** have high sensitivity towards the stressor, manifesting clear and specific symptoms that are easily quantifiable, undergoing evident variations in physiology, morphology or frequency distribution following the influence of the specific stressor (or group of stressors) present in the environment.
  
- **BIOACCUMULATORS** have high tolerance and accumulation capacity, storing specific substances (e.g. a pollutant, which must have persistence characteristics; alternatively, its stable derivatives must be measured), often without showing symptoms; in this case, the concentration of the substance measured in the body should reflect the environmental one.

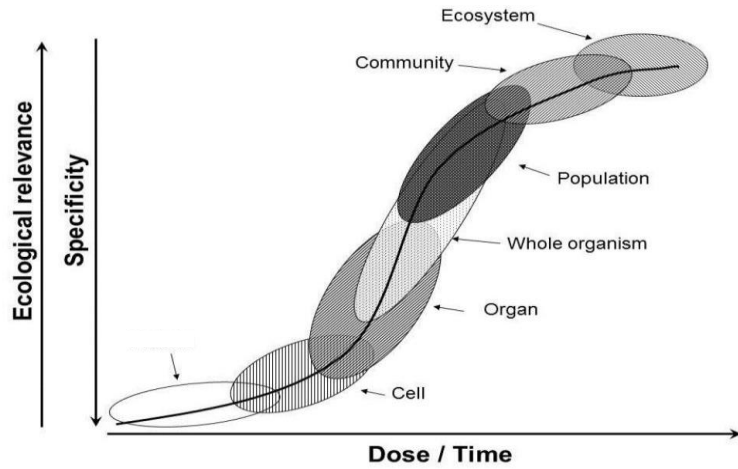

The categories characterizing this complex figure (cell, organ, population etc.) are unified by a basic concept of our discipline, Biology.

Which one???

It is the concept of **SPECIES**.

Surprisingly, also many scientists show a certain difficulty in using explicitly it. The terms «organism» has become progressively more frequent in the literature, and is used as an alternative to species, but also to «individual».

Now, the concept of species, with its name («scientific name», actually the binomial name with its contradictions) is a powerful instrument to get top quality scientific information from the literature (the scientific literature).

Another important point is that biologists and naturalists should be the first to apply, use and defend the concept of species, because we are the «specialists» who can decide what is a good species, and we know how to handle all the rules behind its name.

# Organisms? Better species...



**Spugnòla**

**Erba di Sileno  
Sclopit  
Grisol  
Schioppettini**



...



**Lombrico**

# Organisms? Better species...



**Spugnòla**

***Morchella esculenta* (L.) Pers.**

**Erba di Sileno**

**Sclopit**

**Grisol**

**Schioppettini**

***Silene nutans* L.**



**Lombrico**

***Lumbricus terrestris* L.**

**What can you find in the web by typing the common name and what by typing the scientific name?**

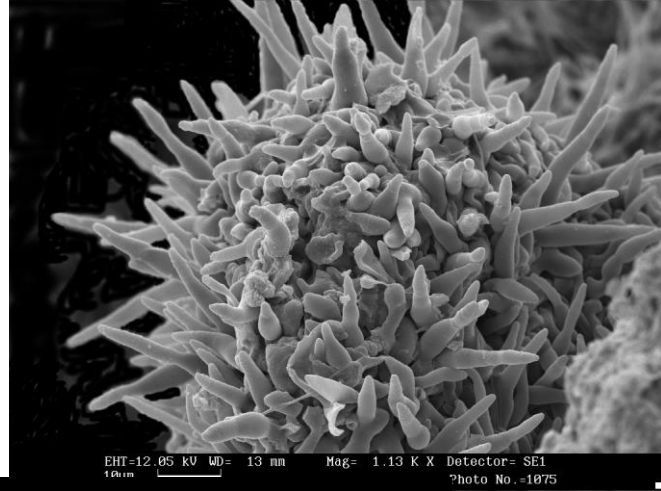



At least seven different SPECIES concepts apply in Biology

## SETTE CONCETTI DI SPECIE

|     | <b>Concetto</b>   | <b>Criterio per la definizione di specie</b> | <b>Riferimento bibliografico</b> |
|-----|-------------------|--|----------------------------------|
| A { | Biologico         | Isolamento riproduttivo                      | Mayr 1963                        |
|     | Riconoscibilità   | Uniformità del sistema riproduttivo          | Paterson 1985                    |
| B { | Evolutivo         | Storia evolutiva comune                      | Wiley 1978                       |
|     | Autapomorfia      | Monofilia                                    | Donoghue 1985; Mishler 1985      |
|     | Genealogico       | Progenitore unico                            | Baum e Shaw 1995                 |
| C { | Fenetico          | Diversificazione morfologica tra le specie   | Sokal e Crovello 1970            |
|     | Diagnosticabilità | Unicità della combinazione dei caratteri     | Nixon e Wheeler 1990             |

**A = Biological/reproductive concept    C = Morphological concept**

**B = Evolutionary concept**

This **BIOLOGICAL** concept of species emphasizes the importance of populations of individuals interconnected by genetic exchanges that occur following sexual reproduction, and which give rise to unlimitedly fertile offspring.

The guiding criterion is therefore the **REPRODUCTIVE ISOLATION** of the species compared to other species.

## Sexual reproduction:

**FUSION OF GAMETES** (reproductive cells: e.g. egg cell + sperm)



## Vegetative propagation:

From the name it is clear that it is particularly frequent among plant organisms.

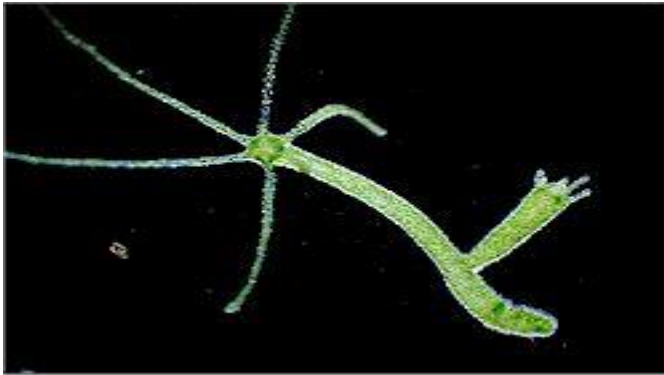

- ◆ budding (e.g. in Hydra, but also in yeast cells);
- ◆ division or fragmentation of the individual mother;
- ◆ production of vegetative propagules;
- ◆ production of structures such as stolons, bulbils, rhizomes, etc.
- ◆ “apomixis””

**Inapplicability for extinct organisms**

## "phylogenetic" or "evolutionary" species concept

"A species is a single lineage of populations formed by progenitor-descendants that is distinct from other lineages and which has its own evolutionary tendencies and a well-defined historical destiny."

Simpson 1951, 1961; Wiley, 1978

This broad definition is intended to define species in terms of evolutionary processes and has the advantage of including both living and extinct organisms, regardless of their reproductive modes.

This definition finds strong support from phylogenetic reconstructions based on genetic analysis

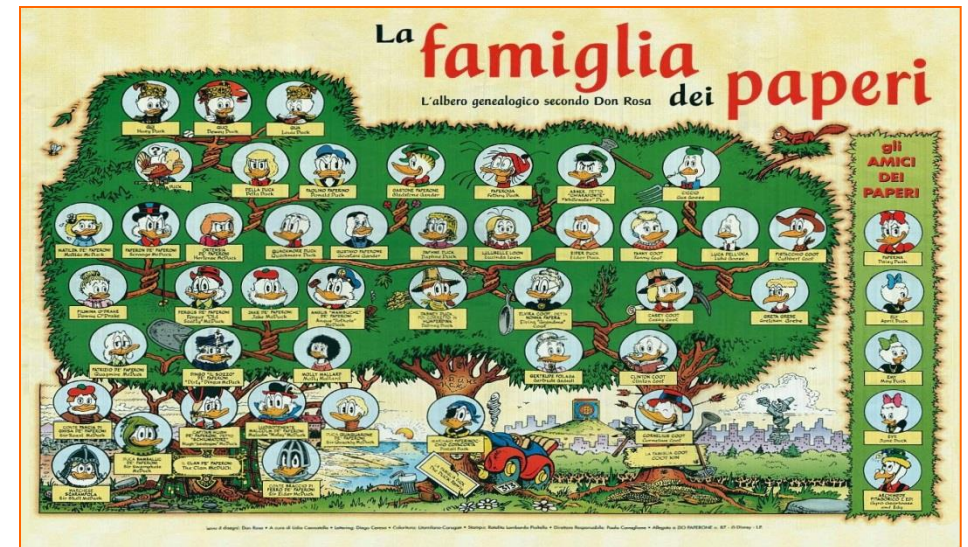

This definition of species has relatively recent roots: the idea of evolution appeared towards the second half of the 17th century, and only after the second half of the 19th century was it widely accepted. In previous times, on the contrary, it was believed that species were IMMUTABLE, having been created by God. Linnaeus himself, the most important systematist of the 18th century, and the young DARWIN supported the idea of the FIXITY of species.

The strongest objection concerns the fact that this concept is difficult to use when trying to identify species in nature, because the criteria - "evolutionary trends" and "historical fate" are at best vague and difficult to know.

## **The concept of "morphological" species**

It is the basis of the oldest and most frequently used method for recognizing species; it is the one used daily by all of us.

*"The smallest set of natural populations permanently separated from others by a distinct discontinuity of character."*

Du Rietz 1930; Cain 1954; Mayr 1963; Shaw 1964

Problematic aspects of this species definition:

1) The comparative criteria underlying this species definition may not reflect the actual phylogenetic relationships between organisms (A and B are similar in those characters, but may NOT even be related [lookalike experience]).

2) The application of this definition leads, for example, to underestimating the frequency of the so-called CRYPTICAL species ("hidden" species), so defined because they are morphologically almost indistinguishable, often coexist in the same territory, but are genetically isolated from each other due to, for example, of a different reproductive biology.

# Individual

## Treccani:

The term individual (from the Latin *individuus*, "undivided, indivisible", composed of *in-* and *dividuus*, "divided", which corresponds etymologically to the Greek *ἄτομος*, composed of *ἀ-* privative and stem of *τέμνω*, "to cut") indicates every single entity as distinct from others of the same species.

**In biology**, an individual means any **animal or plant organism**, uni- or multicellular, which cannot be divided without (at the same time) losing its own structural and functional characteristics.

That is, every **animal or plant organism**, uni- or multicellular, which if divided would lose its own structural and functional characteristics.

**Unitary organisms**



**Modular organisms**



**Is it always valid?**



# Individual

Biol Philos (2016) 31:761–773  
DOI 10.1007/s10539-016-9553-z



EDITORIAL

## The many faces of biological individuality

Thomas Pradeu<sup>1</sup>

An accepted unifying concept/definition of biological individual does not exist

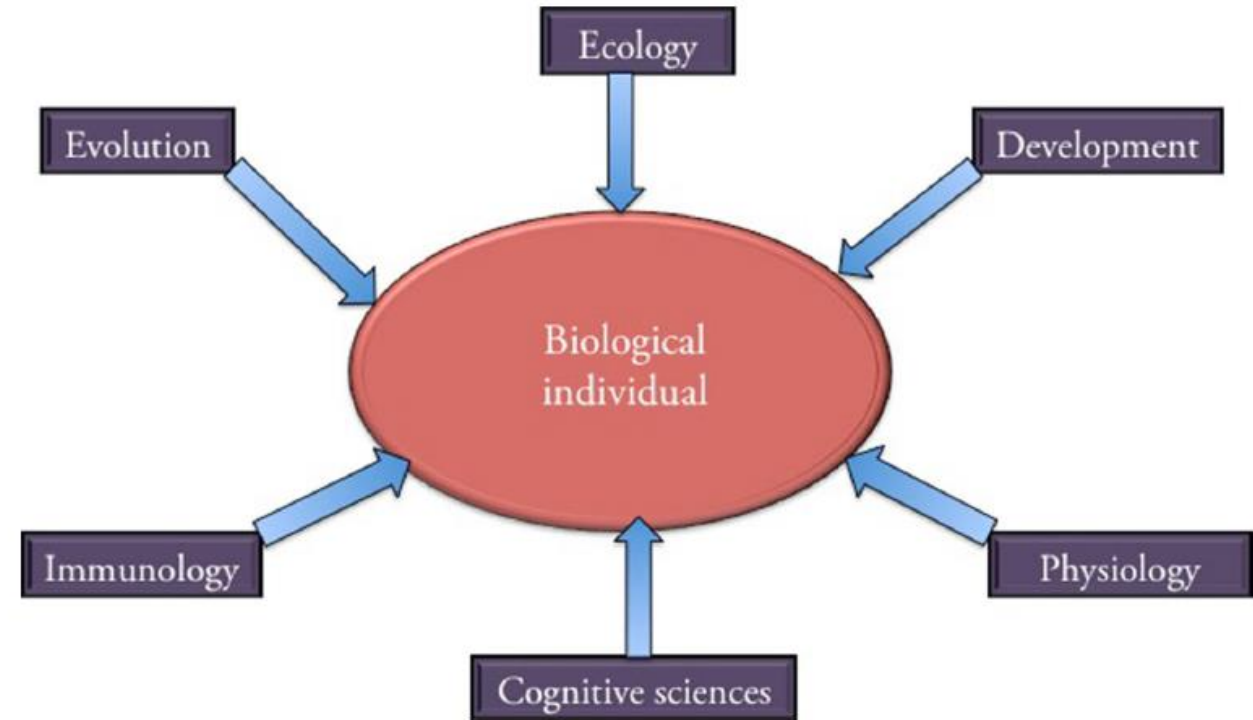

Many of the papers gathered in this special issue are interested in the monism–pluralism debate. Should we adopt several individuality criteria, or should we favour one criterion—and if so which one and with which arguments? Should we ground our concept of individuality in several biological domains or in one given domain—and, here again, if we opt for the monistic choice, on what basis should we do so?

**Table 1** Consensual claims for philosophers and biologists working on biological individuality

| Label                        | Detailed claim  | References   |
|------------------------------|---|--|
| <i>Question-dependence</i>   | The answer to the question ‘what counts as a biological individual?’ will depend to a large extent on the scientific context in which the question is asked   | Sober (1991), Hull (1992), Wilson (1999), Wilson (2005), Dupré (2012), Godfrey-Smith (2013)                    |
| <i>Anti-anthropocentrism</i> | A scientifically fruitful approach to biological individuality should not be based on human intuition, common sense, or perception. It can be very unhelpful to use human beings (or other vertebrates) as the central model for biological individuals | Hull (1978, 1980, 1988, 1992), Wilson (1999)   |
| <i>Hierarchization</i>       | Biological individuality is nested and hierarchical; it can be realized at several different levels of the living world (for example the level of the cell and that of the organism)  | Weismann (1893), Lewontin (1970), Bernard (1974), Hull (1980), Gould and Lloyd (1999), Gould (2002)            |
| <i>Continuity</i>            | Biological individuality comes in degrees; a biological entity can exemplify biological individuality to lesser and greater degrees   | Child (1915), Conklin (1916), Sober (1991), Santelices (1999), Pepper and Herron (2008), Godfrey-Smith (2009). |
| <i>Transitions</i>           | There have been transitions in individuality; through evolution, new levels of individuality have emerged as a result of the coming together of previously distinct entities  | Buss (1987), Maynard Smith and Szathmáry (1995), Michod (1999), Okasha (2006), Godfrey-Smith (2009)            |

# Population

A group of individuals of the **same species** that occupies a certain area in a certain time interval

- ❖ The individuals of a population are interfertile/interfecund and, therefore, they share a common gene pool;
- ❖ the reference to a defined spatial limit is implicit, e.g. the population of *Arnica montana* L. of the Bivera mountain;
- ❖ It is subject to changes over time, e.g. the Italian population after the second world-war was different than the modern one;

## Species vs Population?

The interactions among individuals and the environment generate new properties typical of group of individuals and, thanks to them, the triggering of control and autoregulation processes occur.

The most important are:

- Abundancy of individuals in a population
- The spatial distribution of individuals
- The demographic structure
- The genetic composition



**Very variable over time**

The group composition changes due to births, deaths and movement of individuals, etc.

## **Population Ecology**

**Measuring these properties over time in nature means taking pictures of the population that will need to be contextualized with the time-corresponding environmental conditions.**

# Community

The community is defined as a group of individuals belonging to different species who occupy a determined area and interact between them directly (e.g. predator – prey) or indirectly (competition for resources).

## Meadow



## Garden



A stable community is an association of populations of species sharing similar ecological requirements in an environment characterized by stable ranges of abiotic factors that **have reached equilibrium spontaneously.**

The stable community is thus our reference as it is the repository of information of the normal sinecology of that association of species.

**Sinecology:** chapter of general ecology, animal or plant, which deals with the relationships that exist between the environment and groups of species and individuals, such as communities

**Disturbances** of the abiotic or biotic factors characterizing the «X» community might result in a change of the community equilibrium, resulting in impairments of populations of species -> decrease in individuals and in the worst case, biodiversity loss.

**Monitoring over time and space the community structure could give us the means to identify ongoing changes caused by unknown disturbances**

**Identifying the cause requires a strong knowledge of the species comprising the community especially in their autoecology and sinecology**

**Autoecology:** Chapter of animal or plant ecology which, in opposition to synecology, investigates the relationships between the environment and a species, a race or other systematic category; or between the environment and single individuals, regardless, as far as possible, of the relationships that are established between the groups investigated and other systematic groups and individuals.

## Back to species!

### Species Ecological Niche:

Ecological niche is a term for the position of a species within an ecosystem, describing both the range of conditions necessary for persistence of the species, and its ecological role in the ecosystem. Ecological niche encloses all of the interactions between a species and the biotic and abiotic environment.

**Hutchinson (1957)** expressed this concept to represent it "mathematically": Niche is an "**n-dimensional hypervolume**", where **the dimensions are environmental conditions and resources, that define the requirements of an individual or a species to practice its way of life, more particularly, for its population to persist.** The "hypervolume" defines the multi-dimensional space of resources (e.g., light, nutrients, structure, etc.) available to (and specifically used by) organisms, and "all species other than those under consideration are regarded as part of the coordinate system".

An organism free of interference from other species could use the full range of conditions (biotic and abiotic) and resources in which it could survive and reproduce which is called its **fundamental niche**.

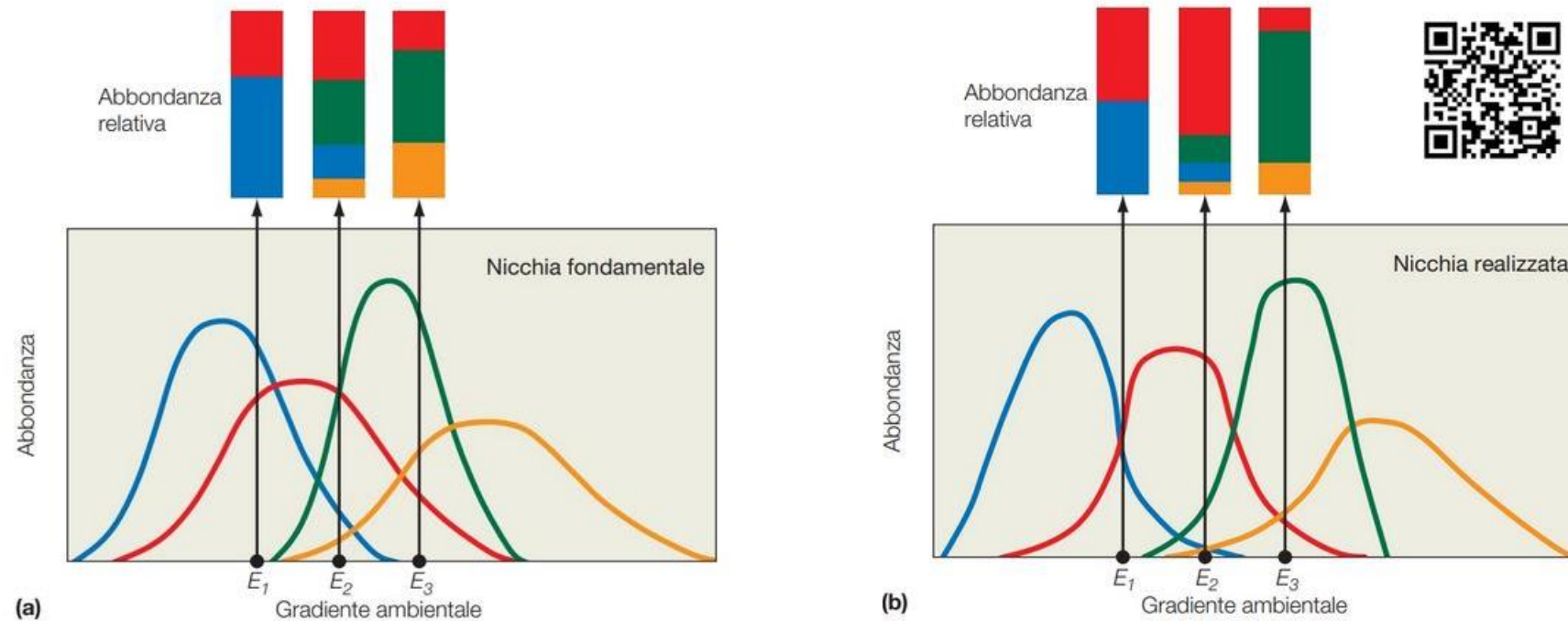

As a result of pressure from, and interactions with, other organisms species are usually forced to occupy a niche that is narrower than this (i.e. inter-specific competition), or larger (i.e. facilitation and mutualism) and to which they are mostly highly **adapted**; this is termed the **realized niche**.



# Species and Ecological Indicator Values (EIV)

Ecological Indicator value is a term that has been used in Plant Ecology for two different indices. The older usage of the term refers to Ellenberg's indicator values from 1974, which are based on a simple ordinal classification of plants according to the position of their realized ecological niche along environmental gradients. Since 1997, the term has also been used to refer to Dufrêne & Legendre's indicator value, which is a quantitative index measuring the statistical alliance of a species to any one of the classes in a classification of sites.

Ellenberg's indicator values were the first model of bioindication proposed and applied to the **flora of Central Europe**, and they have a long tradition in interpretation and understanding of plant communities and their evolution.

The latest edition of Ellenberg's indicator values applies a 9-point scale for each of seven gradients:<sup>1</sup>

R - reaction (soil or water acidity/pH);

N - nitrogen (but really soil fertility or productivity, and not mineral nitrogen; perhaps better «nutrients»)

F - soil humidity or moisture

S - salt (soil salinity)

K - climatic continentality

L - light availability

T - temperature

Indicator values have also been published in 1977 for Switzerland (Landolt's Indices), Great Britain (Hill and coworkers), France and some other national or regional floras.

The use of «ecological indicator values» is widespread, representing a useful instrument for an indirect characterization of the environment on the basis of the information provided by the species present in a specific area, community or habitat.

EV are particularly useful for checking the variation on both local and national scale, if the data source (vegetation data, for list of species, and EV themselves) are «robust».

## **HOW are EV built?**

Individual plant species are assigned so-called ecological indicator values (EIVs) on ordinal scales based on the “optima” or “centres” of their realised ecological niches along given environmental gradients (niche dimensions).

“Realised niche” refers to the occurrence of species in plant communities under the influence of competition (or facilitation) of co-occurring species, as opposed to the “fundamental niche” describing the occurrence and performance in monoculture.

To assess the site conditions of a vegetation plot or a plant community, the EIVs of all species present in that plot or community can be averaged for each niche dimension of interest.

The idea of using the presence of plants to assess site conditions by qualitatively matching the most probable occurrence of plant species with environmental conditions was introduced to vegetation ecology by Cajander (1926) and Iversen (1936).

Subsequently, Ellenberg (1950a, 1950b, 1952) introduced the first explicitly quantitative approach within an agricultural context. Comprehensive EIV systems for the vascular plants of larger territories were then independently proposed by Ramensky et al. (1956) for the European part of the former USSR and Ellenberg (1974) for Central Europe. Ramensky et al. (1956) published indicator values for grazing intensity, soil moisture and a combination of soil fertility and salinity, while Ellenberg (1974; new edition by Ellenberg et al. 1991) covered seven ecological variables: light regime, temperature, continentality, moisture, reaction (pH), nutrient status and soil salinity. The high utility of these indicator values led to an expansion to other regions, with more than 30 EIV systems being published so far.

Some of the more recent EIV systems not only expanded the approach to new regions, but also added other taxonomic groups (e.g. bryophytes, lichens), other niche dimensions (e.g. mowing tolerance, hemeroby, CSR strategy, organic content of the soil, soil texture) or assessed niche width in addition to niche position.

Very recently, new systems with a focus on Europe as a whole have been published: Hájek et al. (2020) published niche position, minimum and maximum for hydrological parameters for a comprehensive set of vascular plants and bryophytes occurring in mires, while Midolo et al. (2023) derived a set of five disturbance indicators for more than 6,000 European vascular plants. Recently, Tichý et al. (2023) presented a harmonized dataset of six of the original Ellenberg indicator values for almost 9,000 European vascular plant taxa.

Indicator values are widely applied in vegetation science and global change studies. They are suitable to indirectly assess environmental conditions and the drivers of observed vegetation differences in time or space (see review by Diekmann 2003).

## In favour of EIVs....

Several factors can explain the success of their application. First, environmental variables may fluctuate strongly in time and space (e.g. Sercu et al. 2017), making one-time measurements scarcely representative of average conditions or critically limiting extremes (Shipley et al. 2017). Thus, the appropriate assessment of environmental variables often requires repeated measurements (not feasible in many projects) or is costly if to be done across numerous plots. Additionally, measurements obtained at different times and with different techniques and equipment may not be directly comparable.

In contrast, the plant species composition of a site is an expression of the species' responses to the prevailing environmental conditions integrated across the study area (e.g. a plot) over longer time periods (several months to several years). Therefore, bioindication using EIVs offers a less time-consuming and cheaper alternative to the direct measurement of local environmental variables.

Finally, most historical vegetation data do not contain measurements of environmental data.

The ability to reconstruct past environmental conditions from historical relevés or floristic occurrence data can thus be very valuable in assessing trends in environmental change and their effects on biodiversity.

## Against EIVs...

The use of EIVs have also been criticised.

- One line of criticism holds that indicator values have been assigned to plant species mainly based on expert judgement, rather than on accurate measurements.
- Secondly, although large regional differences in the niches of species have been demonstrated, EIVs have often been applied outside the region for which they were developed. This could potentially lead to misinterpretations, but also explains why so many authors proposed their own EIVs for their specific area of interest.
- Another line of critique has warned against averaging indicator values and subjecting them to parametric statistics, since they were defined on ordinal scales. However, analysing mean EIVs does not lead to statistical issues, since the arithmetic means of values of any distribution per se follow a normal distribution.

Ewald (2003) demonstrated the robustness of the correlation of weighted mean of EIVs with environmental measurements, even when species lists were incomplete

One time more, being based on species, the correct identification of species is of paramount importance.

However, the more than 30 national and regional EIV systems lack consistency in scaling and coding of the ecological indicators, as well as in plant nomenclature, impeding analyses at the continental scale.

These issues have partly been solved by the recently published **pan-European EIV systems** (Hájek et al. 2020; Midolo et al. 2023; Tichý et al. 2023) but their coverage of indicators and taxa, respectively, is far from complete. Thus, there is still an urgent need for an integrated and comprehensive EIV system for Europe.

Very recently (2023), Dengler et al. published «Ecological Indicator Values for Europe (EIVE) 1.0», a consistent ecological indicator value system for Europe for five of the main plant niche dimensions: soil moisture (M), soil nitrogen (N), soil reaction (R), light (L) and temperature (T).

- They rescaled the indicator values of each dimension to a continuous scale, in which 0 represents the minimum and 10 the maximum value present in Europe.
- Taxon names were harmonised to the Euro+Med Plantbase.
- For each of the five dimensions, European values for niche position and niche width were calculated by combining the values from the individual EIV systems.
- Using T values as an example, we externally validated our European indicator values against the median of bioclimatic conditions for global occurrence data of the taxa.

In total, the Authors derived European indicator values of niche position and niche width for 14,835 taxa.

The newly developed **Ecological Indicator Values for Europe (EIVE) 1.0**, together with all source systems, is available in a flexible, harmonised **open access database**.

For more detail: <https://vcs.pensoft.net/issue/4448/>



## Examples of other datasets:

**Italic 7.0**, the information system of Italian lichens (<https://italic.units.it/index.php>)



The image shows the header of the ITALIC 7.0 website. The header features a navigation menu with the following items: HOME, QUERY, IDENTIFICATION KEYS, GENERAL INFORMATION, and HOW TO CITE. Below the navigation menu is a banner image showing various lichens. The main content area has a title "ITALIC 7.0, THE INFORMATION SYSTEM ON ITALIAN LICHENS" and authors "P.L. Nimis & S. Martellos". The text describes the system's features and availability.

**ITALIC 7.0**

HOME QUERY IDENTIFICATION KEYS GENERAL INFORMATION HOW TO CITE

### ITALIC 7.0, THE INFORMATION SYSTEM ON ITALIAN LICHENS

P.L. Nimis & S. Martellos

ITALIC 7.0, the latest version of the Information System on Italian Lichens, has been published online on June, 28th, 2022. The system makes available information and resources about the lichens known to occur in Italy. It is maintained and updated by the Research Unit of Professor Pier Luigi Nimis, at the University of Trieste (NE Italy), Department of Life Sciences. Most of the data are derived from the Checklist of the Lichens of Italy by Nimis (2016), but nomenclatural and distributional data are being continuously updated online, and complete identification keys for some areas of the country, as well as for genera or groups of genera, are published online for testing.

In addition, species descriptions are available in ITALIC 7.0 for more than 3.200 infrageneric taxa (several of which are not known from Italy but do occur in neighbouring countries, e.g. in the Alps and in the Mediterranean Region). Further, a searchable archive of images curated by P.L. Nimis and F. Schumm, not limited to taxa occurring in Italy, presently includes more than 45.000 images for more than 6.000 taxa. Additionally, a project for georeferencing all samples collected in Italy from thirteen, mainly modern herbaria was started and completed in the first half of 2022. These herbaria are now searchable online, and dot-maps of herbarium samples are visible in the taxon pages of ITALIC 7.0, and are downloadable in Darwin Core format.

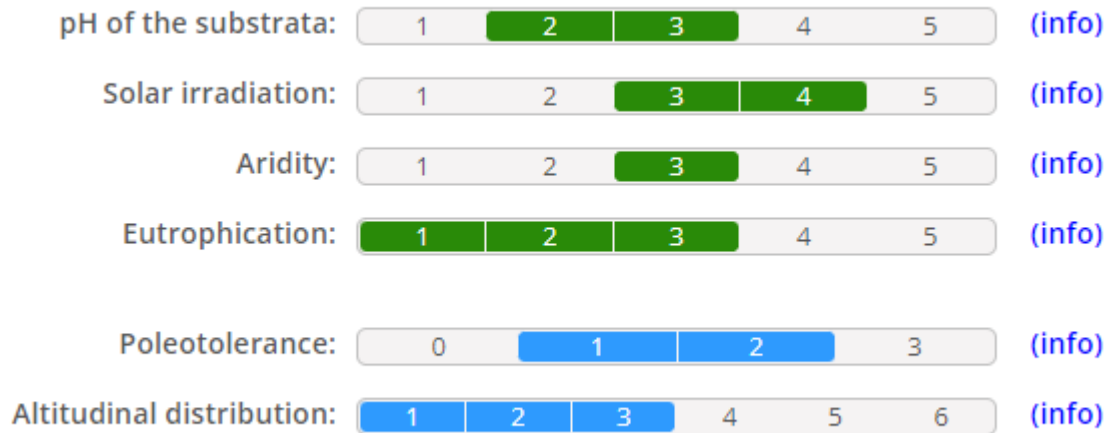

**Solar irradiation (5 states)**

- 1 in very shaded situations, e.g. deep gorges, closed evergreen forests
- 2 in shaded situations, such as on the northern side of boles in close-canopied deciduous forests
- 3 in sites with plenty of diffuse light but scarce direct solar irradiation, such as in rather open-canopied deciduous woodlands
- 4 in sun-exposed sites, but avoiding extreme solar irradiation
- 5 in sites with very high direct solar irradiation, e.g. on the southern side of isolated boles

## BIODIVERSITY OF EPIPHYTIC LICHENS AND AIR QUALITY IN THE PROVINCE OF GORIZIA (NE ITALY)

Giorgio BADIN and Pier Luigi NIMIS

Dipartimento di Biologia, Università di Trieste, Via Giorgieri 10, I-34127 Trieste

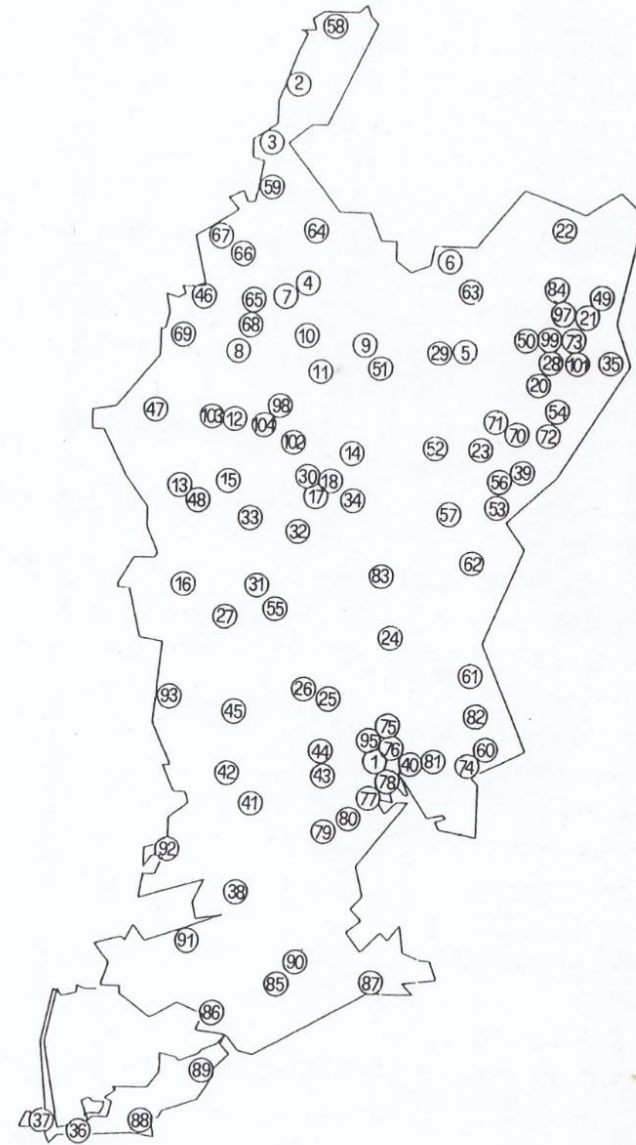
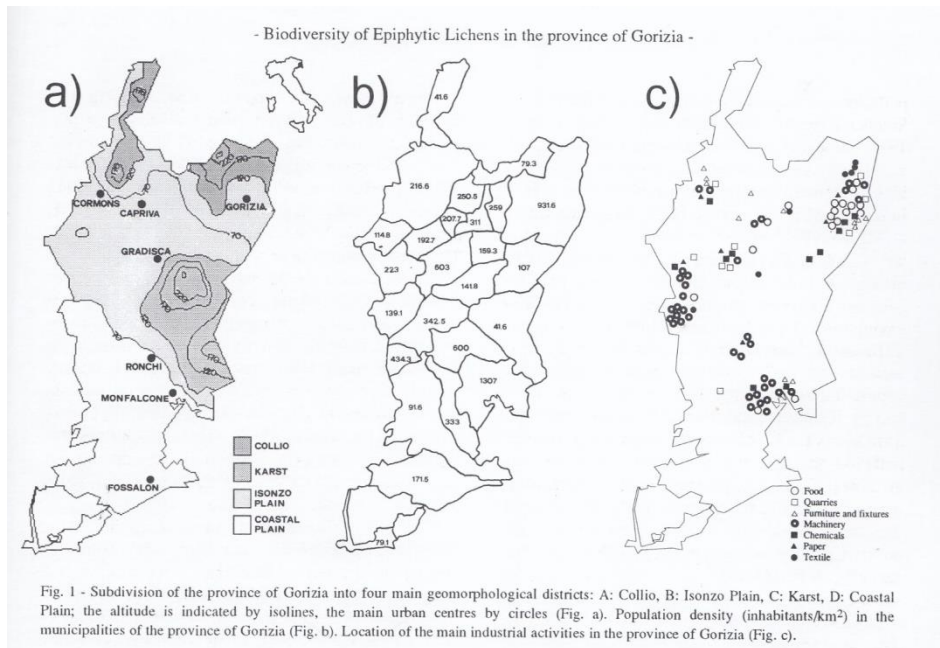

The values of the ecological indices proposed by Wirth (1980), transformed into an ordinal scale as suggested by Nimis *et al.* (1987), were associated to each species. The weighed averages of these values per relevé, using presence-absence data, were used to characterize the ecology of the clusters of relevés, and, in the case of stations, for mapping purposes (see results section).

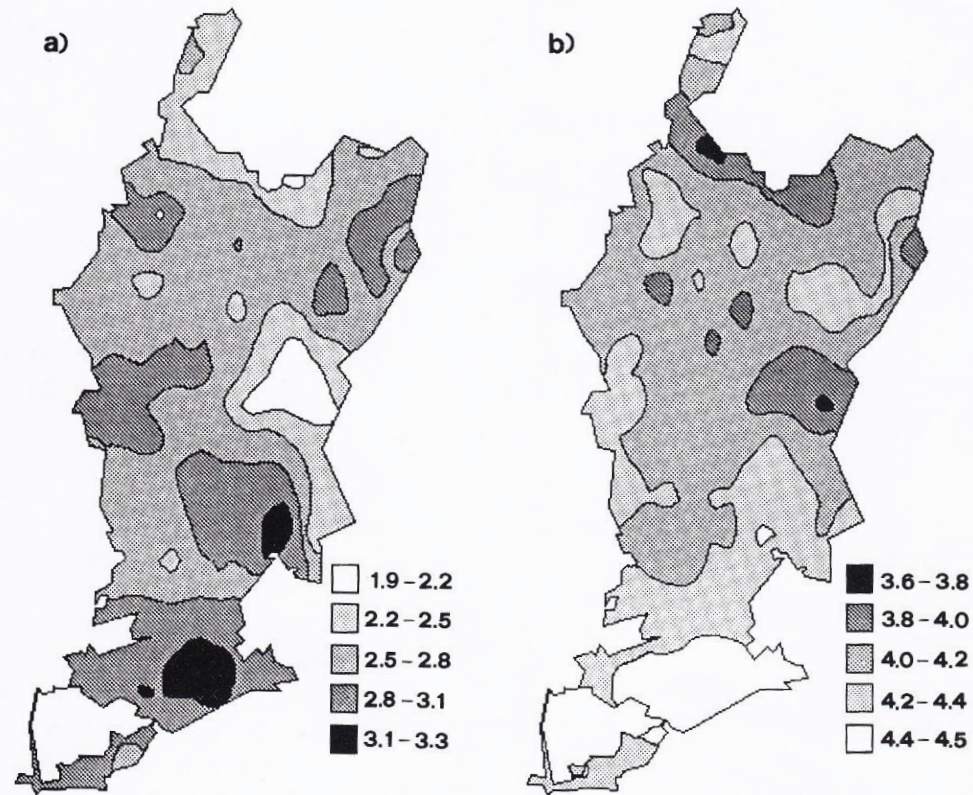

Fig. 11 - Isoporic map showing the distributions of the weighted averages of Wirth's index of nitrophytism (a) and of hygrophytism (b) in the 104 sampling stations.

Not all EIVs have been given on the basis of an expert's assessment...



Nuraghe Nieddu, Codrongianos

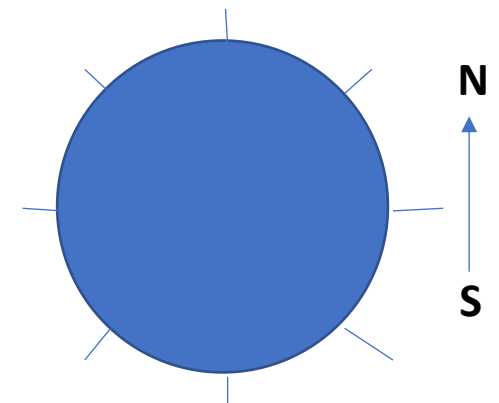
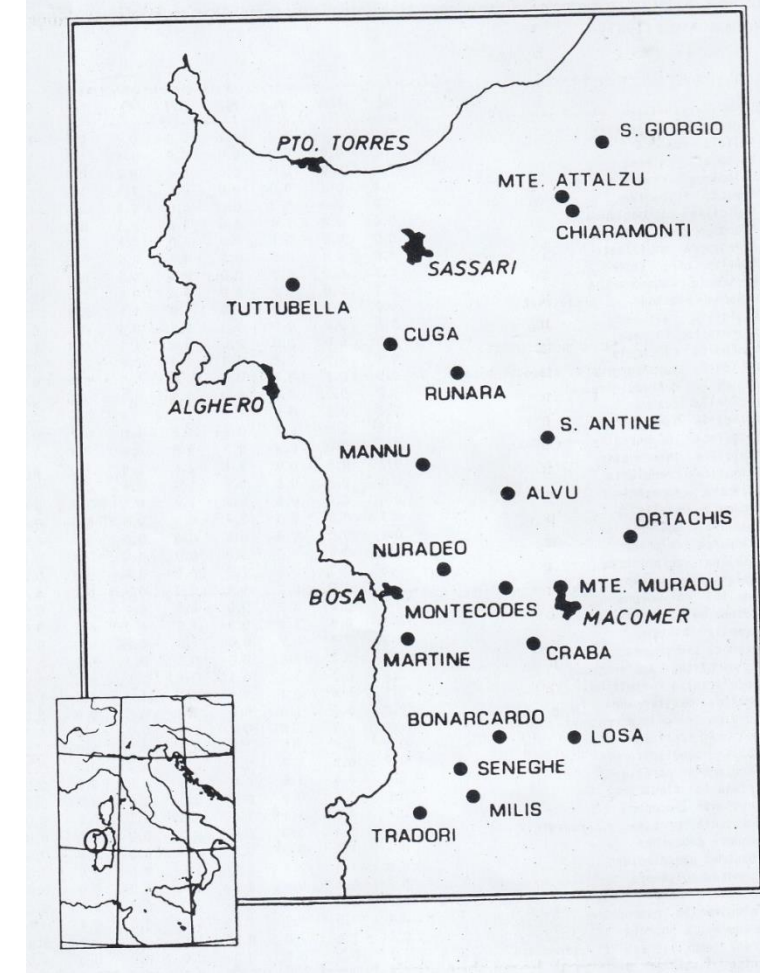
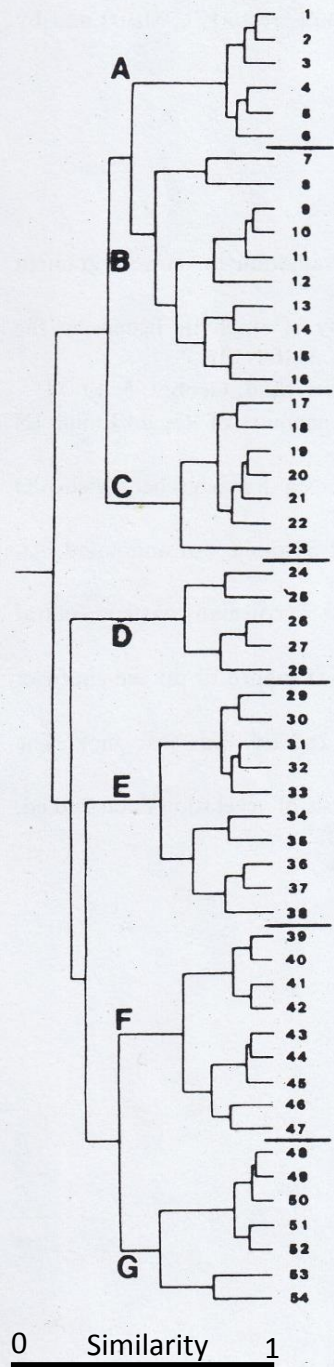

Table 1. Relative frequencies of the species at different exposures. Nomenclature according to NIMIS & POELT (1987).

|  | N   | NW  | W   | NE  | SW  | S   | E   | SE  |
|--|-----|-----|-----|-----|-----|-----|-----|-----|
| 1 Lichinella stipatula                       | 0.0 | 0.0 | 0.0 | 0.2 | 0.0 | 0.7 | 0.2 | 1.4 |
| 2 Peltula euploca                            | 0.0 | 0.0 | 0.0 | 0.0 | 0.0 | 1.9 | 1.5 | 3.7 |
| 3 Caloplaca interna                          | 0.0 | 0.0 | 0.2 | 0.0 | 0.0 | 0.7 | 0.5 | 0.9 |
| 4 Caloplaca irrubescens                      | 0.1 | 0.0 | 0.0 | 0.0 | 0.6 | 1.4 | 1.6 | 2.0 |
| 5 Physcia tribacia                           | 0.0 | 0.0 | 0.0 | 0.0 | 0.0 | 0.4 | 1.1 | 1.0 |
| 6 Aspicilia cupreoglauc                      | 0.0 | 0.2 | 0.4 | 0.0 | 0.0 | 0.3 | 0.8 | 1.1 |
| 7 Acarospora microcarpa                      | 0.0 | 0.0 | 0.4 | 0.0 | 0.0 | 0.1 | 0.2 | 0.2 |
| 8 Acarospora umbilicata                      | 0.0 | 0.0 | 0.5 | 0.0 | 0.2 | 0.6 | 0.0 | 0.0 |
| 9 Buellia cfr. lactea                        | 0.0 | 0.0 | 0.2 | 0.0 | 0.4 | 0.6 | 0.8 | 0.4 |
| 10 Physconia enteroxantha                    | 0.1 | 0.0 | 0.2 | 0.0 | 0.4 | 0.6 | 1.0 | 0.3 |
| 11 Physcia biziana v. phyllidiata            | 0.0 | 0.0 | 0.3 | 0.5 | 1.0 | 1.6 | 2.9 | 0.6 |
| 12 Aspicilia radiosa                         | 0.1 | 0.0 | 0.0 | 0.0 | 0.4 | 0.2 | 0.4 | 0.4 |
| 13 Acarospora fuscata                        | 0.0 | 0.0 | 0.0 | 0.0 | 0.4 | 1.1 | 0.3 | 0.0 |
| 14 Xanthoria calcicola                       | 0.4 | 0.2 | 0.8 | 0.8 | 1.8 | 2.8 | 2.1 | 1.7 |
| 15 Lecidella subincongrua v. elaeochromoides | 0.0 | 0.2 | 0.4 | 0.0 | 0.6 | 0.7 | 0.4 | 0.0 |
| 16 Aspicilia caesiocinerea                   | 0.2 | 0.0 | 0.4 | 0.0 | 0.8 | 0.5 | 0.7 | 0.2 |
| 17 Lecidella scabra                          | 0.2 | 0.2 | 0.0 | 1.1 | 1.2 | 1.6 | 0.5 | 0.2 |
| 18 Aspicilia parasitica                      | 0.2 | 0.0 | 0.2 | 0.5 | 1.2 | 1.0 | 0.7 | 0.2 |
| 19 Caloplaca inconnexa v. nesodes            | 0.1 | 0.0 | 0.2 | 0.8 | 1.0 | 0.6 | 0.5 | 0.2 |
| 20 Aspicilia intermutans                     | 0.3 | 0.6 | 0.9 | 2.1 | 2.6 | 1.9 | 1.0 | 0.6 |
| 21 Caloplaca crenularia                      | 0.3 | 0.2 | 0.4 | 0.9 | 1.4 | 0.6 | 0.5 | 0.4 |
| 22 Lecanora campestris                       | 0.0 | 0.3 | 0.0 | 0.2 | 1.2 | 0.5 | 0.2 | 0.0 |
| 23 Lecanora muralis                          | 0.1 | 0.2 | 0.3 | 0.7 | 0.6 | 0.6 | 0.0 | 0.7 |
| 24 Ramalina requienii                        | 0.2 | 0.0 | 0.0 | 0.5 | 0.0 | 0.0 | 0.4 | 0.0 |
| 25 Caloplaca chlorina                        | 0.4 | 0.0 | 0.2 | 0.8 | 0.0 | 0.6 | 0.6 | 0.2 |
| 26 Ramalina subfarinacea                     | 0.6 | 0.3 | 0.2 | 1.0 | 0.0 | 0.0 | 0.0 | 0.0 |
| 27 Diploicia canescens                       | 1.2 | 0.6 | 0.2 | 1.4 | 0.0 | 0.1 | 0.2 | 0.4 |
| 28 Ramalina polymorpha                       | 0.0 | 0.3 | 0.0 | 0.6 | 0.0 | 0.0 | 0.0 | 0.0 |
| 29 Protoparmelia montagnei                   | 0.3 | 0.3 | 1.2 | 0.0 | 1.0 | 0.0 | 0.2 | 0.0 |
| 30 Parmelia toxodes                          | 0.3 | 0.3 | 0.7 | 0.0 | 1.0 | 0.2 | 0.0 | 0.2 |
| 31 Lecanora sulphurea                        | 0.2 | 0.7 | 1.5 | 0.2 | 0.8 | 0.3 | 0.0 | 0.0 |
| 32 Diploschistes actinostomus                | 0.2 | 0.2 | 1.2 | 0.5 | 0.8 | 0.5 | 0.0 | 0.0 |
| 33 Candelariella vitellina                   | 0.9 | 1.4 | 1.3 | 1.5 | 2.2 | 1.4 | 1.5 | 1.3 |
| 34 Ramalina mediterranea                     | 0.8 | 0.7 | 1.0 | 0.0 | 0.8 | 0.0 | 0.4 | 0.0 |
| 35 Rinodina subglaucescens                   | 1.4 | 0.9 | 1.8 | 0.2 | 0.6 | 0.7 | 0.0 | 0.0 |
| 36 Lecanora schistina                        | 0.5 | 0.4 | 1.8 | 1.0 | 0.0 | 0.0 | 0.0 | 0.0 |
| 37 Buellia subdisciformis                    | 0.9 | 0.2 | 1.2 | 0.5 | 0.0 | 0.0 | 0.0 | 0.0 |
| 38 Ochrolechia parella                       | 1.5 | 1.4 | 1.6 | 2.0 | 0.8 | 0.3 | 0.0 | 0.0 |
| 39 Pertusaria flavicans                      | 0.5 | 1.8 | 0.9 | 0.6 | 0.0 | 0.0 | 0.0 | 0.0 |
| 40 Pertusaria leucosora                      | 0.6 | 2.1 | 1.1 | 1.0 | 0.0 | 0.1 | 0.4 | 0.0 |
| 41 Pertusaria pertusa v. rupestris           | 0.3 | 1.4 | 0.0 | 0.0 | 0.0 | 0.0 | 0.0 | 0.0 |
| 42 Lecanora subcarnea                        | 0.4 | 1.1 | 0.0 | 0.2 | 0.0 | 0.0 | 0.0 | 0.0 |
| 43 Lecanora gangaleoides                     | 0.8 | 1.8 | 2.4 | 0.9 | 1.6 | 0.0 | 0.0 | 0.0 |
| 44 Lecanora polytropa                        | 0.2 | 0.4 | 0.4 | 0.2 | 0.4 | 0.0 | 0.0 | 0.0 |
| 45 Tephromela atra                           | 0.7 | 1.9 | 2.3 | 1.5 | 2.0 | 0.5 | 0.2 | 0.2 |
| 46 Protoparmelia psarophana                  | 0.3 | 1.5 | 1.7 | 0.0 | 0.6 | 0.0 | 0.4 | 0.7 |
| 47 Lecanora sulphurata                       | 0.4 | 1.6 | 1.0 | 0.5 | 1.0 | 0.6 | 0.2 | 0.8 |
| 48 Dirina massiliensis f. sorediata          | 1.5 | 0.3 | 0.0 | 0.0 | 0.0 | 0.0 | 0.0 | 0.0 |
| 49 Dirina massiliensis                       | 2.4 | 0.5 | 0.0 | 0.0 | 0.0 | 0.0 | 0.0 | 0.0 |
| 50 Roccella phycopsis                        | 2.2 | 0.4 | 0.0 | 0.5 | 0.0 | 0.0 | 0.0 | 0.0 |
| 51 Haematomma ochroleucum v. porphyrium      | 0.6 | 0.4 | 0.0 | 0.0 | 0.0 | 0.0 | 0.0 | 0.0 |
| 52 Haematomma ochroleucum                    | 1.0 | 0.9 | 0.0 | 0.3 | 0.0 | 0.0 | 0.0 | 0.2 |
| 53 Lecanora rupicola                         | 0.5 | 0.6 | 0.2 | 0.4 | 0.6 | 0.6 | 0.0 | 0.3 |
| 54 Pertusaria amara                          | 0.9 | 0.4 | 0.8 | 0.6 | 1.0 | 1.0 | 0.0 | 1.4 |



Dendrogram of species, to identify groups of species with similar frequencies at different aspects (N, NE, E, SE etc.)



Ordination of exposures (on a floristic basis)

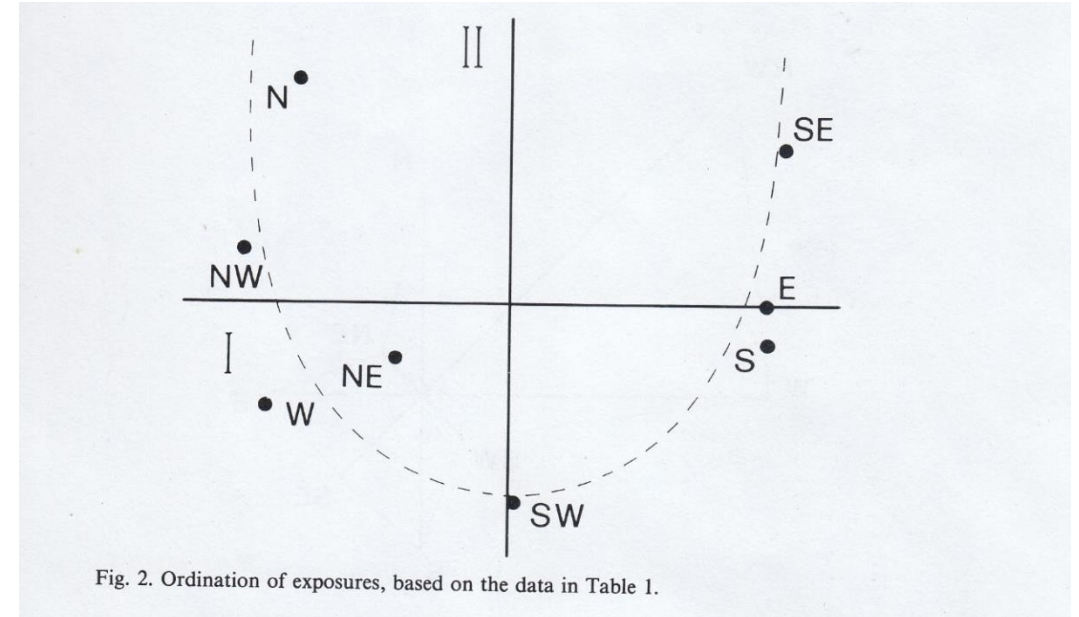

Fig. 2. Ordination of exposures, based on the data in Table 1.

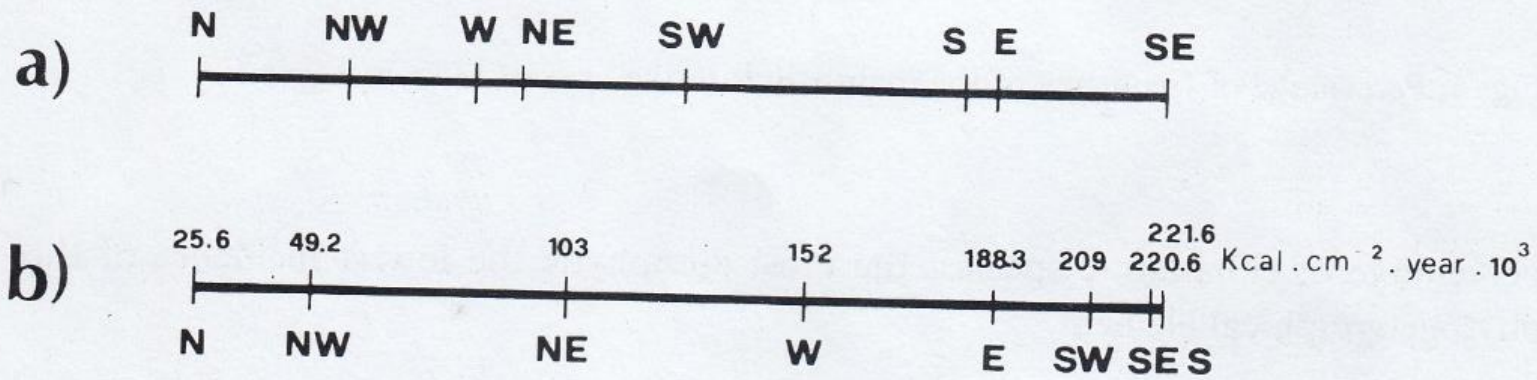

Fig. 3. Arrangement of the exposures according to: a, Angular seriation in the ordination of Fig. 2; b, Potential Solar Irradiation.

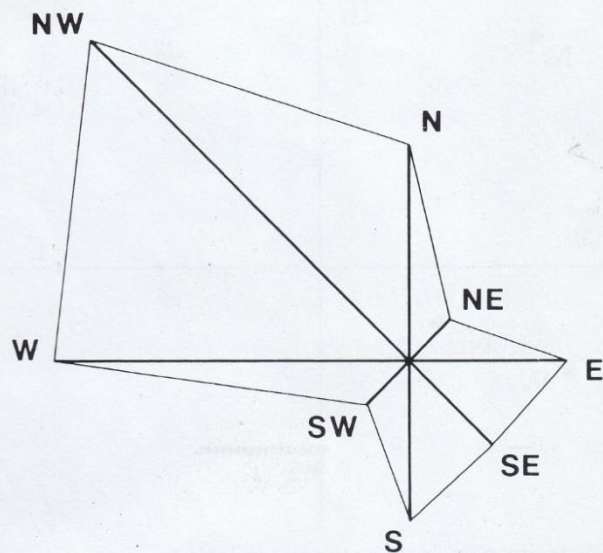

Fig. 4. Percentage of frequency of the main winds in the area of Macomer (see Fig. 1).





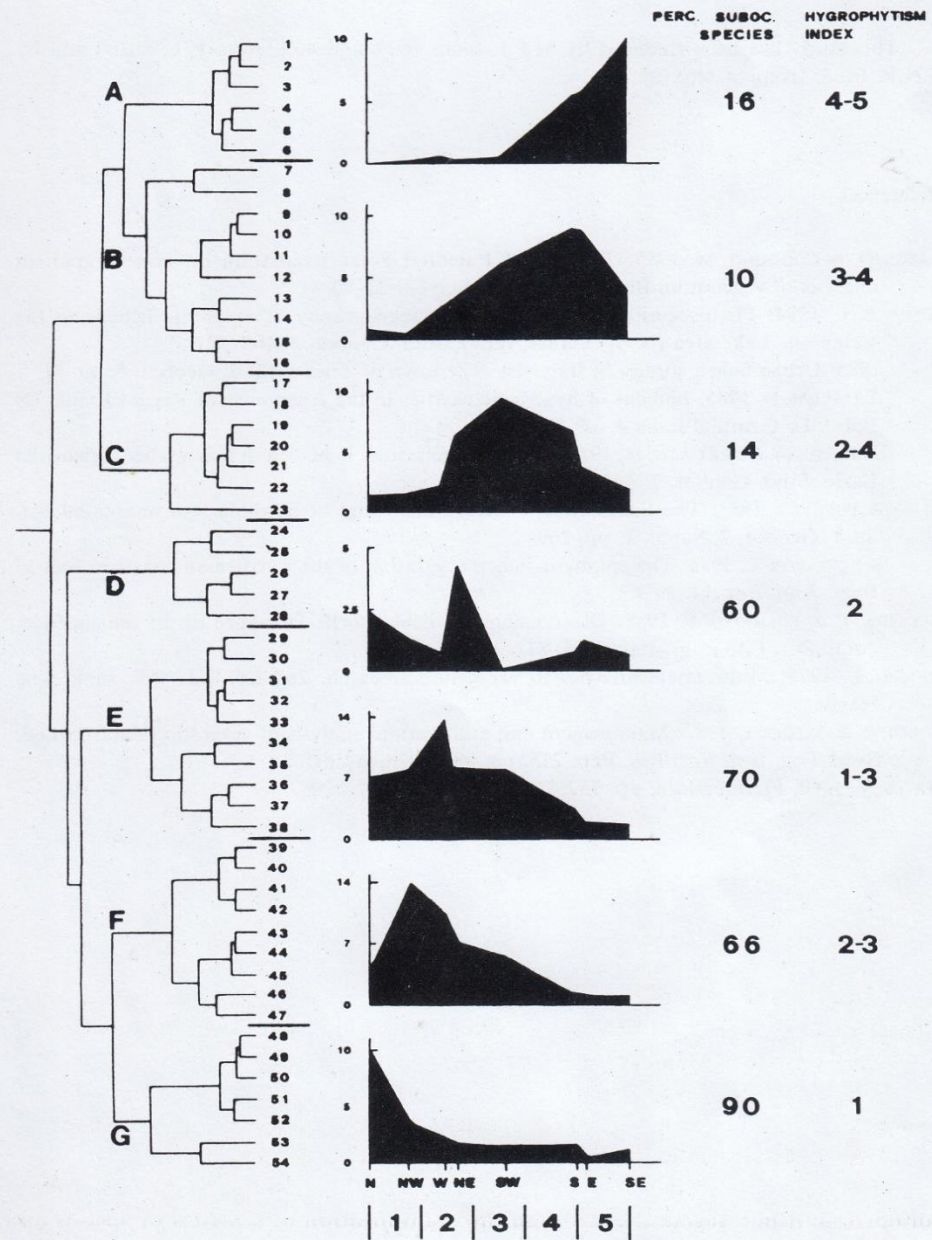

Fig. 5. Dendrogram of the species, based on the data in Table 1, frequency distribution of the species groups along the hygrophytism axis (exposures ordered as in Fig. 3a), percentage of suboceanic species in each group, and indices of hygrophytism.

After such premises, we must discuss why we want to make use of biomonitoring techniques, based on organisms, to characterize or detect or predict possible environmental changes. The discussion is open...