

# Observational Astronomy

## Optical Telescopes



1.02-m Yerkes Telescope



10.4-m Gran Telescopio Canarias

# Learning Objectives

---

- ◆ Telescopes:
  - main types, primary components, and inner workings
  - primary functions
- ◆ Review of Basic Optics:
  - lens and mirror formulae
  - photography versus viewing
  - linear magnification
- ◆ Telescope Optics:
  - focal ratio
  - image size and plate scale
  - field of view at focal plane
  - angular magnification through eyepiece
  - true vs. apparent field of view of eyepiece
  - exit pupil

# Learning Objectives

---

## ◆ Optical Aberrations:

- field curvature
- spherical aberration
- coma
- astigmatism
- distortion
- chromatic aberration

## ◆ Telescope Configurations:

- refractors
- reflectors (Prime, Newtonian, Cassegrain, Coudé or Nasmyth, Schmidt, Schmidt-Cassegrain, Maksutov-Cassegrain)

## ◆ Telescope Mounts:

- equatorial
- altazimuth

## ◆ Telescope Dome and Observatory Site

# Learning Objectives

---

## ◆ Telescopes:

- main types, primary components, and inner workings
- primary functions

## ◆ Review of Basic Optics:

- lens and mirror formulae
- photography versus viewing
- linear magnification

## ◆ Telescope Optics:

- focal ratio
- image size and plate scale
- field of view at focal plane
- angular magnification through eyepiece
- true vs. apparent field of view of eyepiece
- exit pupil

# Telescope Types

---

- ◆ Two main types of telescopes:
  - refractors (objective is a lens)
- ◆ Notice that light (from a single point in the sky) goes in as parallel rays, converges, crosses, and diverges, before going into the eyepiece and emerging as parallel rays but in a smaller bundle.

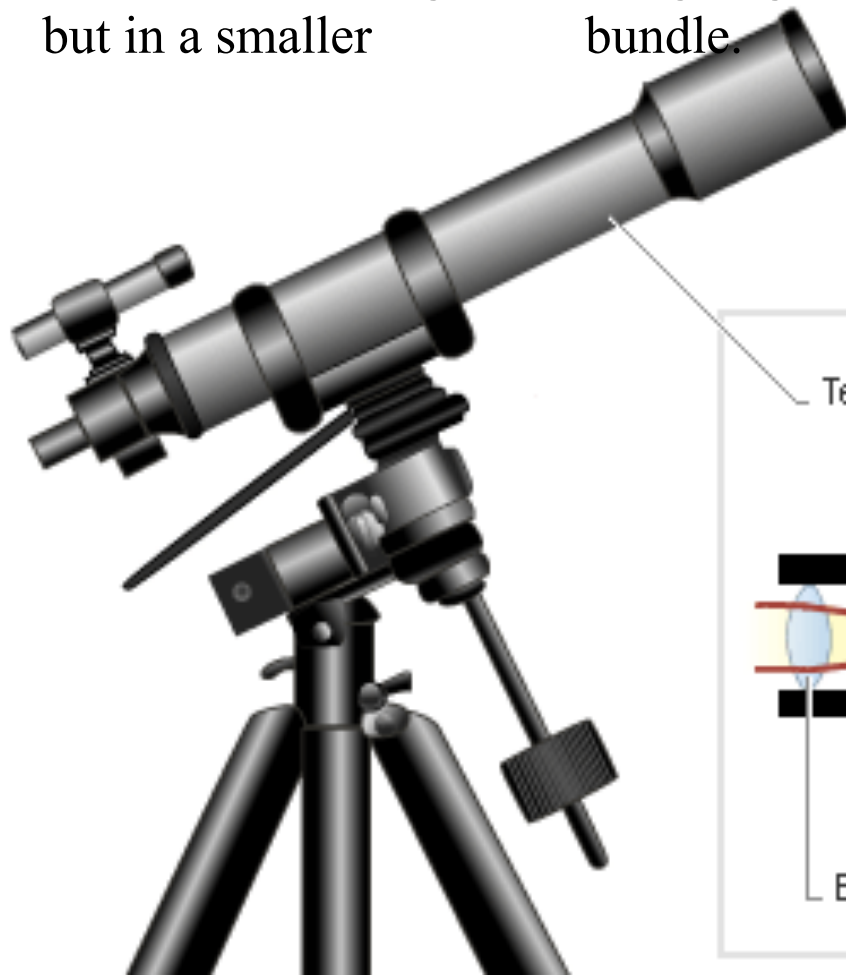

Refracting Telescope  
(Keplerian telescope)

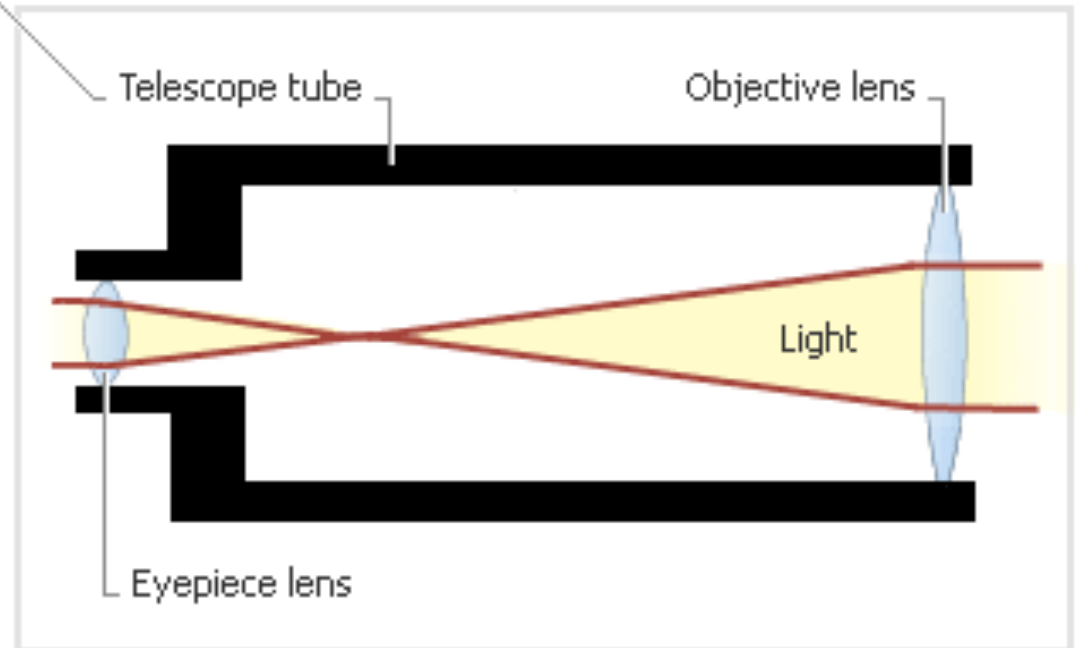

# Telescope Types

---

- ◆ Two main types of telescopes:
  - reflectors (objective is a mirror)
- ◆ Notice that light (from a single point in the sky) goes in as parallel rays, converges, crosses, and diverges, before going into the eyepiece and emerging as parallel rays but in a smaller bundle.



## Newtonian Reflecting Telescope

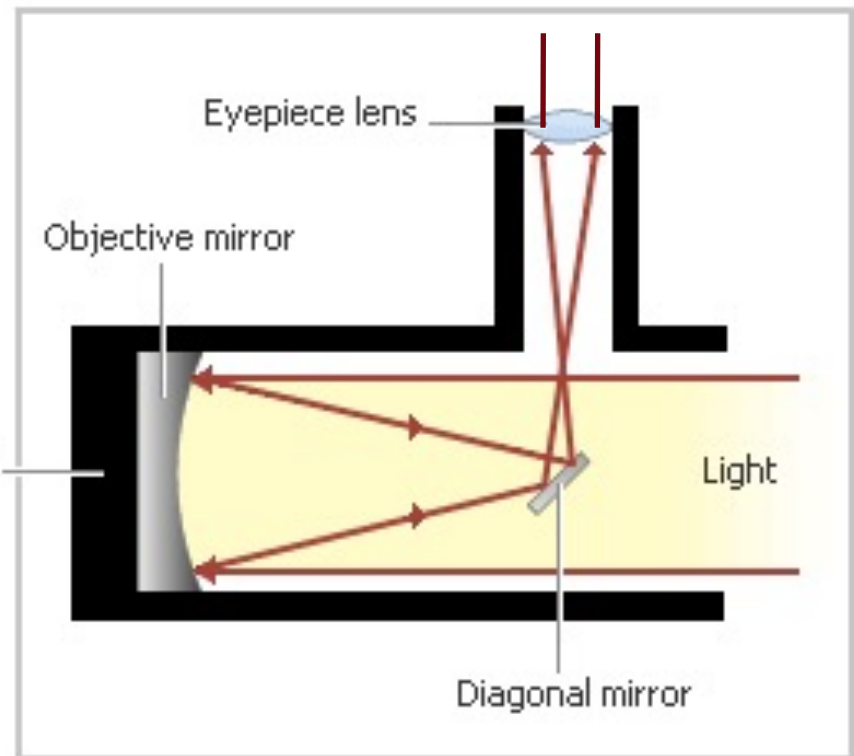

# Telescope Types

---

- ◆ Variant on the main telescope types:
  - Schmidt (objective is a mirror, but employs a correcting lens)
- ◆ Notice that light (from a single point in the sky) goes in as parallel rays, converges, crosses, and diverges, before going into the eyepiece and emerging as parallel rays but in a smaller bundle.

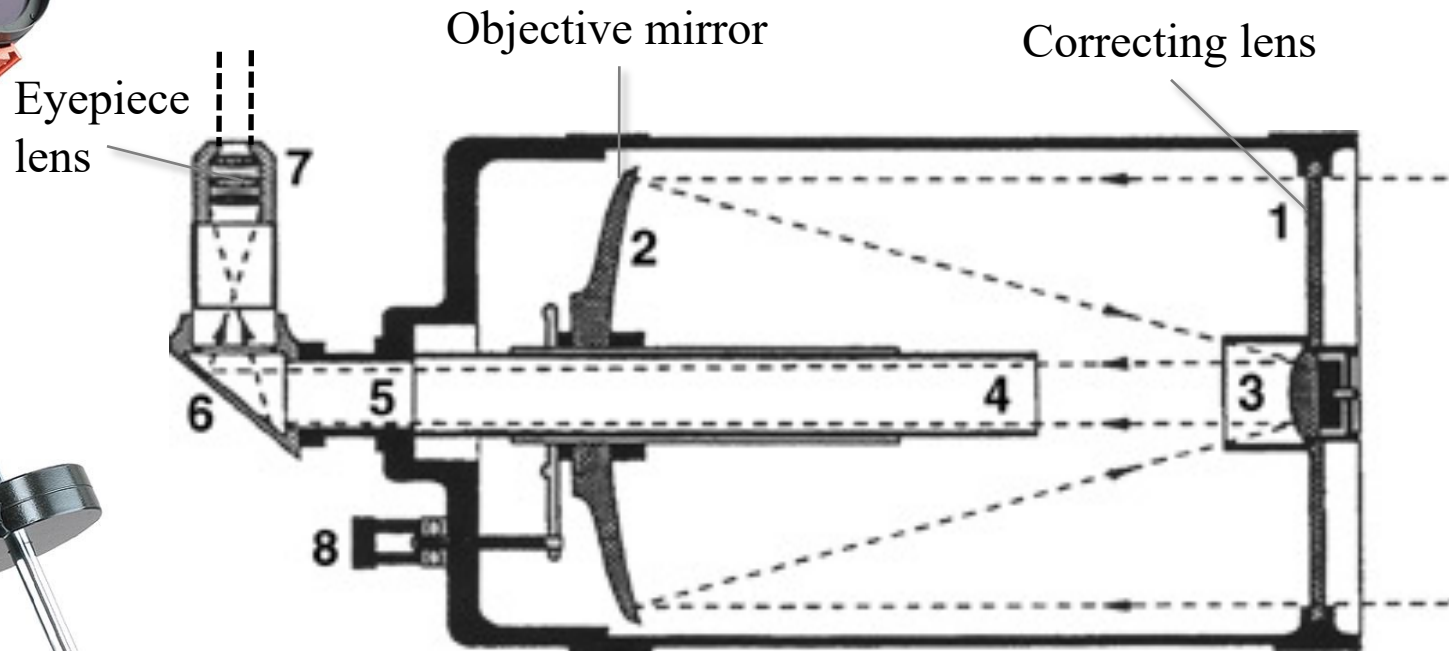

# Light Rays and Wavefronts

- ◆ Light rays indicate the direction in which light travels. Light wavefronts are perpendicular to light rays.

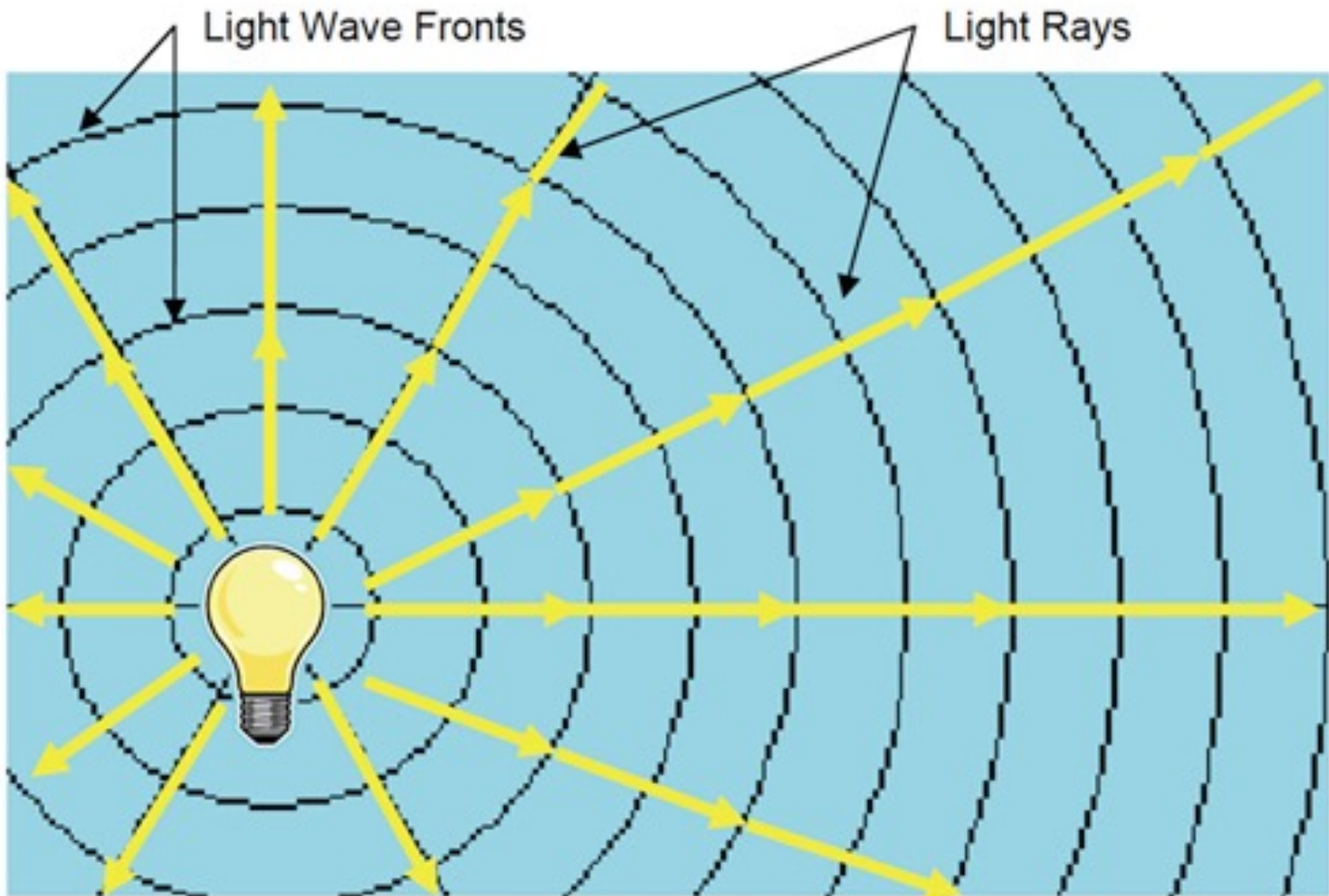



# Light Rays and Wavefronts

---

- ◆ Light rays indicate the direction in which light travels. Light wavefronts are perpendicular to light rays.
- ◆ Close to the light-emitting source, light rays diverge and wavefronts are curved.
- ◆ Far away from the light-emitting source, light rays become increasingly parallel and wavefronts planar.

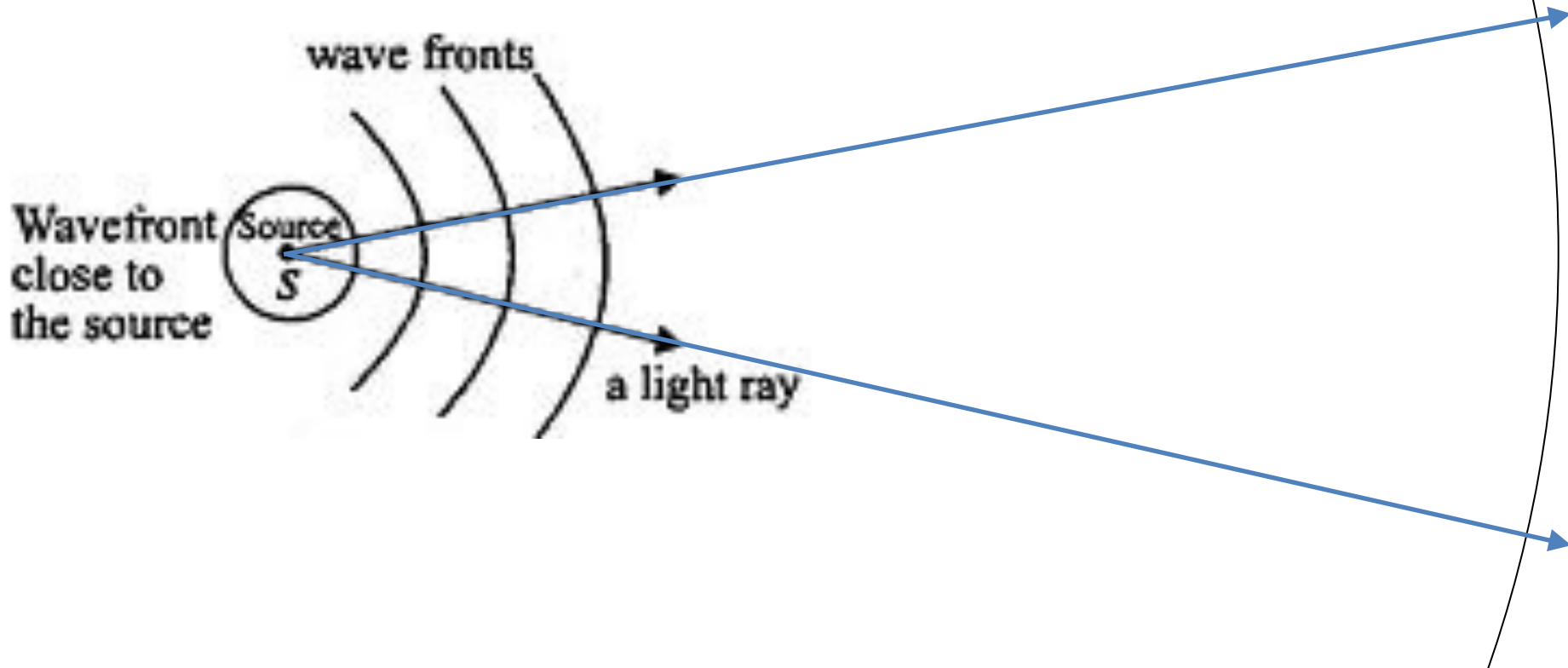

# Light Rays and Wavefronts

---

- ◆ Light rays indicate the direction in which light travels. Light wavefronts are perpendicular to light rays.
- ◆ Close to the light-emitting source, light rays diverge and wavefronts are curved.
- ◆ Far away from the light-emitting source, light rays become increasingly parallel and wavefronts planar.

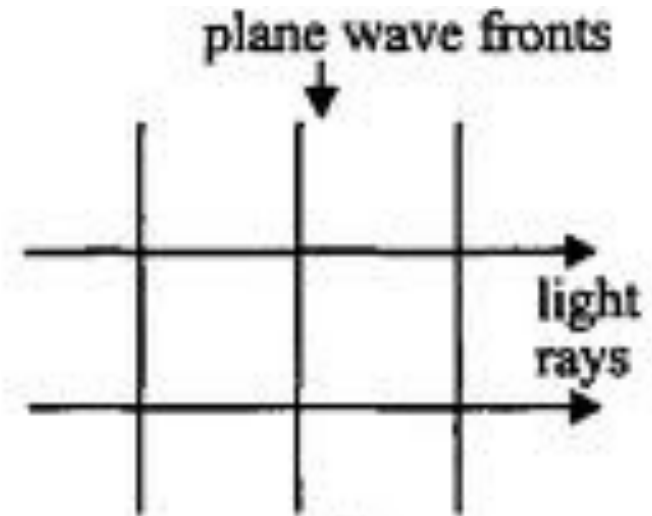
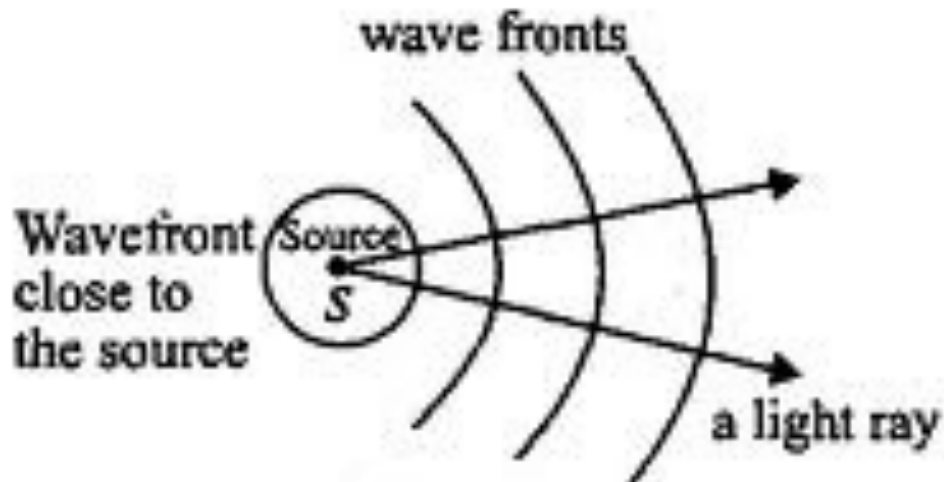

# Parallel Light Rays

- ◆ Astronomical objects are very far, far away. Light rays from (a single point on) astronomical objects appear to be parallel, or equivalently light wavefronts from (a single point on) astronomical objects appear to be planar.

1. Light wavefront from a source is in shape of a **spherical surface**

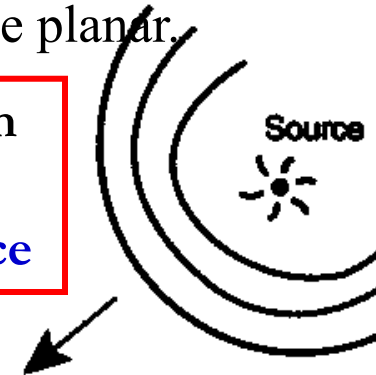

3. A small fraction of the wavefront will be intercepted by the telescope aperture.

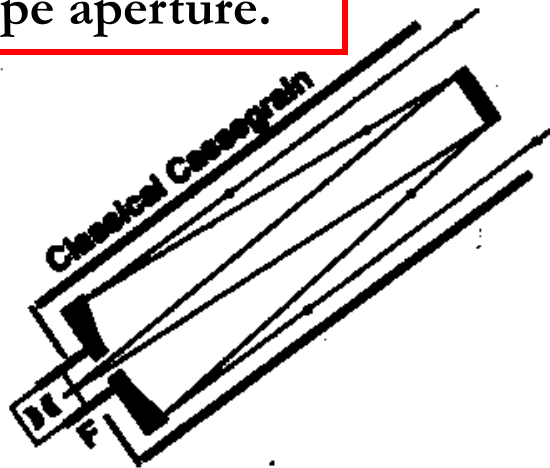

2. After travelling a long distance, incoming light wavefront from a source will be **plane parallel**.

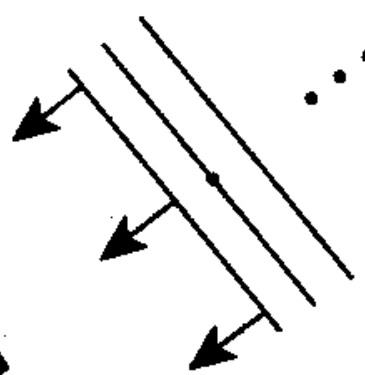

# Parallel Light Rays

- ◆ Astronomical objects are very far, far away. Light rays from (a single point on) astronomical objects appear to be parallel, or equivalently light wavefronts from (a single point on) astronomical objects appear to be planar.

1. Light wavefront from a source is in shape of a **spherical surface**

3. A small fraction of the wavefront will be intercepted by the telescope aperture.

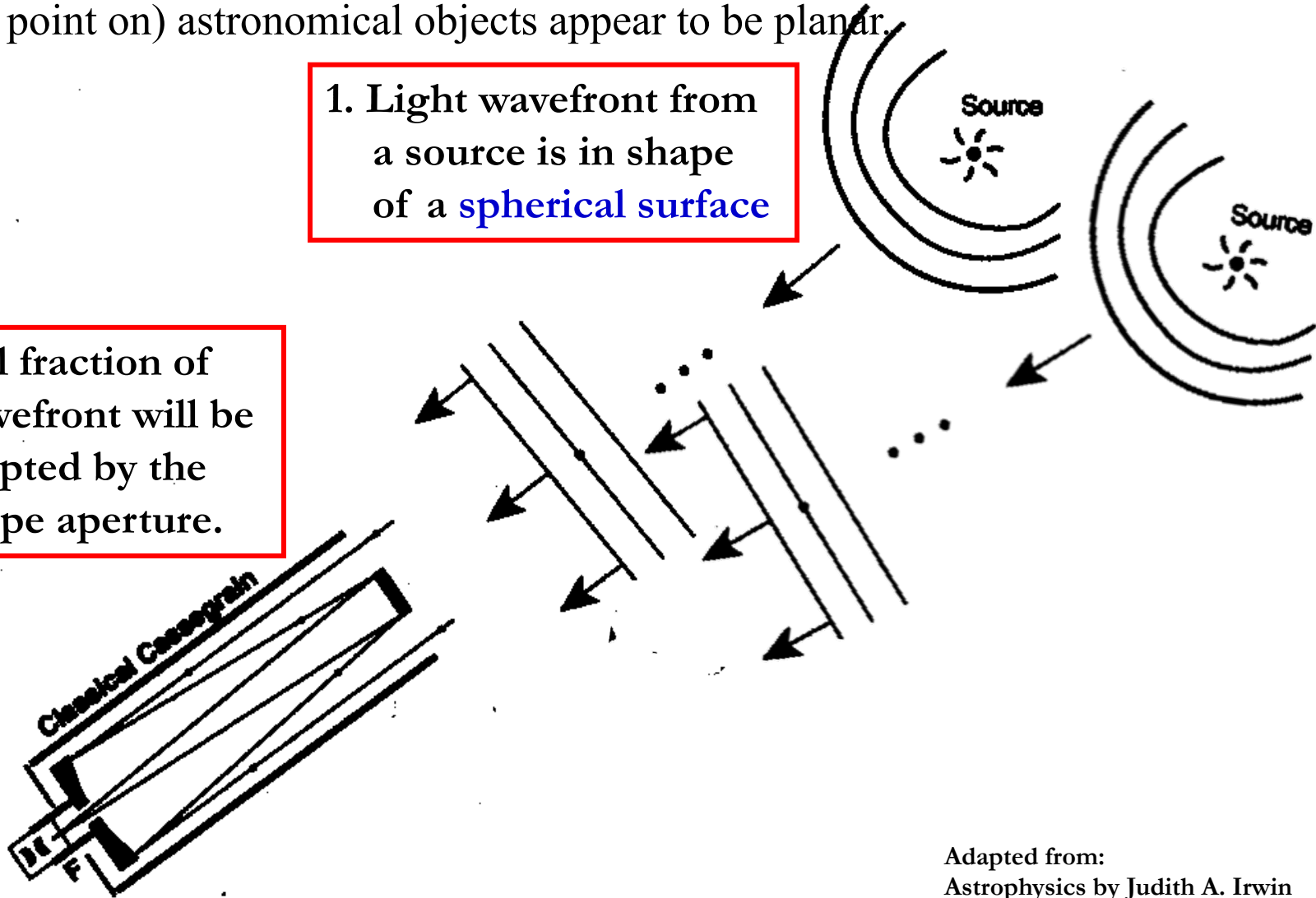

# Human Eye

---

- ◆ Diameter of the pupil differs among people, and is larger in dim than in bright light. We will henceforth assume a typical diameter for the pupil during astronomical observations of  $\sim 7$  mm.
- ◆ The size of the pupil determines the amount of light that the eye collects.

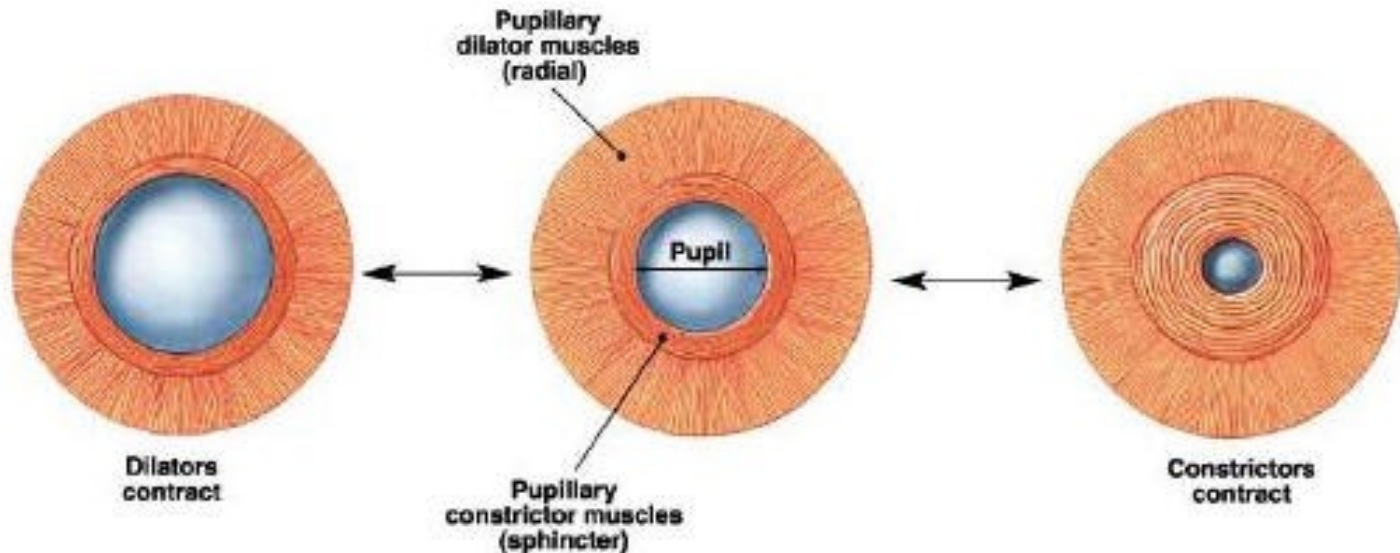
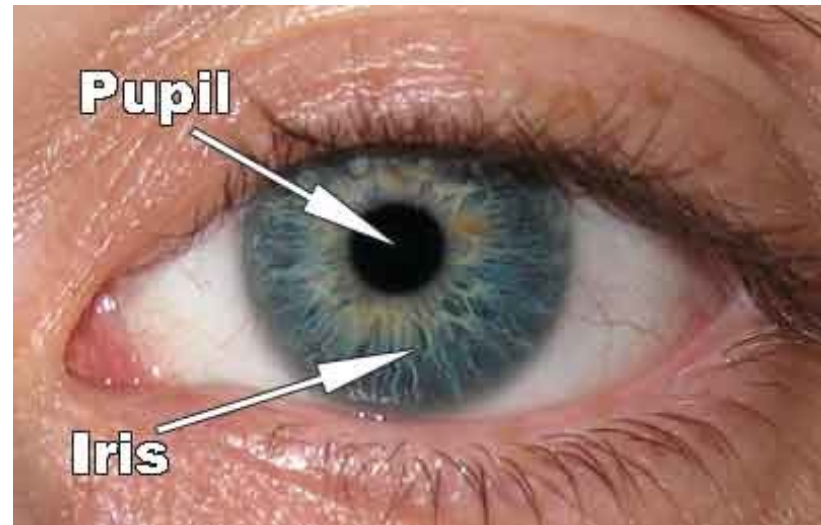

# Human Eye

---

- ◆ Eye brings incident diverging or parallel rays to a focus at the retina.
- ◆ A telescope has to present light in a manner that the eye can collect and focus.

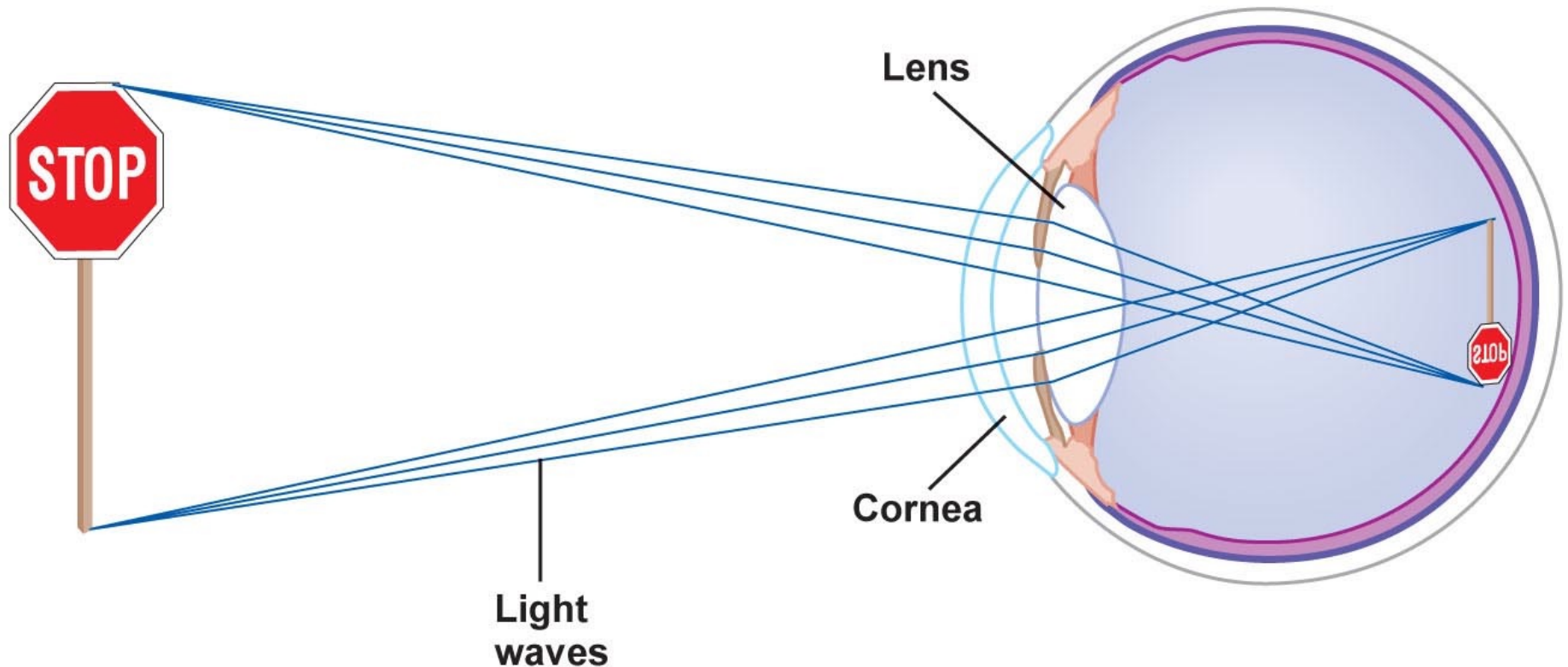

# Human Eye

---

- ◆ Lens in eye is shaped to view objects at different distances. Eye muscles most relaxed when viewing distant objects.

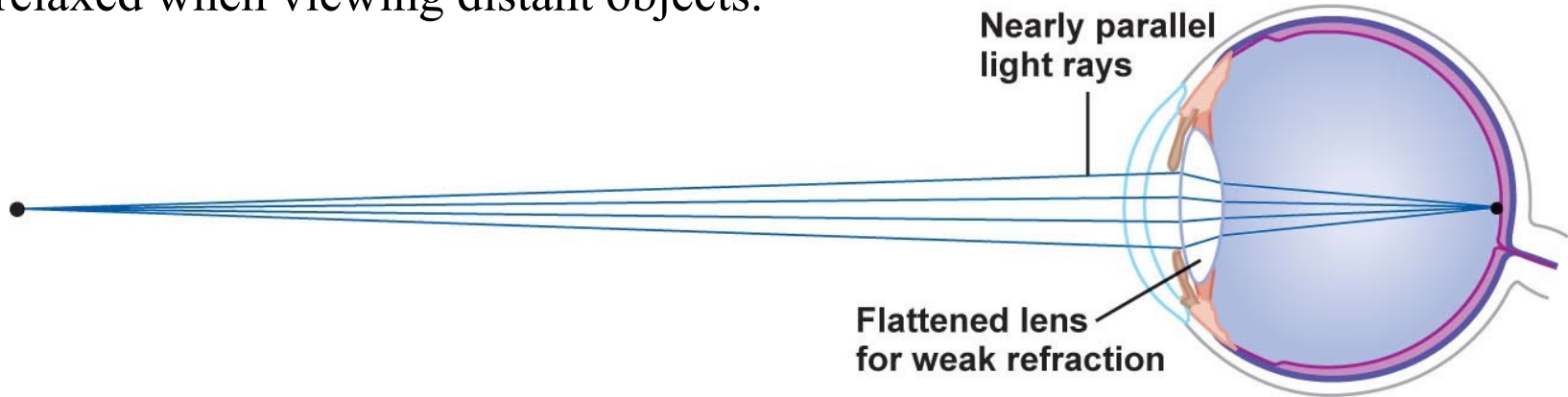

**(a) Viewing a distant object**

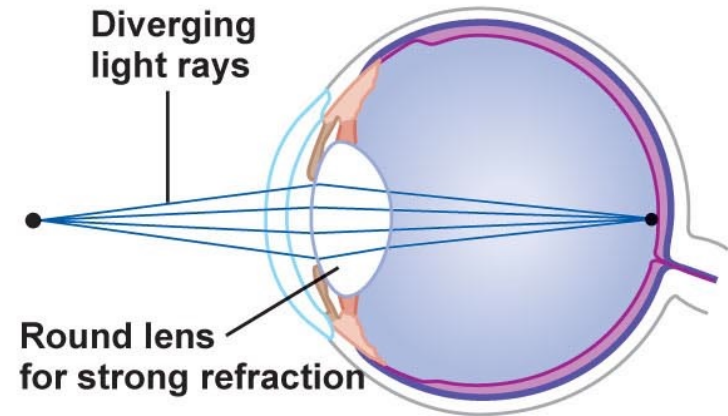

**(b) Viewing a near object**

# Telescope Inner Workings

---

- ◆ Light collected by a telescope is diverted into a narrower column of parallel rays before entering the eye. **Is it necessary to present parallel rays to the eye? Why not place the eye beyond the focal point where the rays diverge, avoiding the need for an eyepiece?**

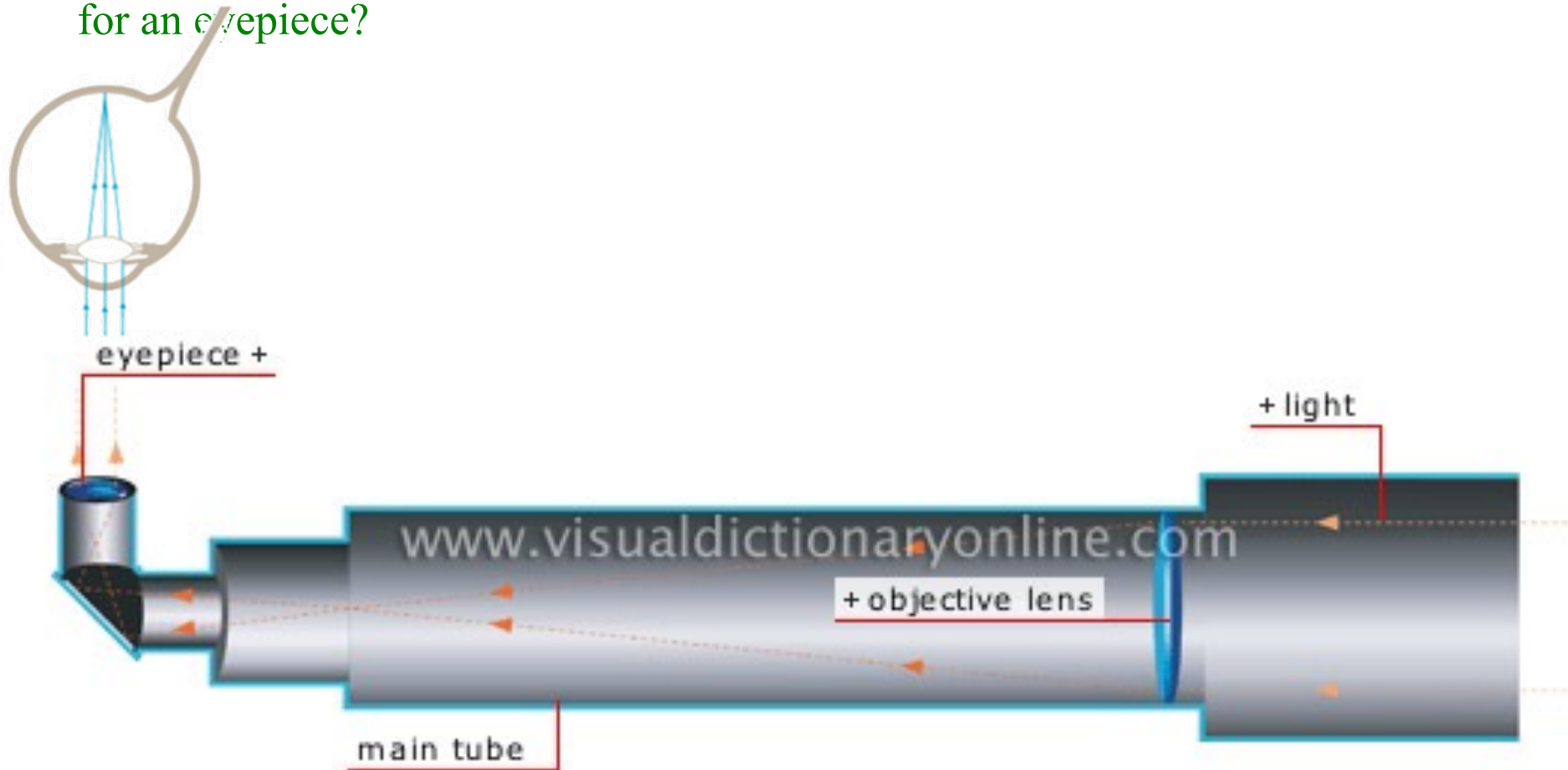



# Telescope Inner Workings

- ◆ Light collected by a telescope is diverted into a narrower column of parallel rays before entering the eye. Is it necessary to present parallel rays to the eye? Why not place the eye beyond the focal point where the rays diverge, avoiding the need for an eyepiece?

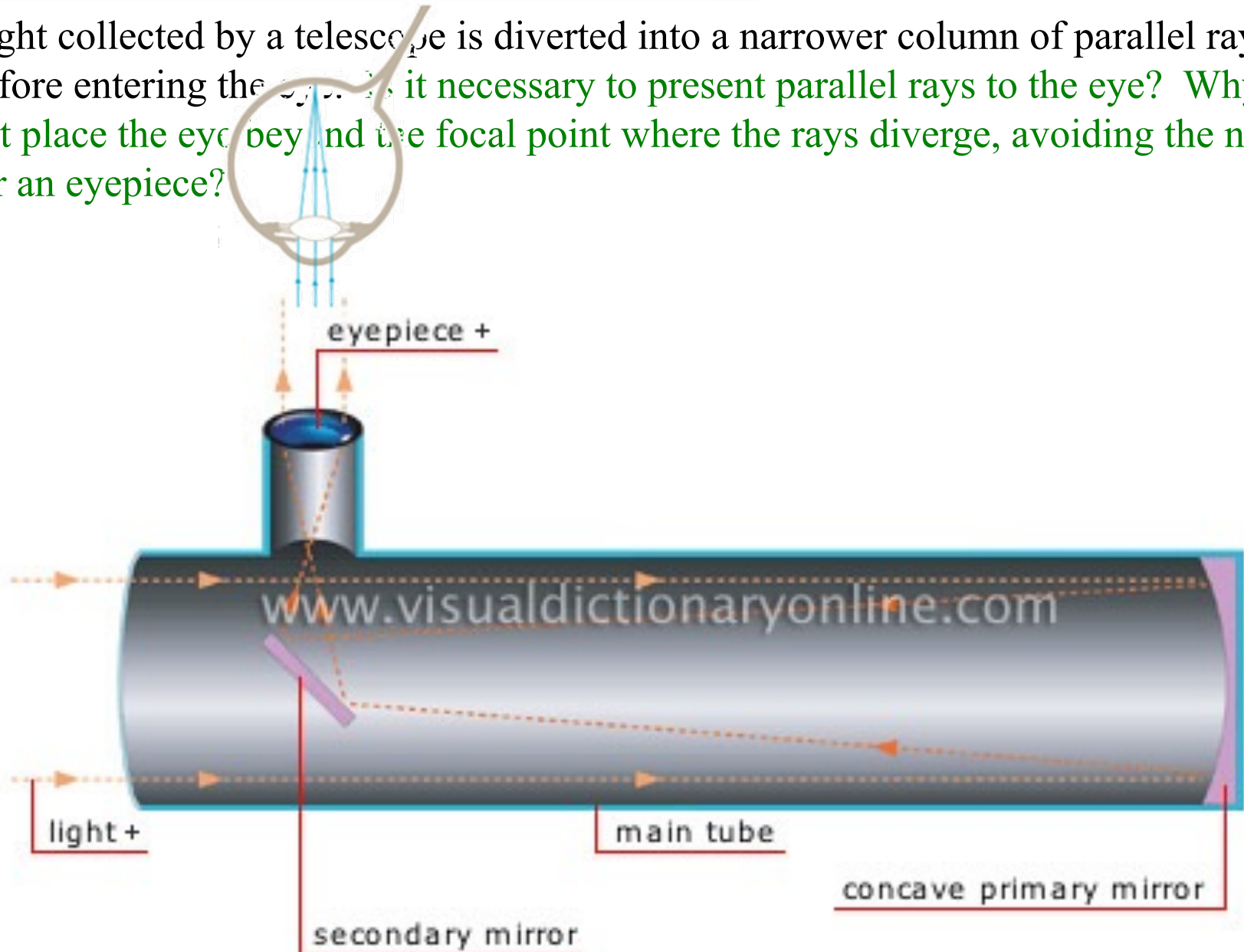

# Telescope Inner Workings

- ◆ Light collected by a telescope is diverted into a narrower column of parallel rays before entering the eye. **Is it necessary to present parallel rays to the eye? Why not place the eye beyond the focal point where the rays diverge, avoiding the need for an eyepiece? If light rays too strongly divergent, eye cannot focus, and not all the light collected by the telescope may enter the eye. If parallel rays, eye most relaxed, and also maximizes light collected by the eye. (There is another important reason for using an eyepiece for viewing, which we will return to later.)**

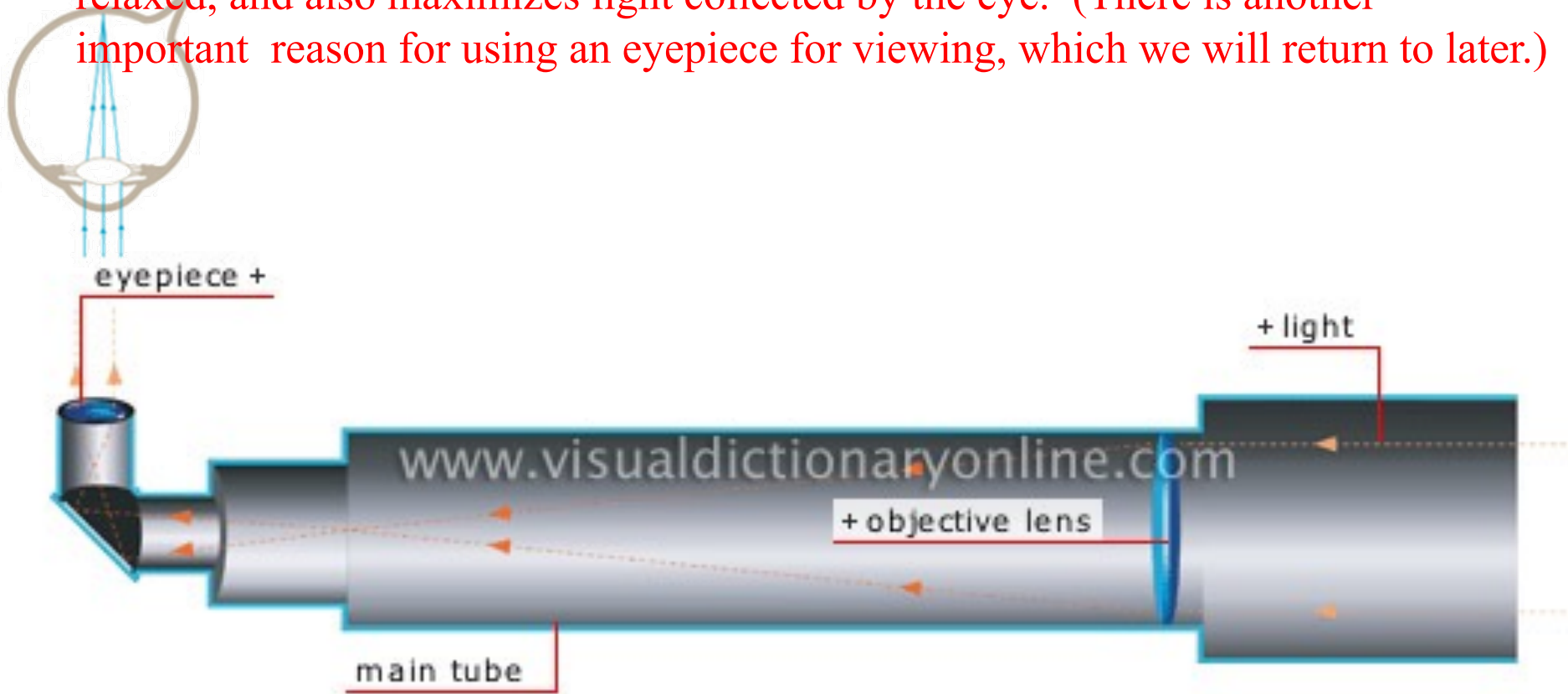

# Telescope Inner Workings

- ◆ For photography in amateur telescopes or in professional telescopes, a camera can be used in place of the eye. There is another (better) way to do astrophotography, as explained later.

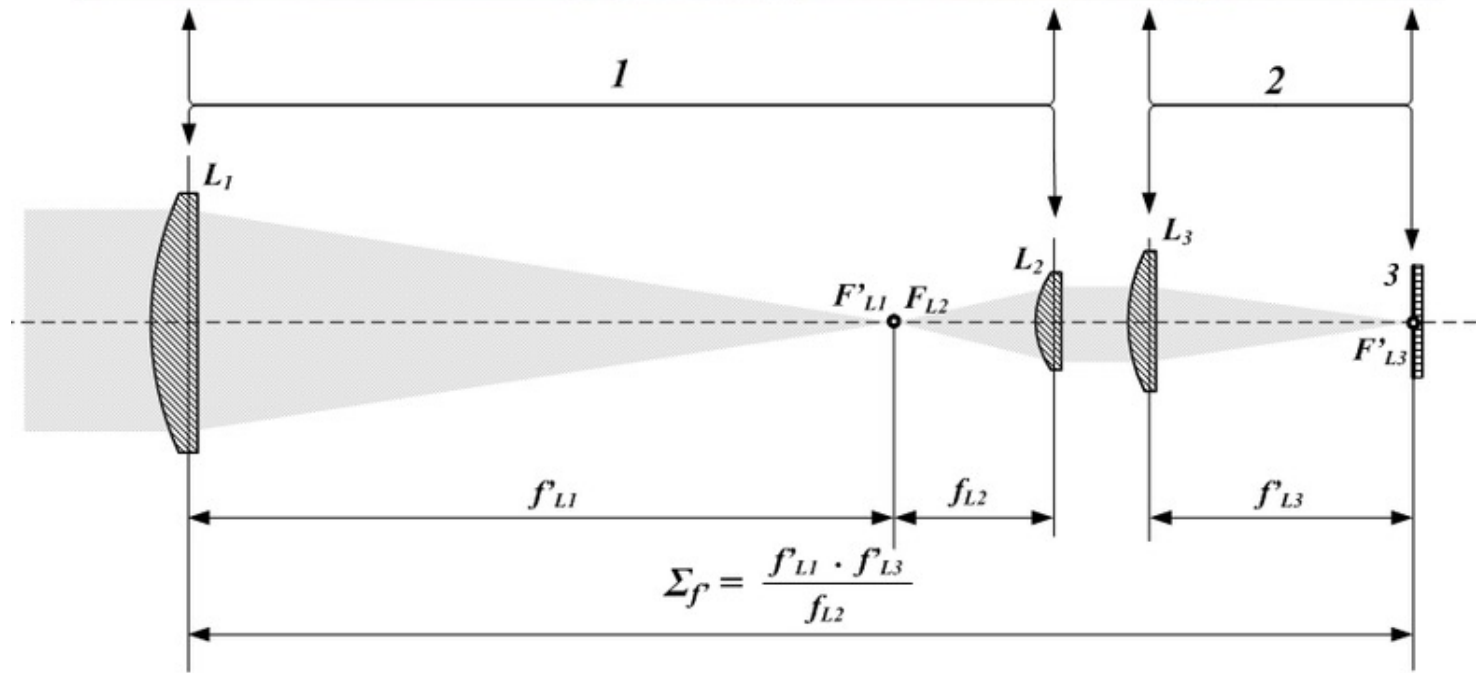

# Telescope Functions

---

- ◆ Three main functions of telescopes:
  - light collectors

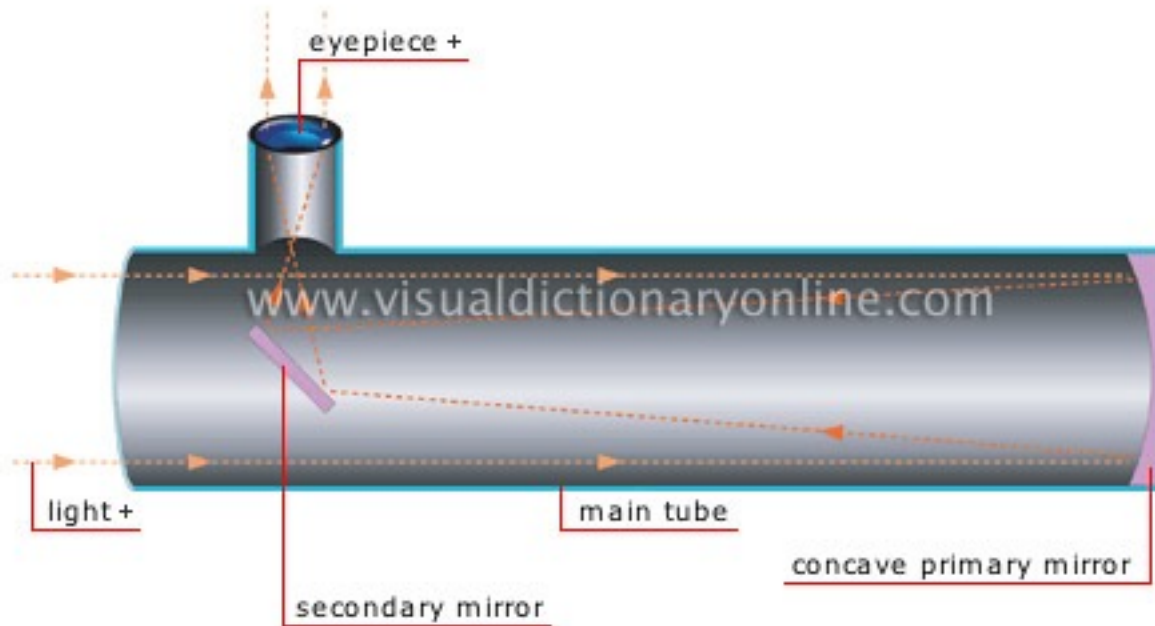
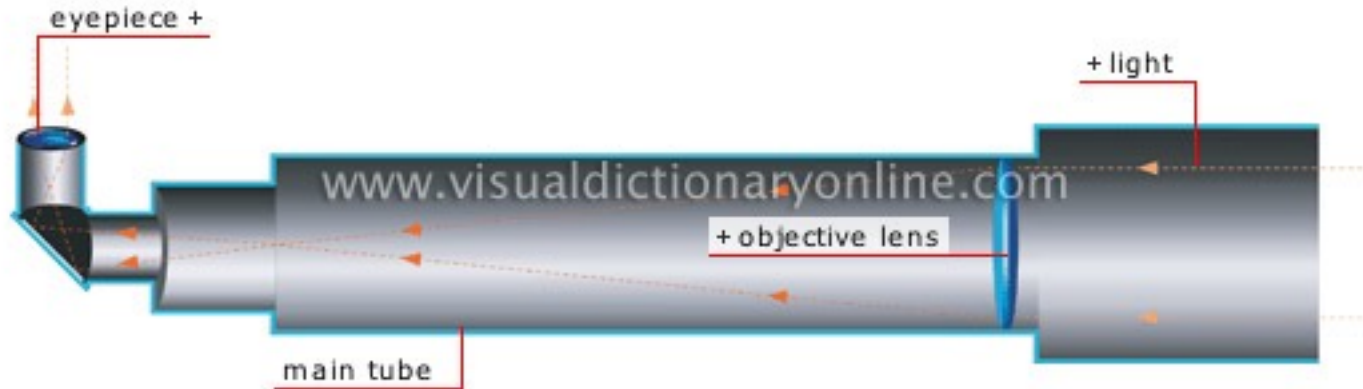

# Telescope Functions

---

- ◆ Three main functions of telescopes:
  - light collectors
- ◆ How much more light is collected by the Yerkes telescope, or the Gran Telescopio Canarias, compared to the human eye? For this exercise, assume a diameter for the human eye pupil of 10 mm.



1.02-m Yerkes Telescope



10.4-m Gran Telescopio Canarias

---

The sizes of telescopes refer to the diameter of their primary objective

# Telescope Functions

---

- ◆ Three main functions of telescopes:
  - light collectors
- ◆ How much more light is collected by the Yerkes telescope, or the Gran Telescopio Canarias, compared to the human eye? For this exercise, assume a diameter for the human eye of 10 mm.  $\sim 100^2 = 10,000$  times for Yerkes,  $\sim 1000^2 = 1,000,000$  times for Gran Telescopio Canarias.



1.02-m Yerkes Telescope



10.4-m Gran Telescopio Canarias

---

The sizes of telescopes refer to the diameter of their primary objective

# Telescope Functions

---

- ◆ Three main functions of telescopes:
  - light collectors
  - angular magnification



# Telescope Functions

---

- ◆ Three main functions of telescopes:
  - light collectors
  - angular magnification, but do not sharpen features

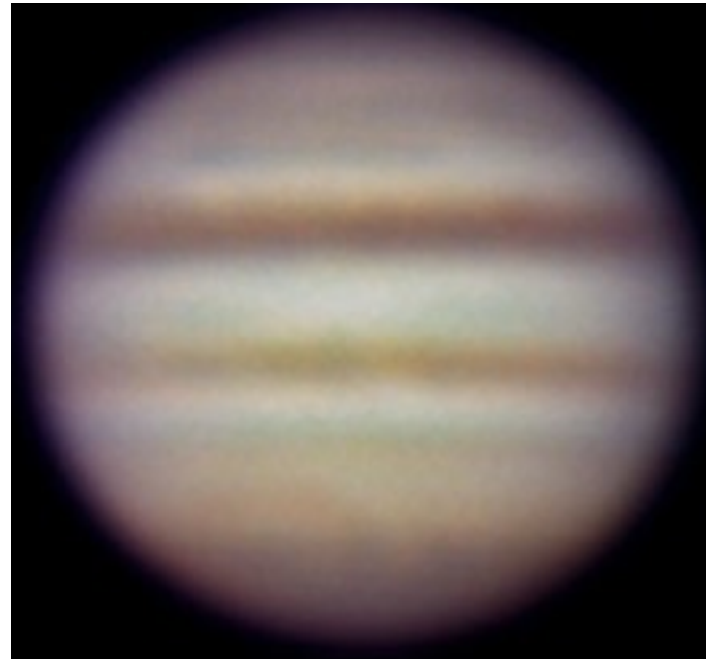
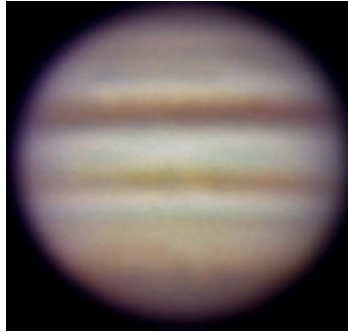
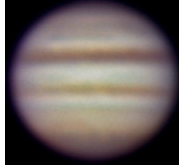



# Telescope Functions

---

- ◆ Three main functions of telescopes:
  - light collectors
  - angular magnification, but do not sharpen features. For example, the face of this person (taken with a CCTV camera) will be no more recognizable no matter how much the image is magnified.



# Telescope Functions

---

- ◆ Three main functions of telescopes:
  - light collectors
  - angular magnification
  - higher resolution
- ◆ Do not confuse magnification with higher resolution. Magnification make objects look larger, but does not allow us to perceive finer details in the object. Higher resolution allows us to perceive finer details in the object even at the same magnification.

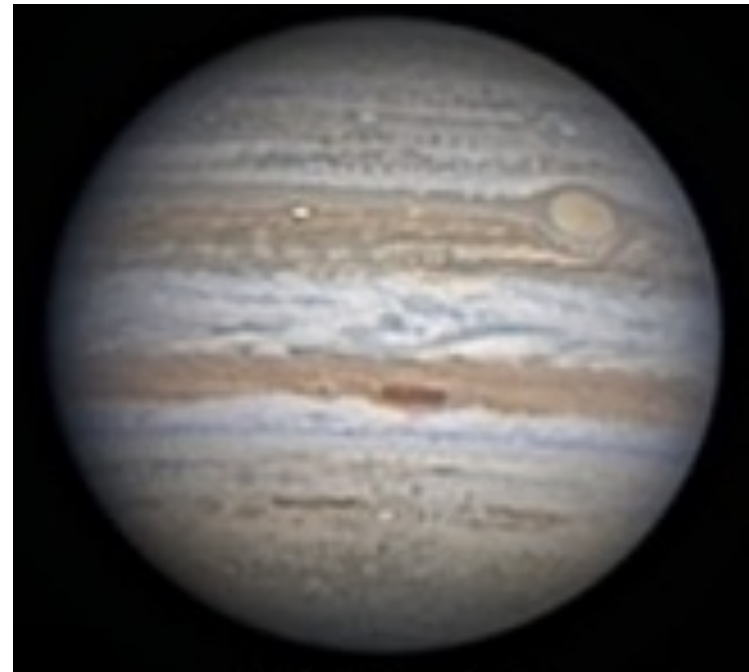
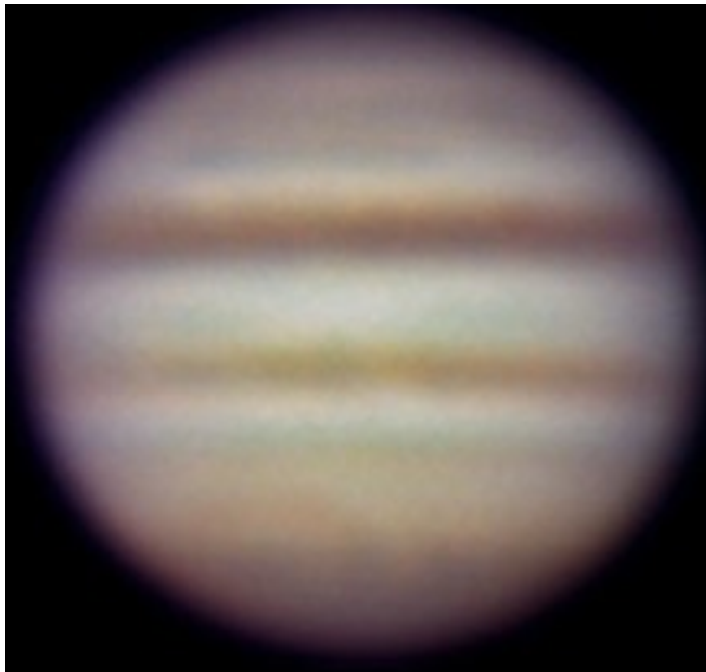

# Telescope Functions

---

- ◆ Three main functions of telescopes:
  - light collectors
  - angular magnification
  - higher resolution

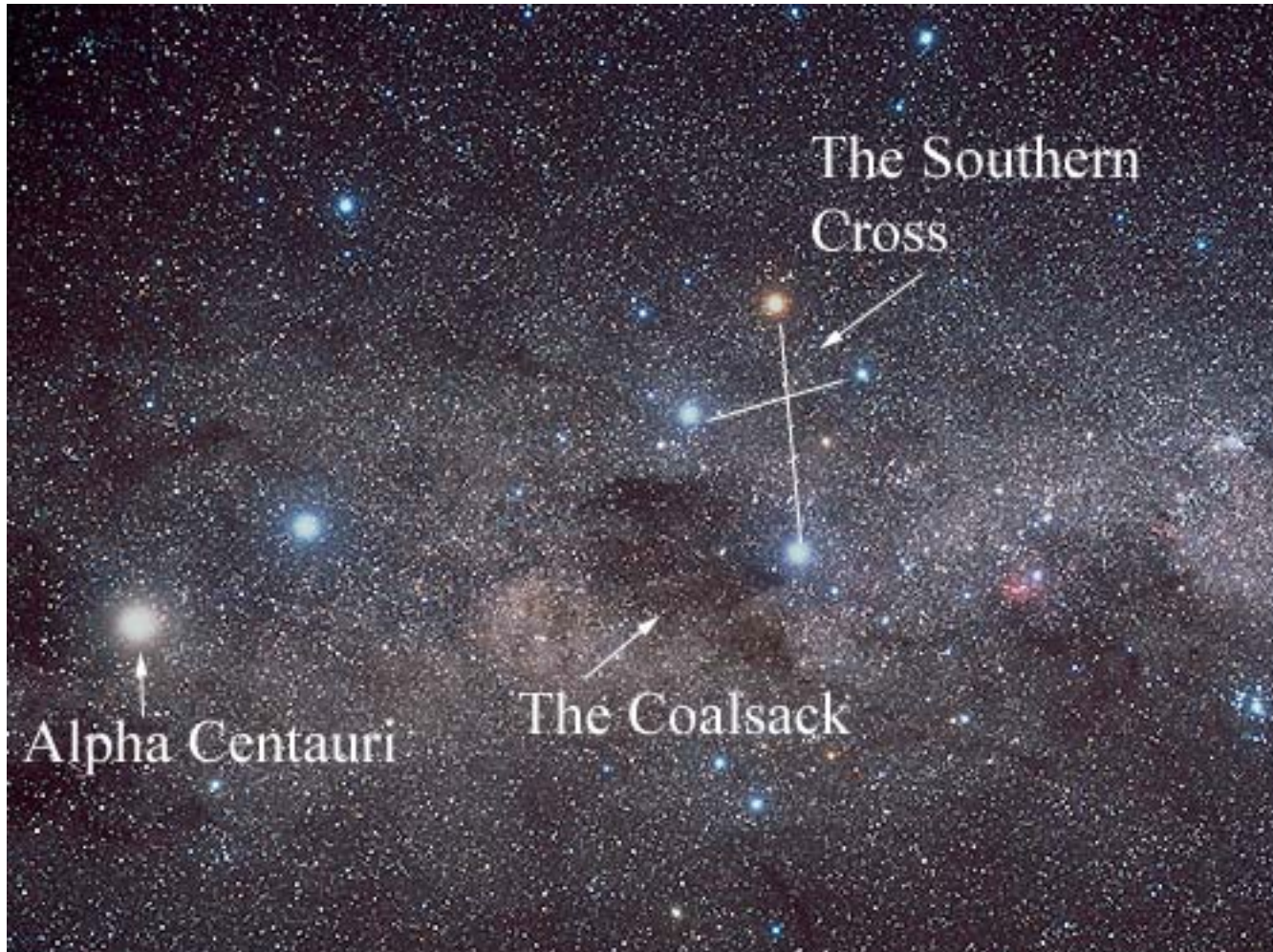

# Telescope Functions

---

- ◆ Three main functions of telescopes:
  - light collectors
  - angular magnification
  - higher resolution
- ◆ Do not confuse magnification with higher resolution. Magnification make objects look larger (e.g., magnification increases the size of a star from a point to a blob), but does not allow us to perceive finer details in the object (e.g., that the single blob actually comprises two stars).

## Alpha Centauri

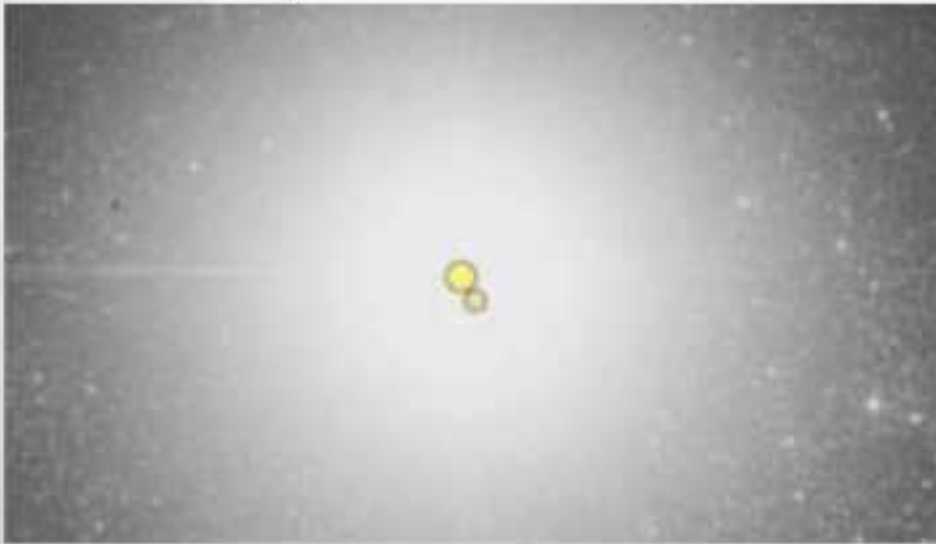

# Learning Objectives

---

- ◆ Telescopes:
  - main types, primary components, and inner workings
  - primary functions
- ◆ Review of Basic Optics:
  - lens and mirror formulae
  - photography versus viewing
  - linear magnification
- ◆ Telescope Optics:
  - focal ratio
  - image size and plate scale
  - field of view at focal plane
  - angular magnification through eyepiece
  - true vs. apparent field of view of eyepiece
  - exit pupil

# Basic Optics

---

- ◆ Lenses refract (bend) light. Below is an example of a converging lens.

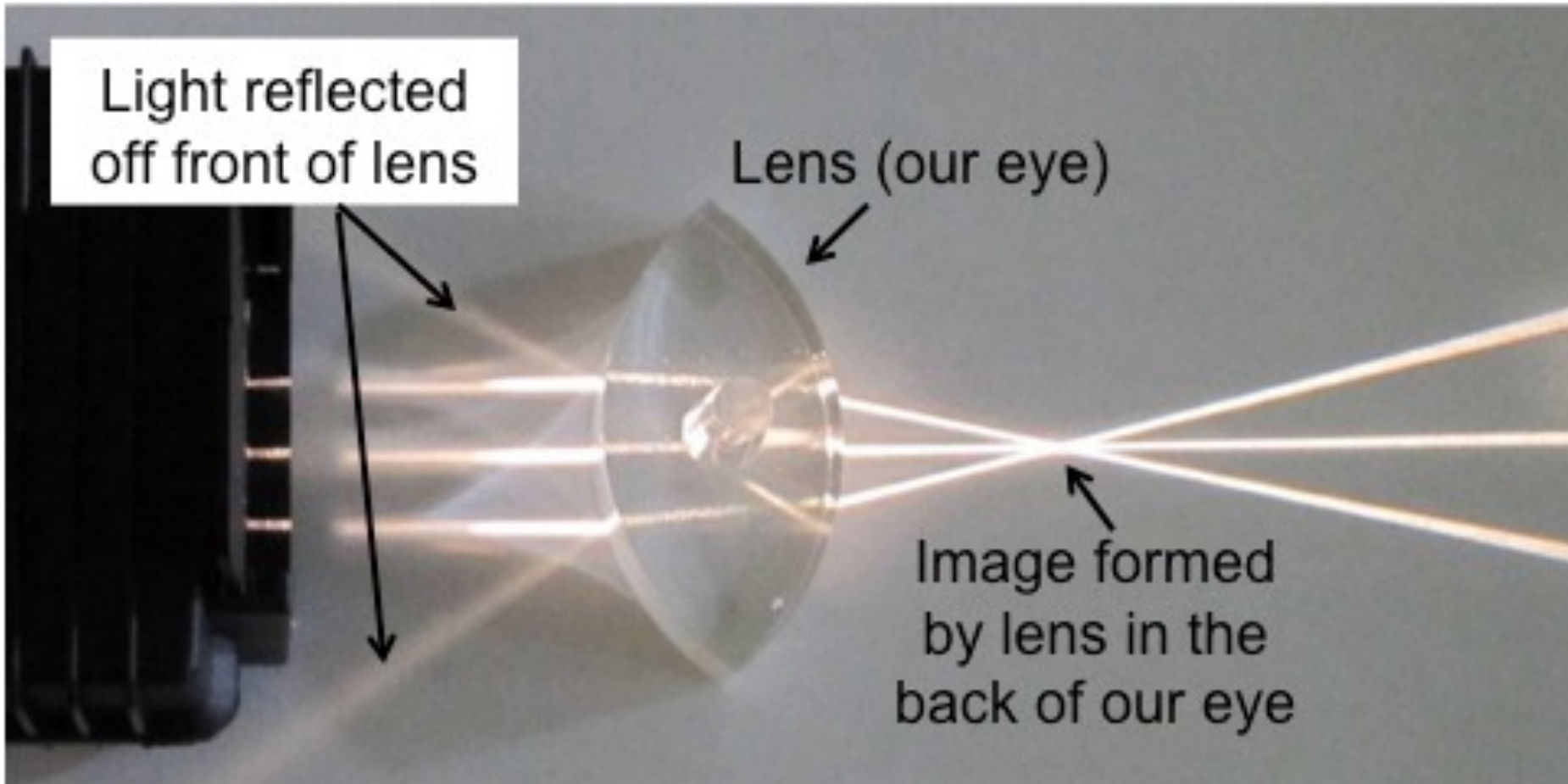

# Basic Optics

---

- ◆ Lenses refract (bend) light. Below is an example of a diverging lens.

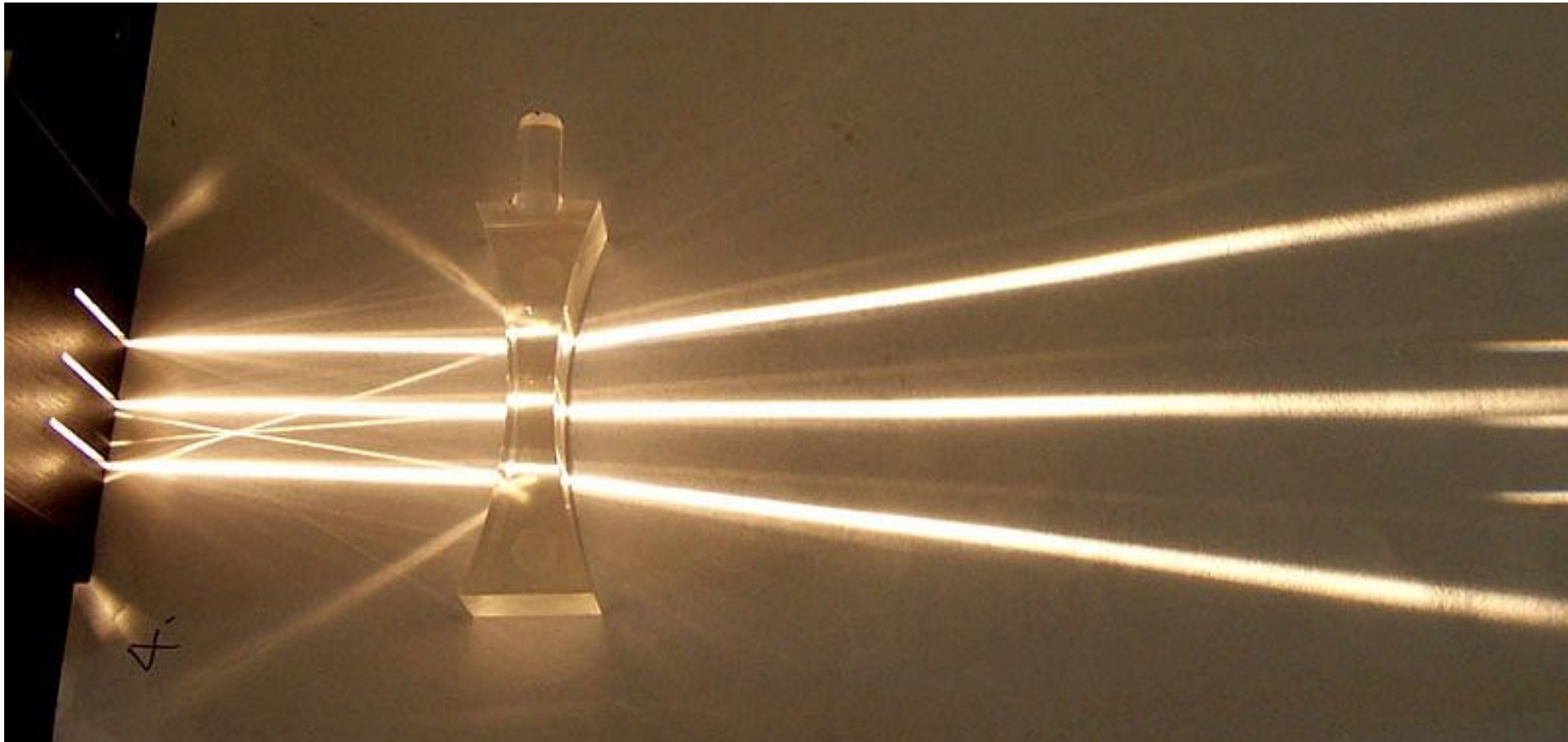

# Basic Optics

---

- ◆ Lenses can be grouped into converging or diverging lenses. Within each group, there are many different types of lenses.

converging lenses



biconvex



plano  
convex



convex  
meniscus

Thicker at center  
than periphery

diverging lenses

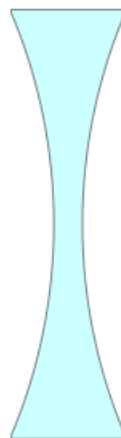

biconcave



plano  
concave



concave  
meniscus

Thicker at periphery  
than center

- ◆ What type of lenses are used in spectacles?



# Basic Optics

---

- ◆ Lenses can be grouped into converging or diverging lenses. Within each group, there are many different types of lenses.

converging lenses

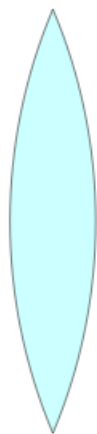

biconvex



plano  
convex



convex  
meniscus

Thicker at center  
than periphery

diverging lenses

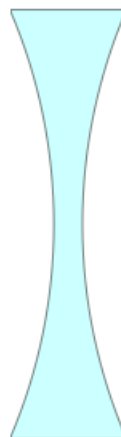

biconcave



plano  
concave

Thicker at periphery  
than center



concave  
meniscus

- ◆ What type of lenses are used in spectacles? **Concave meniscus (nearsighted) or convex meniscus (farsighted).**

# Basic Optics

---

- ◆ Diverging lenses are used to correct for nearsightedness.

## Nearsightedness and its correction

Diverging light from a single point.

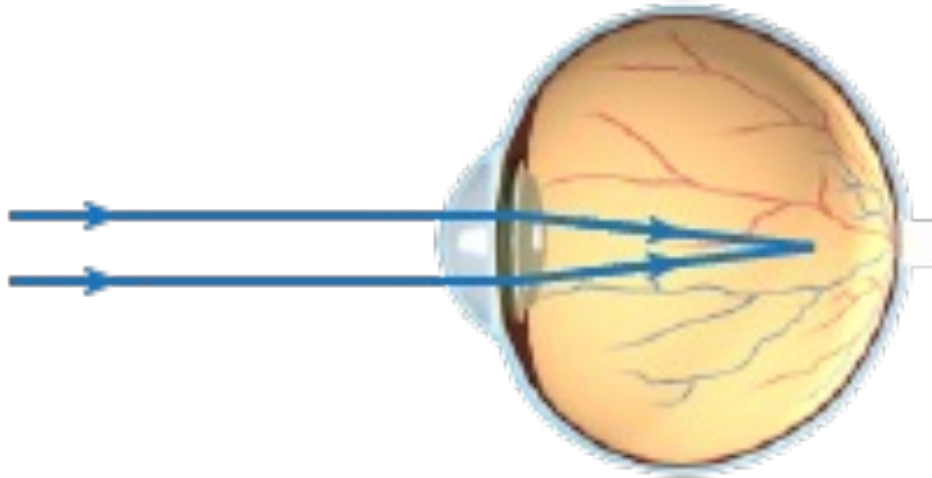

Nearsighted eyes focus light in front of retina.

Concave meniscus

Diverging light from a single point.

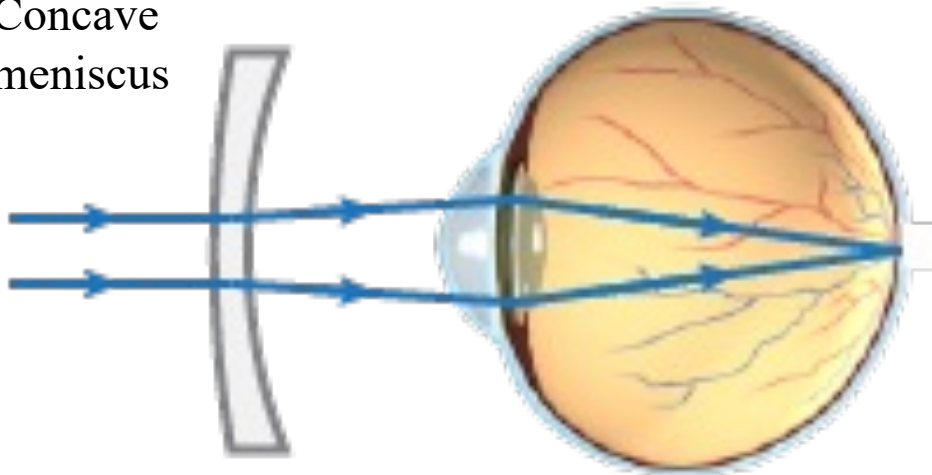

Diverging lens corrector moves focus backwards.

# Basic Optics

---

- ◆ Converging lenses are used to correct for farsightedness.

## Farsightedness and its correction

Diverging light from a single point.

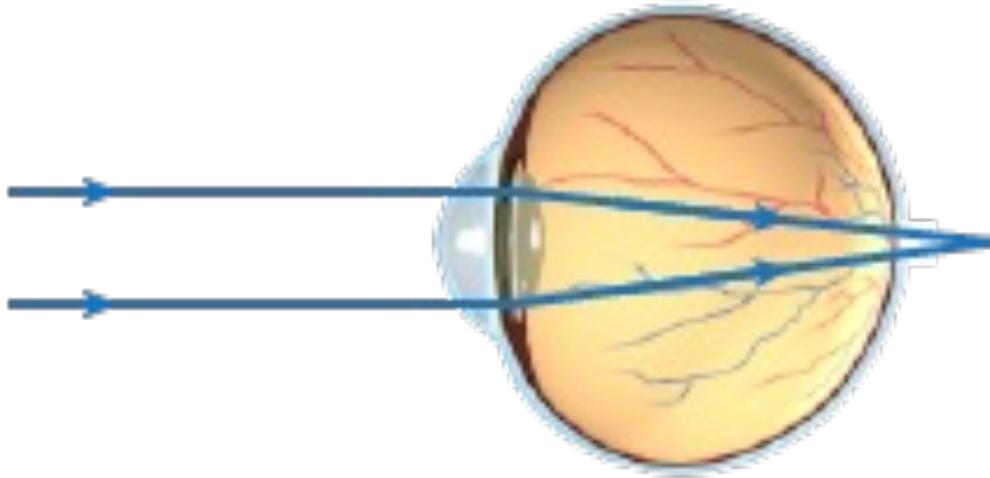

**Farsighted eyes focus light behind retina.**

Convex meniscus

Diverging light from a single point.

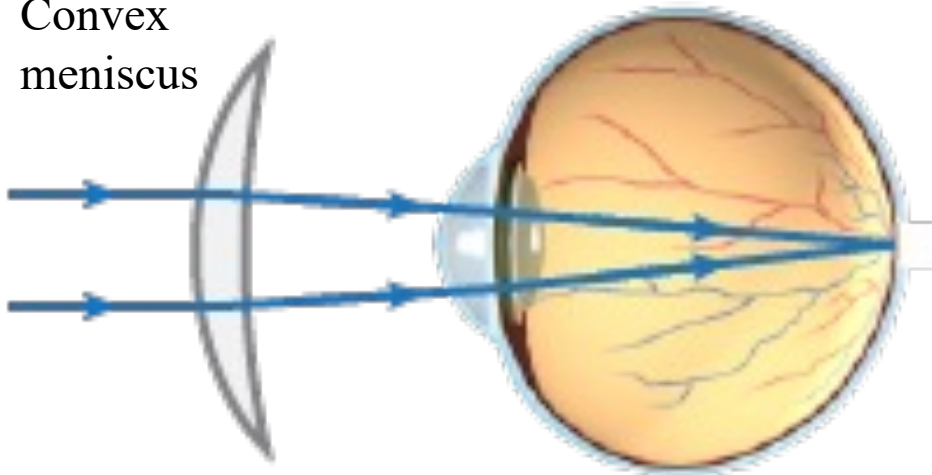

**Converging lens corrector moves focus forwards.**

# Basic Optics

---

- ◆ If the thickness of the lens is much smaller than the radii of curvature at its two surfaces ( $d \ll R_1, R_2$ ),

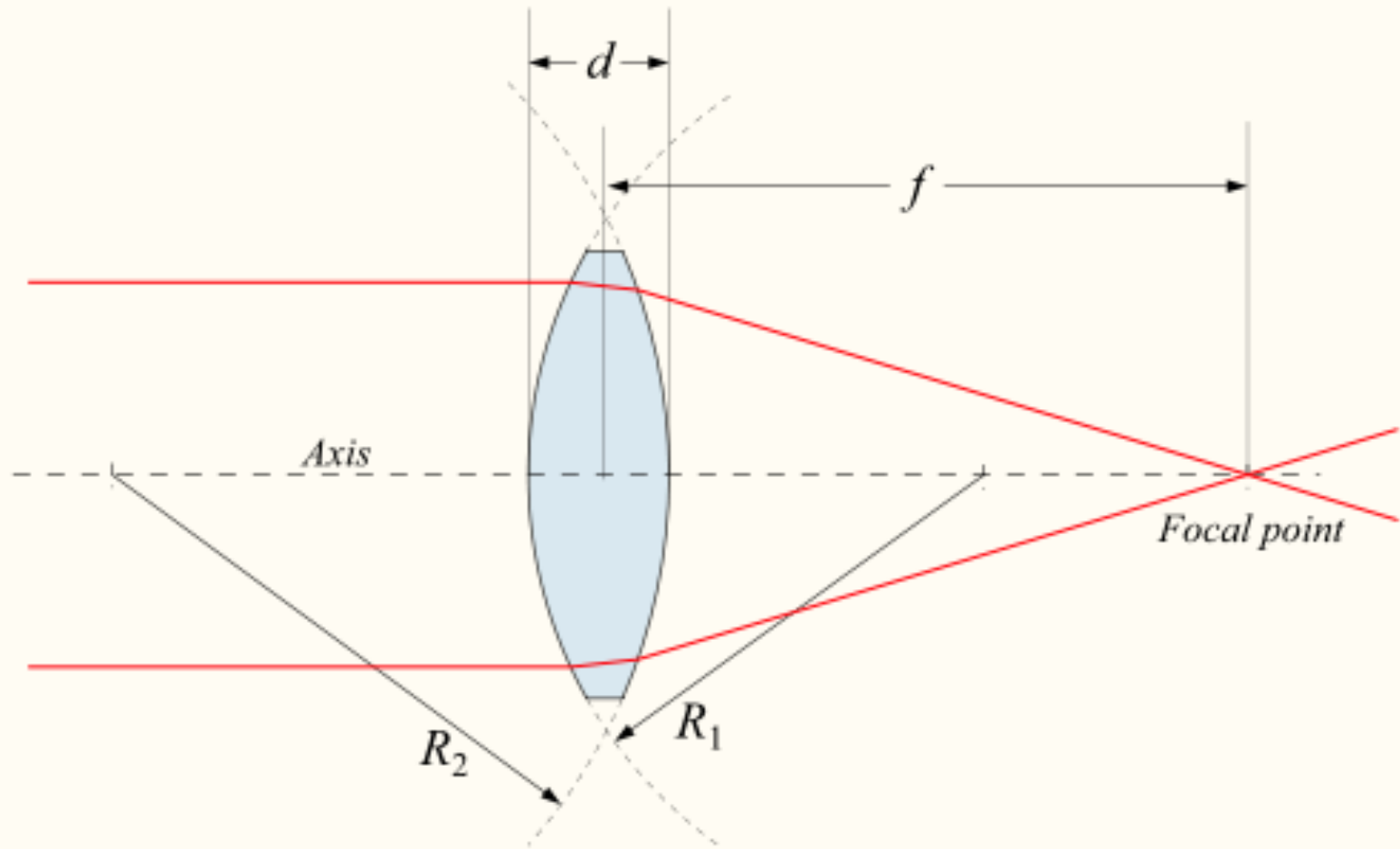

*Positive (converging) lens*

# Basic Optics

- ◆ If the thickness of the lens is much smaller than the radii of curvature at its two surfaces ( $d \ll R_1, R_2$ ),

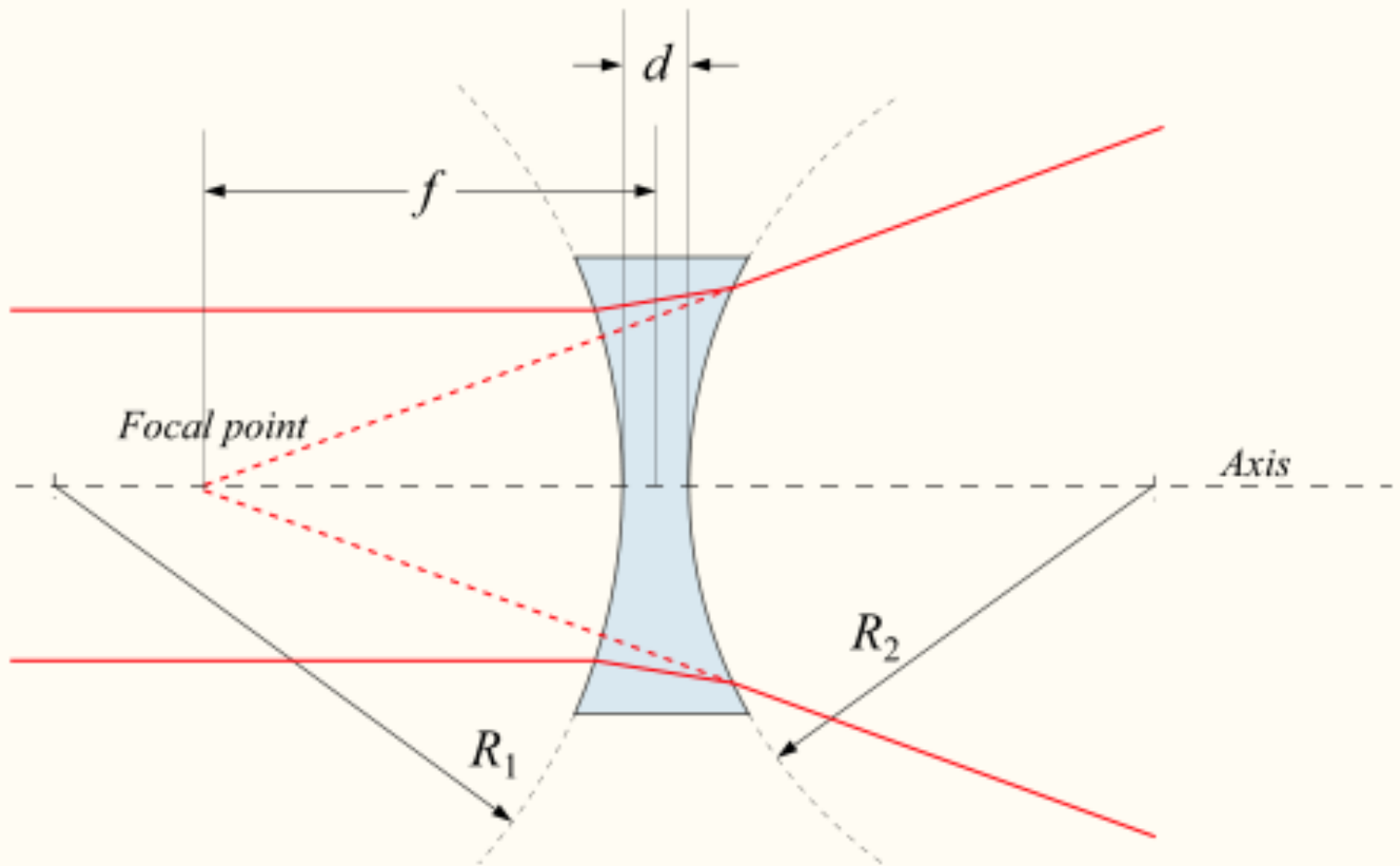

*Negative (diverging) lens*

# Basic Optics

---

- ◆ If the thickness of the lens is much smaller than the radii of curvature at its two surfaces ( $d \ll R_1, R_2$ ), we can use the **thin lens formula** (in the case where  $R_1=R_2$ )

$$\frac{1}{o} + \frac{1}{i} = \frac{1}{f}$$

where  $o$  = object distance from lens (+ve)

$i$  = image distance from lens (+ve in direction of light travel)

$f$  = focal length of lens (+ve in direction of light travel)

- ◆ To determine where the image forms, draw the following light rays.

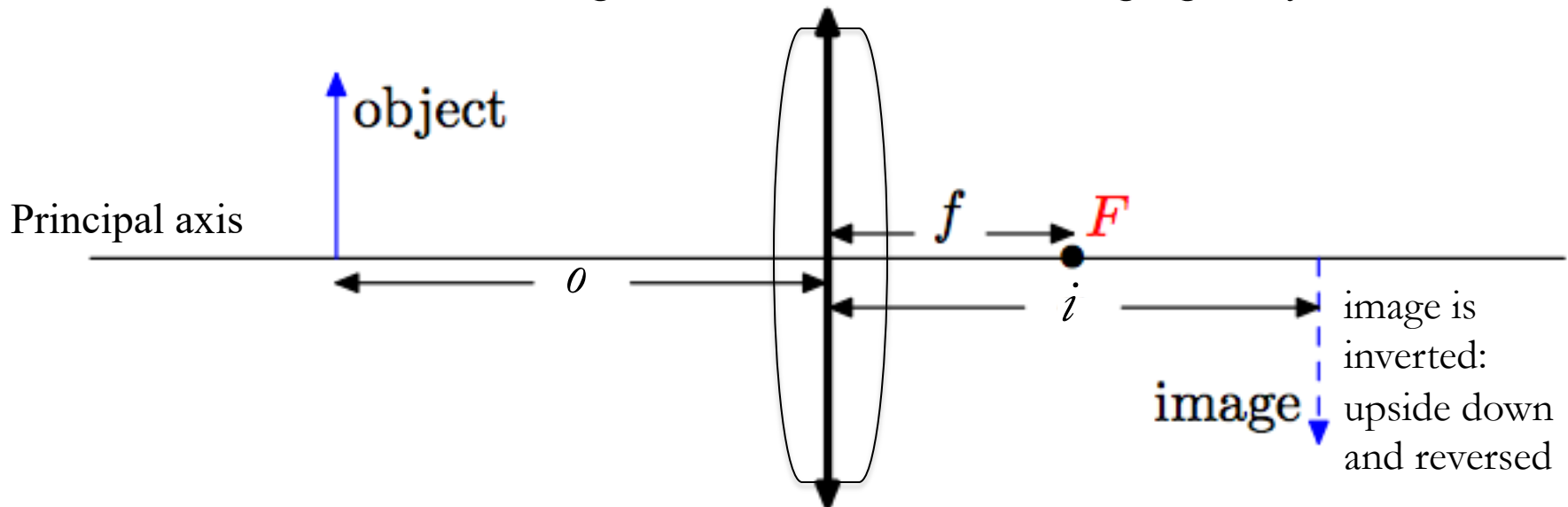

# Basic Optics

---

- ◆ If the thickness of the lens is much smaller than the radii of curvature at its two surfaces ( $d \ll R_1, R_2$ ), we can use the **thin lens formula** (in the case where  $R_1=R_2$ )

$$\frac{1}{o} + \frac{1}{i} = \frac{1}{f}$$

where  $o$  = object distance from lens (+ve)

$i$  = image distance from lens (+ve in direction of light travel)

$f$  = focal length of lens (+ve in direction of light travel)

- ◆ A ray parallel to the principal axis deflects at the lens axis and passes through the focus.

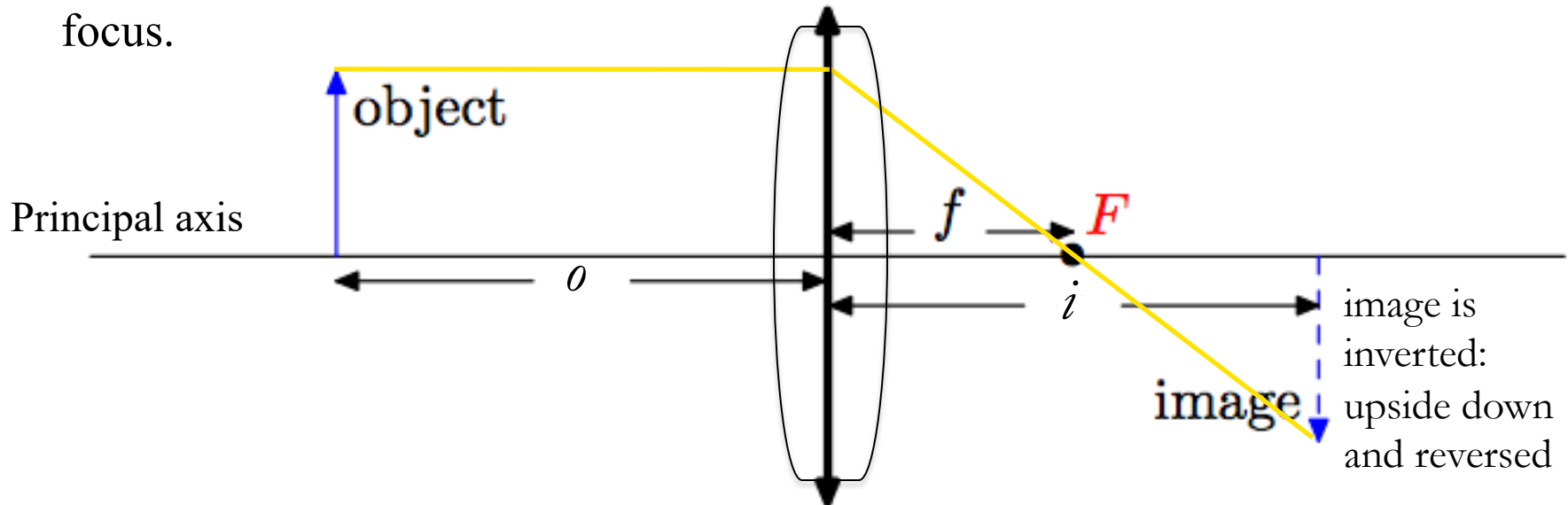

# Basic Optics

---

- ◆ If the thickness of the lens is much smaller than the radii of curvature at its two surfaces ( $d \ll R_1, R_2$ ), we can use the **thin lens formula** (in the case where  $R_1=R_2$ )

$$\frac{1}{o} + \frac{1}{i} = \frac{1}{f}$$

where  $o$  = object distance from lens (+ve)

$i$  = image distance from lens (+ve in direction of light travel)

$f$  = focal length of lens (+ve in direction of light travel)

- ◆ A ray passing through the center of the lens emerges undeviated. An image forms at the intersection of these two rays.

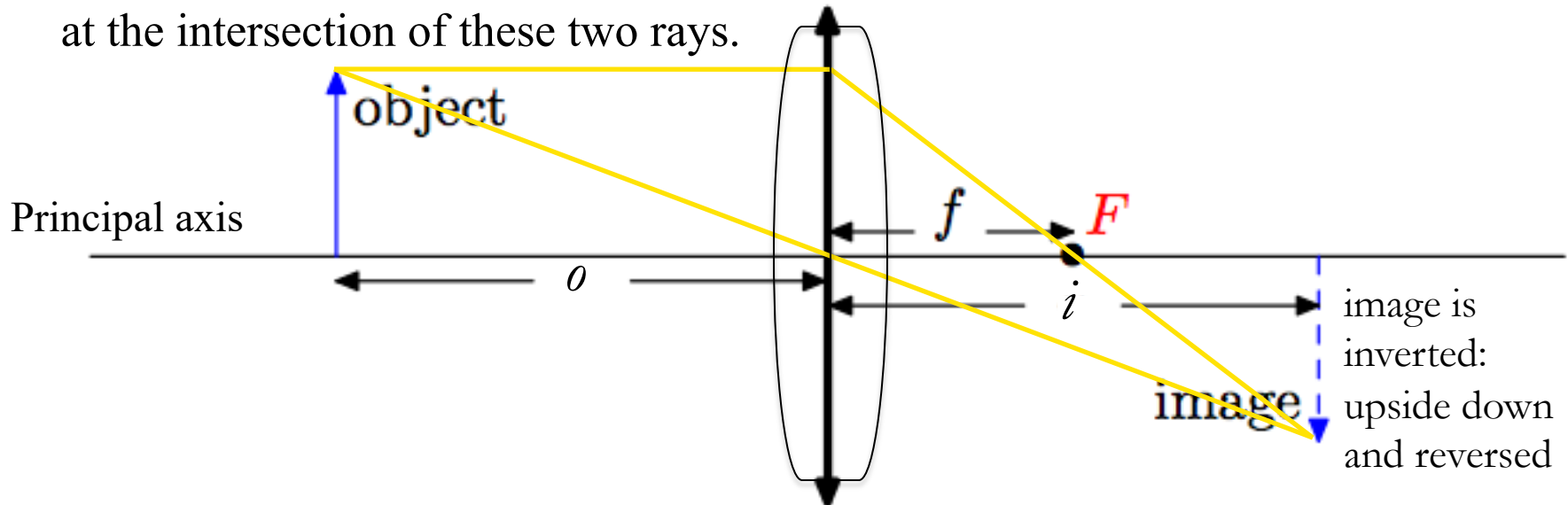



# Basic Optics

- ◆ If the thickness of the lens is much smaller than the radii of curvature at its two surfaces ( $d \ll R_1, R_2$ ), we can use the **thin lens formula** (in the case where  $R_1=R_2$ )

$$\frac{1}{o} + \frac{1}{i} = \frac{1}{f}$$

where  $o$  = object distance from lens (+ve)  
 $i$  = image distance from lens (+ve in direction of light)  
 $f$  = focal length of lens (+ve in direction of light)

- ◆ If the image can be projected on a screen, it is a real image. In this case, the image is inverted.

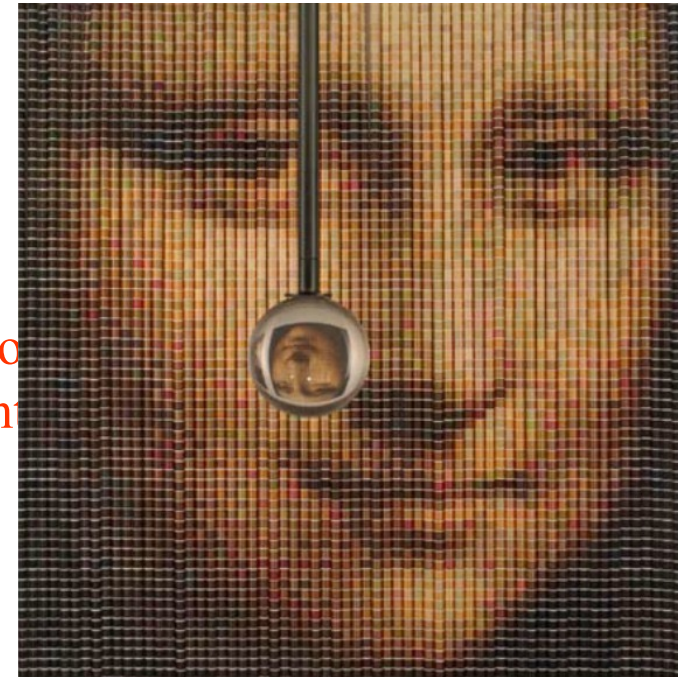
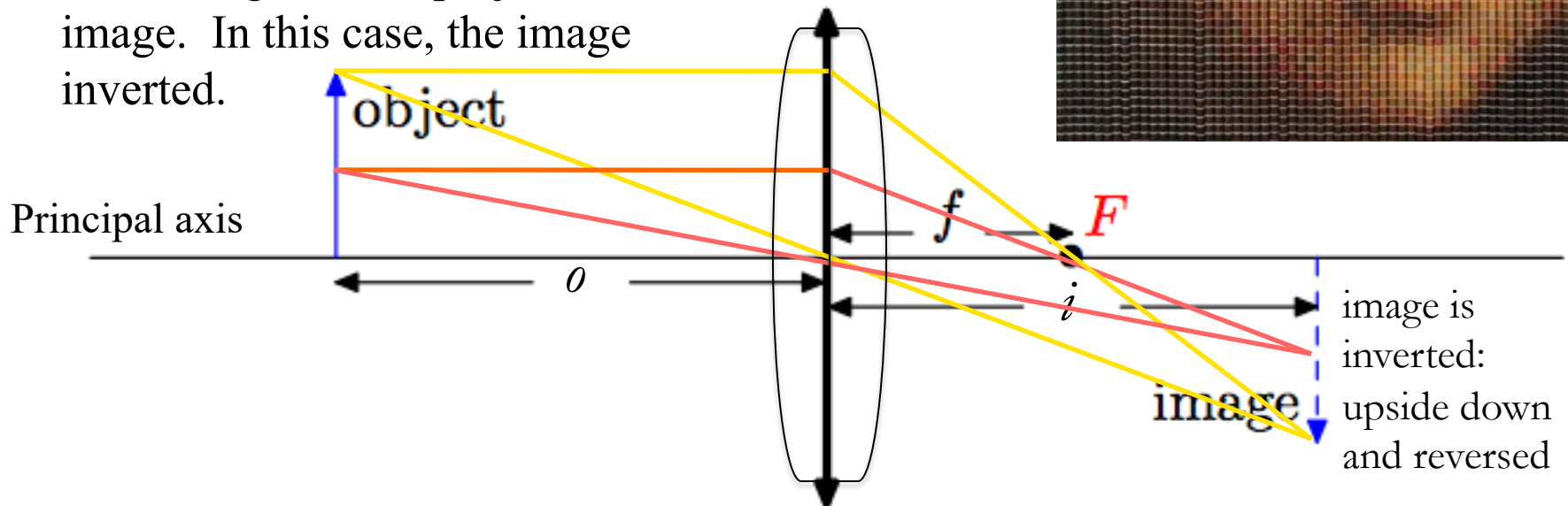

# Basic Optics

- ◆ If the thickness of the lens is much smaller than the radii of curvature at its two surfaces ( $d \ll R_1, R_2$ ), we can use the **thin lens formula** (in the case where  $R_1=R_2$ )

$$\frac{1}{o} + \frac{1}{i} = \frac{1}{f}$$

where  $o$  = object distance from lens (+ve)  
 $i$  = image distance from lens (+ve in direction of light)  
 $f$  = focal length of lens (+ve in direction of light)

- ◆ If the image can be projected on a screen, it is a real image. In this case, the image is inverted.

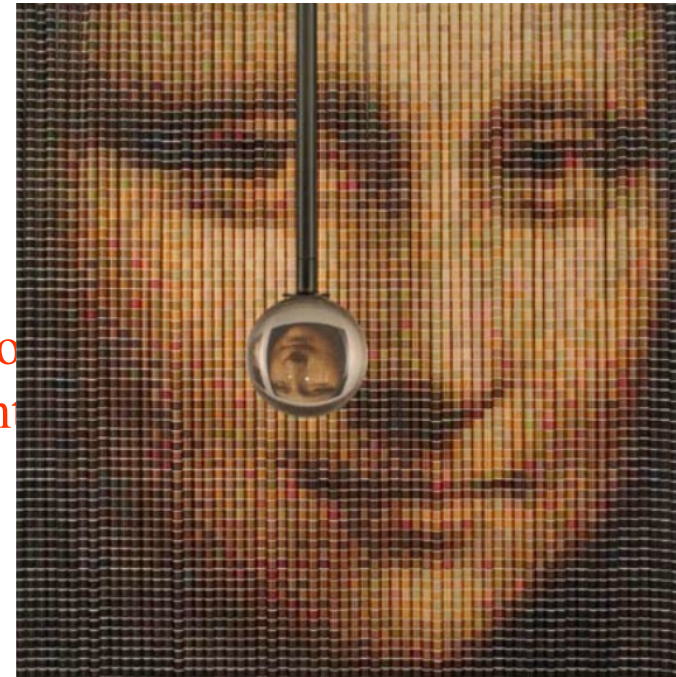
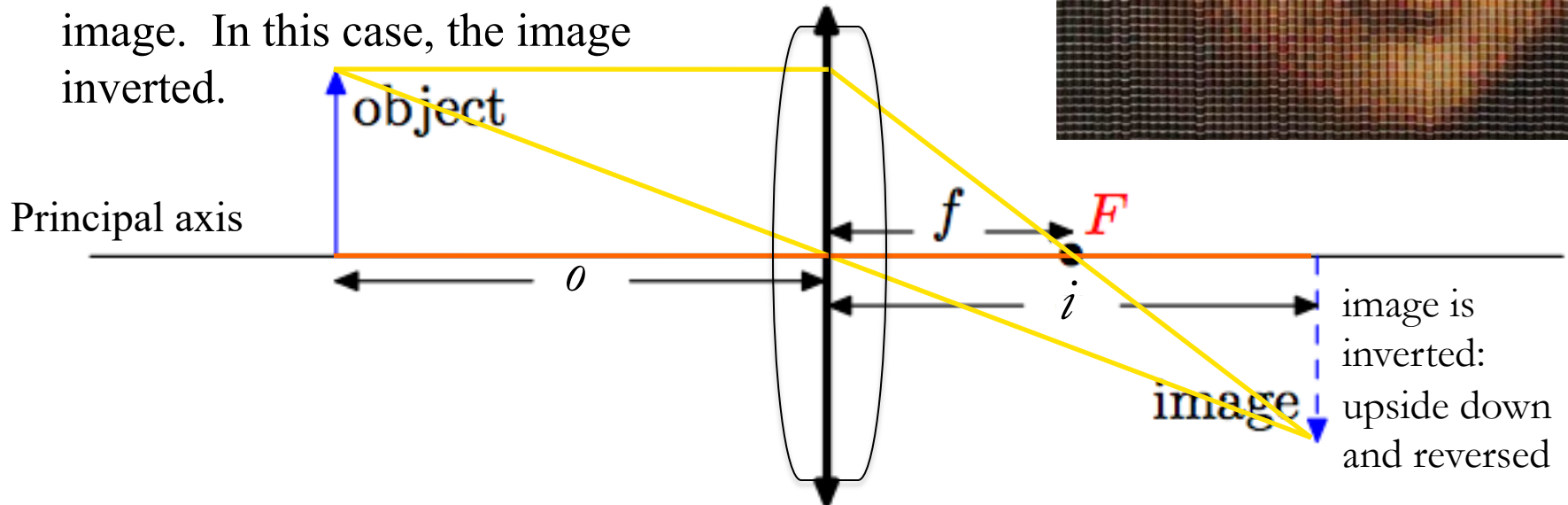

# Basic Optics

- ◆ If the thickness of the lens is much smaller than the radii of curvature at its two surfaces ( $d \ll R_1, R_2$ ), we can use the **thin lens formula** (in the case where  $R_1=R_2$ )

$$\frac{1}{o} + \frac{1}{i} = \frac{1}{f}$$

where  $o$  = object distance from lens (+ve)  
 $i$  = image distance from lens (+ve in direction of light)  
 $f$  = focal length of lens (+ve in direction of light)

- ◆ If the image can be projected on a screen, it is a real image. In this case, the image is inverted.

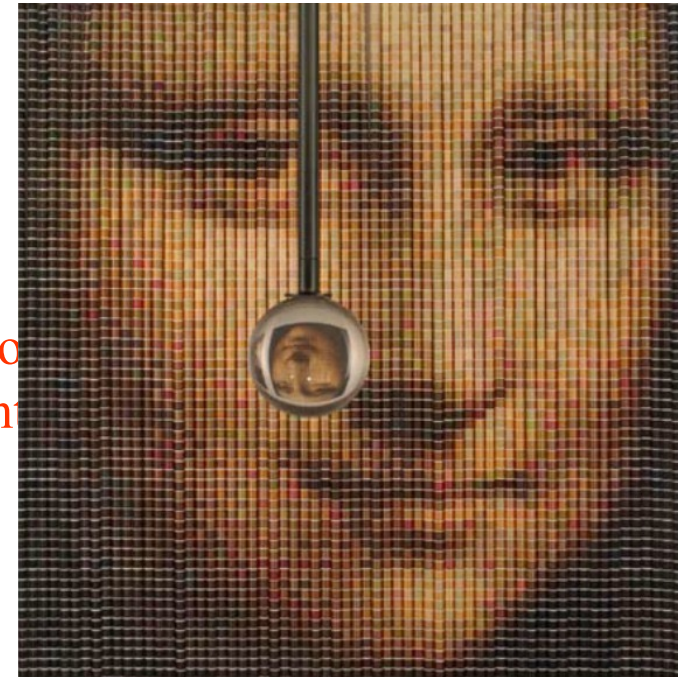
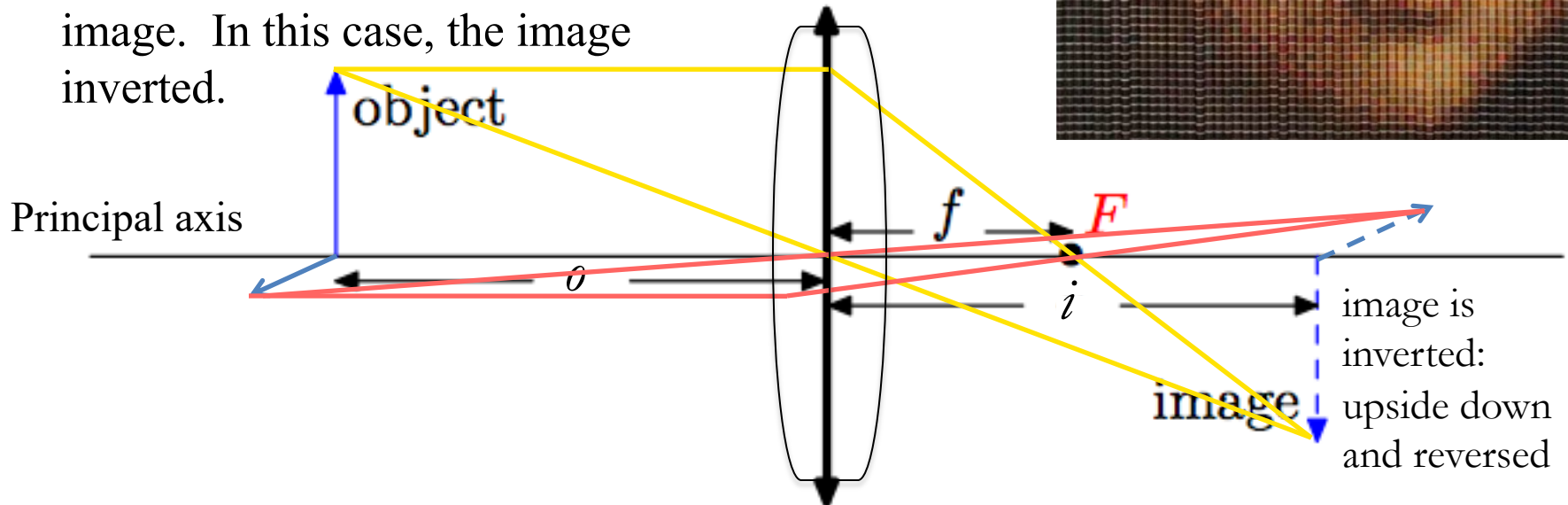

# Basic Optics

- ◆ If the thickness of the lens is much smaller than the radii of curvature at its two surfaces ( $d \ll R_1, R_2$ ), we can use the **thin lens formula** (in the case where  $R_1=R_2$ )

$$\frac{1}{o} + \frac{1}{i} = \frac{1}{f}$$

where  $o$  = object distance from lens (+ve)  
 $i$  = image distance from lens (+ve in direction of light)  
 $f$  = focal length of lens (+ve in direction of light)

- ◆ If the image can be projected on a screen, it is a real image. In this case, the image is inverted.

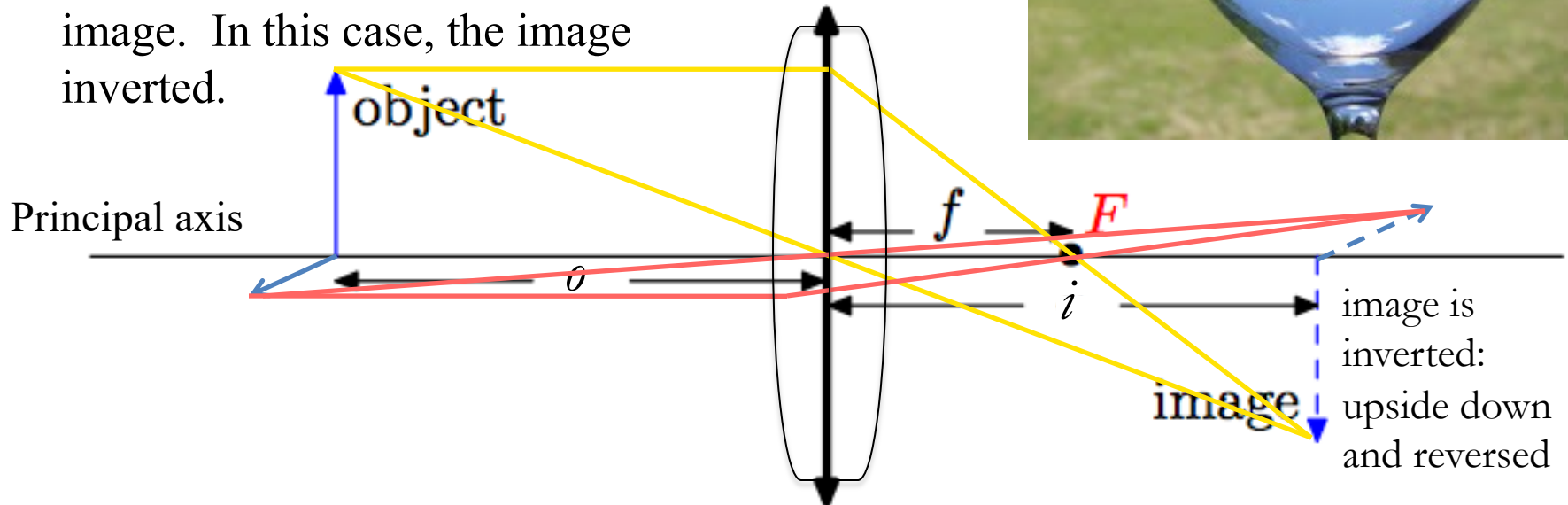

# Basic Optics

---

- ◆ If the thickness of the lens is much smaller than the radii of curvature at its two surfaces ( $d \ll R_1, R_2$ ), we can use the **thin lens formula** (in the case where  $R_1=R_2$ )

$$\frac{1}{o} + \frac{1}{i} = \frac{1}{f}$$

where  $o$  = object distance from lens (+ve)

$i$  = image distance from lens (+ve in direction of light travel)

$f$  = focal length of lens (+ve in direction of light travel)

- ◆ Human eye employs a biconvex lens, and hence the image produced in the retina is inverted. The brain interprets the image correctly.

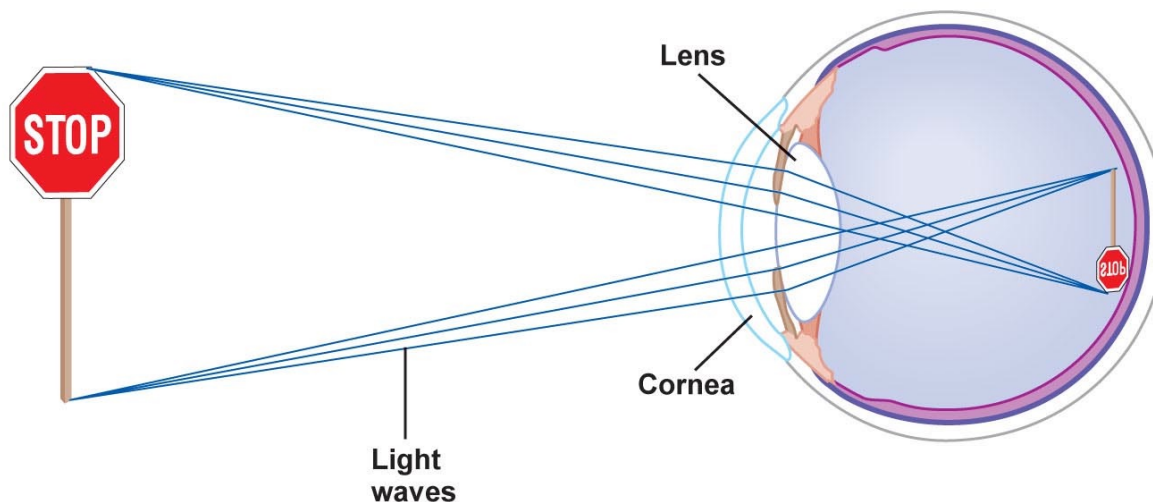

# Basic Optics

---

- ◆ If the thickness of the lens is much smaller than the radii of curvature at its two surfaces ( $d \ll R_1, R_2$ ), we can use the **thin lens formula** (in the case where  $R_1=R_2$ )

$$\frac{1}{o} + \frac{1}{i} = \frac{1}{f}$$

where  $o$  = object distance from lens (+ve)

$i$  = image distance from lens (+ve in direction of light travel)

$f$  = focal length of lens (+ve in direction of light travel)

- ◆ As the distance of the object from the lens increases, at what point does the image tend towards?

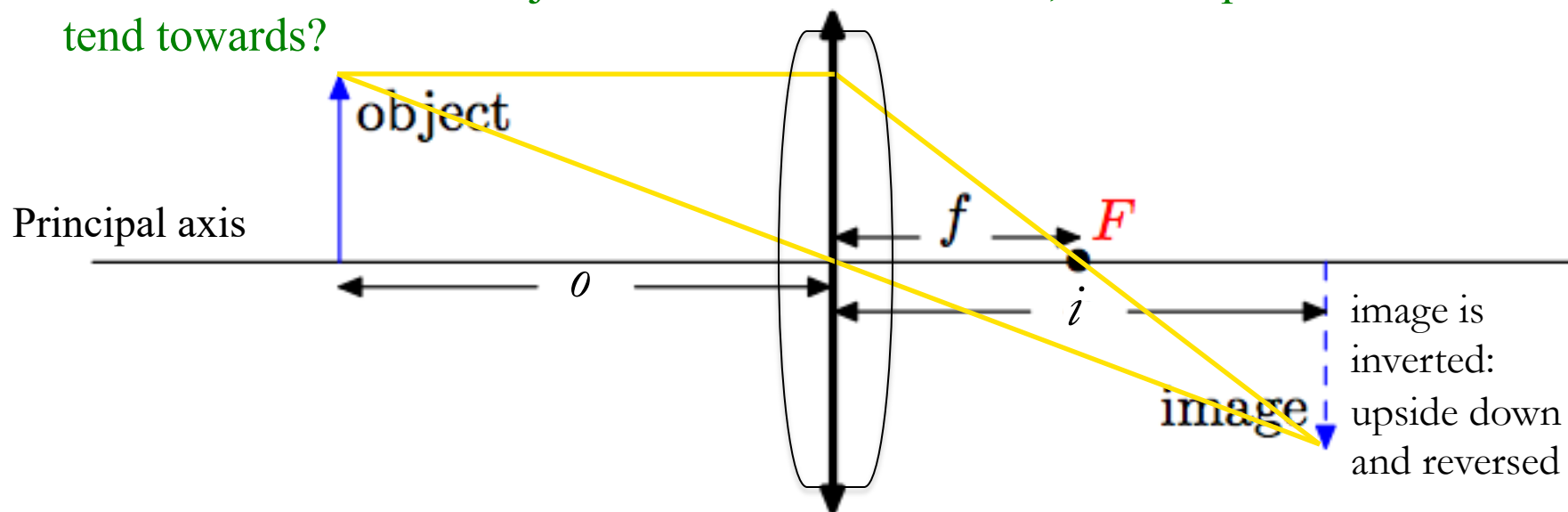

# Basic Optics

---

- ◆ If the thickness of the lens is much smaller than the radii of curvature at its two surfaces ( $d \ll R_1, R_2$ ), we can use the **thin lens formula** (in the case where  $R_1=R_2$ )

$$\frac{1}{o} + \frac{1}{i} = \frac{1}{f}$$

where  $o$  = object distance from lens (+ve)

$i$  = image distance from lens (+ve in direction of light travel)

$f$  = focal length of lens (+ve in direction of light travel)

- ◆ As the distance of the object from the lens increases, at what point does the image tend towards?  $F$

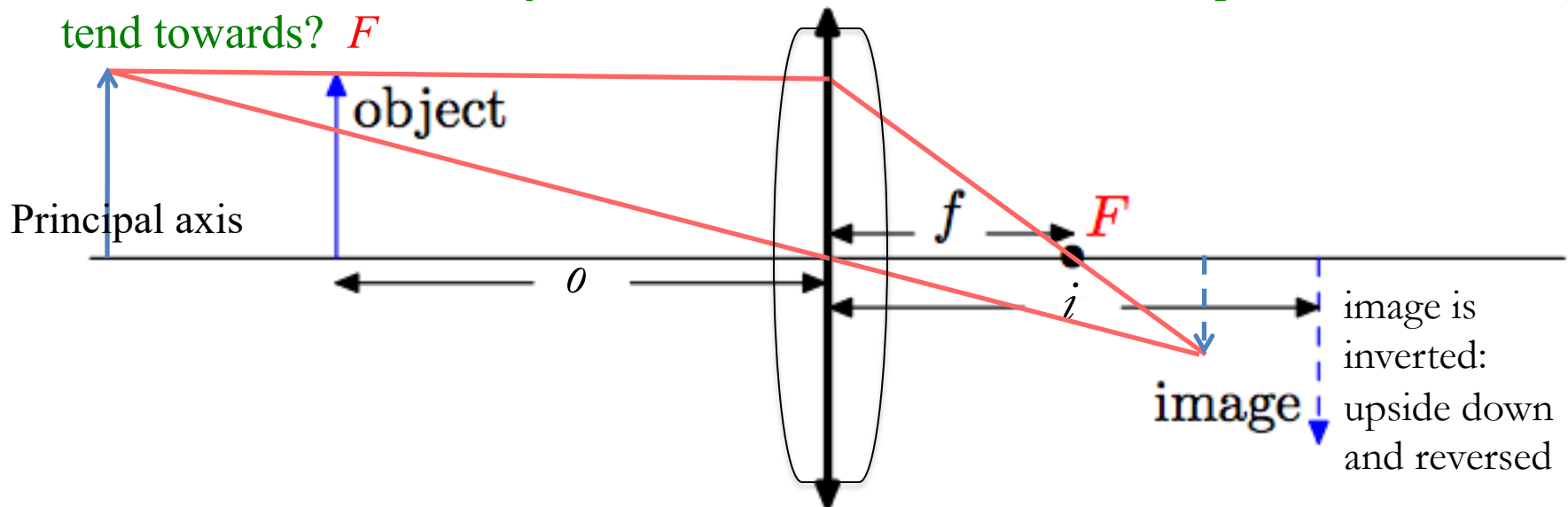

# Basic Optics

---

- ◆ If the thickness of the lens is much smaller than the radii of curvature at its two surfaces ( $d \ll R_1, R_2$ ), we can use the **thin lens formula** (in the case where  $R_1=R_2$ )

$$\frac{1}{o} + \frac{1}{i} = \frac{1}{f}$$

where  $o$  = object distance from lens (+ve)

$i$  = image distance from lens (+ve in direction of light travel)

$f$  = focal length of lens (+ve in direction of light travel)

- ◆ For an image to form at  $F$ , where would the object have to be located?

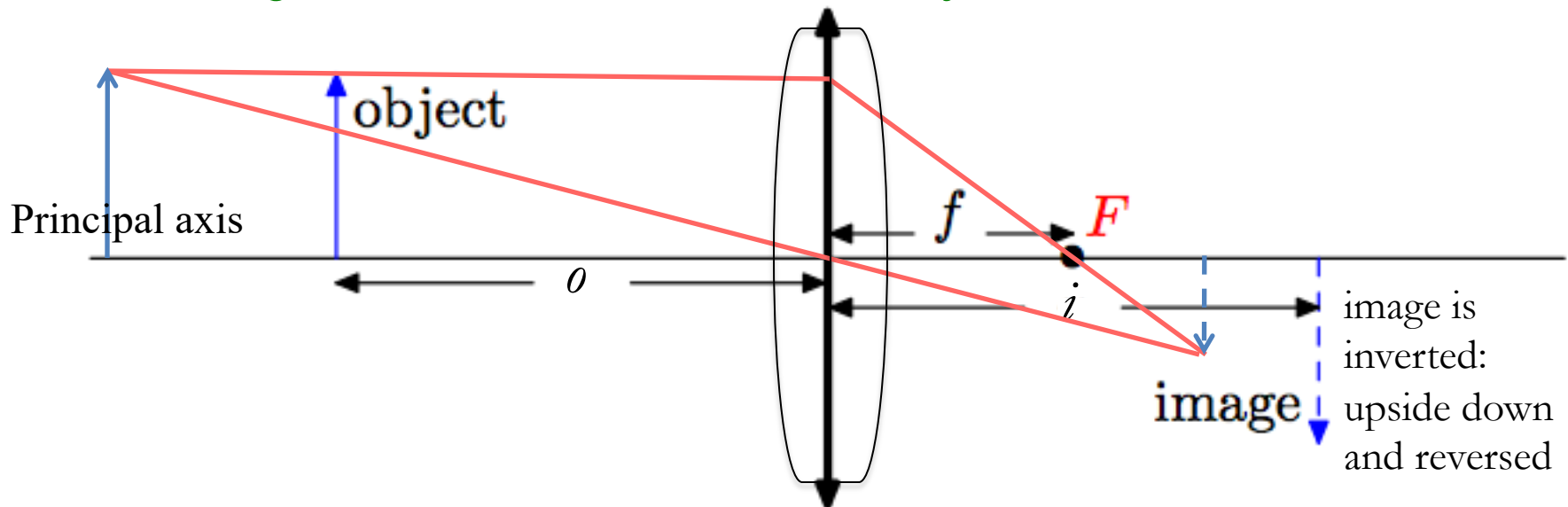



# Basic Optics

---

- ◆ If the thickness of the lens is much smaller than the radii of curvature at its two surfaces ( $d \ll R_1, R_2$ ), we can use the **thin lens formula** (in the case where  $R_1=R_2$ )

$$\frac{1}{o} + \frac{1}{i} = \frac{1}{f}$$

where  $o$  = object distance from lens (+ve)

$i$  = image distance from lens (+ve in direction of light travel)

$f$  = focal length of lens (+ve in direction of light travel)

- ◆ For an image to form at  $F$ , where would the object have to be located? **At infinity**

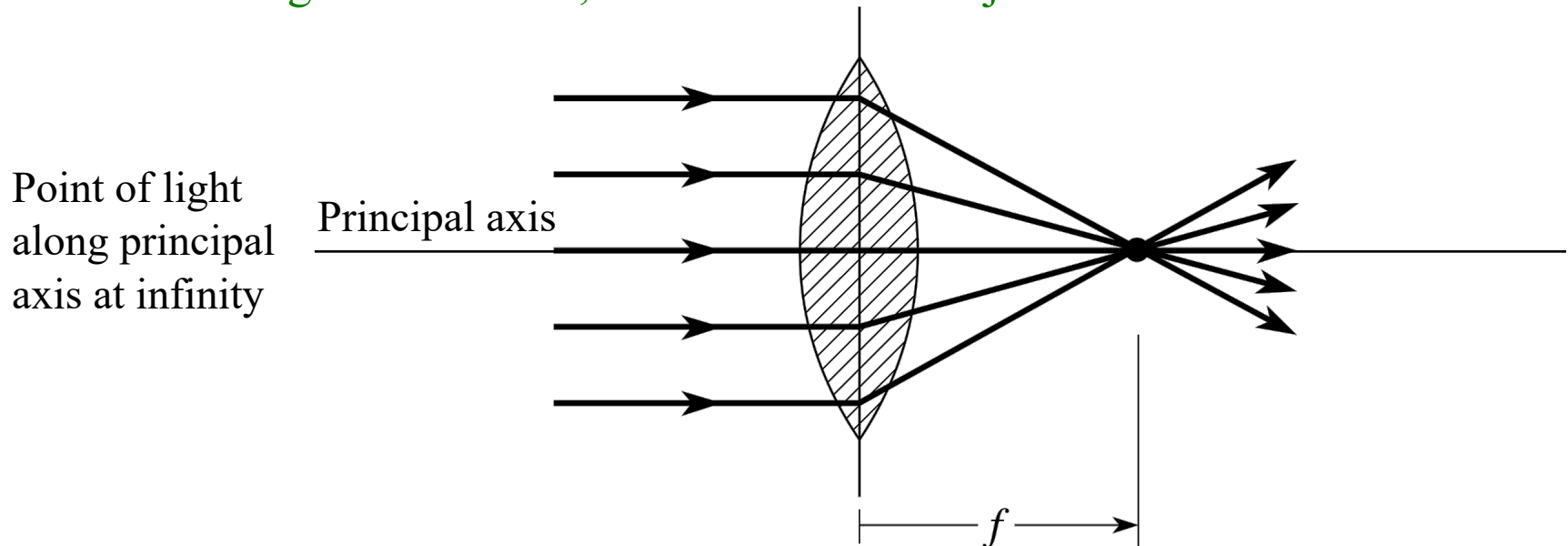

# Basic Optics

---

- ◆ Focusing of parallel light rays by a biconvex lens.

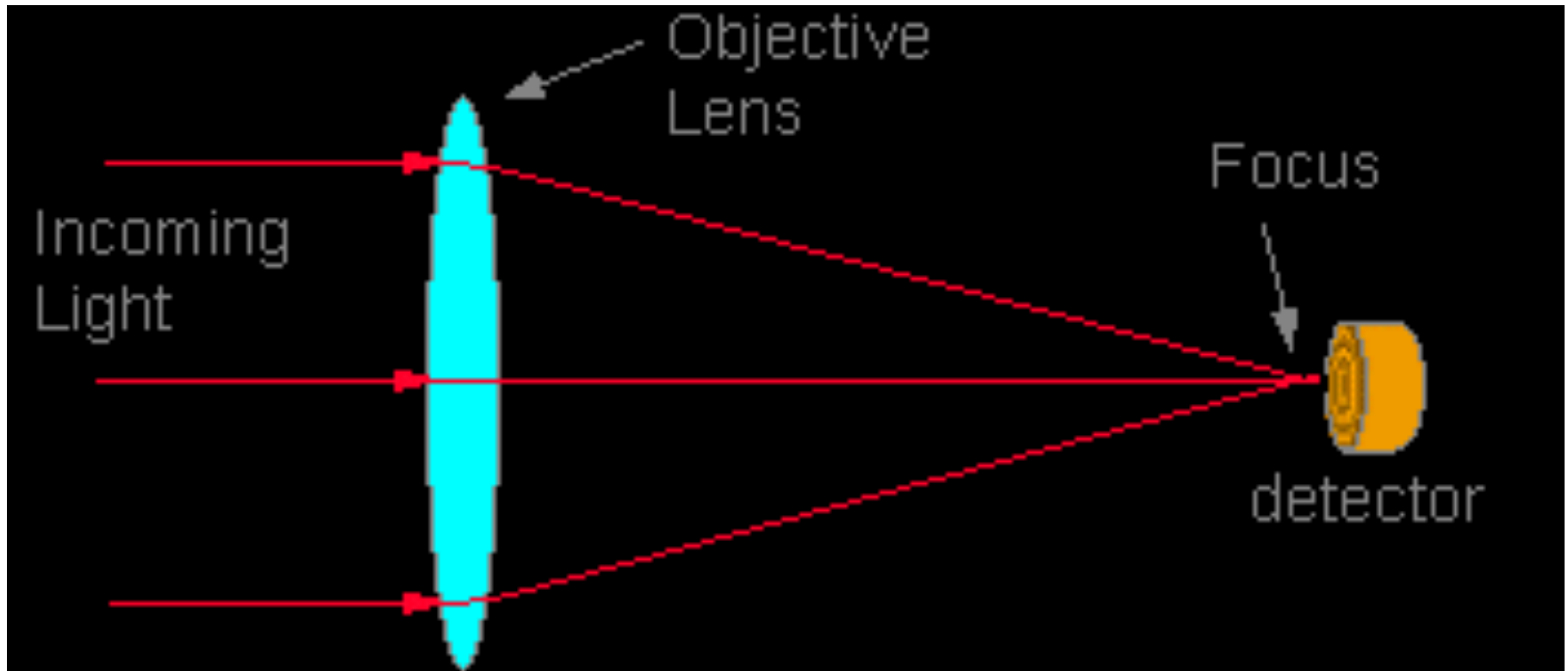

# Basic Optics

---

- ◆ Focusing of planar light wavefronts by a biconvex lens.

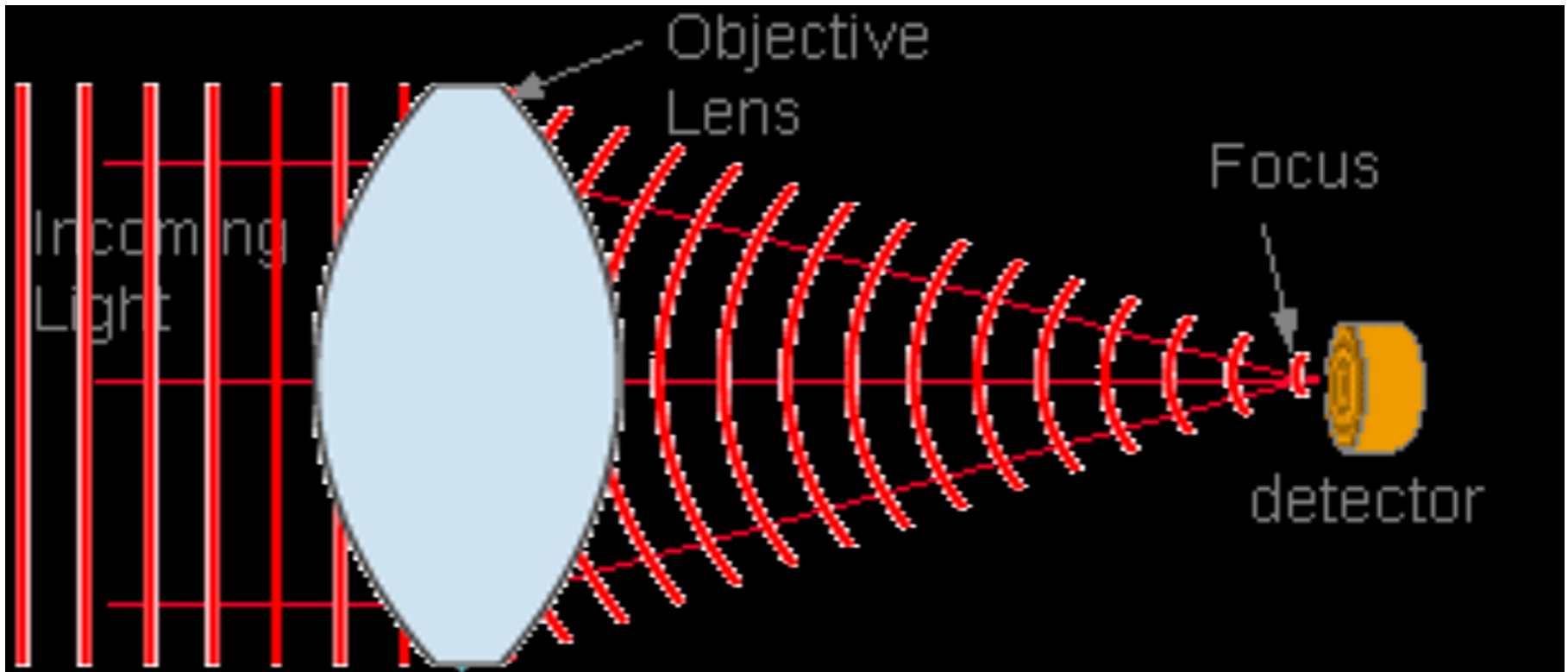

# Basic Optics

---

- ◆ For a 2-D object at infinity, an image is formed at the focal plane (to a good approximation).

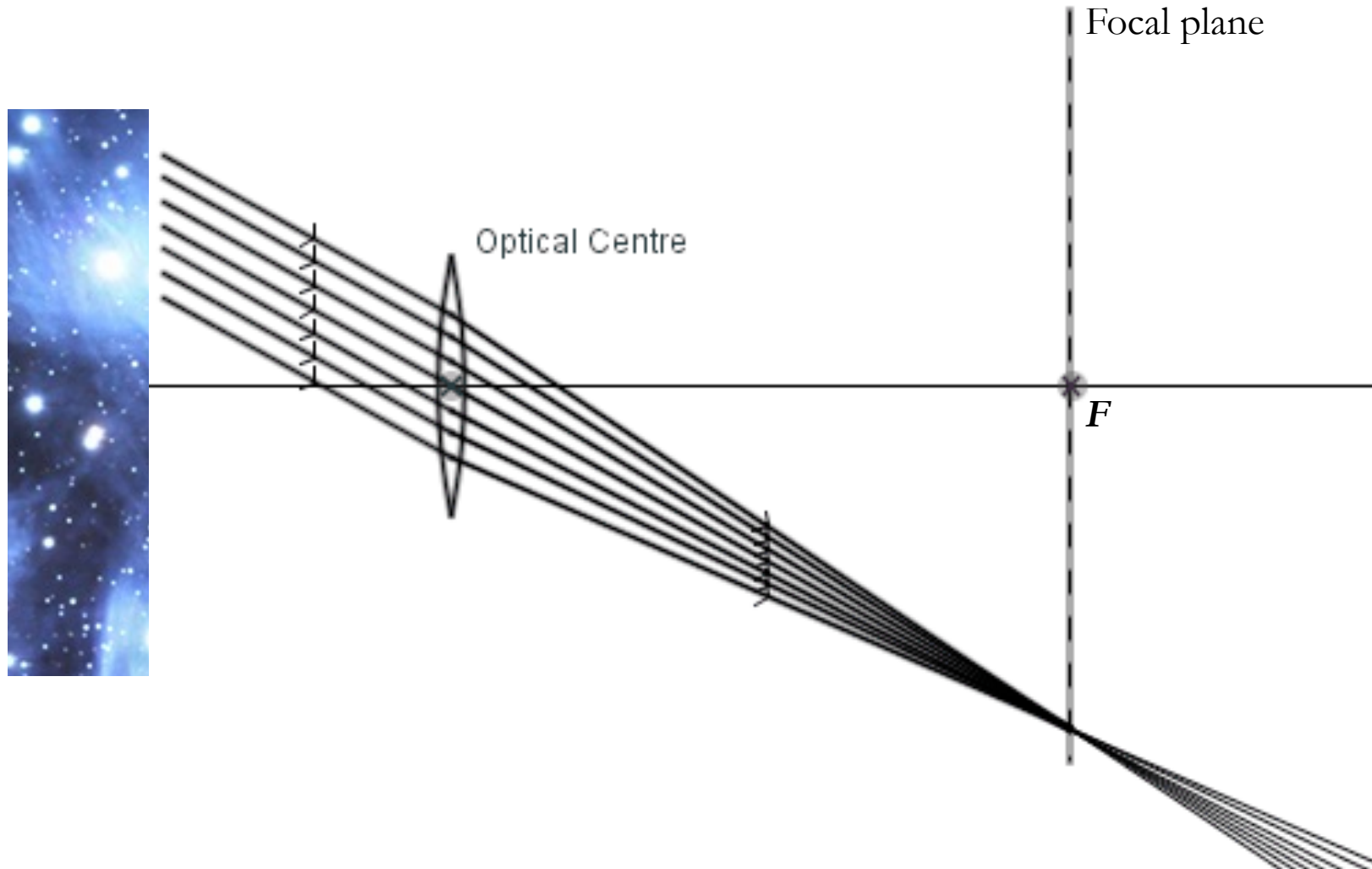

# Telescope Photography

---

- ◆ For photography in amateur telescopes or in professional telescopes, usually the eyepiece is removed and a detector (e.g., CCD) placed at the focal plane.

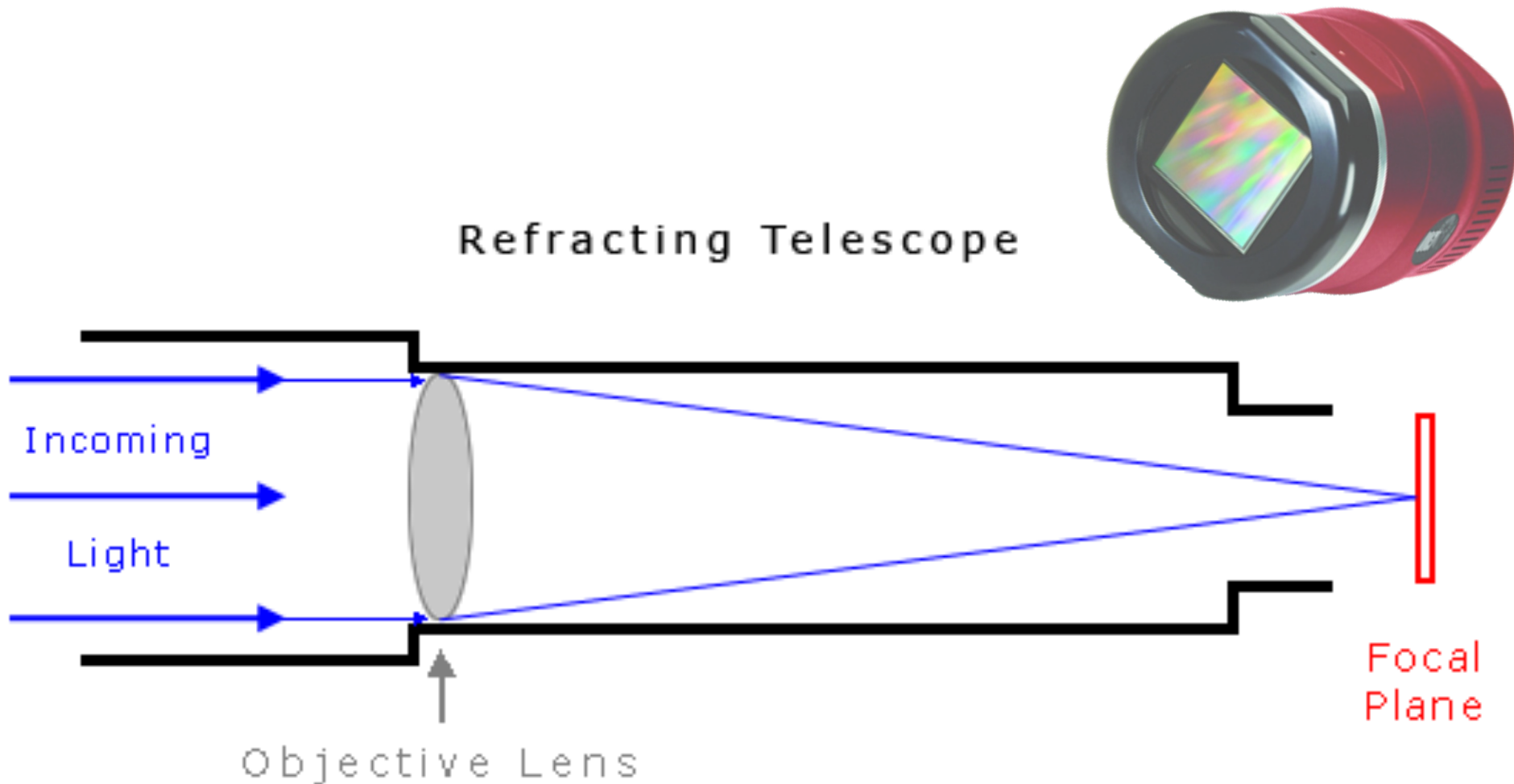

# Telescope Photography

---

- ◆ For photography in amateur telescopes or in professional telescopes, usually the eyepiece is removed and a detector (e.g., CCD) placed at the focal plane.
- ◆ Is this always possible?

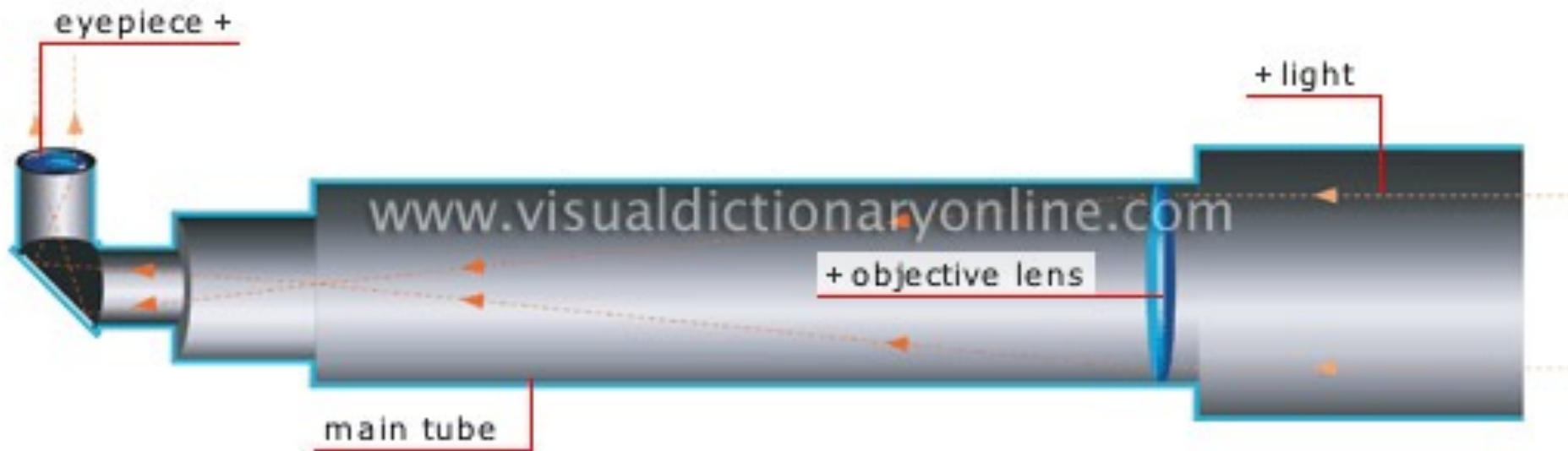

# Telescope Photography

---

- ◆ For photography in amateur telescopes or in professional telescopes, usually the eyepiece is removed and a detector (e.g., CCD) placed at the focal plane.
- ◆ Is this always possible? No, so beware of this before buying a telescope for astrophotography.

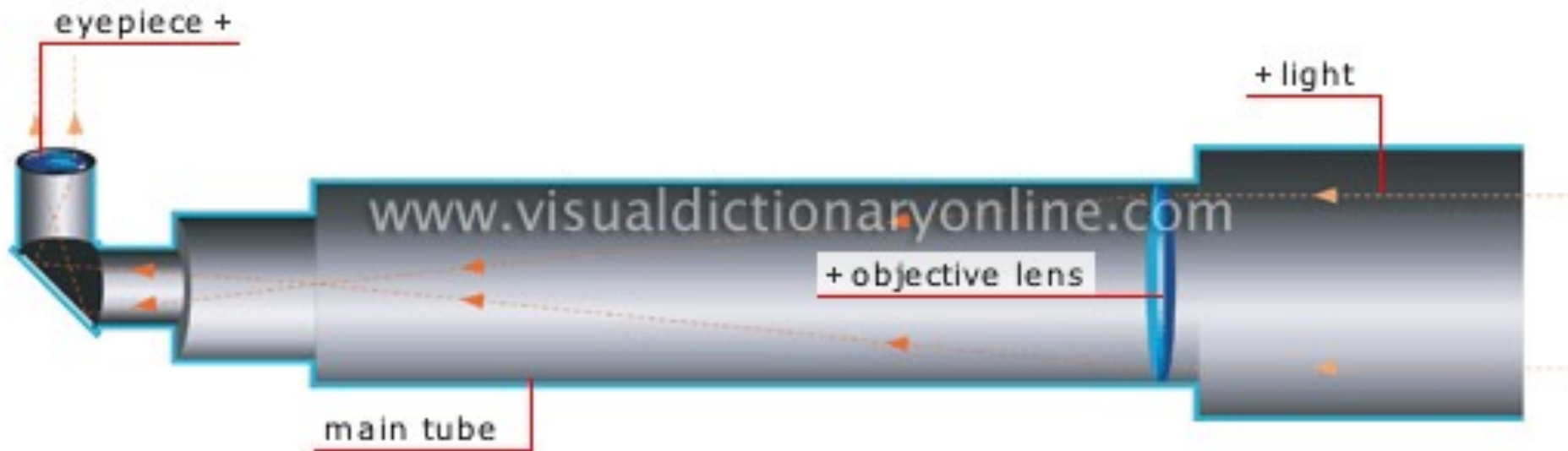

# Telescope Viewing

- ◆ For viewing, an eyepiece is used to refract light from the objective lens back into parallel rays (planar wavefronts) from a given direction.
- ◆ The eyepiece should be placed at the location where its focal point coincides with that of the objective lens (or mirror). **Why?**

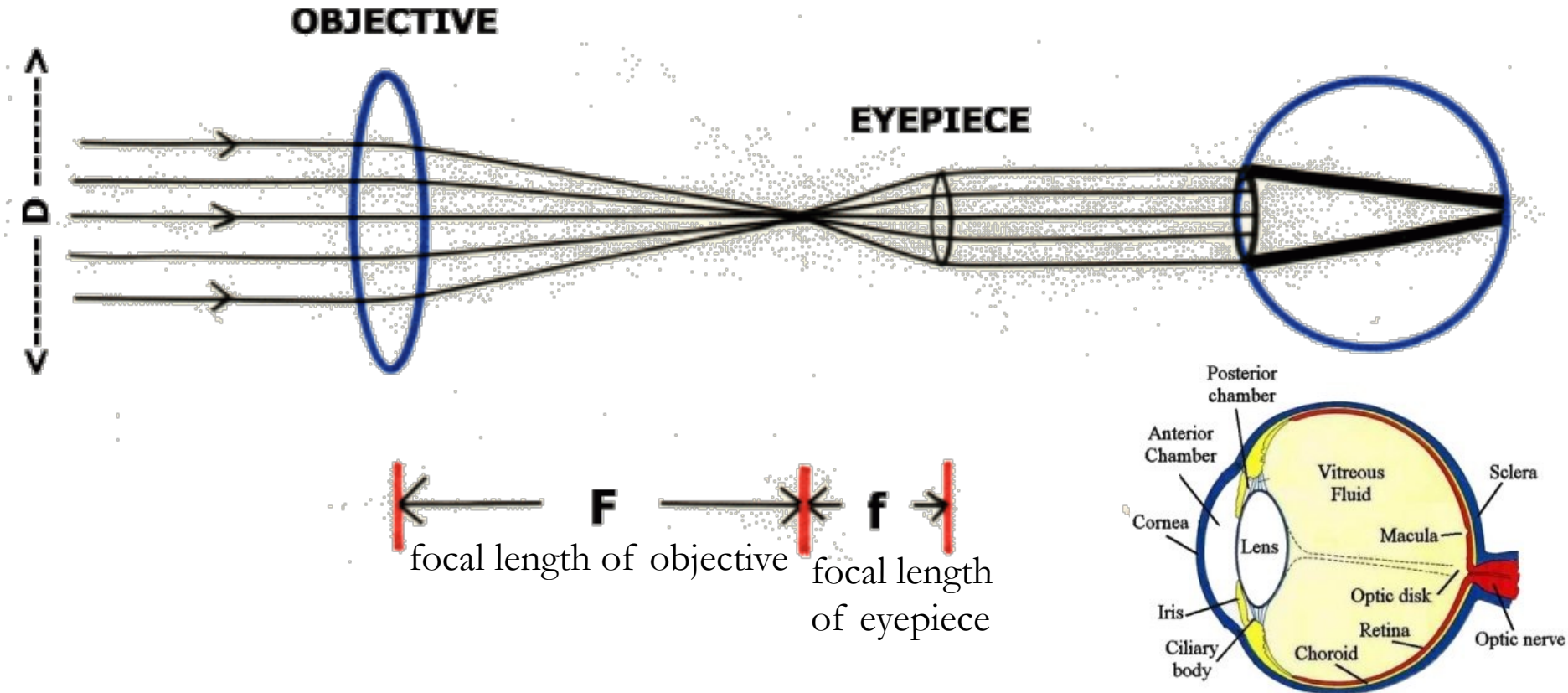



# Telescope Viewing

- ◆ For viewing, an eyepiece is used to refract light from the objective lens back into parallel rays (planar wavefronts) from a given direction.
- ◆ The eyepiece should be placed at the location where its focal point coincides with that of the objective lens (or mirror). Why?

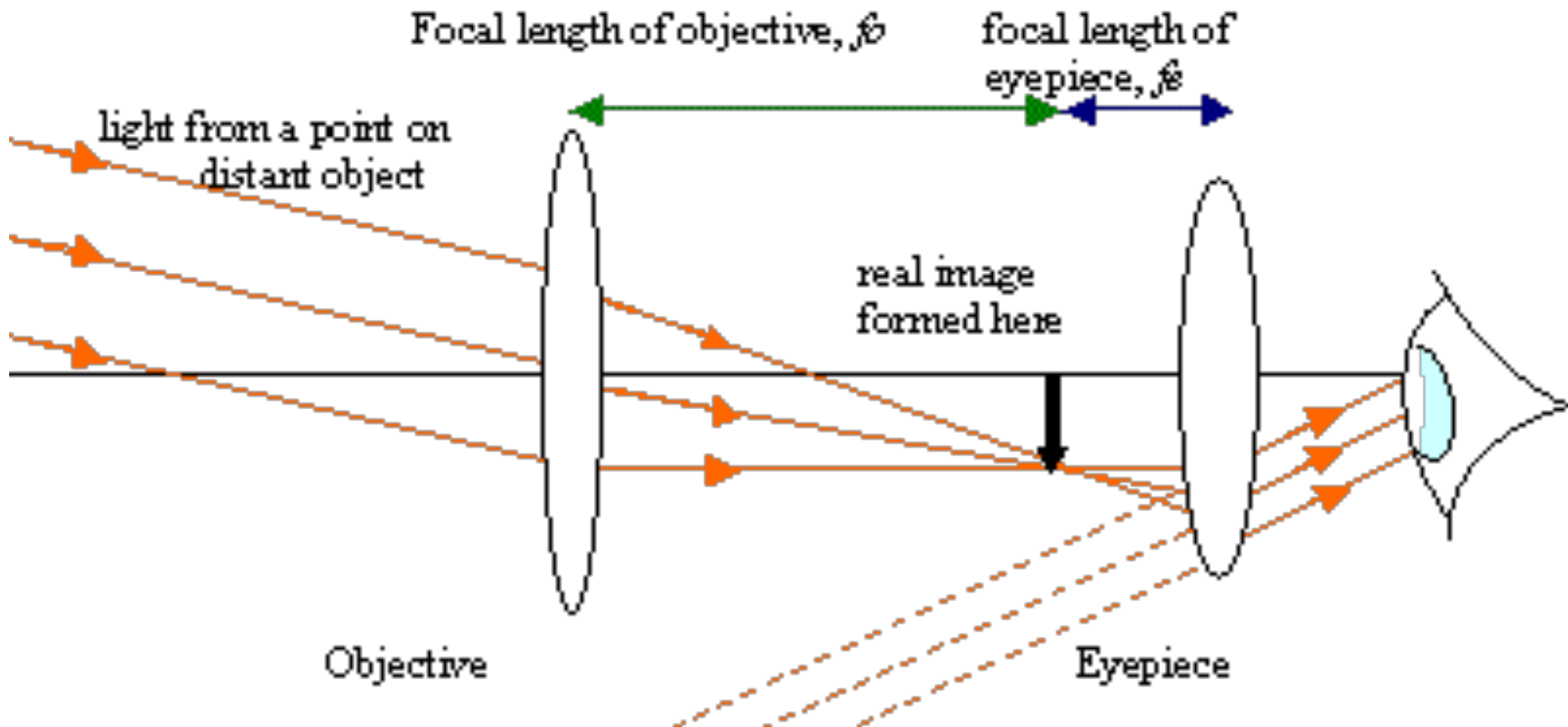

# Telescope Viewing

- ◆ For viewing, an eyepiece is used to refract light from the objective lens back into parallel rays (planar wavefronts) from a given direction.
- ◆ The eyepiece should be placed at the location where its focal point coincides with that of the objective lens (or mirror). **Why? So as to recollimate the light into parallel rays.**

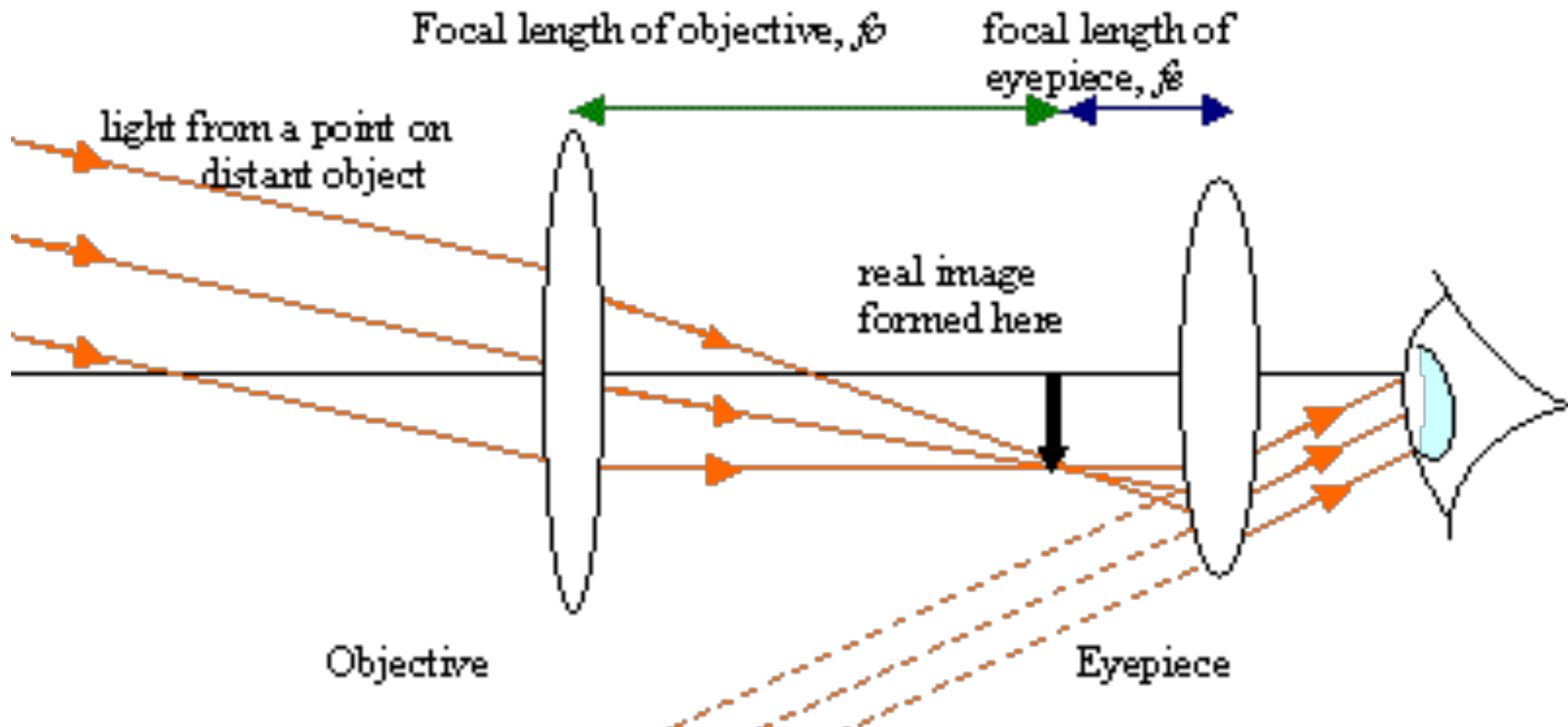

# Basic Optics

---

- ◆ If the thickness of the lens is much smaller than the radii of curvature at its two surfaces ( $d \ll R_1, R_2$ ), we can use the **thin lens formula** (in the case where  $R_1=R_2$ )

$$\frac{1}{o} + \frac{1}{i} = \frac{1}{f}$$

where  $o$  = object distance from lens (+ve)

$i$  = image distance from lens (-ve against direction of light travel)

$f$  = focal length of lens (-ve against direction of light travel)

- ◆ Light rays emerges from lens following same principles as biconvex lens.

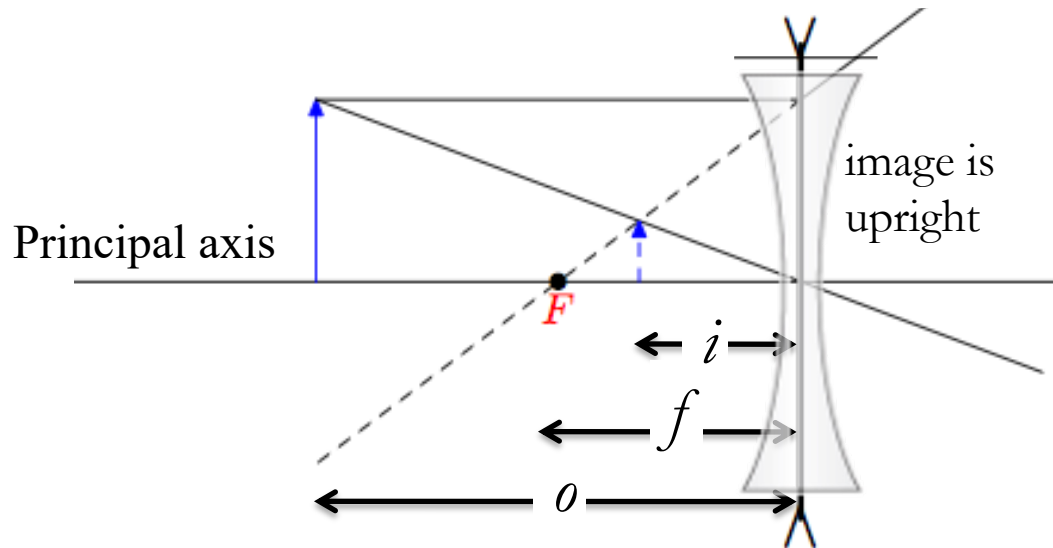

# Basic Optics

---

- ◆ If the thickness of the lens is much smaller than the radii of curvature at its two surfaces ( $d \ll R_1, R_2$ ), we can use the **thin lens formula** (in the case where  $R_1=R_2$ )

$$\frac{1}{o} + \frac{1}{i} = \frac{1}{f}$$

where  $o$  = object distance from lens (+ve)

$i$  = image distance from lens (-ve against direction of light travel)

$f$  = focal length of lens (-ve against direction of light travel)

- ◆ A ray parallel to the principal axis emerges from the lens such that it projects backwards through the focus.

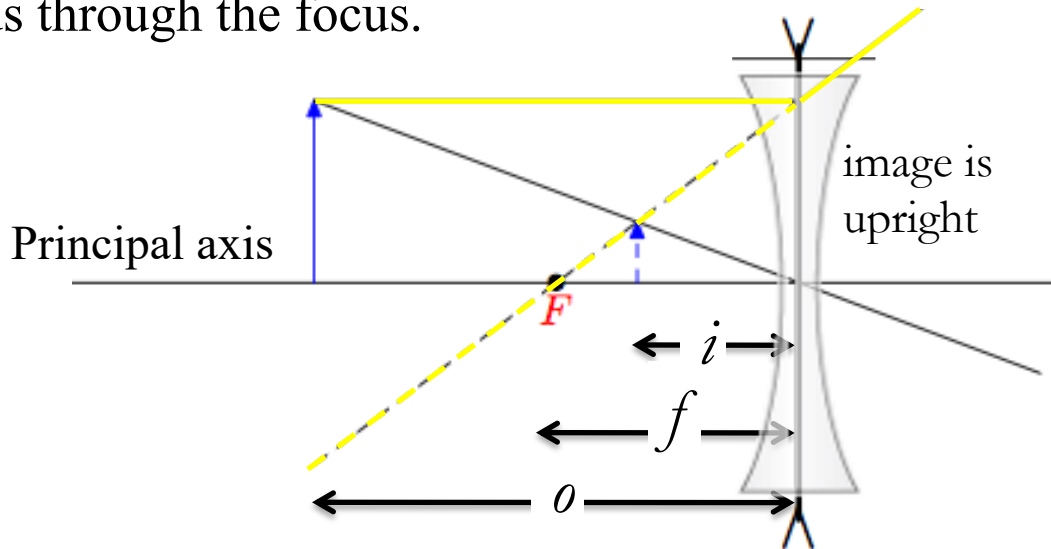

# Basic Optics

---

- ◆ If the thickness of the lens is much smaller than the radii of curvature at its two surfaces ( $d \ll R_1, R_2$ ), we can use the **thin lens formula** (in the case where  $R_1=R_2$ )

$$\frac{1}{o} + \frac{1}{i} = \frac{1}{f}$$

where  $o$  = object distance from lens (+ve)

$i$  = image distance from lens (-ve against direction of light travel)

$f$  = focal length of lens (-ve against direction of light travel)

- ◆ A ray passing through the center of the lens emerges undeviated. An image forms at the intersection of the virtual and real rays.

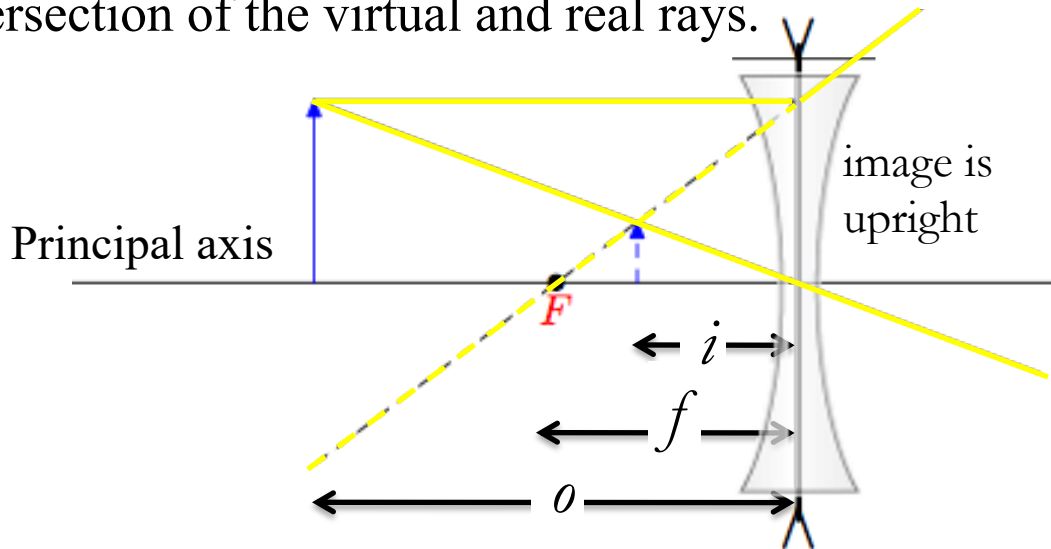

# Basic Optics

- ◆ If the thickness of the lens is much smaller than the radii of curvature at its two surfaces ( $d \ll R_1, R_2$ ), we can use the **thin lens formula** (in the case where  $R_1=R_2$ )

$$\frac{1}{o} + \frac{1}{i} = \frac{1}{f}$$

where  $o$  = object distance from lens (+ve)  
 $i$  = image distance from lens (-ve against direction of light)  
 $f$  = focal length of lens (-ve against direction of light)

- ◆ Because the image cannot be projected on a screen, it is a “virtual” image. In this case, the image is upright.

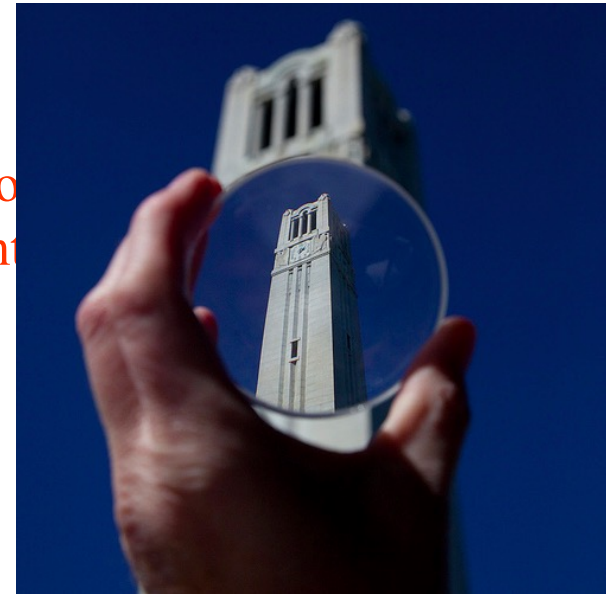
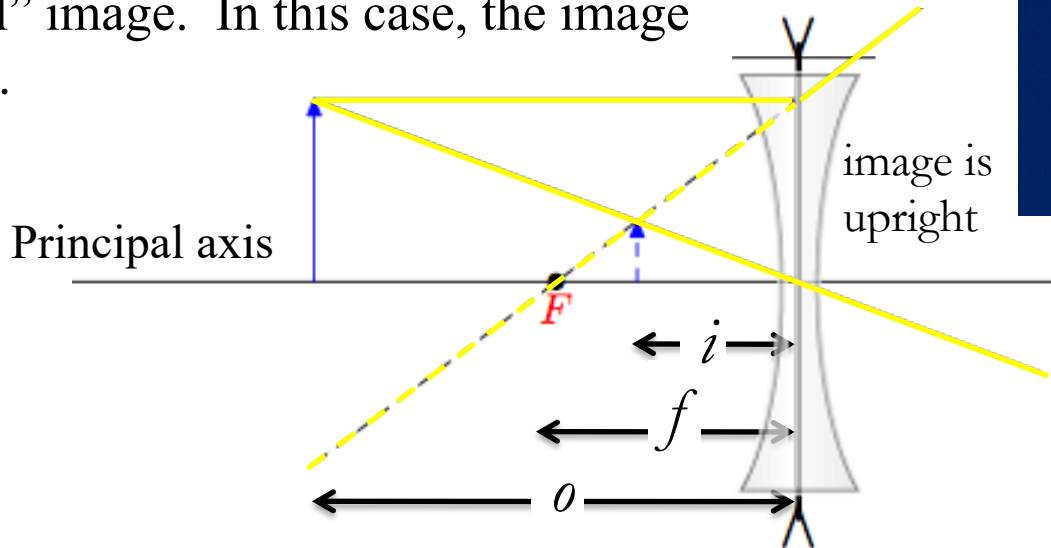

# Basic Optics

- ◆ The **mirror equation** (approximation; true only when mirror segment smaller than radius of curvature)

$$\frac{1}{o} + \frac{1}{i} = \frac{1}{f}$$

where  $o$  = object distance from mirror (+ve)

$i$  = image distance from mirror (+ve in direction of light travel)

$f$  = focal length of mirror (+ve in direction of light travel)

- ◆ A ray parallel to the principal axis reflects through the focus. A ray through the center of curvature reflects undeviated.

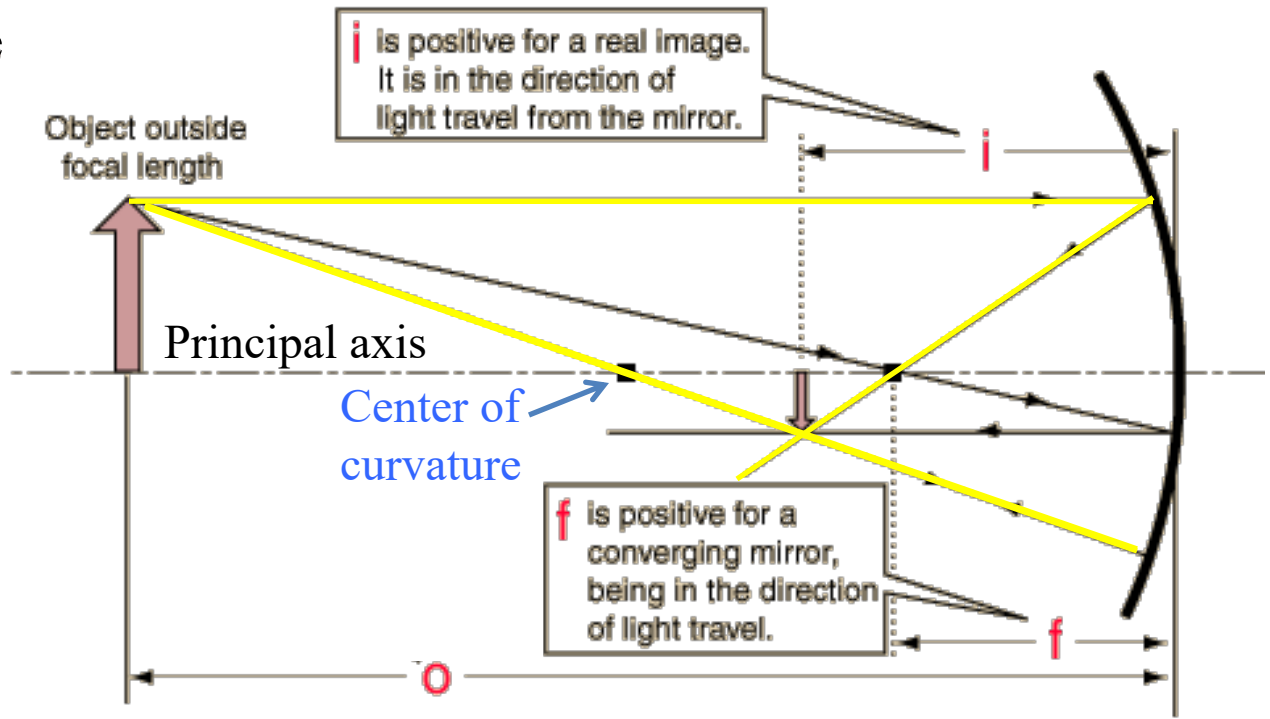

# Basic Optics

- ◆ The **mirror equation** (approximation; true only when mirror segment smaller than radius of curvature)

$$\frac{1}{o} + \frac{1}{i} = \frac{1}{f}$$

where  $o$  = object distance from mirror (+ve)

$i$  = image distance from mirror (+ve in direction of light travel)

$f$  = focal length of mirror (+ve in direction of light travel)

- ◆ An image forms where the two rays intersect.
- ◆ If the image can be projected on a screen, it is a “real” image. In this case, the image is inverted.

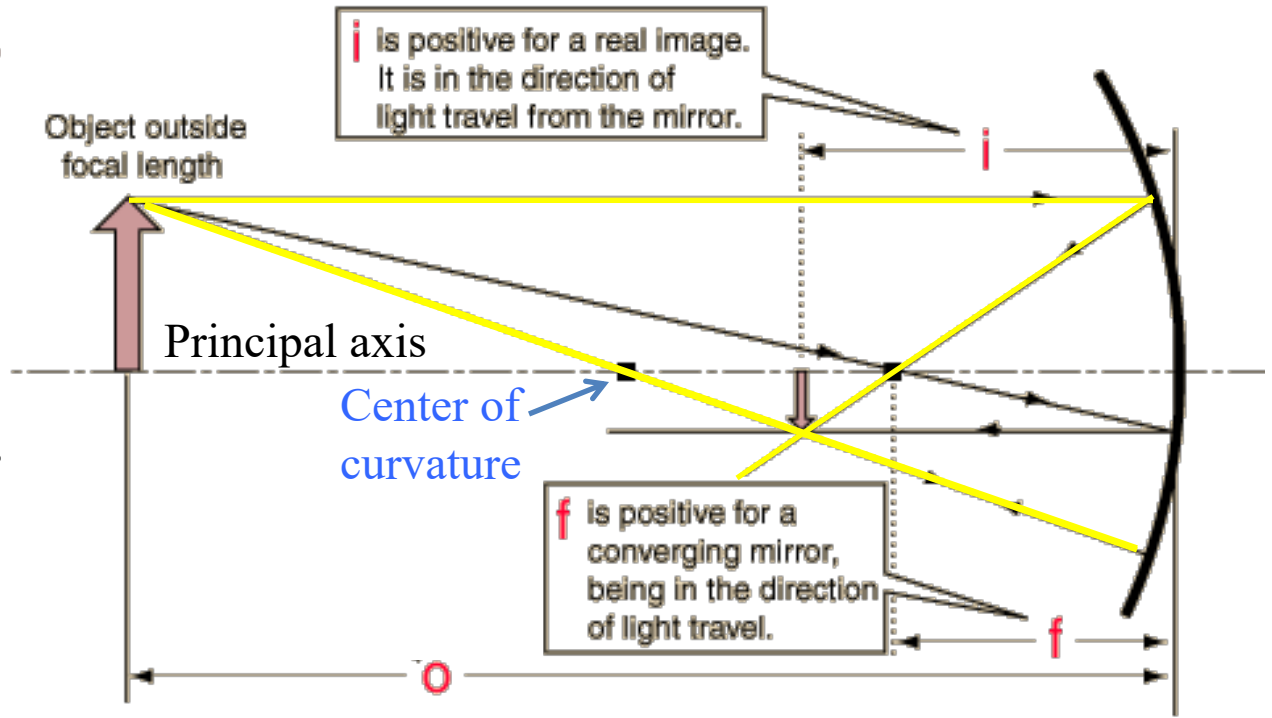



# Basic Optics

---

- ◆ For a 2-D object at infinity, an image is produced at the focal plane (to a good approximation).

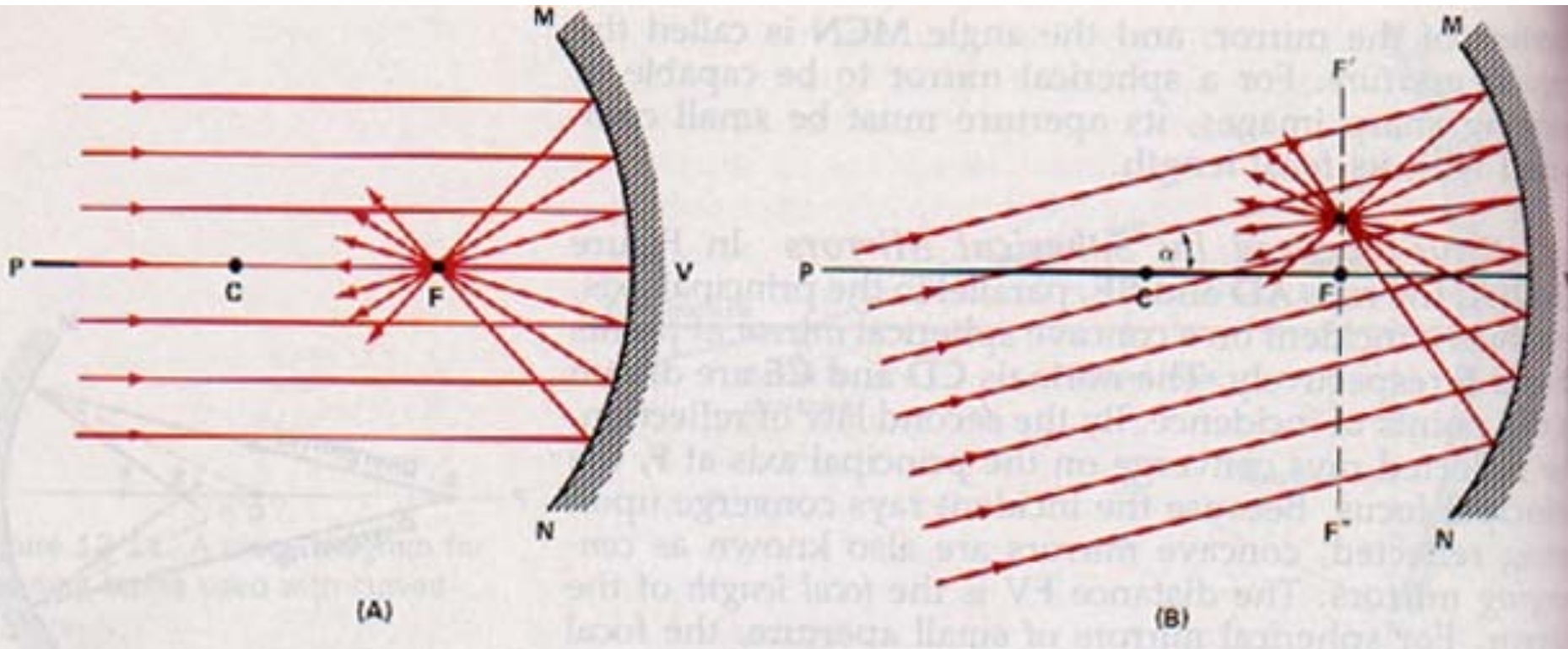

# Basic Optics

---

- ◆ Focusing of parallel light rays by a concave mirror.

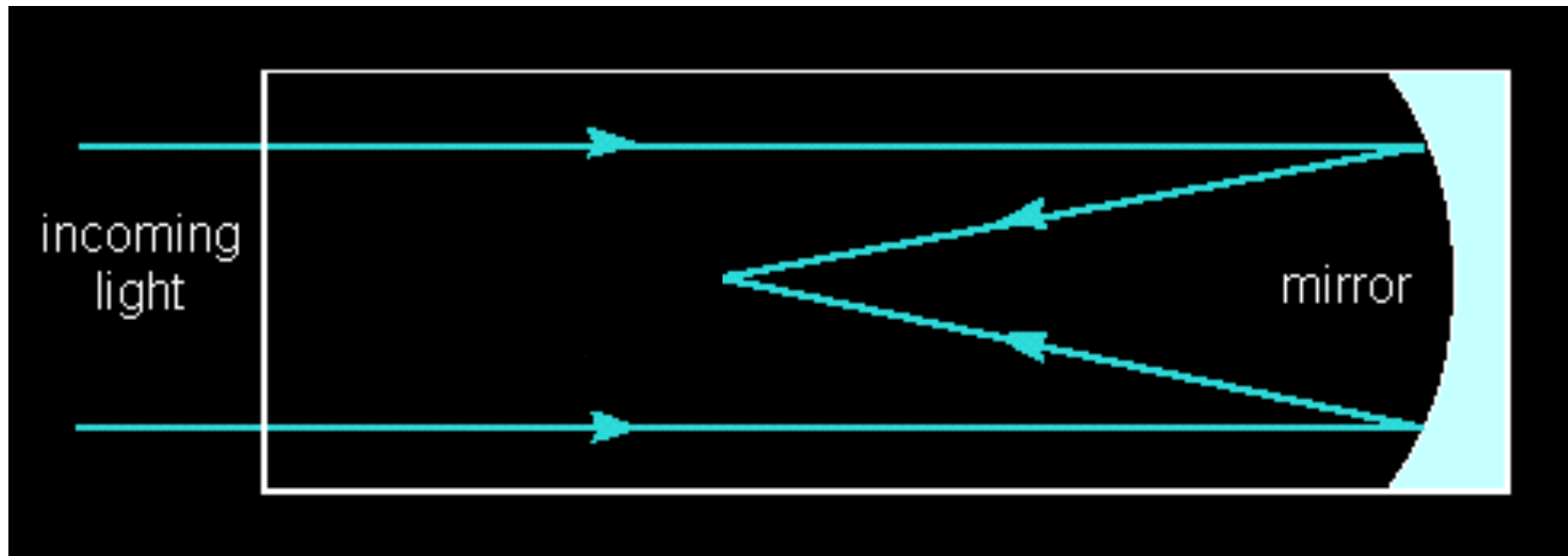

# Basic Optics

---

- ◆ Focusing of planar light wavefronts by a concave mirror.

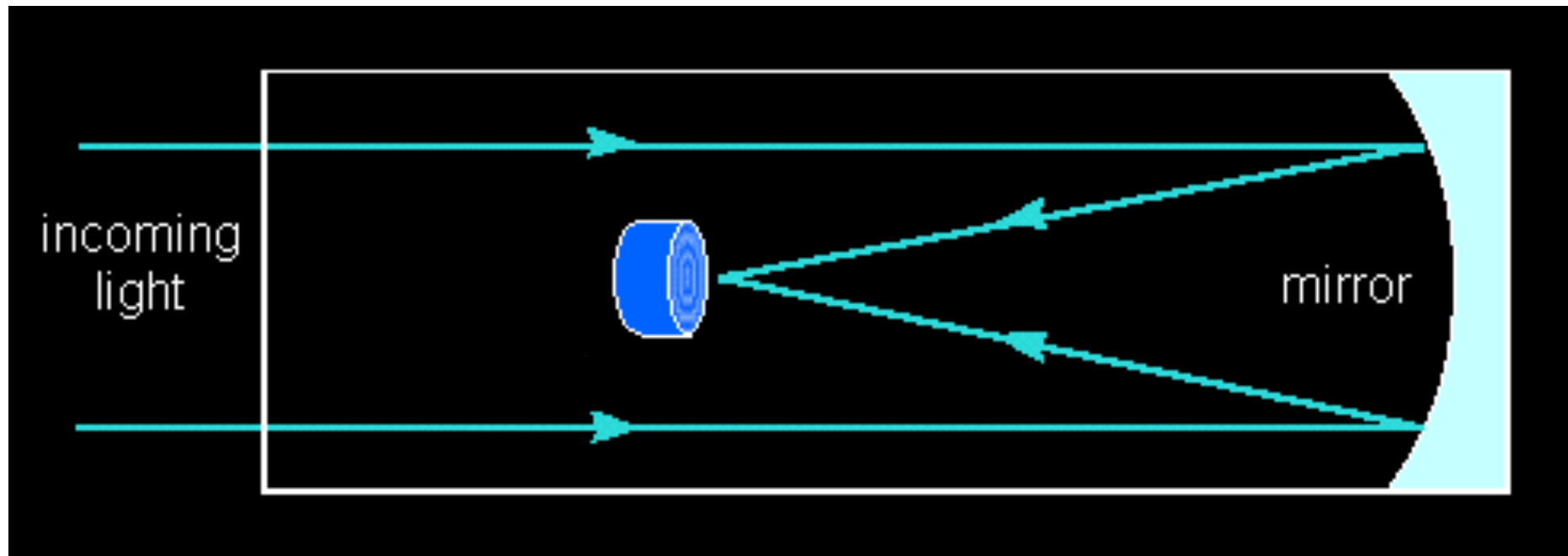

# Telescope Photography

---

- ◆ For photography in amateur telescopes or in professional telescopes, usually the eyepiece is removed and a detector (e.g., CCD) placed at the focal plane.

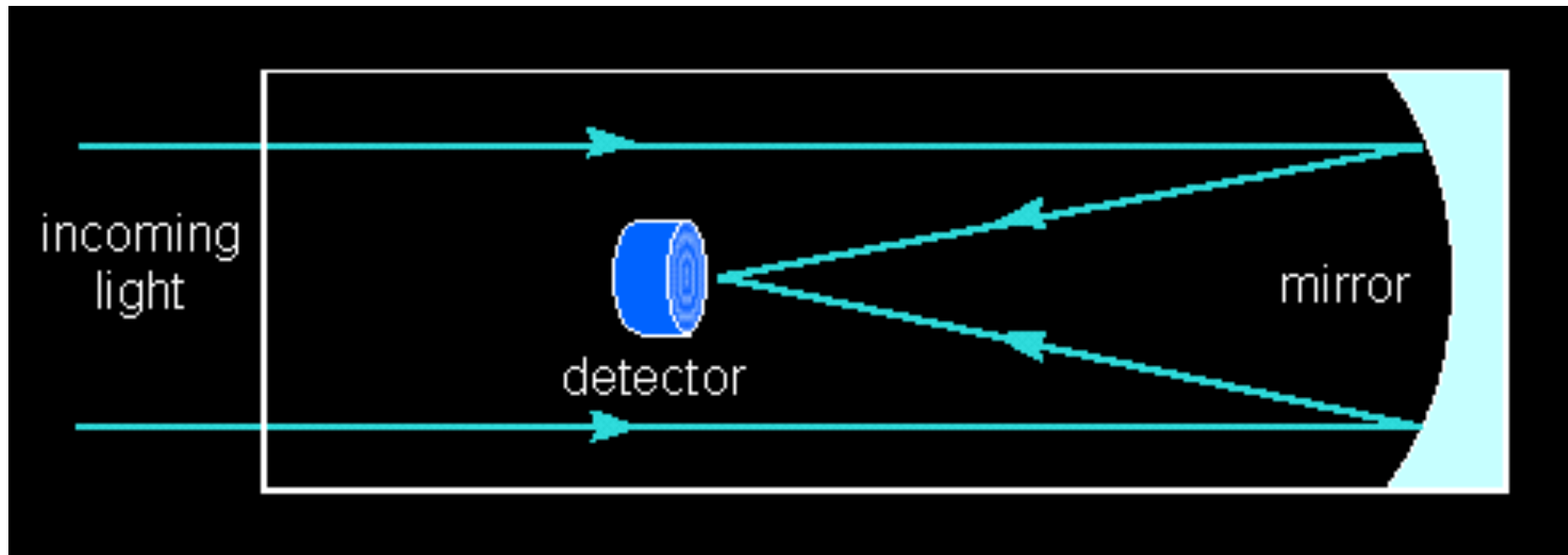

# Telescope Photography

---

- ◆ For photography in amateur telescopes or in professional telescopes, usually the eyepiece is removed and a detector (e.g., CCD) placed at the focal plane.

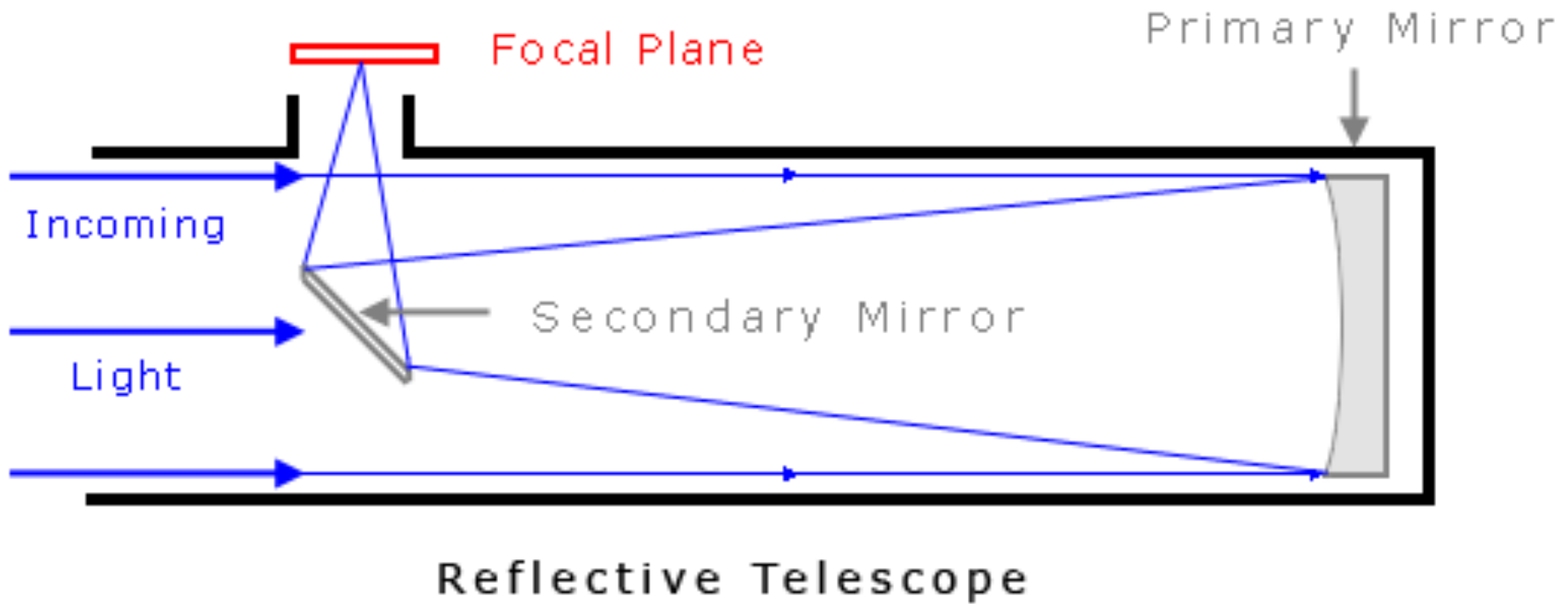

# Telescope Photography

---

- ◆ For photography in amateur telescopes or in professional telescopes, usually the eyepiece is removed and a detector (e.g., CCD) placed at the focal plane.

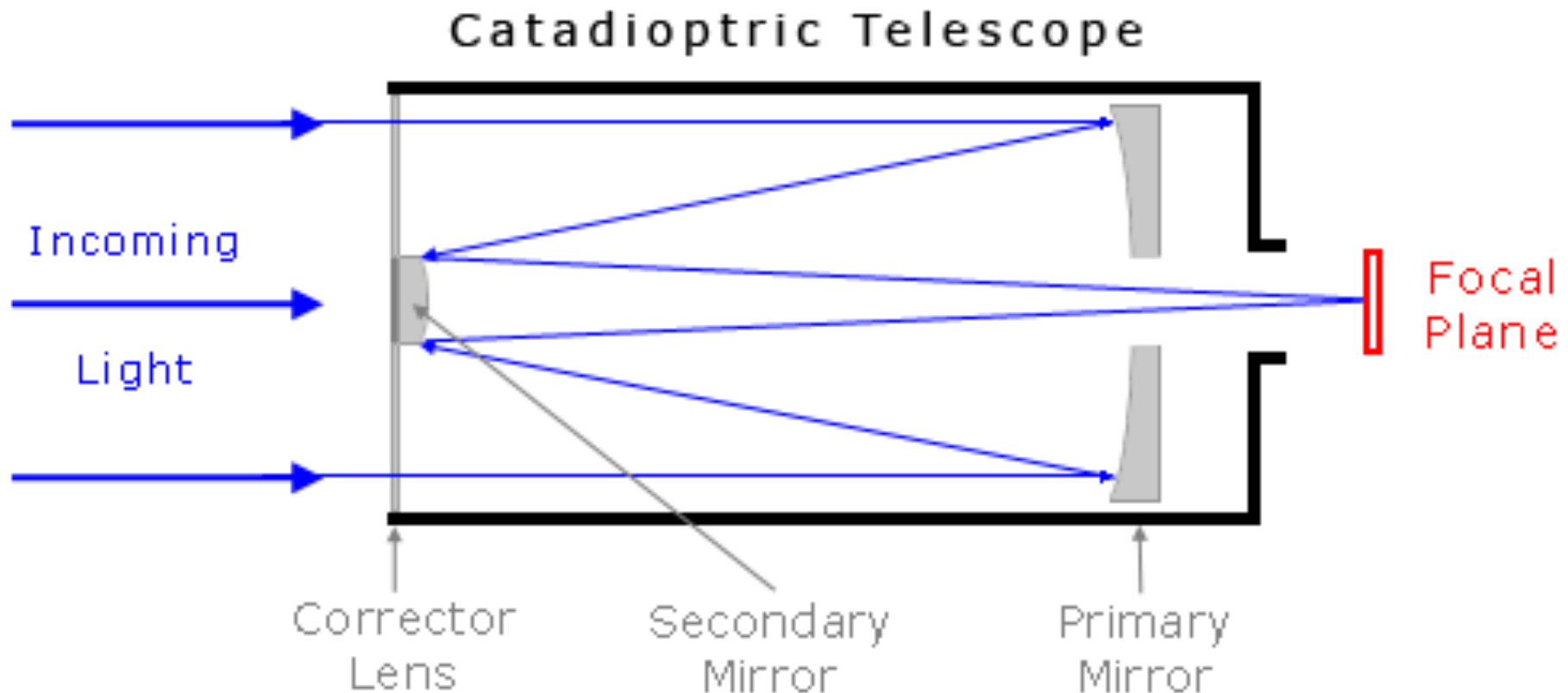

# Telescope Viewing

- ◆ To view an image, an eyepiece is used to refract light from the objective mirror back into parallel rays (planar wavefronts) from a given direction.
- ◆ The eyepiece should be placed at the location where its focal point coincides with that of the objective mirror.

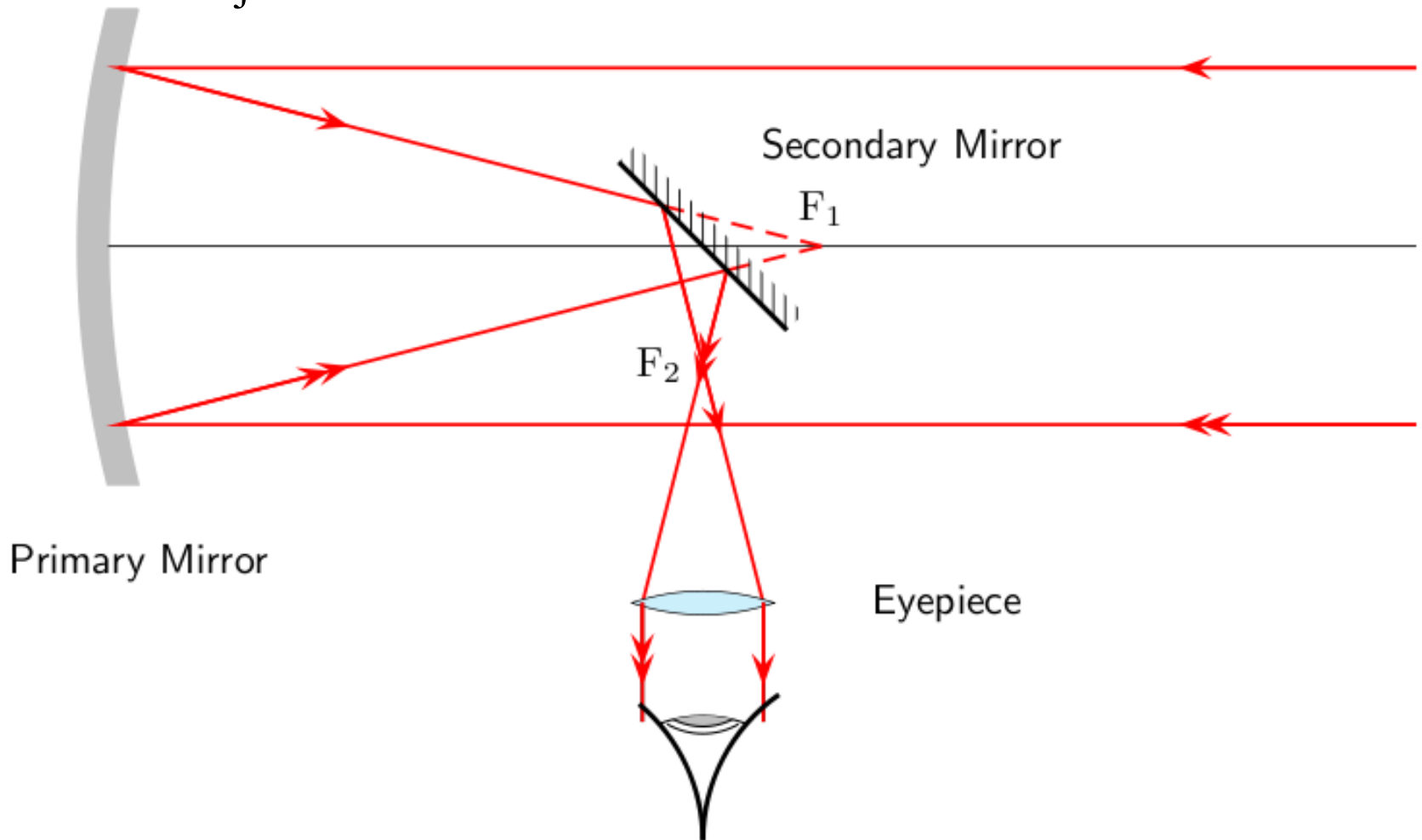

# Basic Optics

- ◆ The **mirror equation** (approximation; true only when mirror segment smaller than radius of curvature)

$$\frac{1}{o} + \frac{1}{i} = \frac{1}{f}$$

where  $o$  = object distance from mirror (+ve)

$i$  = image distance from mirror (-ve in direction opposite to light travel)

$f$  = focal length of mirror (-ve in direction opposite to light travel)

- ◆ Convex mirror produces a virtual and upright image.

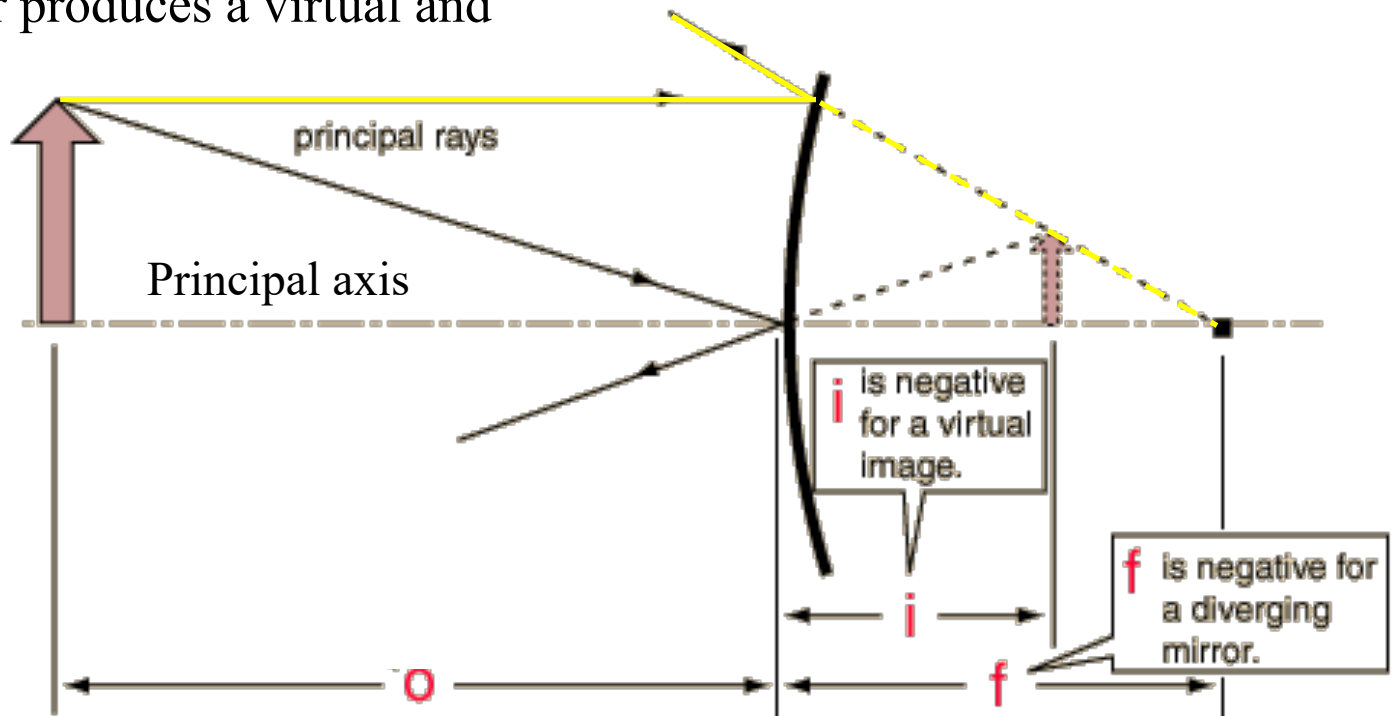



# Basic Optics

- ◆ The **mirror equation** (approximation; true only when mirror segment smaller than radius of curvature)

$$\frac{1}{o} + \frac{1}{i} = \frac{1}{f}$$

where  $o$  = object distance from mirror (+ve)

$i$  = image distance from mirror (-ve in direction opposite to light travel)

$f$  = focal length of mirror (-ve in direction opposite to light travel)

- ◆ Convex mirror produces a virtual and upright image.

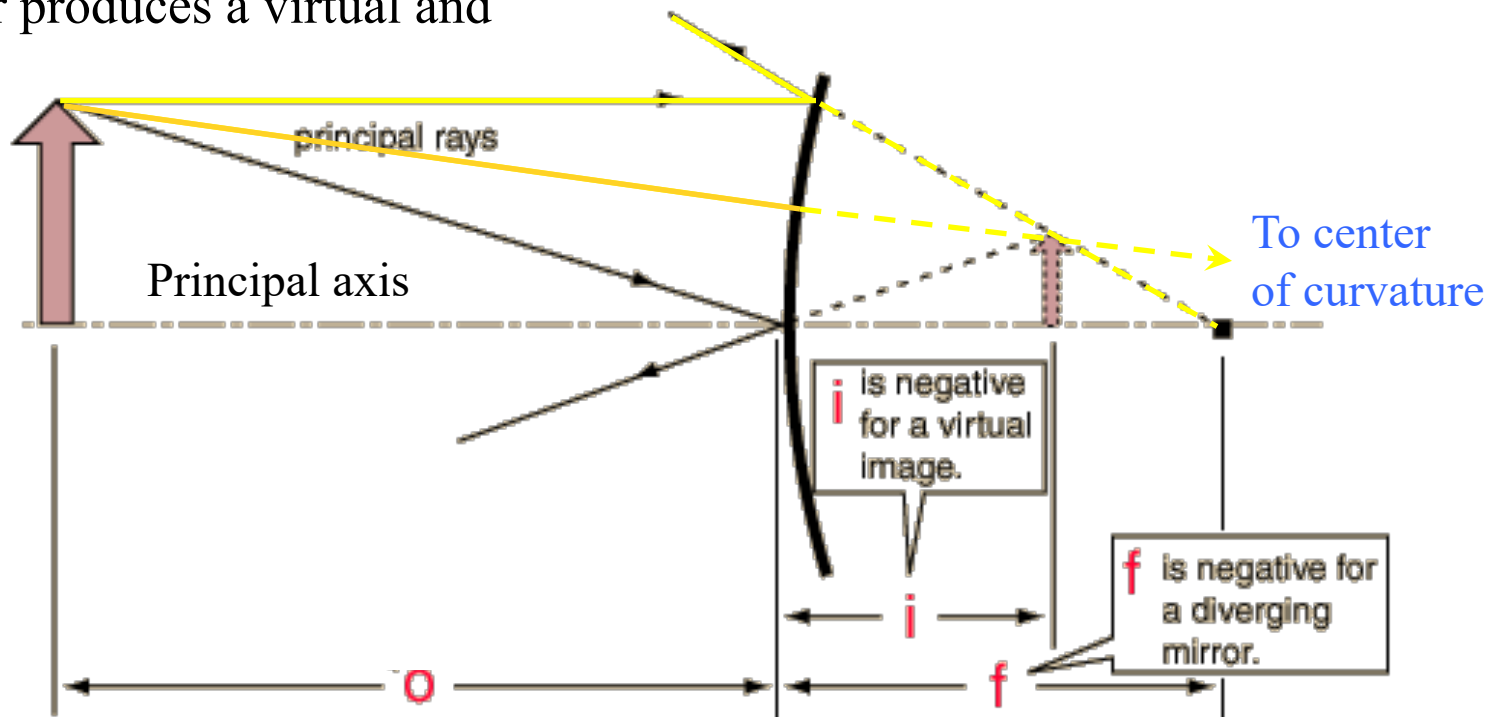

# Basic Optics

---

- ◆ Are these mirrors convex or concave?



# Basic Optics

---

◆ Are these mirrors convex or concave?

Concave



Convex



# Basic Optics

---

- ◆ Linear magnification (linear dimensions of image relative to object) of a lens or mirror is given by the formula

$$m = -\frac{i}{o}$$

where  $m < 0$  if the image is inverted

$m > 0$  if the image is upright

$|m| > 1$  if enlarged

- ◆ What is the magnification in the example below?

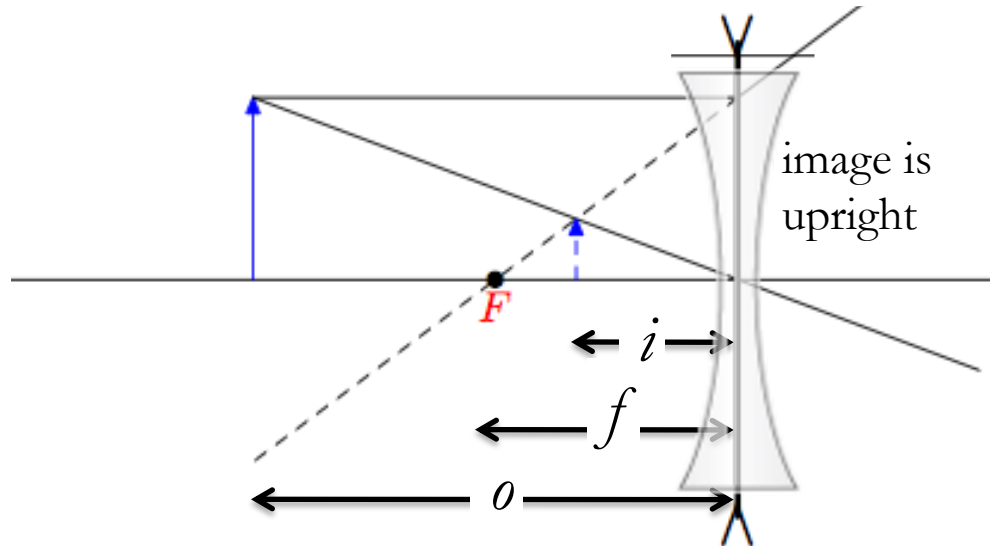
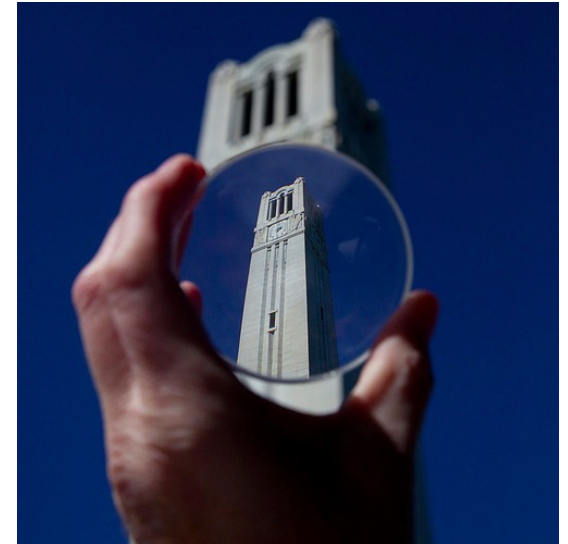

# Basic Optics

---

- ◆ Linear magnification (linear dimensions of image relative to object) of a lens or mirror is given by the formula

$$m = -\frac{i}{o}$$

where  $m < 0$  if the image is inverted

$m > 0$  if the image is upright

$|m| > 1$  if enlarged

- ◆ What is the magnification in the example below?

About 1/3

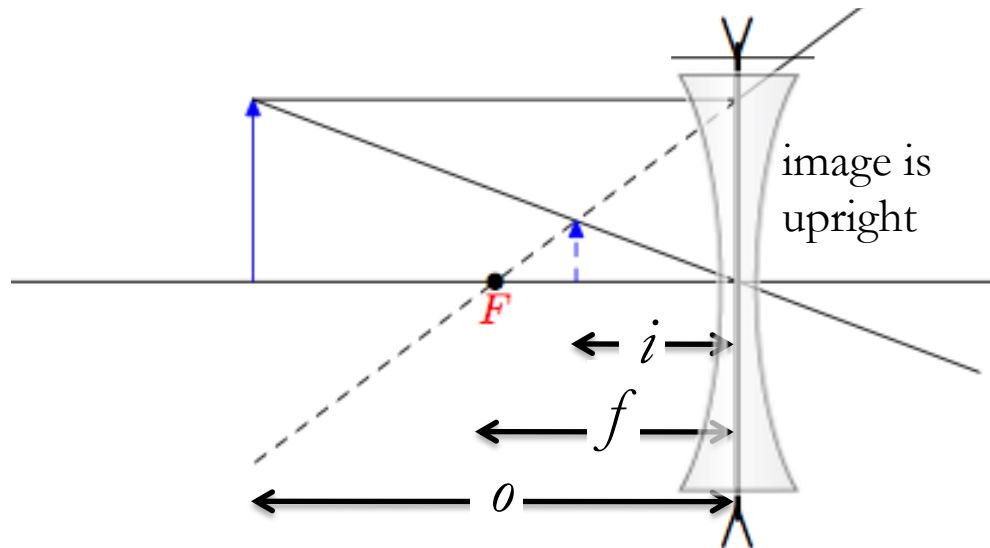
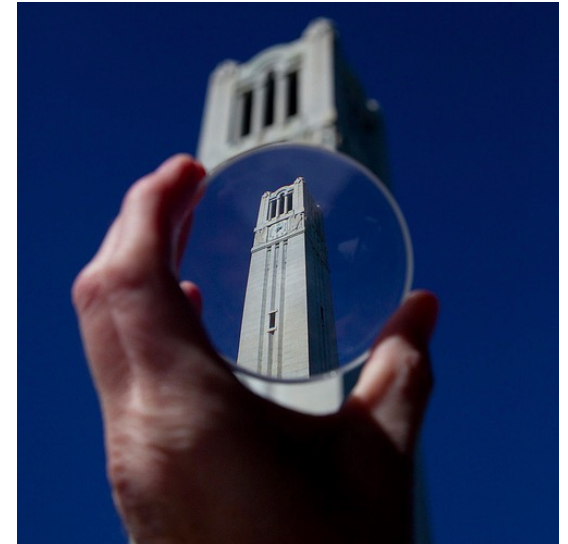

# Basic Optics

- ◆ Linear magnification (linear dimensions of image relative to object) of a lens or mirror is given by the formula

$$m = -\frac{i}{o}$$

where  $m < 0$  if the image is inverted

$m > 0$  if the image is upright

$|m| > 1$  if enlarged

- ◆ What is the magnification in the example below?

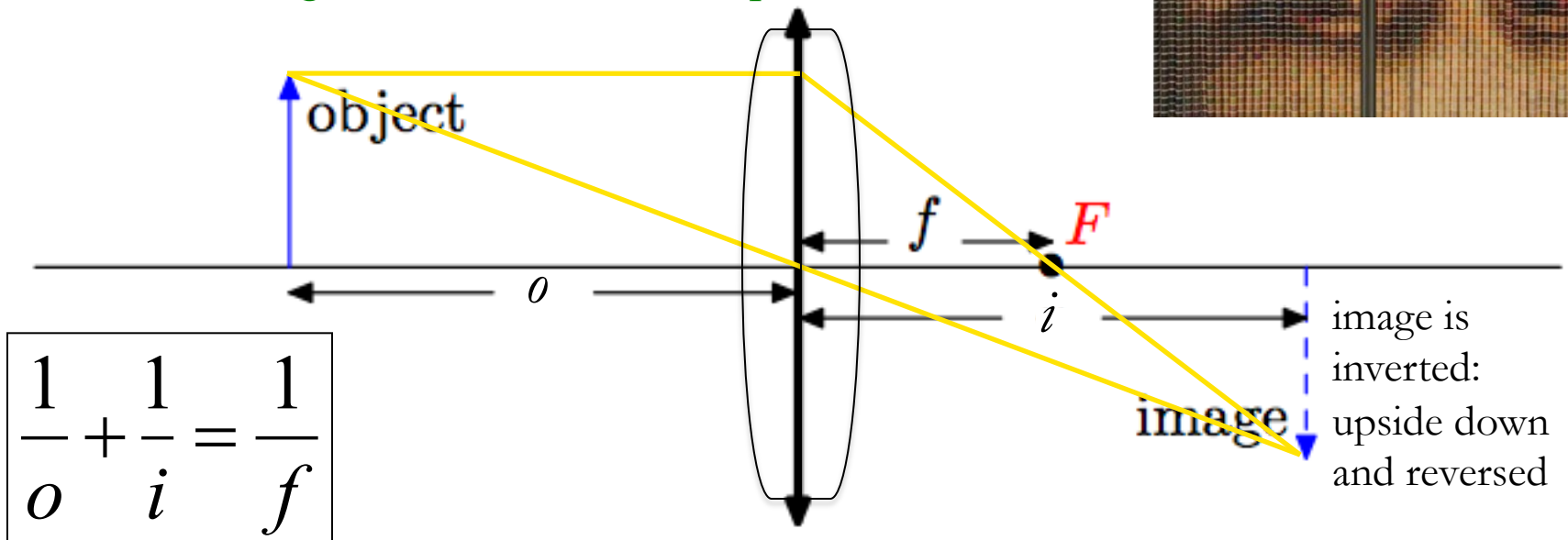

$$\frac{1}{o} + \frac{1}{i} = \frac{1}{f}$$

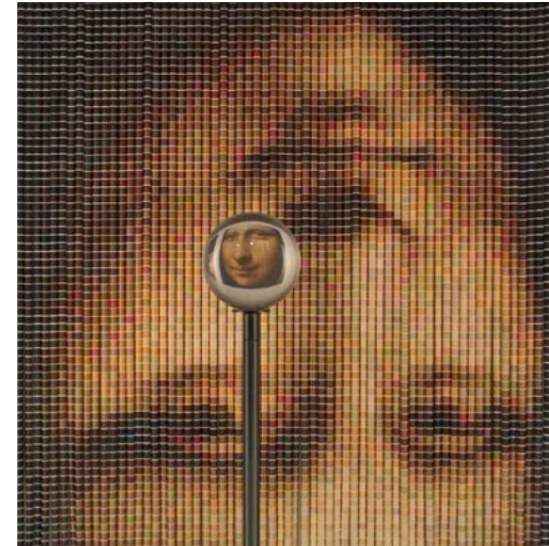

# Basic Optics

- ◆ Linear magnification (linear dimensions of image relative to object) of a lens or mirror is given by the formula

$$m = -\frac{i}{o}$$

where  $m < 0$  if the image is inverted  
 $m > 0$  if the image is upright  
 $|m| > 1$  if enlarged

- ◆ What is the magnification in the example below?

About -1

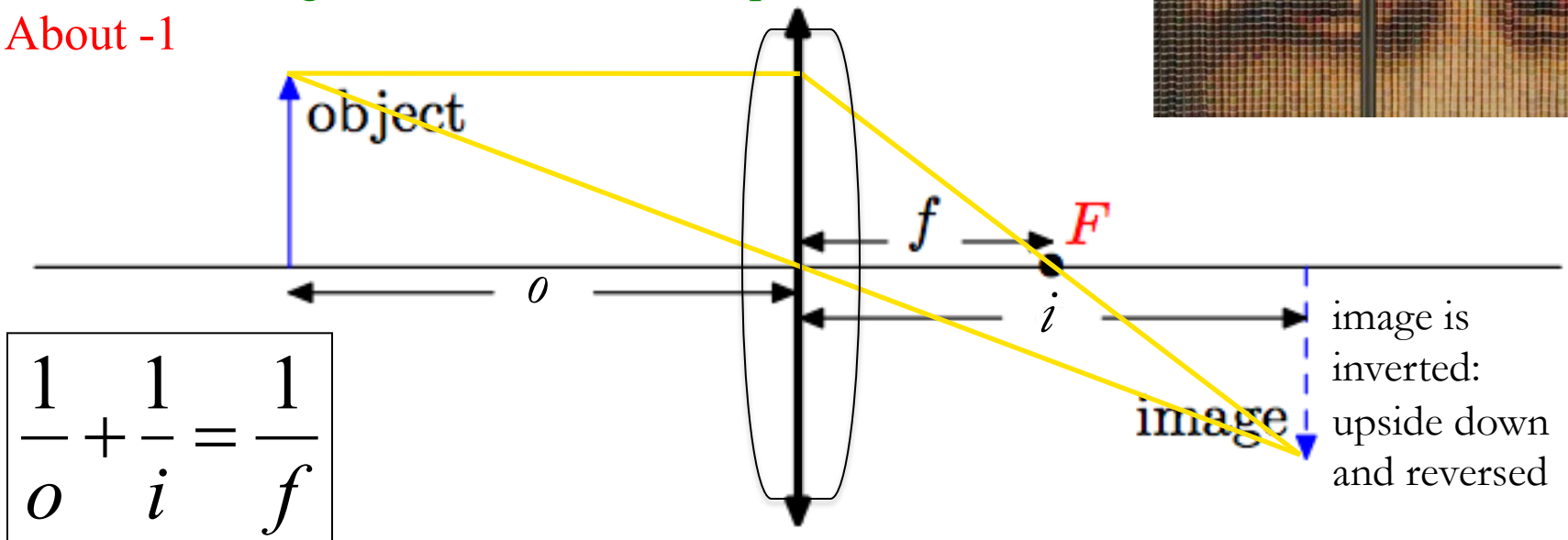

$$\frac{1}{o} + \frac{1}{i} = \frac{1}{f}$$

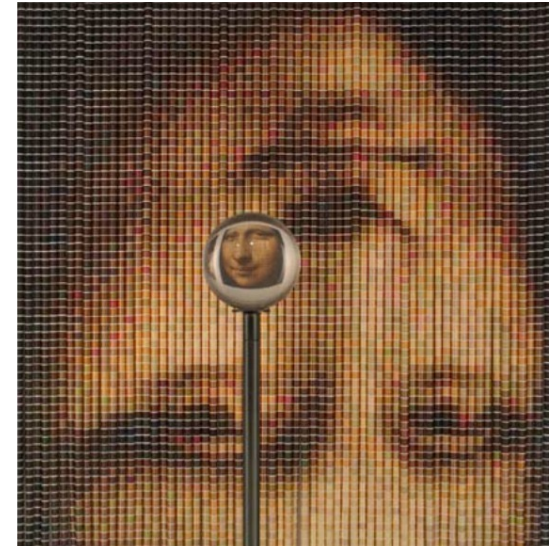

# Basic Optics

- ◆ Linear magnification (linear dimensions of image relative to object) of a lens or mirror is given by the formula

$$m = -\frac{i}{o}$$

where  $m < 0$  if the image is inverted

$m > 0$  if the image is upright

$|m| > 1$  if enlarged

- ◆ How could you achieve a smaller linear magnification, as in the picture on the right?

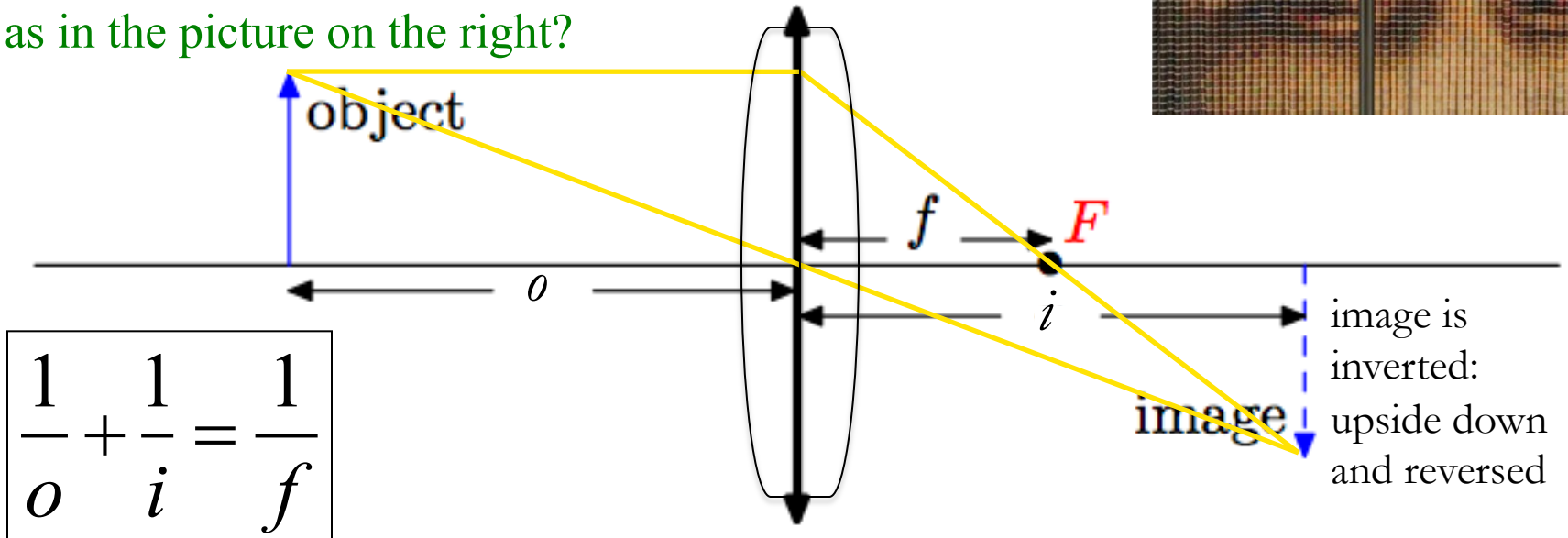
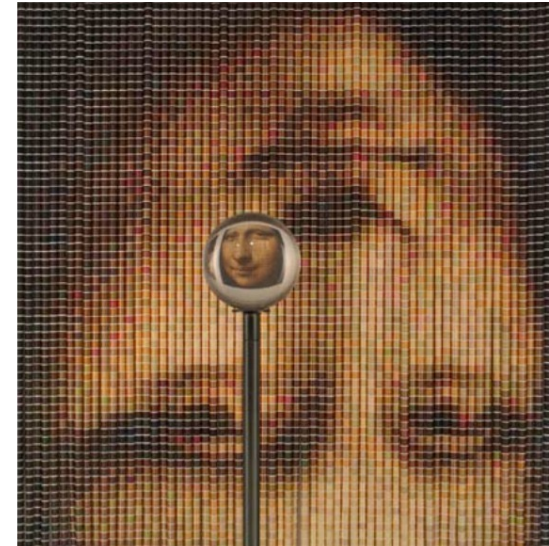

$$\frac{1}{o} + \frac{1}{i} = \frac{1}{f}$$



# Basic Optics

- ◆ Linear magnification (linear dimensions of image relative to object) of a lens or mirror is given by the formula

$$m = -\frac{i}{o}$$

where  $m < 0$  if the image is inverted

$m > 0$  if the image is upright

$|m| > 1$  if enlarged

- ◆ How could you achieve a smaller linear magnification, as in the picture on the right? Place lens further away from the object.

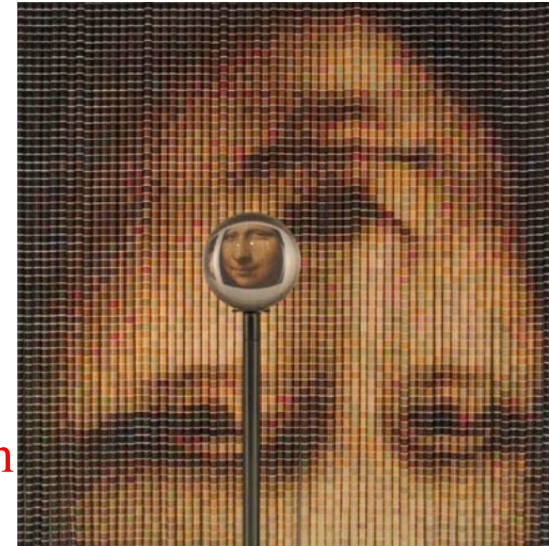
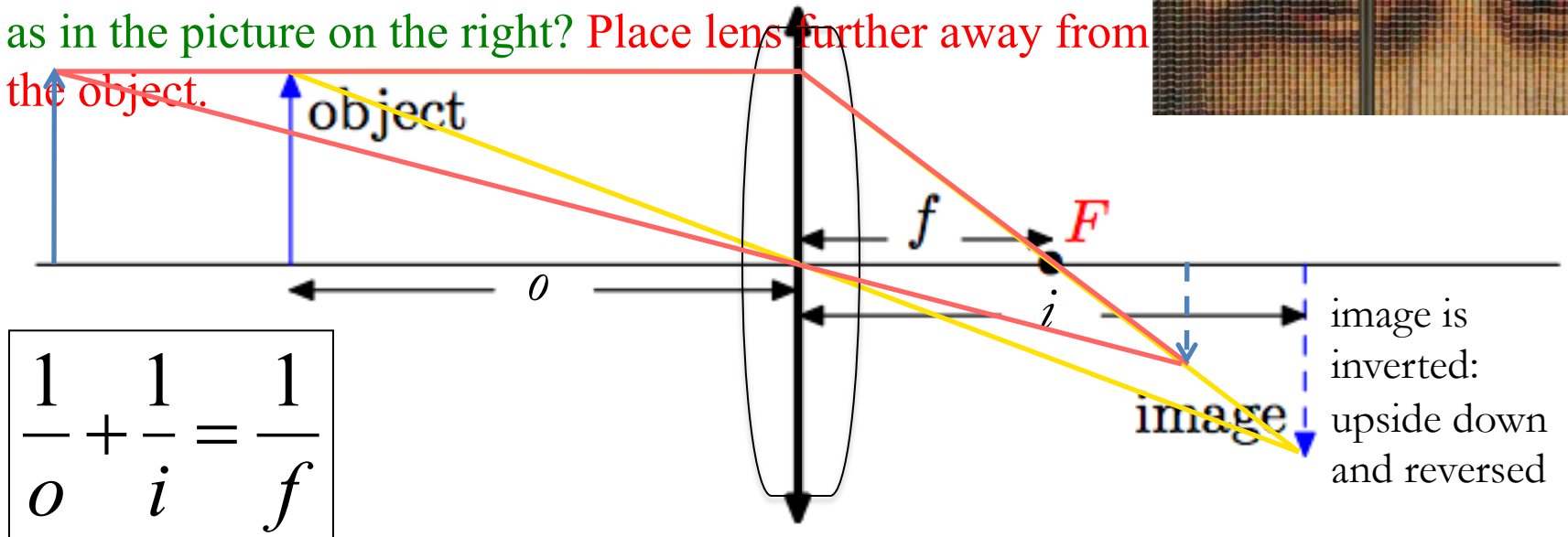

$$\frac{1}{o} + \frac{1}{i} = \frac{1}{f}$$

# Basic Optics

- ◆ Linear magnification of a lens or mirror is given by the formula

$$m = -\frac{i}{o}$$

where  $m < 0$  if the image is inverted

$m > 0$  if the image is upright

$|m| > 1$  if enlarged

- ◆ A magnifying glass uses a biconvex lens. In this example, where would you place your eye and where does the image appear to be located?

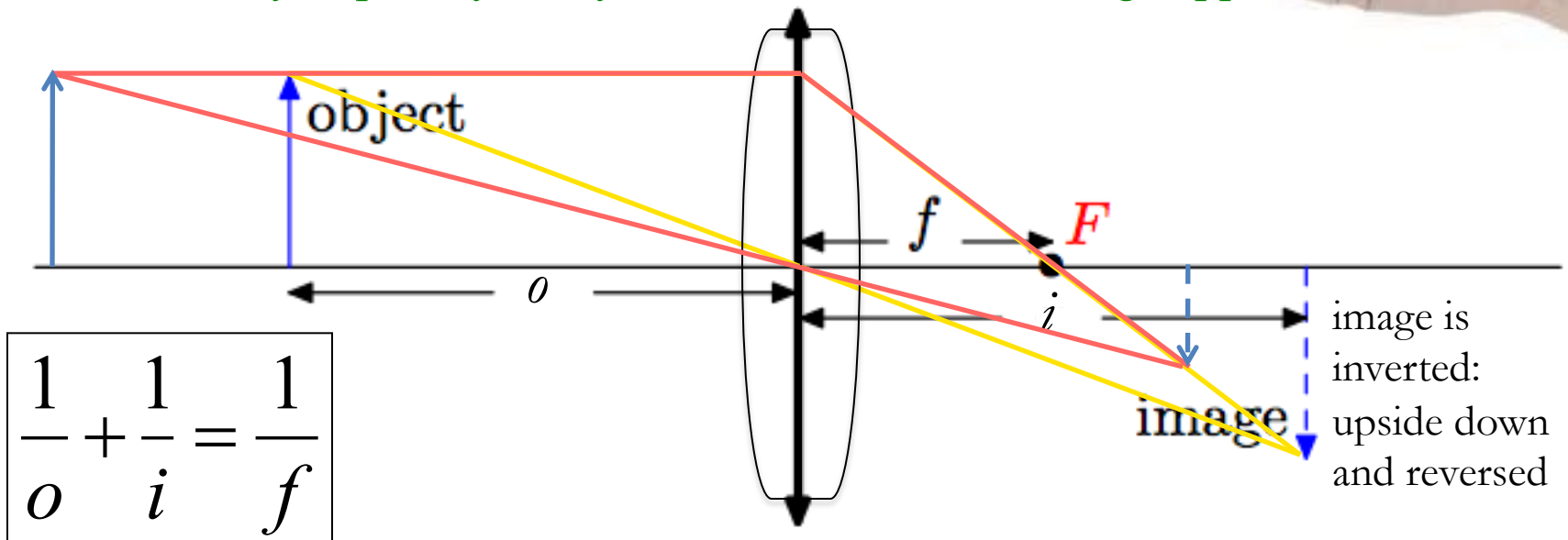

$$\frac{1}{o} + \frac{1}{i} = \frac{1}{f}$$

# Basic Optics

- ◆ Linear magnification of a lens or mirror is given by the formula

$$m = -\frac{i}{o}$$

where  $m < 0$  if the image is inverted

$m > 0$  if the image is upright

$|m| > 1$  if enlarged

- ◆ A magnifying glass uses a biconvex lens. In this example, where would you place your eye and where does the image appear to be located? Beyond the image location, where the rays diverge. Image appears where the rays converge.

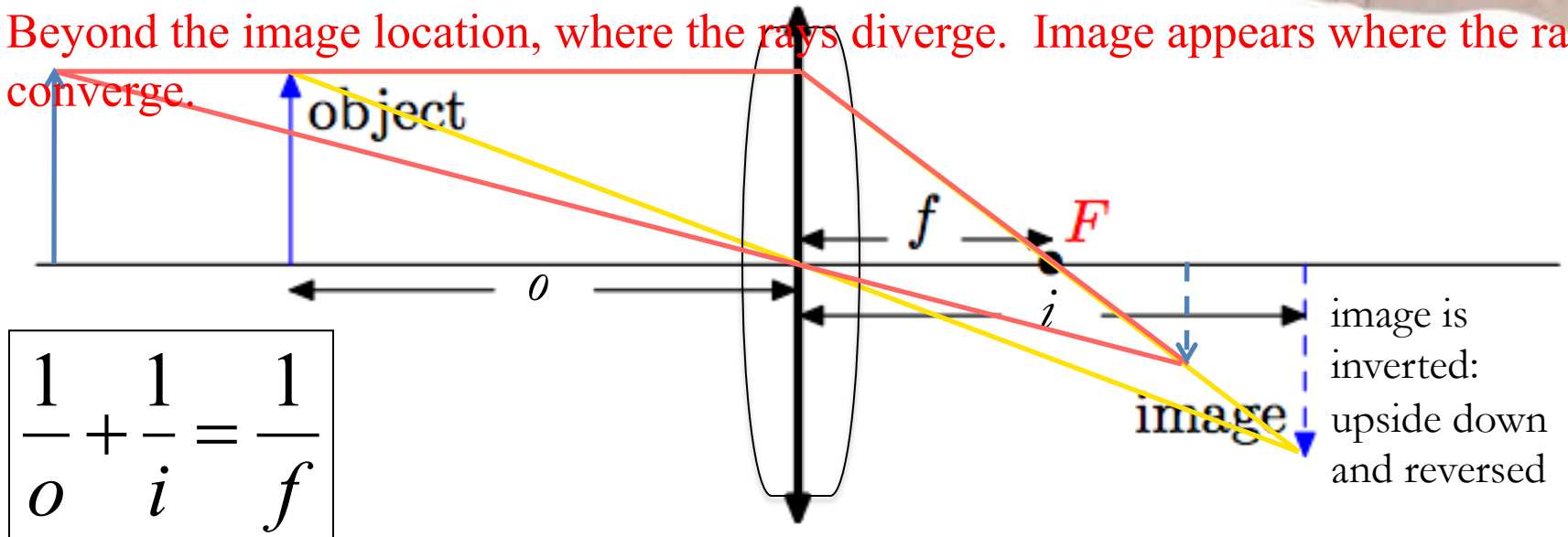

# Basic Optics

- ◆ Linear magnification of a lens or mirror is given by the formula

$$m = -\frac{i}{o}$$

where  $m < 0$  if the image is inverted

$m > 0$  if the image is upright

$|m| > 1$  if enlarged

- ◆ A magnifying glass uses a biconvex lens. Where would you need to place the lens relative to the object to get a high linear magnification?

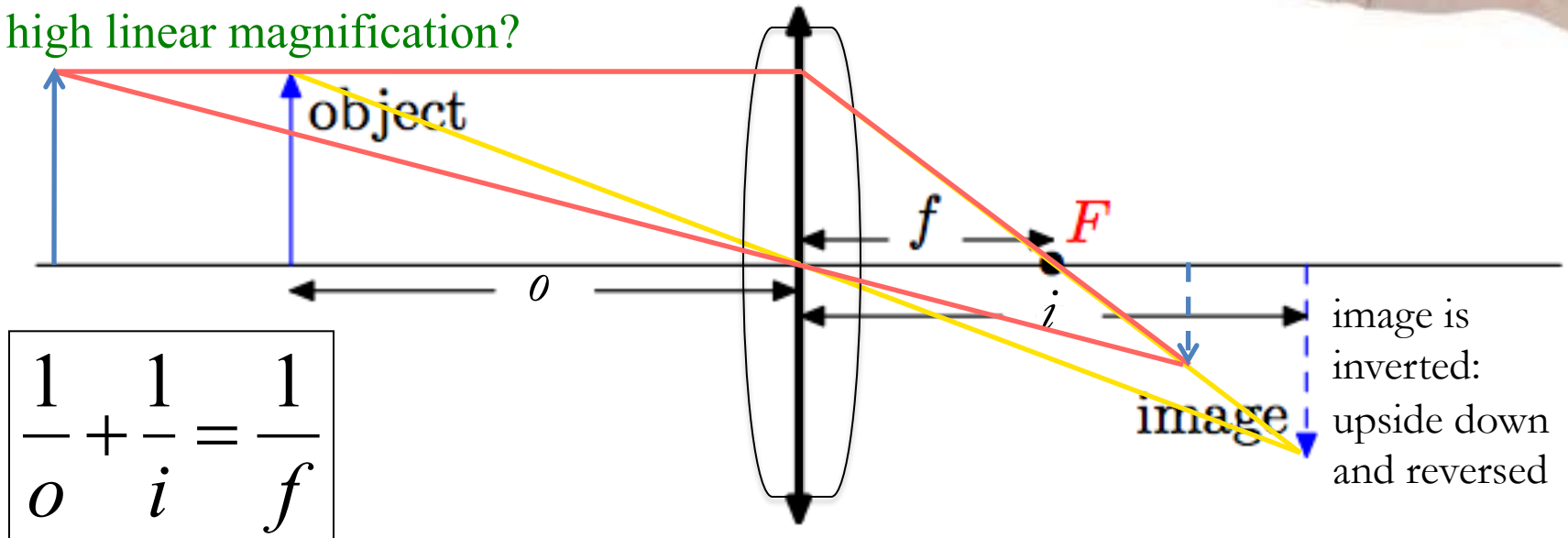

$$\frac{1}{o} + \frac{1}{i} = \frac{1}{f}$$



# Basic Optics

- ◆ Linear magnification of a lens or mirror is given by the formula

$$m = -\frac{i}{o}$$

where  $m < 0$  if the image is inverted  
 $m > 0$  if the image is upright  
 $|m| > 1$  if enlarged

- ◆ A magnifying glass uses a biconvex lens. Where would you need to place the lens relative to the object to get a high linear magnification? **Close to the object.**

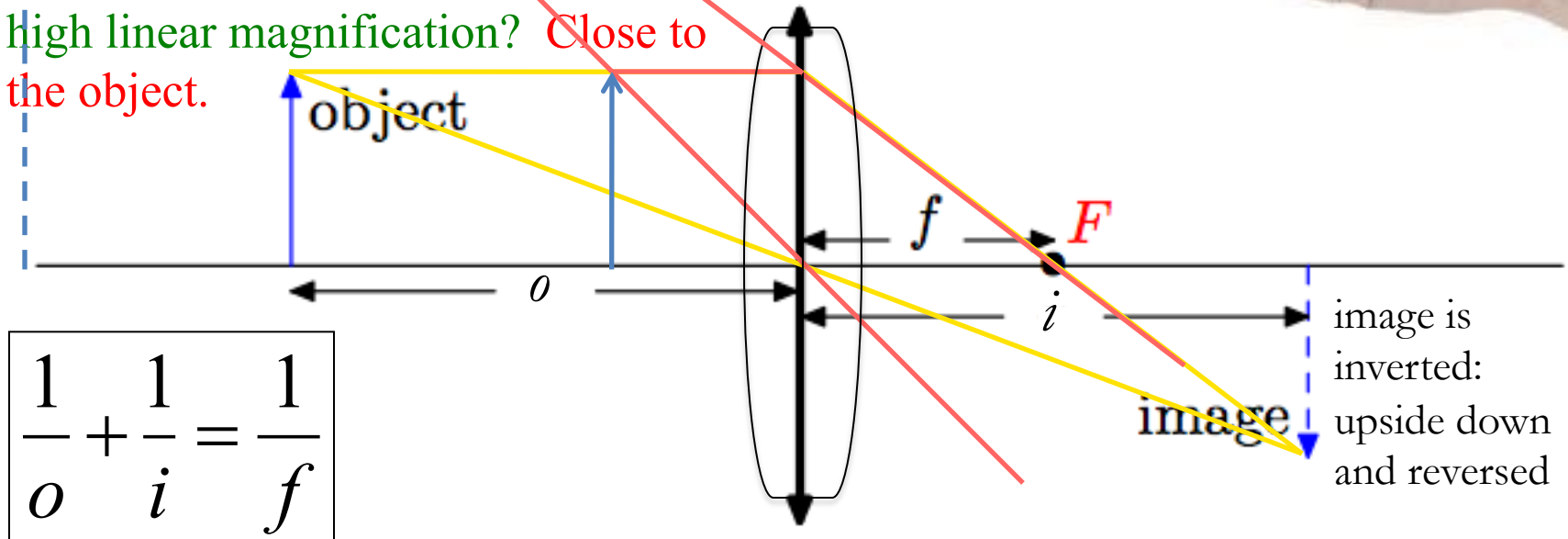

$$\frac{1}{o} + \frac{1}{i} = \frac{1}{f}$$



image is inverted:  
upside down  
and reversed

# Basic Optics

- ◆ A biconvex lens used in such a manner forms an upright virtual image.

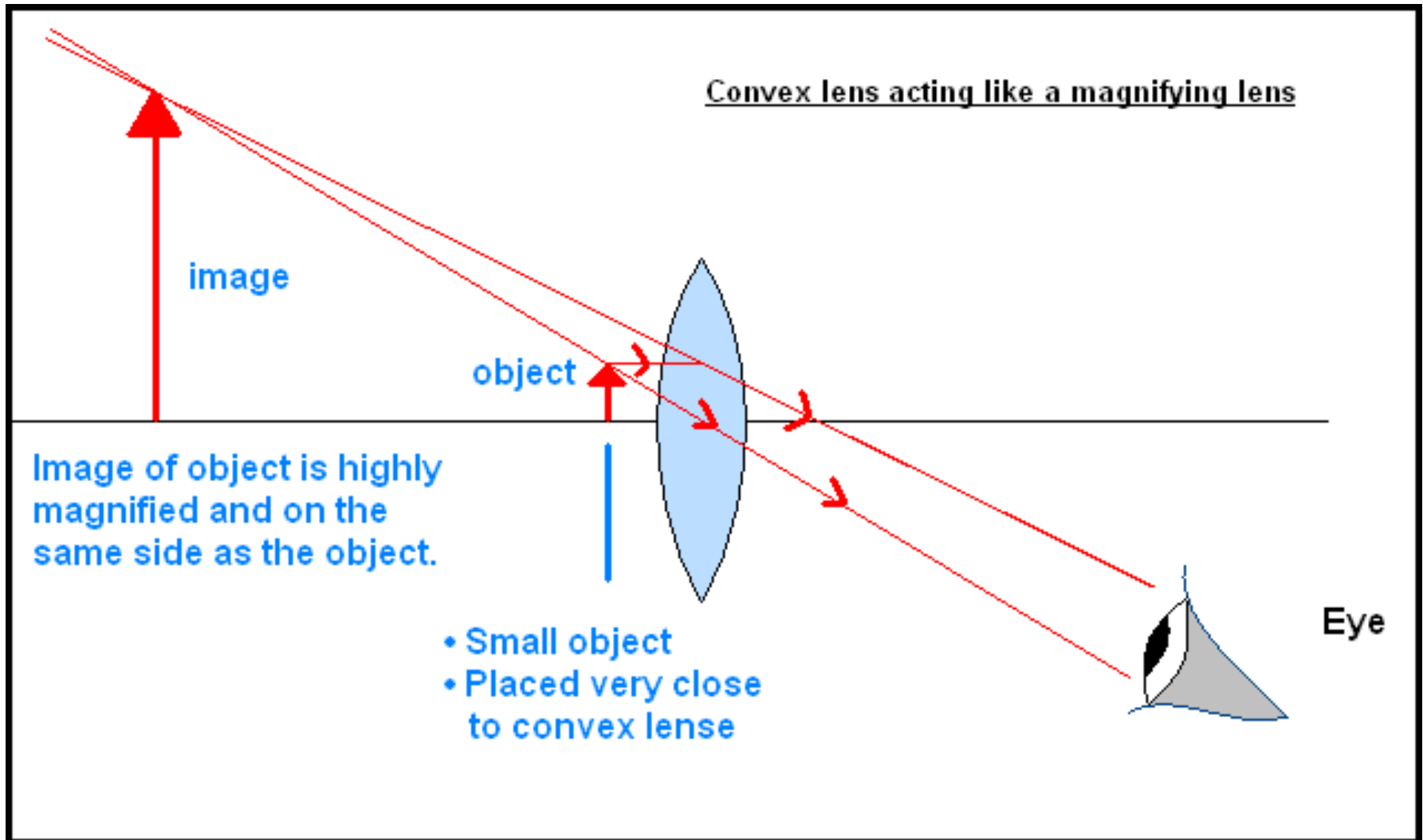

# Basic Optics

- ◆ Linear magnification of a lens or mirror is given by the formula

$$m = -\frac{i}{o}$$

where  $m < 0$  if the image is inverted

$m > 0$  if the image is upright

$|m| > 1$  if enlarged

- ◆ Do lenses with shorter or longer focal lengths produce larger images?

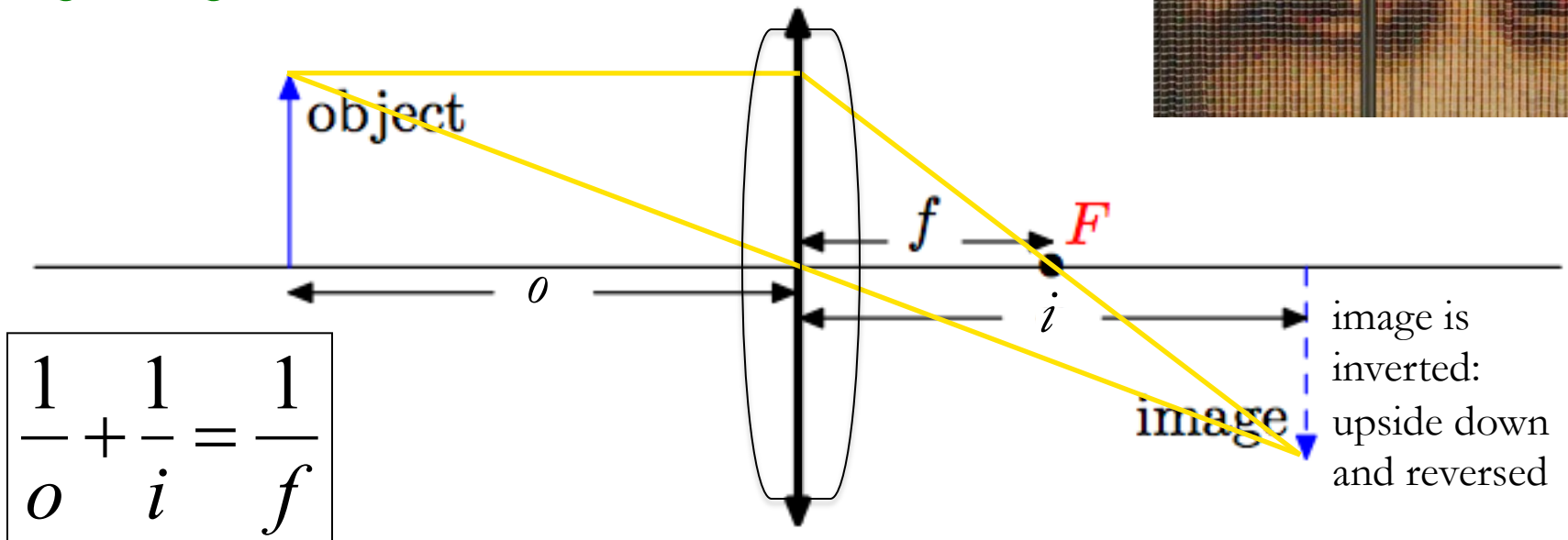
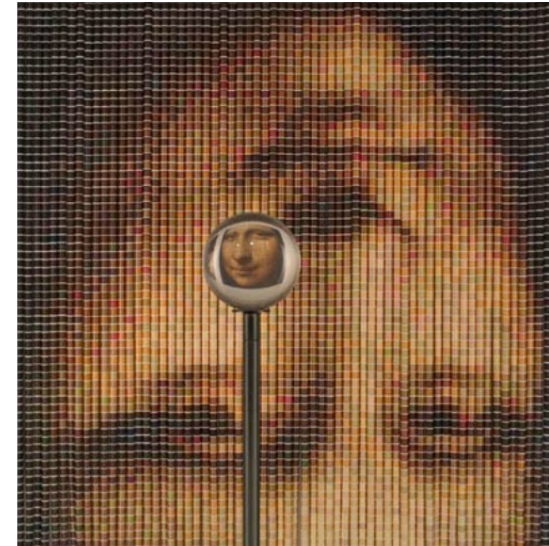

$$\frac{1}{o} + \frac{1}{i} = \frac{1}{f}$$

# Basic Optics

- ◆ Linear magnification of a lens or mirror is given by the formula

$$m = -\frac{i}{o}$$

where  $m < 0$  if the image is inverted

$m > 0$  if the image is upright

$|m| > 1$  if enlarged

- ◆ Do lenses with shorter or longer focal lengths produce larger images? **Longer  $f$**

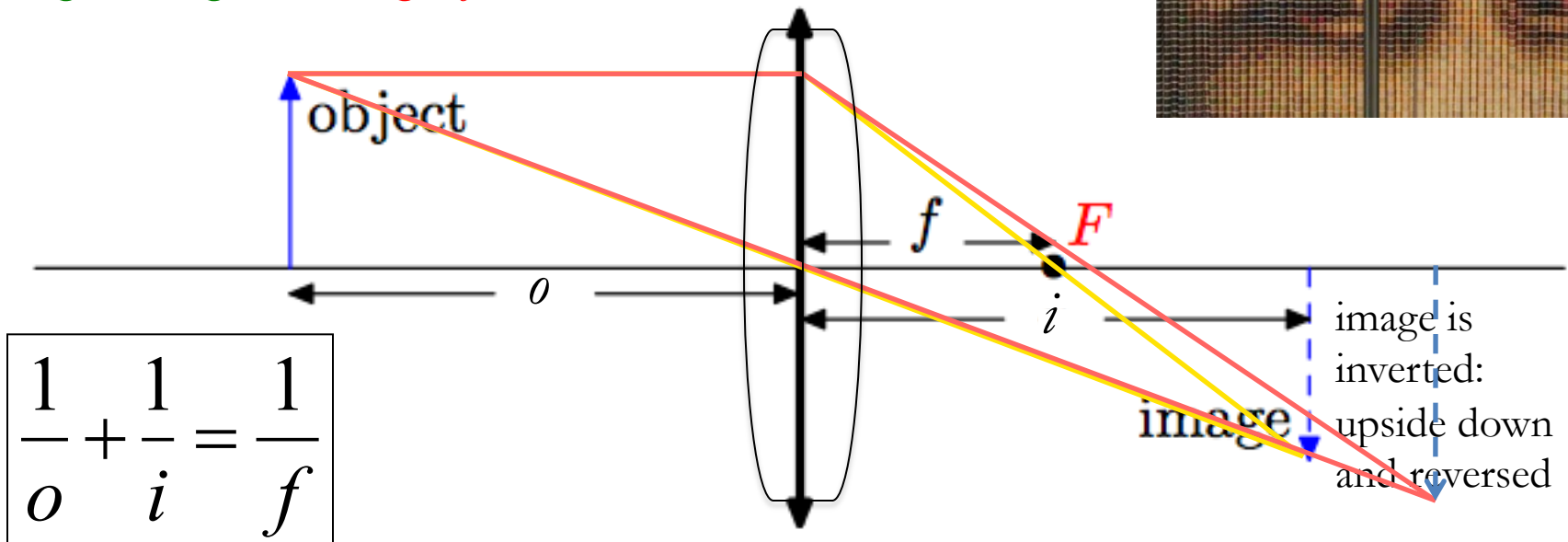
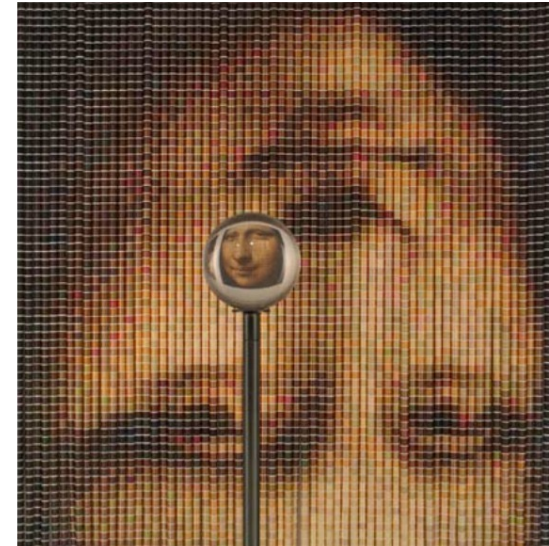

$$\frac{1}{o} + \frac{1}{i} = \frac{1}{f}$$



# Basic Optics

---

- ◆ Linear magnification of a lens or mirror is given by the formula

$$m = -\frac{i}{o}$$

where  $m < 0$  if the image is inverted

$m > 0$  if the image is upright

$|m| > 1$  if enlarged

- ◆ Do lenses with shorter or longer focal lengths produce larger images? **Longer  $f$**

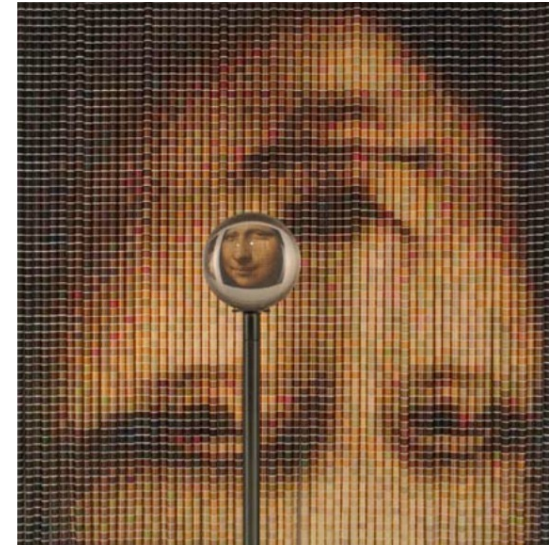

# Basic Optics

---

- ◆ Linear magnification of a lens or mirror is given by the formula

$$m = -\frac{i}{o}$$

where  $m < 0$  if the image is inverted

$m > 0$  if the image is upright

$|m| > 1$  if enlarged

- ◆ What linear magnifications (in absolute numbers) do telescopes produce?

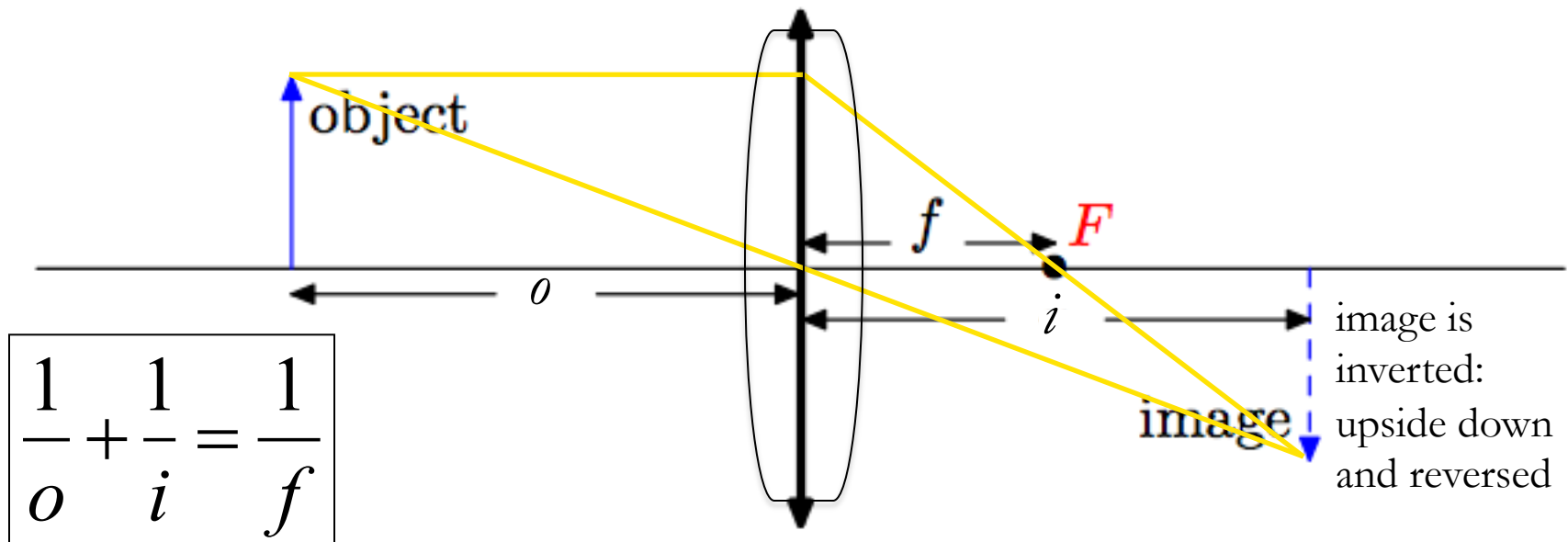

# Basic Optics

---

- ◆ **Much less than 1.** Linear magnification is not a particularly useful measure for telescopes. Angular magnification is a more useful measure, and its derivation is related to linear magnification.

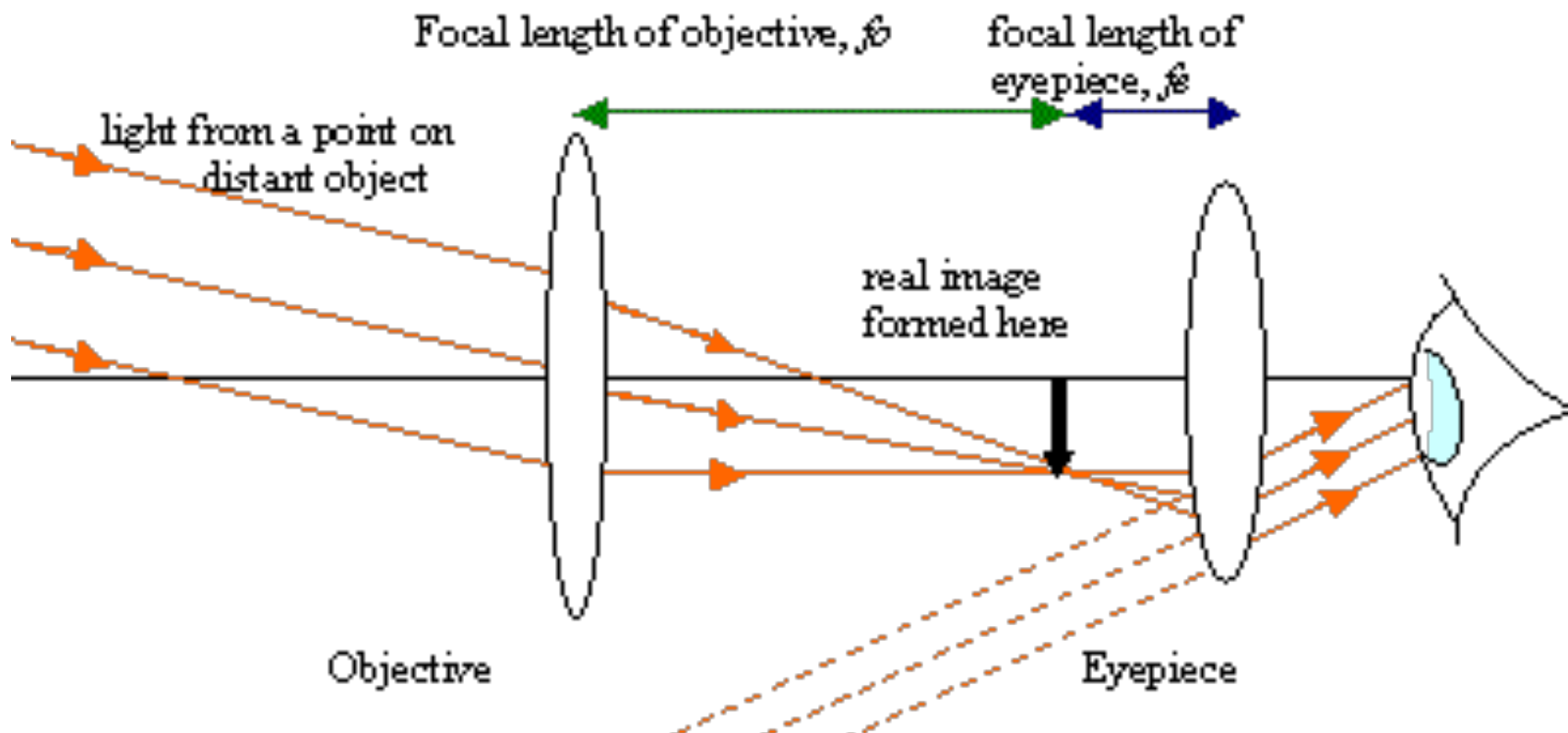

# Learning Objectives

---

- ◆ Telescopes:
  - main types, primary components, and inner workings
  - primary functions
- ◆ Review of Basic Optics:
  - lens and mirror formulae
  - photography versus viewing
  - linear magnification
- ◆ Telescope Optics:
  - focal ratio
  - image size and plate scale
  - field of view at focal plane
  - angular magnification through eyepiece
  - true vs. apparent field of view of eyepiece
  - exit pupil

# Focal Ratio

---

- ◆ What does the focal ratio (f/ number) of a lens, mirror, or telescope mean?



Camera lens



Keck Telescopes

## Keck Telescope Specifications

### Telescope

Optical design:	Ritchey-Chretien
Mount:	Altazimuth
Overall height:	24.6 meters
Total moving weight:	270 tons
Total weight of glass:	14.4 tons

### Primary mirror:

Design:	Actively controlled, segmented hexagon
Equivalent diameter:	10 meters
Figure:	Concave hyperboloid
Number of segments:	36
Segment diameter:	1.8 meters
Segment thickness:	75 mm
Segment weight:	400 kg
Gap between segments:	3 mm
Segment material:	Zerodur low-expansion glass-ceramic

Light collecting area:	76 square meters
Focal ratio:	f/1.75

# Focal Ratio

---

- ◆ Focal ratio (f/ number) is defined as

$$\text{Focal ratio} = \frac{\text{Focal length of primary}}{\text{Aperture diameter of primary}}$$

- ◆ What is the focal length of the (objective mirror of the) Keck telescope?

## Keck Telescope Specifications

### Primary mirror:

Design:	Actively controlled, segmented hexagon
Equivalent diameter:	10 meters
Figure:	Concave hyperboloid
Number of segments:	36
Segment diameter:	1.8 meters
Segment thickness:	75 mm
Segment weight:	400 kg
Gap between segments:	3 mm
Segment material:	Zerodur low-expansion glass-ceramic
Light collecting area:	76 square meters
Focal ratio:	f/1.75

# Focal Ratio

---

- ◆ Focal ratio (f/ number) is defined as

$$\text{Focal ratio} = \frac{\text{Focal length of primary}}{\text{Aperture diameter of primary}}$$

- ◆ What is the focal length of the (objective mirror of the) Keck telescope? **17.5 m**
- ◆ The term focal ratio (f/ number) has its roots in photography, and is a quantitative measure of the lens speed (the exposure time to achieve the same image brightness).

## Keck Telescope Specifications

### Primary mirror:

Design:	Actively controlled, segmented hexagon
Equivalent diameter:	10 meters
Figure:	Concave hyperboloid
Number of segments:	36
Segment diameter:	1.8 meters
Segment thickness:	75 mm
Segment weight:	400 kg
Gap between segments:	3 mm
Segment material:	Zerodur low-expansion glass-ceramic

Light collecting area: 76 square meters  
Focal ratio: f/1.75

# Image Size at Focal Plane

---

- ◆ Linear size of an image at the focal plane is given by

$$y = f \tan \theta$$
$$\cong f \theta$$

- ◆ If you wish to have a larger image, would you choose a telescope with a shorter or longer focal length?

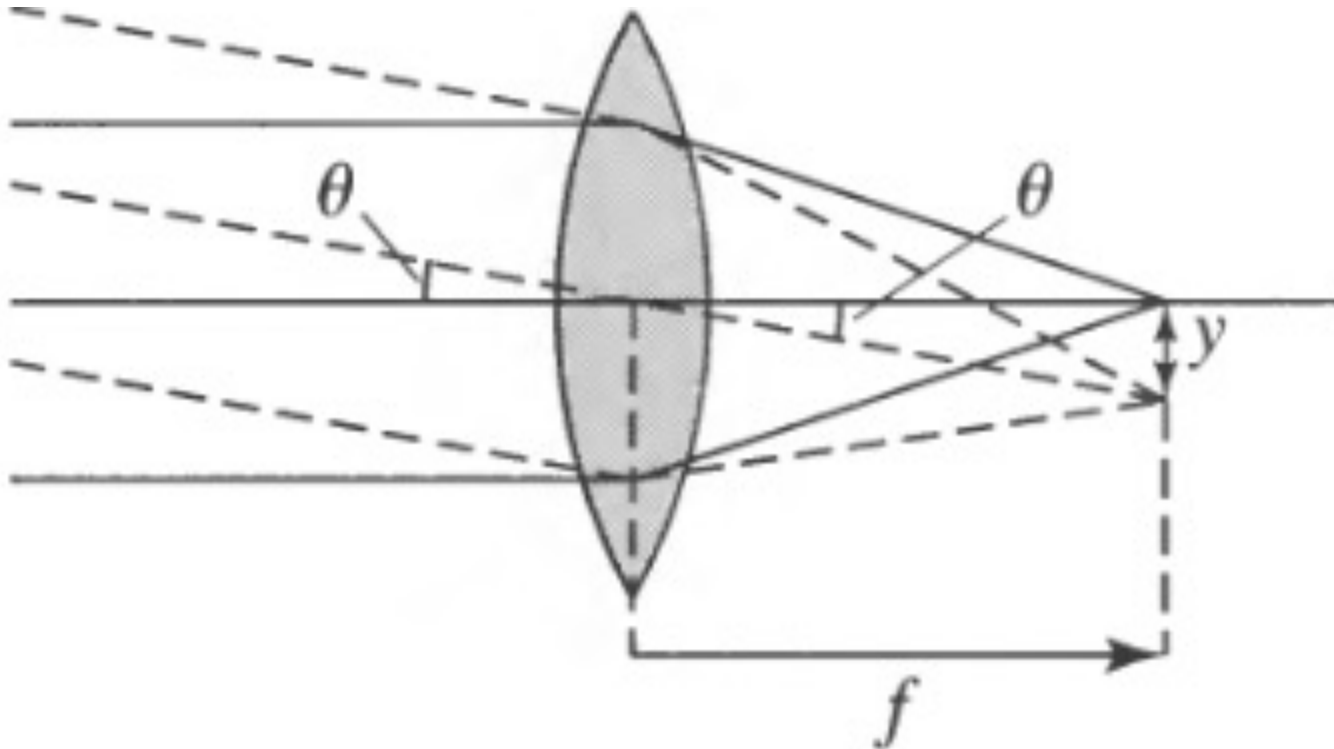



# Image Size at Focal Plane

---

- ◆ Linear size of an image at the focal plane is given by

$$y = f \tan \theta$$
$$\cong f \theta$$

- ◆ If you wish to have a larger image, would you choose a telescope with a shorter or longer focal length? **Longer focal length; i.e. higher linear magnification**

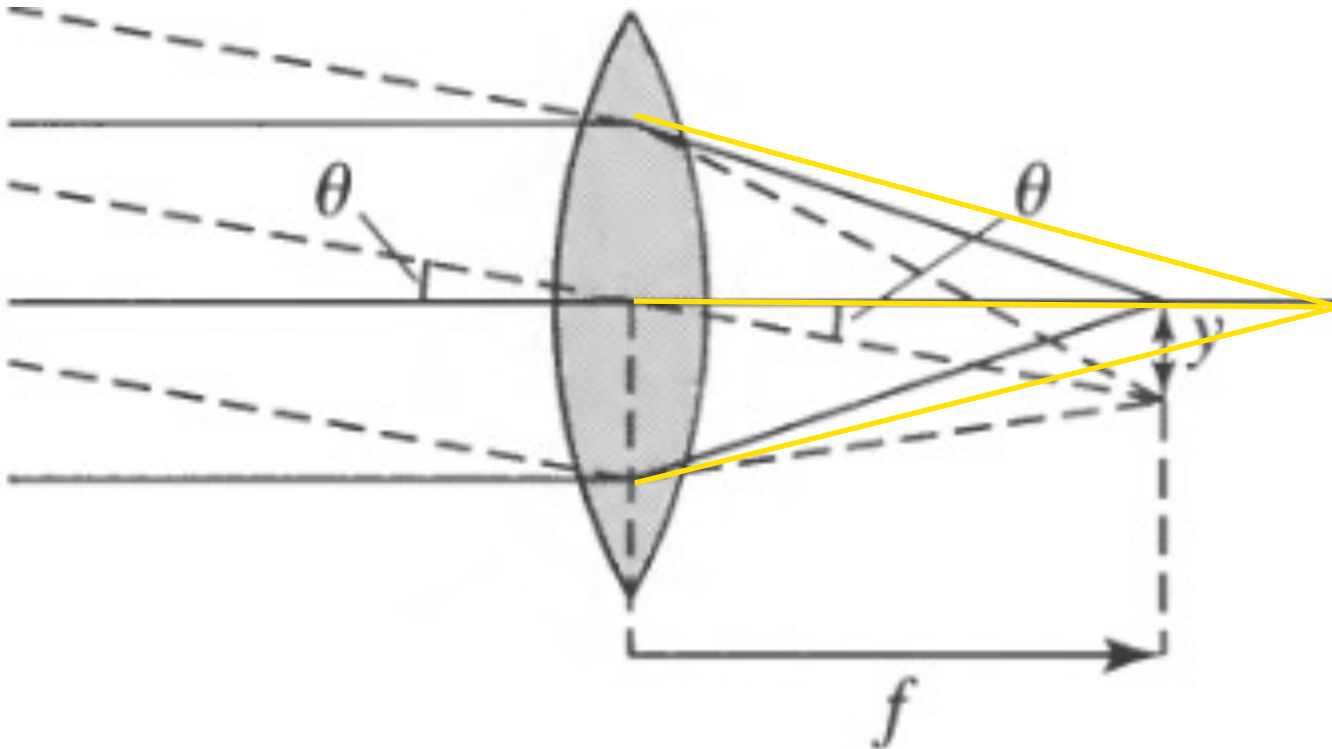

# Image Size at Focal Plane

---

- ◆ Linear size of an image at the focal plane is given by

$$y = f \tan \theta$$
$$\cong f \theta$$

- ◆ If you wish to have a larger image, would you choose a telescope with a shorter or longer focal length? **Longer focal length; i.e. higher linear magnification**

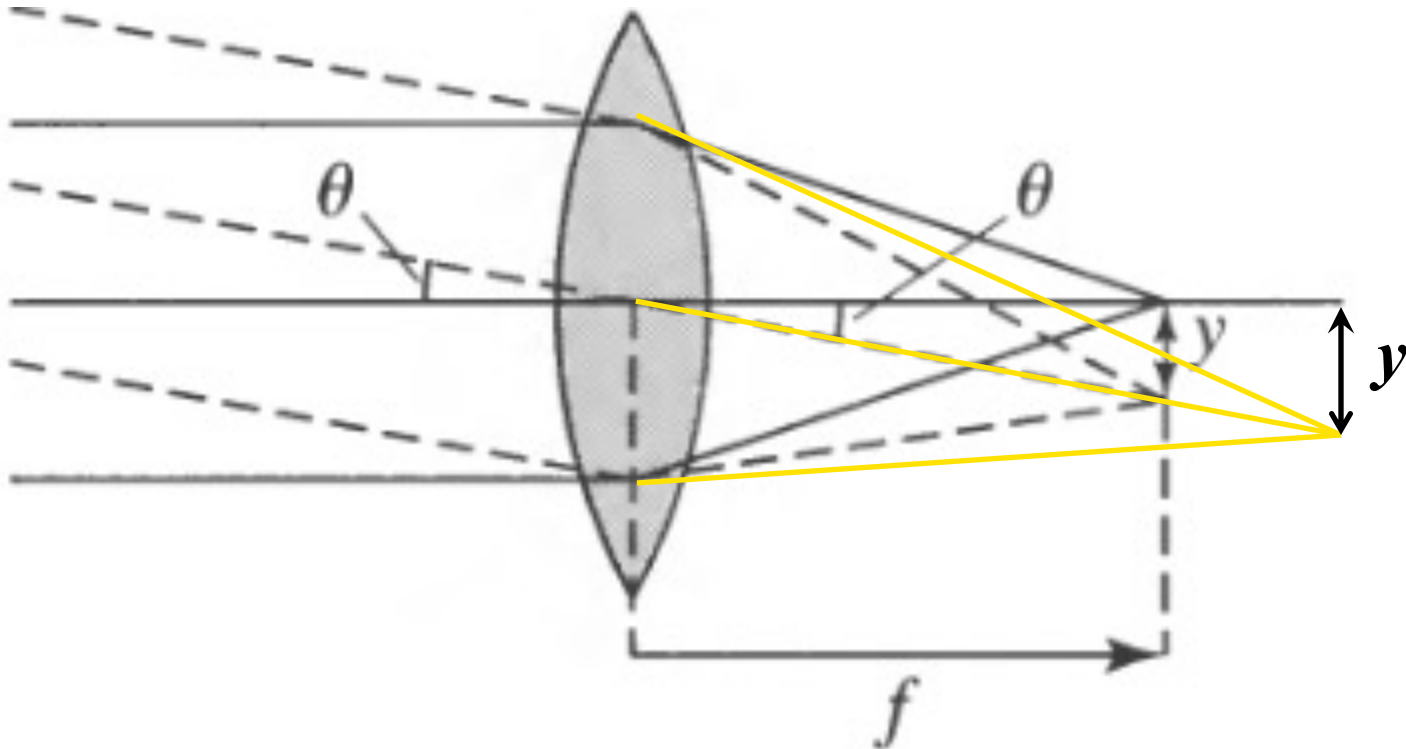

# Image Size at Focal Plane

---

- ◆ Linear size of an image at the focal plane is given by

$$y = f \tan \theta$$
$$\cong f \theta$$

- ◆ Plate scale is defined as

$$\theta/y = 1/f$$

e.g., 2.9"/mm (" = arcseconds).

# Plate Scale

---

- ◆ Each of the twin Keck 10-m telescopes have a focal length of 17.5 m. If looking at an astronomical object that subtends  $60'' = 2.9 \times 10^{-4}$  radians in the sky, **what is the image size at the focal plane?**
- ◆ **What is the plate scale?**

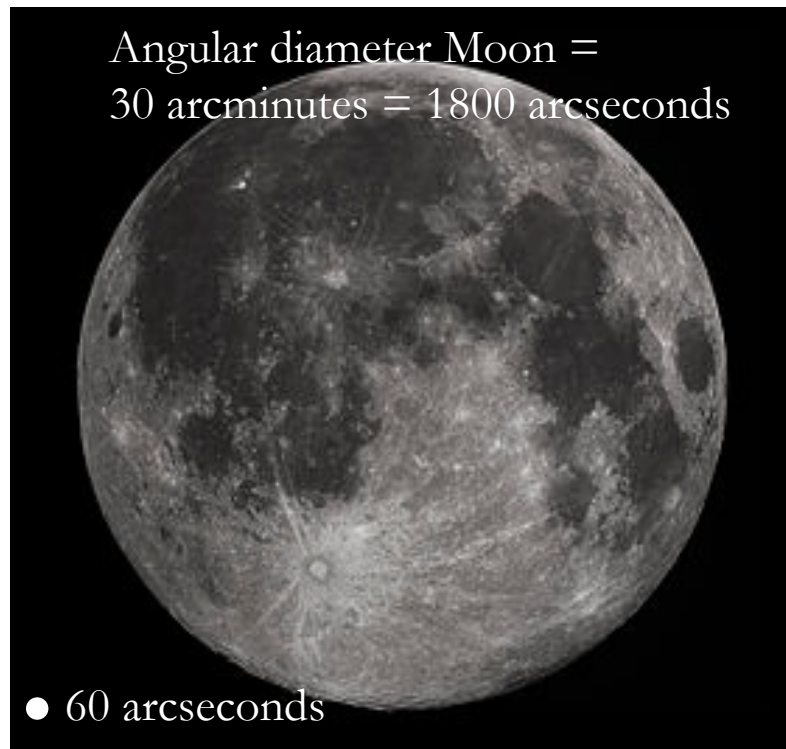

# Plate Scale

---

- ◆ Each of the twin Keck 10-m telescopes have a focal length of 17.5 m. If looking at an astronomical object that subtends  $60'' = 2.9 \times 10^{-4}$  radians in the sky, **what is the image size at the focal plane? 5.1 mm**
- ◆ **What is the plate scale?**

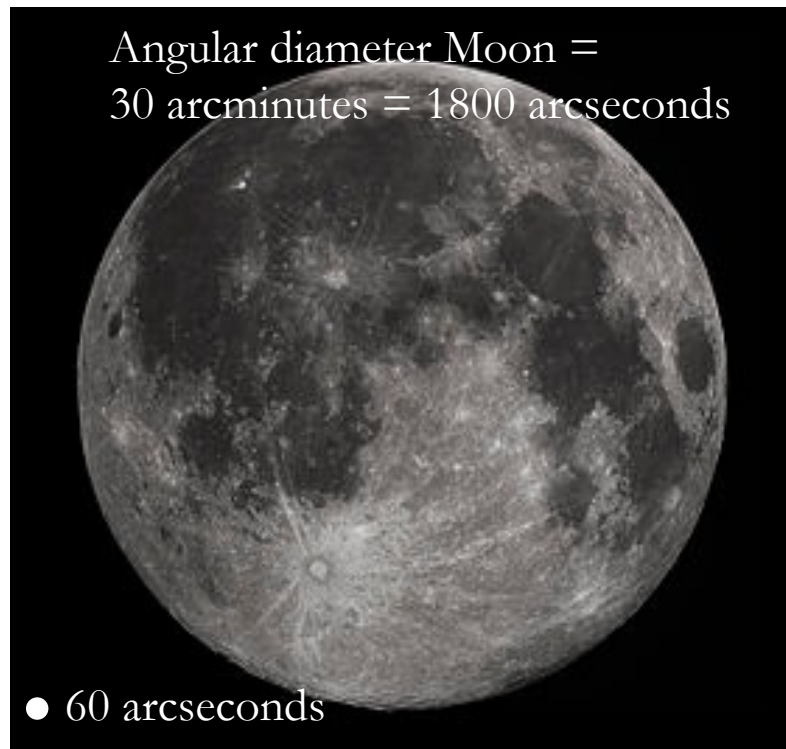

# Plate Scale

---

- ◆ Each of the twin Keck 10-m telescopes have a focal length of 17.5 m. If looking at an astronomical object that subtends  $60'' = 2.9 \times 10^{-4}$  radians in the sky, **what is the image size at the focal plane? 5.1 mm**
- ◆ **What is the plate scale?  $60''/5.1 \text{ mm} = 11.8''/\text{mm}$**

Angular diameter Moon =  
30 arcminutes = 1800 arcseconds



# Field of View at Focal Plane

---

- ◆ Field of view is the angular dimensions of the sky that can be seen or photographed.
- ◆ Field of view can be defined at two points: focal plane (for photography) or eyepiece (for viewing).
- ◆ For a given telescope, what determines the field of view at the focal plane?



# Field of View at Focal Plane

---

- ◆ Field of view is the angular dimensions of the sky that can be seen or photographed.
- ◆ Field of view can be defined at two points: focal plane (for photography) or eyepiece (for viewing).
- ◆ For a given telescope, what determines the field of view at the focal plane?

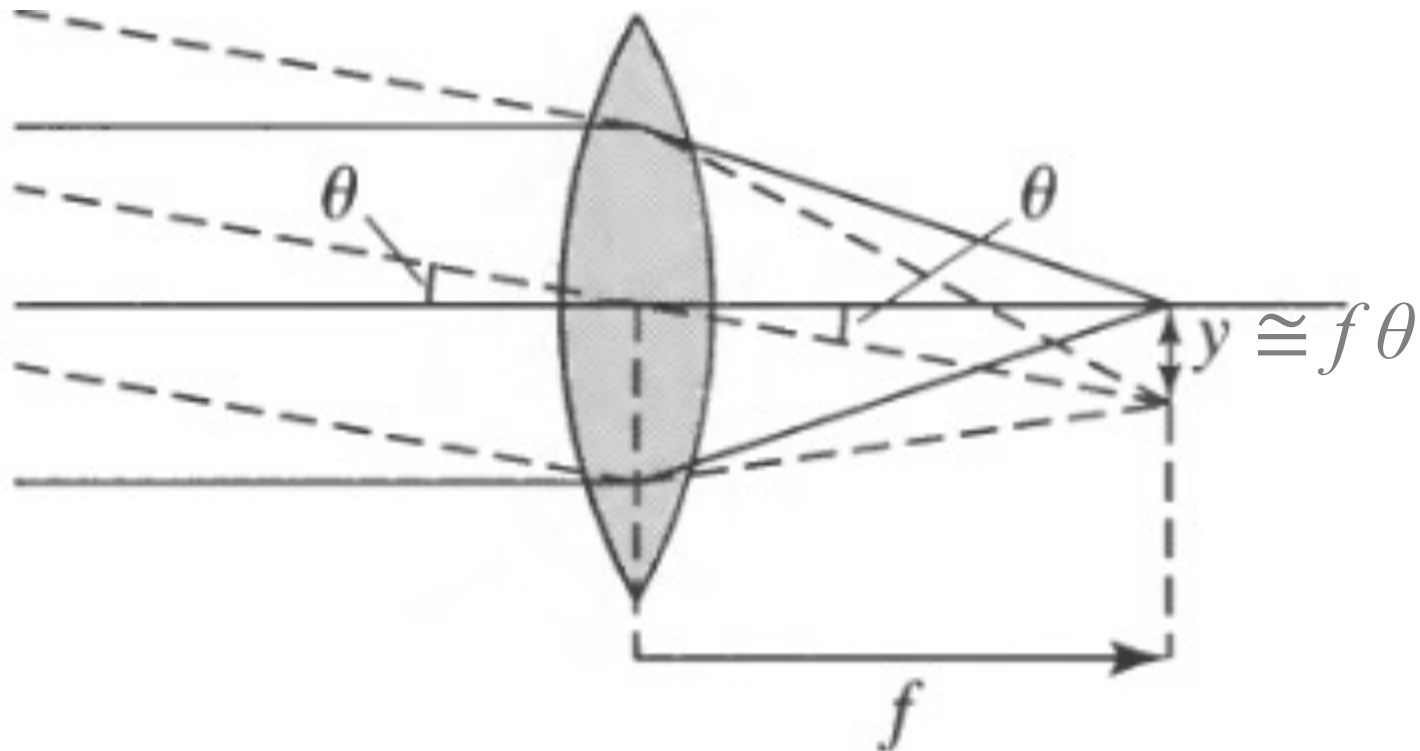



# Field of View at Focal Plane

---

- ◆ Field of view is the angular dimensions of the sky that can be seen or photographed.
- ◆ Field of view can be defined at two points: focal plane (for photography) or eyepiece (for viewing).
- ◆ For a given telescope, what determines the field of view?  
Size (2D-shape) of the detector (e.g., photographic plate or CCD).

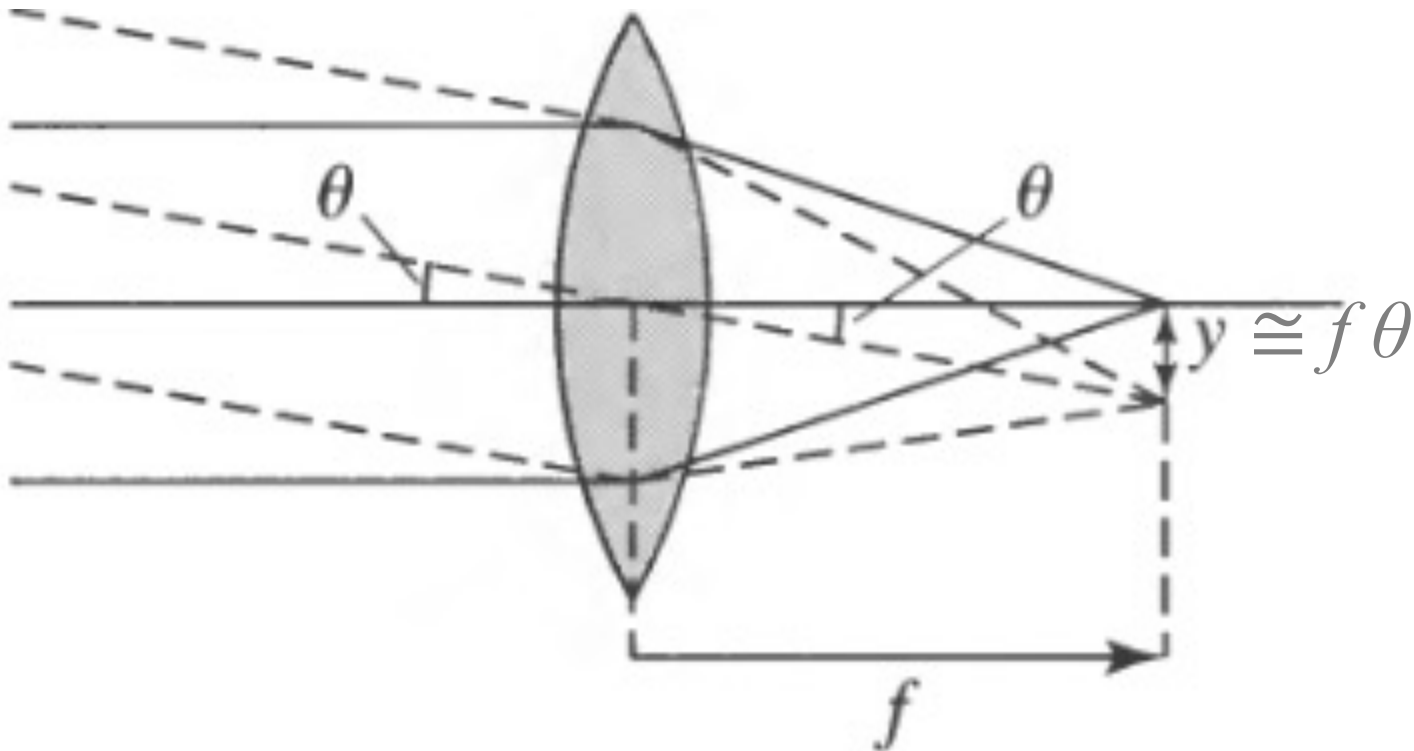

# Field of View at Focal Plane

---

- ◆ Armed with a CCD of a given size but a choice of telescopes, how do you increase the field of view that can be imaged by your CCD?

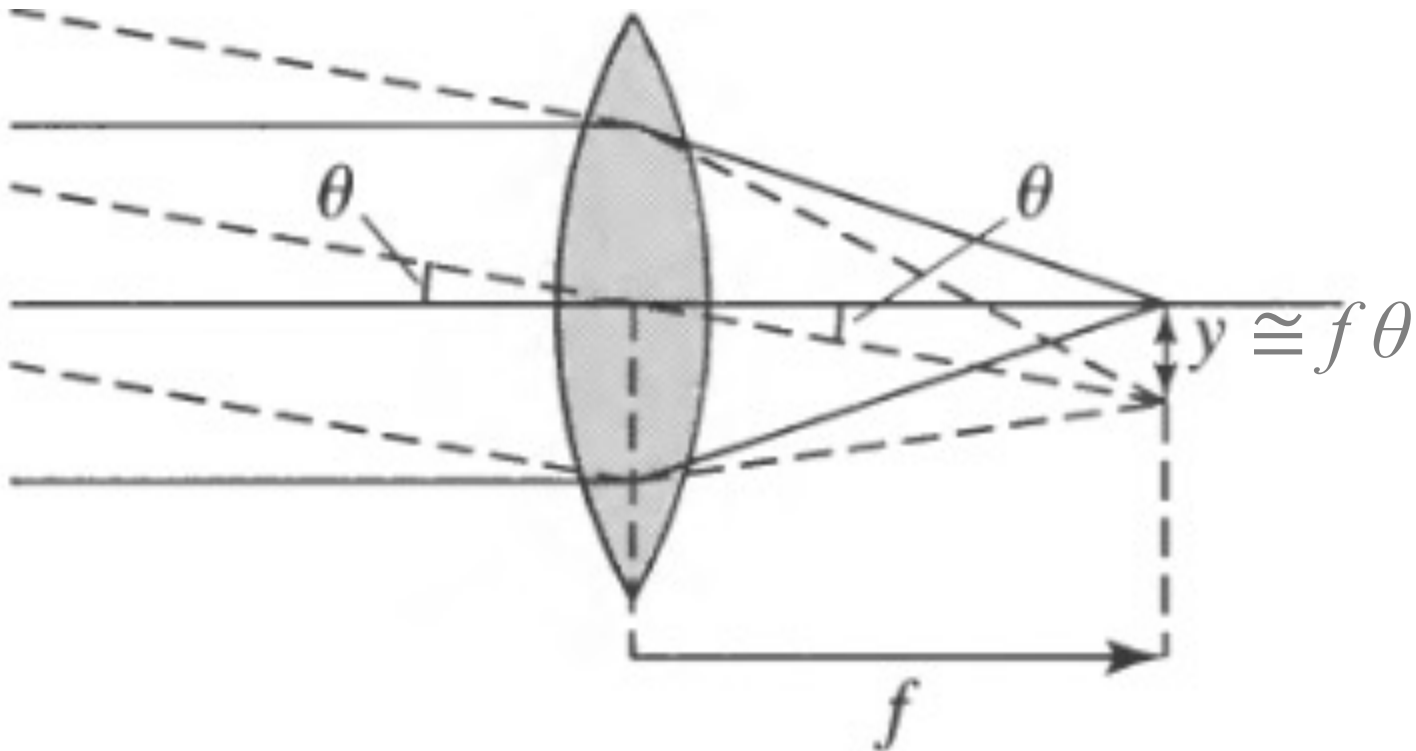

# Field of View at Focal Plane

---

- ◆ Armed with a CCD of a given size but a choice of telescopes, how do you increase the field of view that can be imaged by your CCD? Use a telescope with a shorter focal length; i.e., smaller linear magnification. A smaller linear magnification, however, corresponds to smaller images.

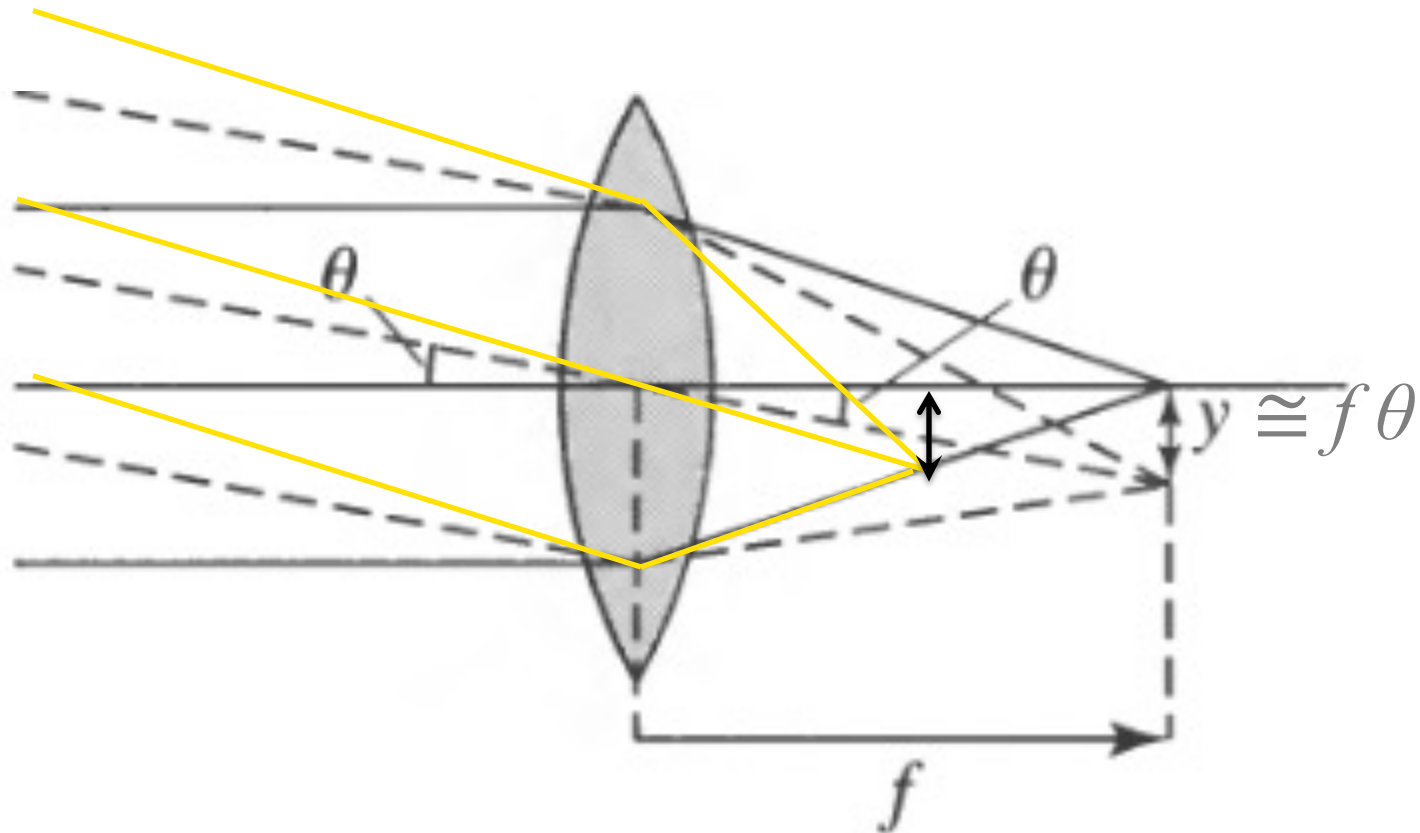

# Field of View at Focal Plane

---

- ◆ Armed with a CCD of a given size but a choice of telescopes, how do you increase the field of view that can be imaged by your CCD? Use a telescope with a shorter focal length; i.e., smaller linear magnification. A smaller linear magnification, however, corresponds to smaller images.

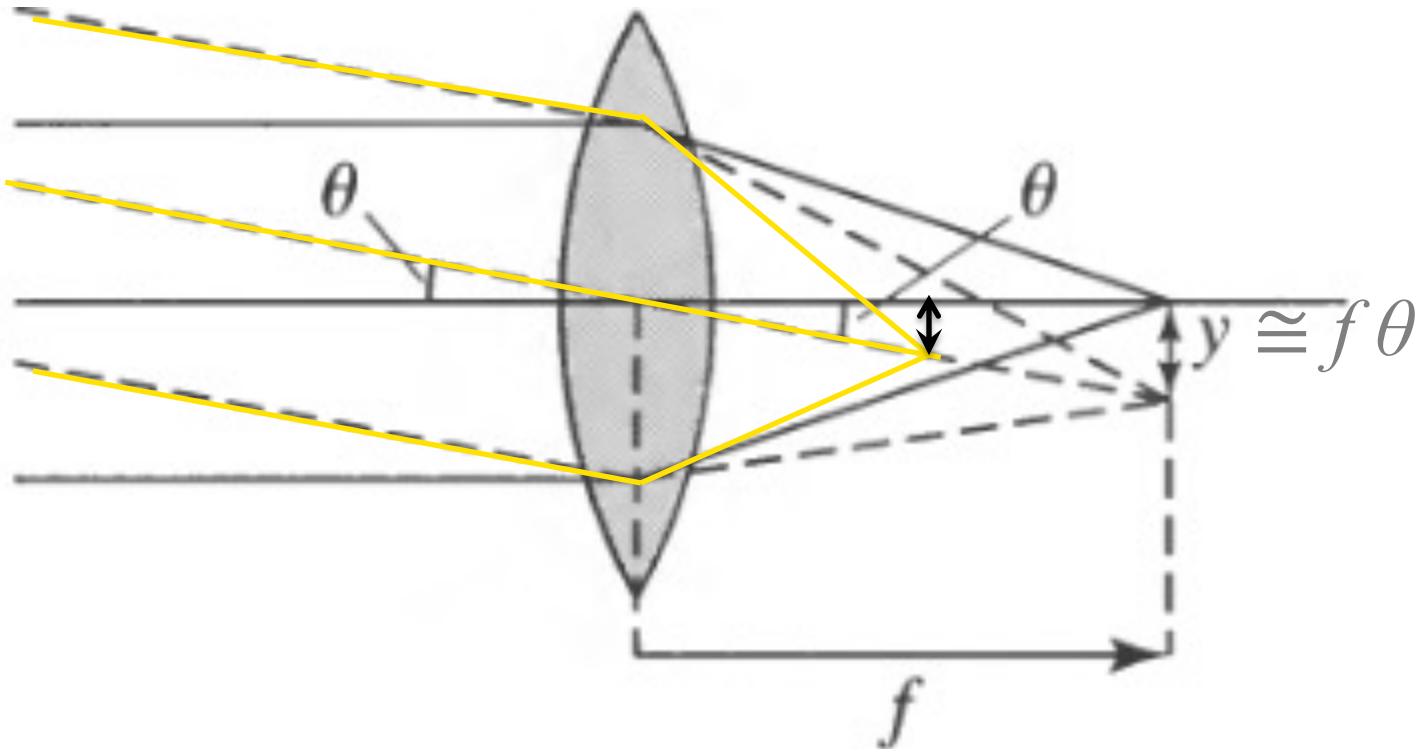

# Lens Speed

---

- ◆ Recall that the focal ratio (f/ number) is defined as

$$\text{Focal ratio} = \frac{\text{Focal length of primary}}{\text{Aperture diameter of primary}}$$

and has its roots in photography as a quantitative measure of the lens speed (the exposure time to achieve the same image brightness).

- ◆ A shorter focal ratio corresponds to a shorter focal length (small image, large field) or a larger aperture, and thus a brighter image (short exposure time).
- ◆ A larger focal ratio corresponds to a longer focal length (large image, small field) or a smaller aperture, and thus a dimmer image (long exposure time)



# Fastscopes

---

- ◆ Fastscopes provide bright images, and so require shorter exposure times to make an image of a given object to the same brightness (light energy per unit area).
- ◆ An example of fastscopes are Schmidt telescopes, which have relatively short focal lengths thus producing small (hence bright) images over large fields of view at the focal plane.
- ◆ Schmidt telescopes are popular among amateur astronomers because they are relatively compact for their aperture sizes (a consequence of their short focal lengths) and provide bright (small) images over rich starfields (wide fields of view).

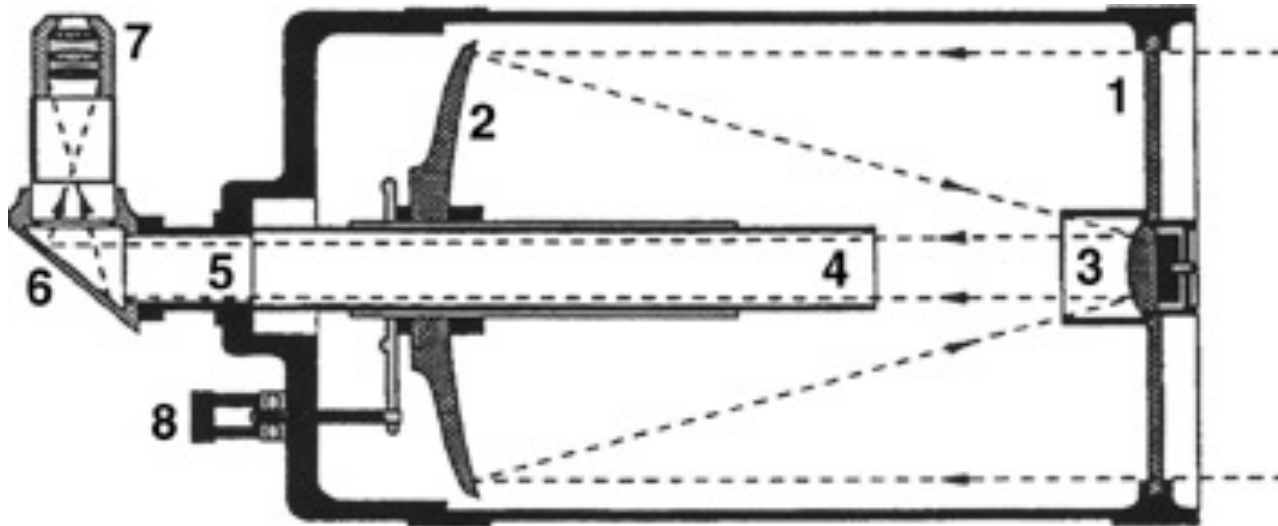

# Fastscopes

---

- ◆ Schmidt telescopes were used by astronomers to study large swaths of the sky or to make sky surveys.
- ◆ One of the most famous sky surveys was the Palomar Observatory Sky Survey that began in 1949 and was completed in 1958. The Survey utilized a 1.2-m Schmidt telescope, recording images on 3.7x3.7-inch glass photographic plates covering  $6.5^\circ \times 6.5^\circ$  each. The Survey was made in a red-sensitive and blue-sensitive plate, is complete to a declination of  $-30^\circ$  at plate centers, and utilized a total of 936 plate pairs.

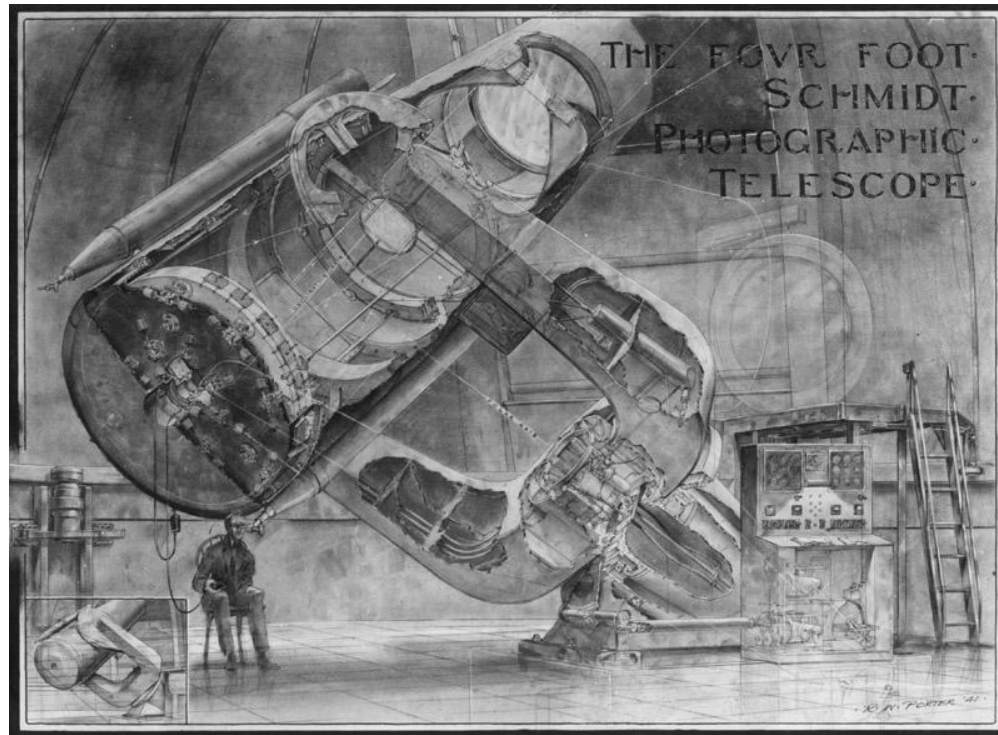

# Angular Magnification through Eyepiece

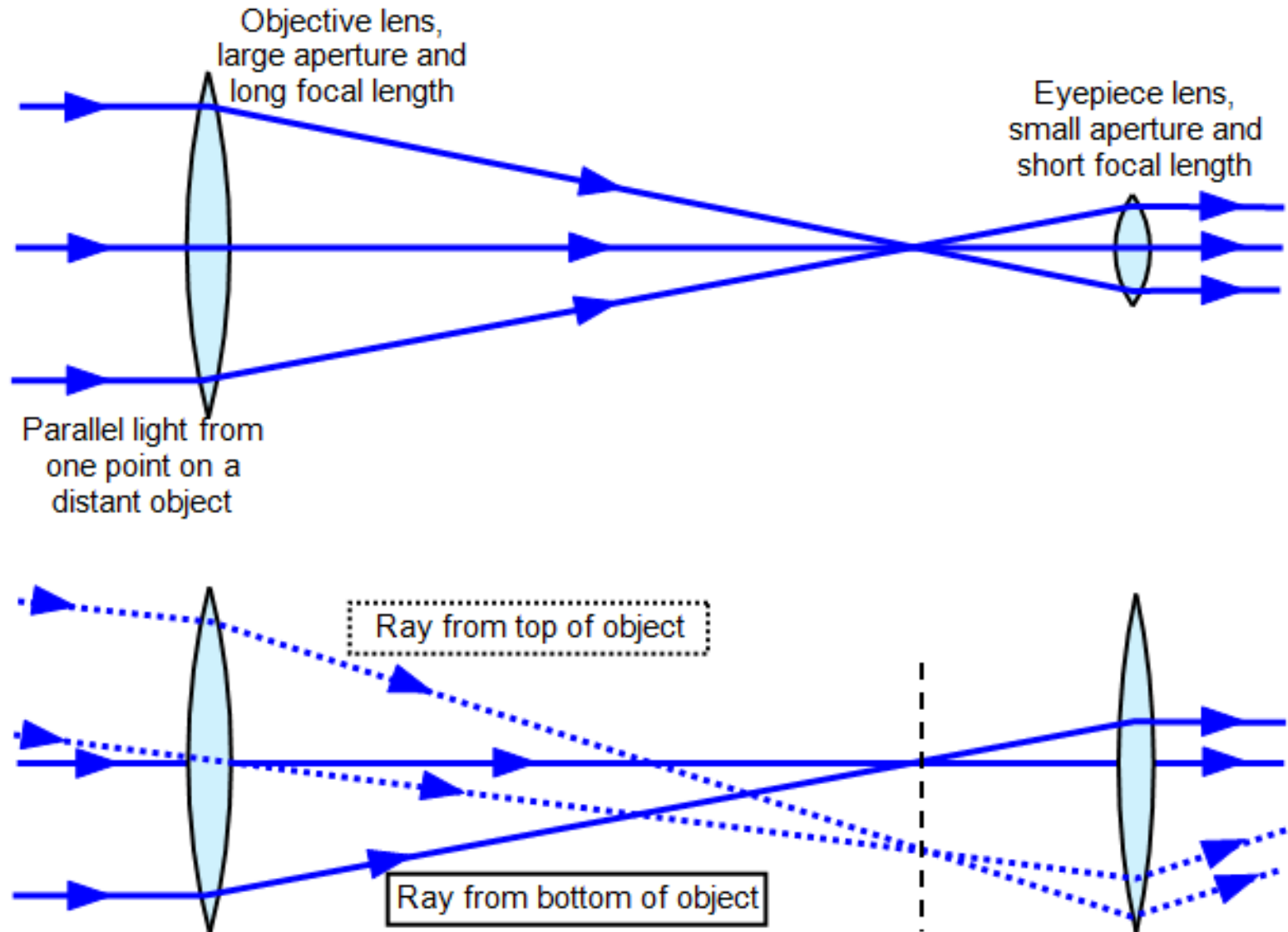

Notice that the image formed by this type of telescope is upside down.



# Angular Magnification through Eyepiece

- ◆ If you are viewing an object through a telescope, image size (or plate scale) is not a particularly useful measure.
- ◆ Instead, the measure of interest is angular magnification ( $M$ ), which is the ratio of the observed angular size ( $\alpha_{IM}$ ) to the actual angular size of the object ( $\alpha_{OB}$ )

$$M = \frac{\alpha_{IM}}{\alpha_{OB}} = \frac{f_o}{f_e} \quad (\text{for small angles } \alpha_{IM} \text{ and } \alpha_{OB})$$

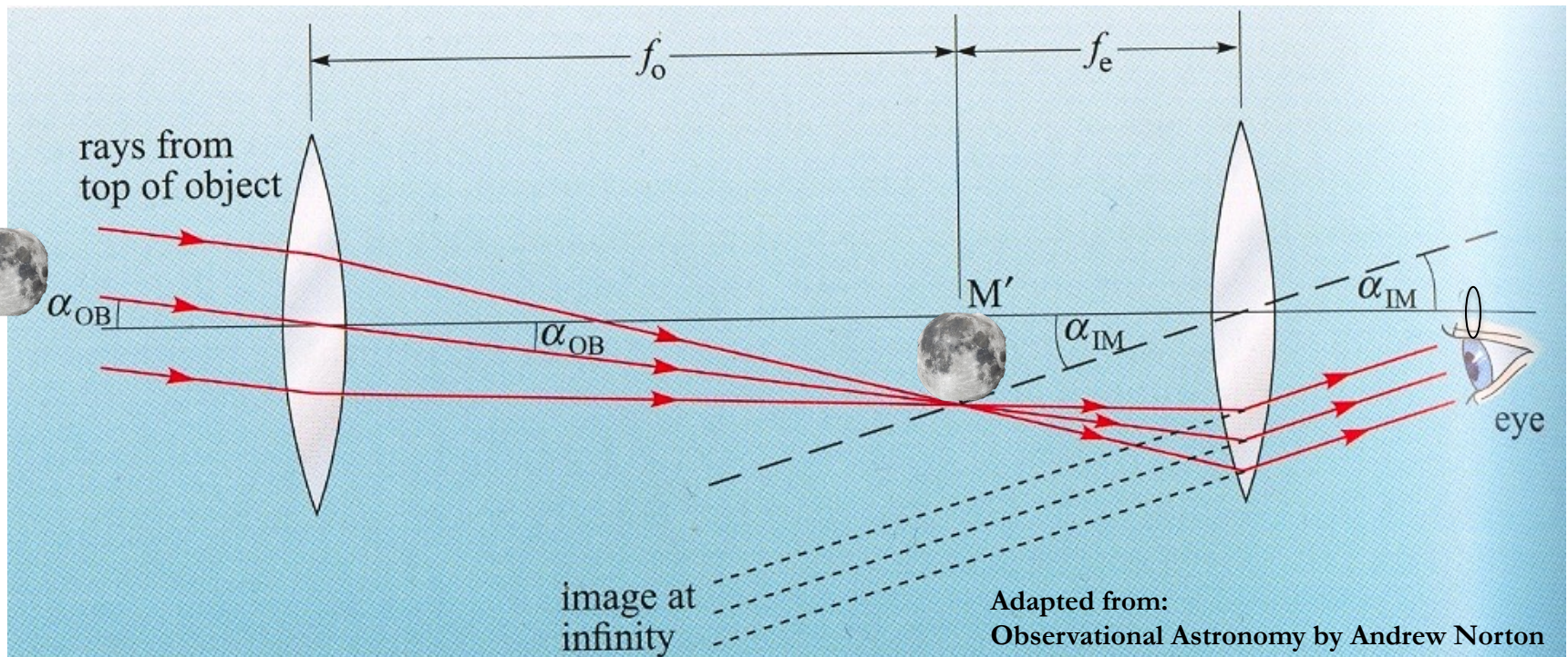

# Angular Magnification through Eyepiece

- ◆ Angular magnification ( $M$ ) is the ratio of the observed angular size ( $\alpha_{IM}$ ) to the actual angular size of the object ( $\alpha_{OB}$ )

$$M = \frac{\alpha_{IM}}{\alpha_{OB}} = \frac{f_o}{f_e}$$

(for small angles  $\alpha_{IM}$  and  $\alpha_{OB}$ )

- ◆ How to maximize angular magnification?

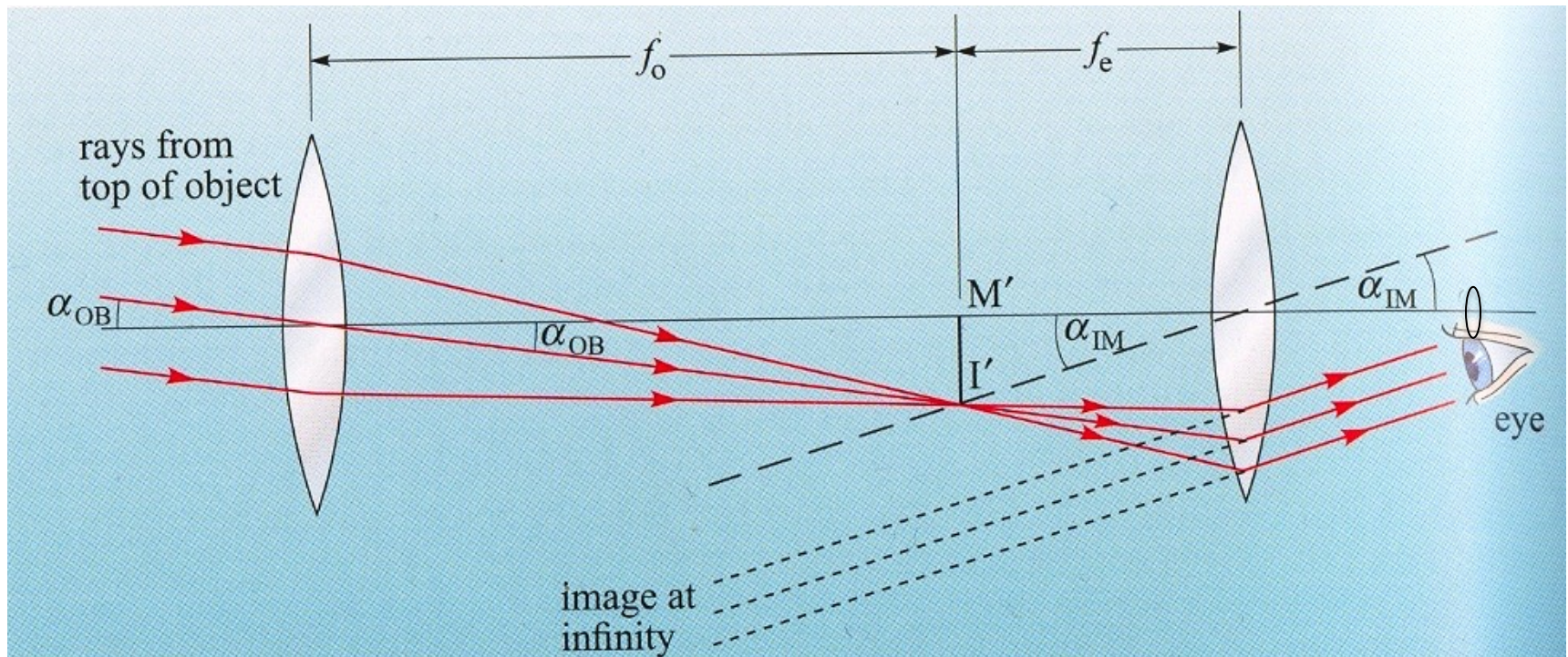

# Angular Magnification through Eyepiece

- ◆ Angular magnification ( $M$ ) is the ratio of the observed angular size ( $\alpha_{IM}$ ) to the actual angular size of the object ( $\alpha_{OB}$ )

$$M = \frac{\alpha_{IM}}{\alpha_{OB}} = \frac{f_o}{f_e} \quad (\text{for small angles } \alpha_{IM} \text{ and } \alpha_{OB})$$

- ◆ How to maximize angular magnification? Objective with long focal length, eyepiece with short focal length.



# Field of View at Eyepiece

---

- ◆ What property or properties determine the field of view of an eyepiece (of a given focal length)?

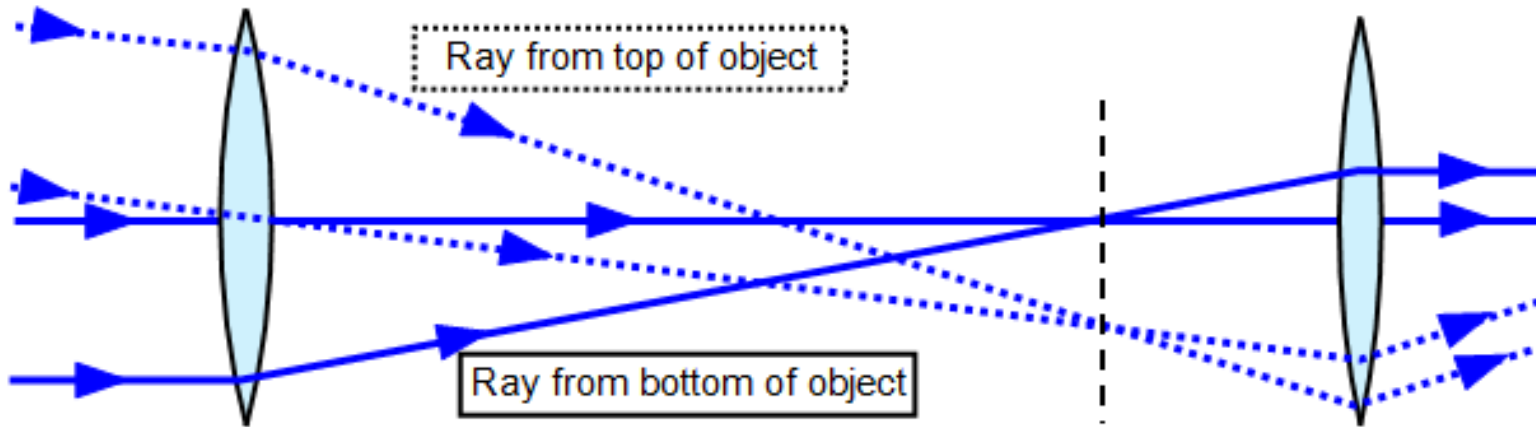

# Field of View at Eyepiece

---

- ◆ What property or properties determine the field of view of an eyepiece (of a given focal length)? **Diameter of eyepiece and ability to bend rays.**

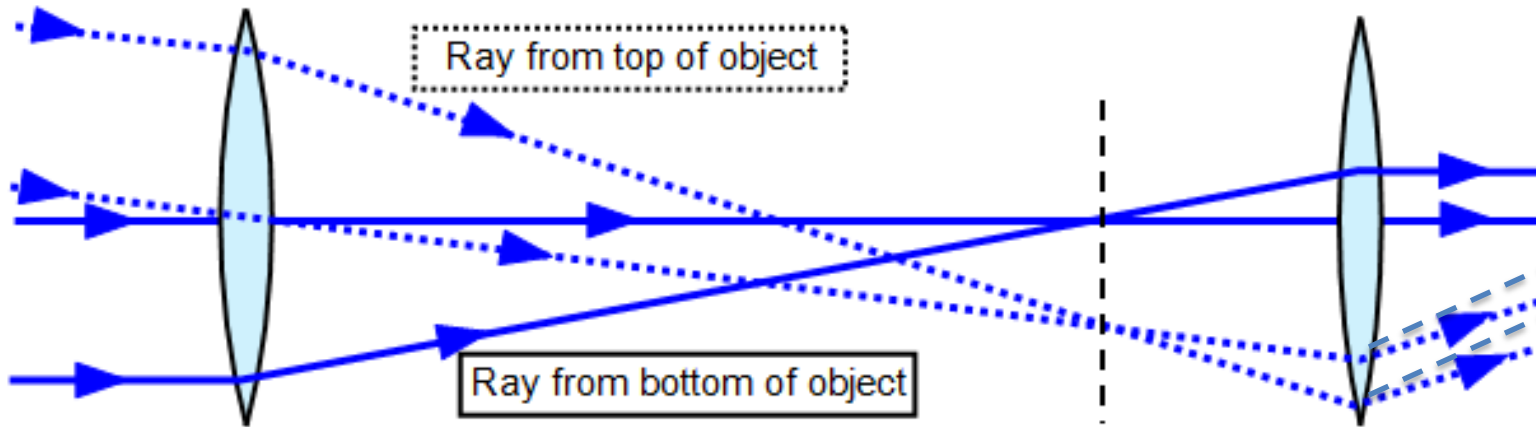

# Field of View at Eyepiece

- ◆ To avoid reduction in light intercepted by eyepiece at large angles to telescope axis, a field stop (diaphragm) is usually employed in the eyepiece.

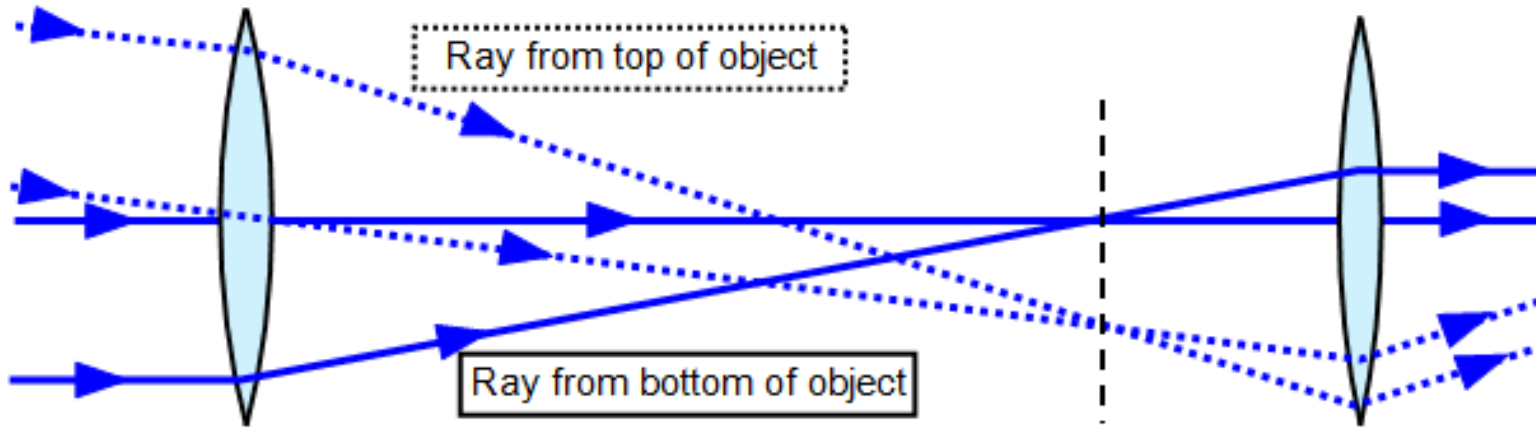

**Huygens Design**

**Ramsden Design**

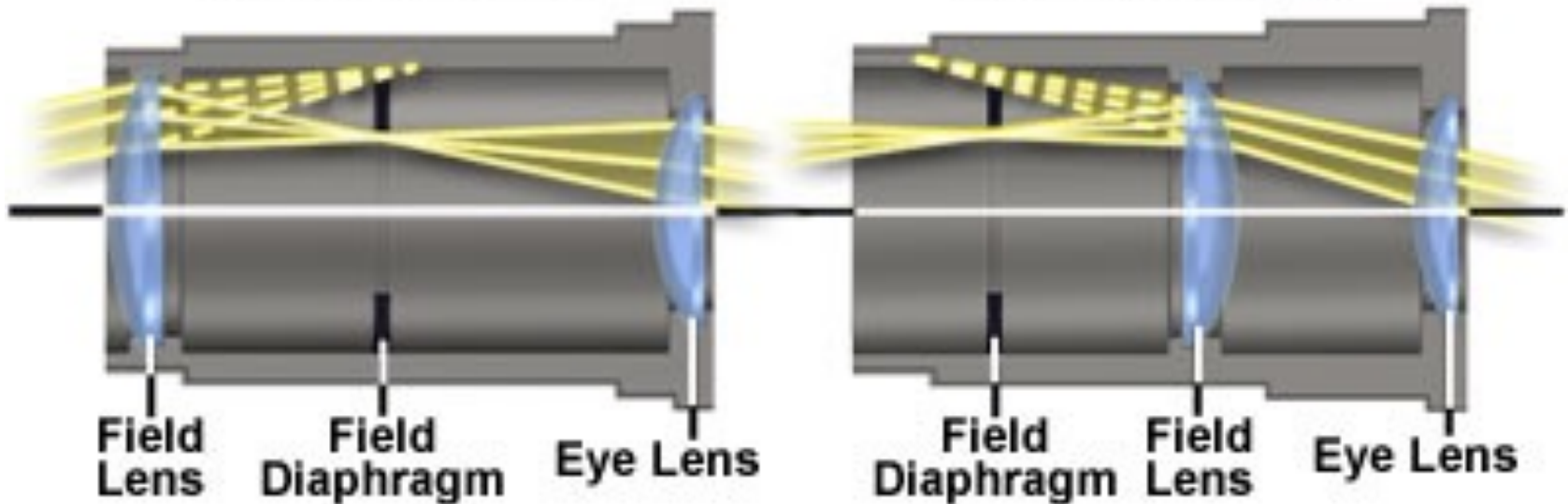

# Galilean Telescope

- ◆ Compare the Keplerian with the Galilean (refracting) telescope. The Galilean telescope uses a diverging instead of a converging eyepiece (not a Huygens eyepiece), with the focus of the objective lying behind the eyepiece. The Galilean telescope produces an upright image.

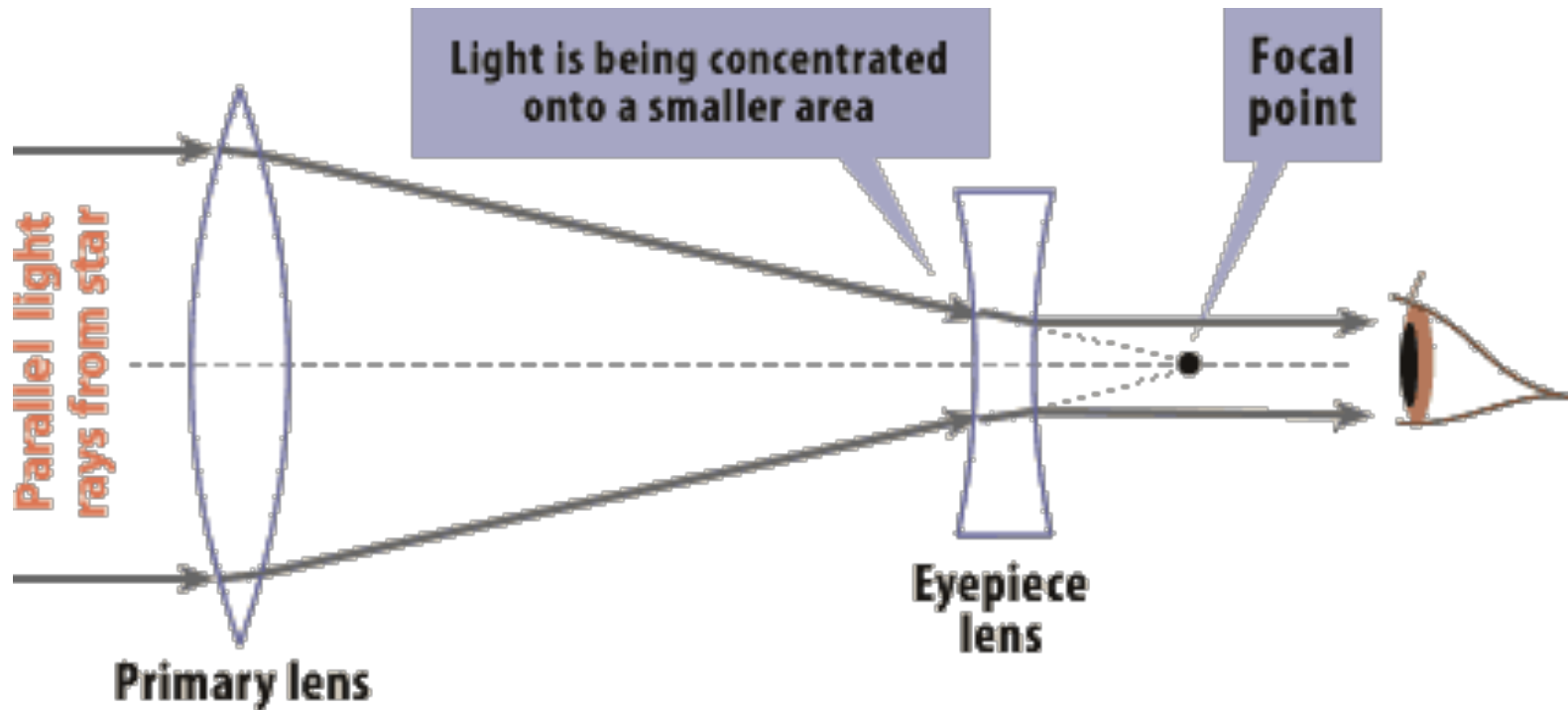

This **convex** spherical lens (called the primary lens) collected and concentrated the light ...

... and this **concave** eyepiece lens made the concentrated light rays parallel again.

# Galilean Telescope

- ◆ Compare the Keplerian with the Galilean (refracting) telescope. The Galilean telescope uses a diverging instead of a converging eyepiece (not a Huygens eyepiece), with the focus of the objective lying behind the eyepiece. The Galilean telescope produces an upright image. **What is the disadvantage of the Galilean versus the Keplerian telescope?**

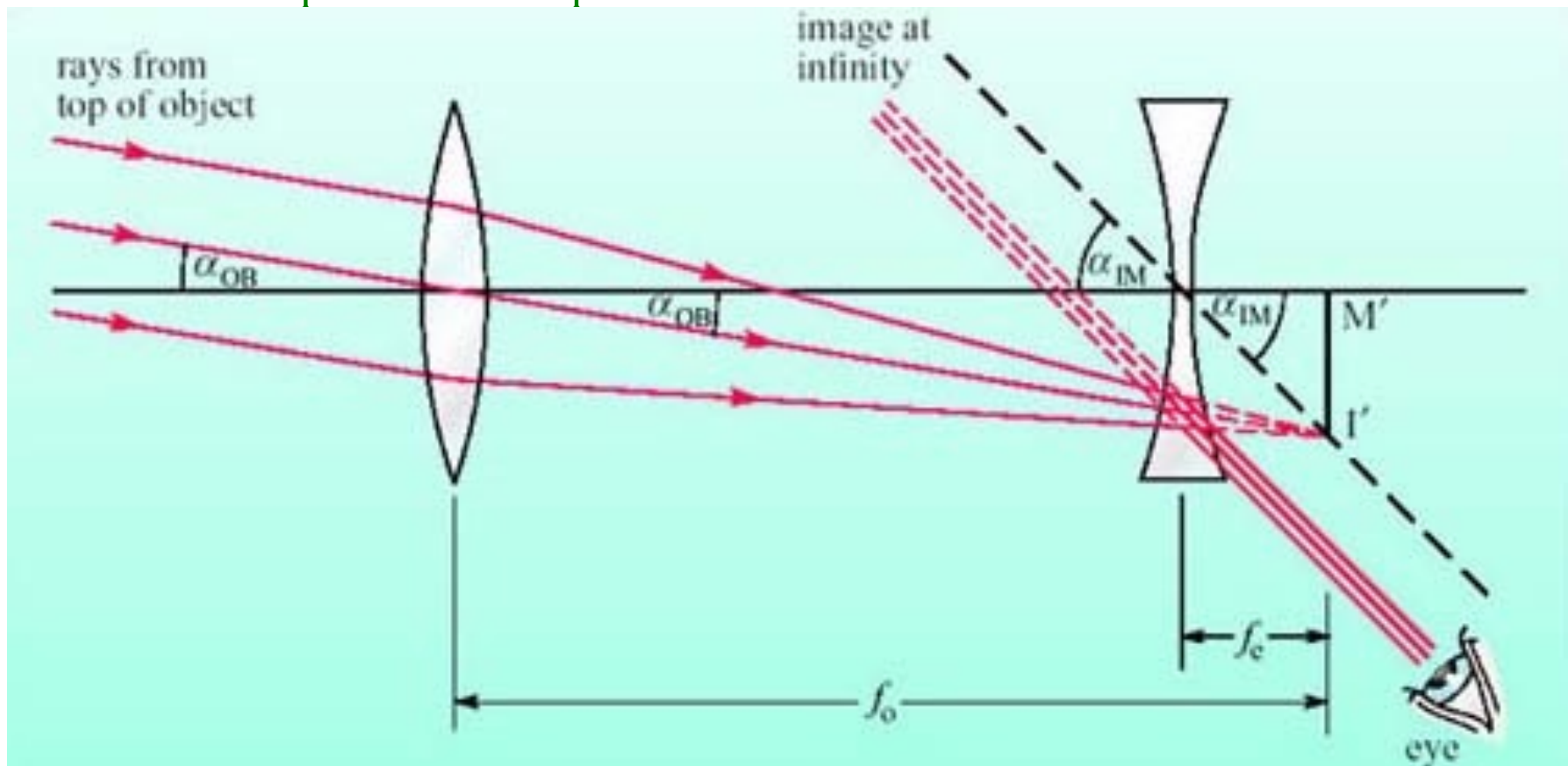



# Galilean Telescope

- ◆ Compare the Keplerian with the Galilean (refracting) telescope. The Galilean telescope uses a diverging instead of a converging eyepiece (not a Huygens eyepiece), with the focus of the objective lying behind the eyepiece. The Galilean telescope produces an upright image. **What is the disadvantage of the Galilean versus the Keplerian telescope? Smaller field of view.**

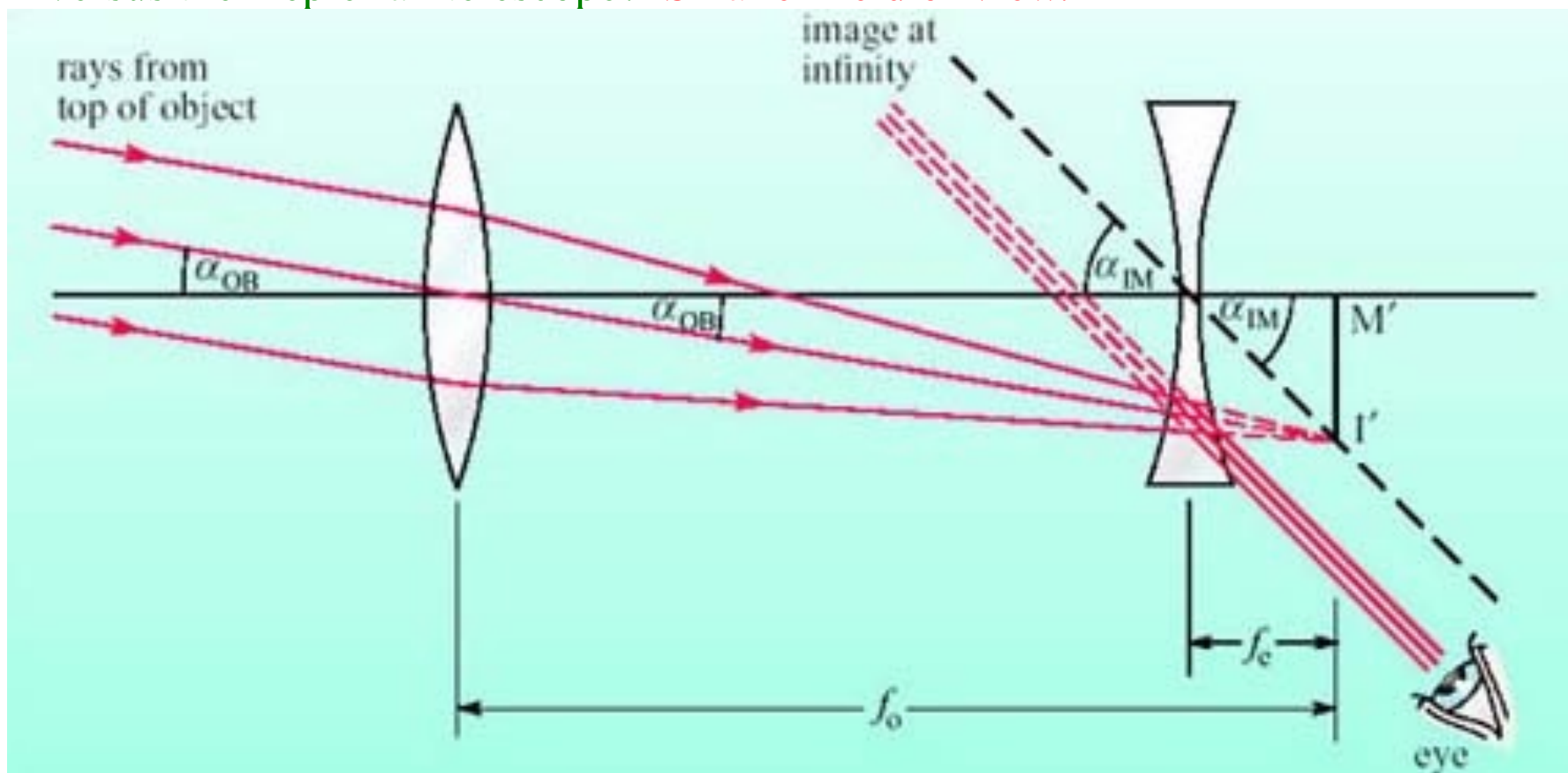

# Field of View at Eyepiece

- ◆ The field of view of the eyepiece therefore determines the apparent field (of view) when looking through a telescope.
- ◆ How is the true field related to the apparent field?

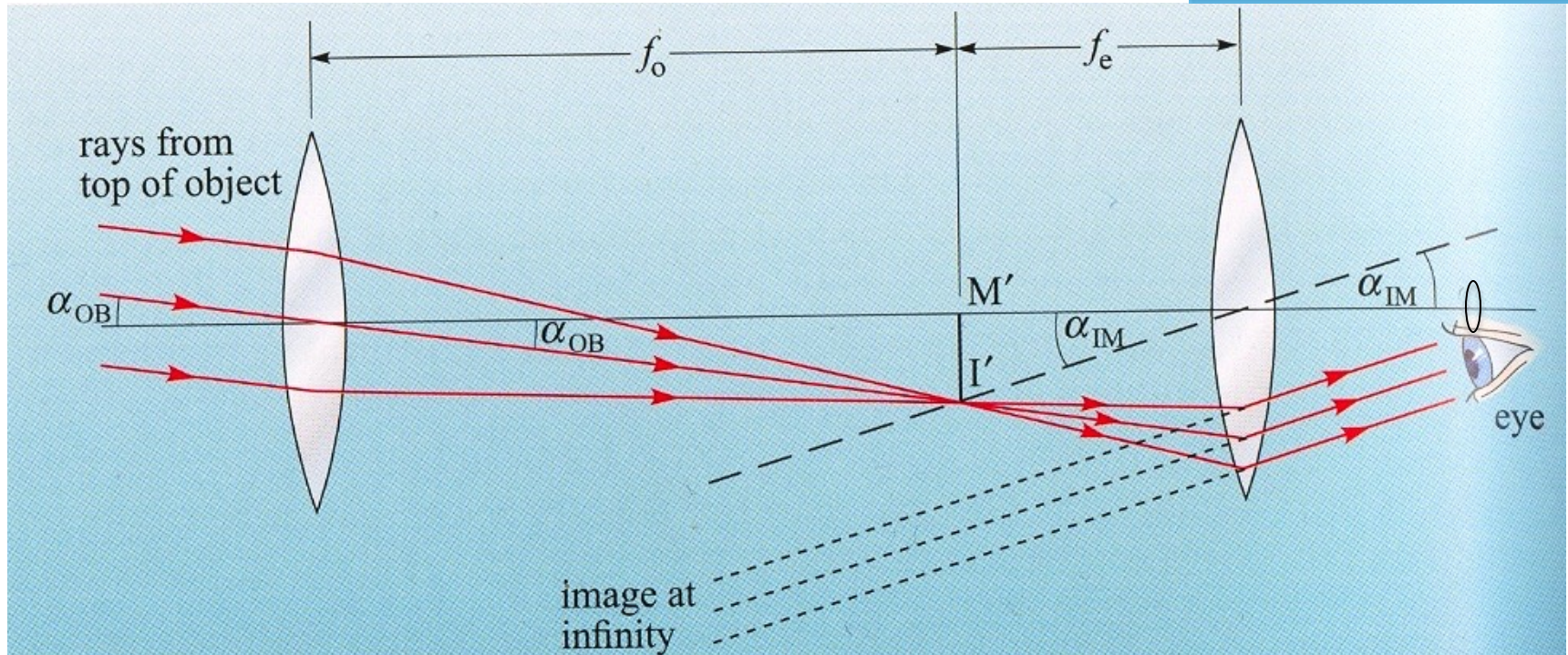
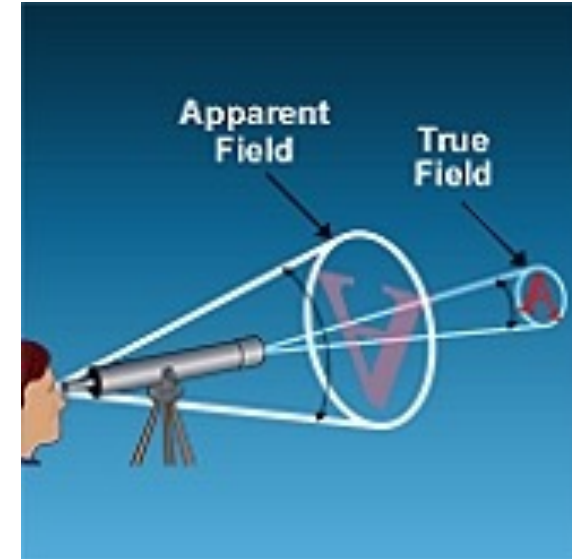

# Field of View at Eyepiece

- ◆ The field of view of the eyepiece therefore determines the apparent field (of view) when looking through a telescope.
- ◆ How is the true field related to the apparent field?

$$\text{True Field} = \frac{\text{Apparent Field}}{\text{Magnification}}$$

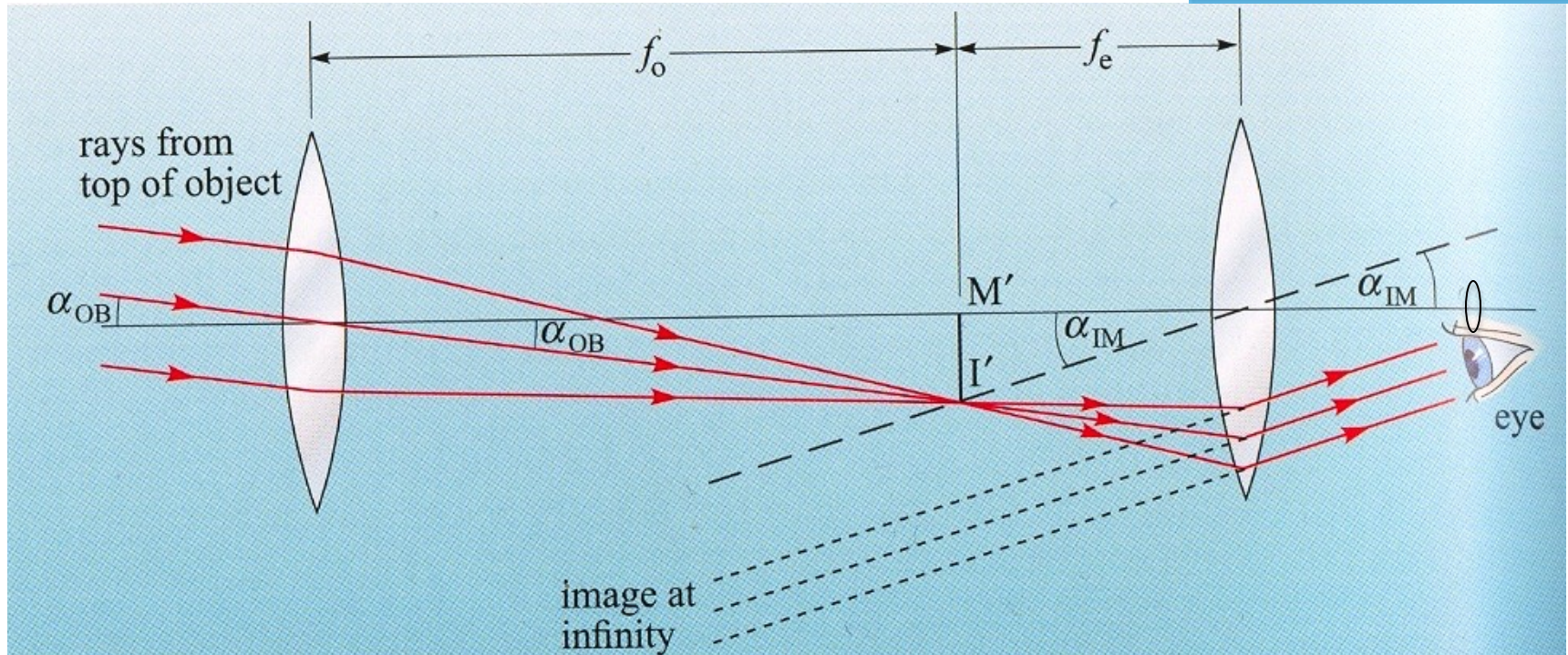
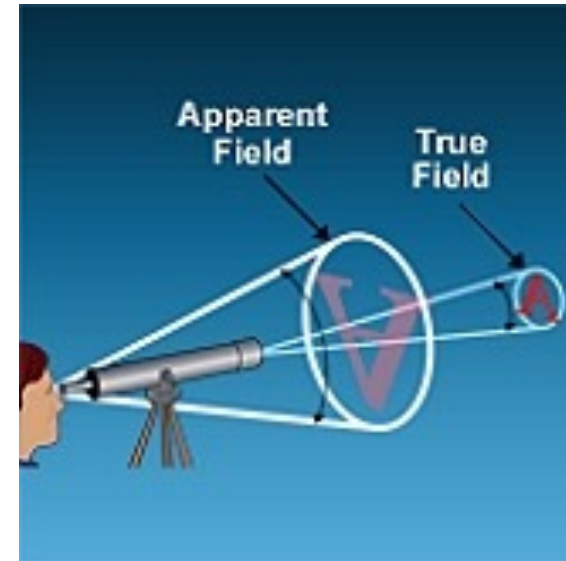

# Field of View at Eyepiece

- ◆ Do telescopes with shorter or longer focal lengths provide larger true fields with a given eyepiece?

$$\text{True Field} = \frac{\text{Apparent Field}}{\text{Magnification}}$$

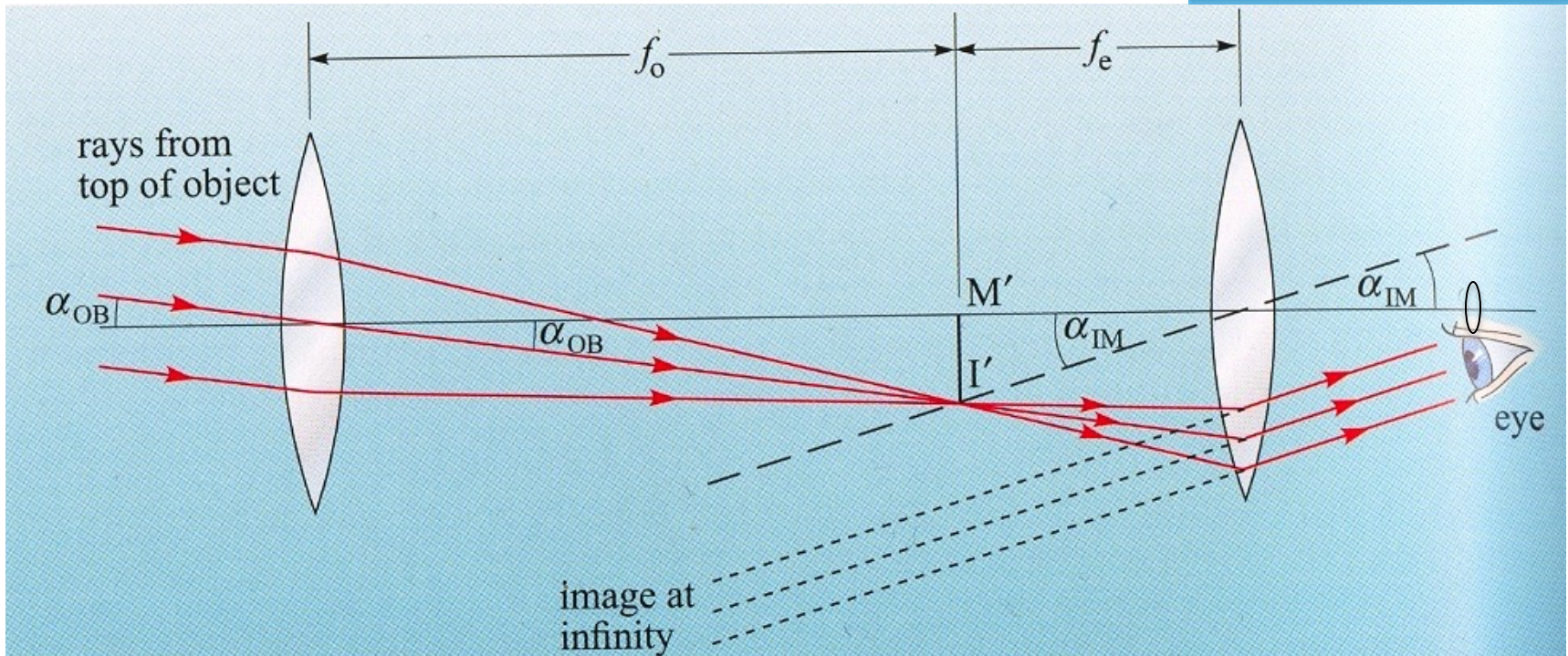
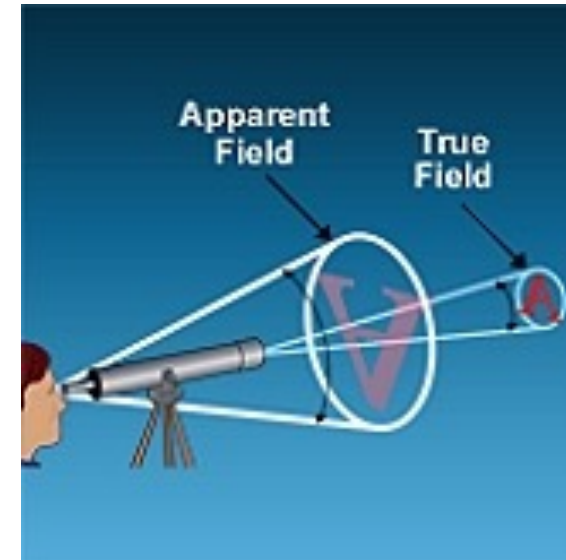

# Field of View at Eyepiece

- ◆ Do telescopes with shorter or longer focal lengths provide larger true fields with a given eyepiece? **Shorter focal lengths, hence lower magnifications.**

$$M = \frac{\alpha_{IM}}{\alpha_{OB}} = \frac{f_o}{f_e}$$

True Field =  
Apparent Field / Magnification

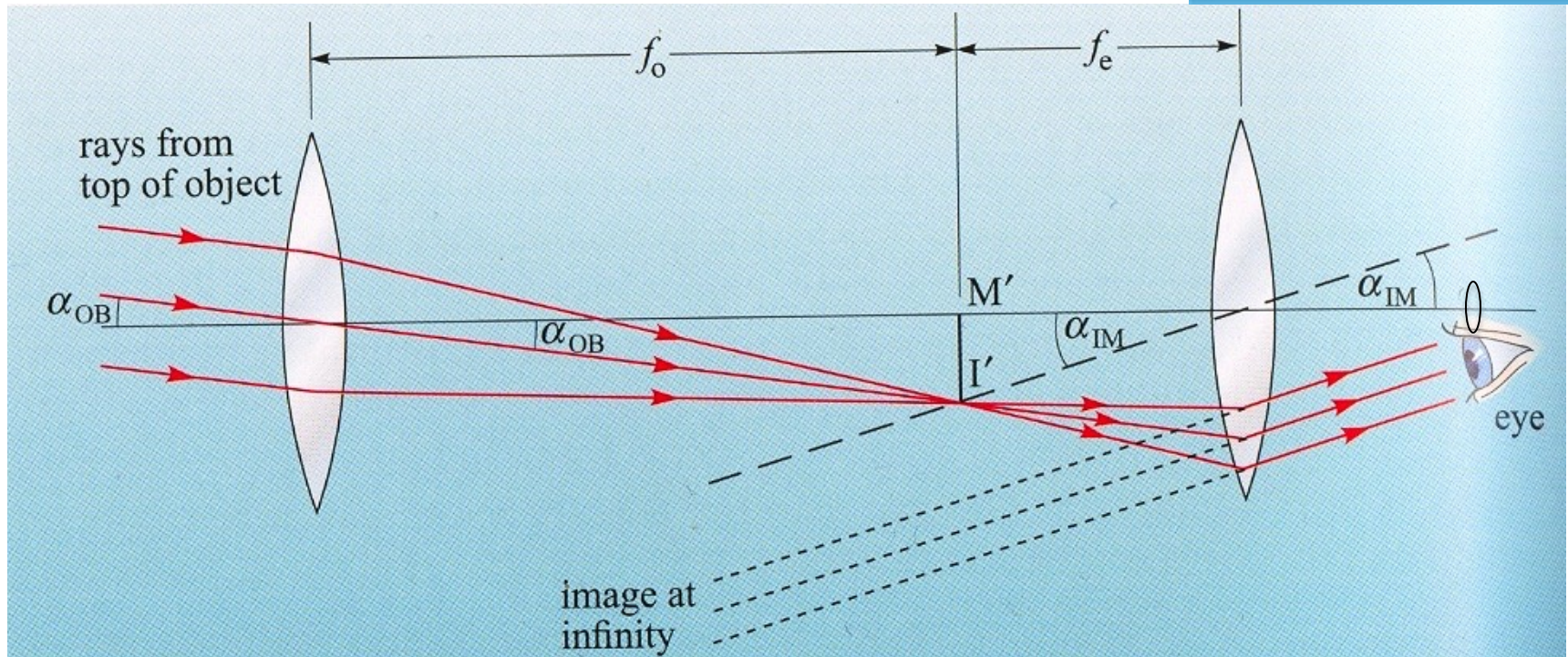
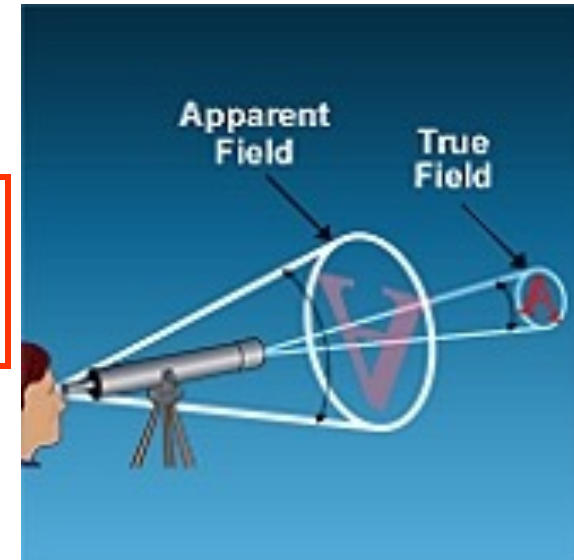

# Field of View at Eyepiece

- ◆ Do eyepieces (of a given field of view) with shorter or longer focal lengths provide larger true fields with a given telescope?

$$\text{True Field} = \frac{\text{Apparent Field}}{\text{Magnification}}$$

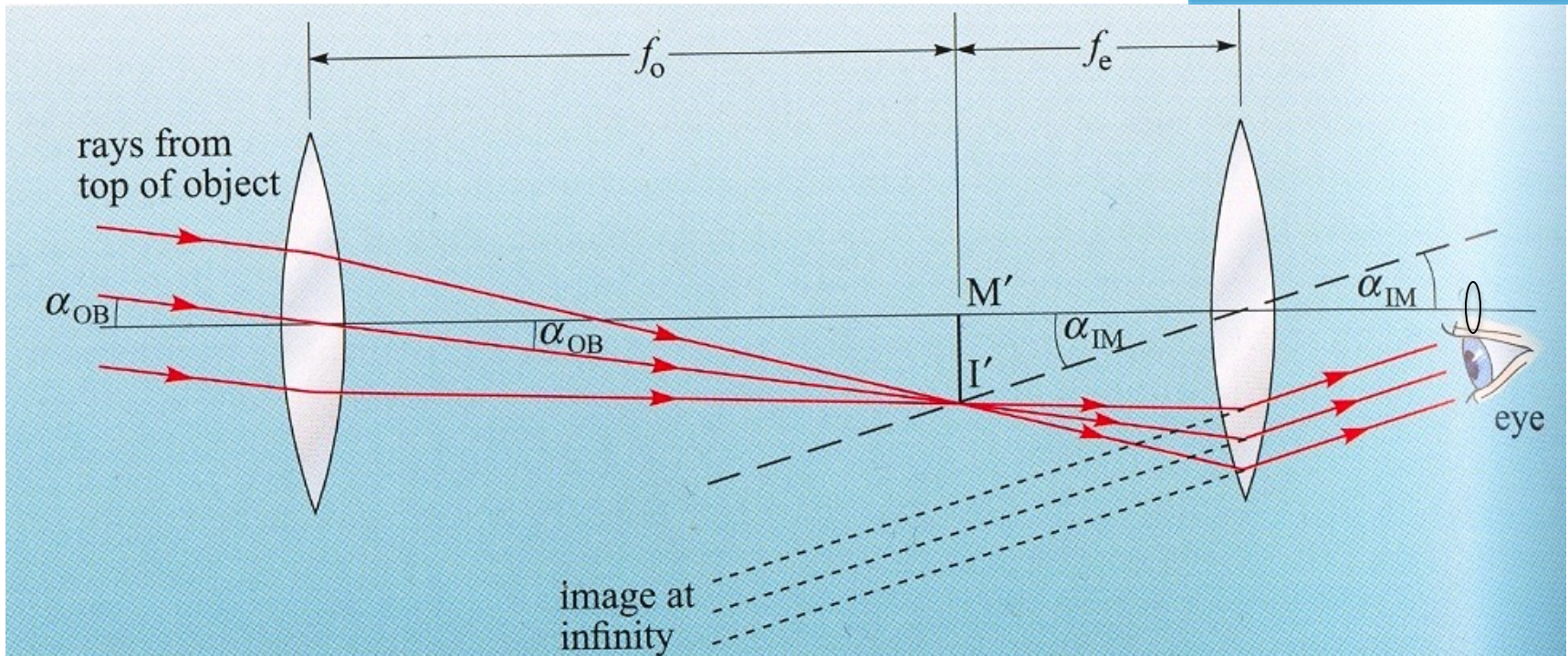
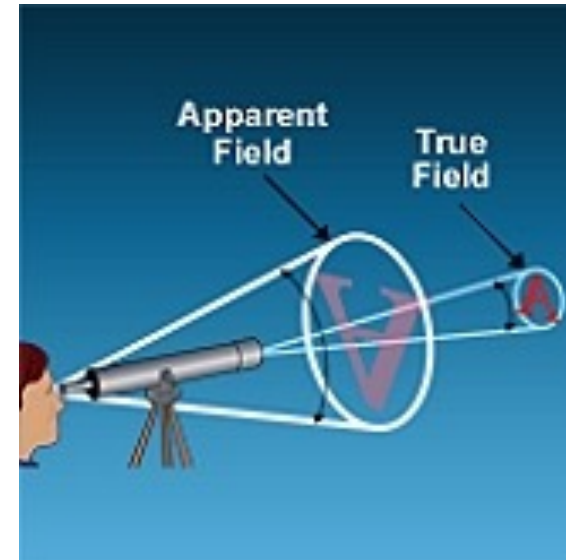

# Field of View at Eyepiece

- Do eyepieces (of a given field of view) with shorter or longer focal lengths provide larger true fields with a given telescope? Longer focal lengths, hence lower magnifications.

$$M = \frac{\alpha_{IM}}{\alpha_{OB}} = \frac{f_o}{f_e}$$

True Field =  
Apparent Field / Magnification

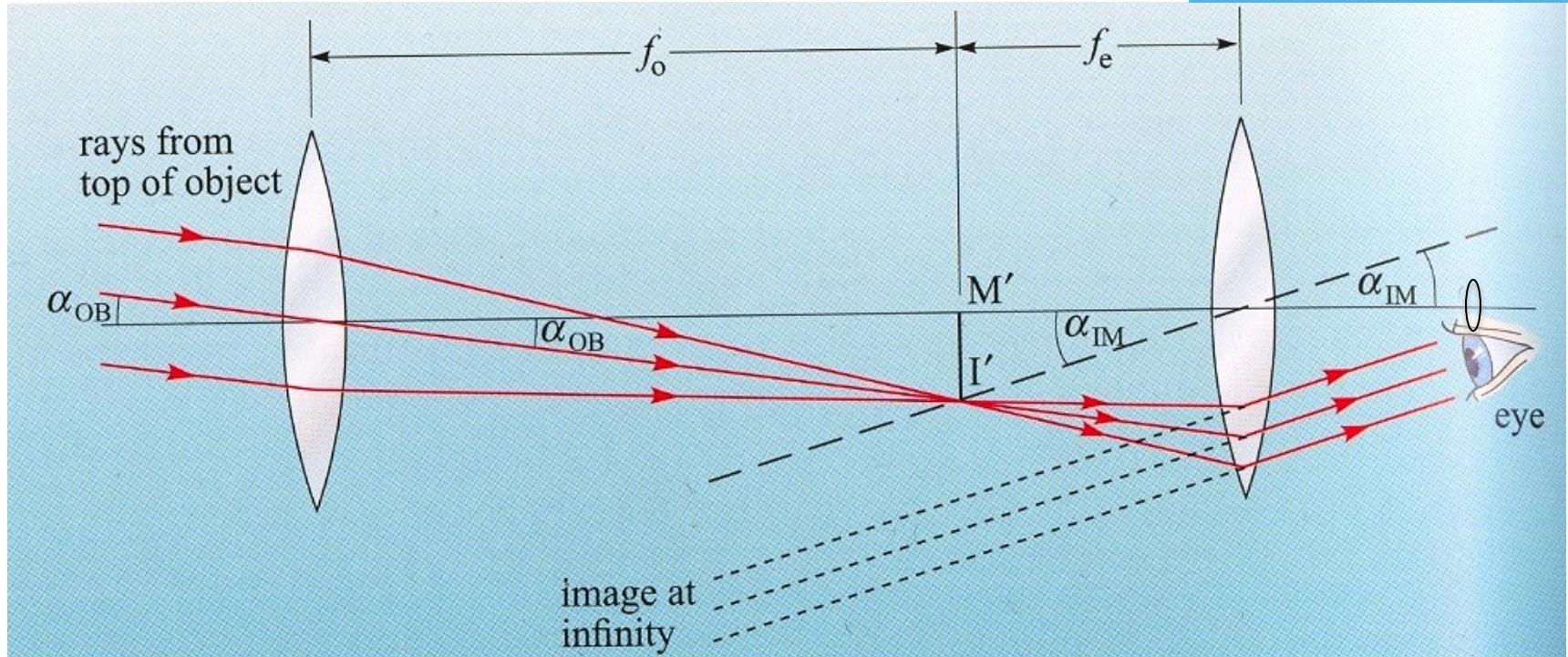
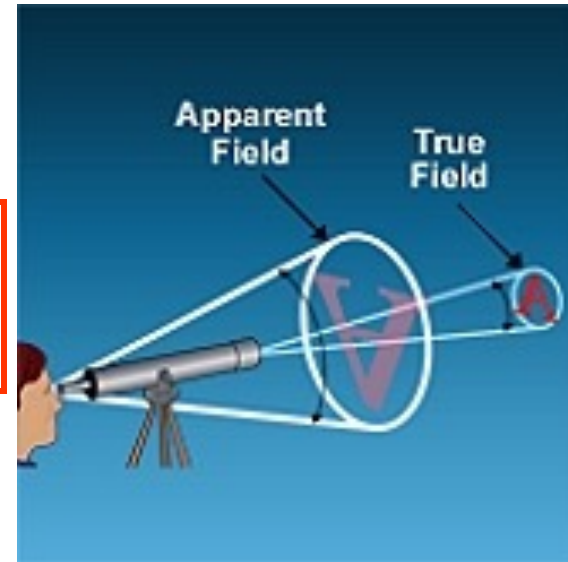

# Exit Pupil

- ◆ Is it guaranteed that all the light that passes through the eyepiece (i.e., field of view of the eyepiece, or apparent field) is collected by the eye?

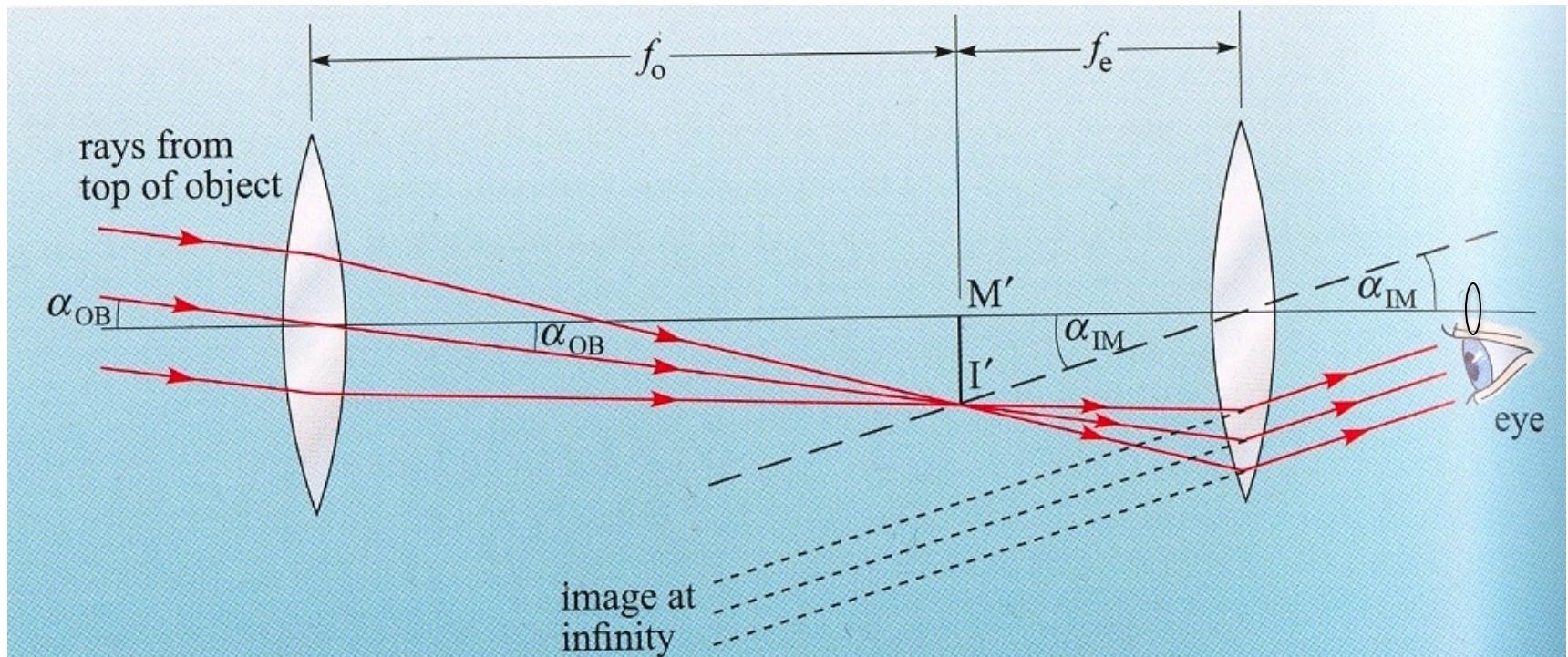



# Exit Pupil

- ◆ Is it guaranteed that all the light that passes through the eyepiece (i.e., field of view of the eyepiece, or apparent field) is collected by the eye? **No, depends on eye pupil size and where you place your eye with respect to the eyepiece. Thus, the apparent, and hence true, field of view depends on the size and location of the eye pupil.**

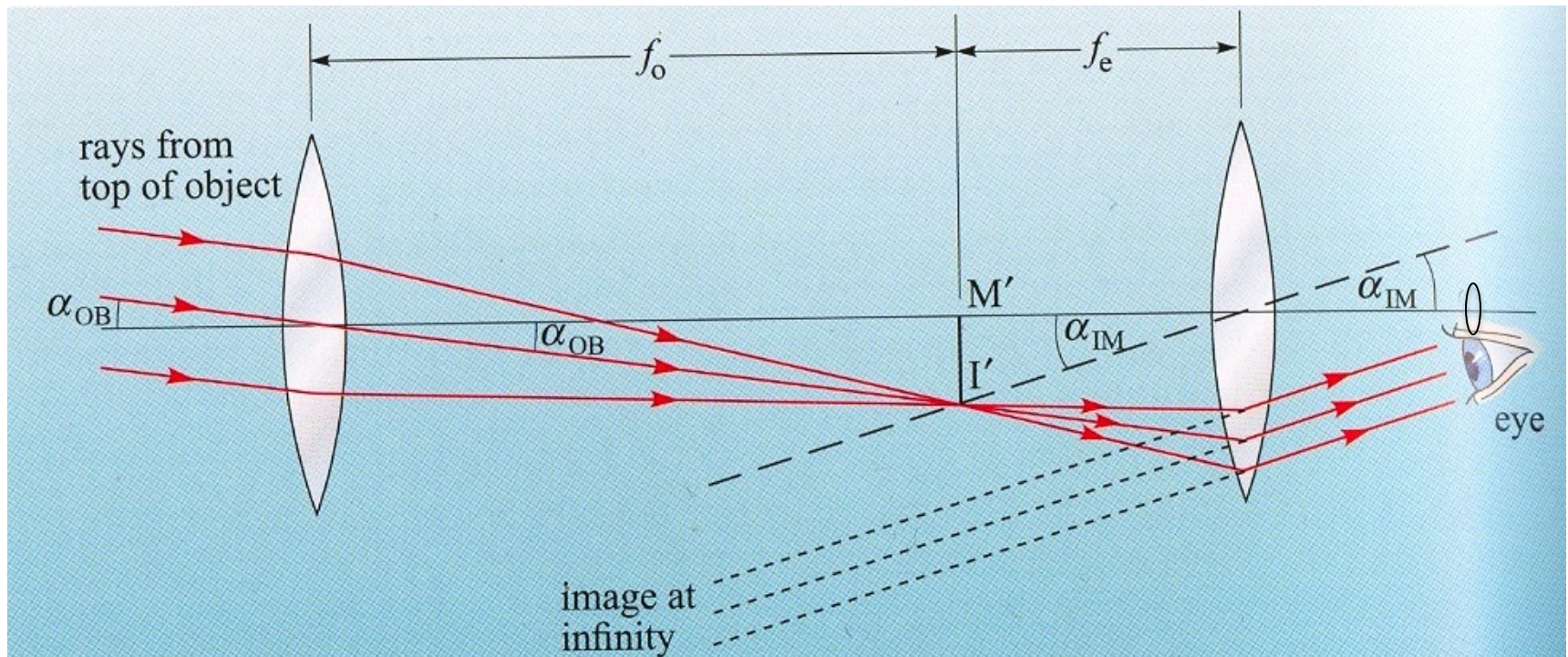

# Exit Pupil

- ◆ Is it guaranteed that all the light that passes through the eyepiece (i.e., field of view of the eyepiece, or apparent field) is collected by the eye? **No, depends on eye pupil size and where you place your eye with respect to the eyepiece. Thus, the apparent, and hence true, field of view depends on the size and location of the eye pupil.**
- ◆ For a larger maximum  $\alpha_{IM}$  and hence  $\alpha_{OB}$ , should you place your eye closer or further from the eyepiece?

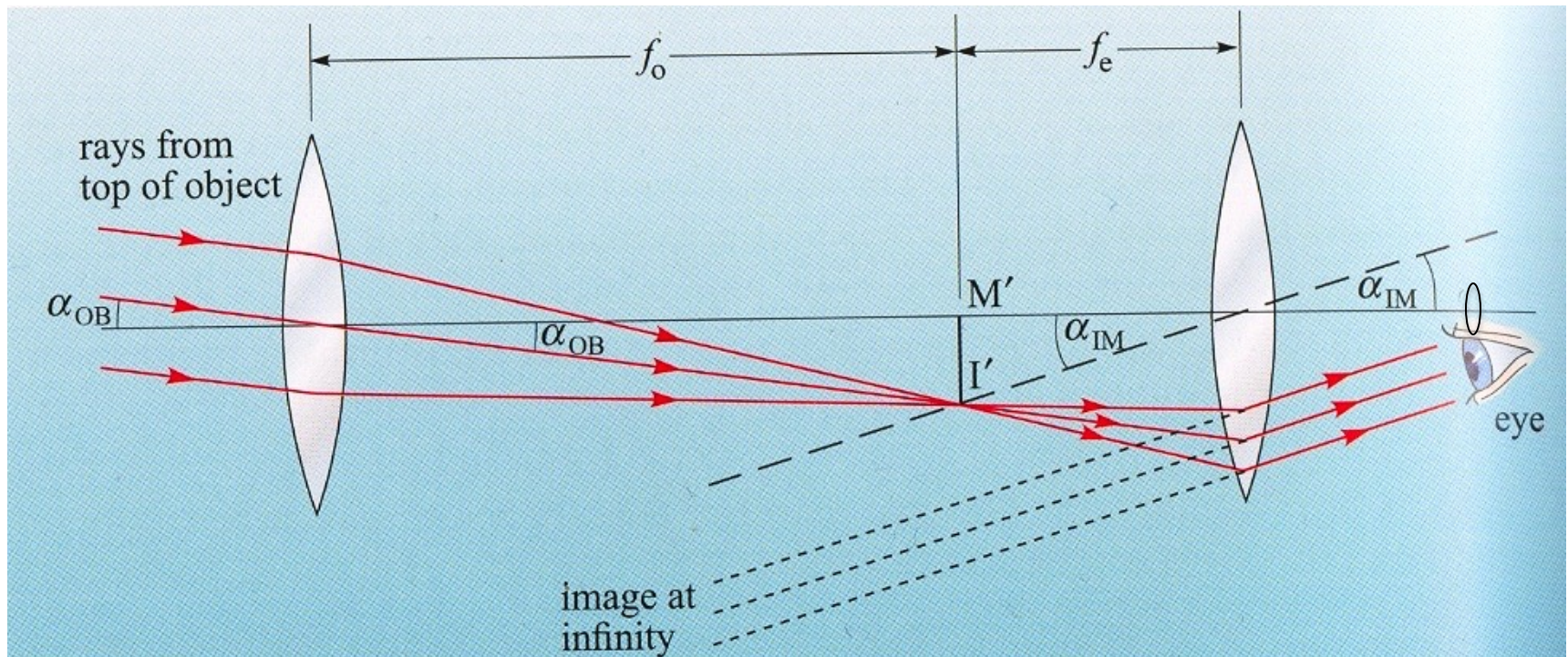

# Exit Pupil

- ◆ Is it guaranteed that all the light that passes through the eyepiece (i.e., field of view of the eyepiece, or apparent field) is collected by the eye? **No, depends on eye pupil size and where you place your eye with respect to the eyepiece. Thus, the apparent, and hence true, field of view depends on the size and location of the eye pupil.**
- ◆ For a larger maximum  $\alpha_{IM}$  and hence  $\alpha_{OB}$ , should you place your eye closer or further from the eyepiece? **Further from the eyepiece (but not too far!), but may not collect all light.**

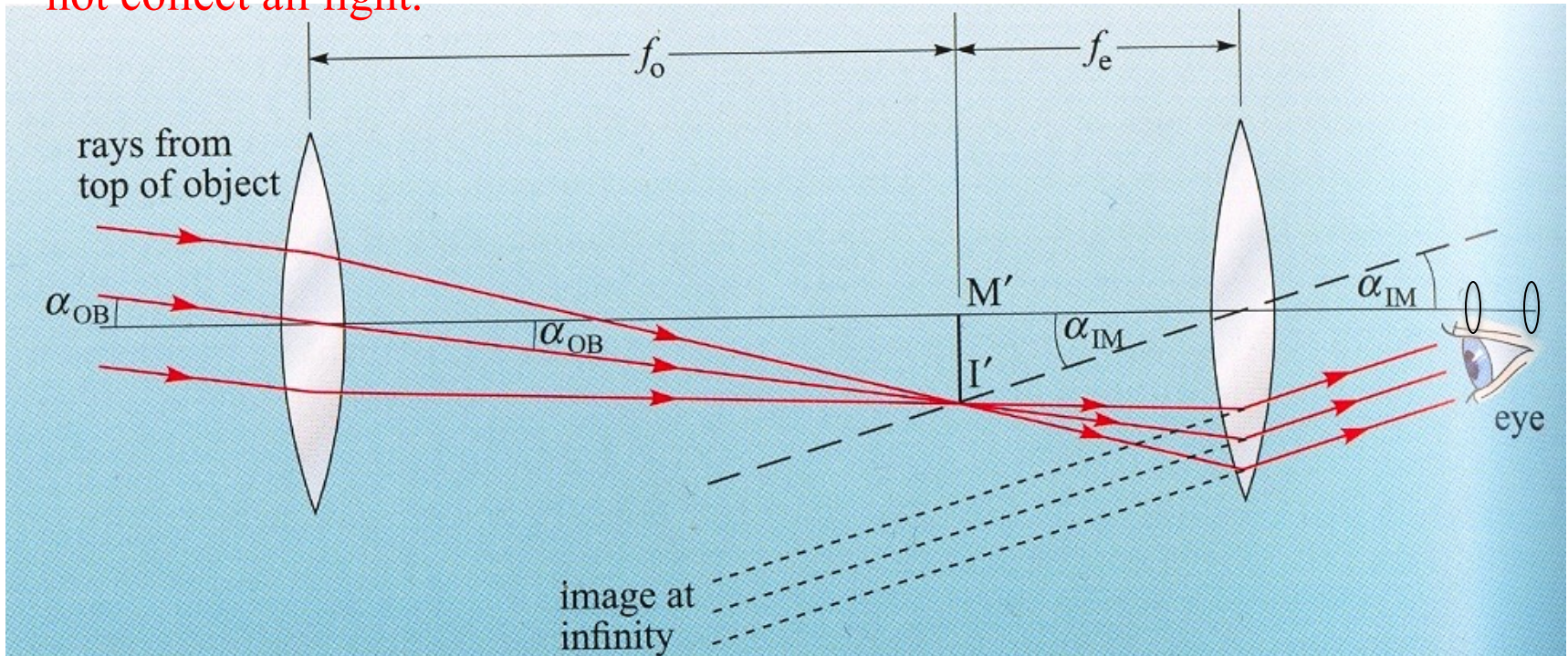

# Learning Objectives

---

## ◆ Optical Aberrations:

- field curvature
- spherical aberration
- coma
- astigmatism
- distortion
- chromatic aberration

## ◆ Telescope Configurations:

- refractors
- reflectors (Prime, Newtonian, Cassegrain, Coudé or Nasmyth, Schmidt, Schmidt-Cassegrain, Maksutov-Cassegrain)

## ◆ Telescope Mounts:

- equatorial
- altazimuth

## ◆ Telescope Dome and Observatory Site

# Thin Lens Approximation

- ◆ Recall that the thin lens formula (for lenses with spherical surfaces,  $R_1 = R_2$ )

$$\frac{1}{o} + \frac{1}{i} = \frac{1}{f}$$

assumes

-  $d \ll R_1, R_2$

- ◆ In this formulation, we ignore the thickness of the lens and treat the refraction of light through the lens as if a light ray bends in the plane of the lens (i.e., that the lens is infinitely thin).

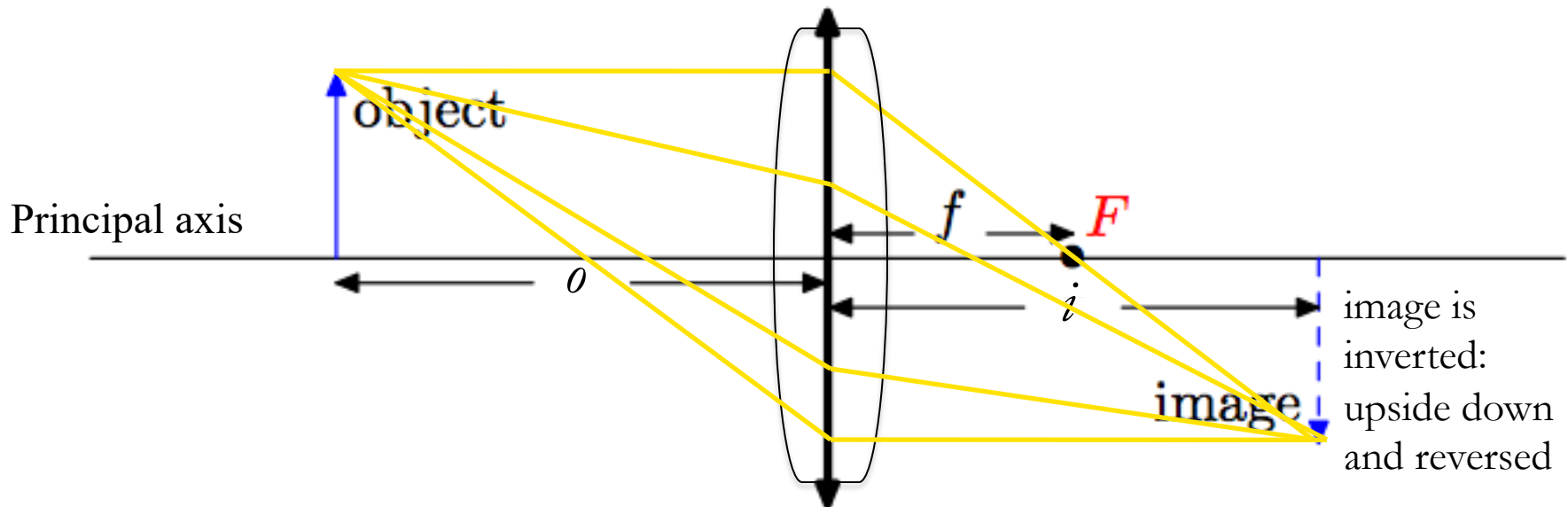

# Thin Lens Approximation

---

- ◆ Recall that the thin lens formula (for lenses with spherical surfaces,  $R_1 = R_2$ )

$$\boxed{\frac{1}{o} + \frac{1}{i} = \frac{1}{f}}$$

assumes

-  $d \ll R_1, R_2$

- ◆ In this formulation, we ignore the thickness of the lens and treat the refraction of light through the lens as if a light ray bends in the plane of the lens (i.e., that the lens is infinitely thin).

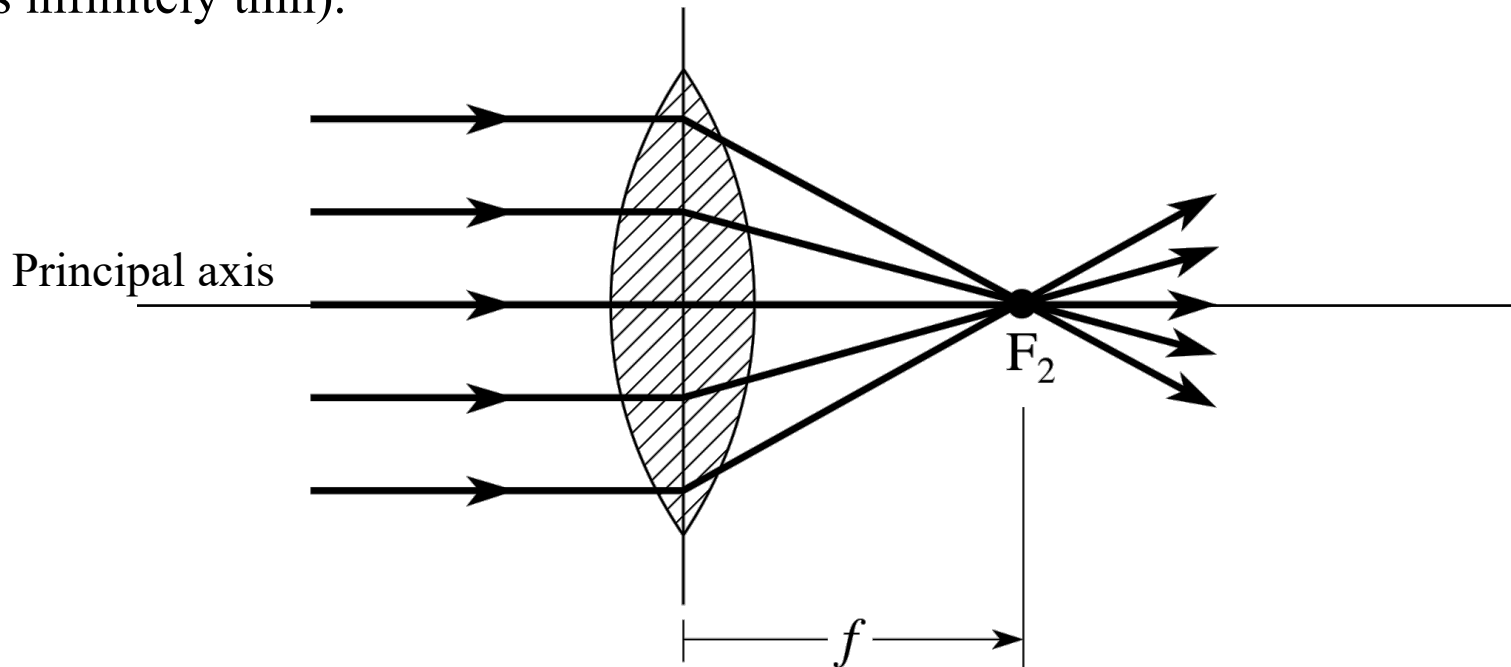

# Thin Lens Approximation

- ◆ Recall that the thin lens formula (for lenses with spherical surfaces,  $R_1 = R_2$ )

$$\frac{1}{o} + \frac{1}{i} = \frac{1}{f}$$

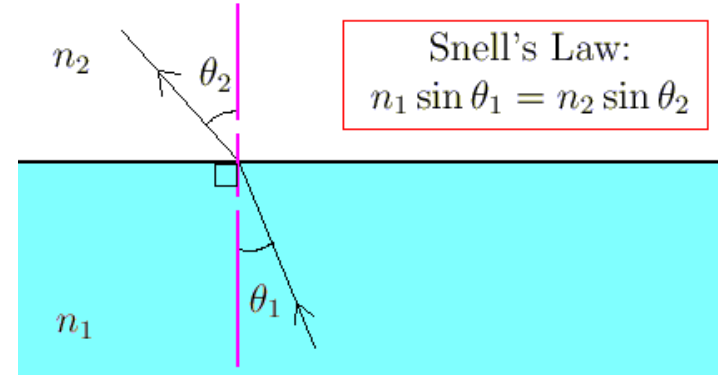

- ◆ In reality, what actually happens?

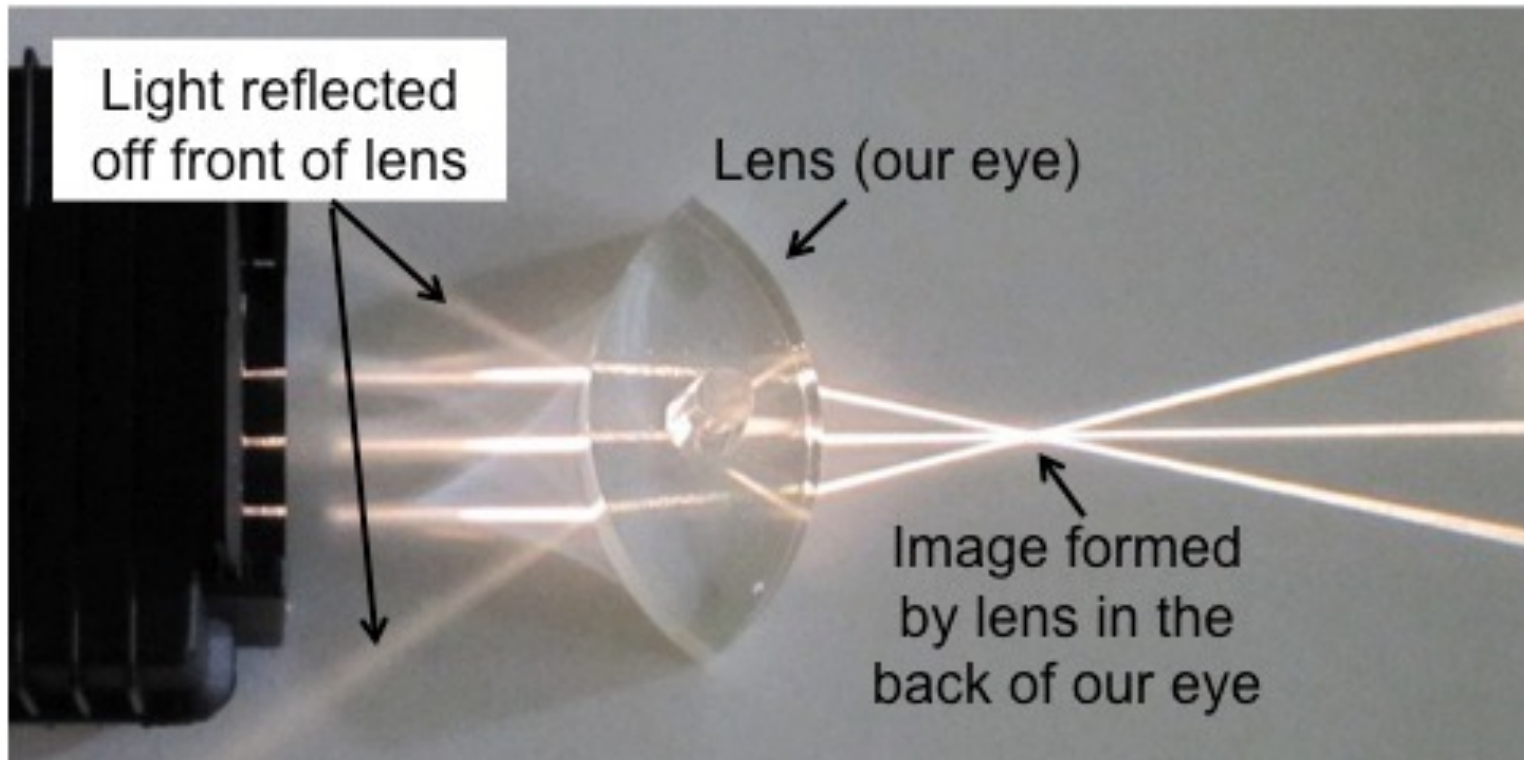

# Thin Lens Approximation

- ◆ Recall that the thin lens formula (for lenses with spherical surfaces,  $R_1 = R_2$ )

$$\frac{1}{o} + \frac{1}{i} = \frac{1}{f}$$

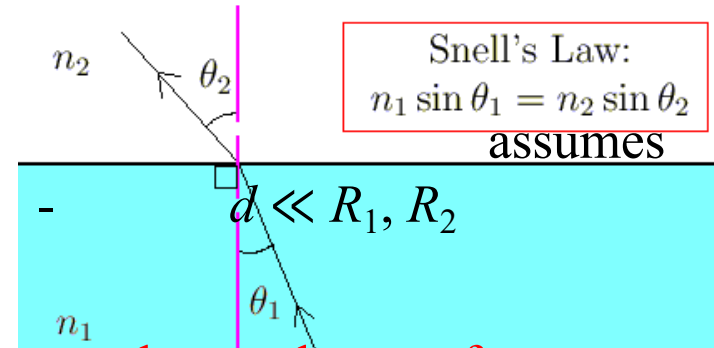

- ◆ In reality, what actually happens? Refraction occurs at the two lens surfaces.

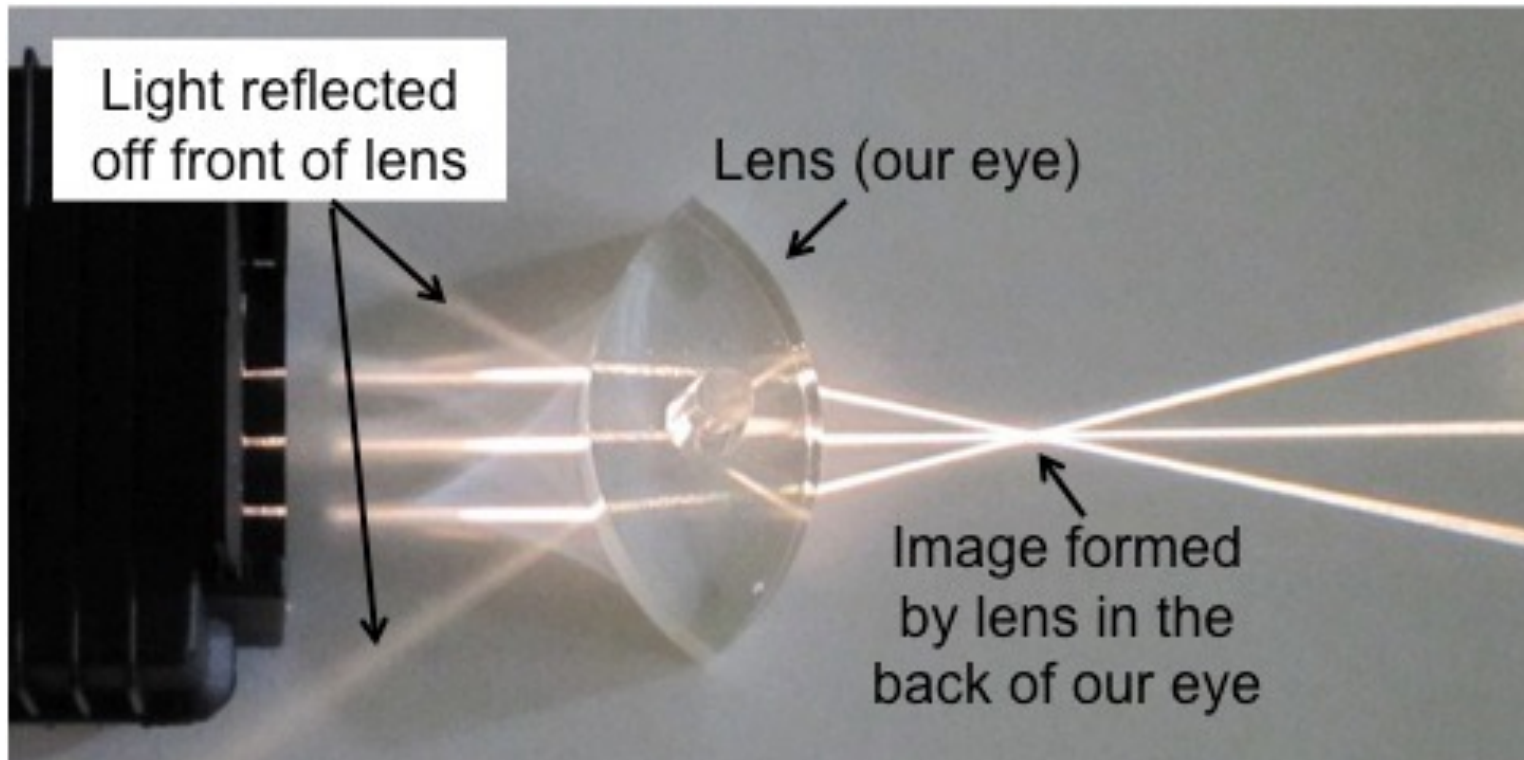



# Thin Lens Approximation

- ◆ Recall that the thin lens formula (for lenses with spherical surfaces,  $R_1 = R_2$ )

$$\frac{1}{o} + \frac{1}{i} = \frac{1}{f}$$

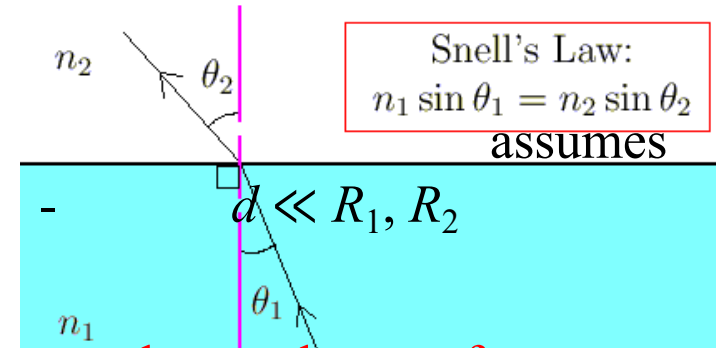

- ◆ In reality, what actually happens? Refraction occurs at the two lens surfaces.

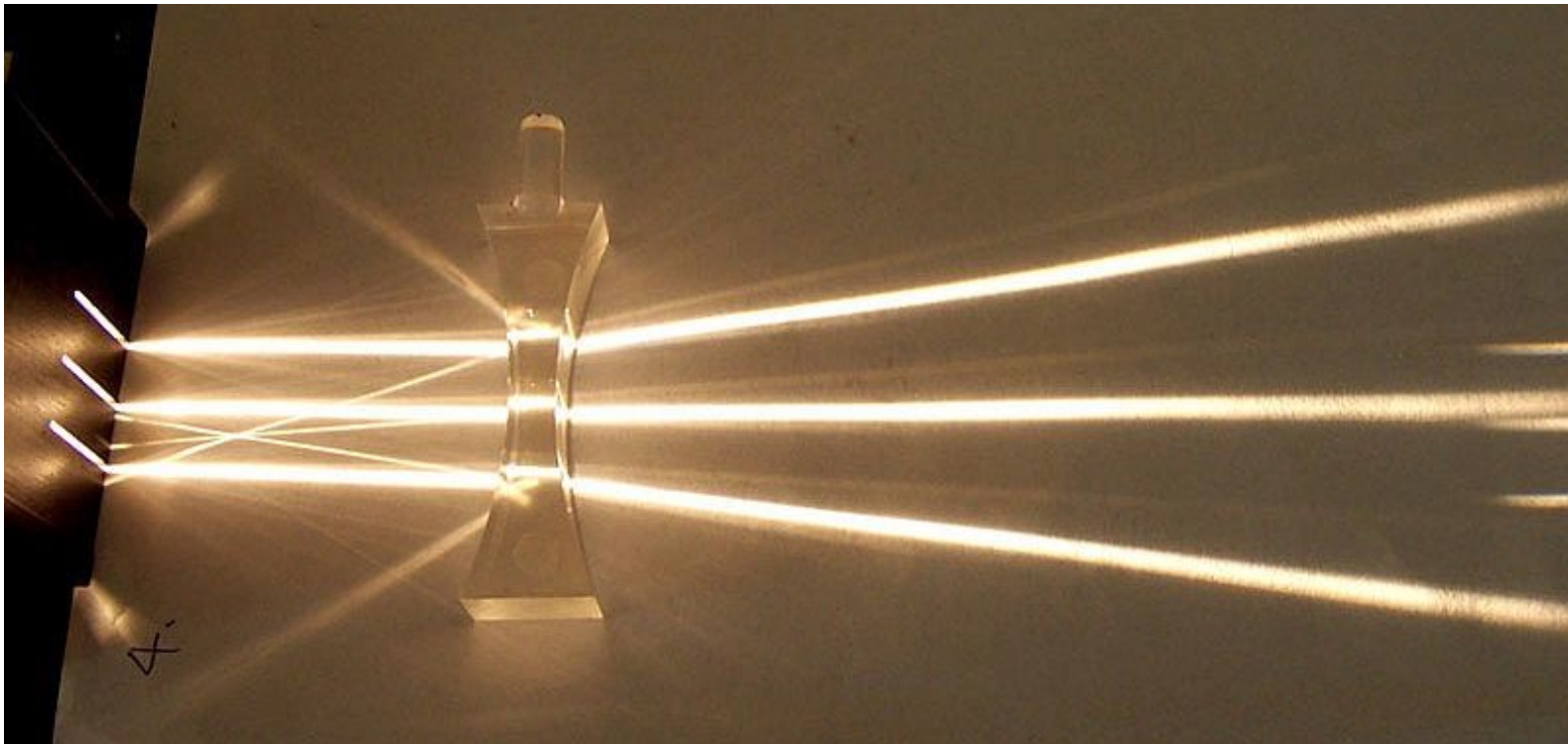

# Thin Lens Approximation

- ◆ Recall that the thin lens formula (for lenses with spherical surfaces,  $R_1 = R_2$ )

$$\frac{1}{o} + \frac{1}{i} = \frac{1}{f}$$

assumes

-  $d \ll R_1, R_2$

- ◆ In reality, what actually happens? Refraction occurs at the two lens surfaces.

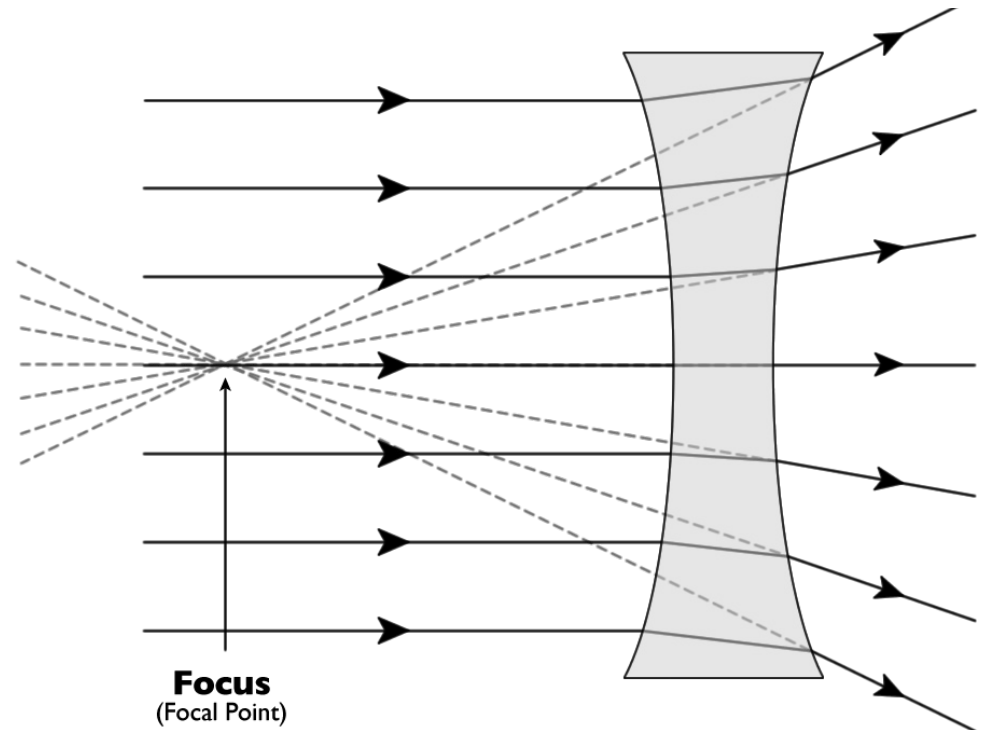
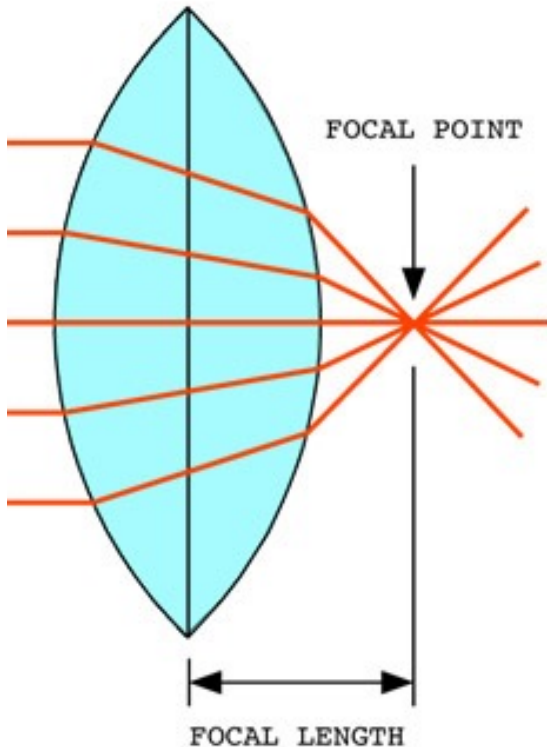

# Thin Lens Approximation

- ◆ Recall that the thin lens formula (for lenses with spherical surfaces,  $R_1 = R_2$ )

$$\frac{1}{o} + \frac{1}{i} = \frac{1}{f}$$

assumes

-  $d \ll R_1, R_2$

- ◆ The thin lens approximation becomes progressively worse at larger distances from the principal axis.

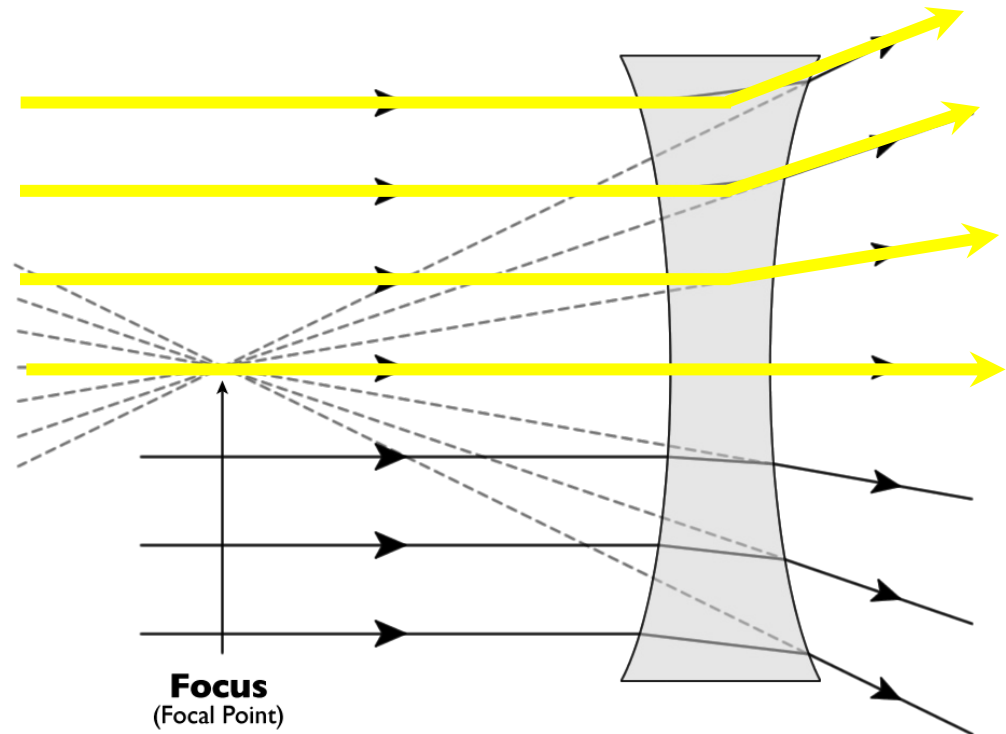
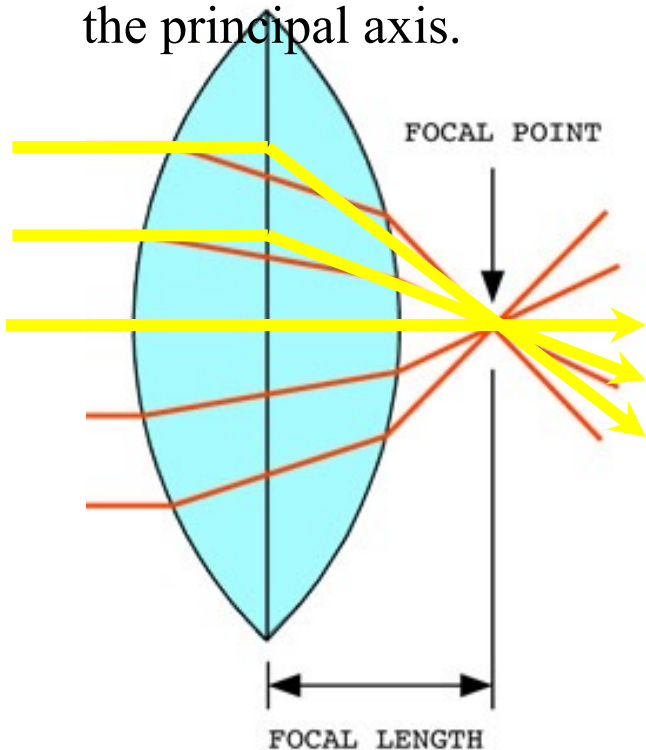

# Thin Lens Approximation

---

- ◆ Recall that the thin lens formula (for lenses with spherical surfaces,  $R_1 = R_2$ )

$$\boxed{\frac{1}{o} + \frac{1}{i} = \frac{1}{f}}$$

assumes

-  $d \ll R_1, R_2$

- ◆ The thin lens formula is only an *approximation* that is close to exact for rays at small distances from and at small angles to the principal axis.

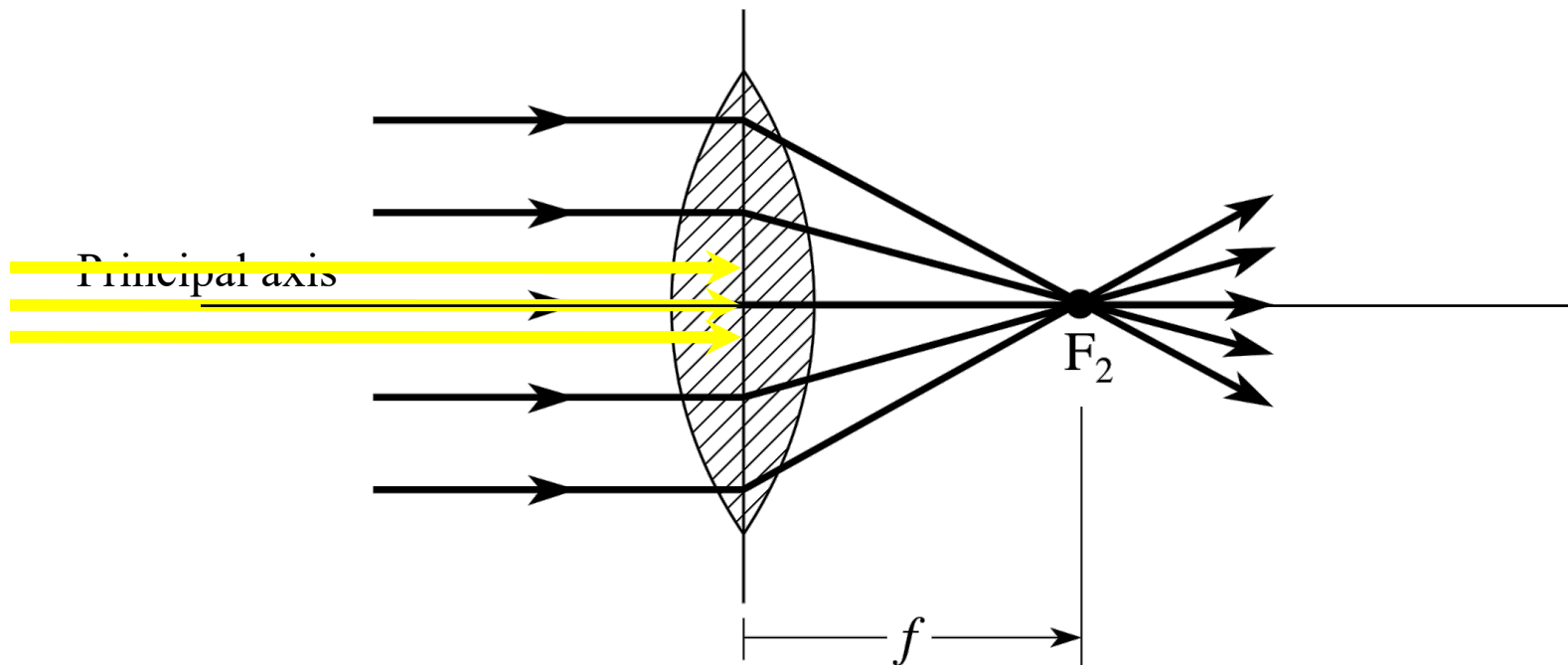

# Thin Lens Approximation

---

- ◆ Recall that the thin lens formula (for lenses with spherical surfaces,  $R_1 = R_2$ )

$$\boxed{\frac{1}{o} + \frac{1}{i} = \frac{1}{f}}$$

assumes

-  $d \ll R_1, R_2$

- ◆ The thin lens formula is only an *approximation* that is close to exact for rays at small distances from and at small angles to the principal axis.

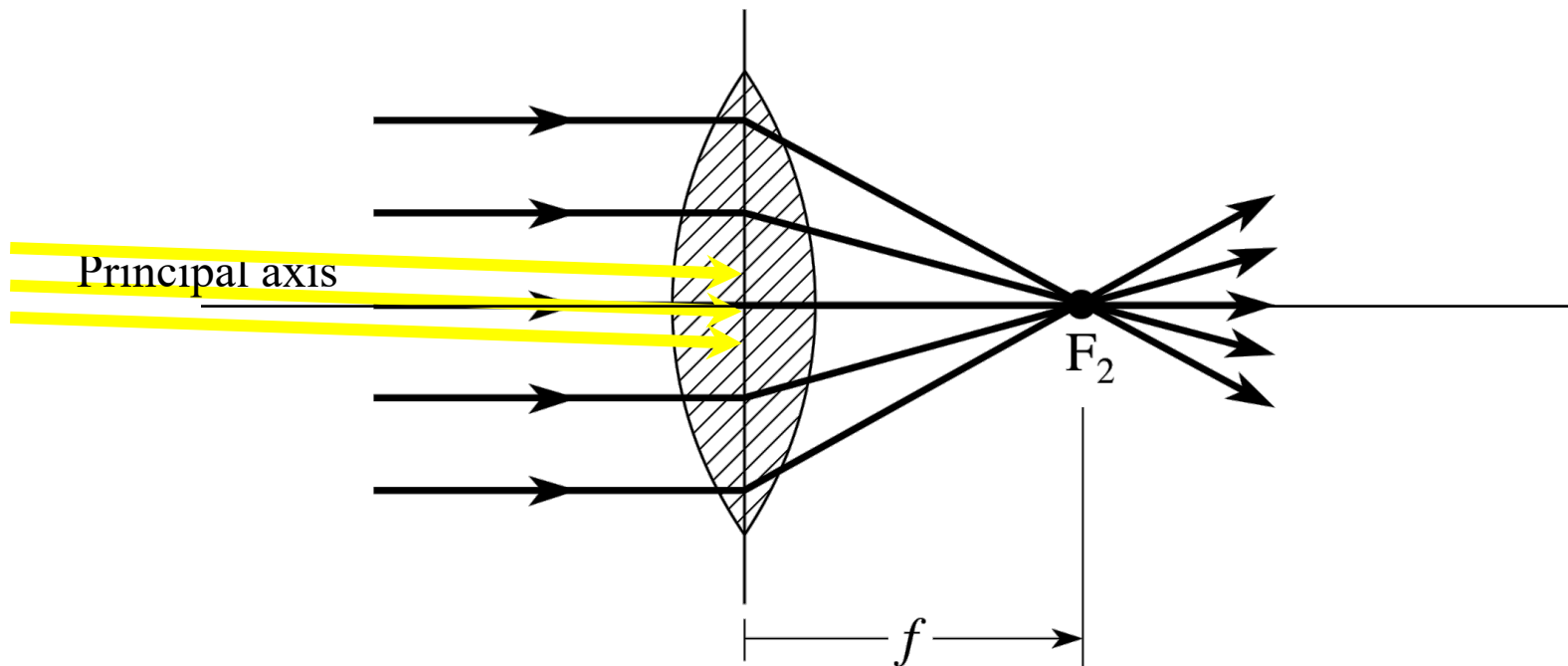

# Thin Lens Approximation

---

- ◆ Recall that the thin lens formula (for lenses with spherical surfaces,  $R_1 = R_2$ )

$$\boxed{\frac{1}{o} + \frac{1}{i} = \frac{1}{f}}$$

assumes

-  $d \ll R_1, R_2$

- ◆ The thin lens formula is only an *approximation* that is close to exact for rays at small distances from and at small angles to the principal axis.

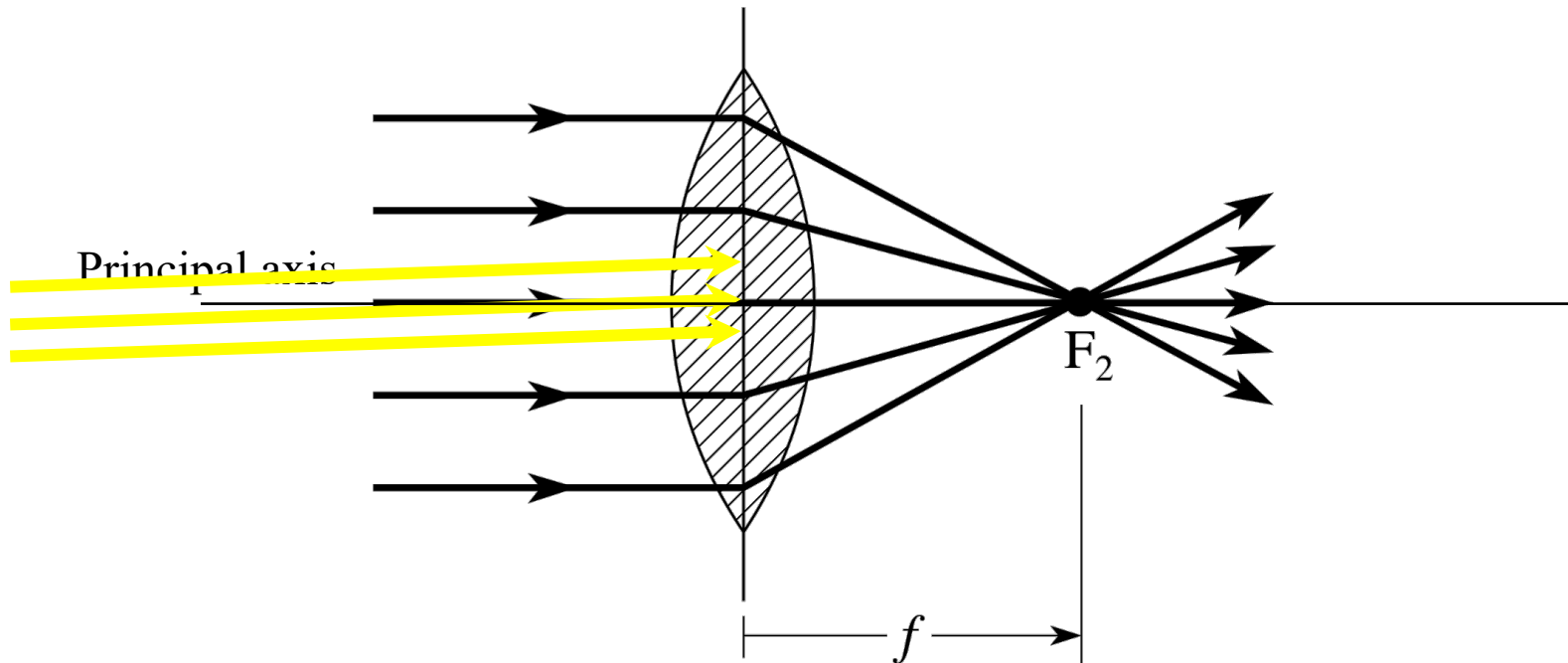

# Mirror Equation Approximation

## ◆ Derivation of the **mirror equation**

$$\frac{1}{o} + \frac{1}{i} = \frac{1}{f}$$

assumes mirror segment much smaller than its radius of curvature.

- ◆ Equivalently, the mirror equation is only an *approximation* that is close to exact for rays at small distances from and at small angles to the principal axis.

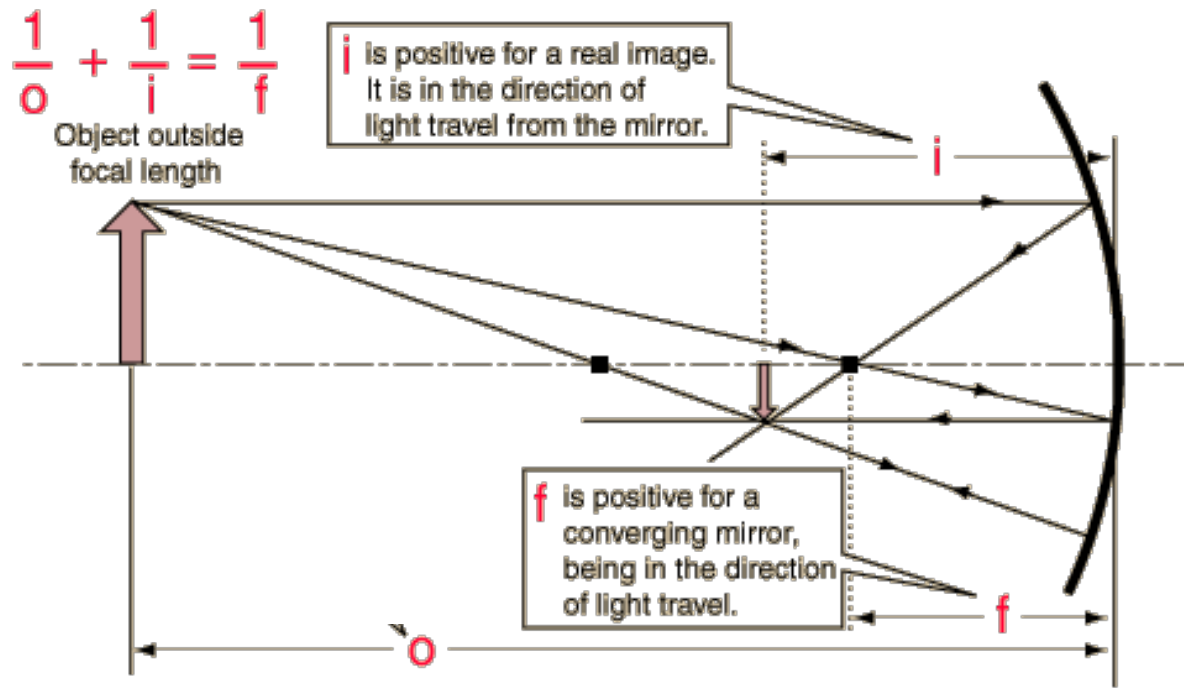

# Specchio sferico

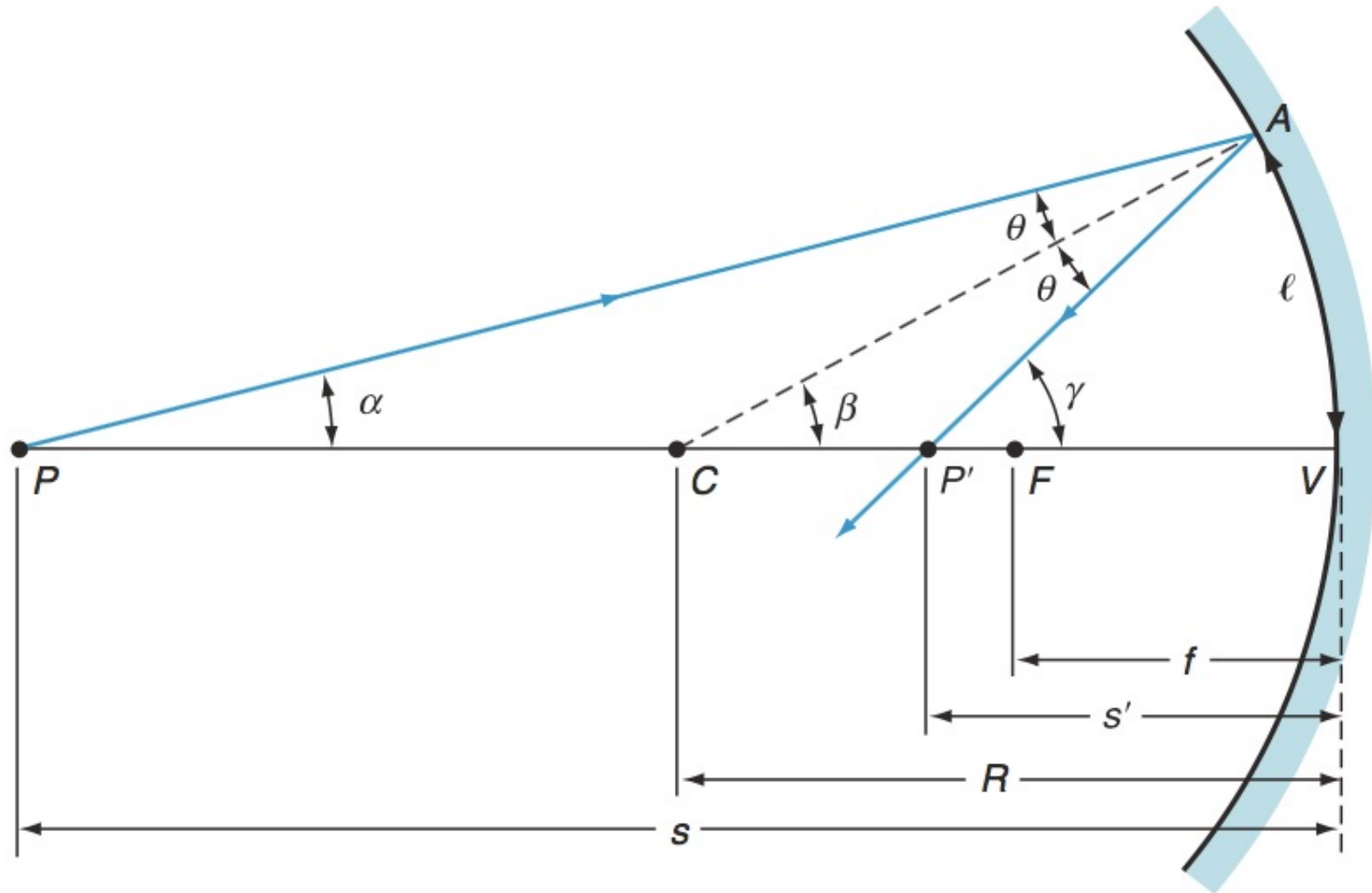



# Specchio sferico

Triangolo PAC:  $\beta = \alpha + \theta$

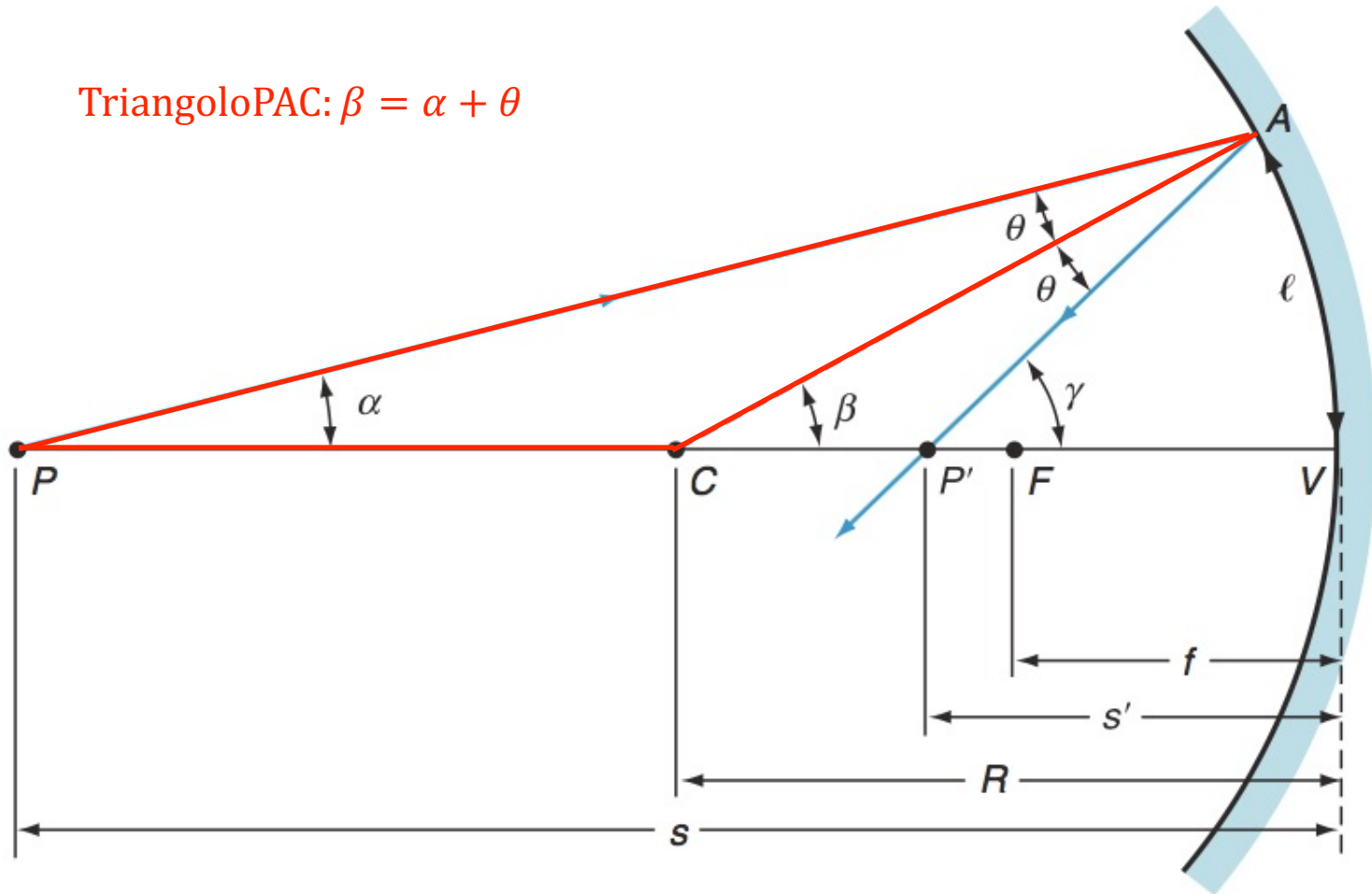

# Specchio sferico

Triangolo PAC:  $\beta = \alpha + \theta$

Triangolo PAP':  $\gamma = \alpha + 2\theta$

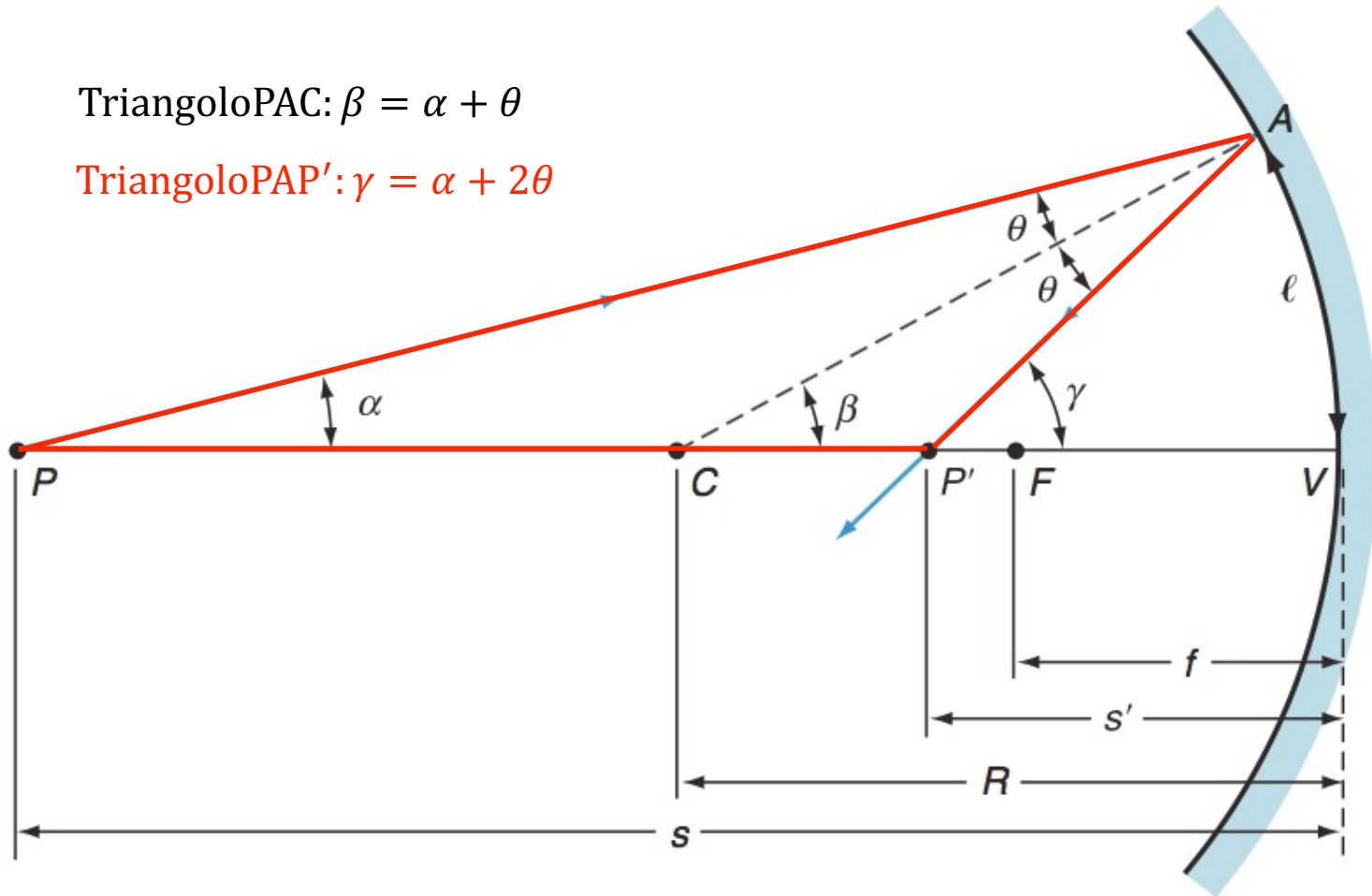

# Specchio sferico

Triangolo  $PAC$ :  $\beta = \alpha + \theta$

Triangolo  $PAP'$ :  $\gamma = \alpha + 2\theta$

$$\alpha + \gamma = 2\beta$$

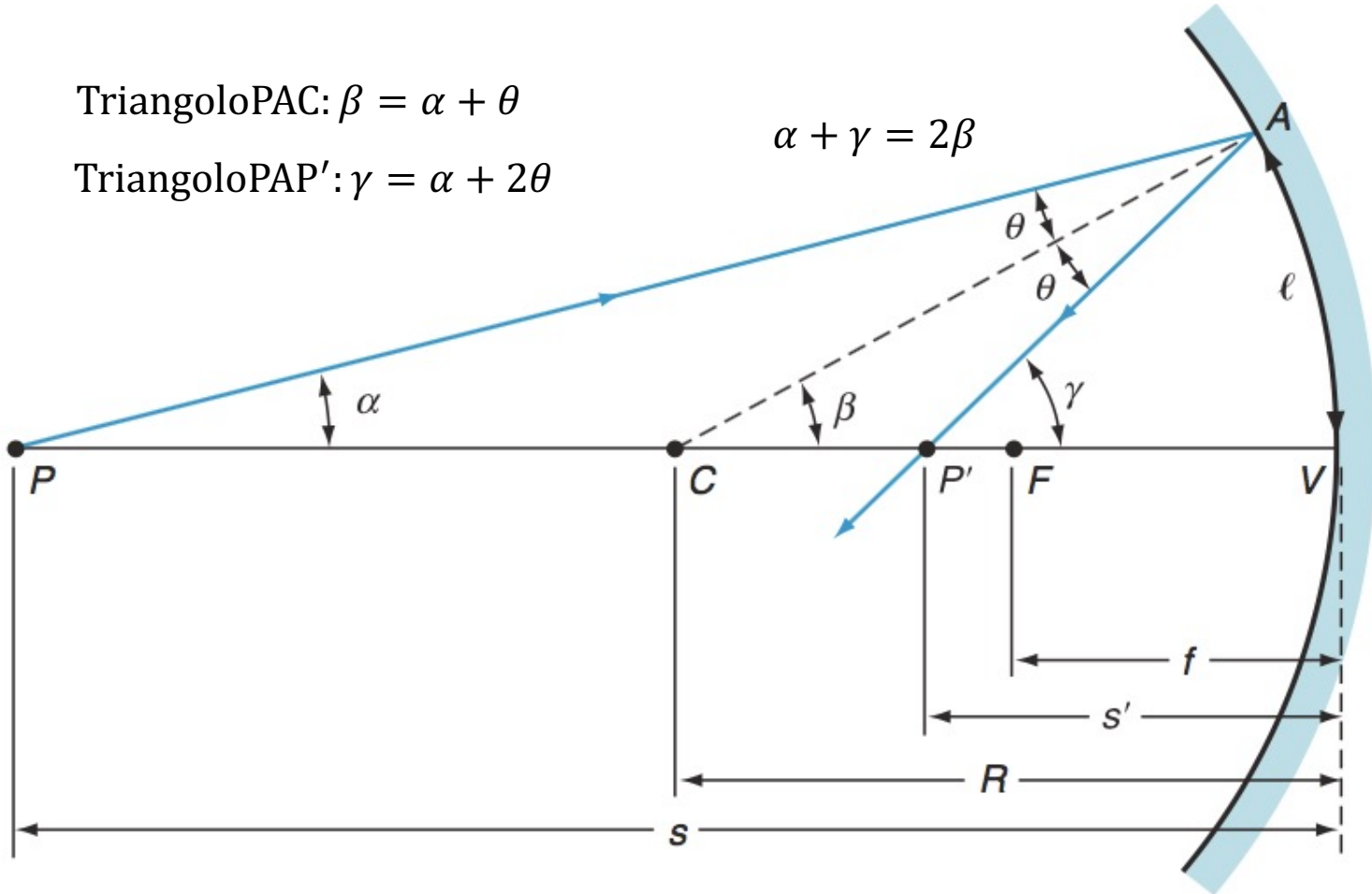

# Specchio sferico

$$\alpha + \gamma = 2\beta$$

*Approssimazione di Gauss*

$$\alpha \ll 1, \beta \ll 1, \gamma \ll 1 \Rightarrow \alpha \approx \frac{\ell}{s}, \beta = \frac{\ell}{R}, \gamma \approx \frac{\ell}{s'}$$

$$\frac{1}{s} + \frac{1}{s'} = \frac{2}{R}$$

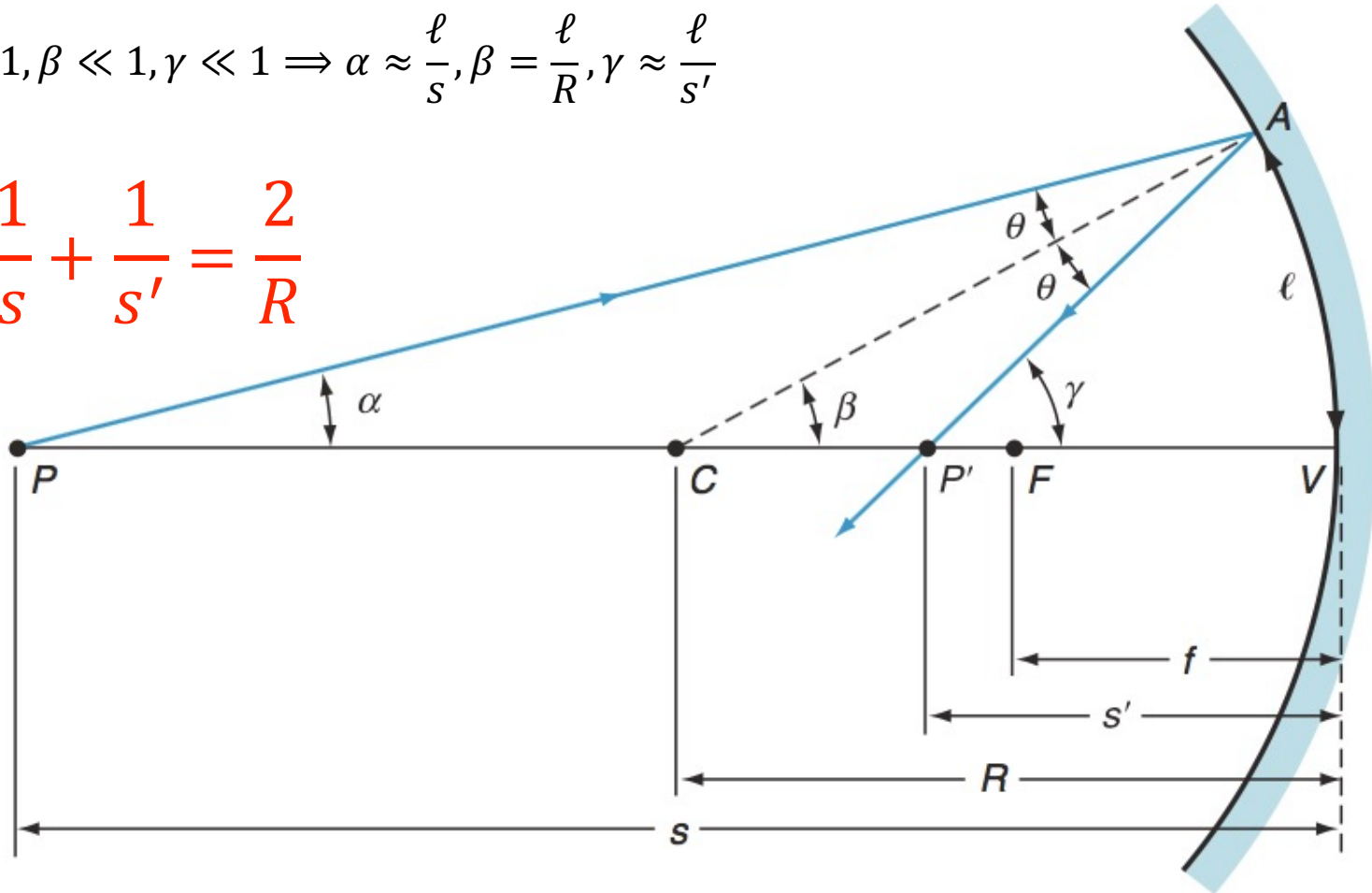

# Equazione degli specchi

$$\frac{1}{s} + \frac{1}{s'} = \frac{2}{R}$$

$$\frac{1}{s} + \frac{1}{s'} = \frac{1}{f}$$

$$s \rightarrow \infty \Rightarrow s' = \frac{R}{2} \equiv f$$

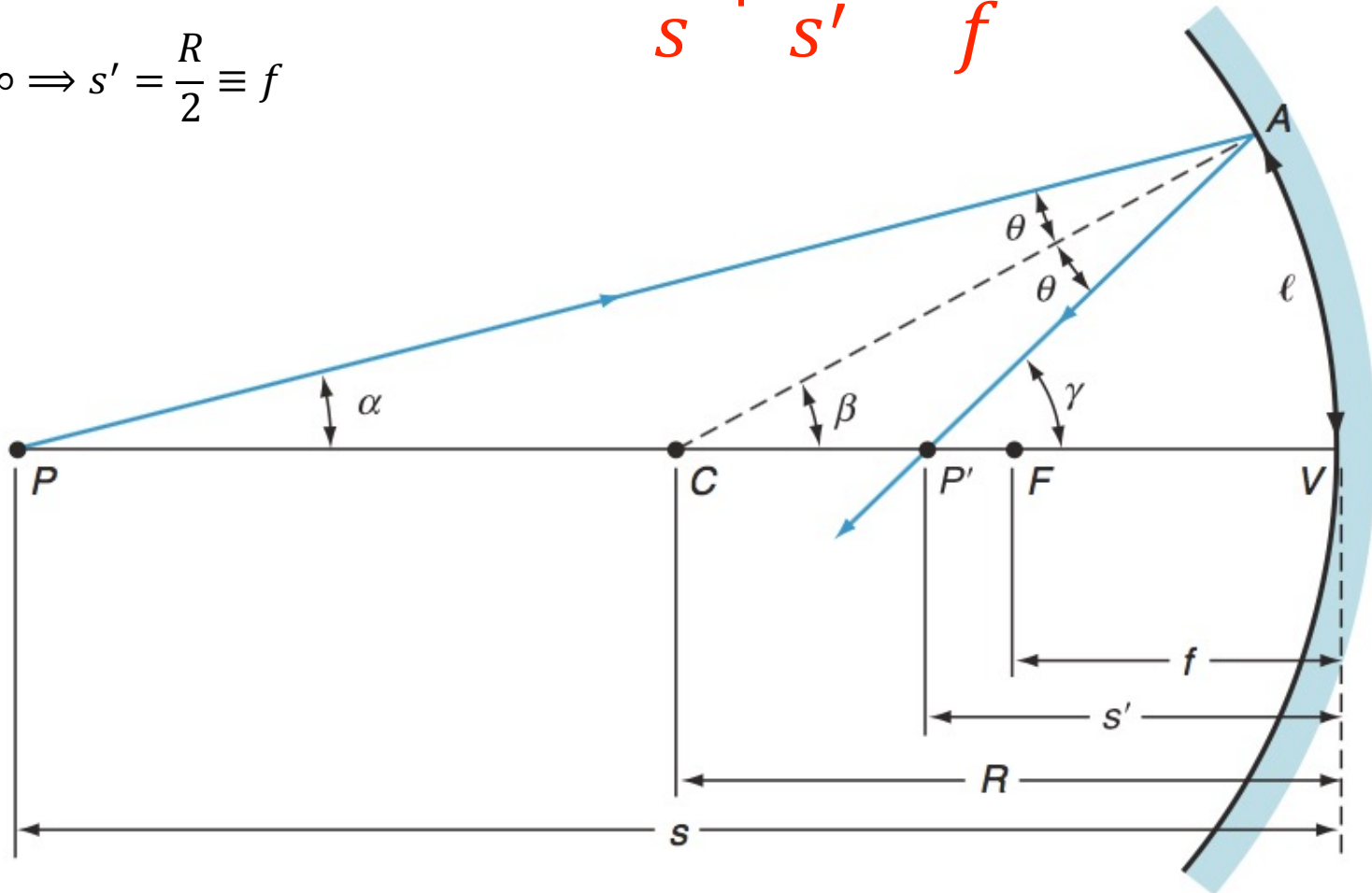

# Esercizio: specchio parabolico

Ogni raggio parallelo all'asse della parabola viene riflesso nel suo fuoco.

Si dimostra che:

- il triangolo FPQ e' isoscele,
- gli angoli  $\alpha$  e  $\gamma$  sono uguali,
- gli angoli  $\theta_1$  e  $\theta_2$  sono uguali,
- la retta  $t$  bisettrice del triangolo isoscele e' tangente alla parabola.

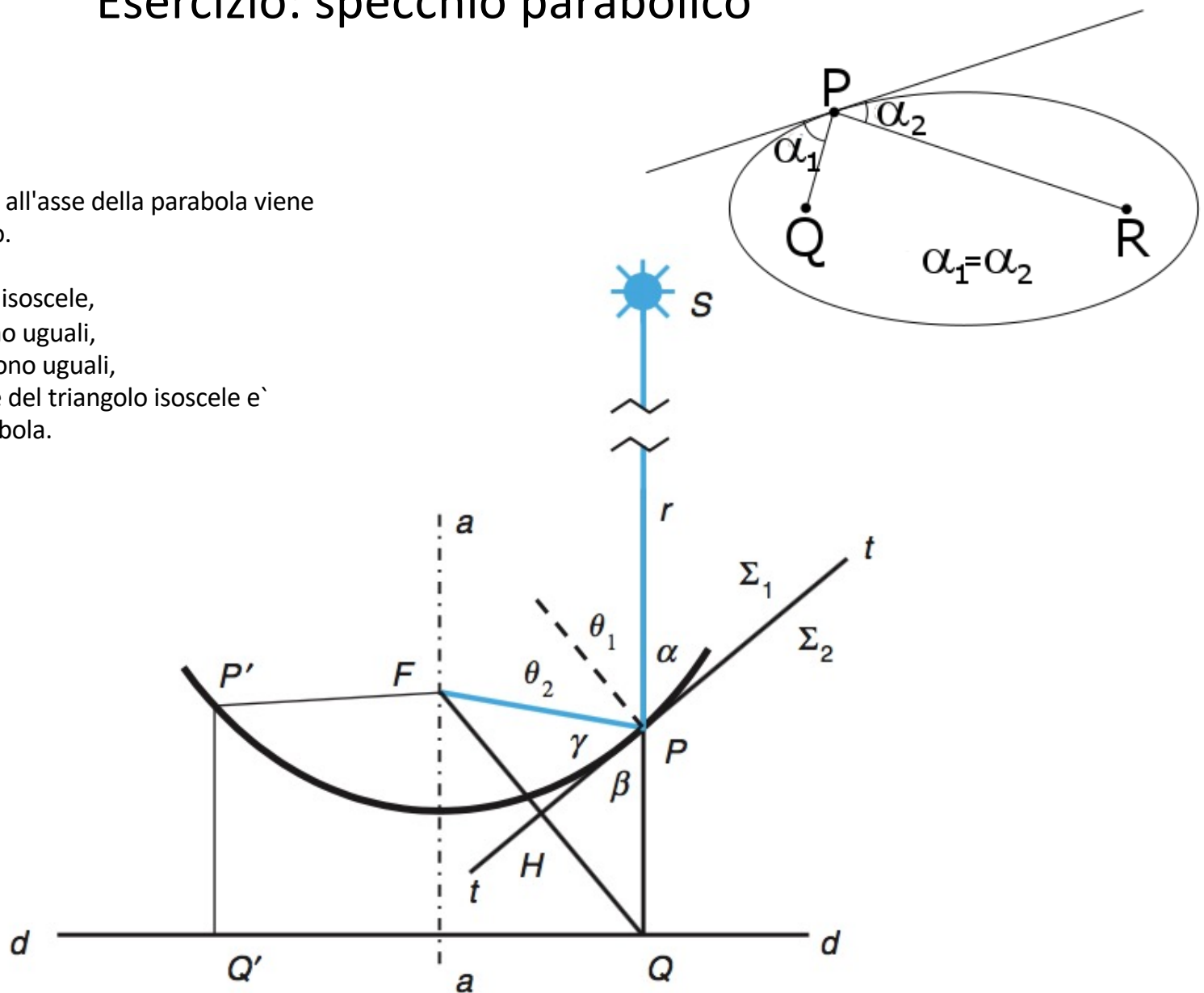

# Spherical Aberration

- ◆ Light rays that strike closer to the edge of a spherical lens suffer greater refraction than those striking closer to its principal axis, thus focusing at a different point (closer to the lens) along the principal axis.

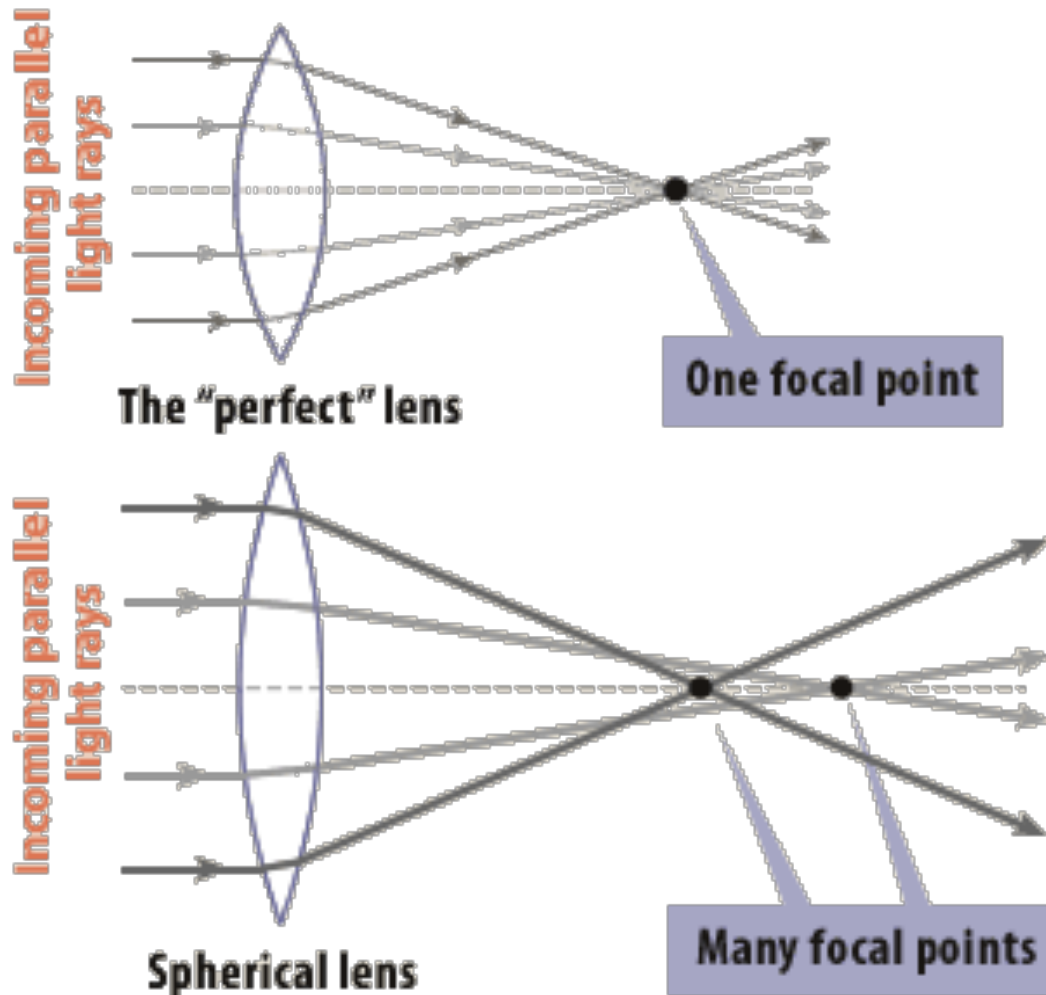

# Spherical Aberration

- ◆ Before the age of computer-controlled machining, the easiest surfaces to manufacture were flat or spherical surfaces.
- ◆ How can spherical aberration be reduced or avoided?

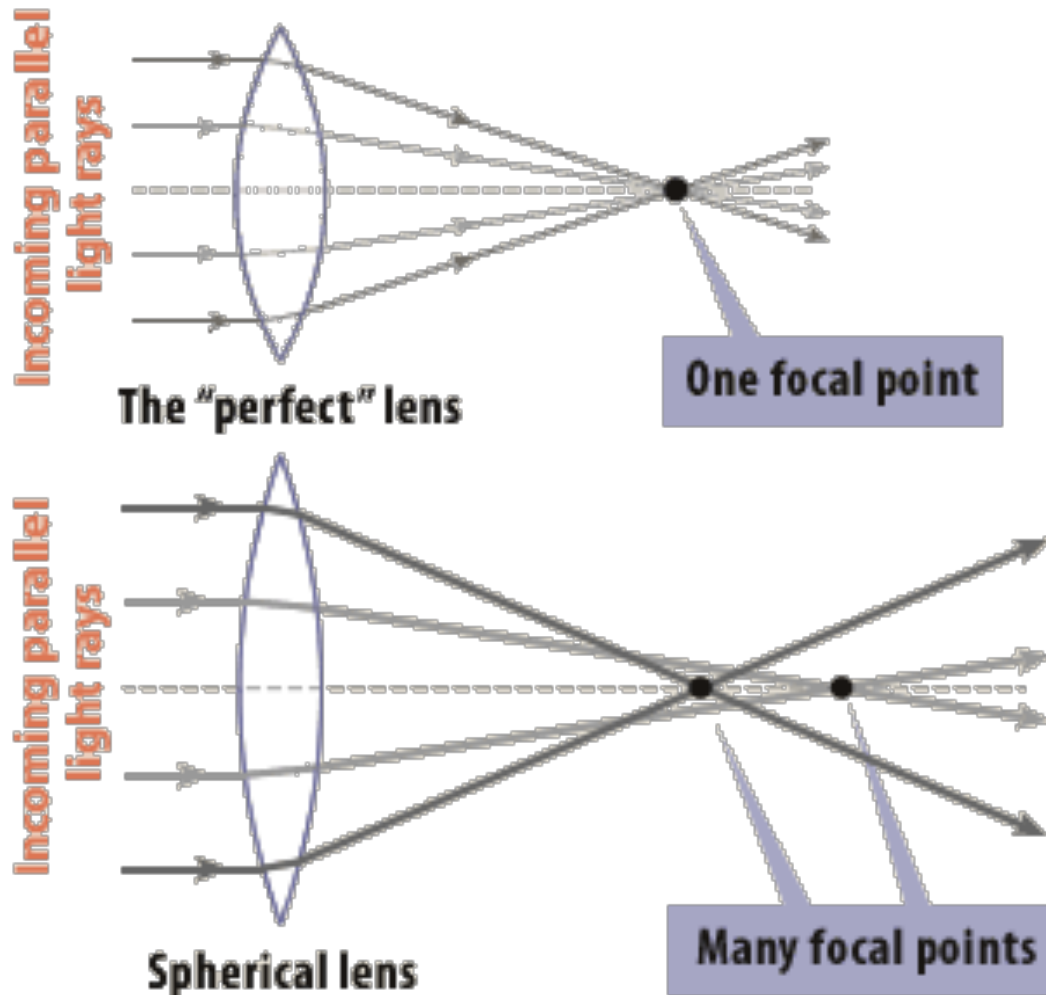



# Spherical Aberration

---

- ◆ Make the surface flatter so that light rays striking closer to the edge of the lens suffer similar refraction as those striking closer to its principal axis.
- ◆ An example of such a shape is a parabola, which completely eliminates spherical aberration.

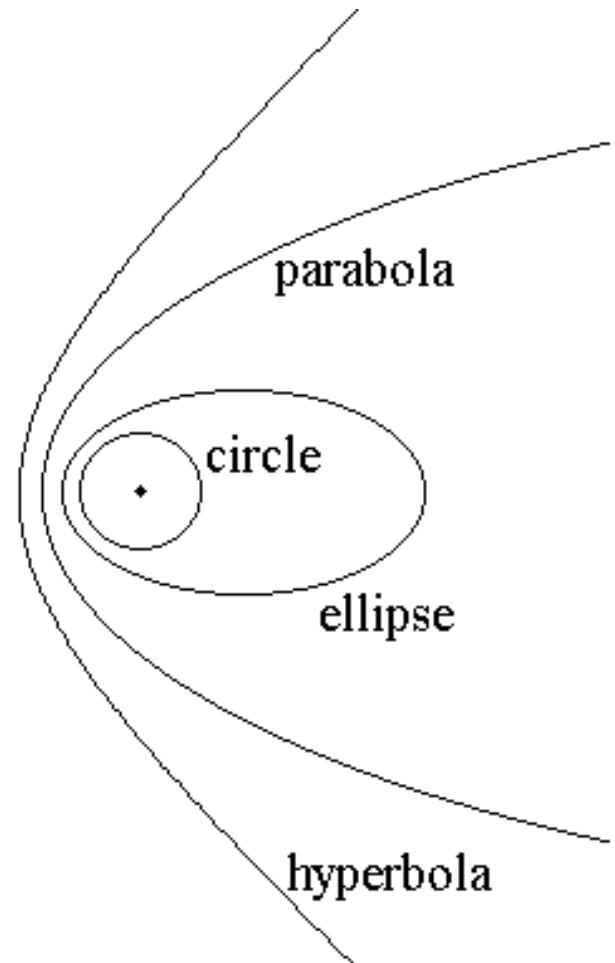
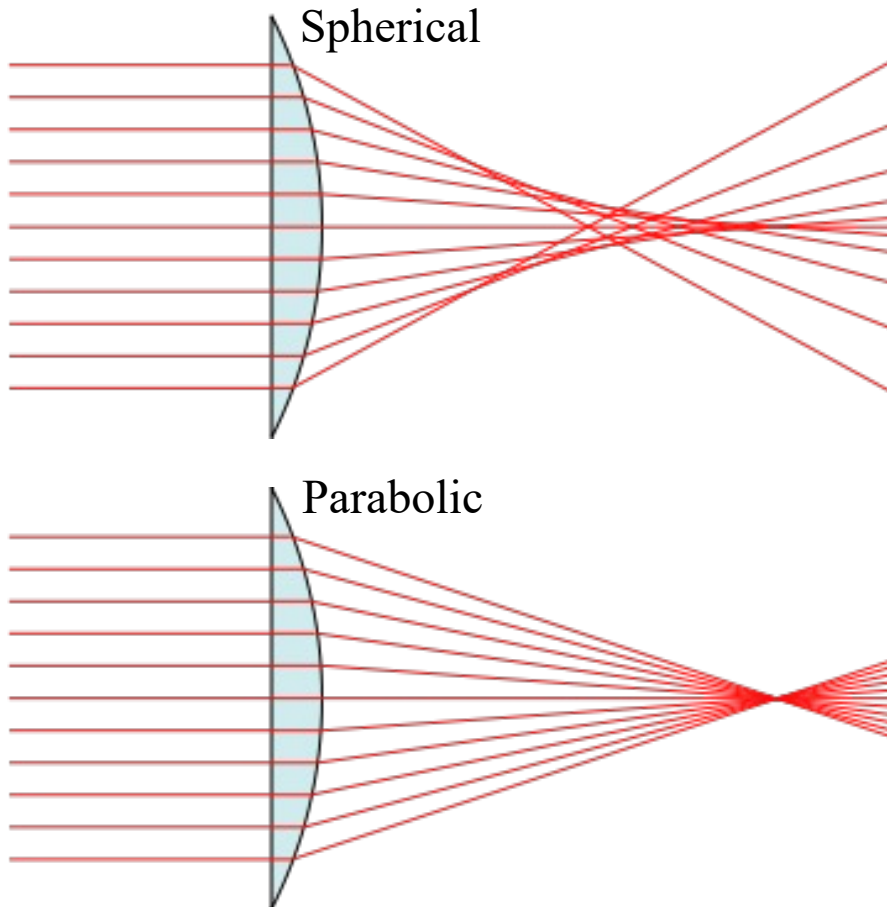

# Spherical Aberration

---

- ◆ Make the surface flatter so that light rays striking closer to the edge of the lens suffer similar refraction as those striking closer to its principal axis.
- ◆ An example of such a shape is a parabola, which completely eliminates spherical aberration.

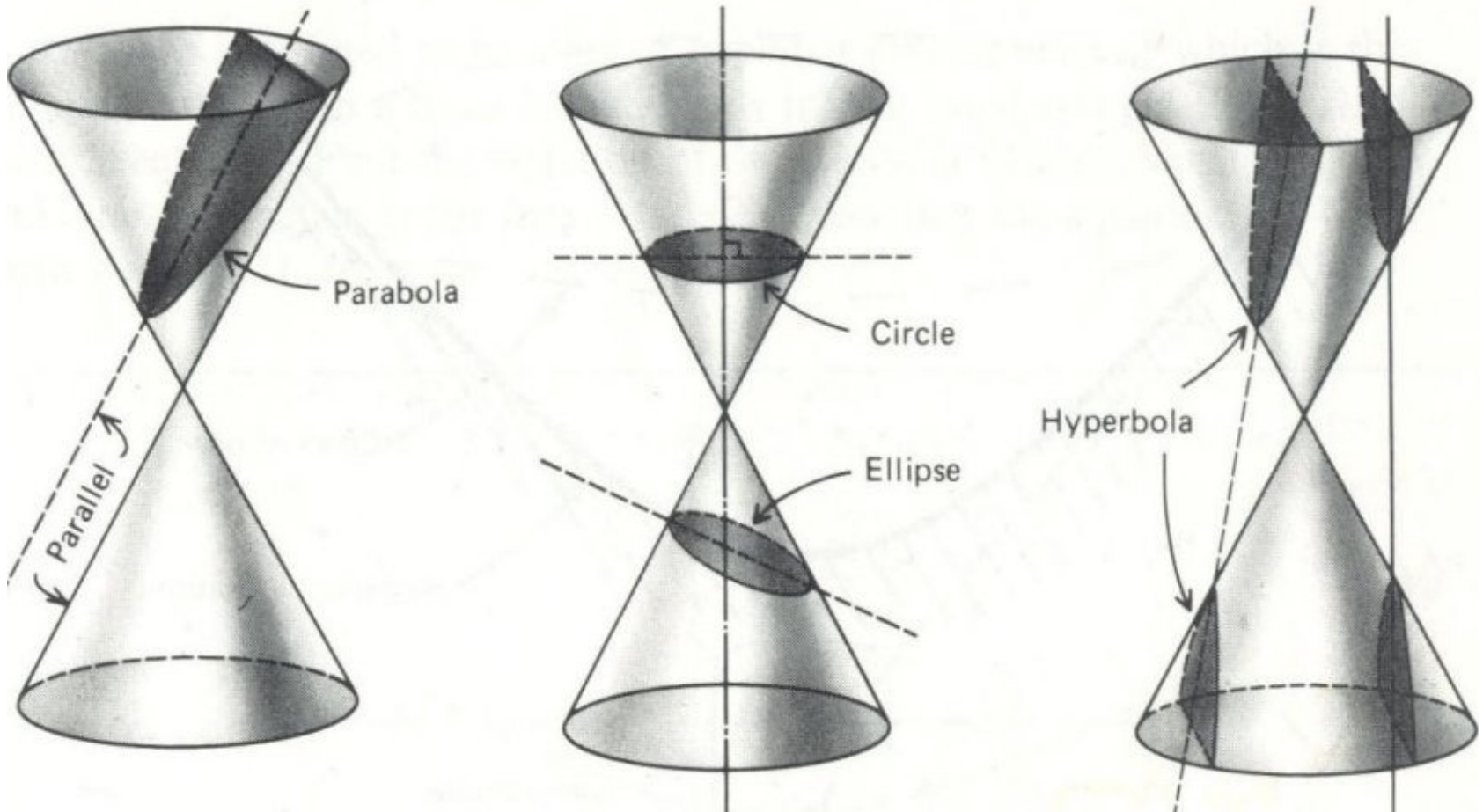

# Spherical Aberration

---

- ◆ Light rays that strike closer to the edge of a spherical mirror focus at a different point (closer to the mirror) along the principal axis.
- ◆ How can spherical aberration be reduced or avoided?

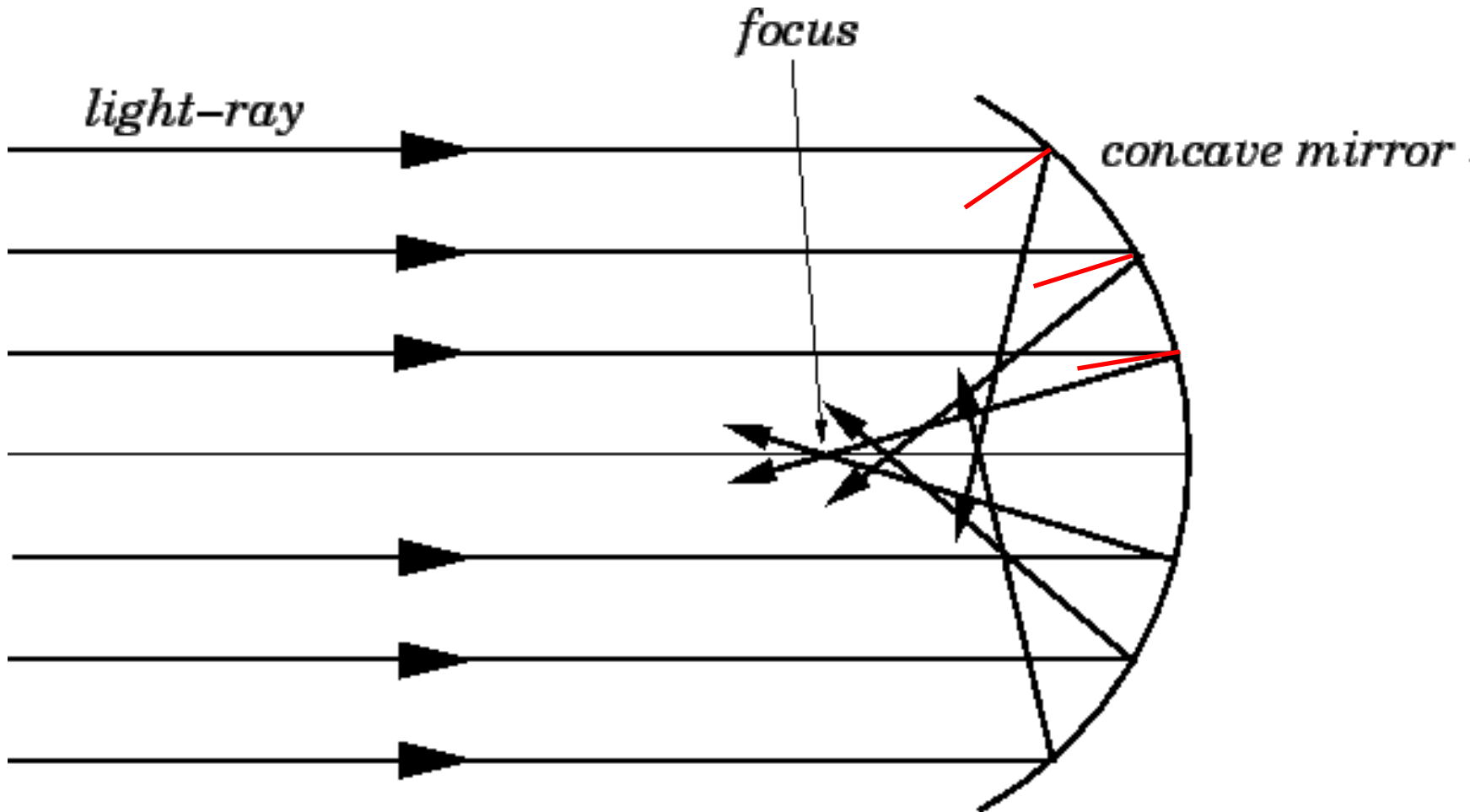

# Spherical Aberration

---

- ◆ Make the surface flatter so that light rays striking closer to the edge of the mirror focus at the same point as those striking closer to its principal axis.
- ◆ An example of such a shape is a parabola, which completely eliminates spherical aberration.

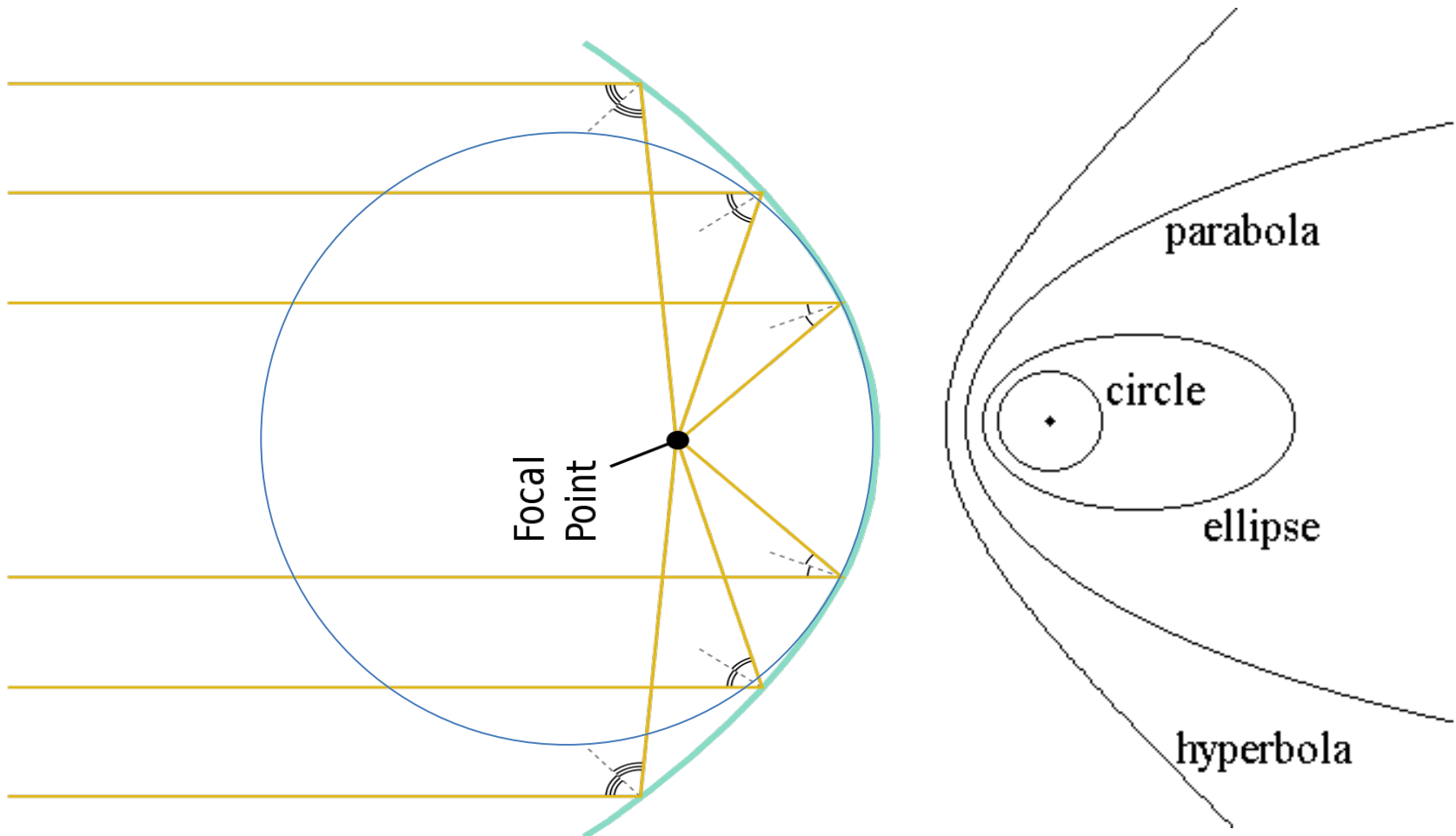

# Spherical Aberration

---

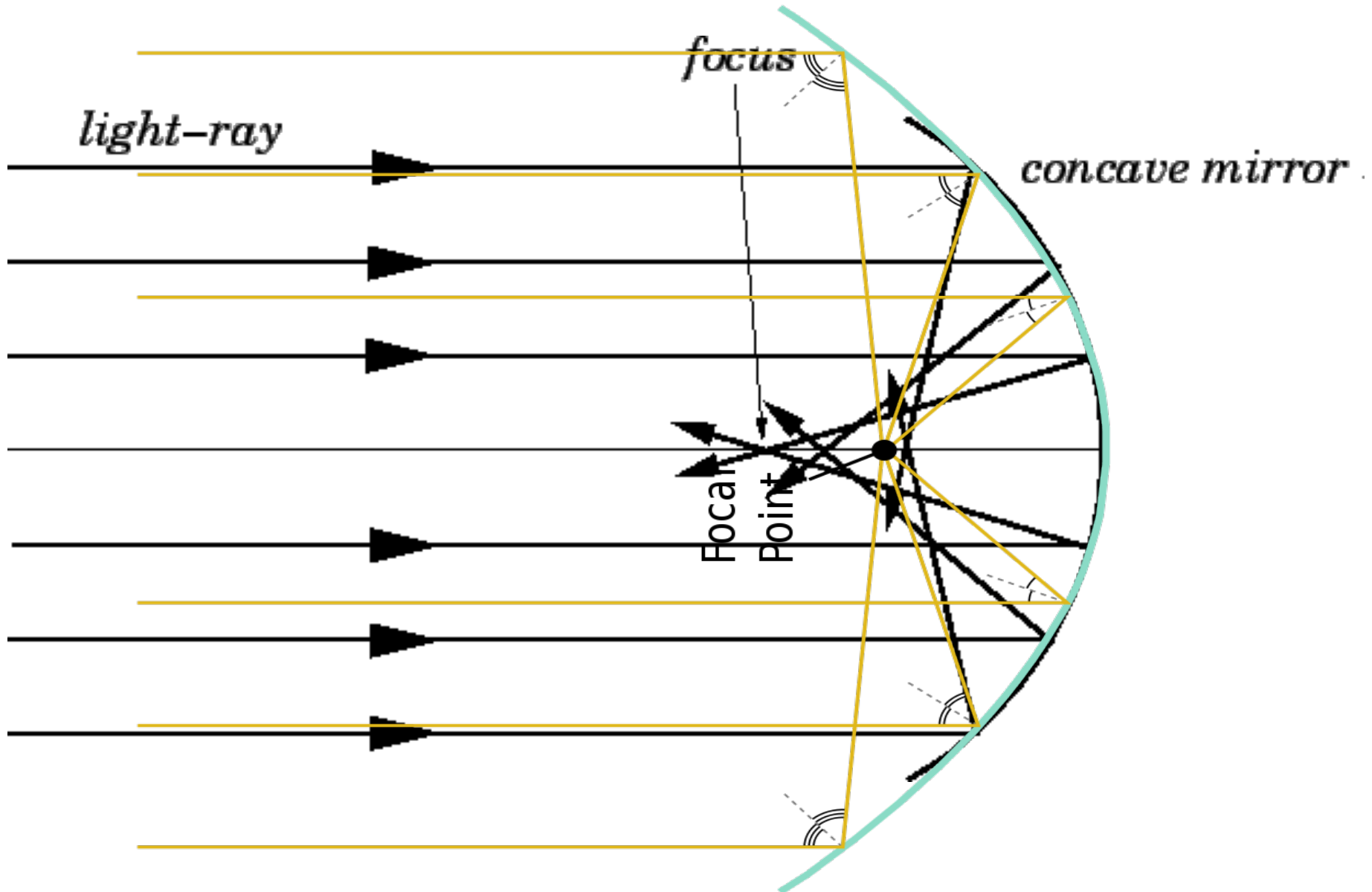

# Coma

- ◆ Light rays at an angle to and at different distances from the principal axis focus at different points along and at different heights above the principal axis. Comatic aberration happens even for parabolic surfaces.

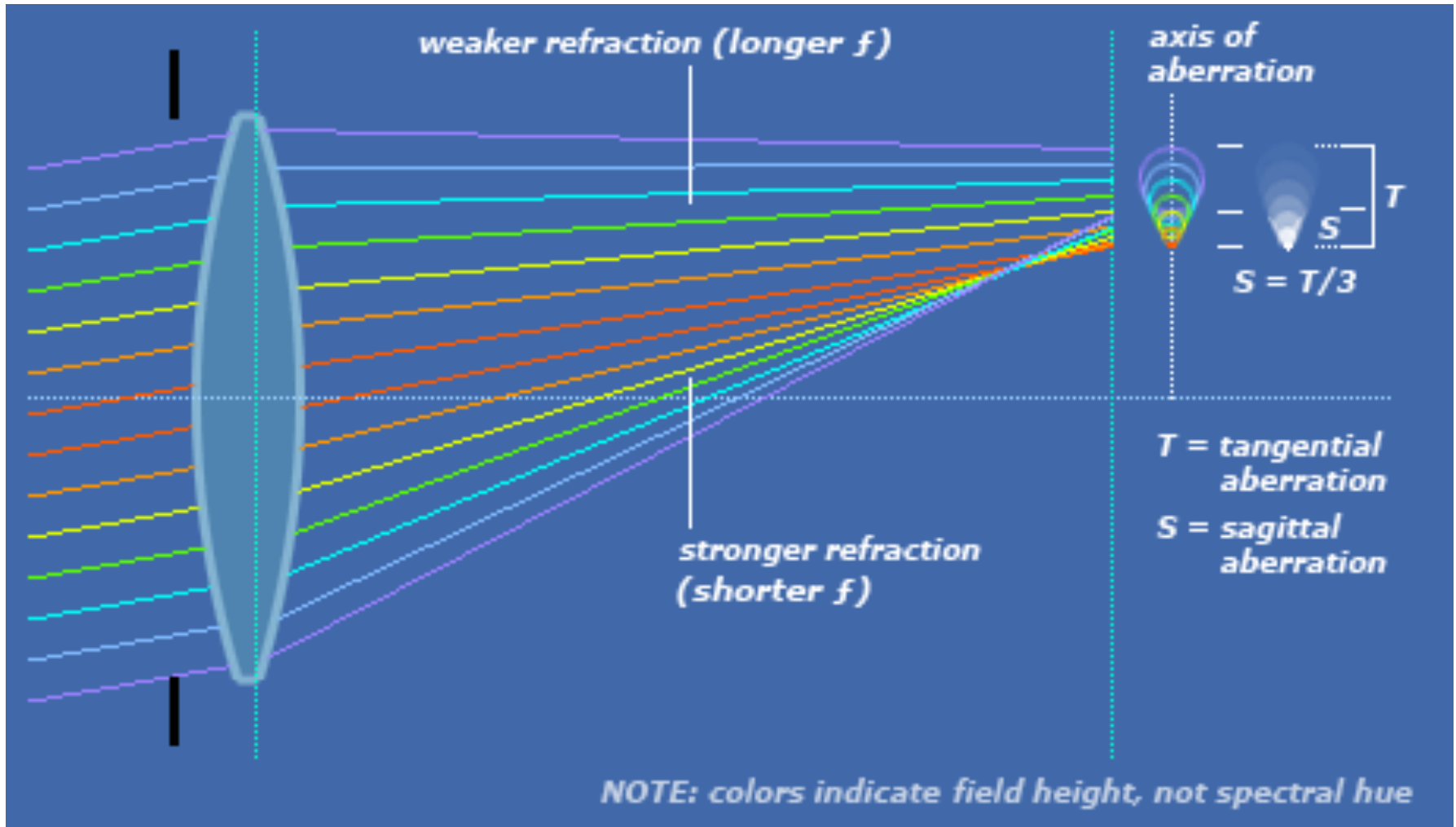

# Coma

- ◆ Light rays at an angle to and at different distances from the principal axis focus at different points along and at different heights above the principal axis. Comatic aberration happens even for parabolic surfaces.

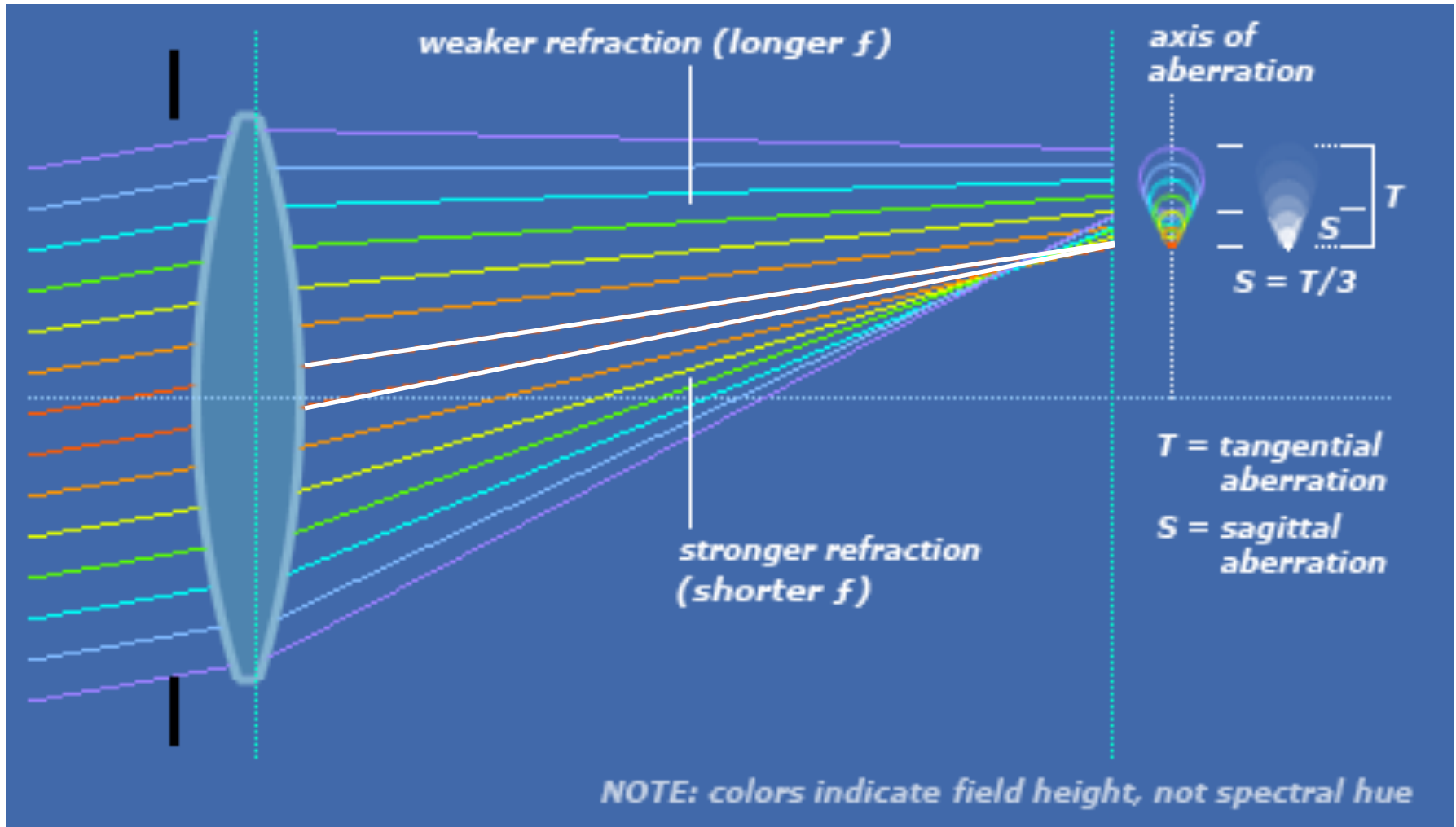

# Coma

- ◆ Light rays at an angle to and at different distances from the principal axis focus at different points along and at different heights above the principal axis. Comatic aberration happens even for parabolic surfaces.

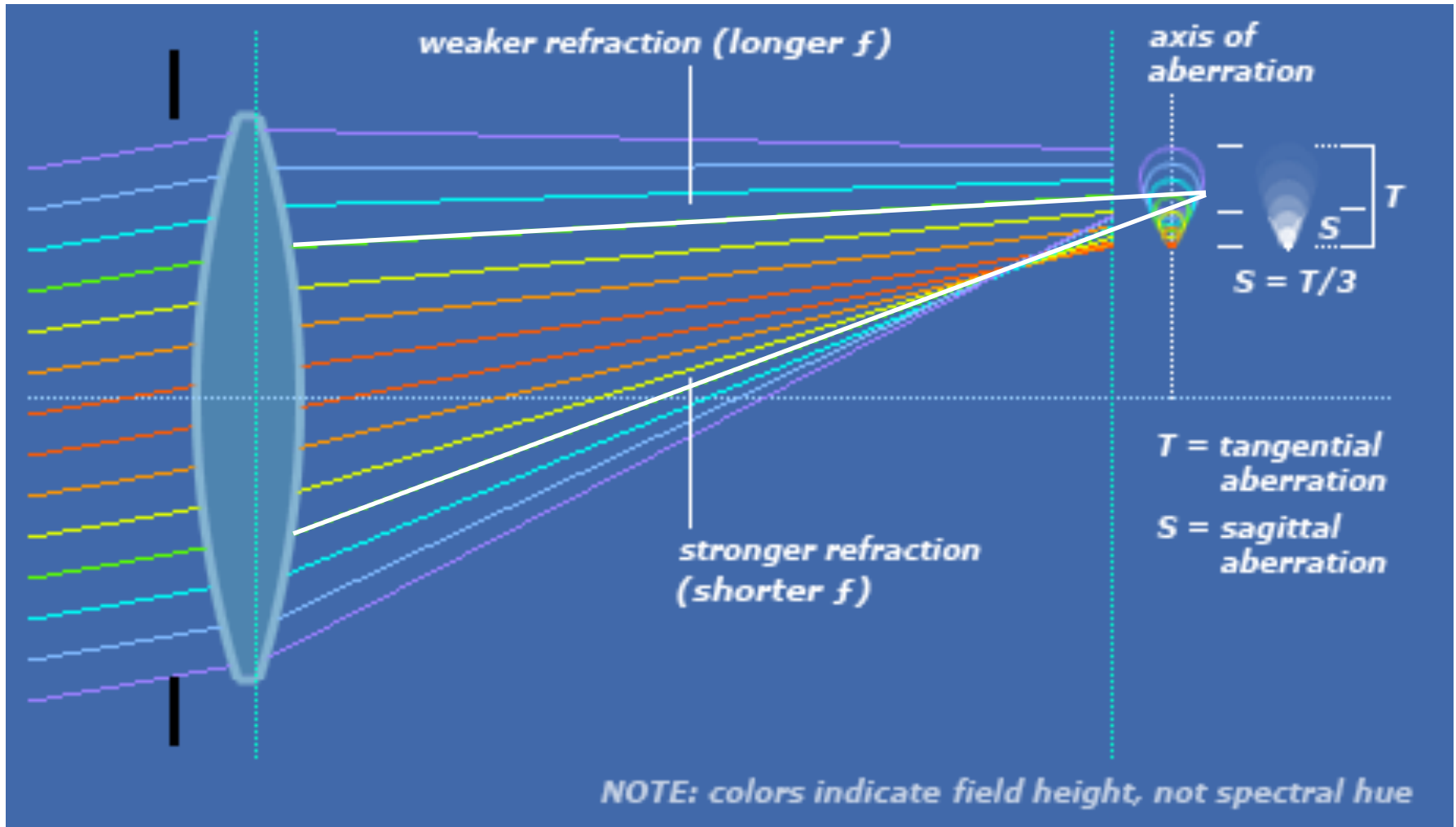



# Coma

- ◆ Light rays at an angle to and at different distances from the principal axis focus at different points along and at different heights above the principal axis. Comatic aberration happens even for parabolic surfaces.

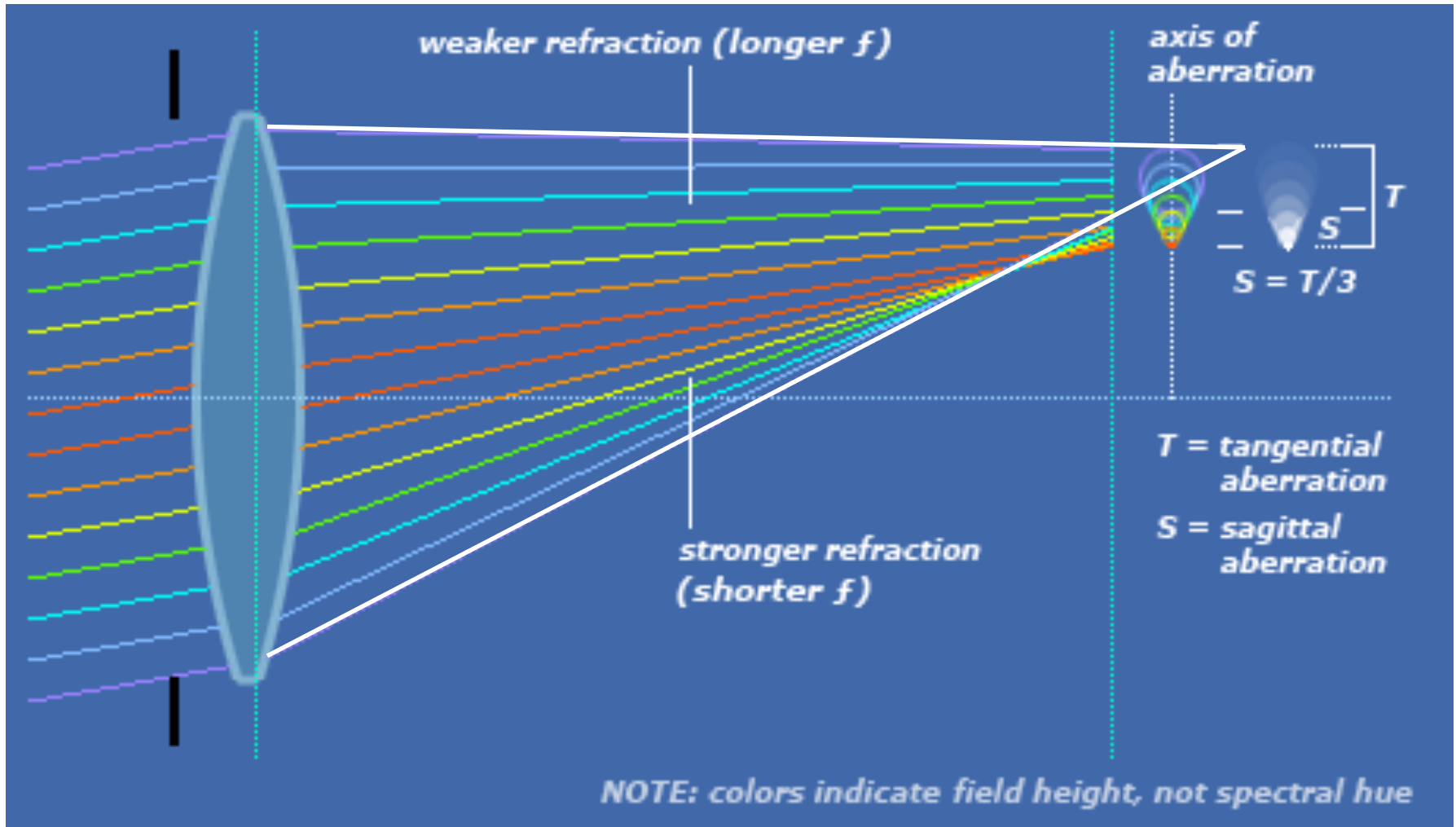

# Coma

- ◆ Result is an elongated image that looks like the coma of a comet.

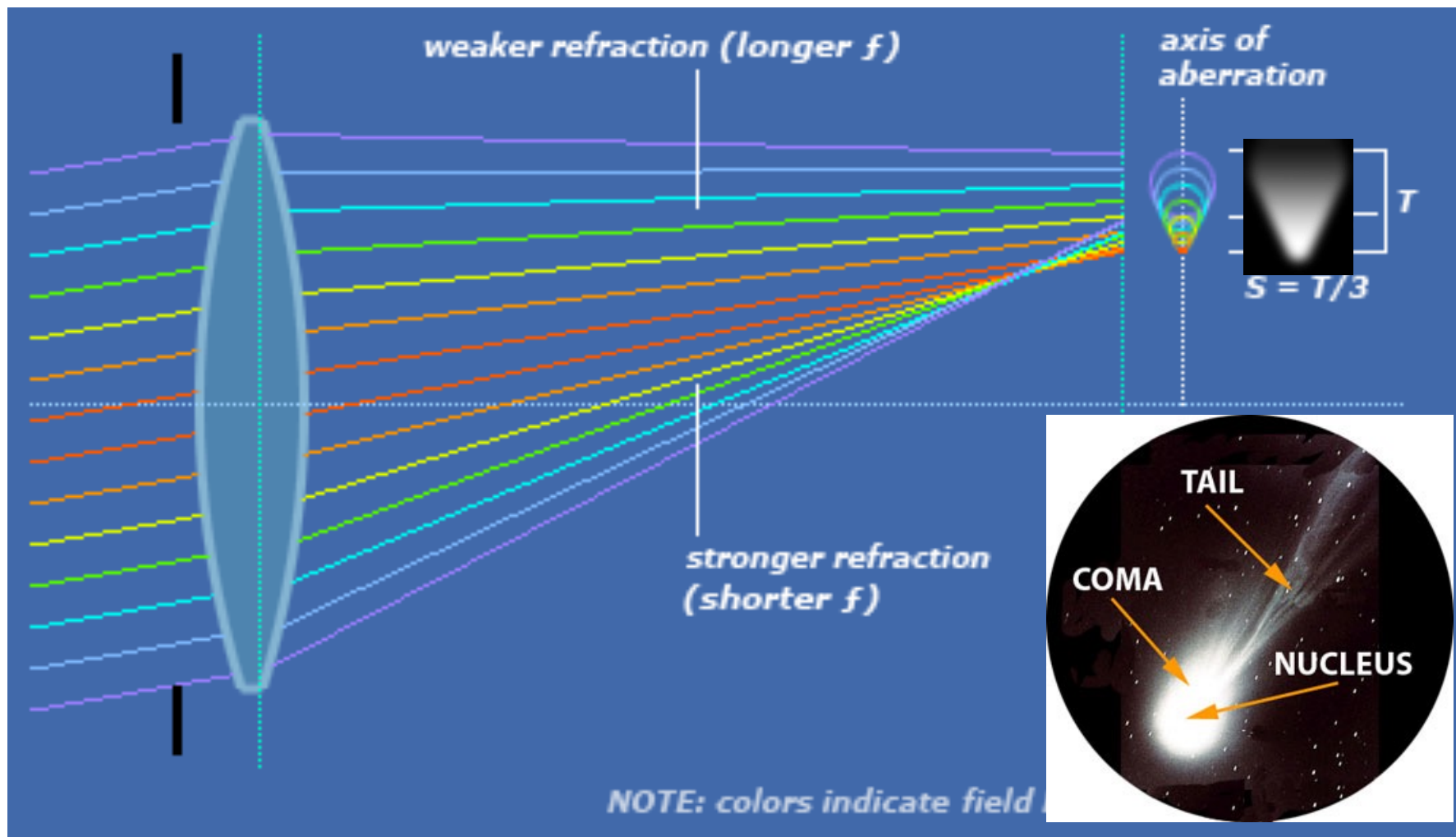

# Coma

---

- ◆ Comatic aberration becomes progressively worse for incident light rays at larger angles to the principal axis, and therefore becomes progressively worse towards the edge of the field.

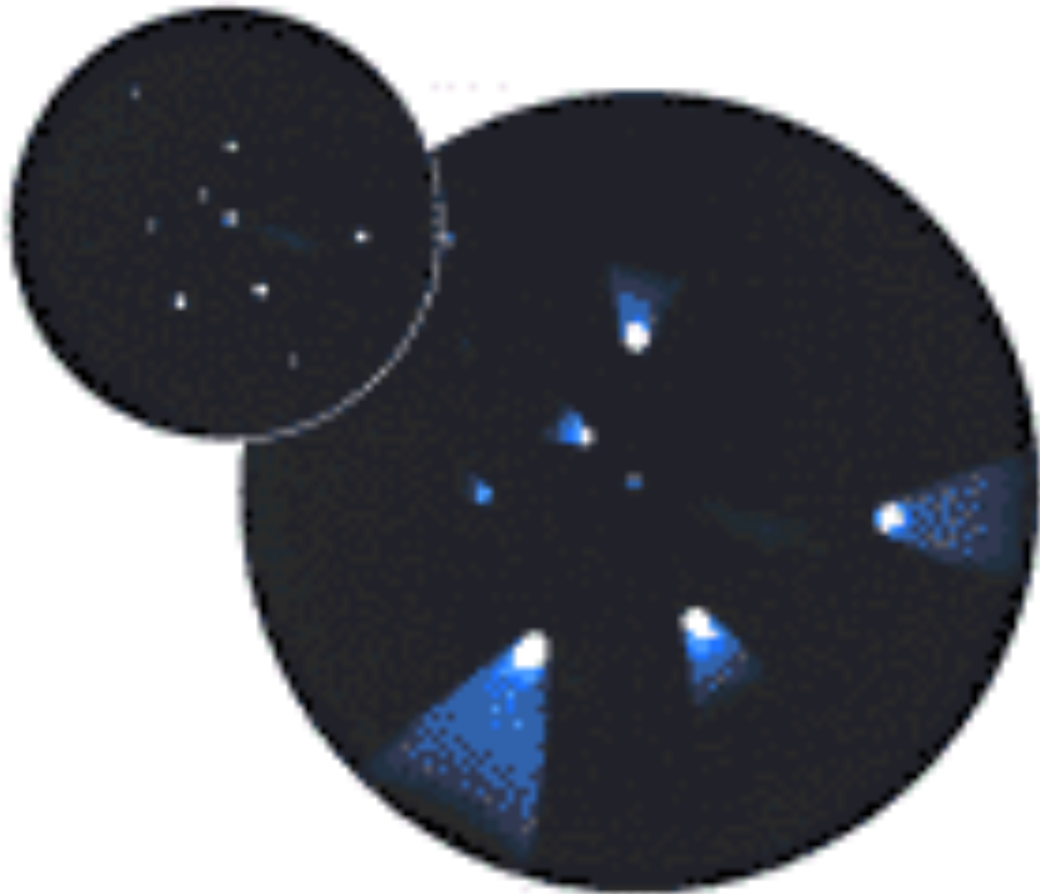

# Coma

- ◆ How can coma be reduced?

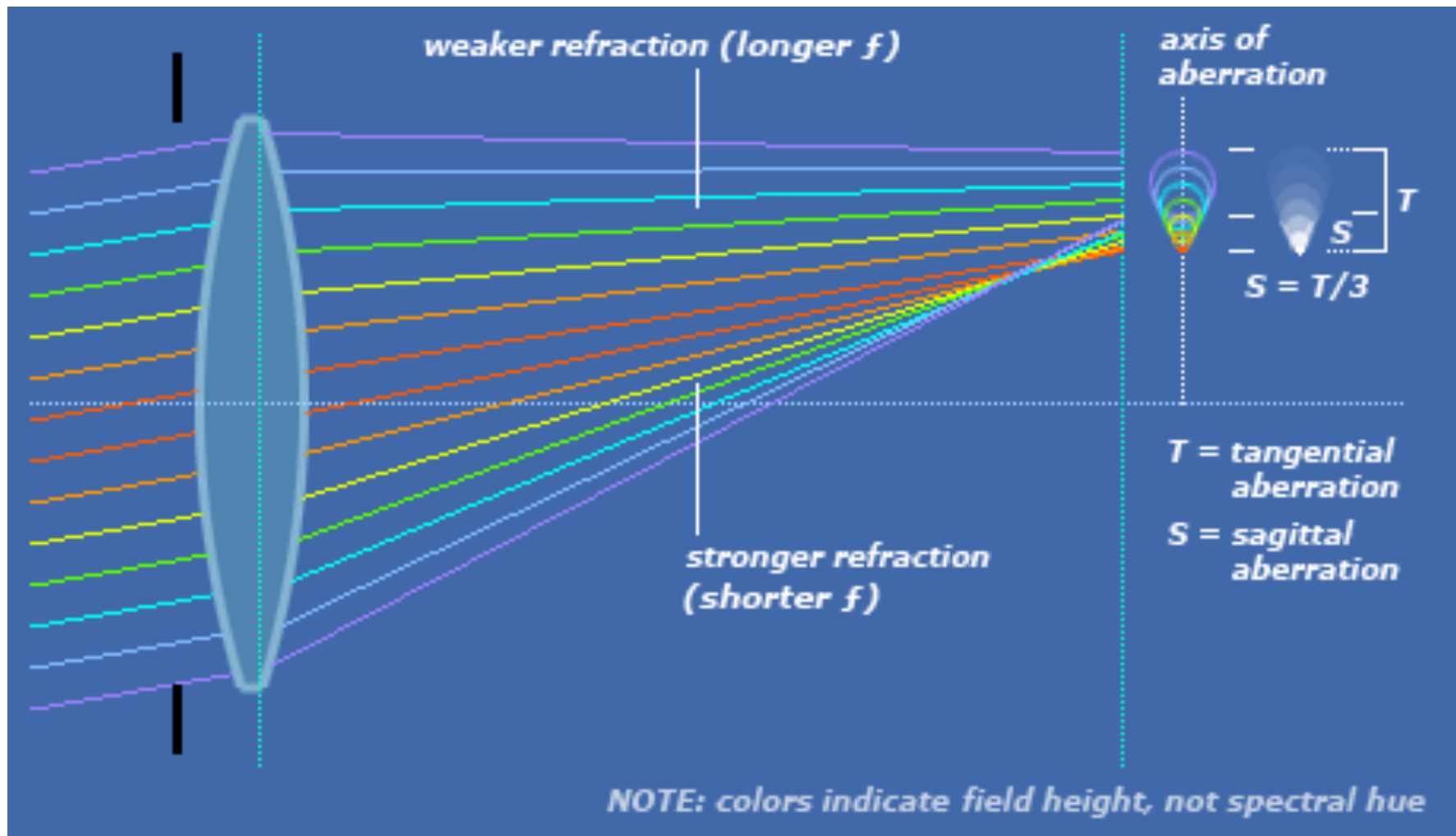

# Coma

---

- ◆ How can coma be reduced? Machine the lens surface to yet a different shape.
- ◆ An aspherical lens (purpose-shaped surfaces, not spherical but also not resembling any conic section) can reduce (but not completely eliminate) coma.

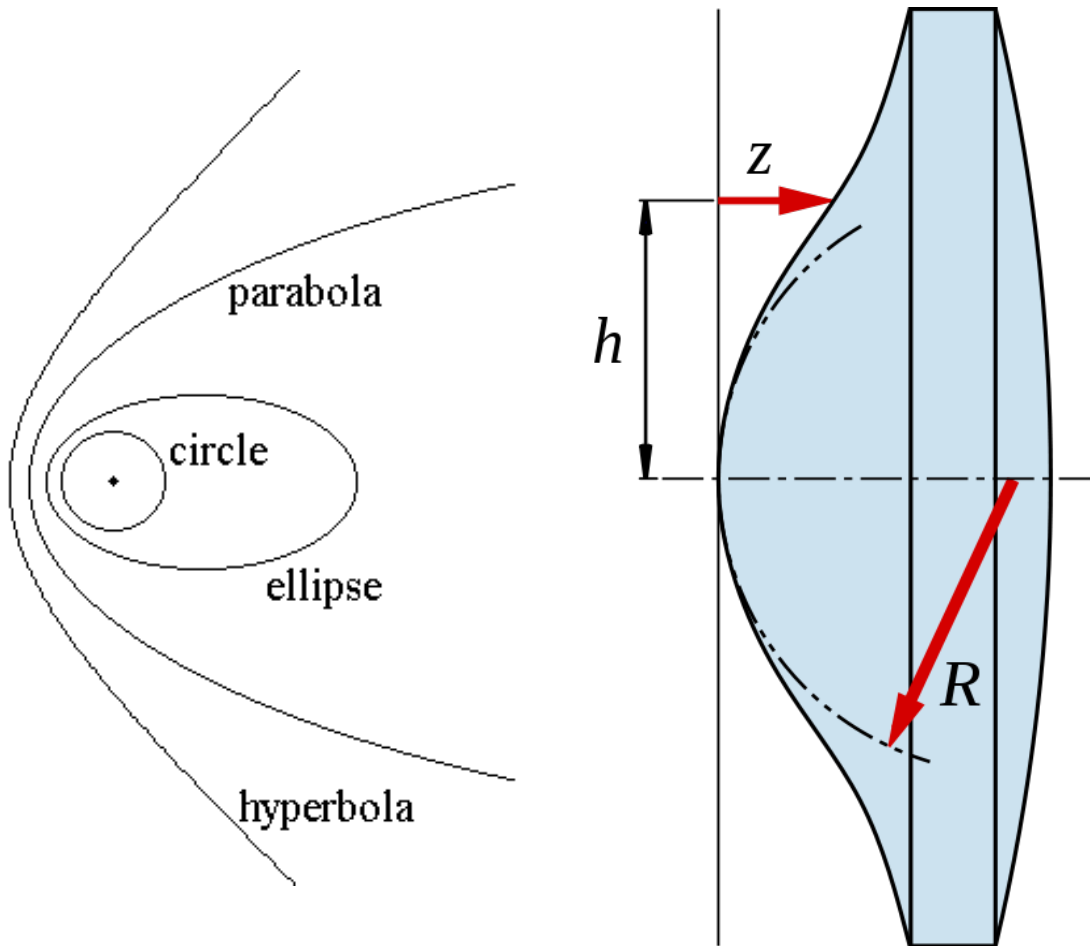

# Coma

---

- ◆ An aspherical lens can also eliminate spherical aberration.

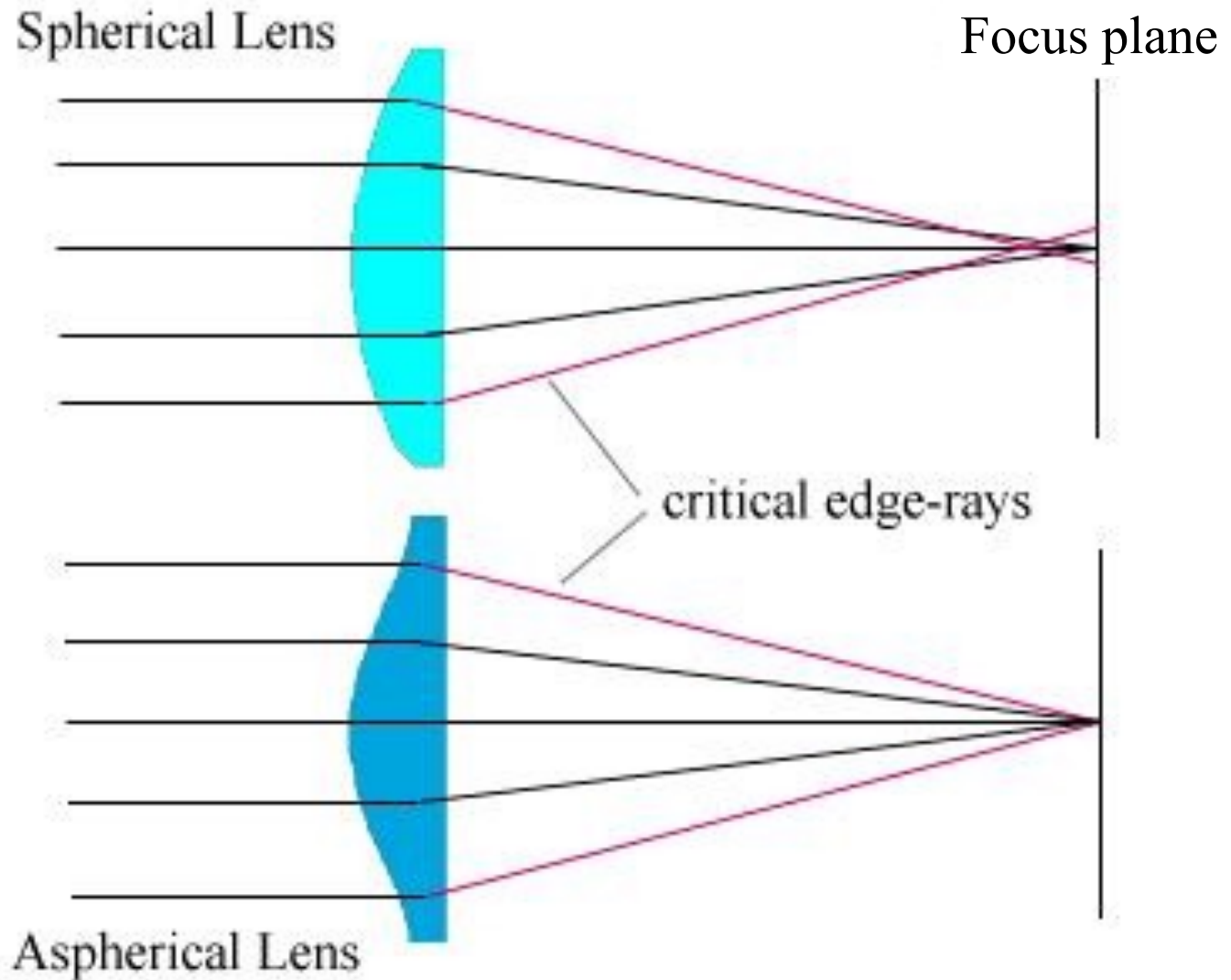

# Coma

---

- ◆ Light rays at an angle to and at different distances from the principal axis focus at different points along and at different heights above the principal axis. Comatic aberration happens even for parabolic surfaces.

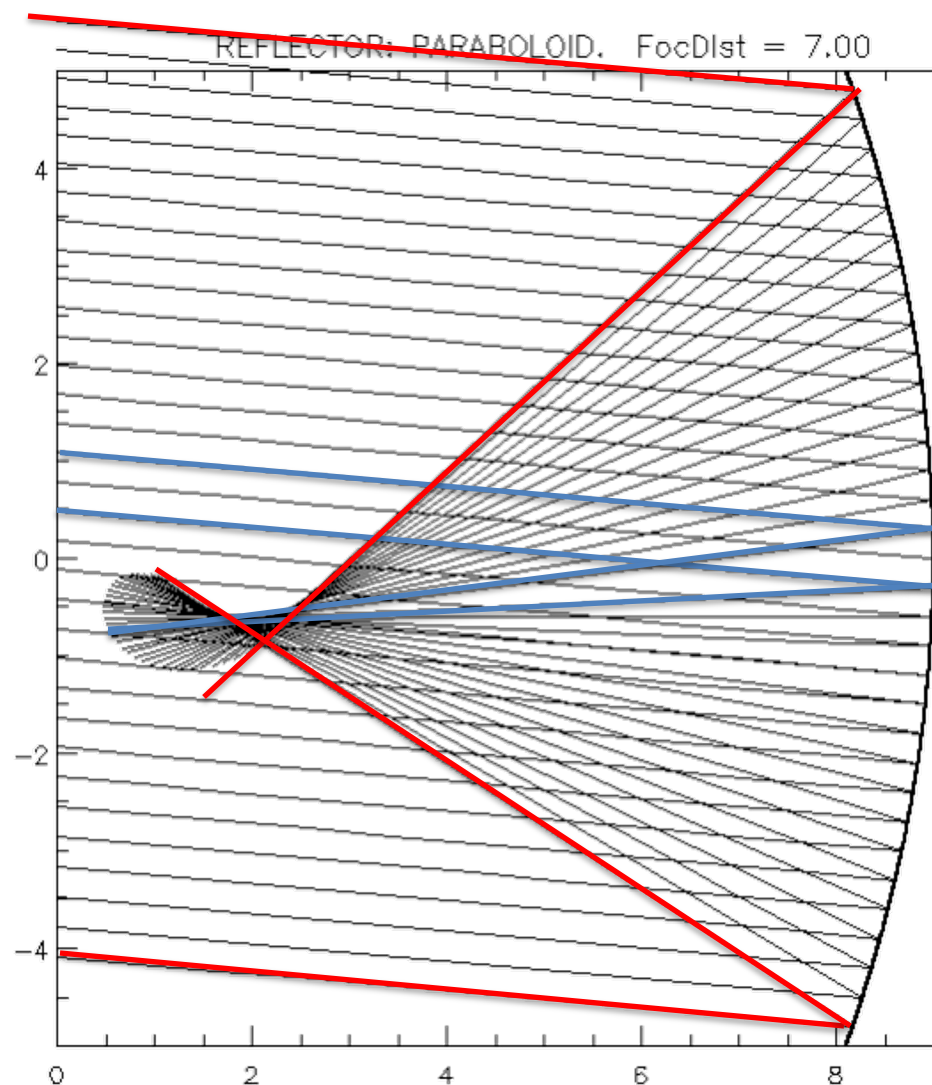

# Coma

---

- ◆ Light rays at an angle to and at different distances from the principal axis focus at different points along and at different heights above the principal axis. Comatic aberration happens even for parabolic surfaces.
- ◆ A screen placed at a location where light rays at a given distance from the principal axis is focused will not coincide with where light rays at a different distance from the principal axis is focused.
- ◆ How can coma be reduced?

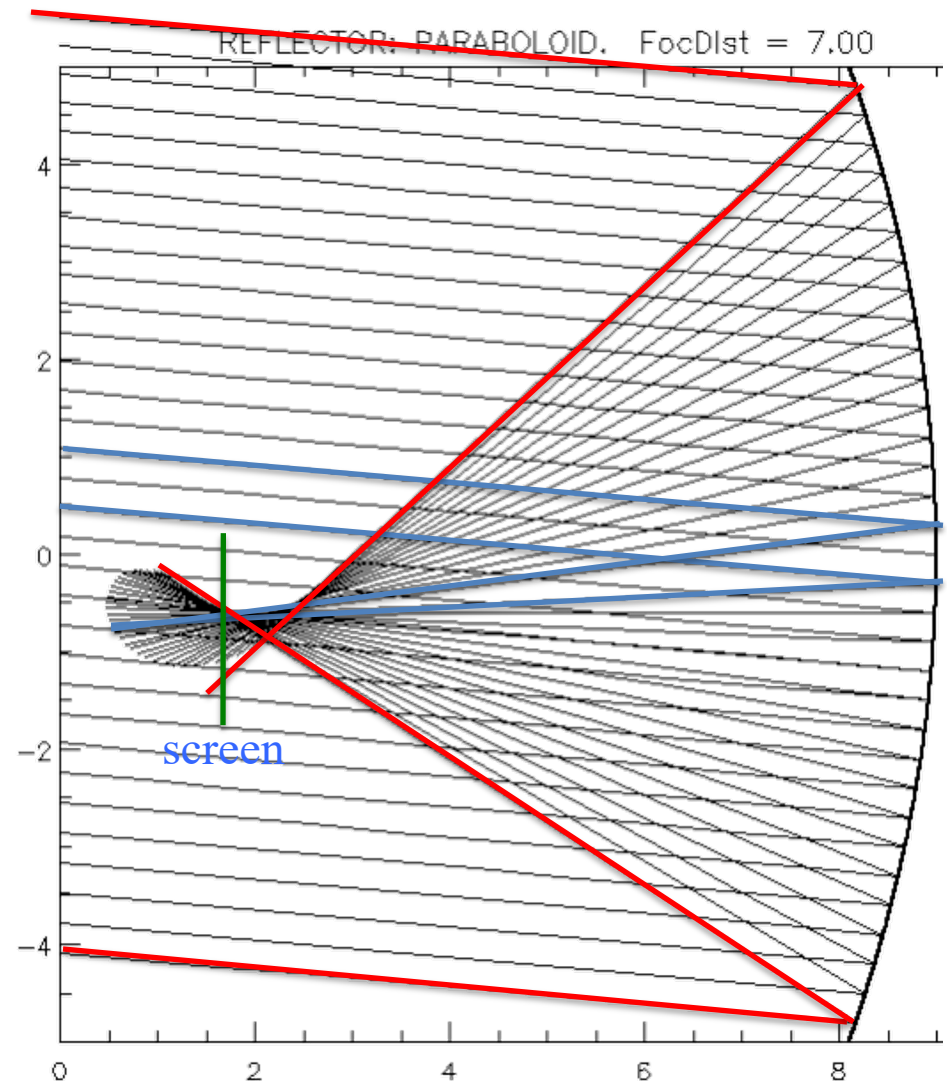



# Coma

- ◆ Change the shape of the mirror to a hyperbola. A hyperbolic mirror does not suffer from spherical aberration, and minimizes – but does not entirely eliminate – comatic aberration.

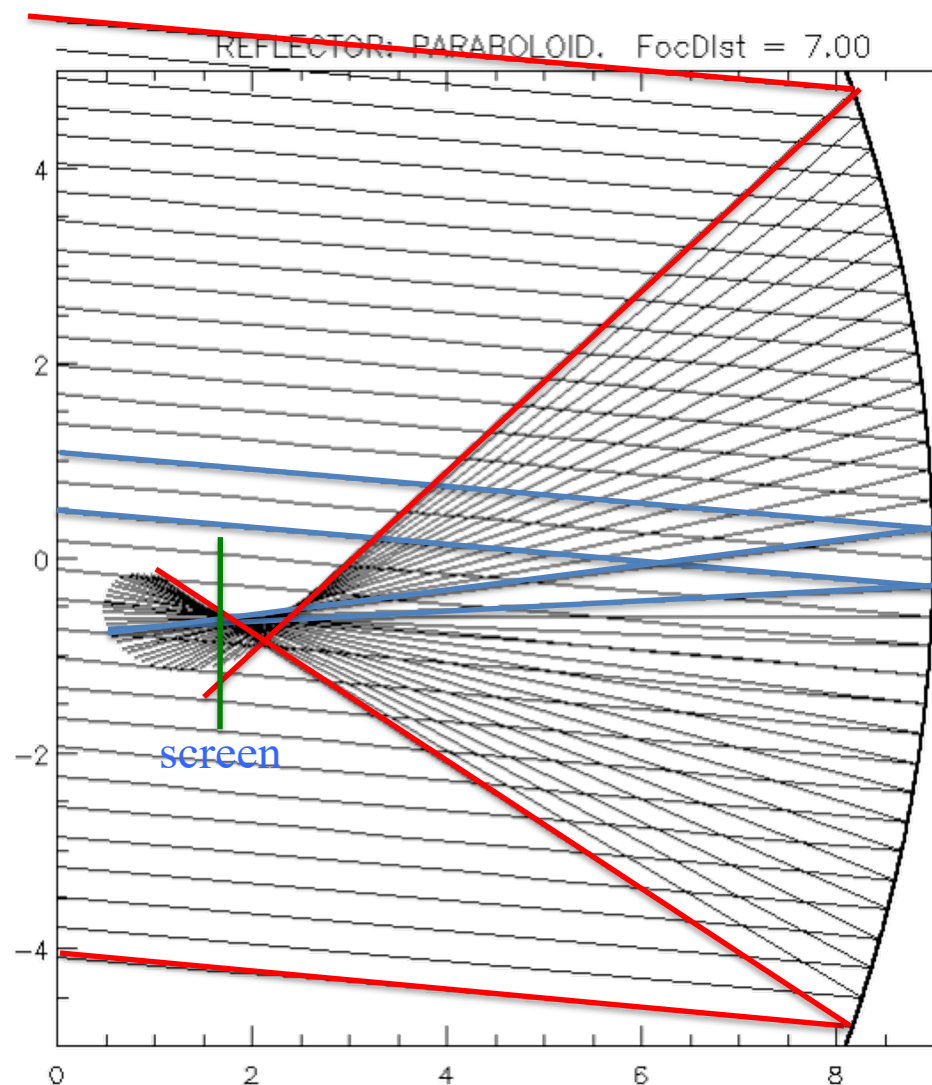
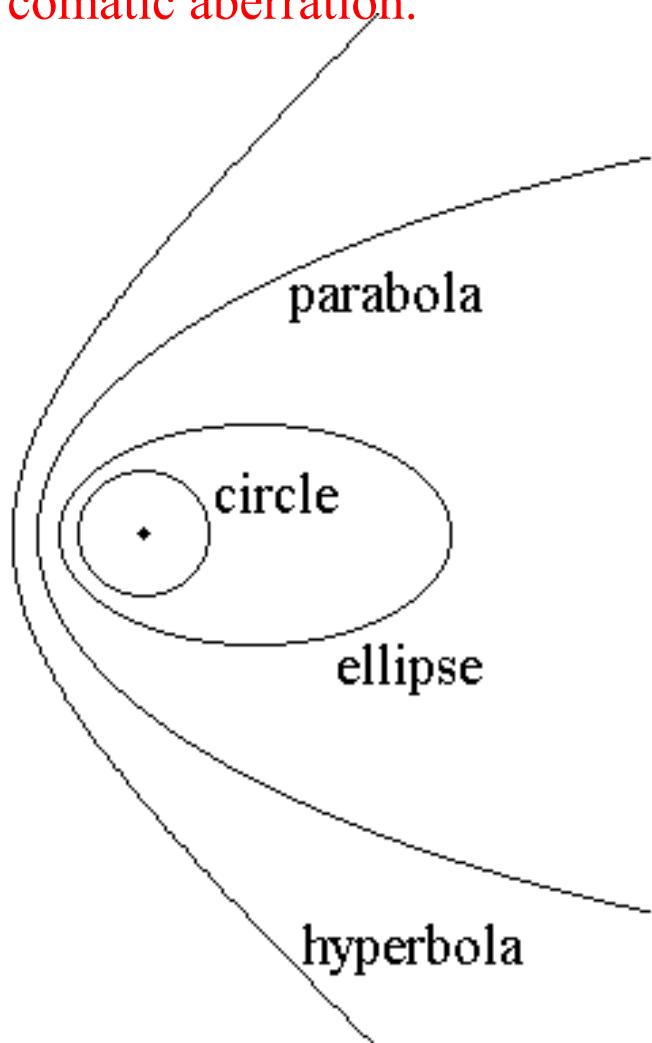

# Coma

---

- ◆ All modern reflecting telescopes employ hyperbolic (primary and secondary) mirrors, known as the Ritchey–Chrétien design after its inventors George Willis Ritchey and Henri Chrétien who came up with the idea in the early 1910s.

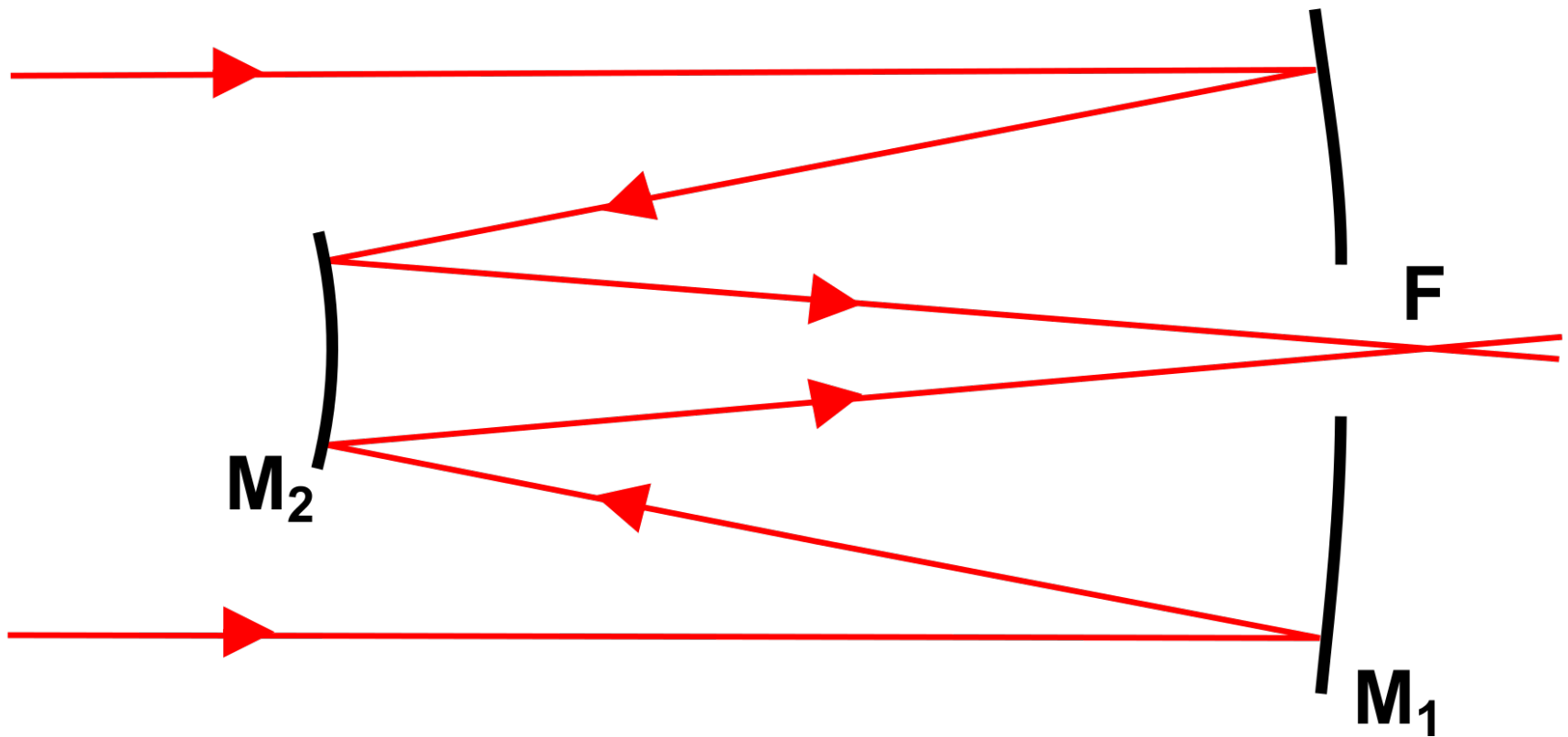

**Ritchey-Chrétien**

# Ritchey-Chretien telescopes

---



Camera lens



Keck Telescopes

## Keck Telescope Specifications

### Telescope

Optical design:	Ritchey-Chretien
Mount:	Altazimuth
Overall height:	24.6 meters
Total moving weight:	270 tons
Total weight of glass:	14.4 tons

### Primary mirror:

Design:	Actively controlled, segmented hexagon
Equivalent diameter:	10 meters
Figure:	Concave hyperboloid
Number of segments:	36
Segment diameter:	1.8 meters
Segment thickness:	75 mm
Segment weight:	400 kg
Gap between segments:	3 mm
Segment material:	Zerodur low-expansion glass-ceramic

Light collecting area:	76 square meters
Focal ratio:	f/1.75

# Field Curvature

---

- ◆ Light rays at increasingly larger angles to the principal axis do not focus in a plane but in a curved surface. By comparison, CCDs are manufactured with flat surfaces!

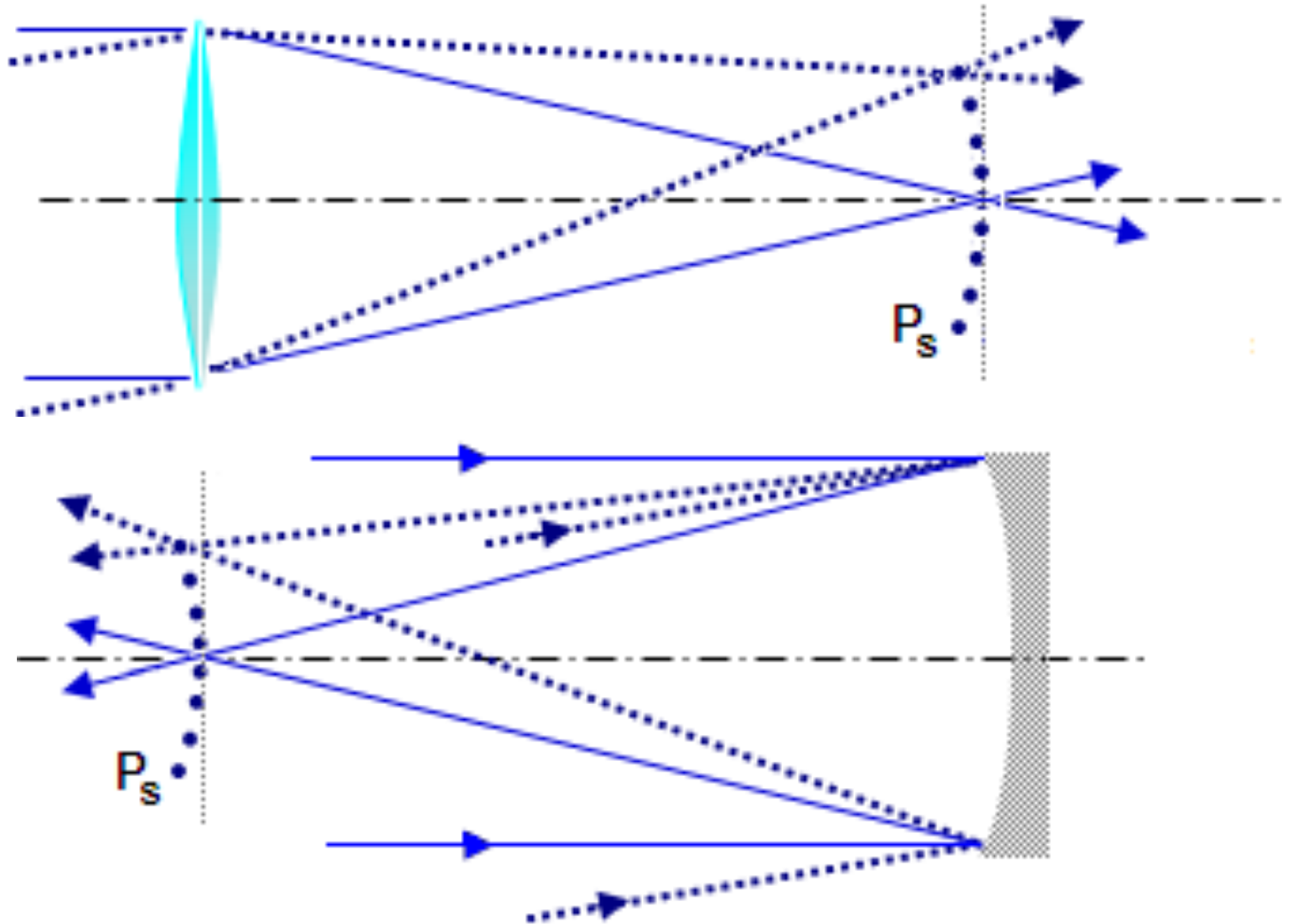

# Field Curvature

---

- ◆ Light rays at increasingly larger angles to the principal axis do not focus in a plane but in a curved surface. By comparison, CCDs are manufactured with flat surfaces!

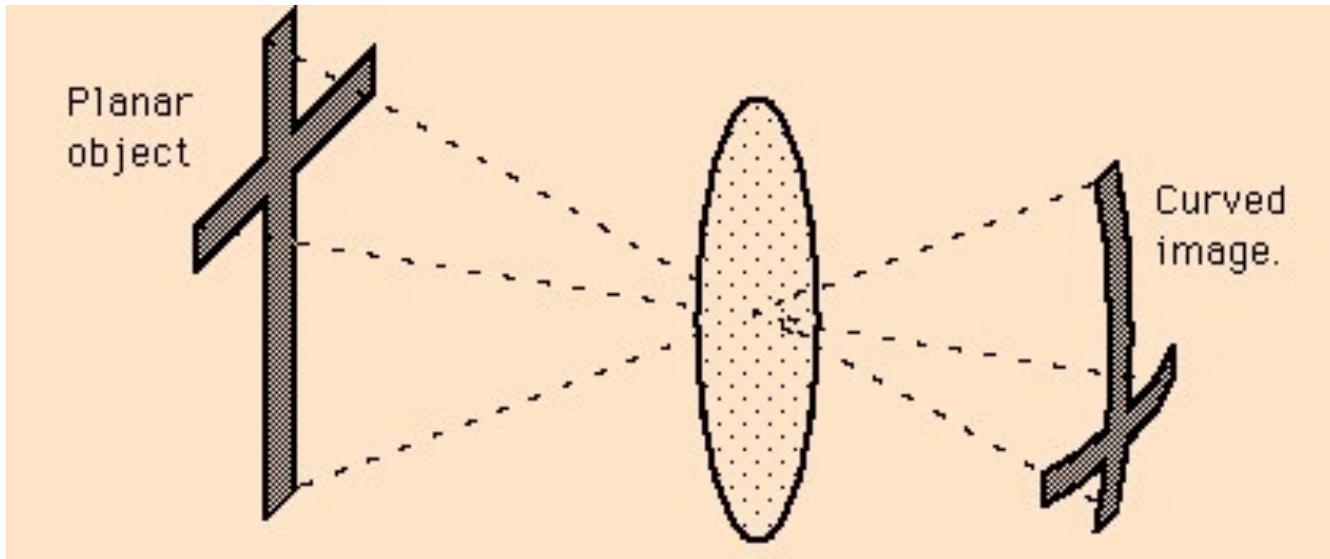
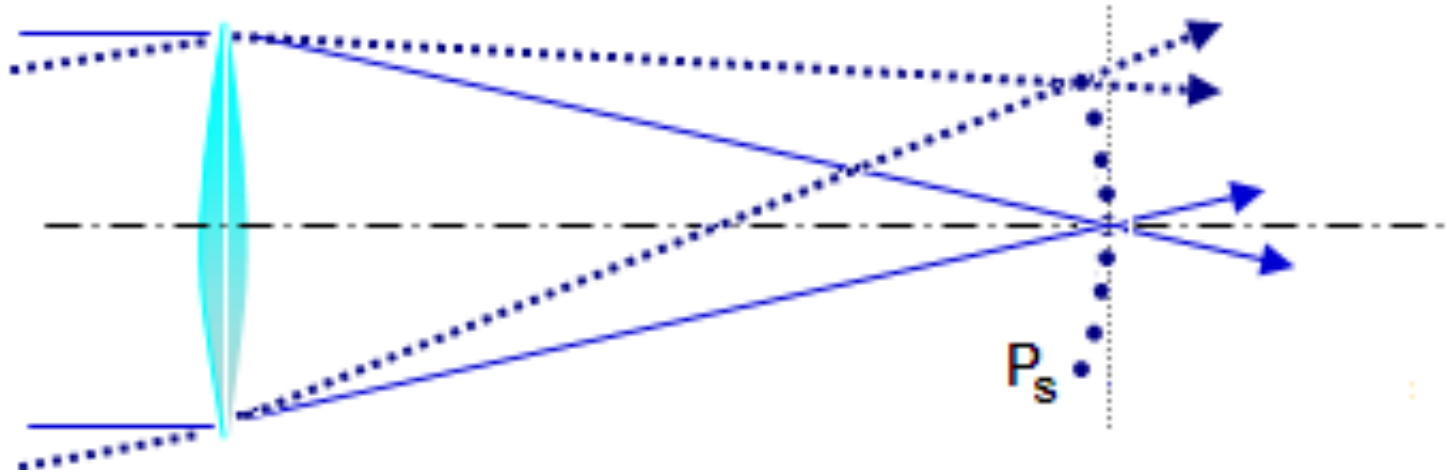

# Field Curvature

---

- ◆ Light rays at increasingly larger angles to the principal axis do not focus in a plane but in a curved surface. **How can field curvature be reduced?**

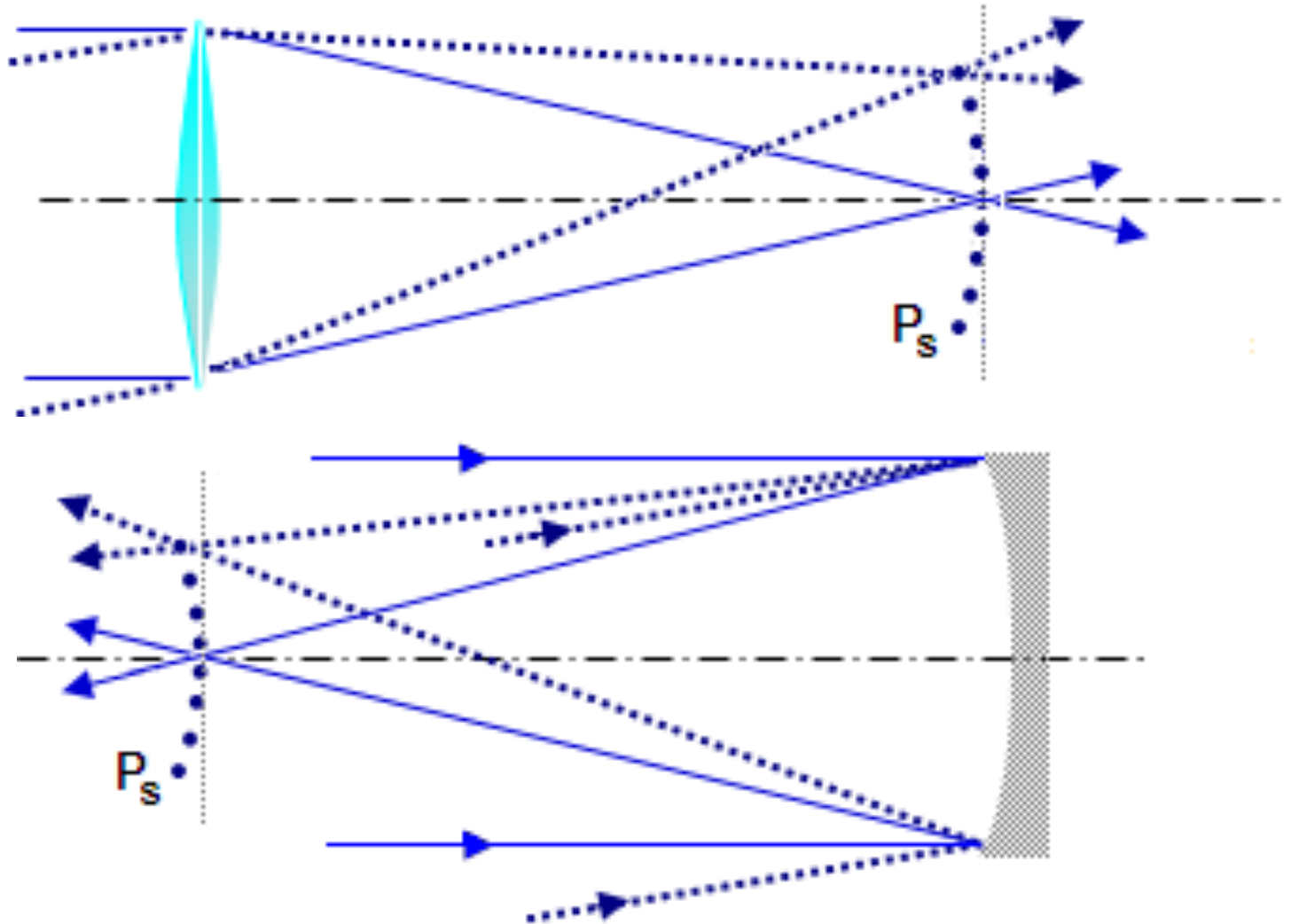

# Field Curvature

- ◆ Most current photographic lenses are designed to minimize field curvature, and so effectively have a focal length that increases with ray angle. Such lenses can be very complicated (comprising many individual lenses) and expensive.

## Objective Correction for Field Curvature

**Achromat**

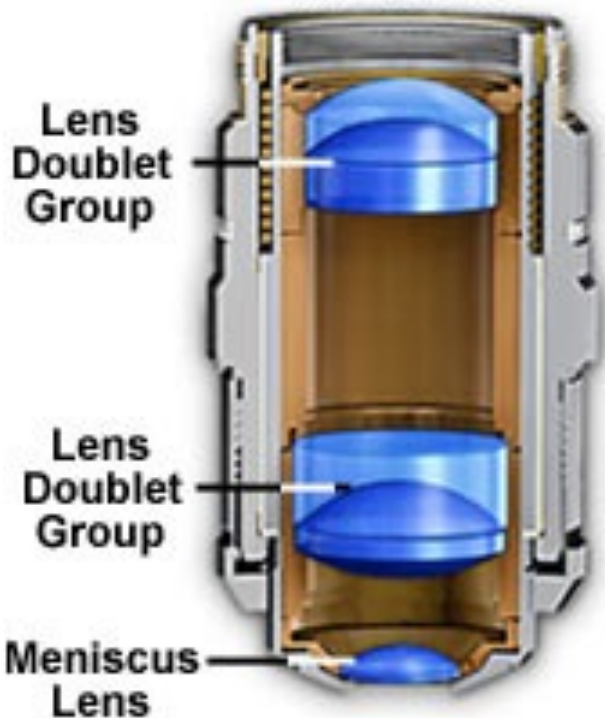

**Plan Achromat**

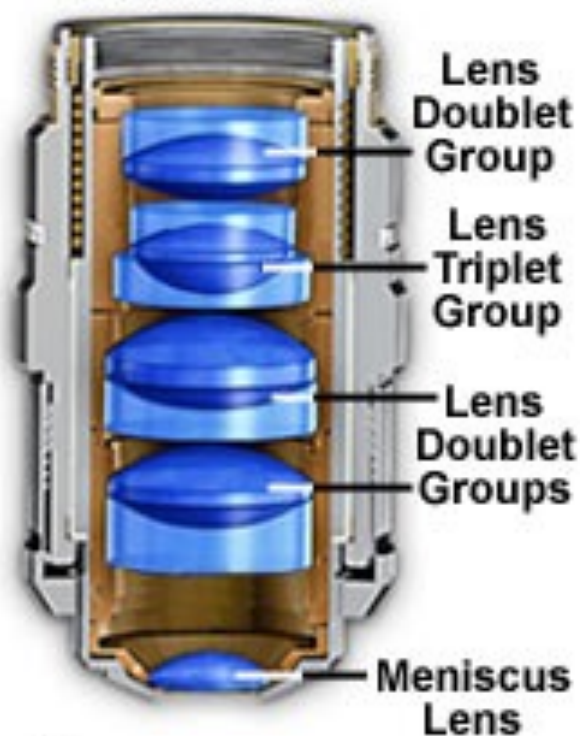

# Field Curvature

---

- ◆ CCDs cannot be bent, although large CCD mosaics can be shaped to simulate a curved surface such as the CCD mosaic used in the Kepler space telescope.

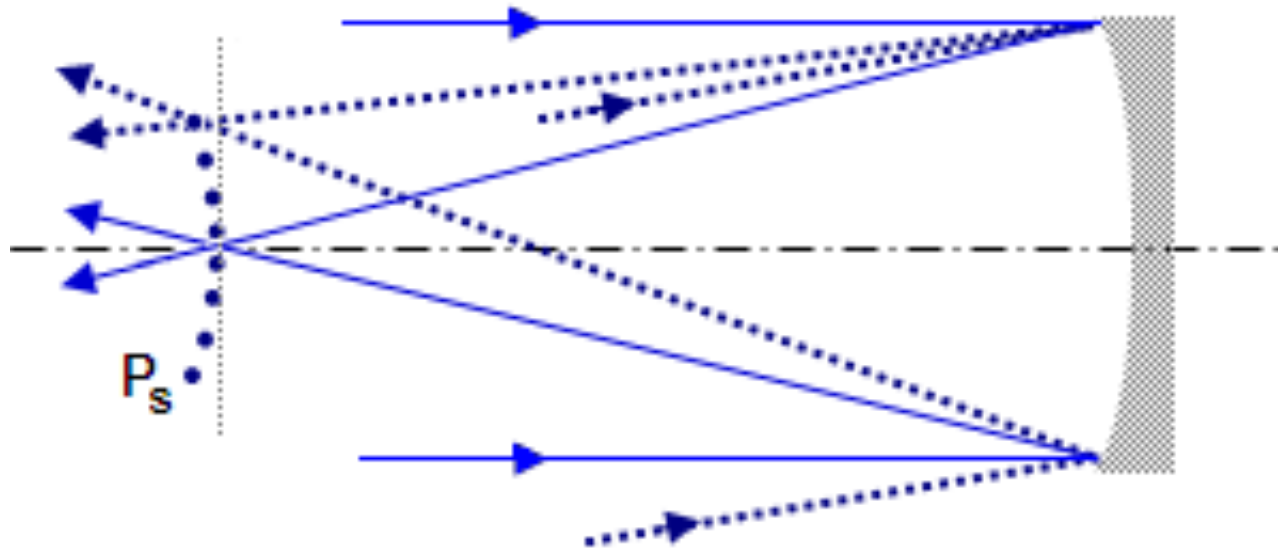
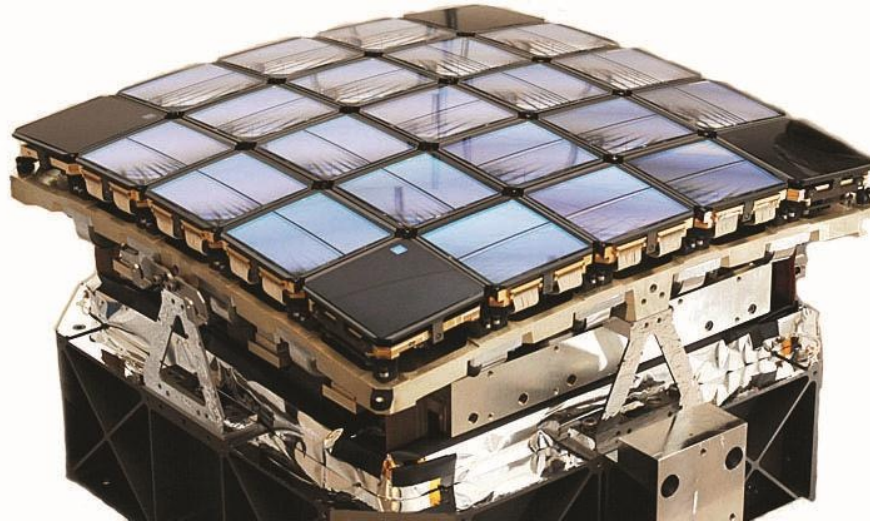



# Astigmatism

- ◆ So far, we have only considered light rays along a single plane (paper/board).

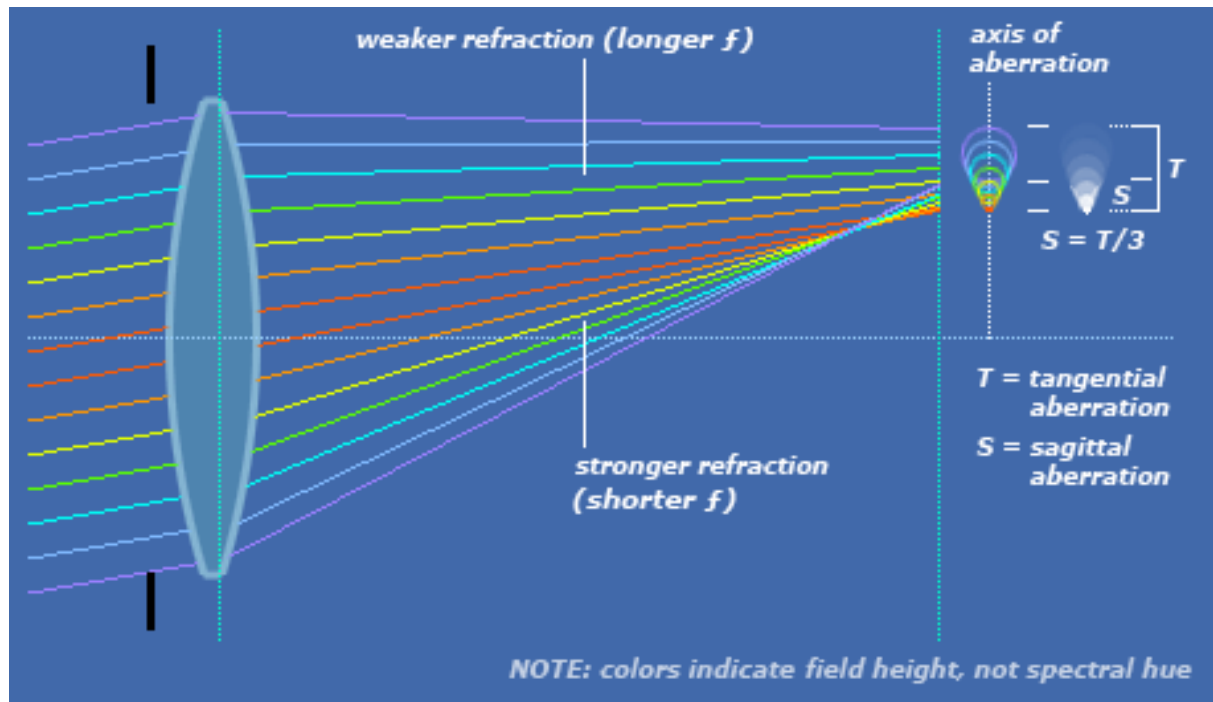
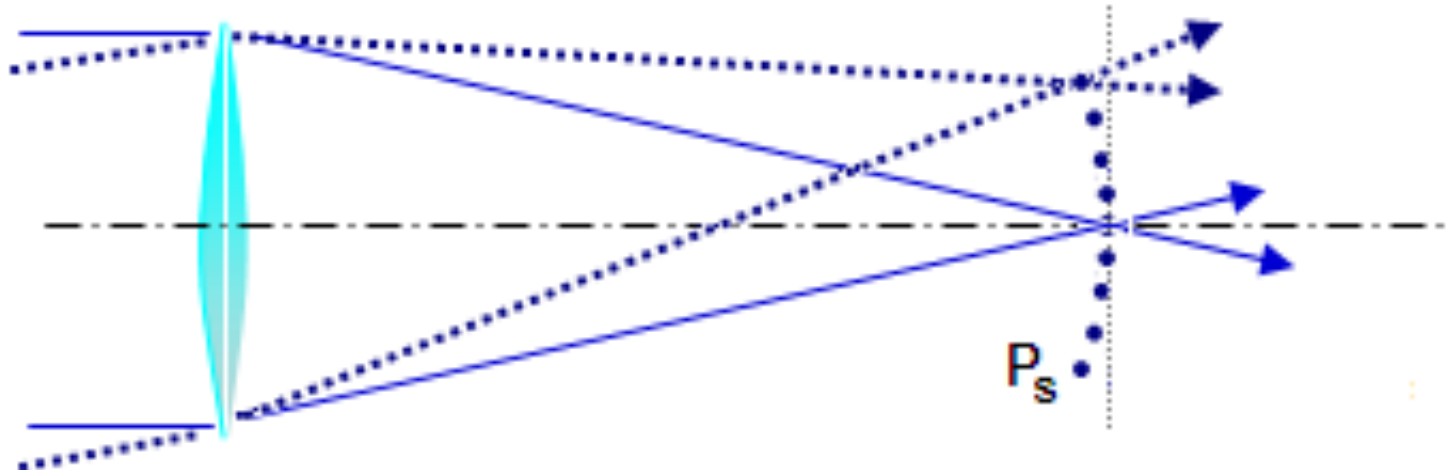

# Astigmatism

---

- ◆ For incident light rays at a given angle to the principal axis, a non-spherical lens is foreshortened differently for light in different planes and therefore do not present a symmetric front. Light in different planes focus at different positions.

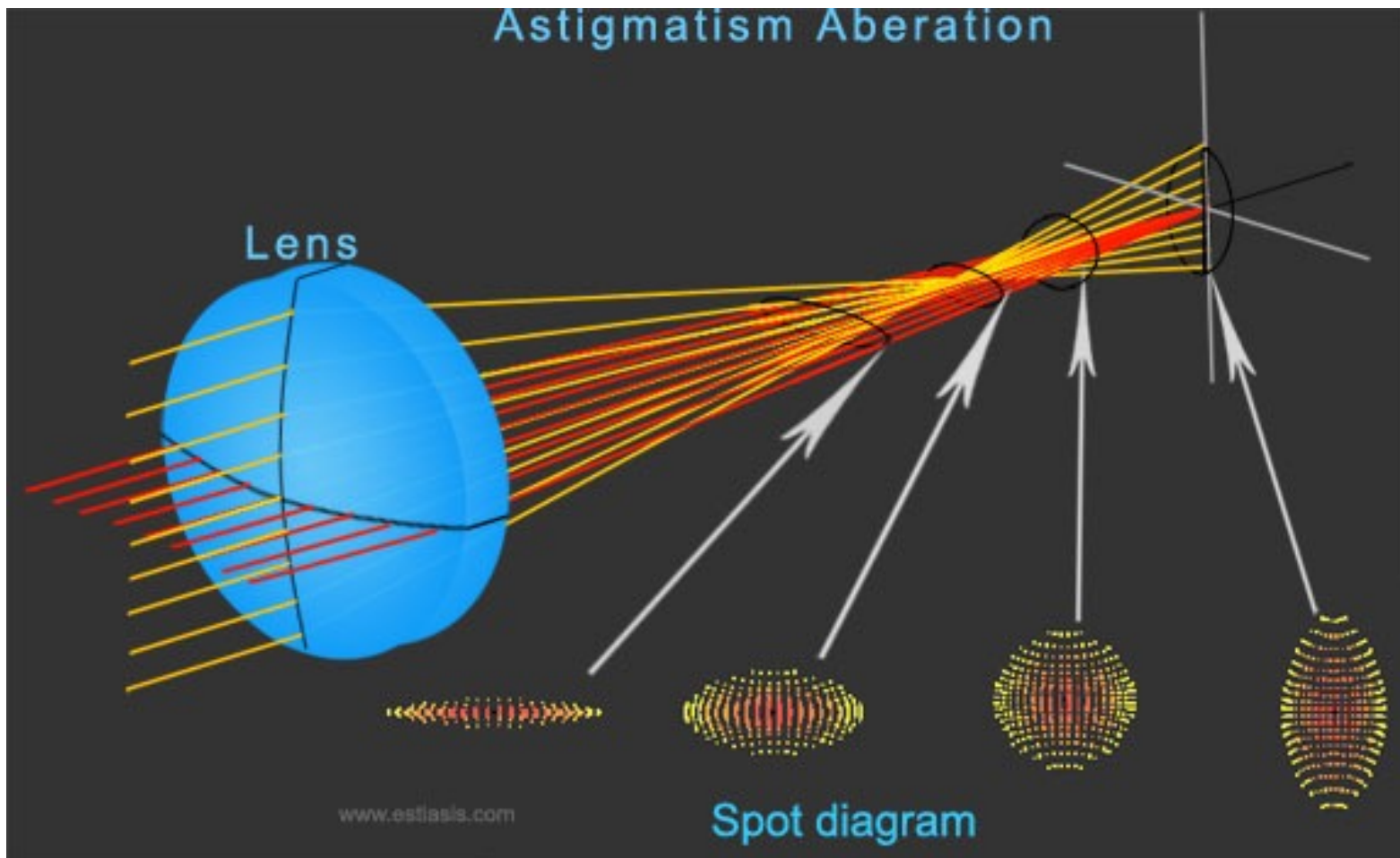

# Astigmatism

---

- ◆ Given that there is no common focus, where would you choose to project the image?

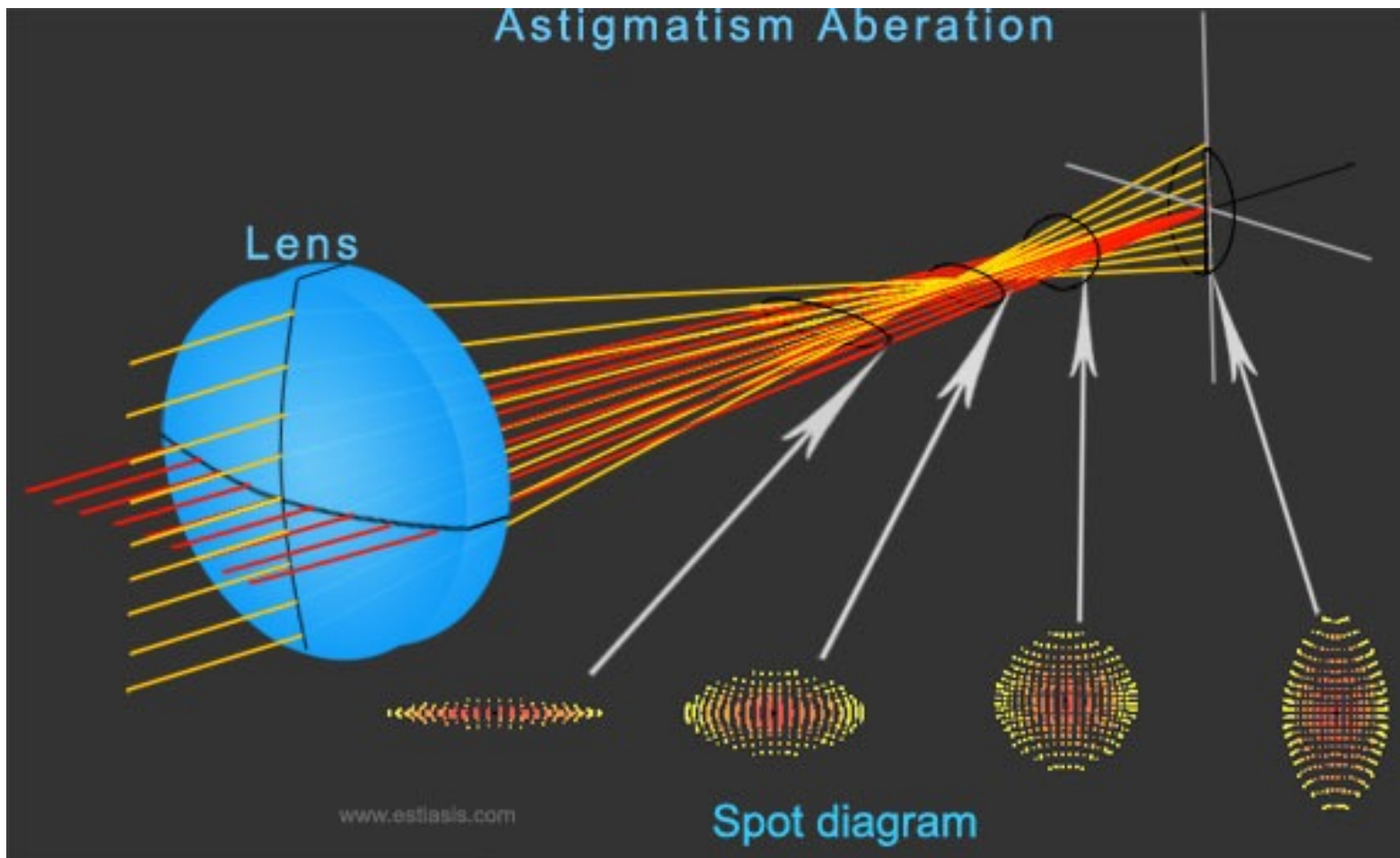

# Astigmatism

---

- ◆ Given that there is no common focus, where would you choose to project the image? Where the image is circular, also known as the circle of least confusion. Note, however, that the circle of least confusion lies along different planes for incident light rays at different angles to the principal axis.

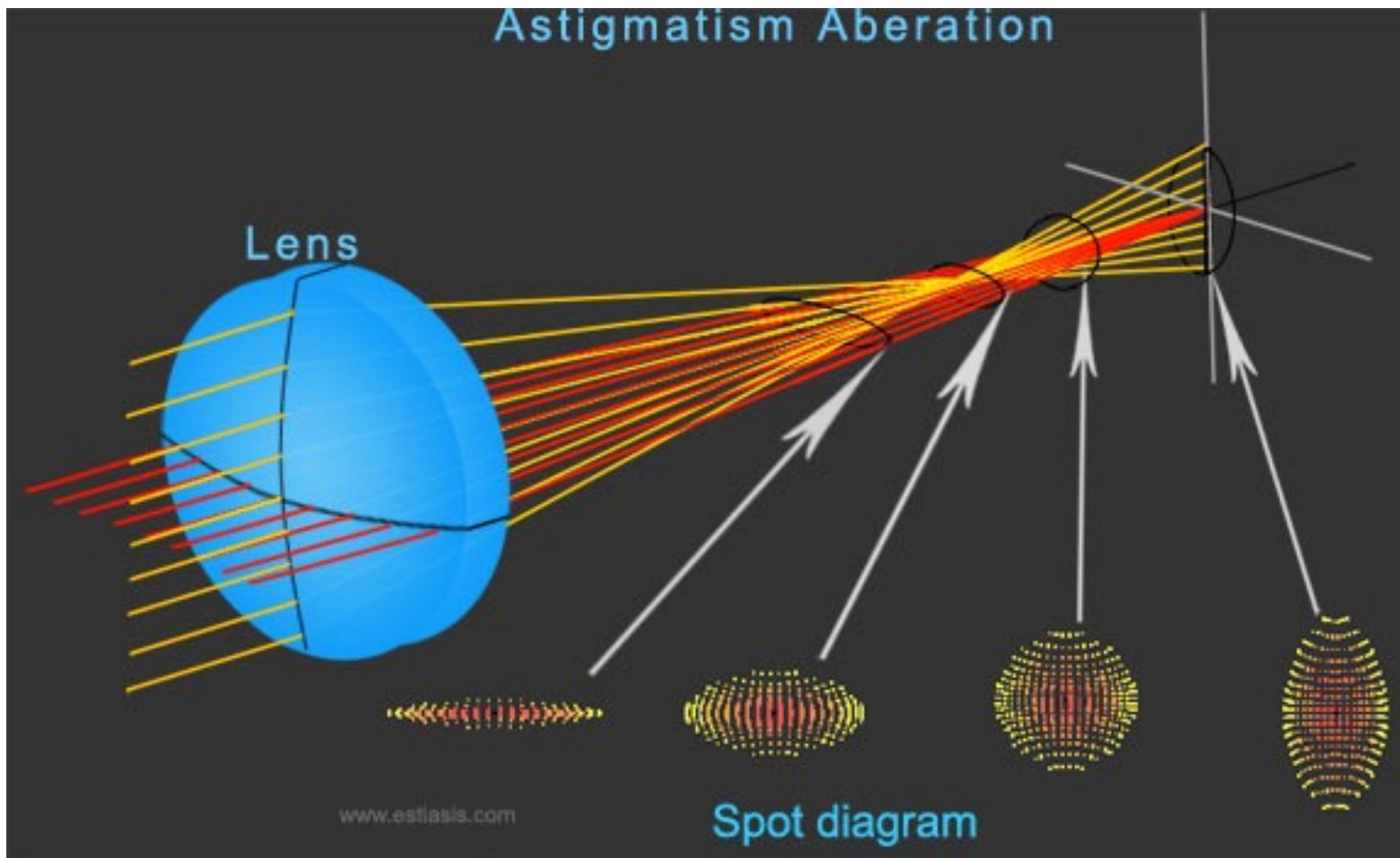

# Astigmatism

---

- ◆ Ritchey–Chrétien designs suffer from astigmatism.
- ◆ Why bother correcting for coma if images suffer from astigmatism?

Coma



Astigmatism

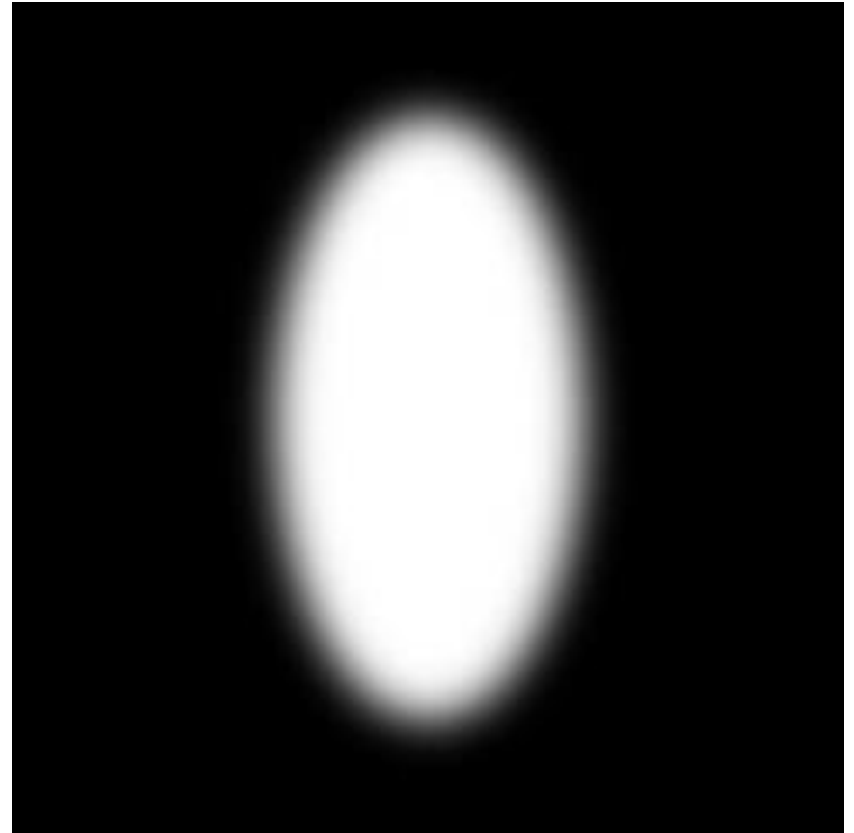

# Astigmatism

---

- ◆ Ritchey–Chrétien designs suffer from astigmatism.
- ◆ Why bother correcting for coma if images suffer from astigmatism? Important if you want to make precise positional measurements for the purpose of astrometry or to compare with images at other wavelengths.

Coma



Astigmatism

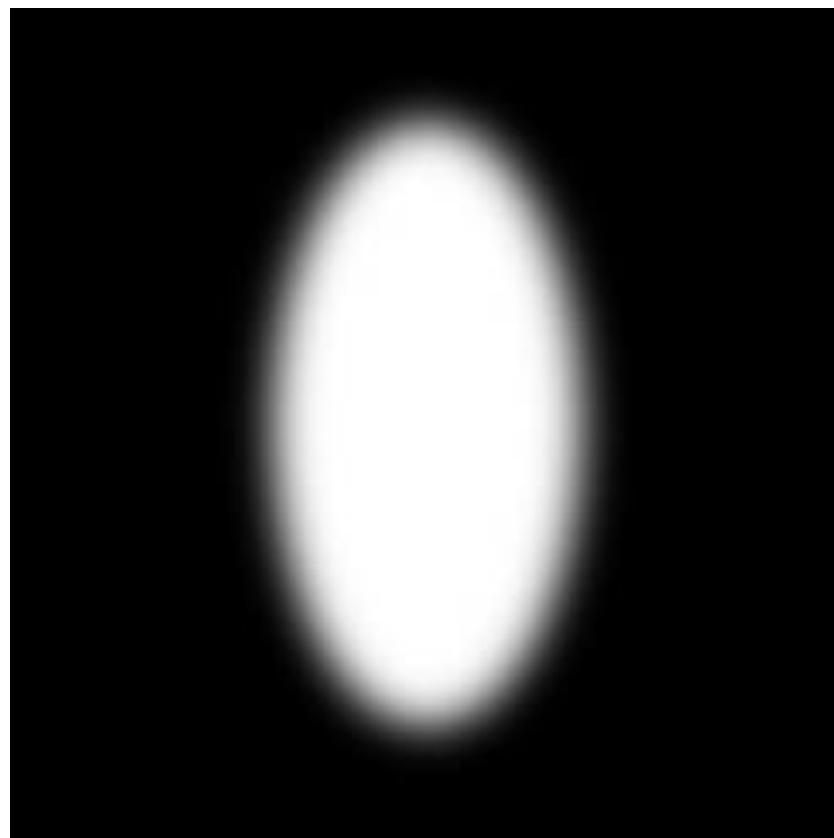

# Distortion

---

- ◆ Distortion arises from a difference in magnification across a field of view.

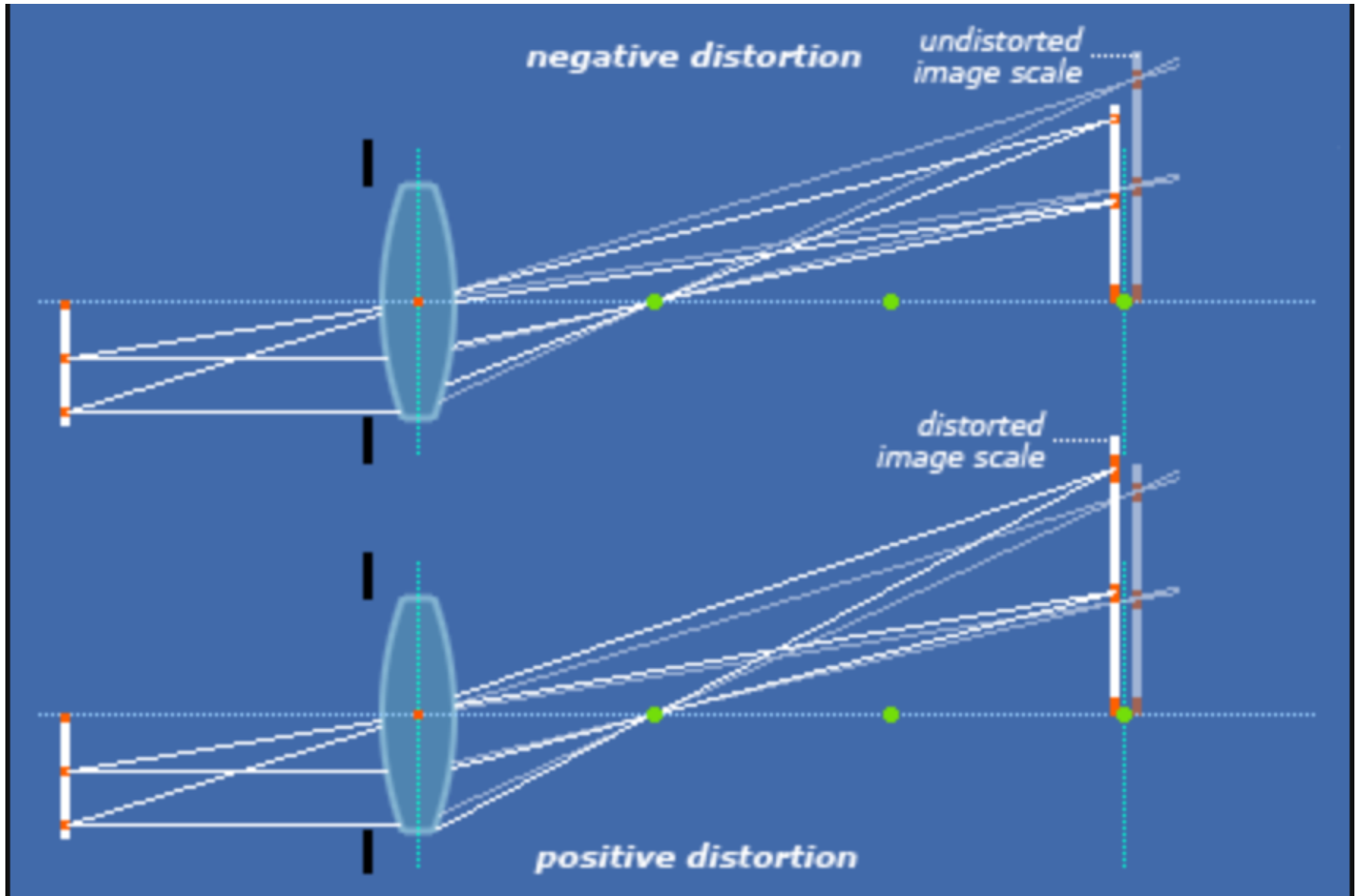

# Distortion

---

- ◆ If the magnification decreases radially outwards (negative distortion), the center of the image appears to bulge outward. This is called barrel distortion.
- ◆ If the magnification increases radially outwards (positive distortion), the corners of an image appear to bend outward. This is called pincushion distortion.

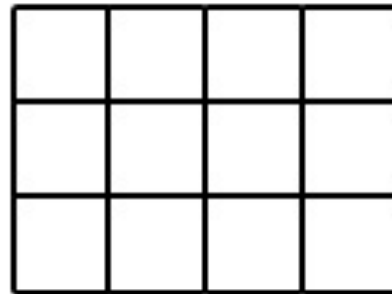

**No Distortion**



**Barrel Distortion**



**Pincushion Distortion**



# Distortion

---

- ◆ If the magnification decreases radially outwards, the center of the image appears to bulge outward. This is called barrel distortion.

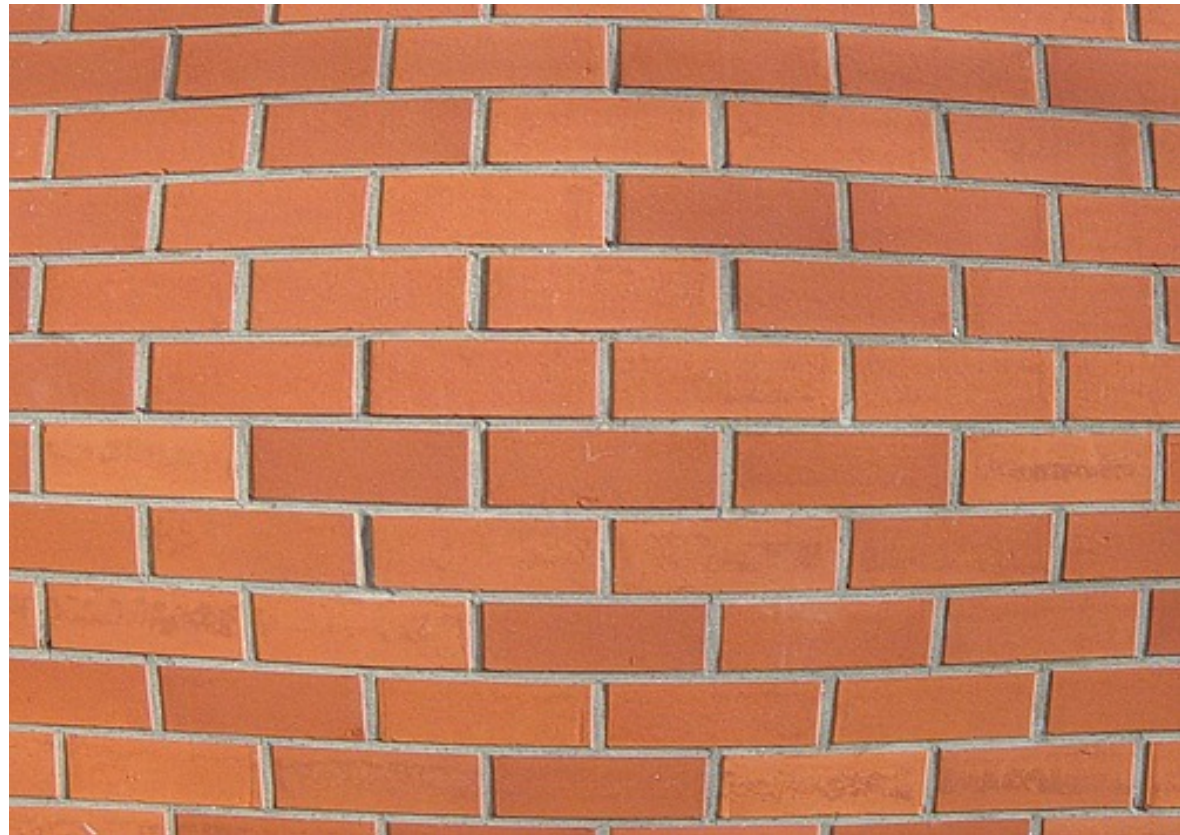

# Distortion

---

- ◆ If the magnification decreases radially outwards, the center of the image appears to bulge outward. This is called barrel distortion.



# Distortion

---

- ◆ If the magnification decreases radially outwards, the center of the image appears to bulge outward. This is called barrel distortion.



# Distortion

---

- ◆ If the magnification increases radially outwards, the corners of an image appear to bend outward. This is called pincushion distortion.



**Pincushion Distortion**



# Distortion

---

- ◆ If the magnification increases radially outwards, the corners of an image appear to bend outward. This is called pincushion distortion.



**Pincushion Distortion**

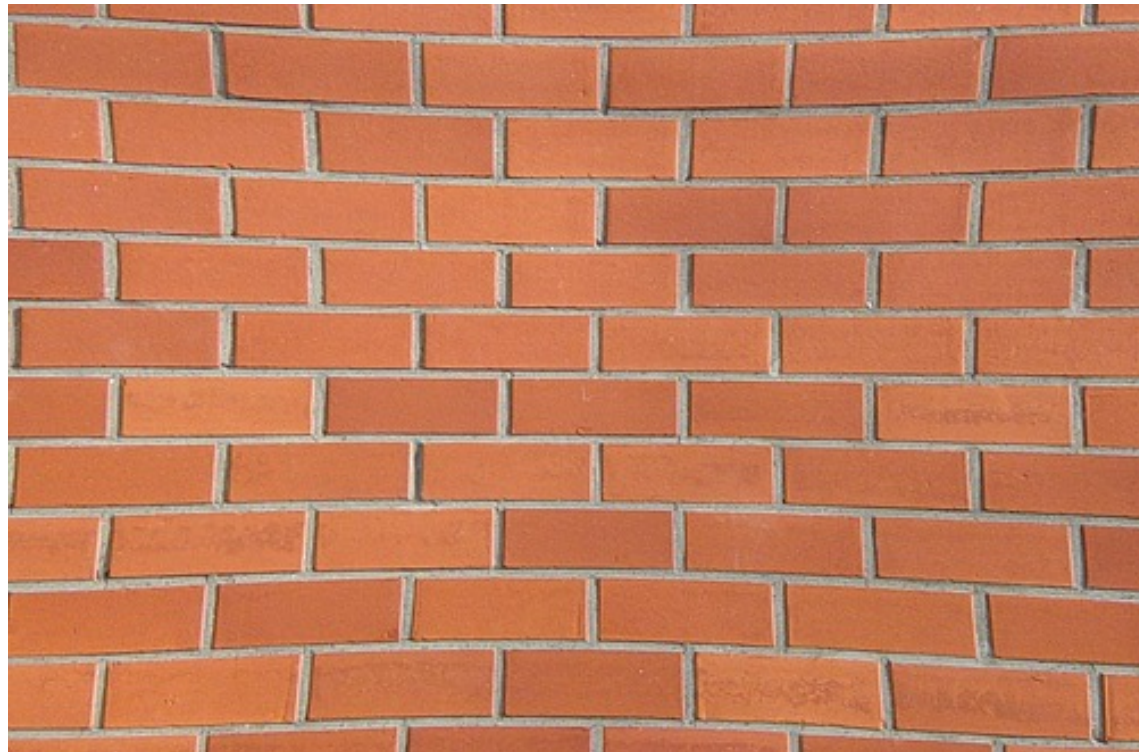

# Distortion

---

- ◆ If the magnification increases radially outwards, the corners of an image appear to bend outward. This is called pincushion distortion.



**Pincushion Distortion**



# Distortion

---

- ◆ Distortion is usually problematic only when the field of view is large. More and more telescopes in professional use, however, are being used to image wide fields.
- ◆ Pictures taken with the same telescope but having slightly different field centers. Notice that separations between the same objects are different in the two frames.

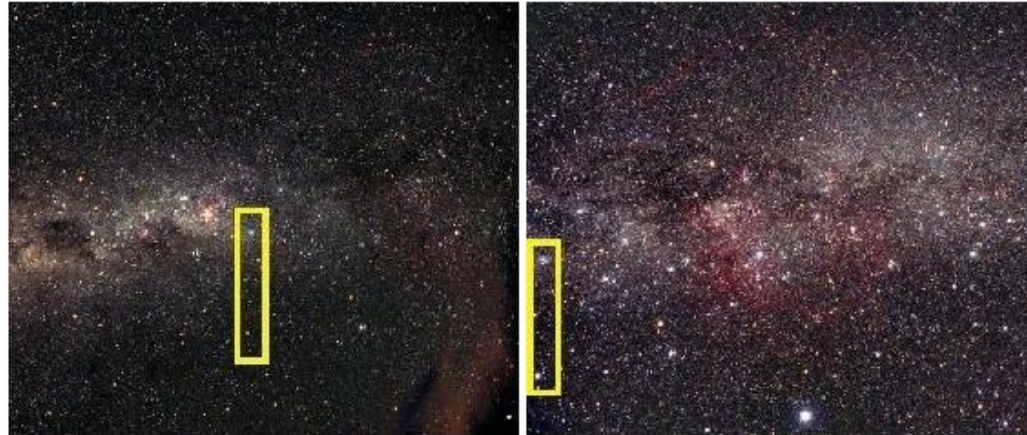

# Chromatic Aberration

---

- ◆ Recall Snell's law for refraction, where  $n_1$  and  $n_2$  are the index of refraction of the two media:

$$n_1 \sin \theta_1 = n_2 \sin \theta_2$$

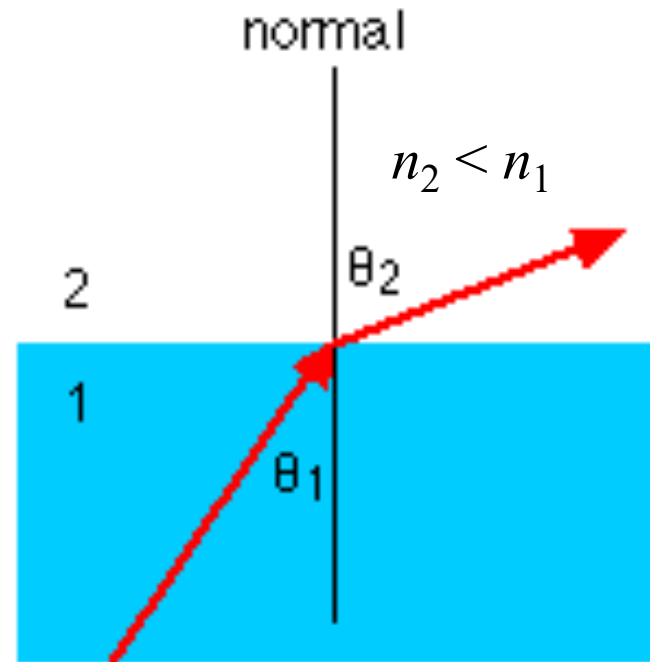
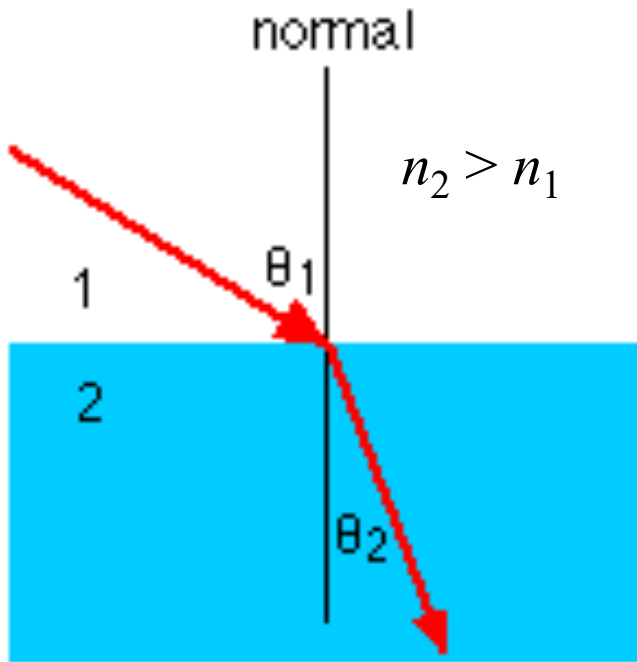



# Chromatic Aberration

- ◆ Index of refraction for most transparent materials are wavelength dependent, i.e.  $n$  is a function of  $\lambda$ .
- ◆ As a consequence, the angle of refraction,  $\theta_2$ , depends on  $\lambda$ .

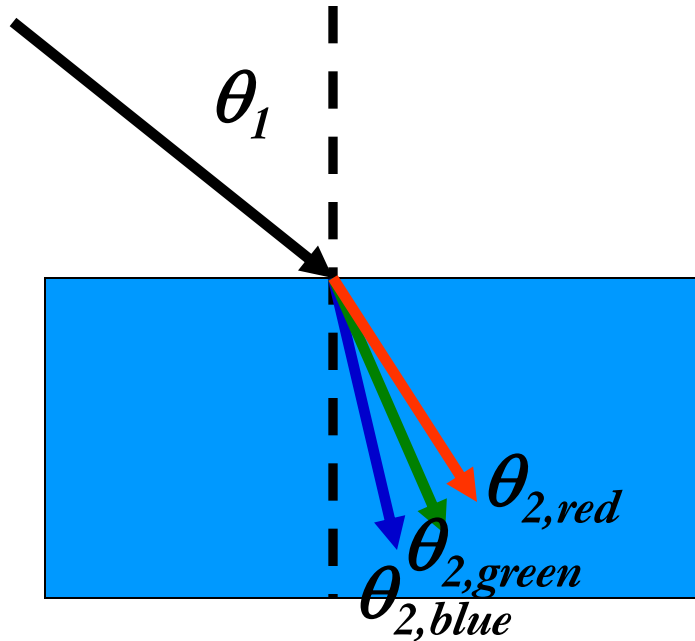

$$\theta_{2,blue} < \theta_{2,green} < \theta_{2,red} < \theta_1$$

$$n_{blue} > n_{green} > n_{red} > n_{air}$$

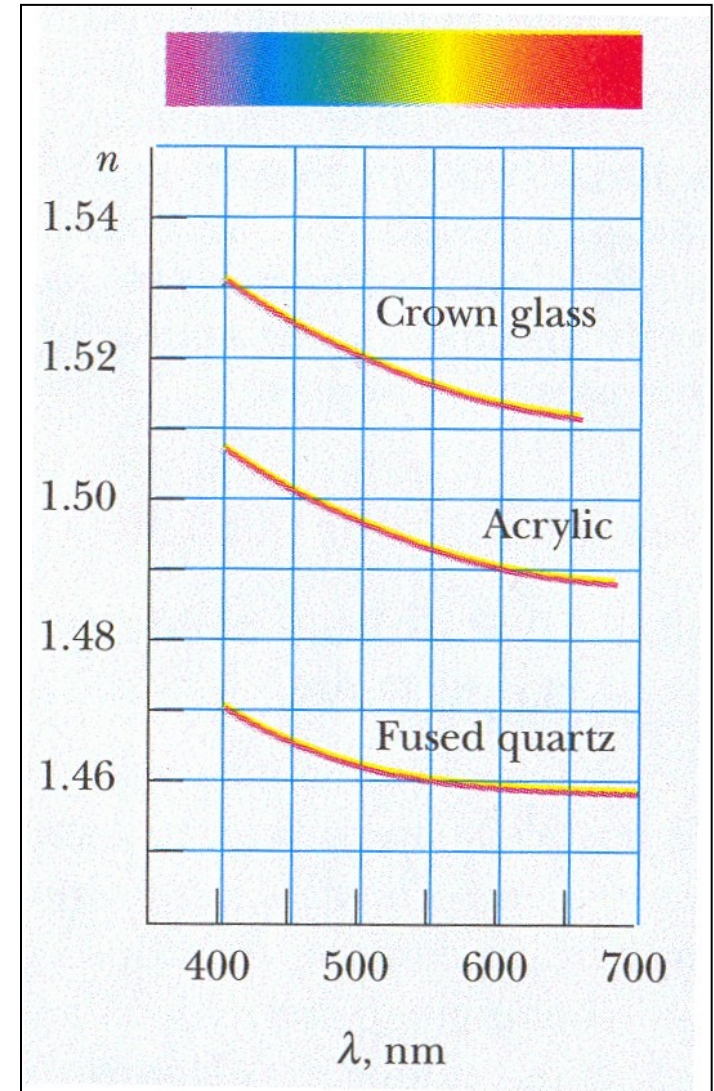

# Chromatic Aberration

---

- ◆ Light rays from the same direction but at different wavelengths focus at different points, an effect known as chromatic aberration.
- ◆ One way to reduce chromatic aberration is to use a lens with a long focal length.

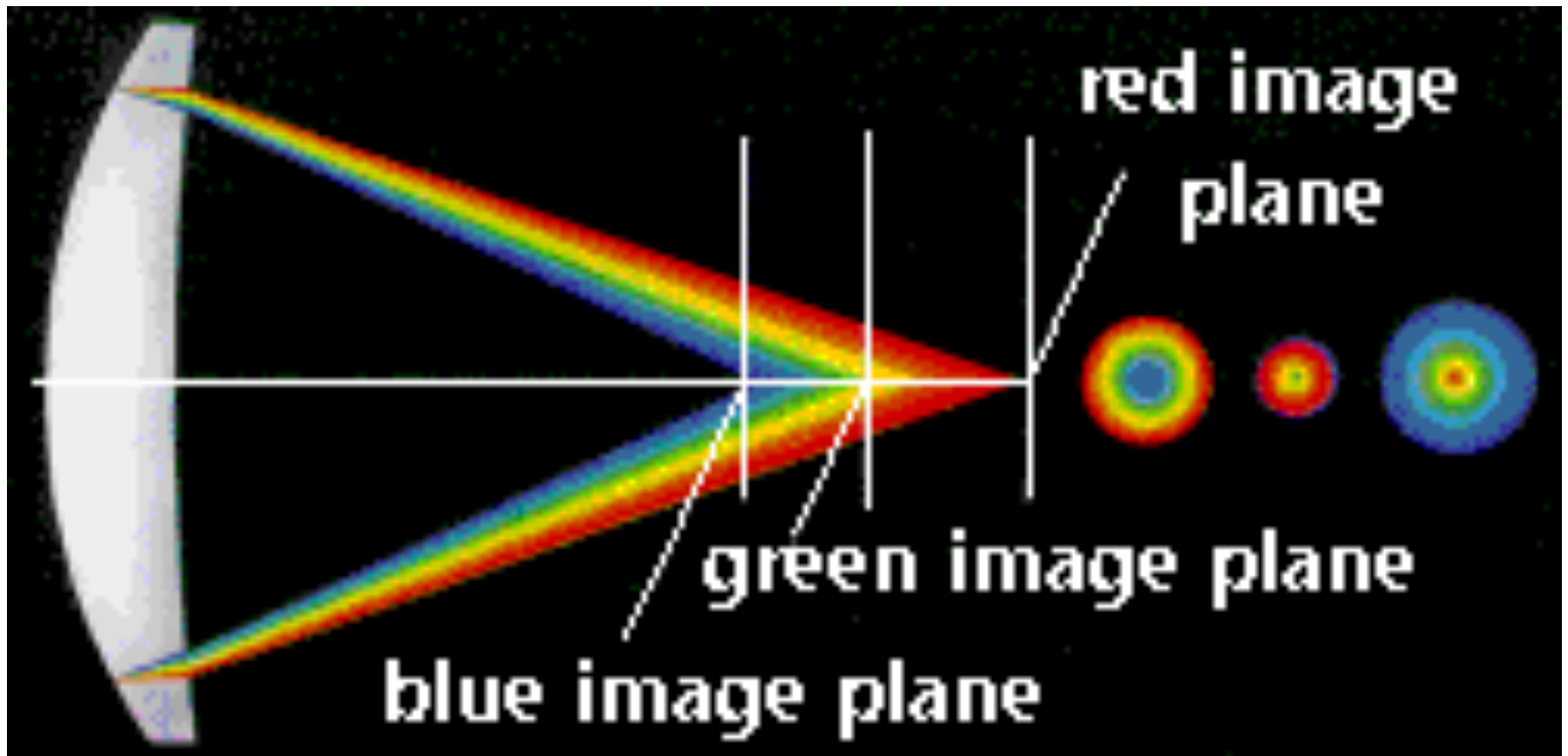

# Chromatic Aberration

---

- ◆ In the picture below, chromatic aberration most apparent at sharp edges.



# Chromatic Aberration

---

- ◆ An achromatic lens (objective and eyepiece), most commonly comprising two individual lenses with different dependences of  $n$  with  $\lambda$ , brings two wavelengths (typically red and blue) into focus in the same plane.

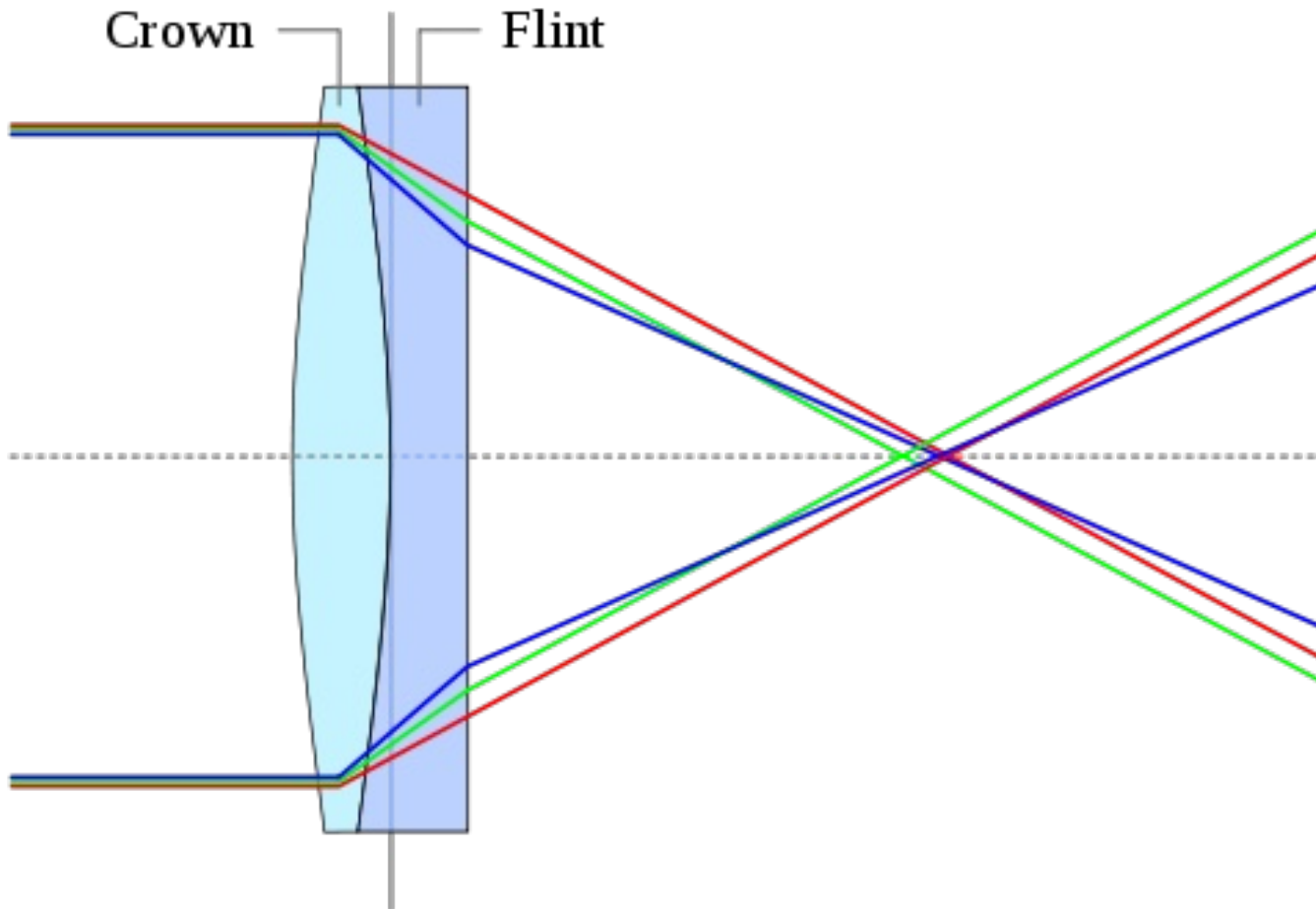

# Chromatic Aberration

---

- ◆ Recall the picture of the 1.02-m Yerkes telescope shown at the start of this chapter? It is a  $f/19$  telescope, and therefore has a focal length of 19.0 m, and uses an achromatic lens, both employed so as to reduce chromatic aberration.



# Chromatic Aberration

---

- ◆ Law of reflection: angle of reflection ( $r$ ) = angle of incidence ( $i$ )
- ◆ Do mirrors suffer from chromatic aberration?

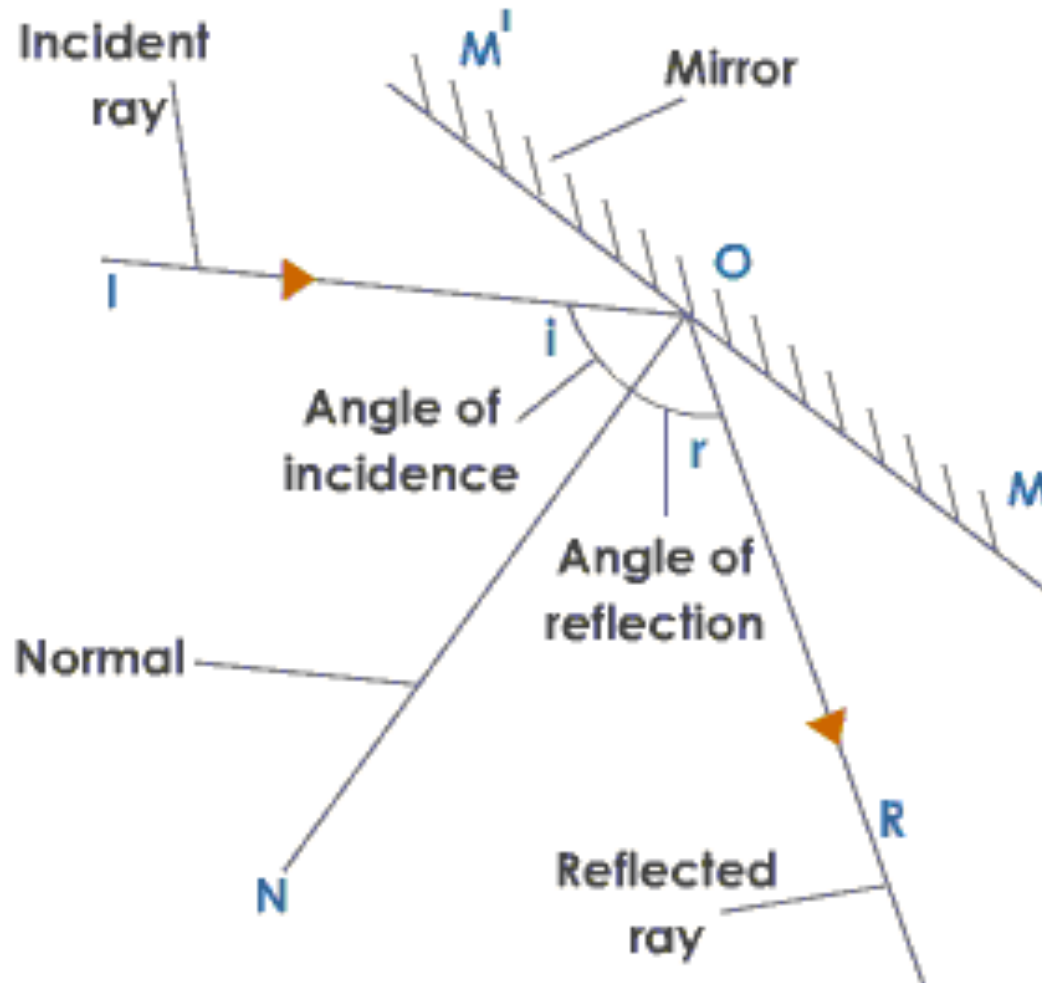

# Chromatic Aberration

---

- ◆ Law of reflection: angle of reflection ( $r$ ) = angle of incidence ( $i$ )
- ◆ Do mirrors suffer from chromatic aberration? No, angle of reflection has no dependence on wavelength.
- ◆ Isaac Newton built the first reflecting telescope motivated by the desire to overcome chromatic aberration. At the time, there were various hypotheses for what caused chromatic aberration in a refracting telescope. Newton hypothesized that the reason is the same as why white light separated into colors when passed through a prism.

# Learning Objectives

---

- ◆ Optical Aberrations:
  - field curvature
  - spherical aberration
  - coma
  - astigmatism
  - distortion
  - chromatic aberration
- ◆ Telescope Configurations:
  - refractors
  - reflectors (Prime, Newtonian, Cassegrain, Coudé or Nasmyth, Schmidt, Schmidt-Cassegrain, Maksutov-Cassegrain)
- ◆ Telescope Mounts:
  - equatorial
  - altazimuth
- ◆ Telescope Dome and Observatory Site



# Refractors

---

- ◆ Aberration reduced or eliminated (beyond notice) using aspherical, achromatic, multiple lenses at objective and eyepiece.
- ◆ Largest refractor ever built and used for astronomy is the 1.02-m (40-inch) diameter Yerkes Observatory telescope established by the University of Chicago in 1897.



# Refractors

---

- ◆ Why have larger refracting telescopes not been built for astronomy since?



# Refractors

---

- ◆ Why have larger refracting telescopes not been built for astronomy since?
  - large lenses are heavy and sag (deform) under their own weight
  - chromatic aberration cannot be eliminated
  - light absorbed by lens
  - to achieve large  $f/\#$  numbers, telescope is long and so requires massive supports and large domes



# Reflectors

---

- ◆ The largest optical telescope so-far built for astronomy is the 10.4-m diameter Gran Telescopio Canarias.
- ◆ Astronomers are currently planning and designing a 30-m aperture telescope (TMT) to be located on Mauna Kea, Hawaii. China is among the consortium members.



10.4-m Gran Telescopio Canarias



Artist's conception of the TMT

# Reflectors

---

- ◆ ... And ESO is building the ESO ELT (extremely large telescope)

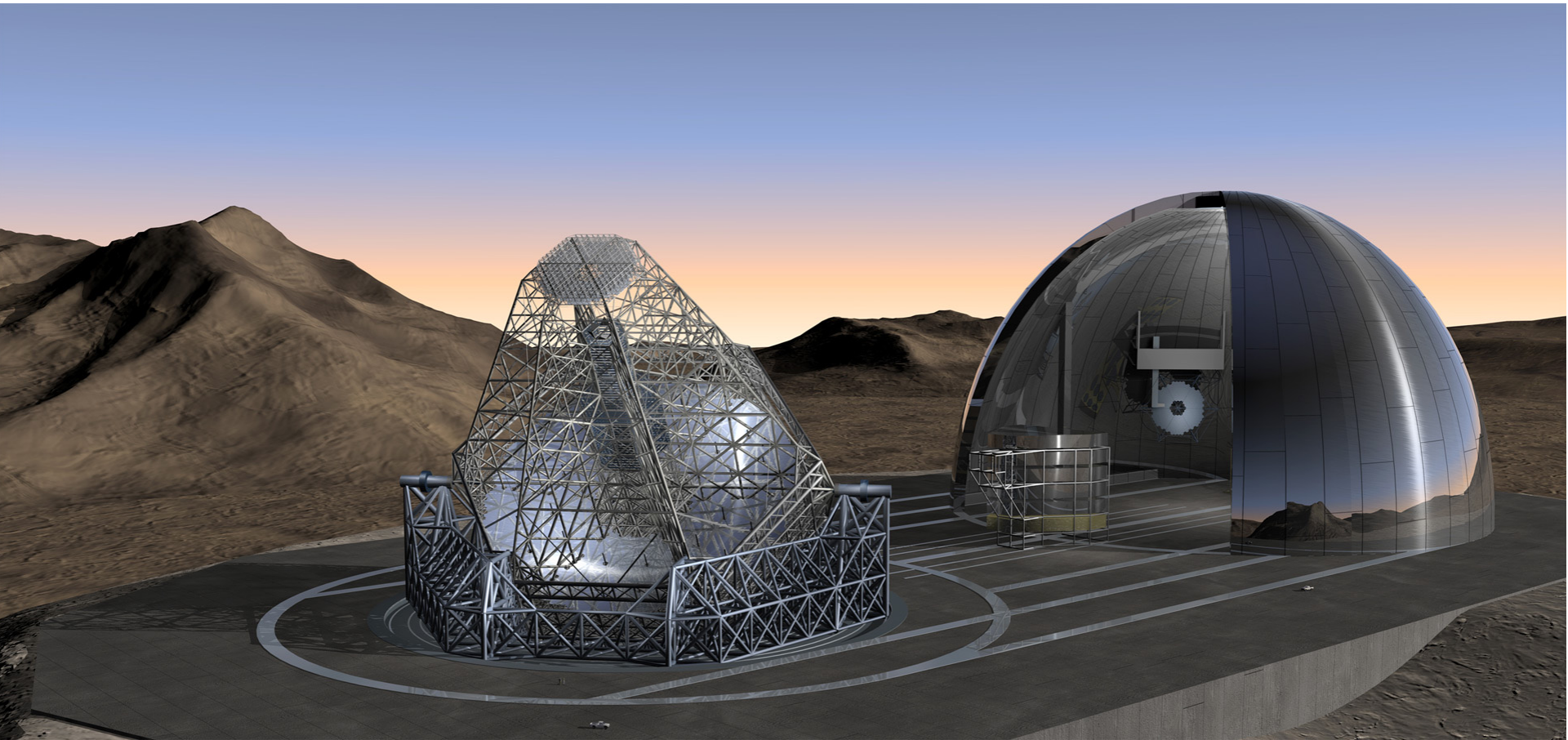

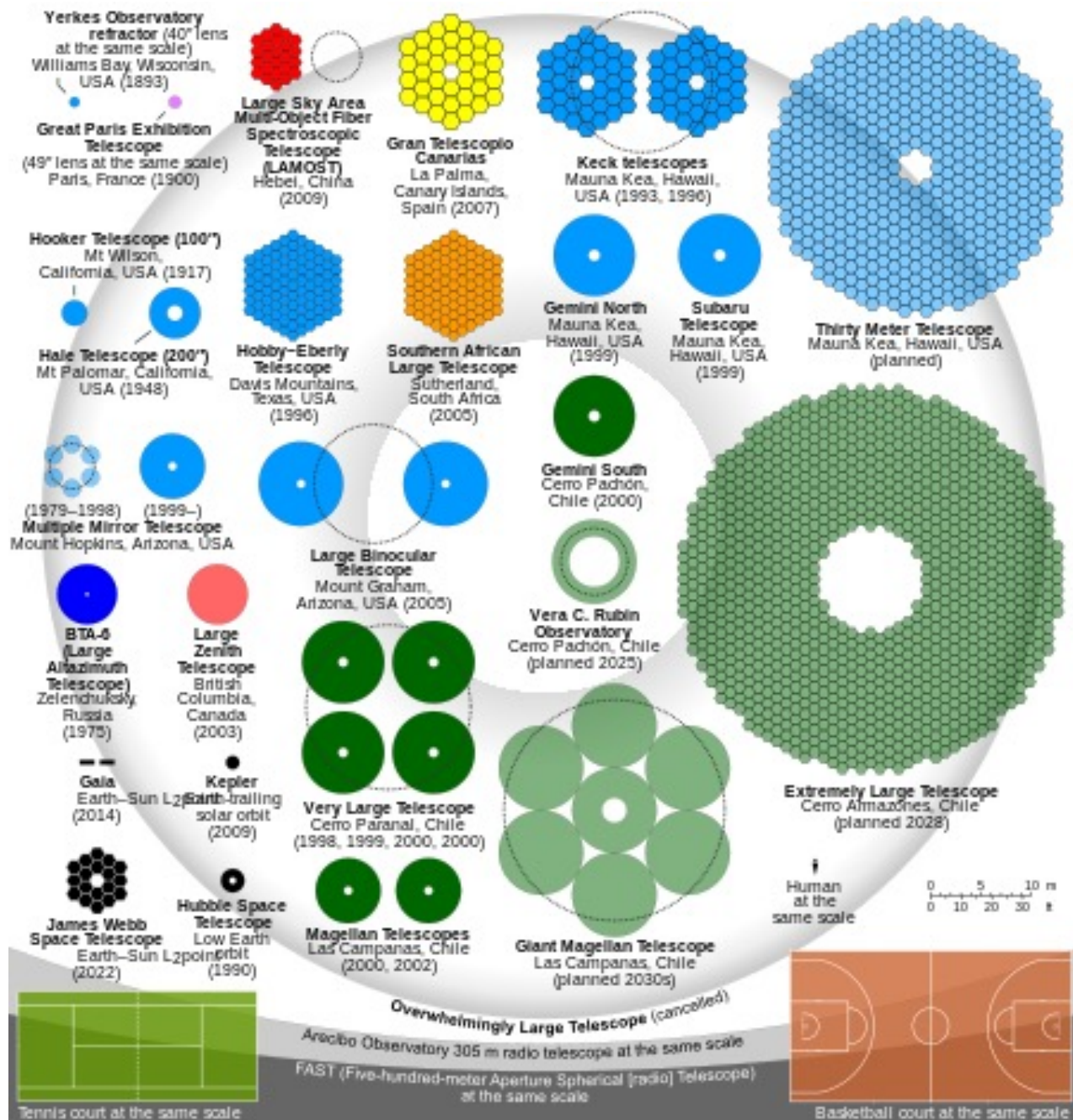

# Reflectors

---

- ◆ What are the advantages of reflectors over refractors?



10.4-m Gran Telescopio Canarias



Artist's conception of the TMT

# Reflectors

---

## ◆ What are the advantages of reflectors over refractors?

- mirror can be supported from the back and gravitational deformations corrected using active optics
- no chromatic aberration
- mirrors can have higher reflectivity than lenses have transparency
- by having multiple reflections inside telescope tube, telescope can be shorter to achieve same  $f/$  number and so requires less massive supports and domes

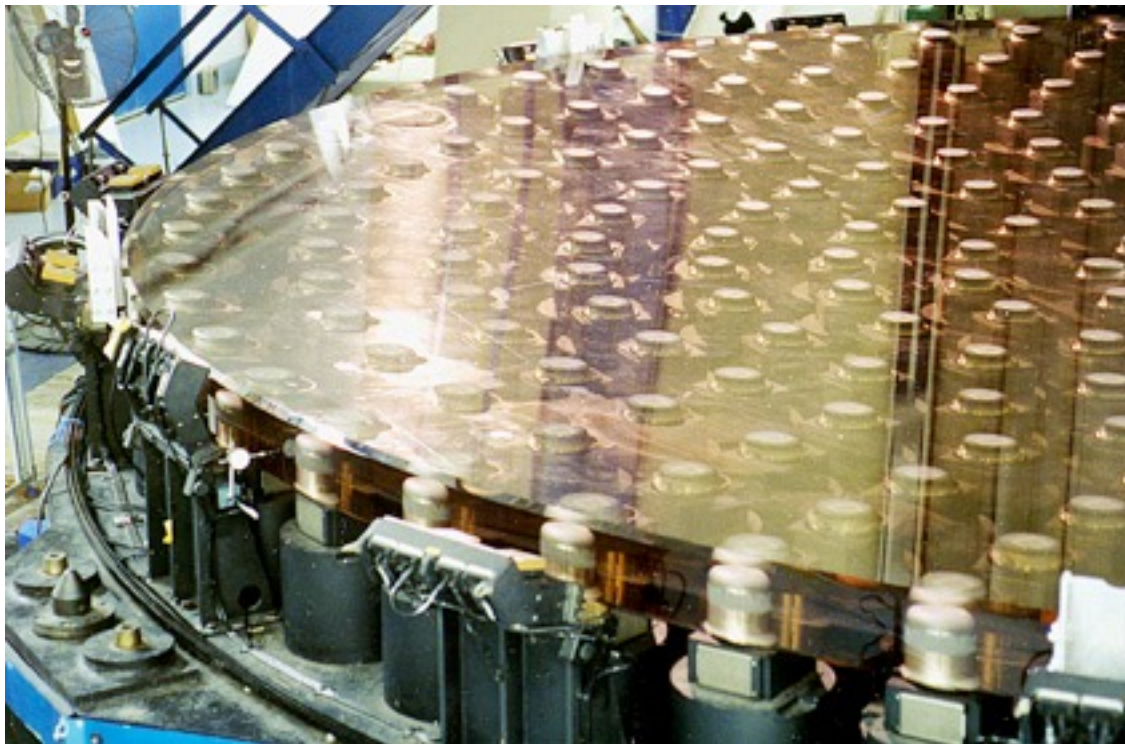

mirror before  
aluminizing

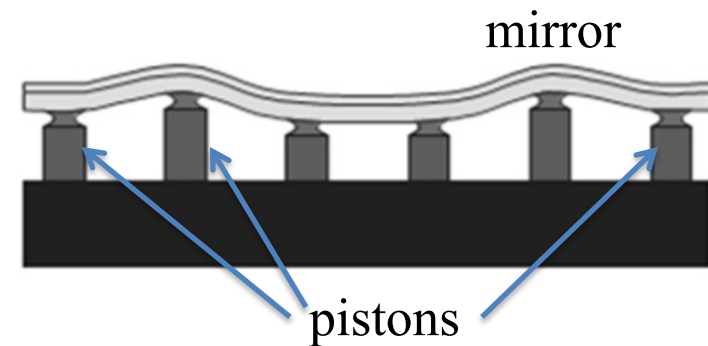



# Reflectors

---

## ◆ What are the advantages of reflectors over refractors?

- mirror can be supported from the back and gravitational deformations corrected using active optics
- no chromatic aberration
- mirrors can have higher reflectivity than lenses have transparency
- by having multiple reflections inside telescope tube, telescope can be shorter to achieve same  $f/$  number and so requires less massive supports and domes

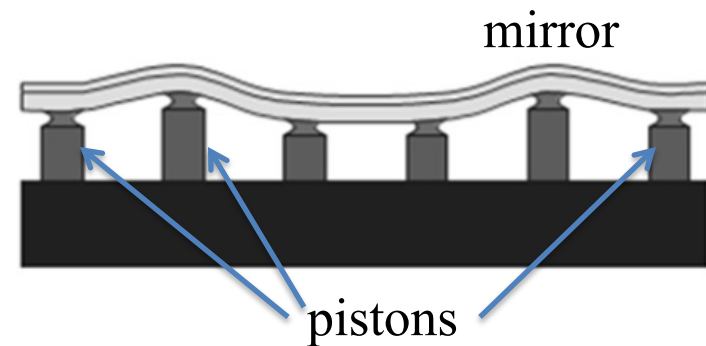
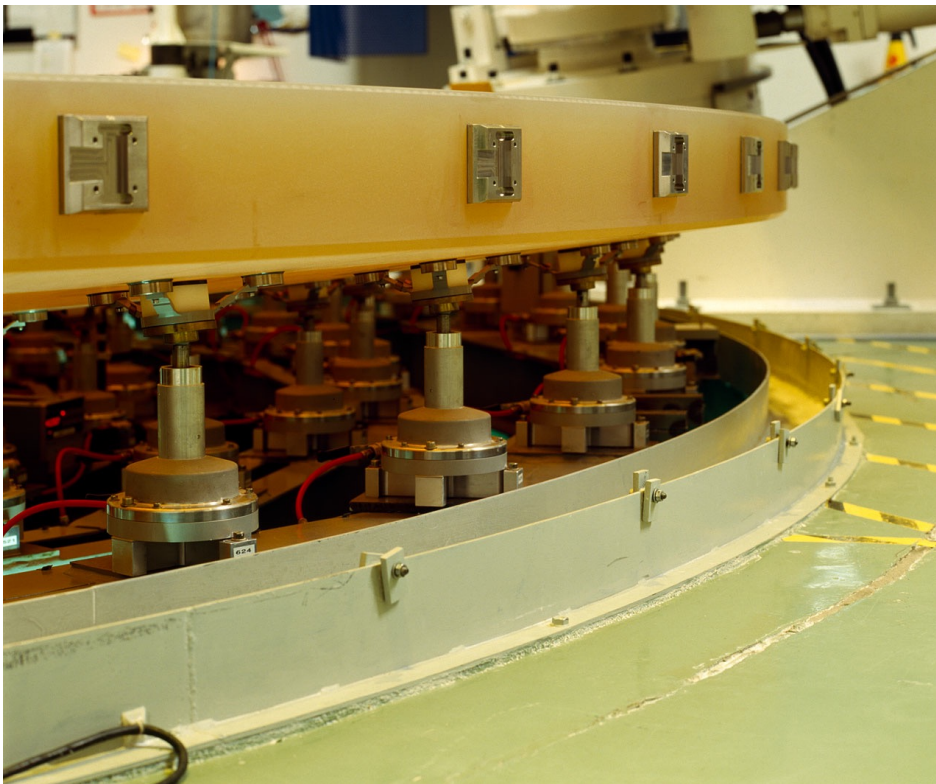

# Reflectors

---

◆ Different focal configurations for a reflecting telescope:

- Prime
- Newtonian
- Cassegrain
- Coudé or Nasmyth

If the secondary mirror is curved rather than flat, the focal length of the telescope can be changed (lengthened).

<http://www.telescope-optics.net/two-mirror.htm>

Prime Focus

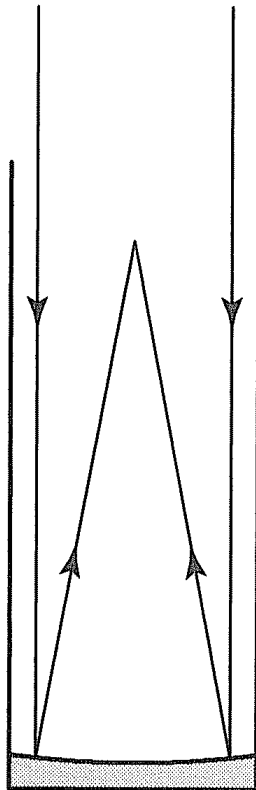

Newtonian

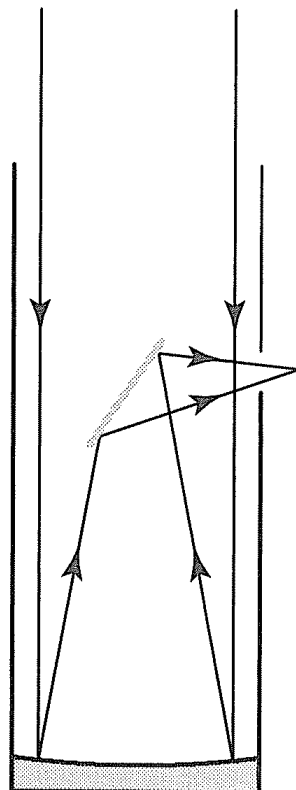

Cassegrain

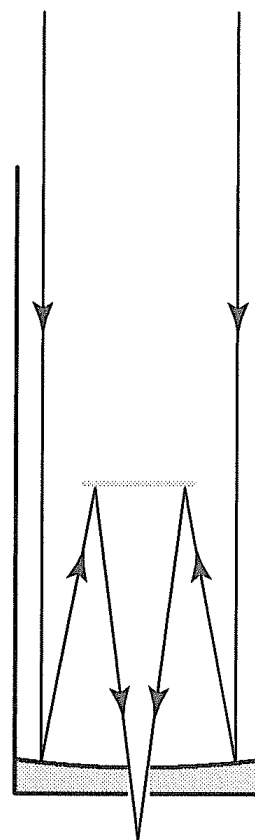

Coudé

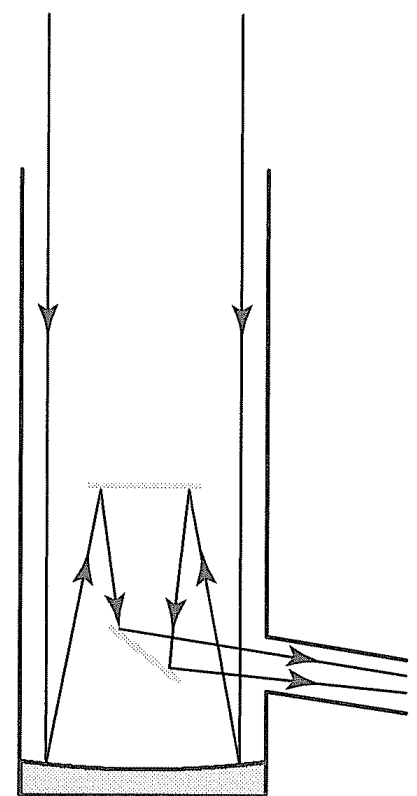

# Reflectors

---

- ◆ Prime focus employs detector at focus directly above objective mirror.

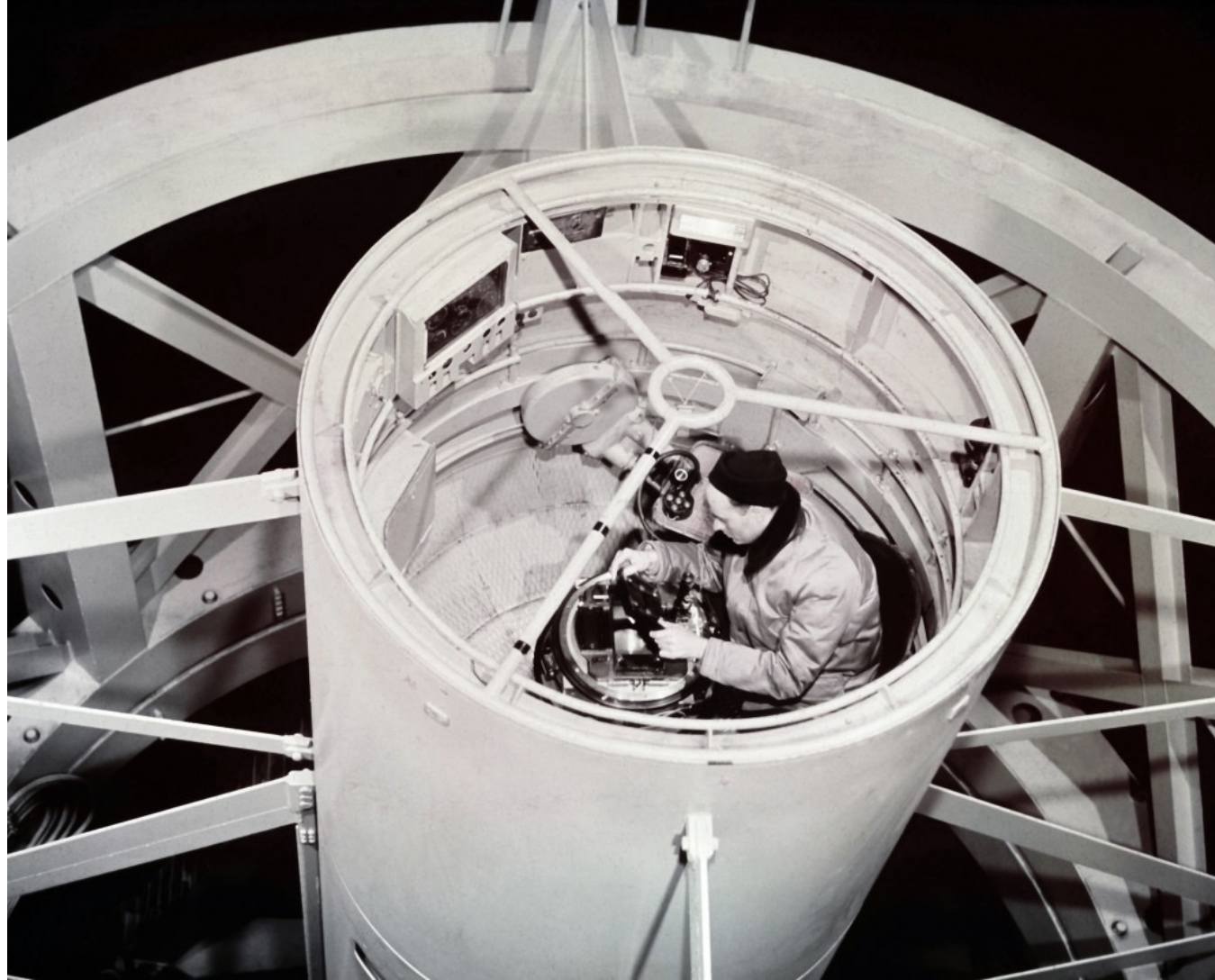
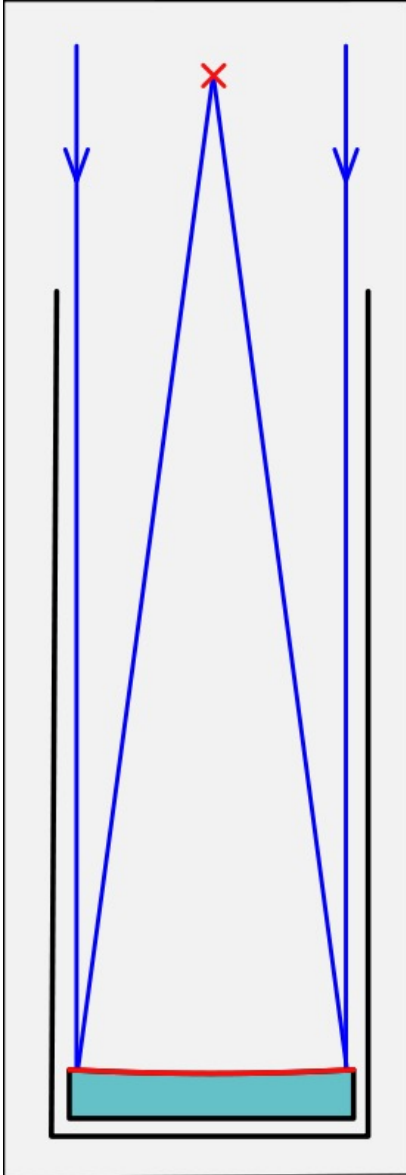

5-m Hale Telescope

# Reflectors

- ◆ Prime focus employs detector at focus directly above objective mirror.

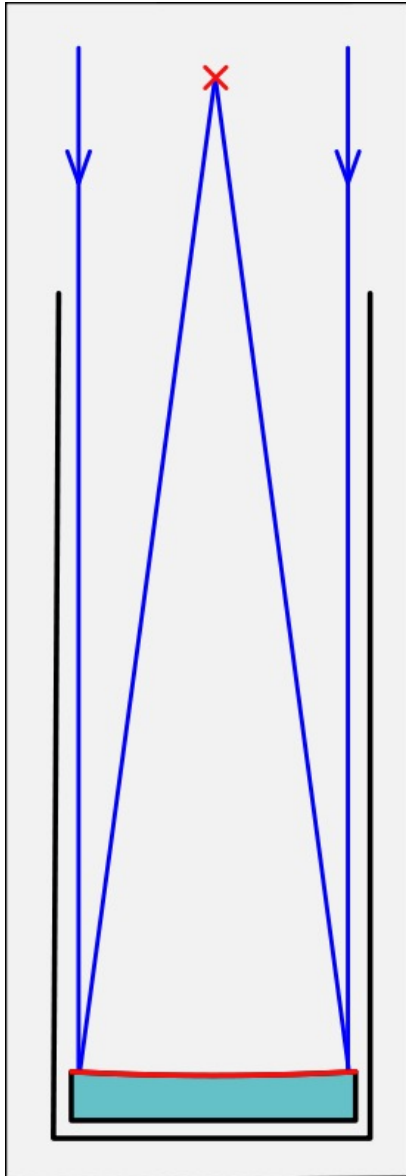

3.6-m Canadian-France-Hawaii Telescope

# Reflectors

- ◆ Why are wide-field cameras deployed at the prime focus?

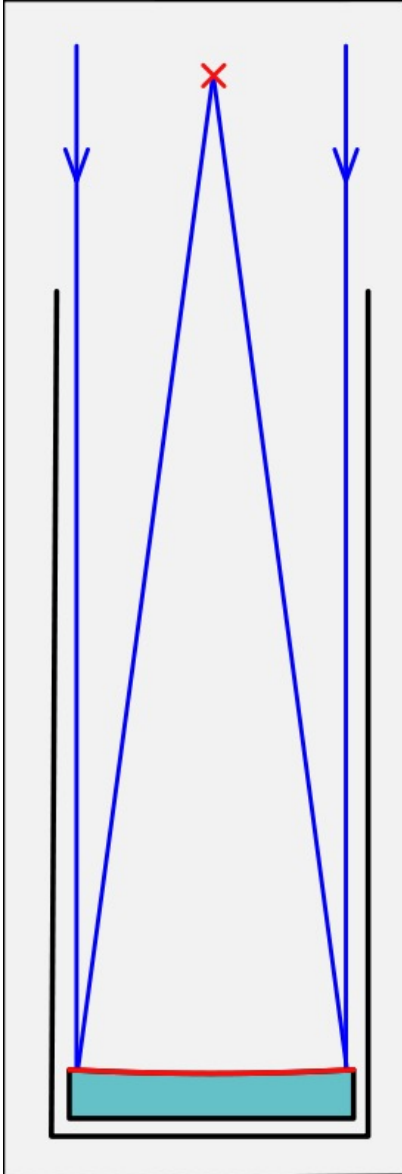

8.2-m Subaru Telescope

# Reflectors

- ◆ Why are wide-field cameras deployed at the prime focus? **Shortest focal length.**

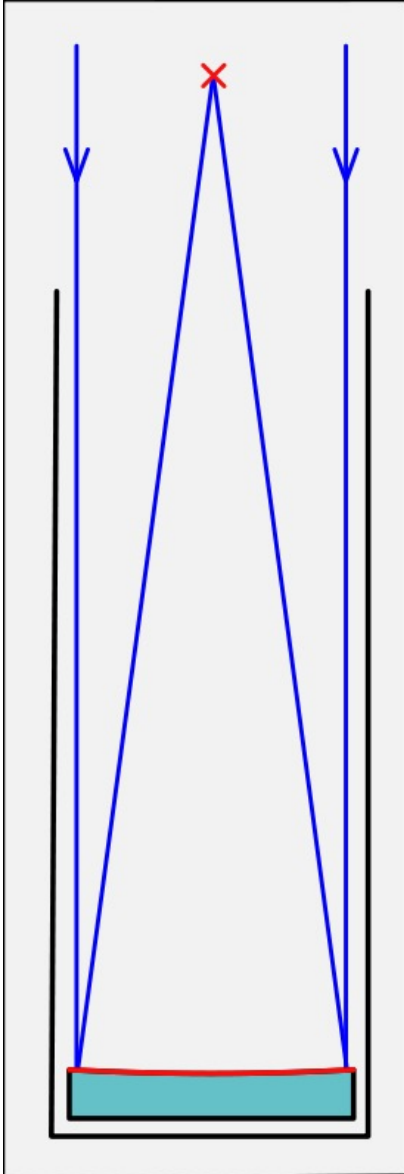

8.2-m Subaru Telescope

# Reflectors

---

- ◆ Newtonian uses a secondary mirror to reflect light through the side of a telescope.
- ◆ The first reflecting telescope, invented and built by Isaac Newton in 1668. Newton hypothesized that chromatic aberration was caused by lenses splitting white light into its spectrum of colors, and that this problem could be avoided using mirrors.

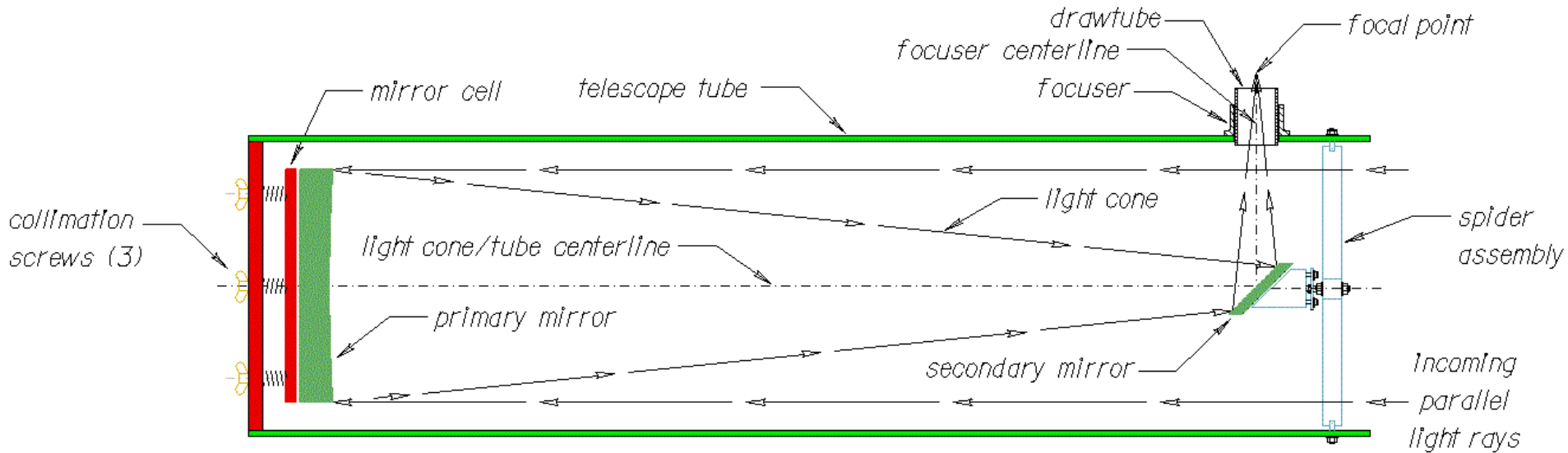

# Reflectors

---

- ◆ Newtonian uses a secondary mirror to reflect light through the side of a telescope.
- ◆ The first reflecting telescope, invented and built by Isaac Newton in 1668. Newton hypothesized that chromatic aberration was caused by lenses splitting white light into its spectrum of colors, and that this problem could be avoided using mirrors.



Replica of Newton's second telescope





# Reflectors

---

- ◆ Cassegrain uses a secondary mirror to reflect light back through a hole in the objective mirror, attributed to Laurent Cassegrain in 1672.

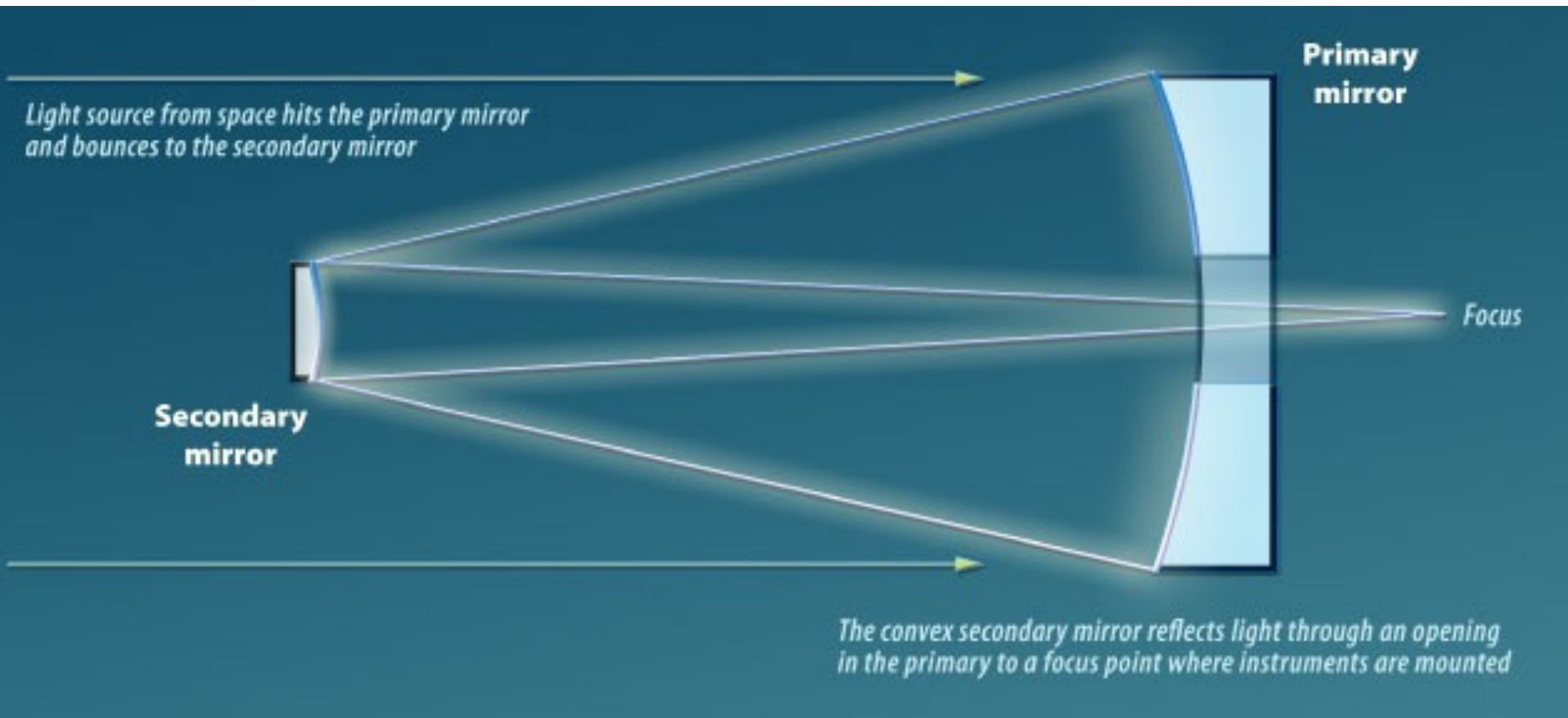

# Reflectors

---

- ◆ Cassegrain uses a secondary mirror to reflect light back through a hole in the objective mirror, attributed to Laurent Cassegrain in 1672.
- ◆ A compact and balanced design popular in amateur telescopes, and basic configuration of most research telescopes.

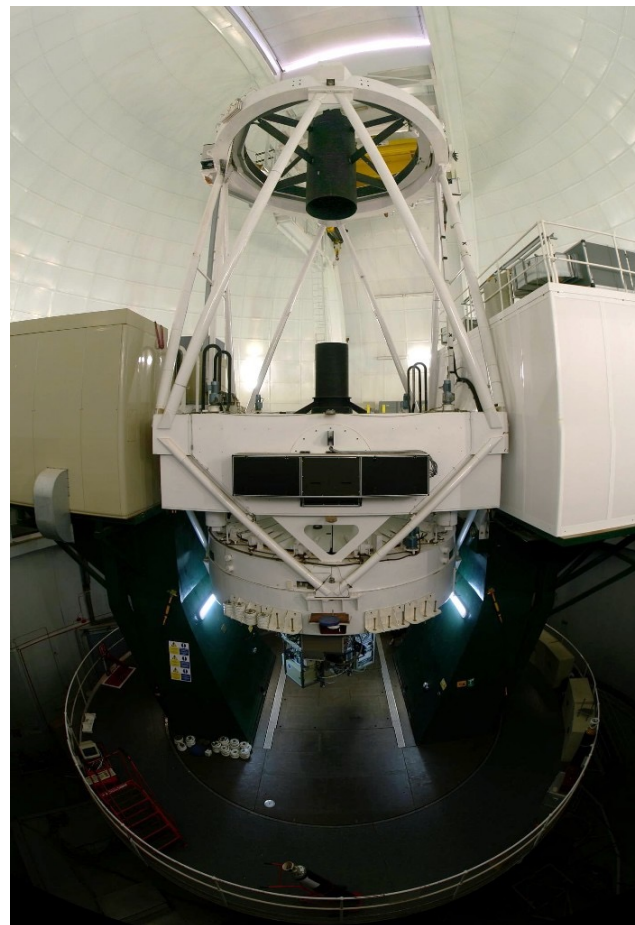

4.2-m William Herschel Telescope

# Reflectors

---

- ◆ Coudé or Nasmyth focus, invented by James Nasmyth in the 19<sup>th</sup> century. This configuration uses a tertiary mirror to divert light from the secondary mirror through the side of the telescope before again reaching the objective mirror.

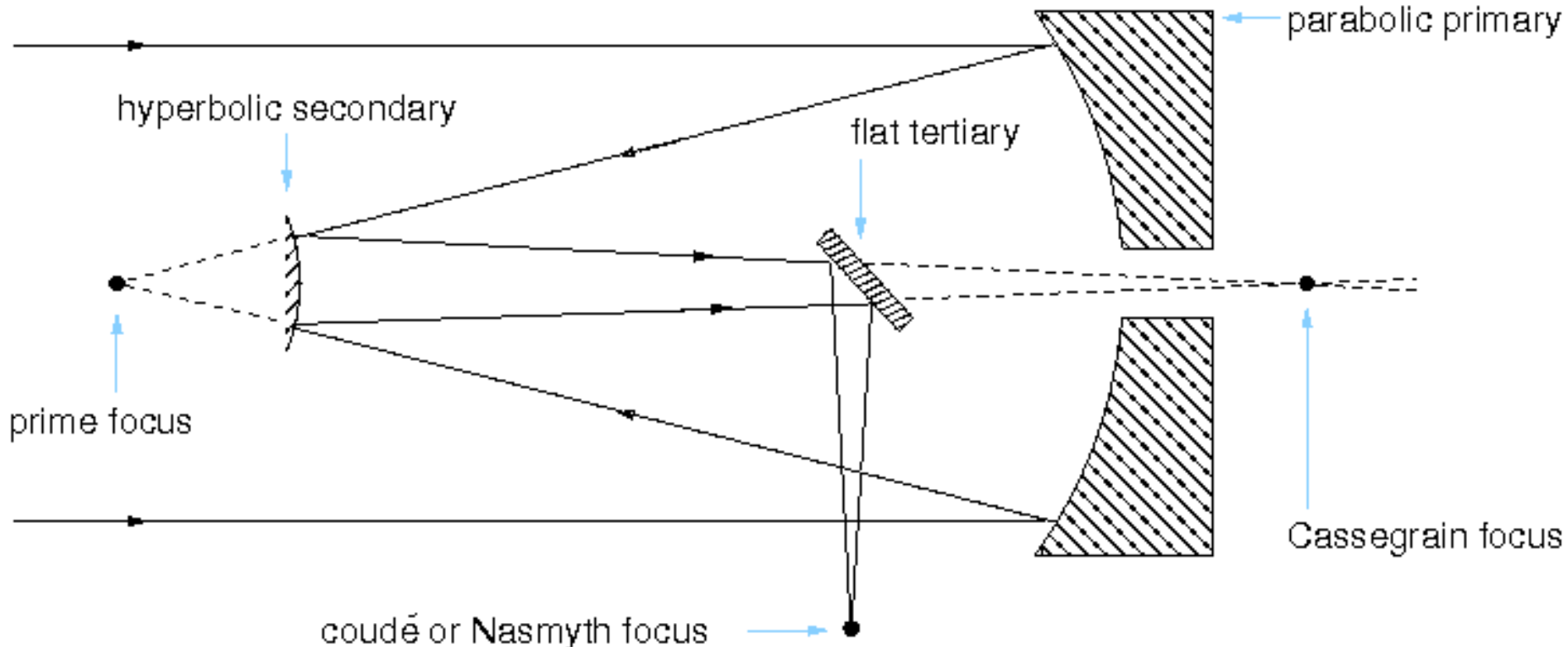

# Reflectors

- ◆ Coudé or Nasmyth focus, invented by James Nasmyth in the 19<sup>th</sup> century. This configuration uses a tertiary mirror to divert light from the secondary mirror through the side of the telescope before again reaching the objective mirror.
- ◆ Common configuration of research telescopes, permitting heavy instruments to be mounted on optical benches rather than attached to the telescope.

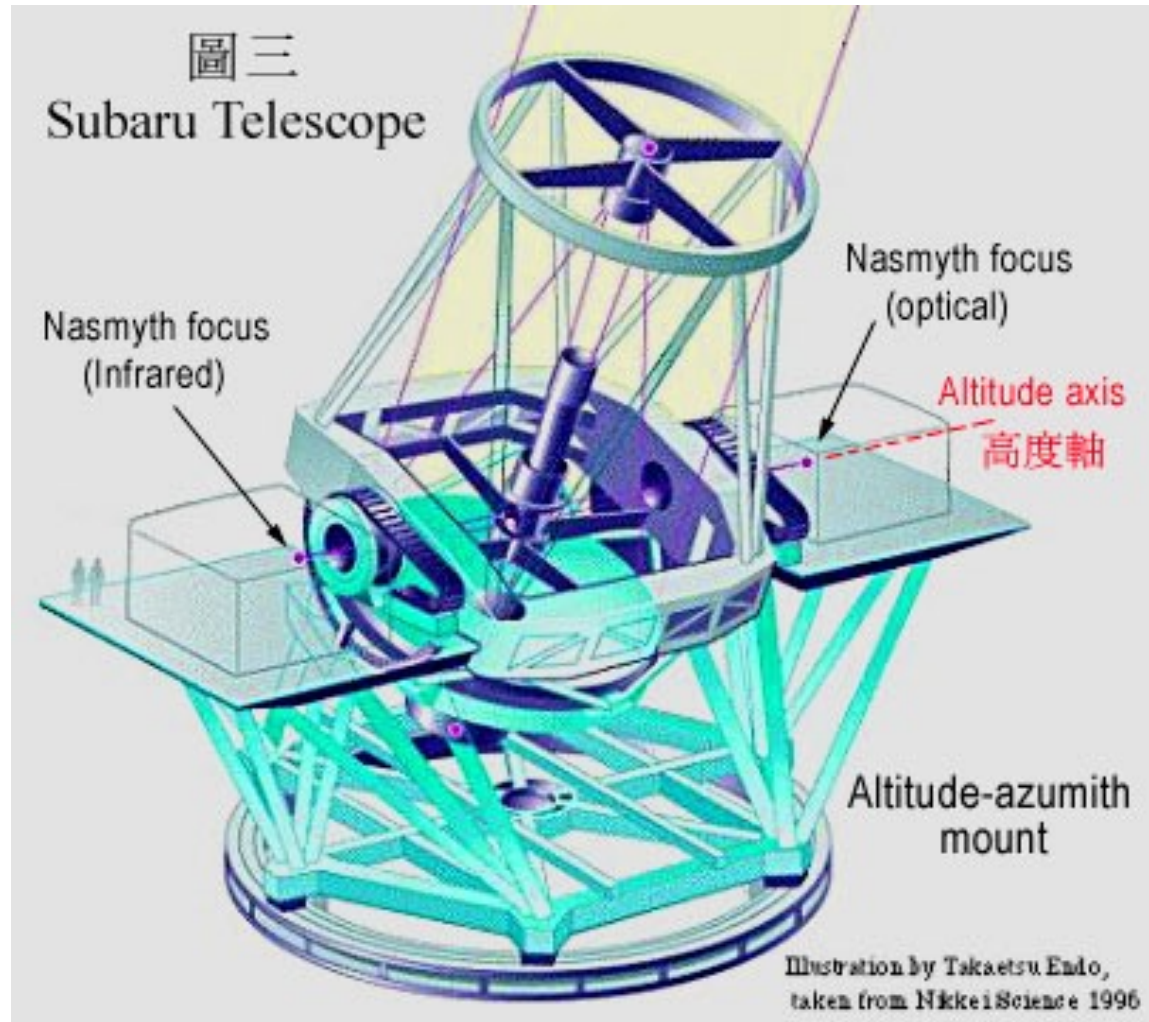

# Reflectors

---

- ◆ Schmidt telescopes employ a (easy-to-make) spherical mirror and an aspherical correcting lens to correct for spherical aberration (invented by German optician Bernhard Schmidt in 1930).

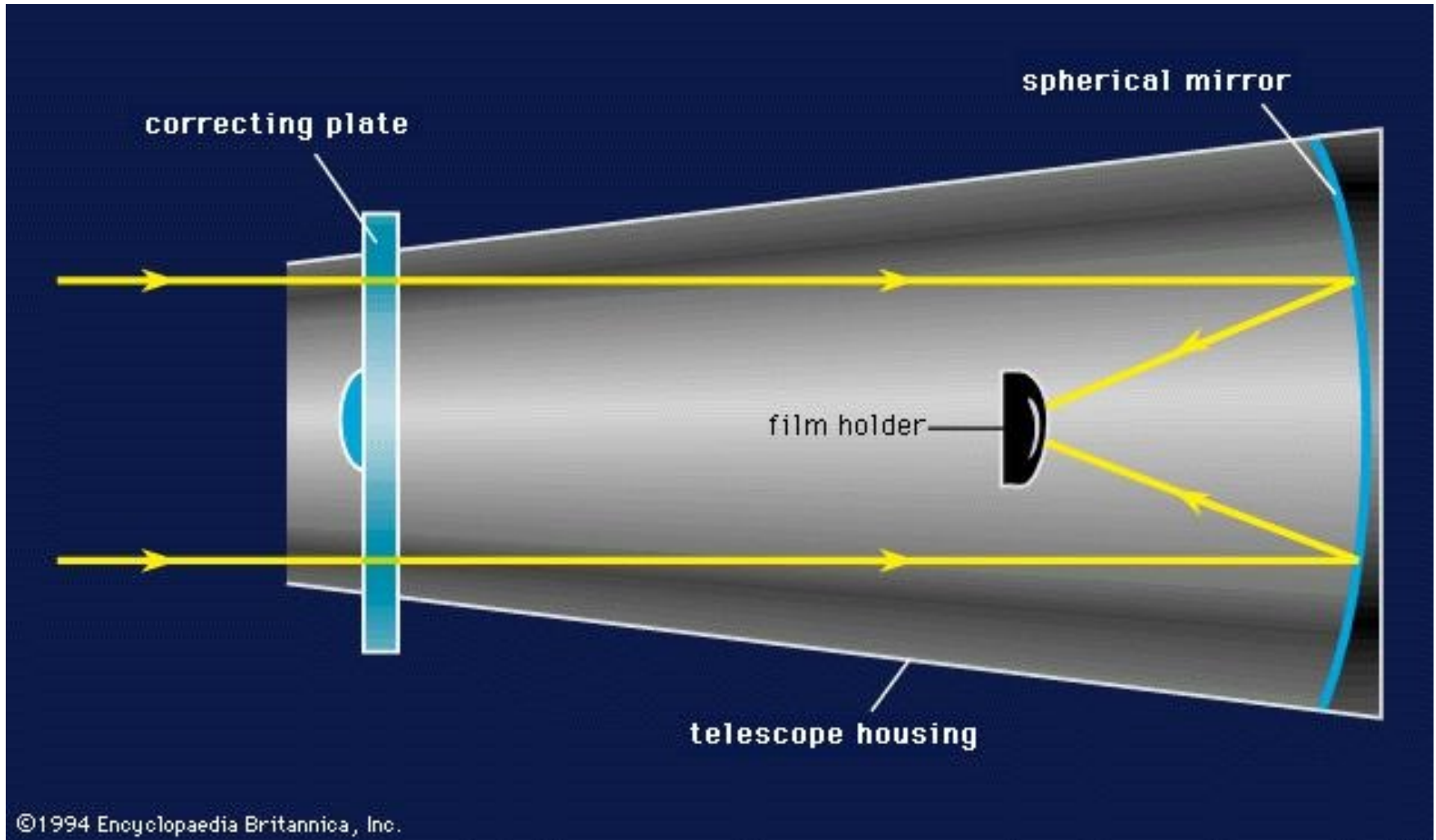

# Reflectors

---

- ◆ Schmidt telescopes employ a (easy-to-make) spherical mirror and an aspherical correcting lens to correct for spherical aberration (invented by German optician Bernhard Schmidt in 1930).
- ◆ Schmidt-Cassegrain telescopes employ, in addition, a secondary mirror to reflect light back through the objective mirror.

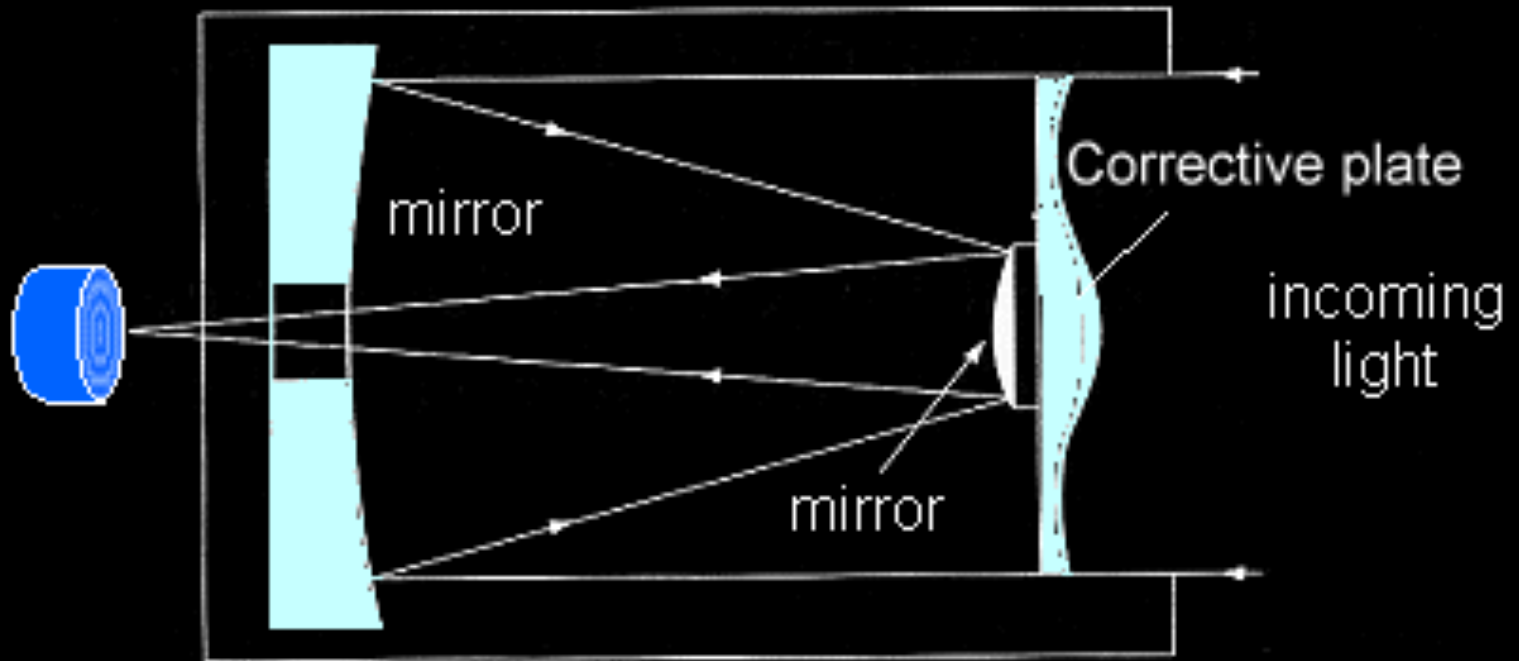

# Reflectors

---

- ◆ Maksutov-Cassegrain employs a spherical mirror and a spherical correcting lens (concave meniscus), with the secondary mirror formed by aluminizing a spot inside of the lens (patented in 1941 by Russian optician Dmitri Dmitrievich Maksutov).

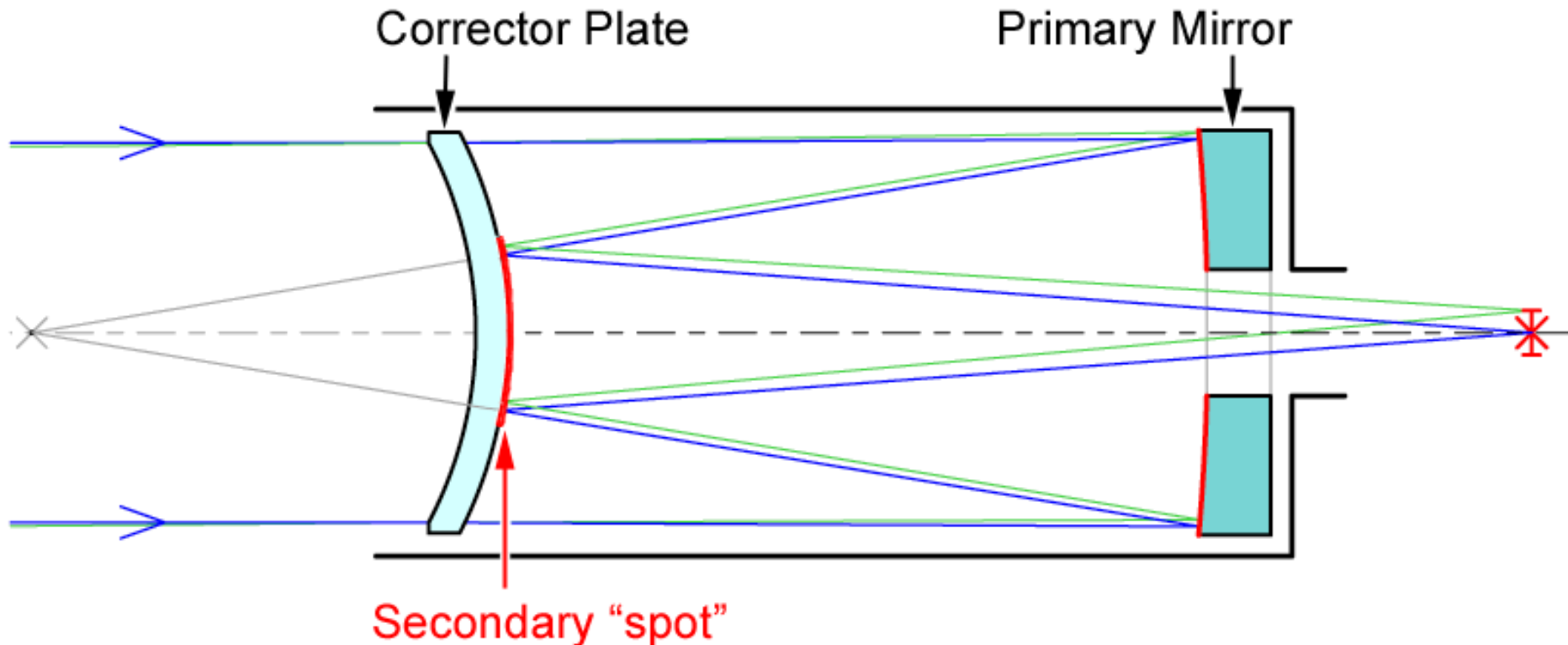

# Reflectors

---

- ◆ Schmidt-Cassegrain telescopes were used by astronomers to study large swaths of the sky or to make sky surveys.
- ◆ One of the most famous sky surveys was the Palomar Observatory Sky Survey that began in 1949 and was completed in 1958. The Survey utilized a 1.2-m Schmidt telescope, recording images on 3.7x3.7-inch glass photographic plates covering  $6.5^\circ \times 6.5^\circ$  each. The Survey was made in a red-sensitive and blue-sensitive plate, is complete to a declination of  $-30^\circ$  at plate centers, and utilized a total of 936 plate pairs.

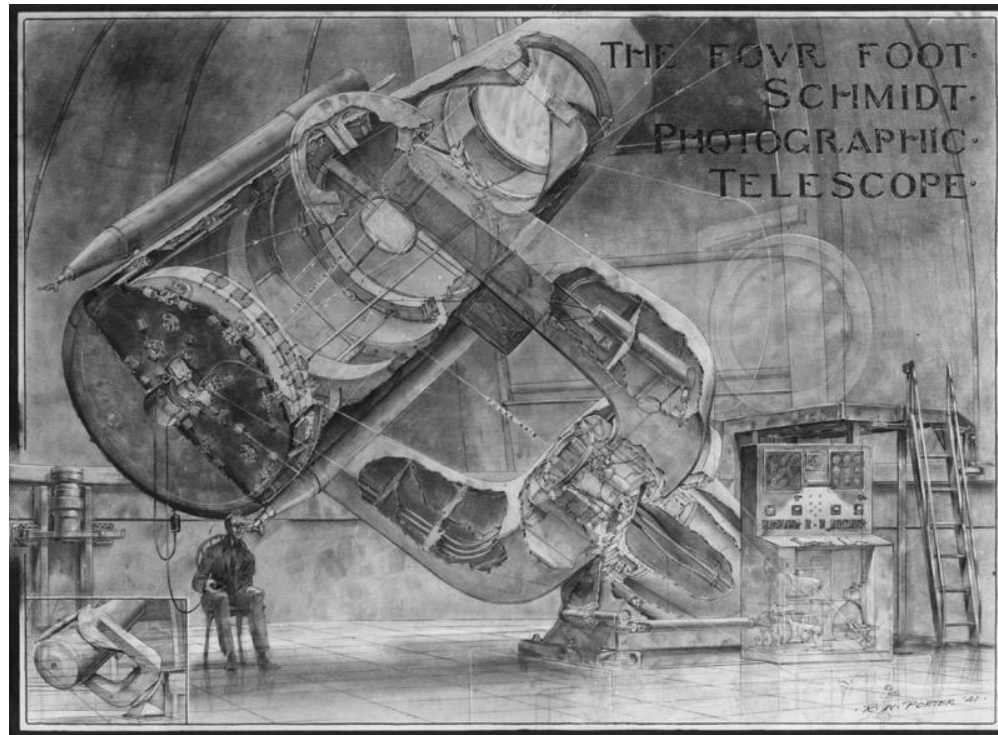



# Reflectors

---

- ◆ Modern wide-field telescopes such as the 2.5-m Sloan Digital Sky Survey (SDSS) – field of view of  $2^\circ.5 \times 2^\circ.5$  – telescopes use a Cassegrain-type configuration along with two correcting lenses.

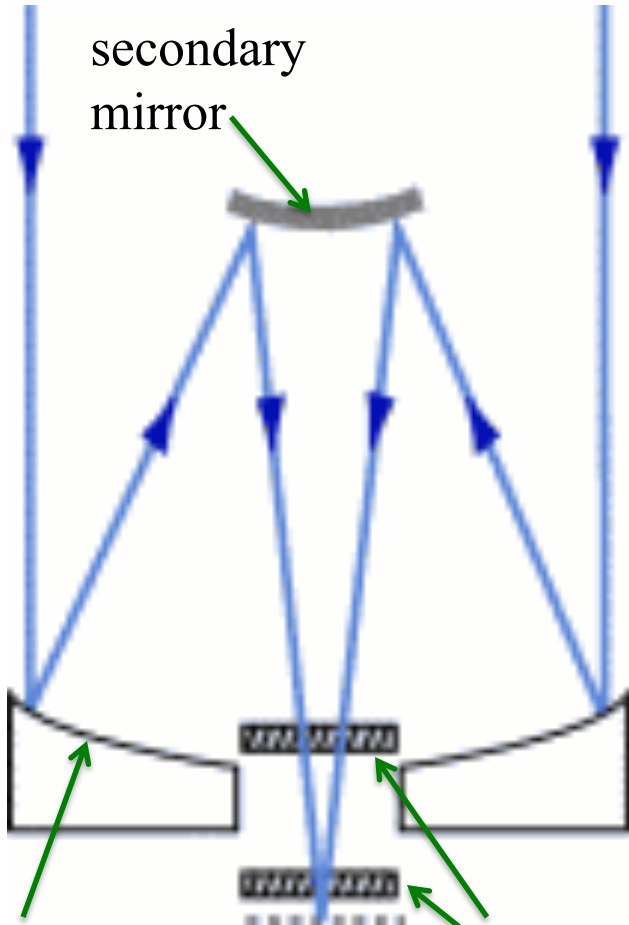

objective mirror  
(Ritchey-Chrétien)

correcting lenses  
(reduce astigmatism)

# Reflectors

---

- ◆ Modern large optical telescopes often use segmented mirrors, which are easier to manufacture than a single large mirror.

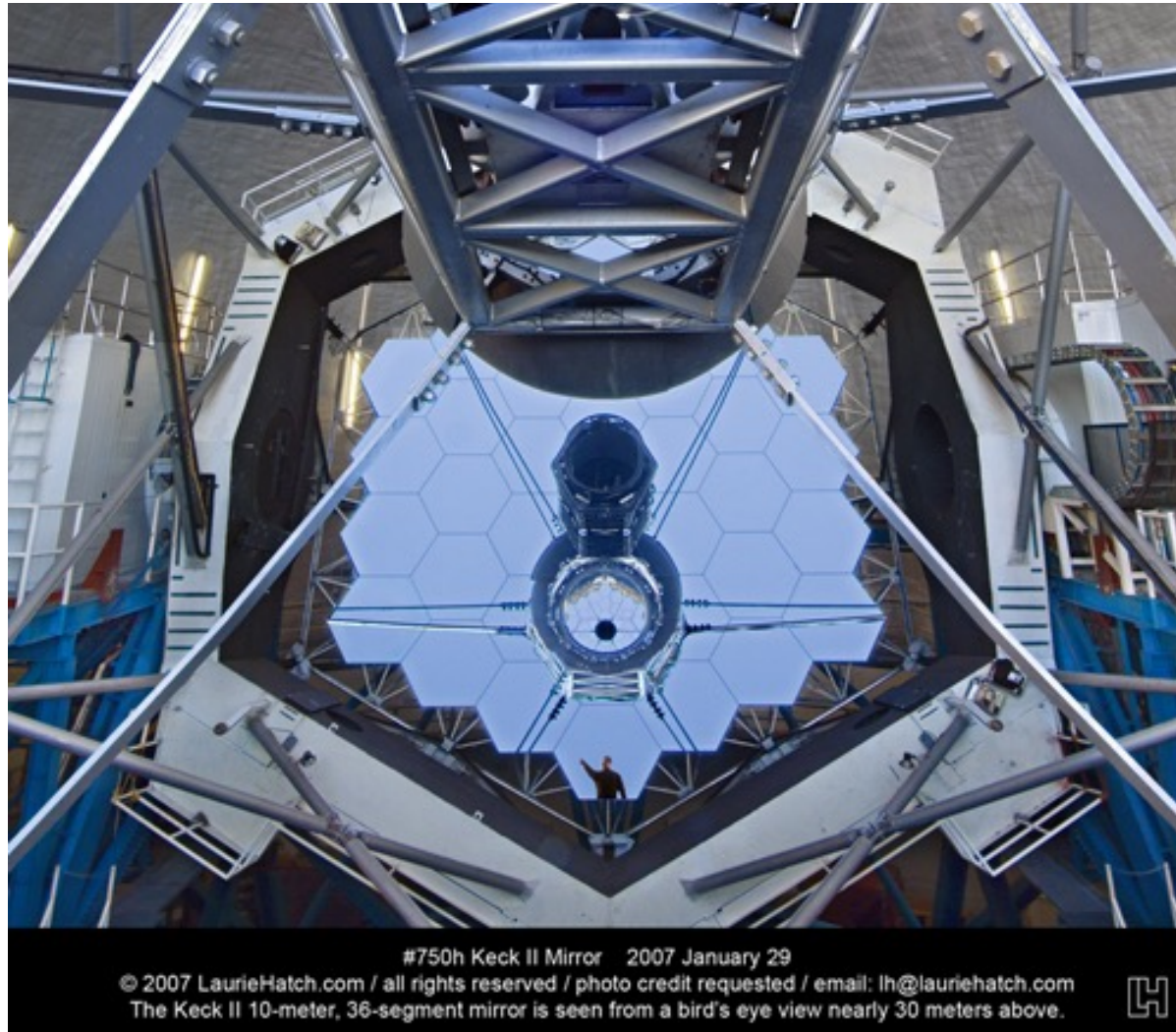

10-m Keck Telescope

# Reflectors

---

- ◆ New and, sometimes, revolutionary designs are under constant exploration.
- ◆ An example is the 6-m Large Zenith Telescope, where the objective mirror comprises liquid mercury! Cost: <US\$1M

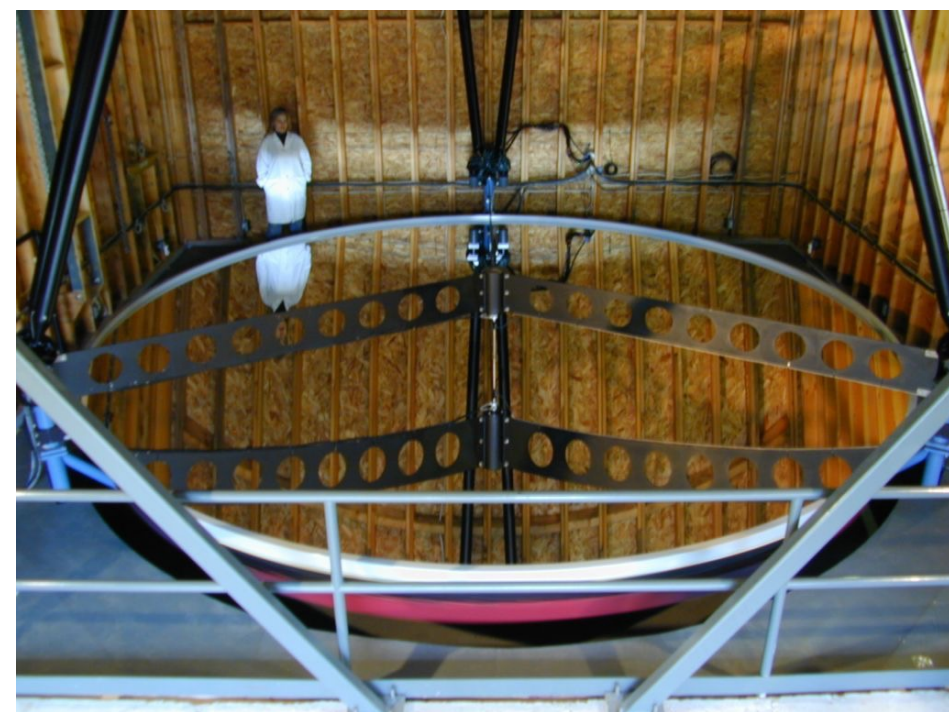

6-m Large Zenith Telescope



Rotate at period of  $\sim 8.5$  seconds to get a thin ( $\sim 2$  mm) layer of Mercury

# Reflectors

---

- ◆ Example of pictures from the Large Zenith Telescope.

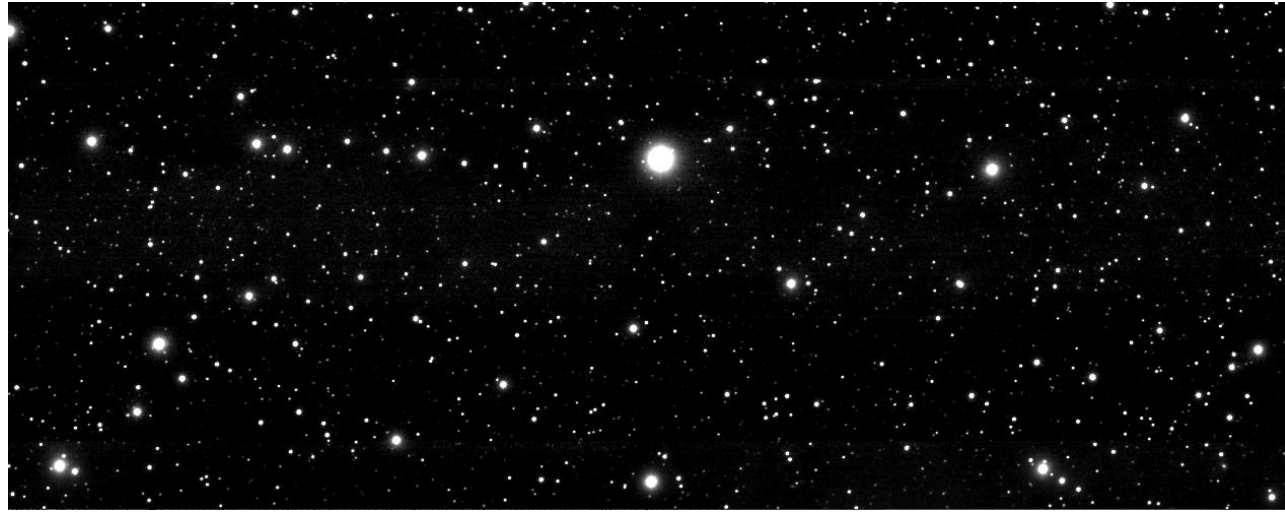

# Learning Objectives

---

- ◆ Optical Aberrations:
  - field curvature
  - spherical aberration
  - coma
  - astigmatism
  - distortion
  - chromatic aberration
- ◆ Telescope Configurations:
  - refractors
  - reflectors (Prime, Newtonian, Cassegrain, Coudé or Nasmyth, Schmidt, Schmidt-Cassegrain, Maksutov-Cassegrain)
- ◆ Telescope Mounts:
  - equatorial
  - altazimuth
- ◆ Telescope Dome and Observatory Site

# Telescope Tubes

---

- ◆ What is the purpose of telescope tubes?



Telescope tube



# Telescope Tubes

---

- ◆ What is the purpose of telescope tubes?
  - support the telescope components (amateur telescopes usually use closed designs, research telescopes open designs)



Telescope tube

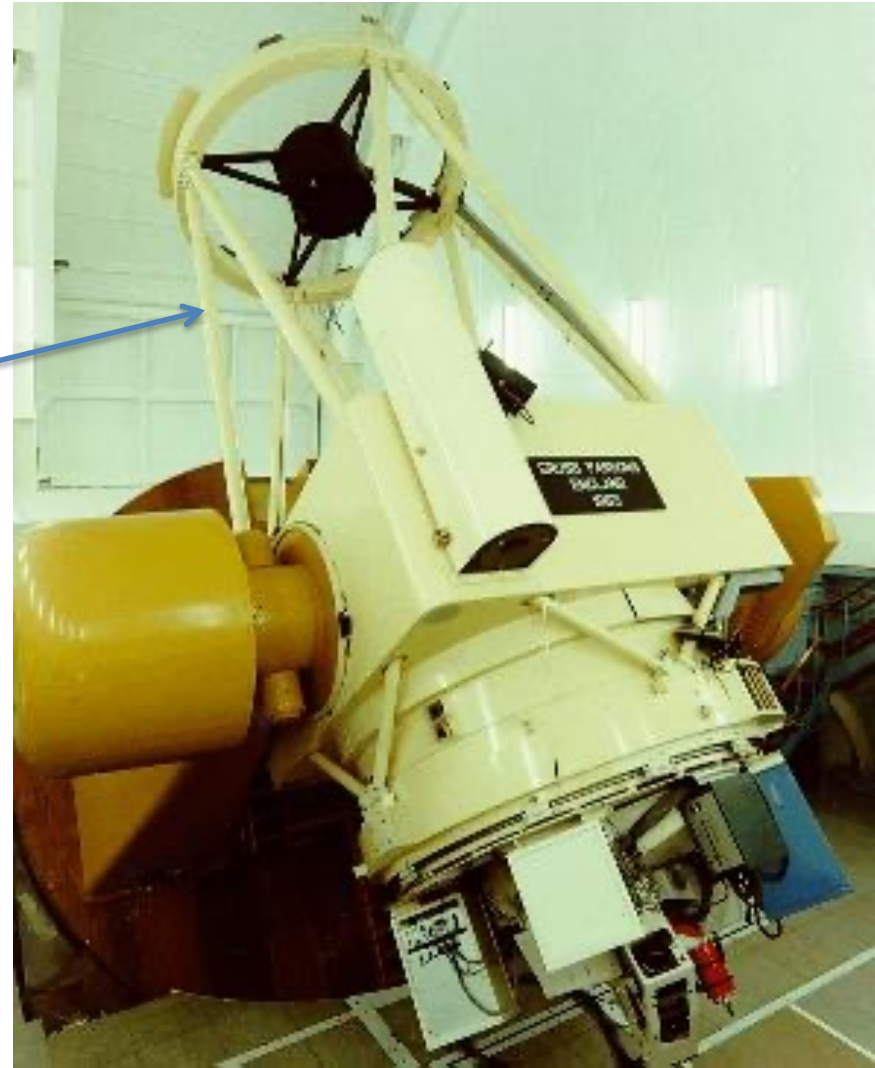

# Telescope Mounts

---

- ◆ What are the purposes of telescope mounts?





# Telescope Mounts

---

- ◆ What are the purposes of telescope mounts?
  - support the telescope tube
  - point the telescope and track an object



# Telescope Mounts

---

- ◆ A stable and rigid mount is important not just in research telescopes but also in amateur telescopes.
- ◆ Two types of mounts: equatorial and altazimuth (altitude-azimuth, or alt-az) mounts.

## Equatorial mount



## Altazimuth mount

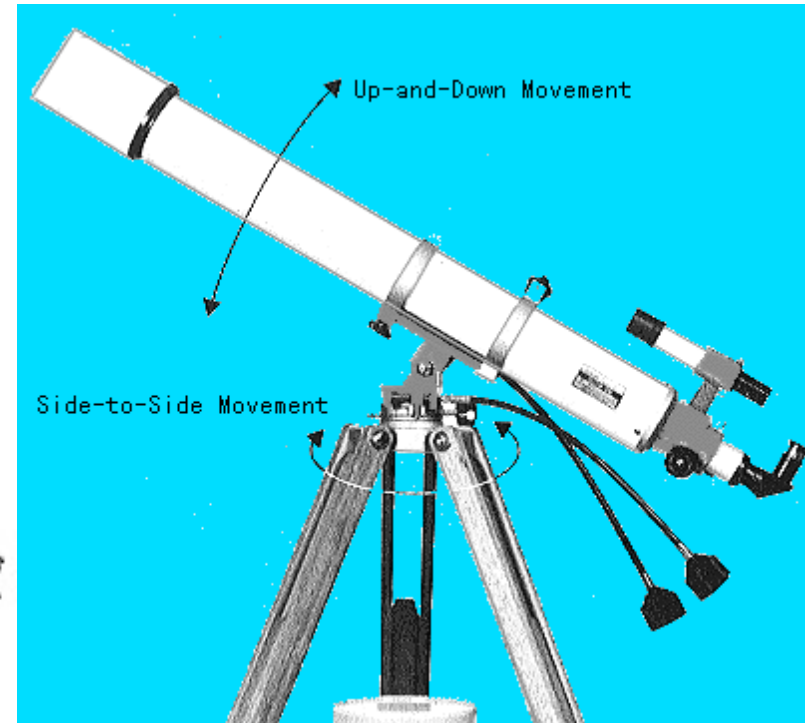

# Telescope Mounts

---

- ◆ A stable and rigid mount is important not just in research telescopes but also in amateur telescopes.
- ◆ Two types of mounts: equatorial and altazimuth (altitude-azimuth, or alt-az) mounts.

## Equatorial mount

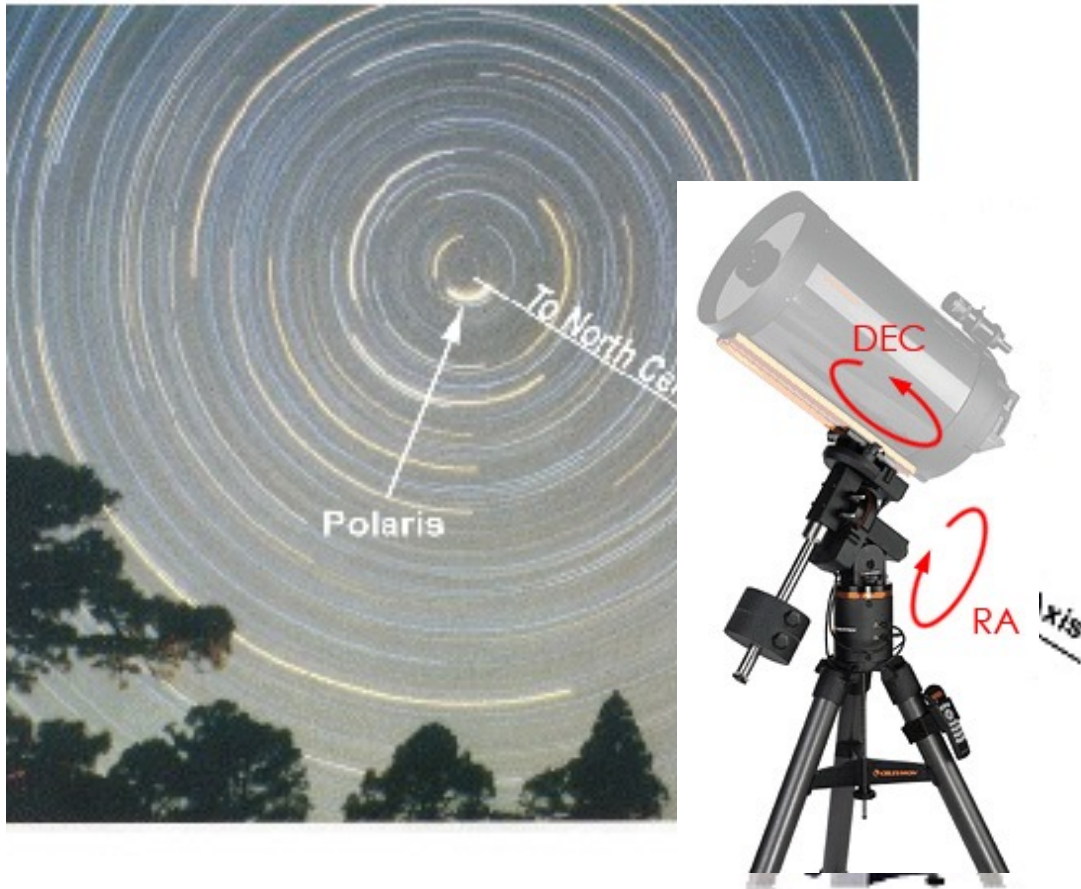

## Altazimuth mount

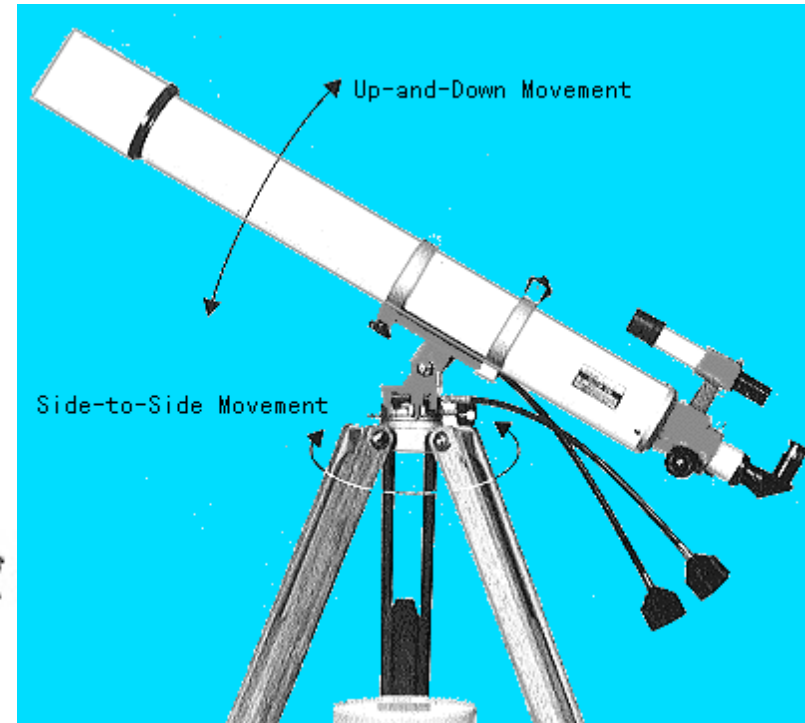

# Telescope Mounts

---

- ◆ As you can see, the difference between an equatorial and an altazimuth mount is that, in an equatorial mount, one axis is directed at the north (or south) celestial pole.

Equatorial fork mount

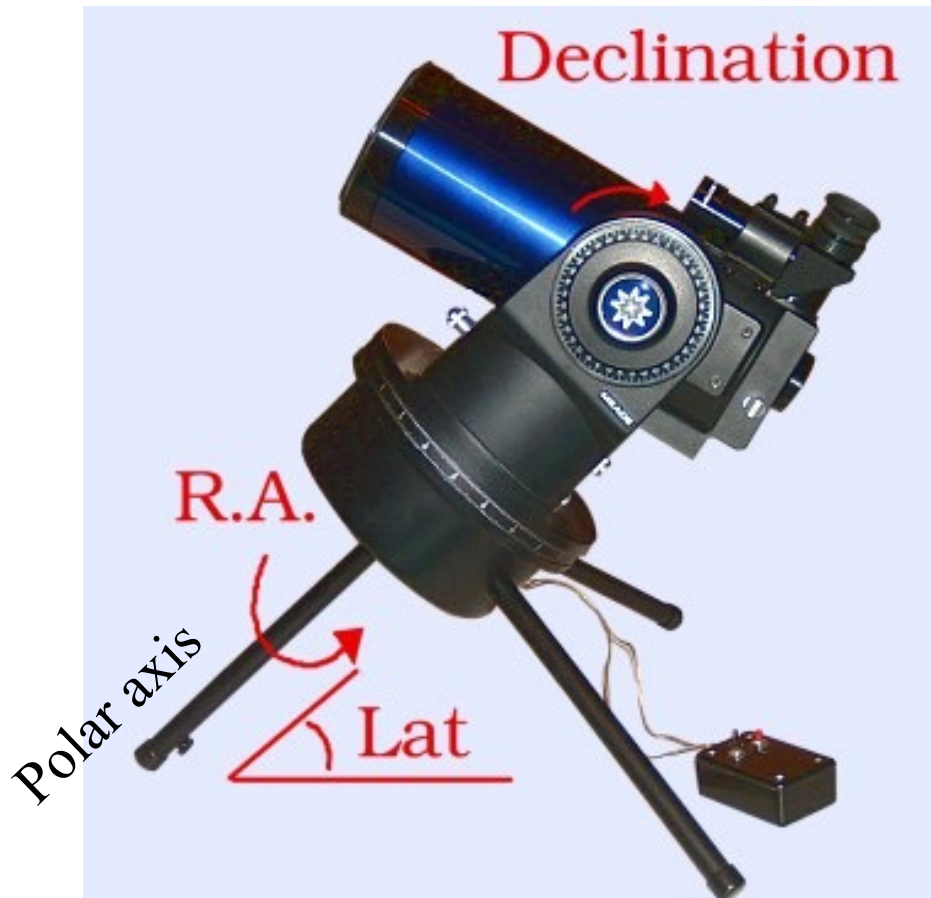

Altazimuth fork mount



# Equatorial Mounts

- ◆ Equatorial mounts have:
  - polar axis parallel to Earth's rotation axis
  - declination axis perpendicular to polar axis

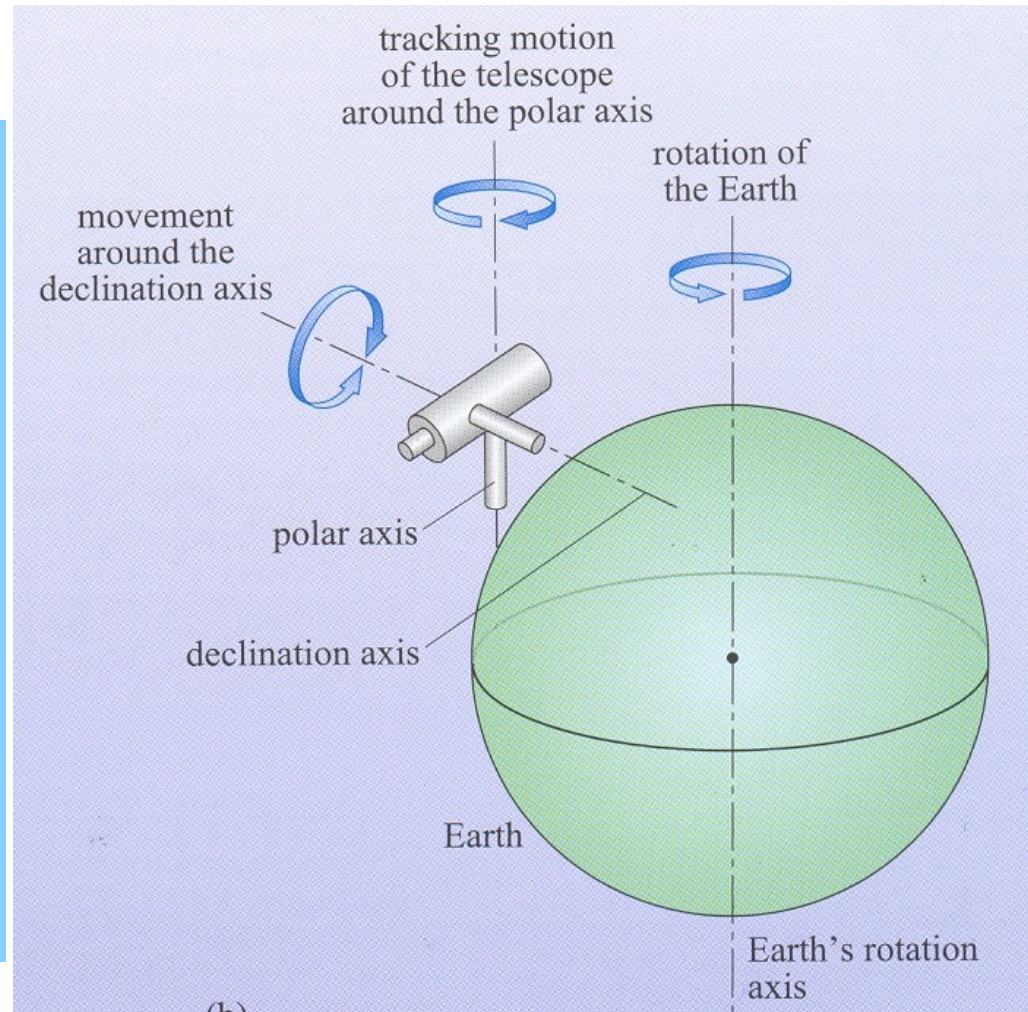
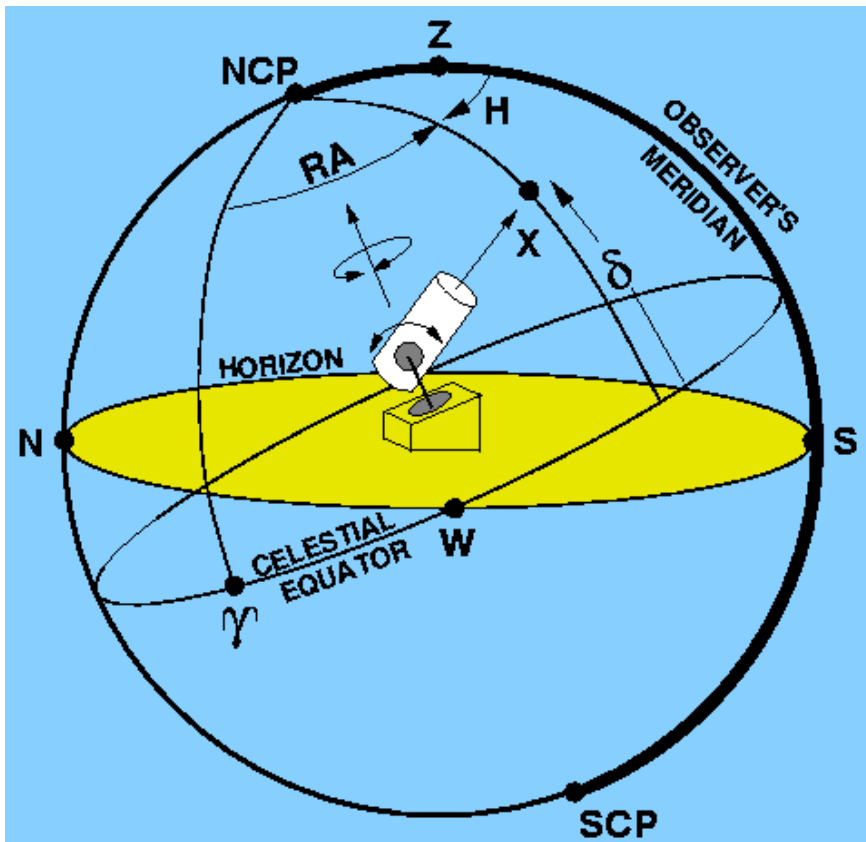

# Equatorial Mounts

- ◆ How do you point a telescope that has an equatorial mount; i.e., about which axis or axes do you have to rotate the telescope?

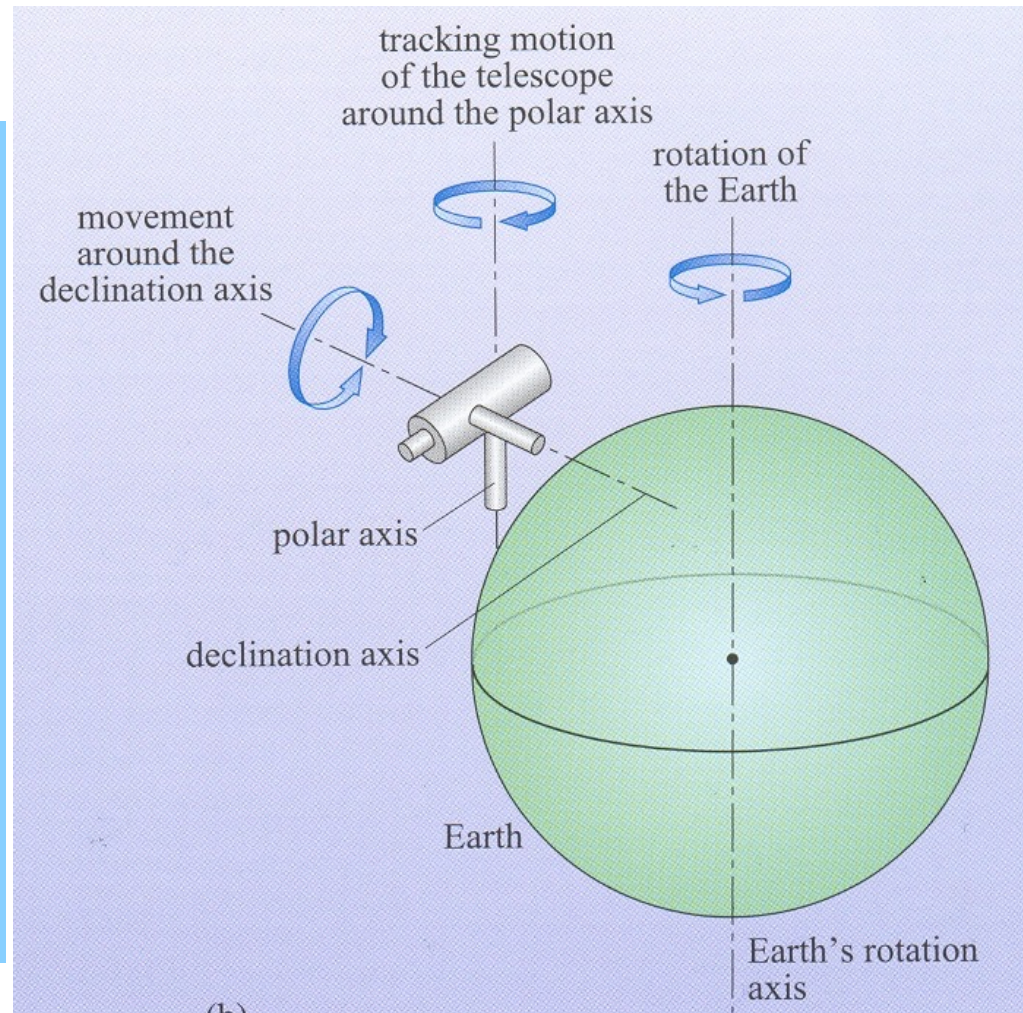
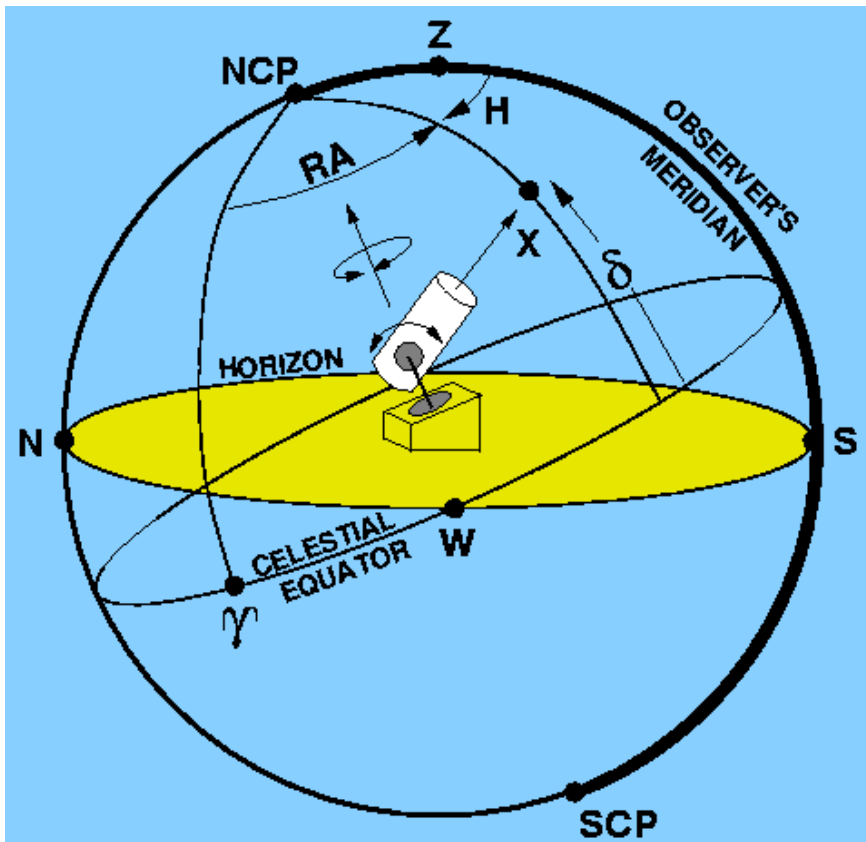

# Equatorial Mounts

- ◆ How do you point a telescope that has an equatorial mount; i.e., about which axis or axes do you have to rotate the telescope? **Both polar and declination axes.**

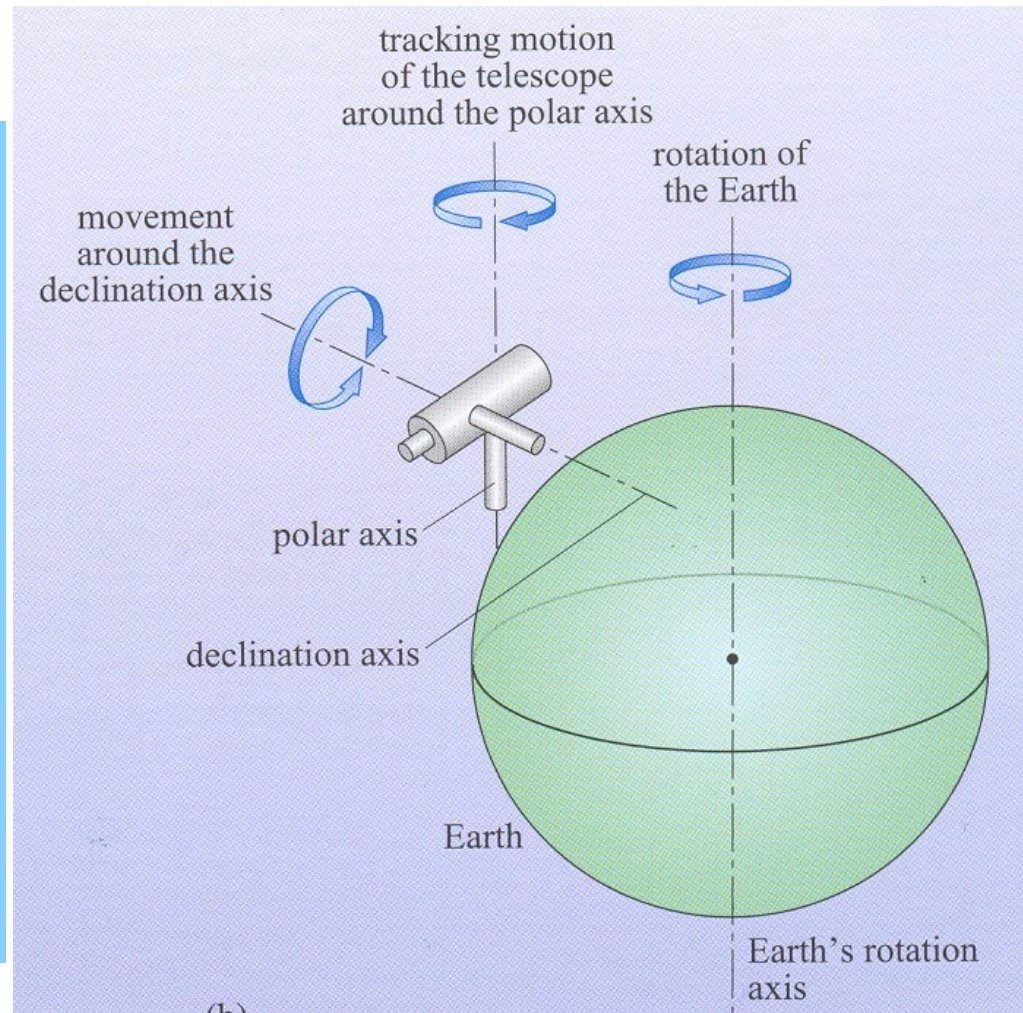
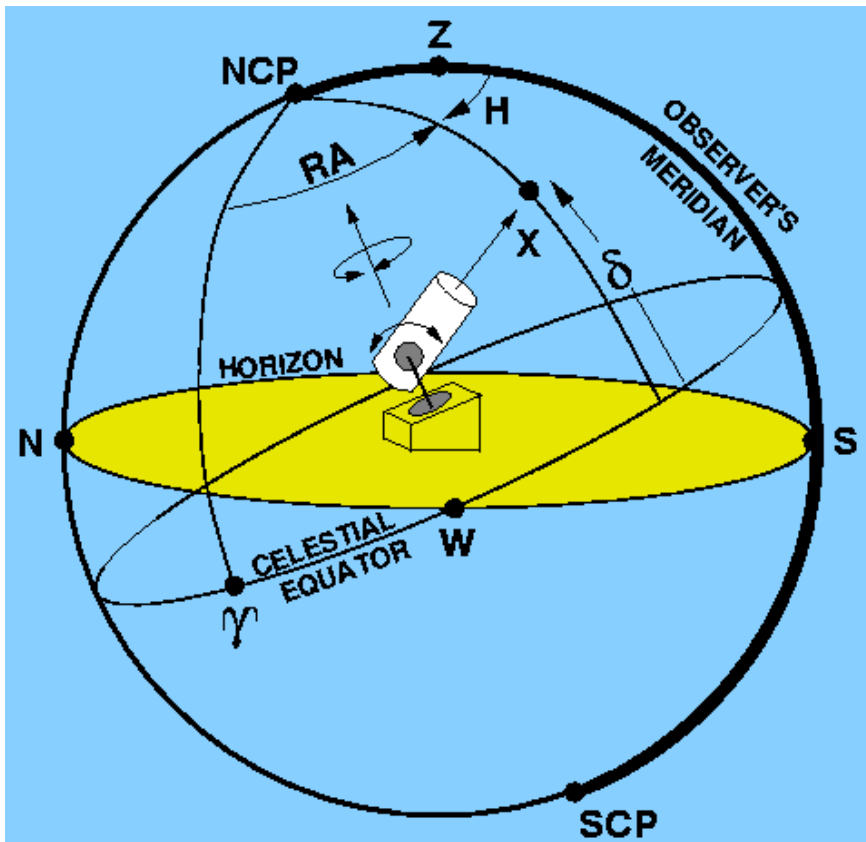

# Equatorial Mounts

- ◆ Once pointed, about which axis or axes do you have to rotate the telescope to track a celestial object?

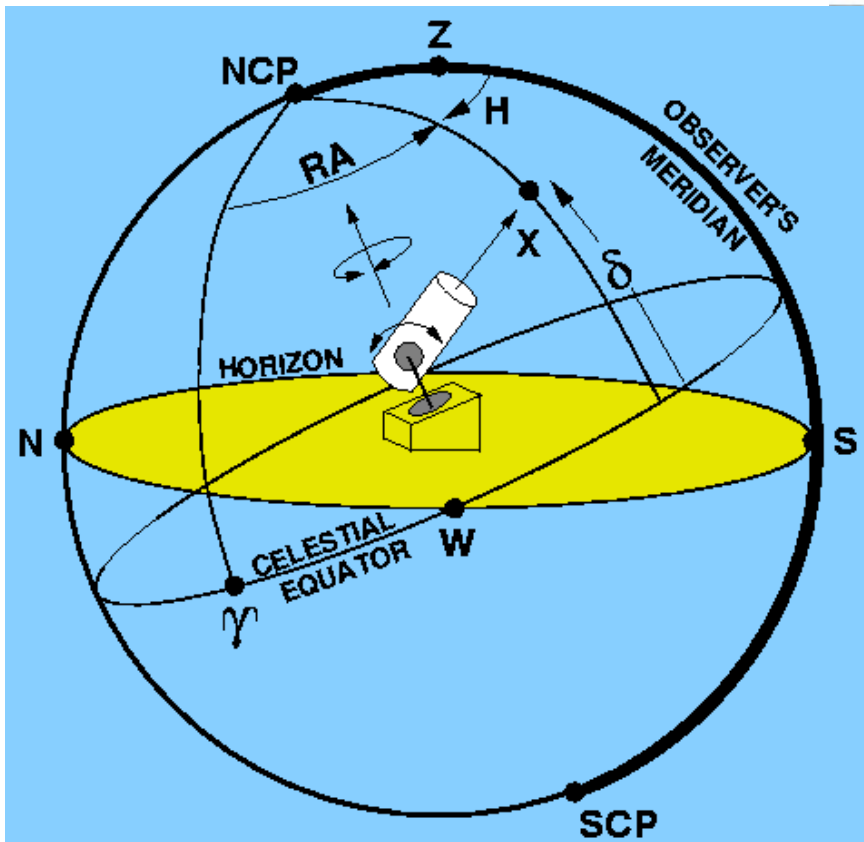



# Equatorial Mounts

---

- ◆ Once pointed, about which axis or axes do you have to rotate the telescope to track a celestial object? Rotate the telescope at a constant speed (the sidereal rate) about the polar axis.

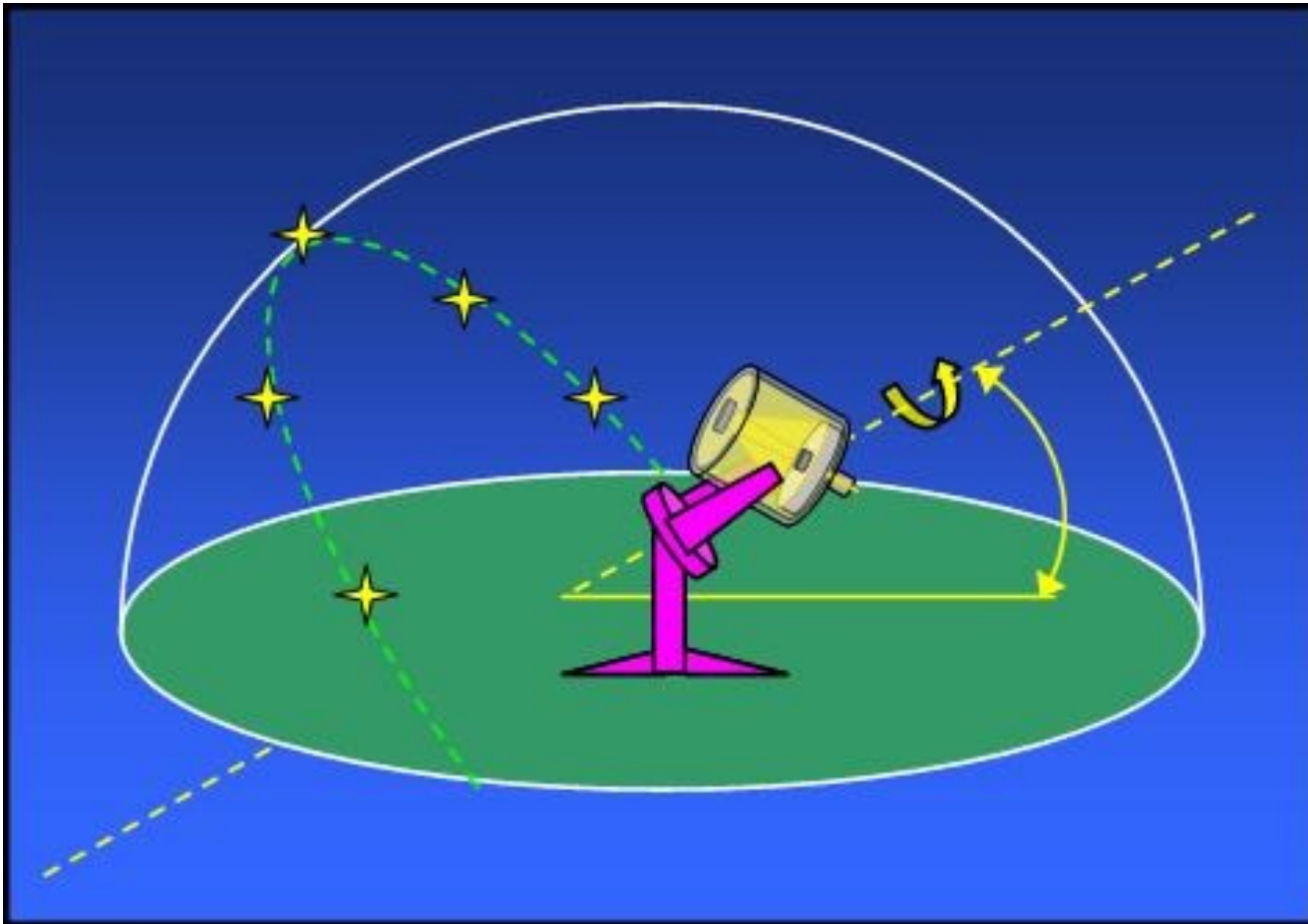

# Equatorial Mounts

---

- ◆ Once pointed, how do you track a celestial object? Rotate the telescope at a constant speed (the sidereal rate) about the polar axis.

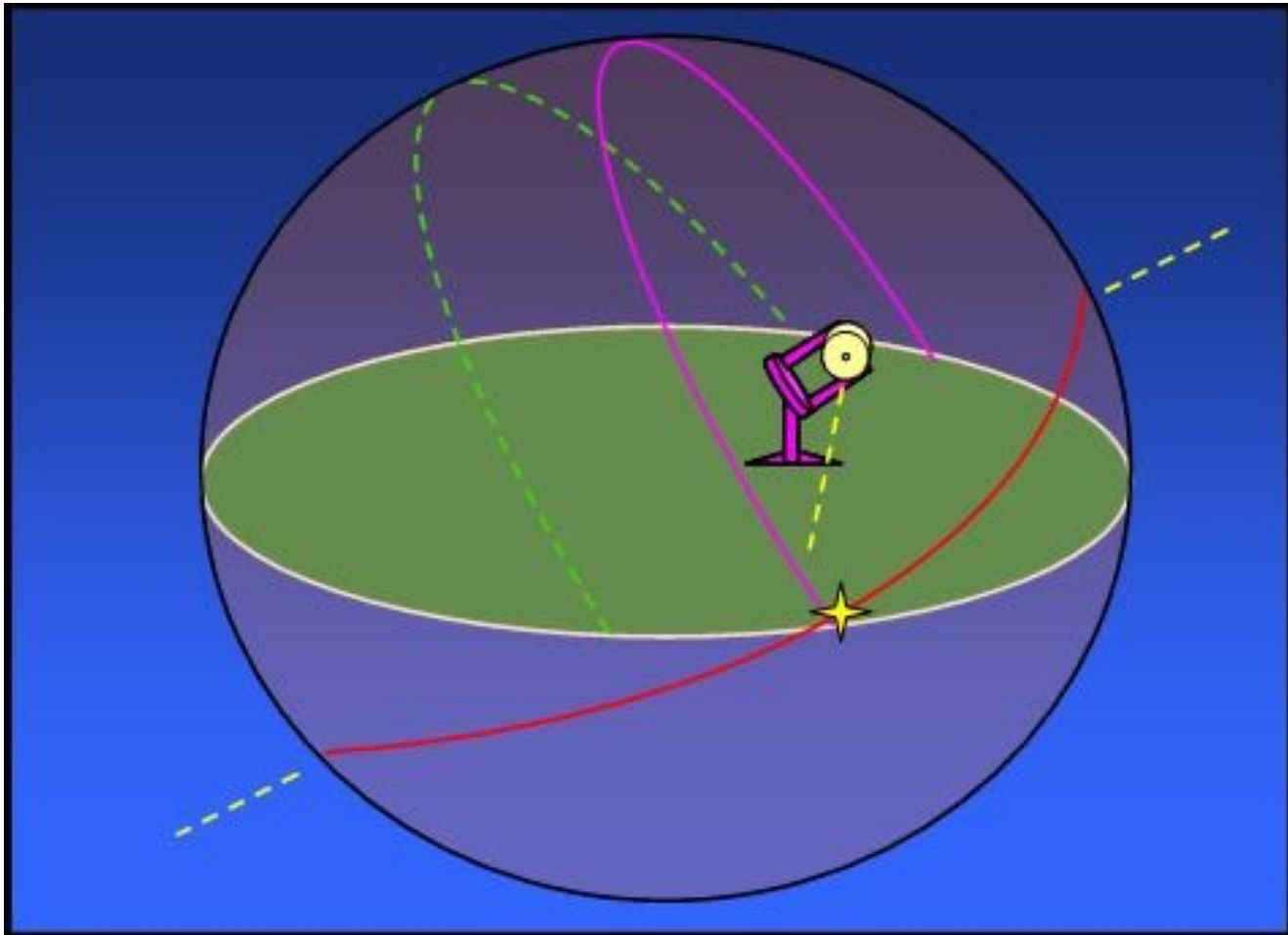

# Equatorial Mounts

---

- ◆ Once pointed, how do you track a celestial object? Rotate the telescope at a constant speed (the sidereal rate) about the polar axis.

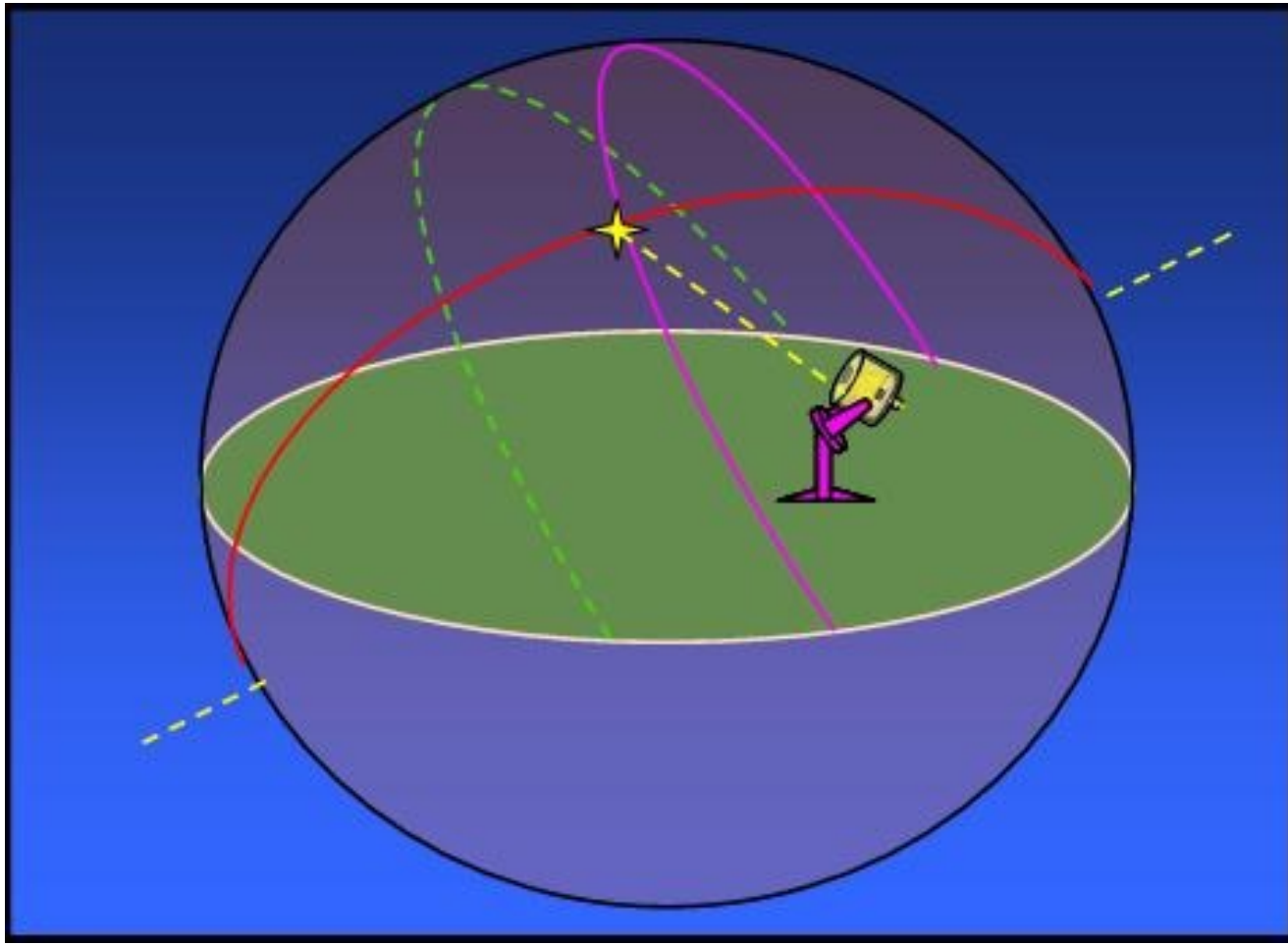

# Equatorial Mounts

---

- ◆ Equatorial mounts are therefore popular among amateur telescopes (especially for astrophotography), as well as in research-class telescopes before the age of computer control.

## 3.6 m Canada-France-Hawaii Telescope (CFHT)

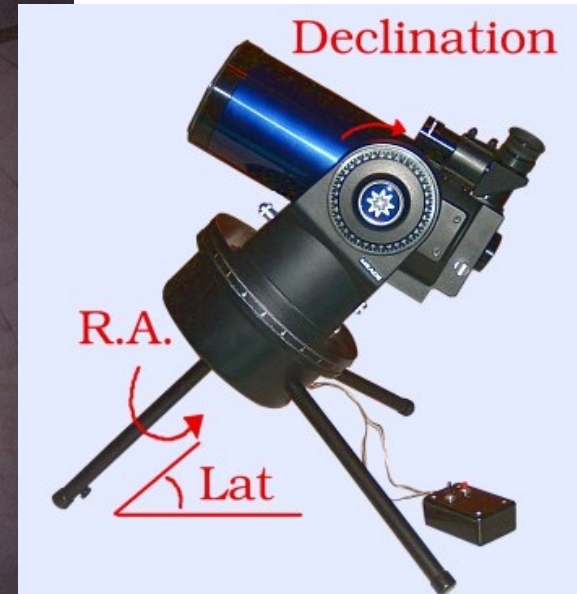

# Altazimuth Mounts

- ◆ Altazimuth mounts have:
  - azimuth axis perpendicular to the ground
  - altitude axis perpendicular to azimuth axis

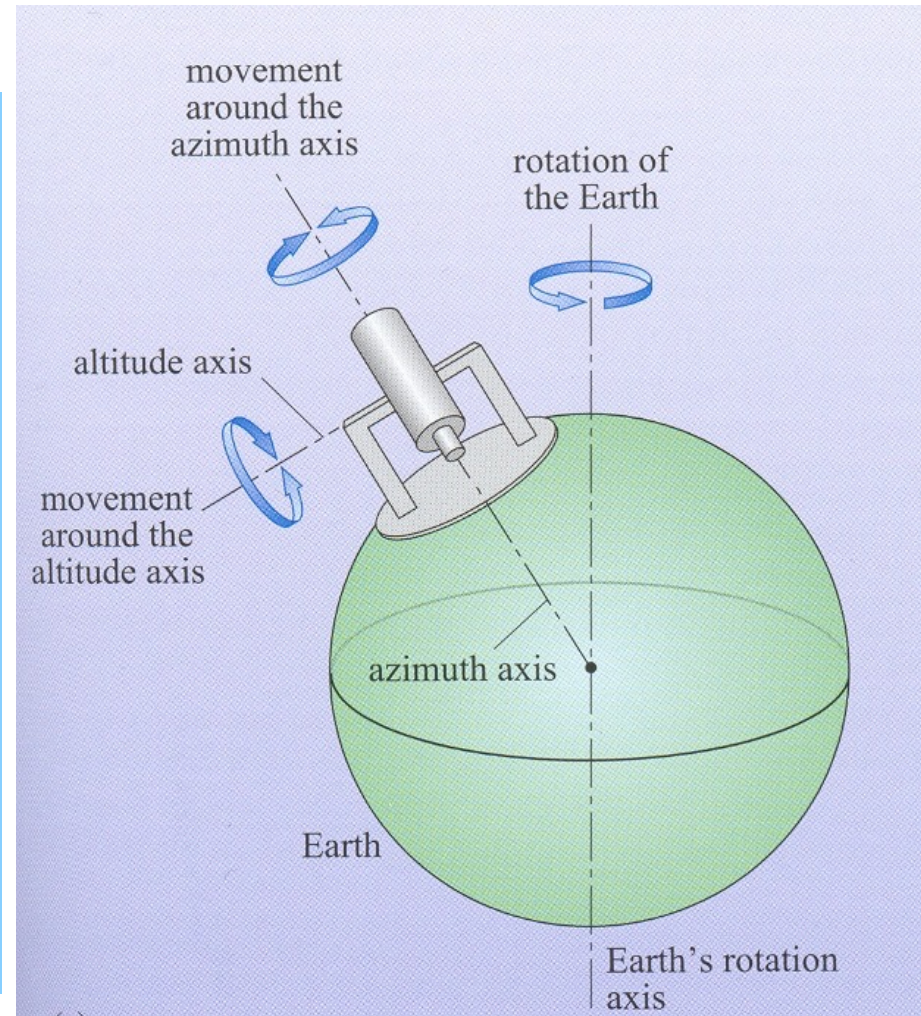
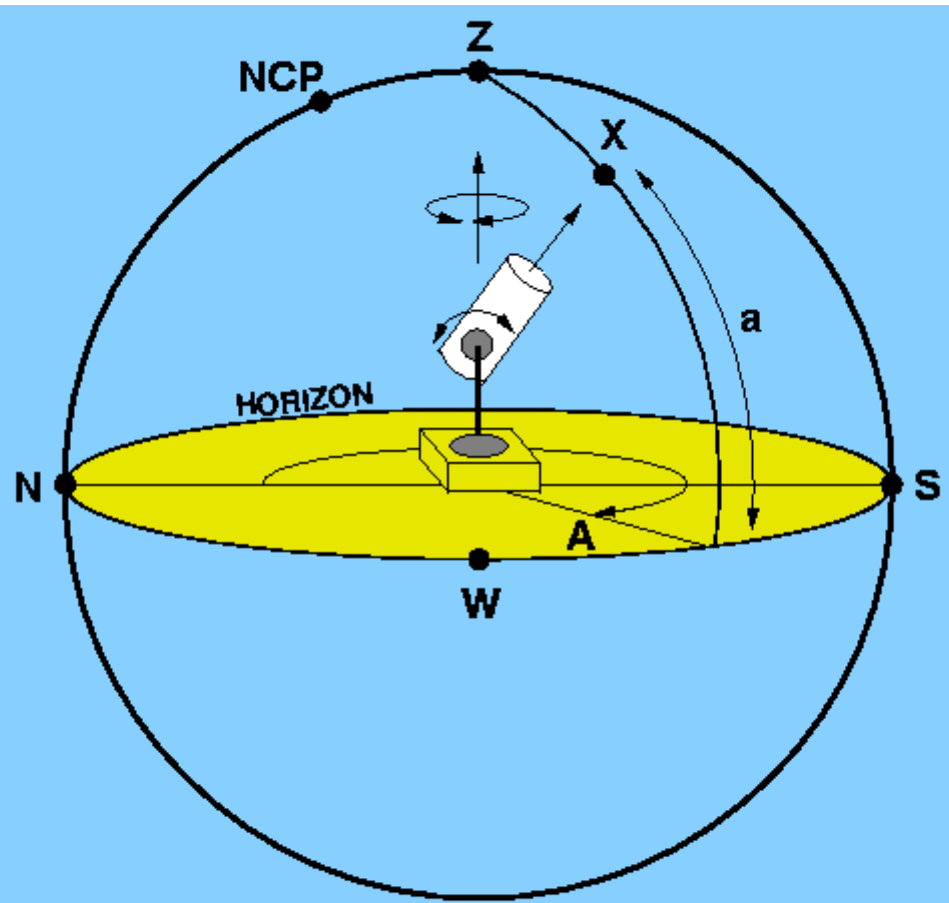

# Altazimuth Mounts

- ◆ How do you point a telescope that has an altzimuth mount; i.e., about which axis or axes do you have to rotate the telescope?

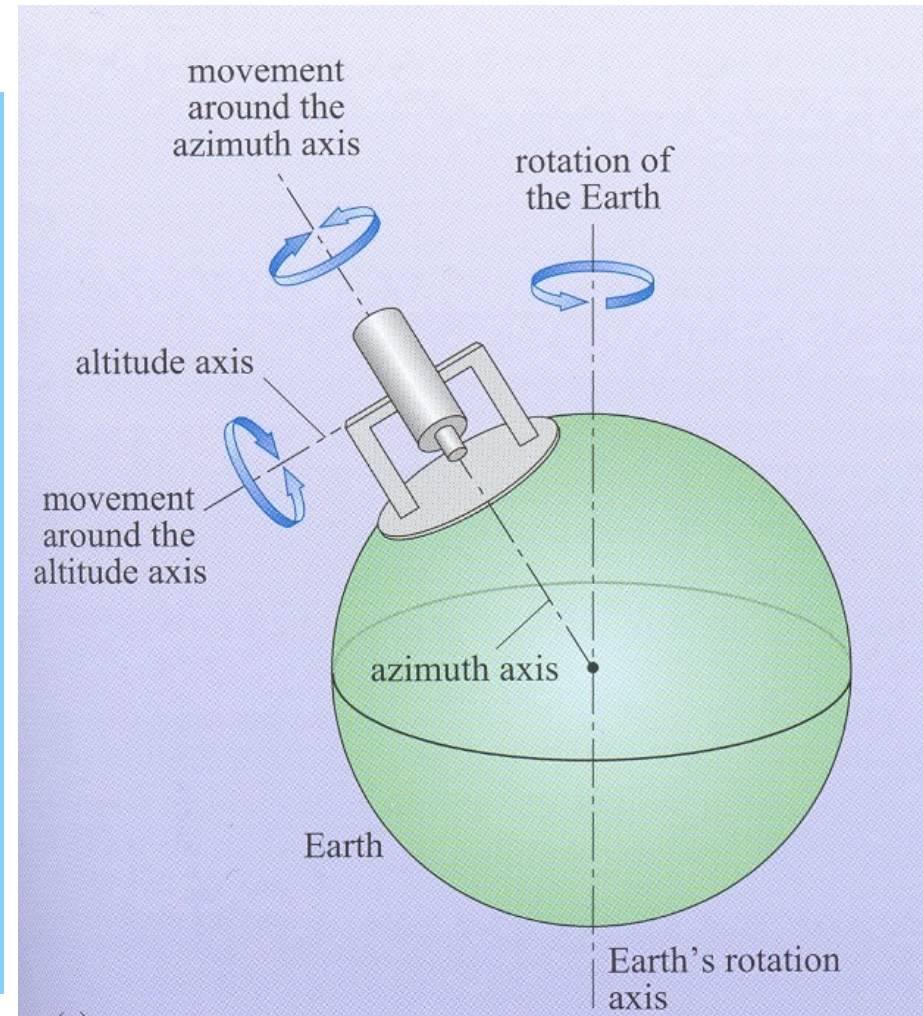
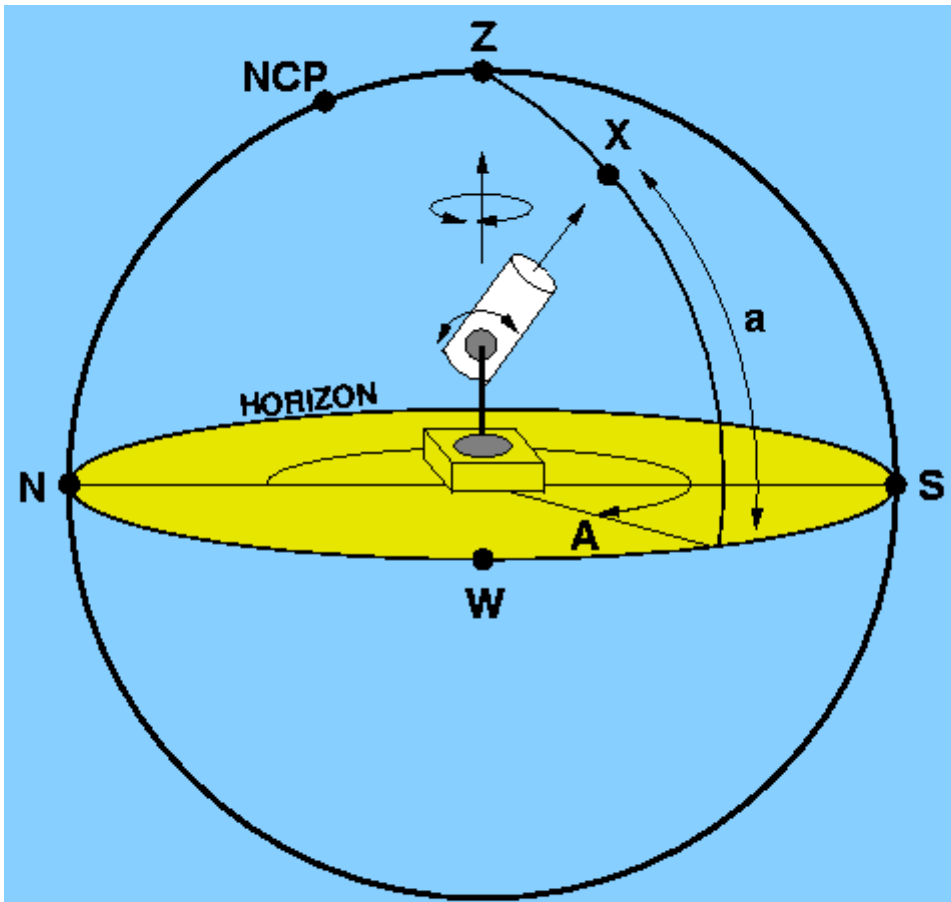

# Altazimuth Mounts

- ◆ How do you point a telescope that has an altzimuth mount; i.e., about which axis or axes do you have to rotate the telescope? **Both azimuth and altitude axes.**

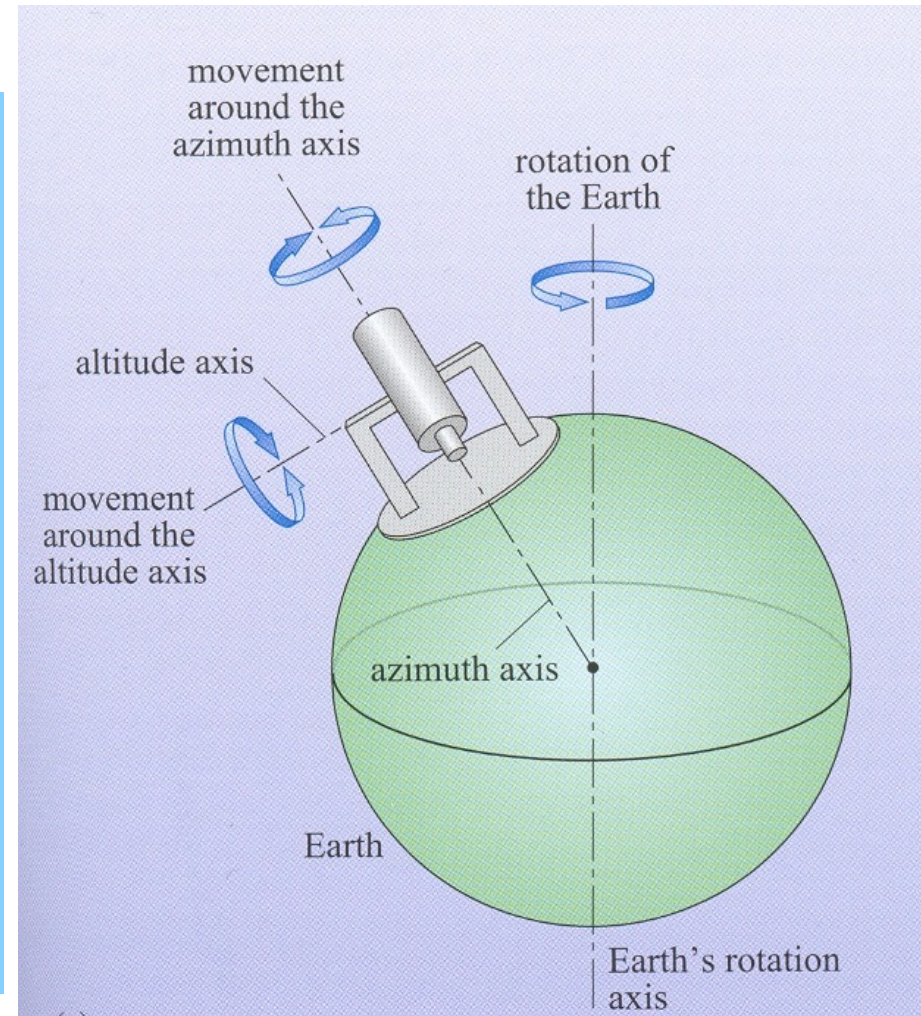
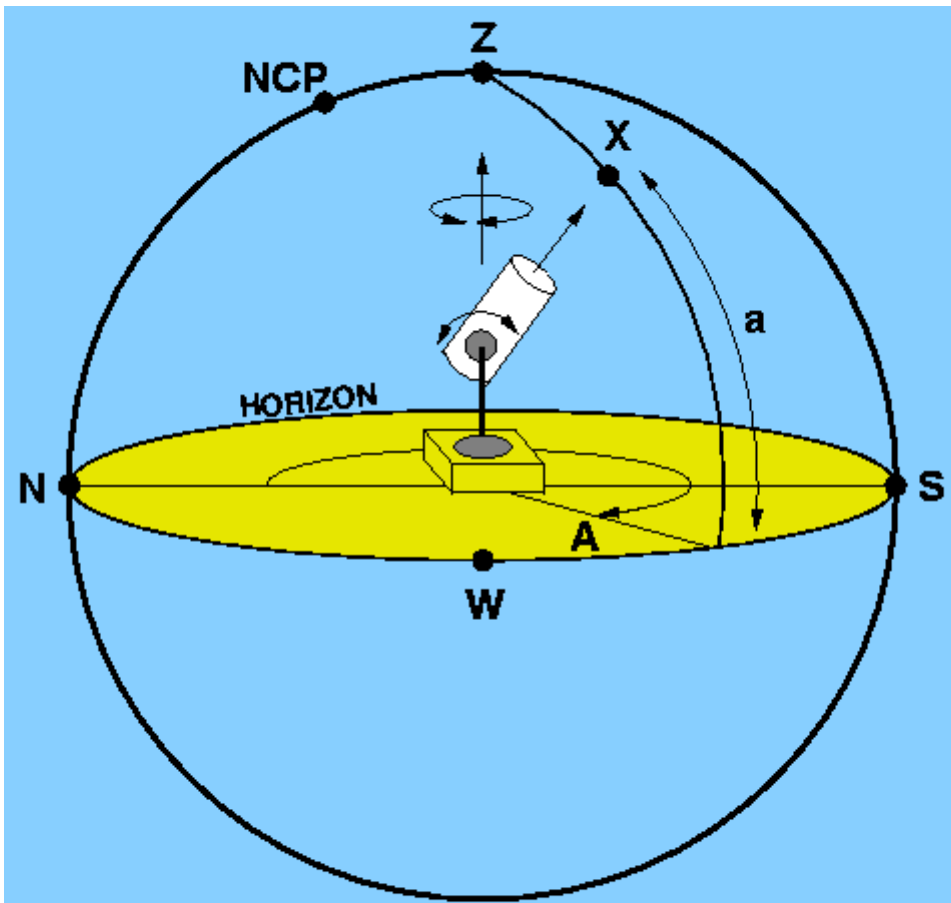

# Altazimuth Mounts

- ◆ How do you point a telescope that has an altzimuth mount; i.e., about which axis or axes do you have to rotate the telescope? **Both azimuth and altitude axes.**
- ◆ Once pointed, how do you track a celestial object?

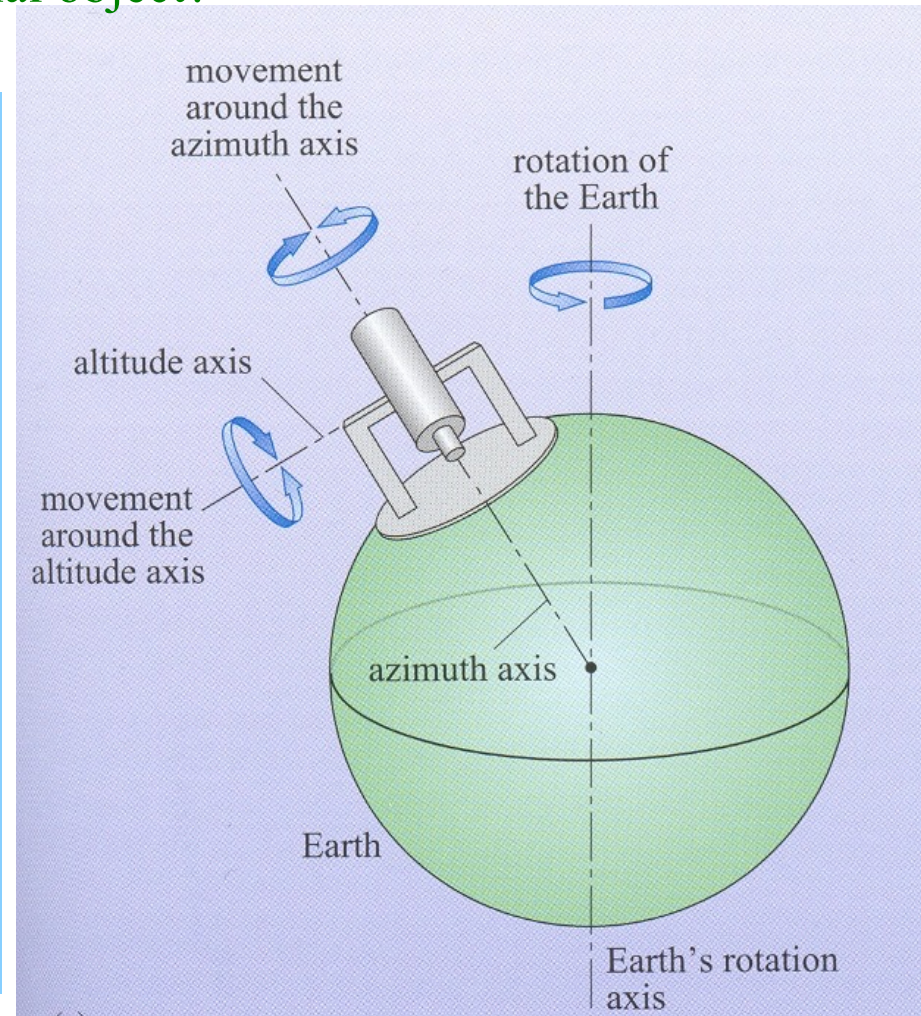
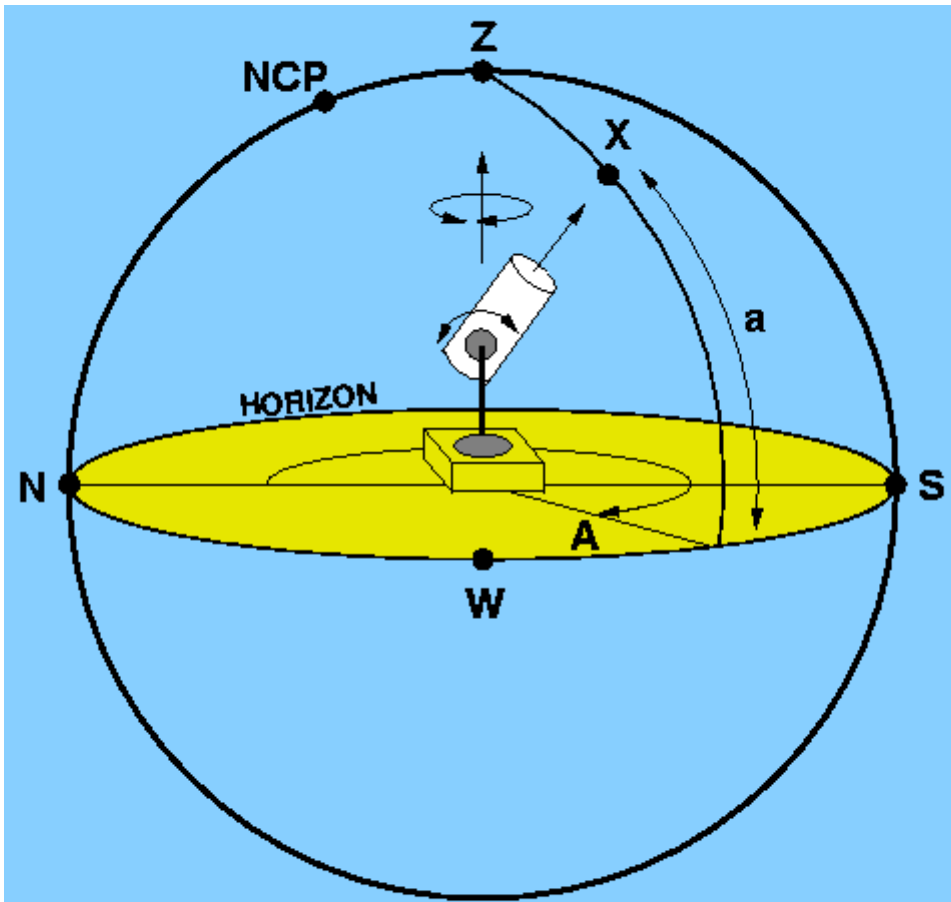



# Altazimuth Mounts

- ◆ How do you point a telescope that has an altzimuth mount; i.e., about which axis or axes do you have to rotate the telescope? **Both azimuth and altitude axes.**
- ◆ Once pointed, how do you track a celestial object? **Rotate the telescope at different variable speeds about both the azimuth and altitude axes.**

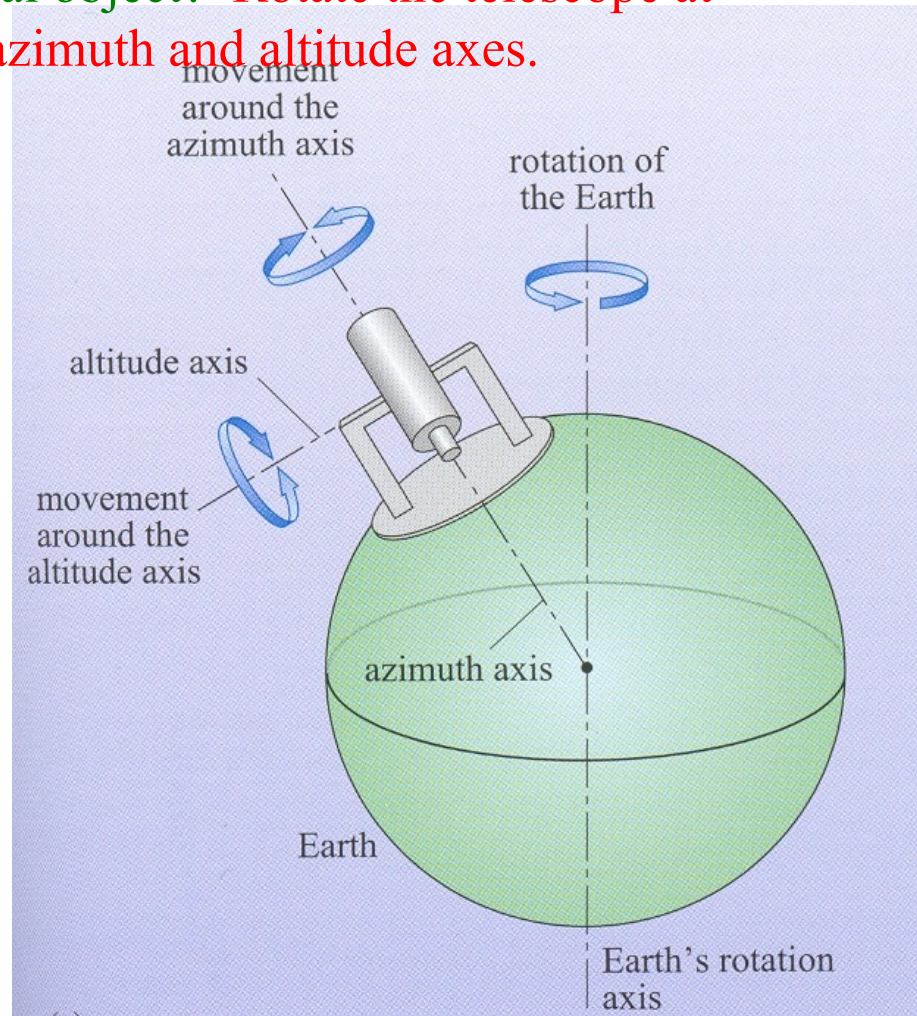
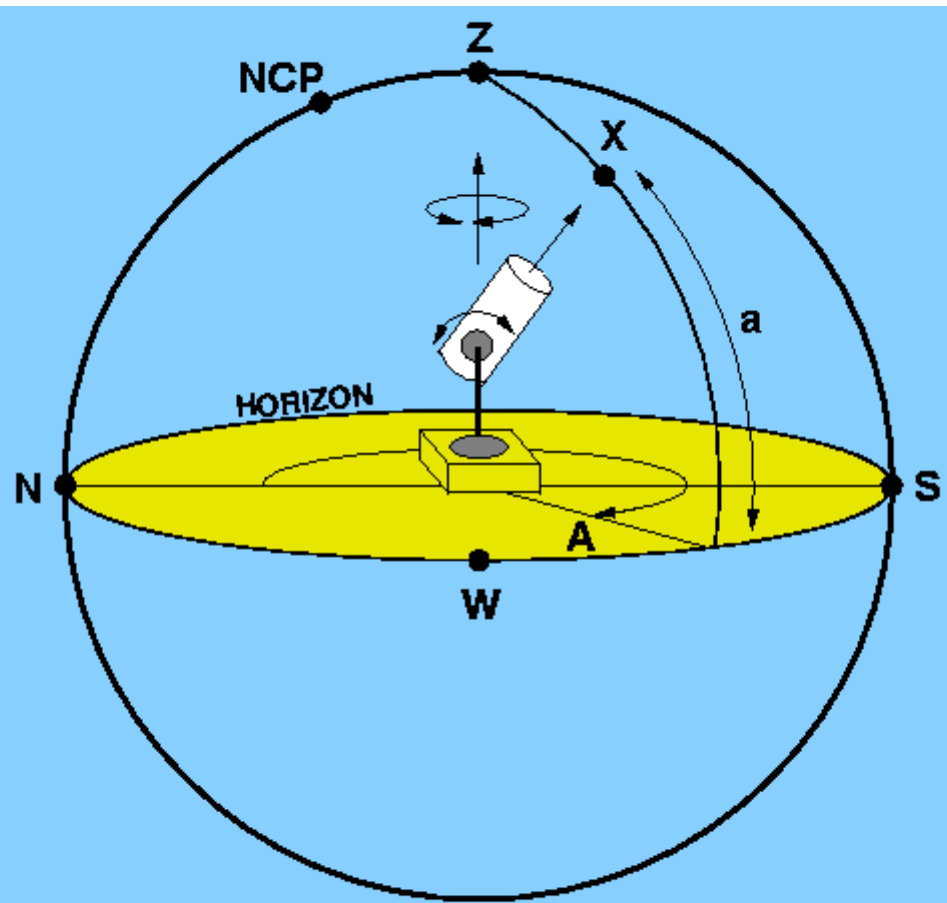

# Altazimuth Mounts

---

- ◆ Altazimuth mounts are popular in simple (inexpensive) amateur telescopes. Today, with computer control, altazimuth mounts also can be used in amateur telescopes for astrophotography.



**Altazimuth Mount**



# Altazimuth Mounts

---

- ◆ Altazimuth mounts used in research-class telescopes since the age of computer control.

8.1 m Gemini Telescope



8.3 m Subaru Telescope



# Equatorial vs Altazimuth Mounts

---

- ◆ Advantages of equatorial over altazimuth mounts:
  - tracking of celestial objects require just one constant-speed motor
  - no image rotation with respect to telescope
- ◆ Notice that orientation of celestial objects changes as the Earth rotates.

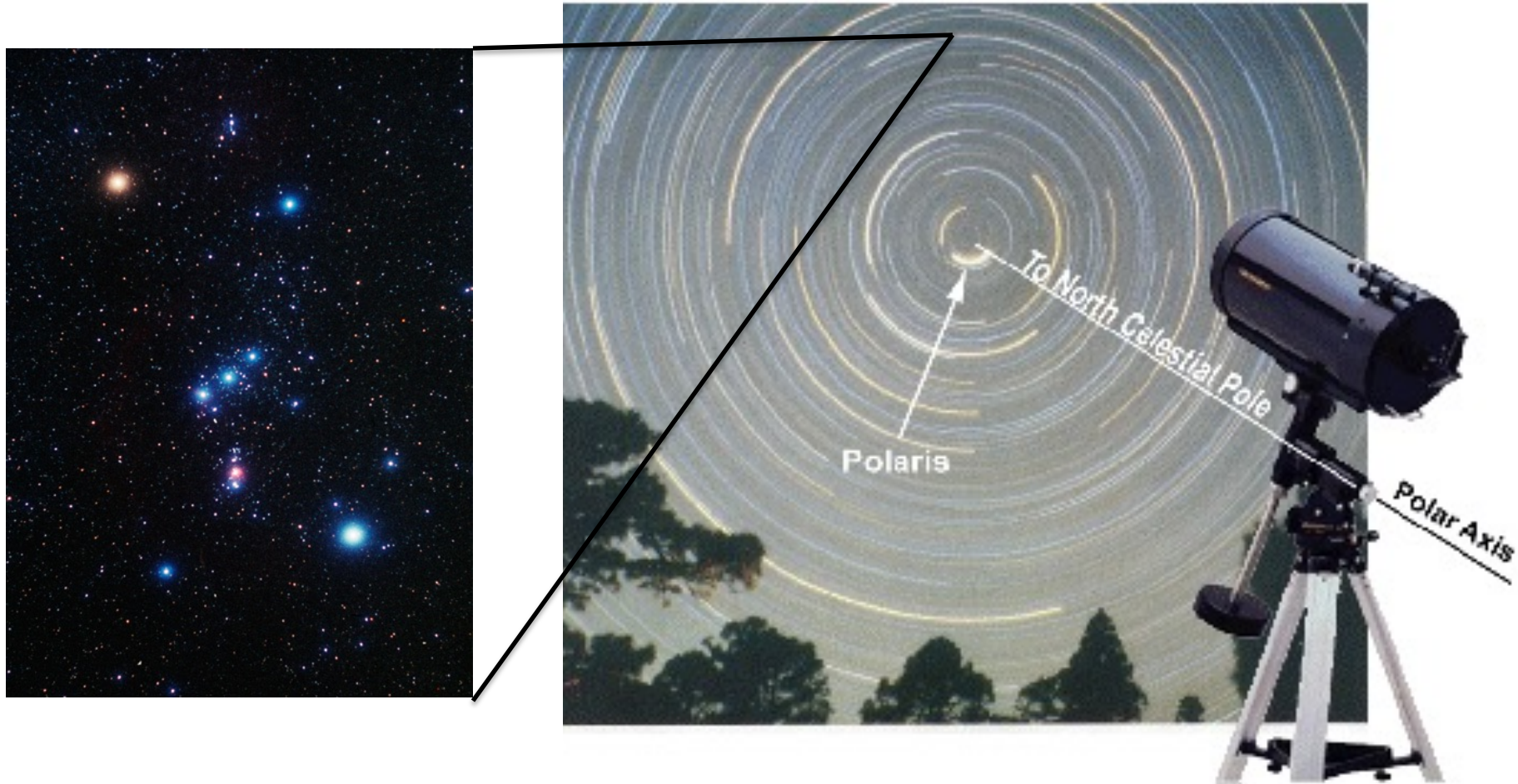

# Equatorial vs Altazimuth Mounts

---

- ◆ Advantages of equatorial over altazimuth mounts:
  - tracking of celestial objects require just one constant-speed motor
  - no image rotation with respect to telescope
- ◆ Notice that orientation of celestial objects changes as the Earth rotates.



# Equatorial vs Altazimuth Mounts

---

- ◆ Advantages of equatorial over altazimuth mounts:
  - tracking of celestial objects require just one constant-speed motor
  - no image rotation with respect to telescope
- ◆ Notice that orientation of celestial objects changes as the Earth rotates.

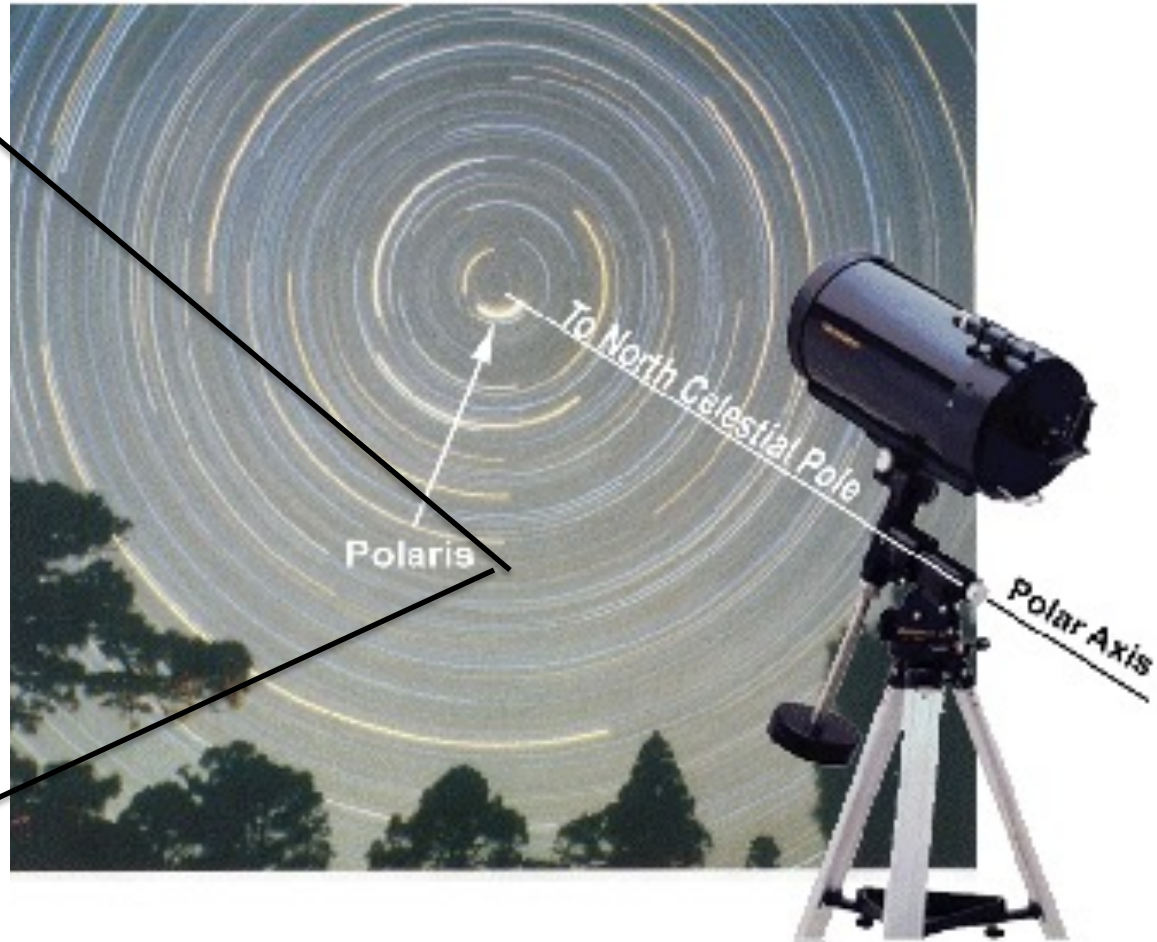

# Equatorial vs Altazimuth Mounts

---

- ◆ Advantages of equatorial over altazimuth mounts:
  - tracking of celestial objects require just one constant-speed motor
  - no image rotation with respect to telescope

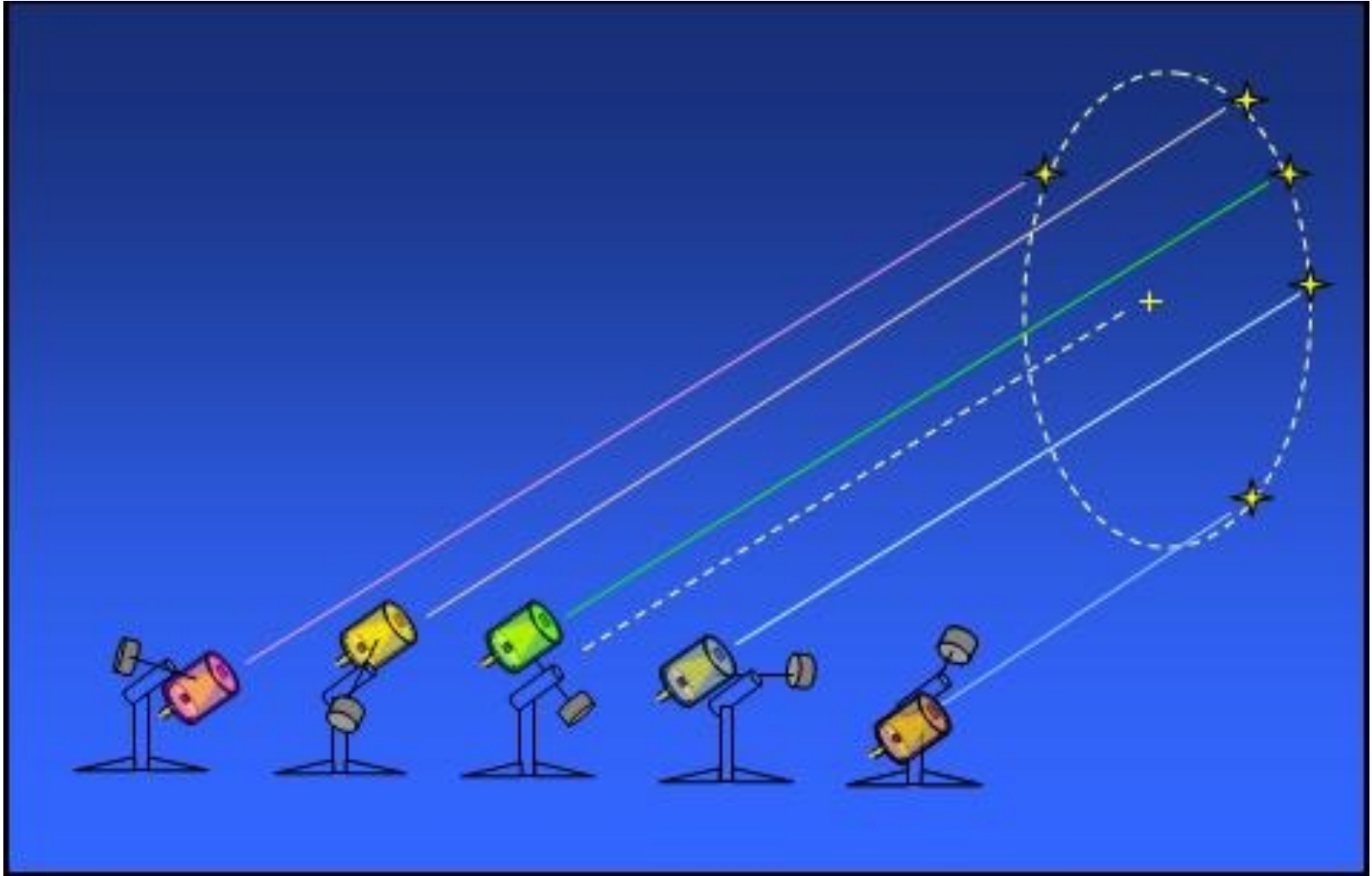

# Equatorial vs Altazimuth Mounts

---

- ◆ Advantages of equatorial over altazimuth mounts:
  - tracking of celestial objects require just one constant-speed motor
  - no image rotation with respect to telescope

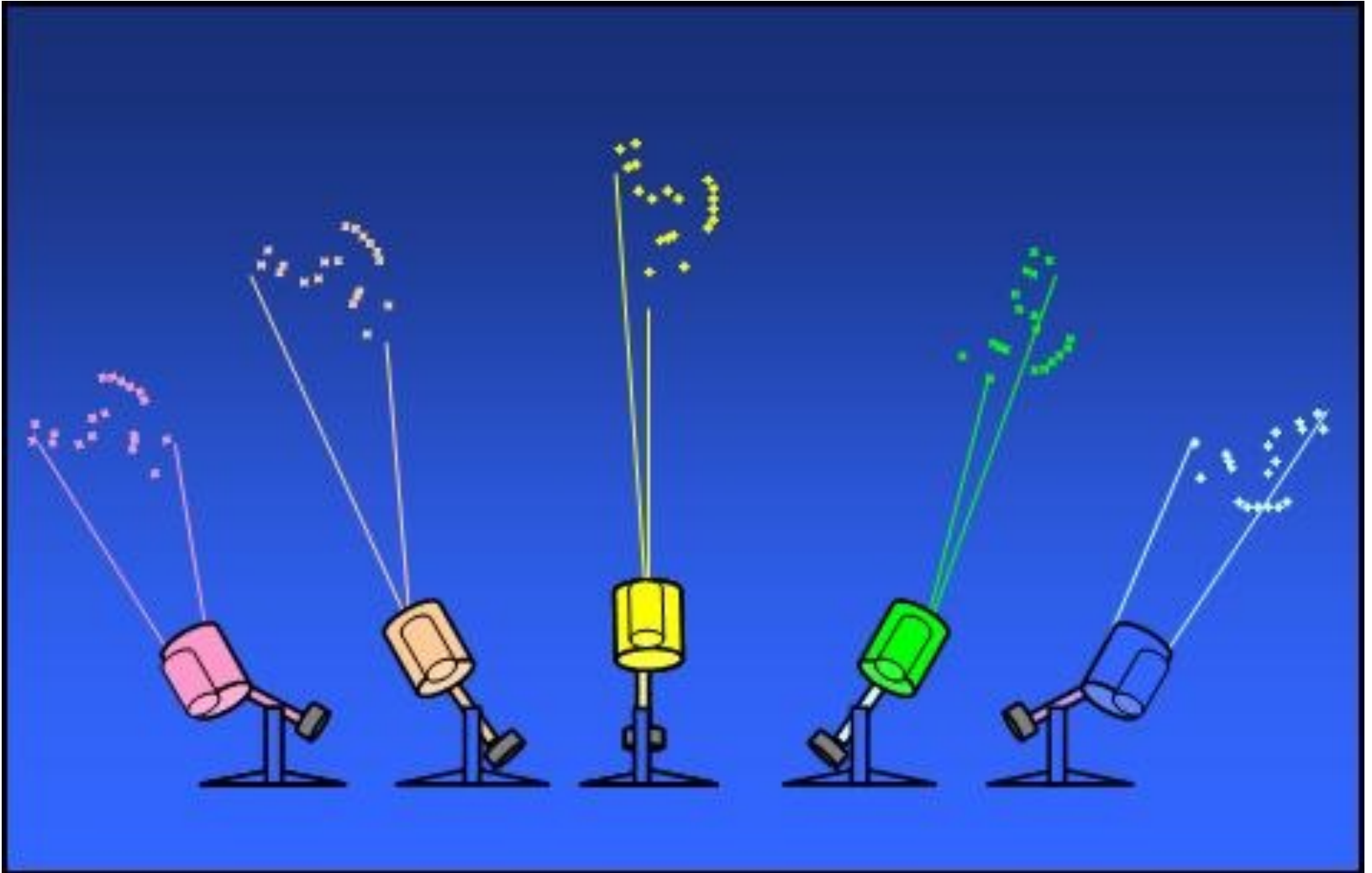



# Equatorial vs Altazimuth Mounts

---

- ◆ Advantages of equatorial over altazimuth mounts:
  - tracking of celestial objects require just one constant-speed motor
  - no image rotation with respect to telescope
- ◆ Disadvantages of equatorial compared with altazimuth mounts:

3.6-m Canada-France-Hawaii Telescope (CFHT)    4.2-m William Herschel Telescope

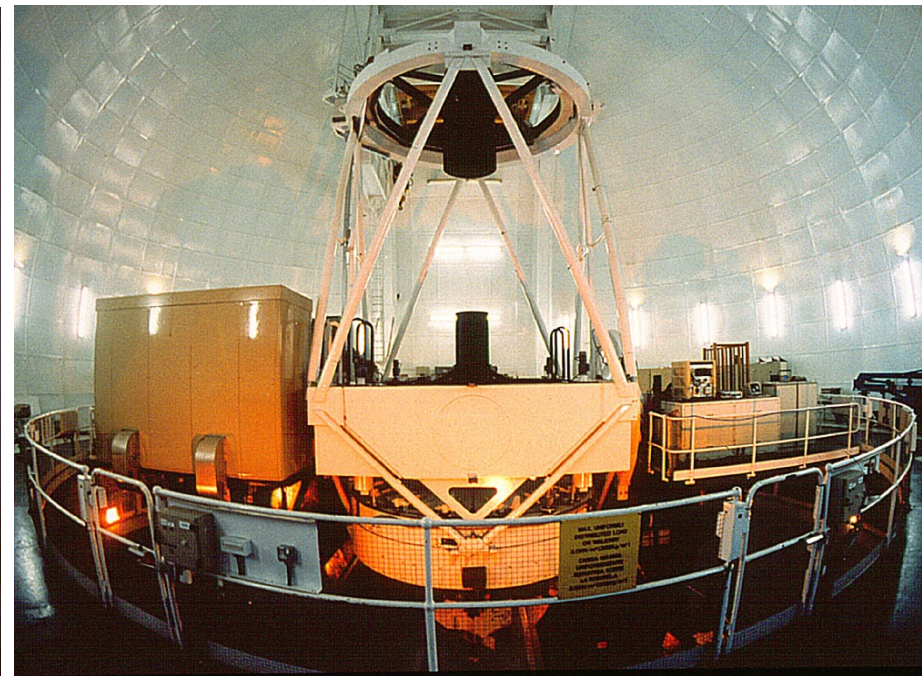

# Equatorial vs Altazimuth Mounts

---

- ◆ Advantages of equatorial over altazimuth mounts:
  - tracking of celestial objects require just one constant-speed motor
  - no image rotation with respect to telescope
- ◆ Disadvantages of equatorial compared with altazimuth mounts:
  - relatively large size/weight of mount thus also requiring relatively large dome

3.6-m Canada-France-Hawaii Telescope (CFHT)    4.2-m William Herschel Telescope

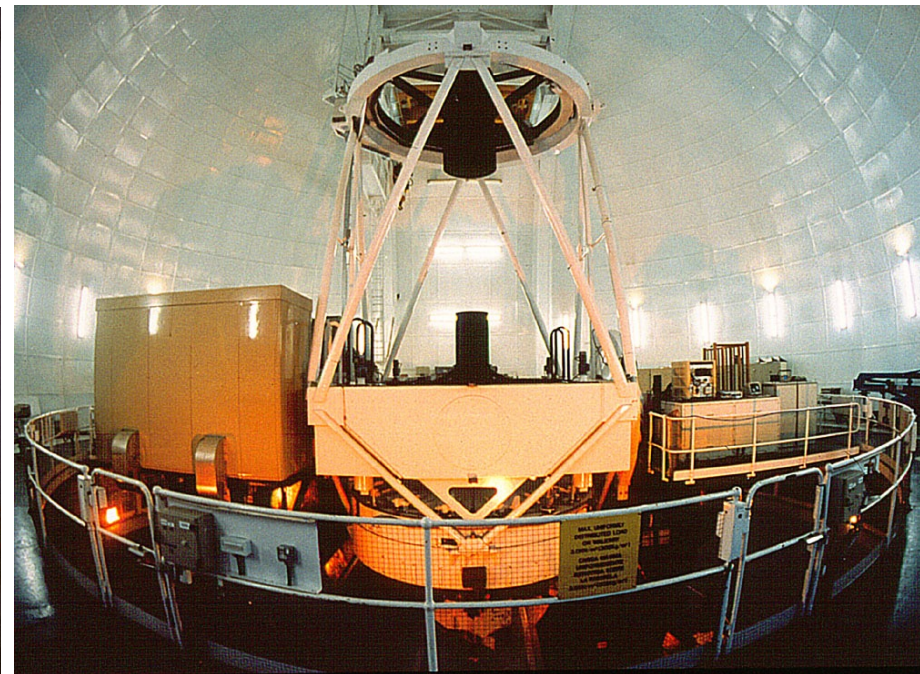

# Equatorial vs Altazimuth Mounts

---

- ◆ Advantages of equatorial over altazimuth mounts:
  - tracking of celestial objects require just one constant-speed motor
  - no image rotation with respect to telescope
- ◆ Disadvantages of equatorial compared with altazimuth mounts:
  - relatively large size/weight of mount thus also requiring relatively large dome

3.6-m Canada-France-Hawaii Telescope (CFHT)



# Equatorial vs Altazimuth Mounts

---

- ◆ Advantages of equatorial over altazimuth mounts:
  - tracking of celestial objects require just one constant-speed motor
  - no image rotation with respect to telescope
- ◆ Disadvantages of equatorial compared with altazimuth mounts:
  - relatively large size/weight of mount thus also requiring relatively large dome
  - unbalanced design, requires counterweight (unless motor can counter weight of telescope tube)

3.6-m Canada-France-Hawaii Telescope (CFHT)



# Equatorial vs Altazimuth Mounts

- ◆ Advantages of altazimuth over equatorial mounts:
  - relatively small size/weight of mount thus also requiring relatively small dome
  - balanced design

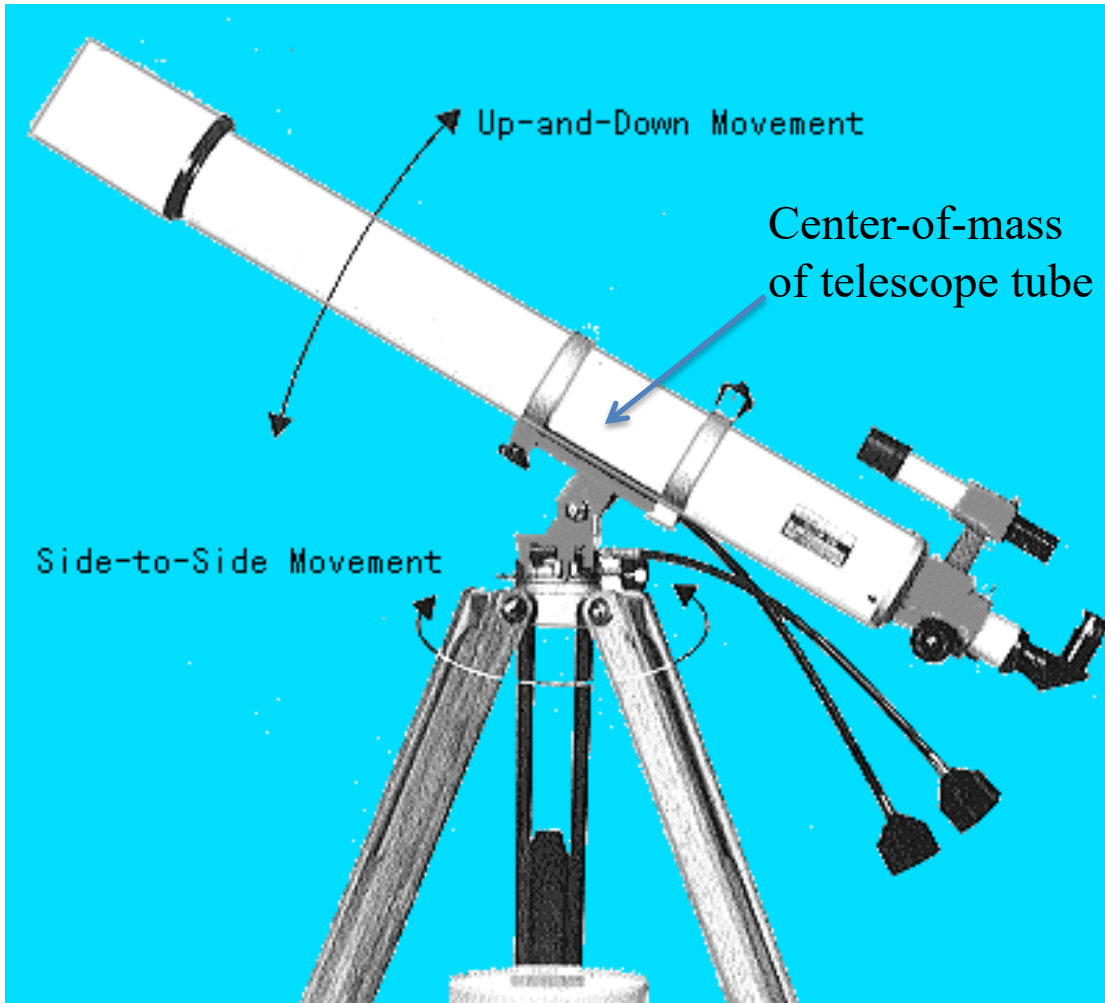

8.3 m Subaru Telescope



# Equatorial vs Altazimuth Mounts

---

- ◆ Advantages of altazimuth over equatorial mounts:
  - relatively small size/weight of mount thus also requiring relatively small dome
  - balanced design
- ◆ Disadvantages of altazimuth compared with equatorial mounts:
  - tracking of celestial objects require two variable-speed motors
  - image rotation with respect to telescope

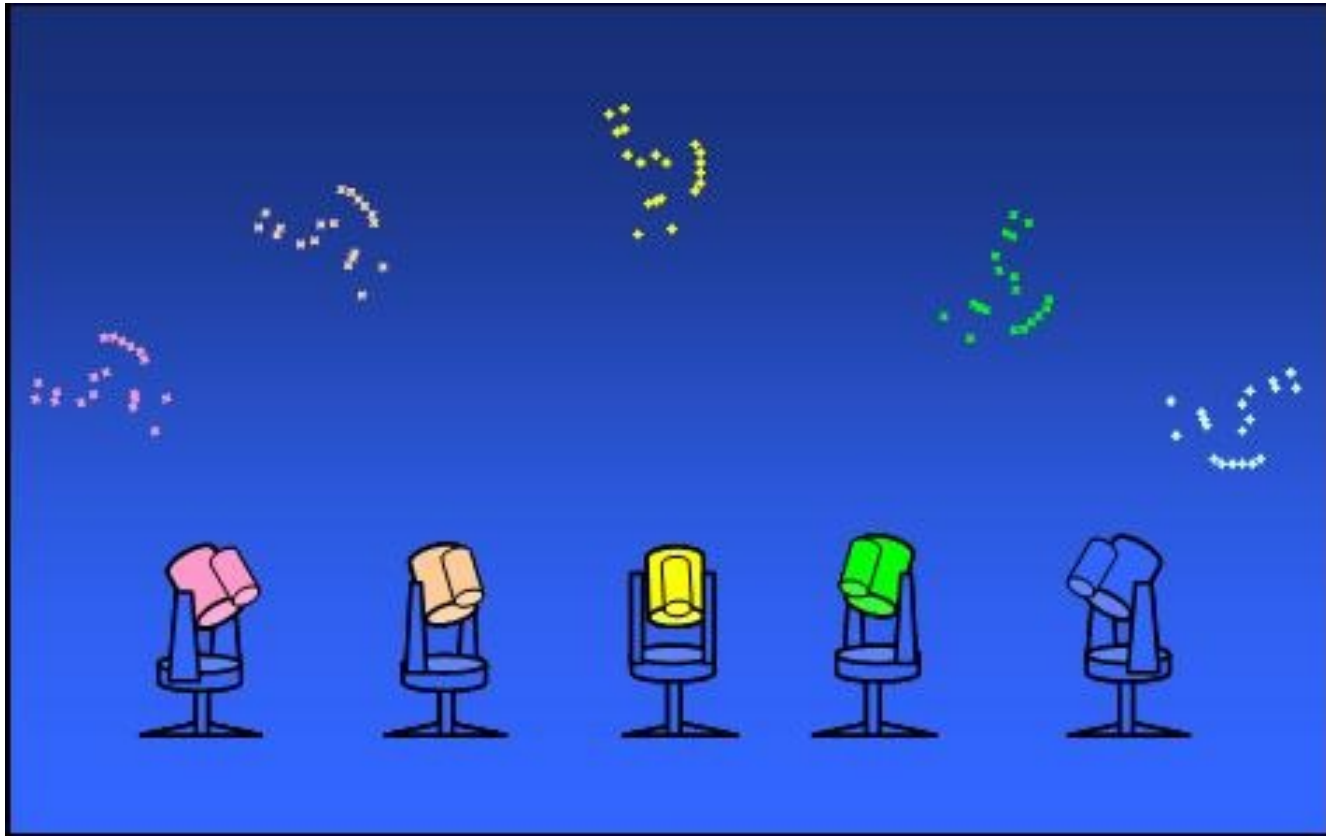

# Equatorial vs Altazimuth Mounts

---

- ◆ How can problem of image rotation be addressed in telescopes using altazimuth mounts?

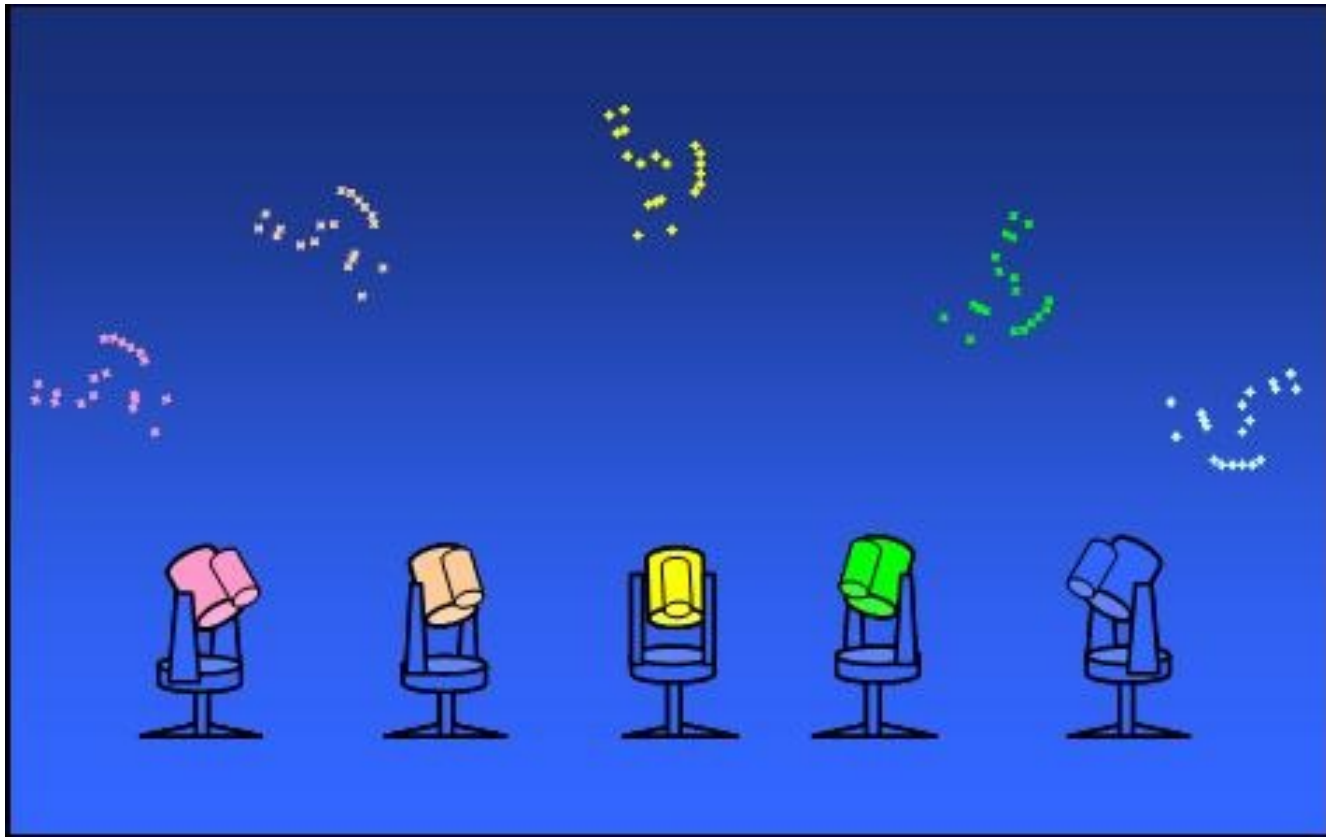

# Equatorial vs Altazimuth Mounts

---

- ◆ How can problem of image rotation be addressed in telescopes using altazimuth mounts? **Use a field derotator.**

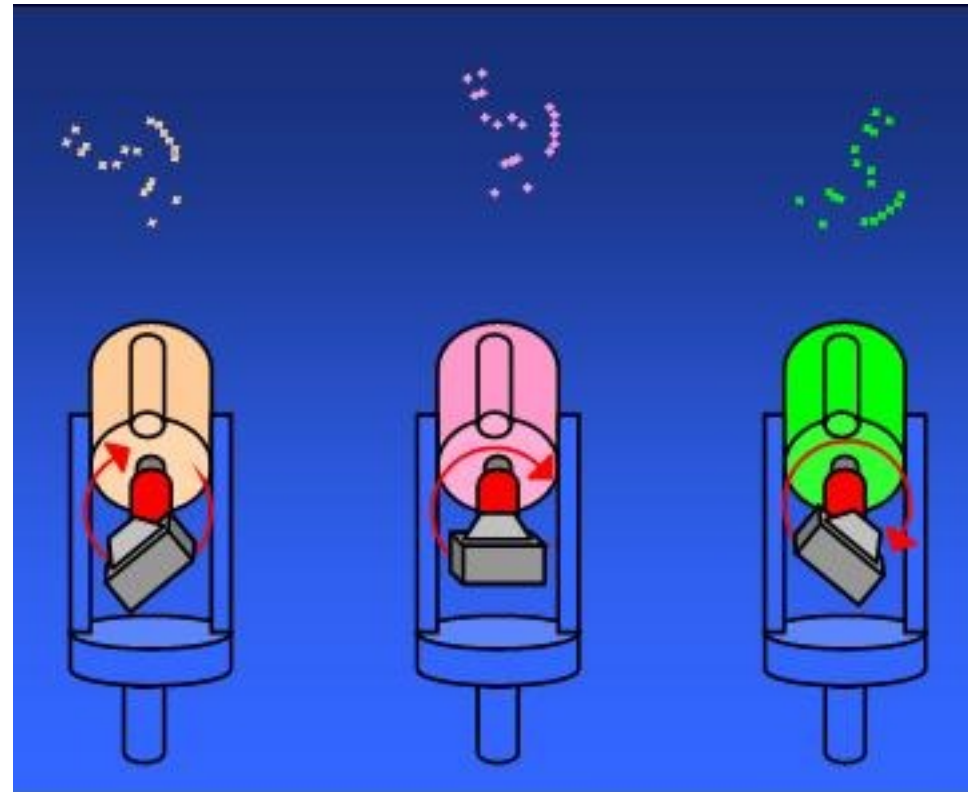



# Learning Objectives

---

- ◆ Optical Aberrations:
  - field curvature
  - spherical aberration
  - coma
  - astigmatism
  - distortion
  - chromatic aberration
  
- ◆ Telescope Configurations:
  - refractors
  - reflectors (Prime, Newtonian, Cassegrain, Coudé or Nasmyth, Schmidt, Schmidt-Cassegrain, Maksutov-Cassegrain)
  
- ◆ Telescope Mounts:
  - equatorial
  - altazimuth
  
- ◆ Telescope Dome and Observatory Site

# Telescope Dome

---

- ◆ What are the functions of a telescope dome?

Backyard Telescope Dome



3.6-m Canada-France-Hawaii Telescope (CFHT)



# Telescope Dome

---

## ◆ What are the functions of a telescope dome?

- protects telescopes that cannot be moved against the weather
- protects a telescope against wind

Backyard Telescope Dome



3.6-m Canada-France-Hawaii Telescope (CFHT)



# Observatory Site

- ◆ Where are the best sites on Earth to locate optical and near-IR telescopes?

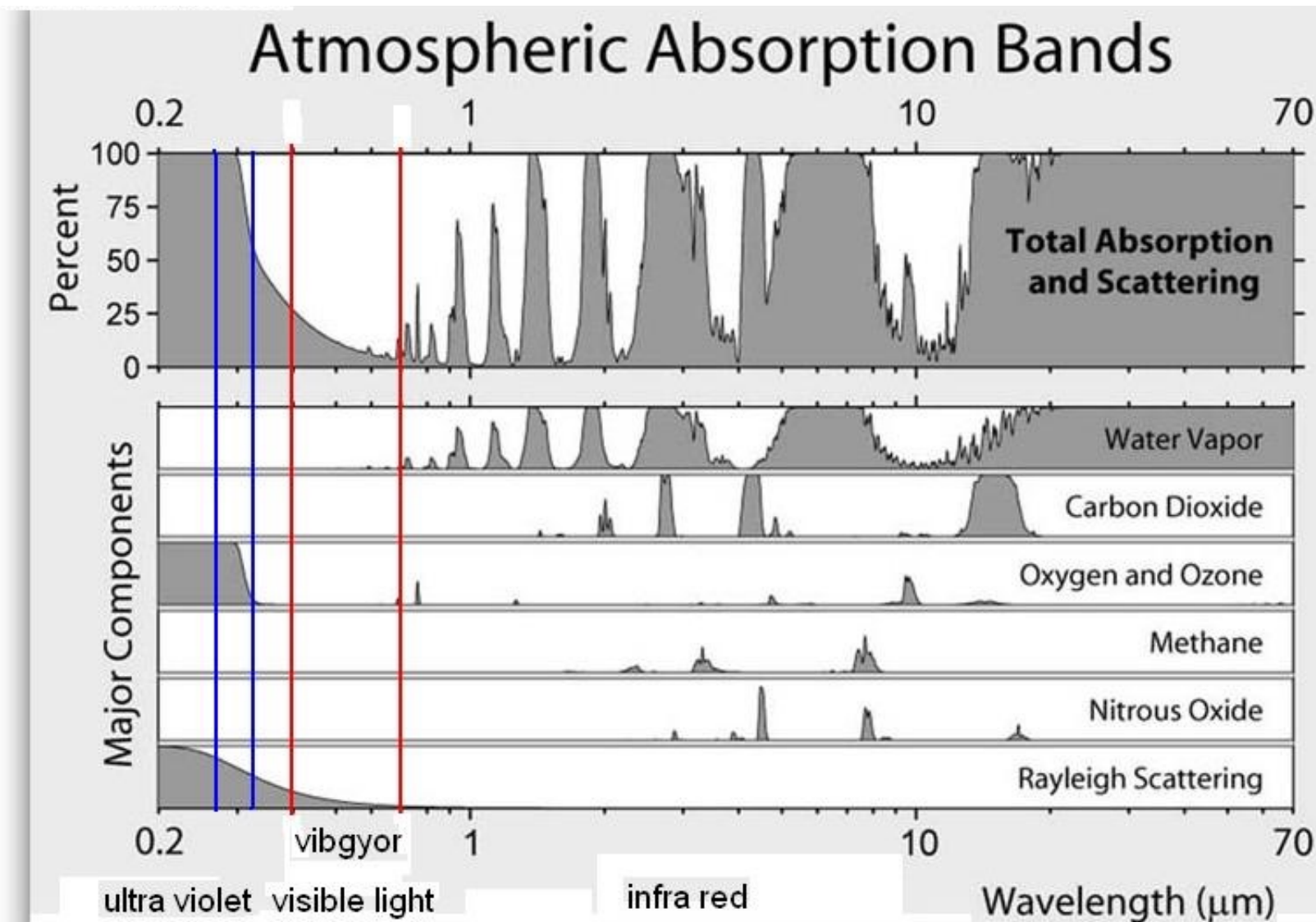

# Observatory Site

---

- ◆ Where are the best sites on Earth to locate optical and near-IR telescopes?
  - low cloud cover (i.e., dry site)
  - as high as possible to minimize Rayleigh scattering (optical) and absorption by water vapour (near-IR)
- ◆ Prime site in northern hemisphere is Mauna Kea (altitude 4.2 km) in Hawaii.



# Observatory Site

---

- ◆ Where are the best sites on Earth to locate optical and near-IR telescopes?
  - low cloud cover (i.e., dry site)
  - as high as possible to minimize Rayleigh scattering (optical) and absorption by water vapour (near-IR)
- ◆ Prime site in southern hemisphere is Andes mountains (altitude  $\geq 2.8$  km) in Chile.

