

Heating plants

HVAC System design

Marco Manzan

University of Trieste
Department of Engineering and Architecture

March 2026

Air conditioning systems

- ① liquid (**water or water with additives**), are suitable for controlling only the internal temperature and not the humidity; they are sized based on the sensible load, they are usually used for heating and cooling.
They can be of three different types:
 - radiators (winter use only)
 - fan coils (winter and summer use)
 - radiant panels (winter for heating and summer for cooling).
- ② direct expansion **systems** (winter and summer use and for small and medium powers).
- ③ all-air **systems**, are suitable for controlling both the temperature and the internal humidity; can be divided in turn
 - single duct
 - double duct
 - constant or variable flow rate
- ④ Mixed systems **air and water**
 - water part controls the temperature
 - air part controls the humidity

Classical use for heating, heat exchange by

- radiation about 30 %
- convection about 70 %

The thermal output depends on the difference between the average temperature of the radiator and the ambient air

$$\Phi = c(\Delta\theta_a)^n$$

c is a typical coefficient of the radiator

$n \sim 4/3$ for convection in turbulent regime

$\Delta\theta_a$ average temperature difference between the radiator and ambient air:

heat output change with temperature

The difference between the average temperature of the radiator and the air can be expressed as:

$$\Delta\theta_a = \left[\frac{(\theta_m + \theta_r)}{2} - \theta_{air} \right]$$

θ_m inlet temperature

θ_r outlet temperature

according to UNI EN 442 the heat flux is calculated in nominal conditions with $\Delta\theta_a = \Delta\theta_n$ with $\theta_{aria} = 20^\circ$:

$$\left. \begin{array}{l} \theta_m = 85^\circ \text{C} \\ \theta_r = 75^\circ \text{C} \end{array} \right\} \implies \Delta\theta_n = 60 \text{ K}$$

$$\left. \begin{array}{l} \theta_m = 75^\circ \text{C} \\ \theta_r = 65^\circ \text{C} \end{array} \right\} \implies \Delta\theta_n = 50 \text{ K}$$

temperature different from the nominal one

$$c = \frac{\Phi_n}{(\Delta\theta_n)^n}$$

$$\Phi(\Delta\theta_a) = c(\Delta\theta_a)^n = \Phi_n \left(\frac{\Delta\theta_a}{\Delta\theta_n} \right)^n$$

Example of a technical information sheet

example taken from a technical sheet by FONDITAL

TRIBECA

Standard supply	235 - 335 - 350 - 435	from 4 to 20 elements
	500 - 535 - 600	
	685 - 700 - 800 - 835	from 4 to 16 elements
	900 - 935 - 1000 - 1135	from 4 to 9 elements
	1200 - 1400 - 1435	
	1600 - 1735 - 1935	from 4 to 12 elements
Colours	see colours table	
Maximum working pressure	16 bar	
Test pressure	24 bar	
Aleternum treatment	Supplied as standard	

MEASURES EXPRESSED IN MILLIMETRES

Model	Heat output					
	ΔT 20	ΔT 30	ΔT 40	ΔT 50	ΔT 60	ΔT 70
	W/sect.	W/sect.	W/sect.	W/sect.	W/sect.	W/sect.
235	9,6	16,0	23,1	30,6	38,6	46,9
335	12,5	21,1	30,5	40,5	51,1	62,3
350	13,0	21,8	31,5	41,9	52,9	64,4
435	15,2	25,6	37,1	49,4	62,5	76,1
500	16,9	28,5	41,3	55,1	69,7	85,0
535	17,8	30,1	43,6	58,2	73,6	89,8
600	19,5	32,9	47,8	63,8	80,8	98,6
685	21,6	36,6	53,3	71,2	90,2	110,2
700	22,0	37,3	54,2	72,5	91,8	112,2
800	24,5	41,6	60,6	81,1	102,8	125,8
835	25,4	43,1	62,8	84,1	106,7	130,5
900	27,0	45,9	67,0	89,7	113,9	139,3

Model	Heat output					
	ΔT 20	ΔT 30	ΔT 40	ΔT 50	ΔT 60	ΔT 70
	W/sect.	W/sect.	W/sect.	W/sect.	W/sect.	W/sect.
935	27,9	47,5	69,2	92,7	117,7	144,0
1000	29,6	50,3	73,4	98,3	124,9	152,8
1135	33,0	56,2	82,0	110,0	139,8	171,2
1200	34,6	59,9	87,5	115,7	149,3	182,8
1400	39,7	67,9	99,2	133,3	169,6	207,9
1435	40,7	69,5	101,6	136,4	173,5	212,7
1600	45,1	77,1	112,6	151,2	192,3	235,6
1735	48,9	83,4	121,8	163,4	207,8	254,6
1800	50,7	86,4	126,3	169,4	215,4	263,9
1935	54,5	92,9	135,7	181,9	231,3	283,3
2000	56,4	96,1	140,2	188,1	239,0	292,7

After sizing the radiator the required water flow can be computed

$$\Phi(\Delta\theta_a) = \Phi_n \cdot \left(\frac{\Delta\theta}{\Delta\theta_n} \right)^n = \dot{m} \cdot c \cdot \Delta\theta_{mr}$$

con

\dot{m} mass water flow (water or additive water).

c specific heat capacity (4,187 kJ/kgK for water)

$\Delta\theta$ inlet and outlet temperature difference $\Delta\theta_{mr} = \theta_i - \theta_r$.

water mass flow

Once computed the mass flow the piping can be sized using specified velocities which depend on:

- pressur losses
- noise
- corrosion
- air

recommended water velocity

Recommended velocity (m/s) for hot and chilled water networks

	pipes main	pipes secondary	branches to heating bodies
steel pipes	1.5 - 2.5	0.5 - 1.5	0.2 - 0.7
copper pipes	0.9 - 1.2	0.5 - 0.9	0.2 - 0.5
plastic pipes	1.5 - 2.5	0.5 - 1.5	0.2 - 0.7

Types of fluid flow

laminar flow

- regular flow
- low velocities
- low pressure drops or head loss
- reduced heat exchange

turbulent flow

- high velocities
- chaotic motion
- high pressure drops and strong heat exchange

dimensionless groups

Reynolds number

- heat exchanges and pressure drops are computed using correlations
- Re fundamental parameter for calculating flow type
- ratio between inertial forces and viscous forces
- for each geometry determines whether the motion is *laminar* or *turbulent*

$$Re = \frac{\rho \cdot u \cdot L \cdot \cancel{\psi}}{\mu \cdot \cancel{\psi} / L \cdot \cancel{L^2}} = \frac{\rho \cdot u \cdot L}{\mu}$$

u speed

ρ density

μ dynamic viscosity kg/(m s)

- laminar flow $Re < 2000$ in round ducts and pipes.
- transition $2000 \leq Re < 4000$
- turbulent $4000 \leq Re$

Steady Flow Energy Equation

relationship between pressure and velocity in a duct

$$(p_2 - p_1) + \frac{1}{2}\rho \cdot (u_2^2 - u_1^2) + g \cdot \rho \cdot (z_2 - z_1) + \Delta p_l = 0$$

u velocity

p pressure

z elevation

Δp_l pressure loss

Steady Flow Energy Equation

total pressure

$$P_t = p + \frac{1}{2} \cdot \rho \cdot u^2$$
$$P_{t,1} - P_{t,2} = \rho \cdot g \cdot (z_2 - z_1) + \Delta p_l$$

- the pressure difference between inlet and outlet depends on head losses and height difference
- the formula is valid for closed-circuit and open-circuit systems
- for closed-circuit systems the elevation head term disappears
- Δp_l takes into account the losses along the pipe and fittings discontinuities

pressure loss

Friction Factor

$$\frac{\Delta p}{L} = r = F_a \frac{1}{D} \rho \frac{v^2}{2}$$

r [Pa/m] pressure drop per unit length $\frac{\Delta p}{L}$

L length of the duct

D diameter of the duct

ρ density of the fluid

v velocity of the fluid

F_a friction factor

- pressure drops are proportional to the square of the velocity of the fluid
- depend on the flow regime, laminar or turbulent
- can be calculated with diagrams or formulas

Moody diagram

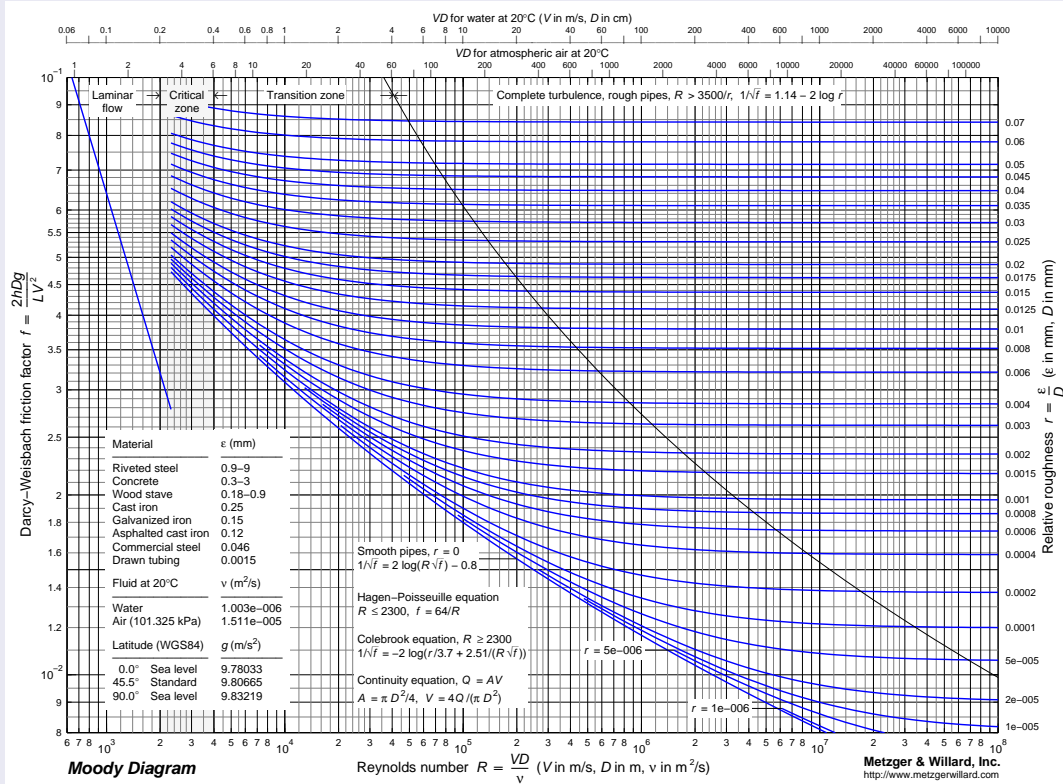

f and Re

- laminar flow f is affected mainly by the viscous force of the fluid flow is a function of Re only.

$$f = \frac{64}{Re}$$

- smooth tube $Re > 4000$ surface roughness submerged in laminar sublayer, f decreases with Re

$$f = \frac{0.316}{Re^{0.25}}$$

- with an increase of Re laminar becomes thinner than roughness. f increases
- if $Re > Rouse\ limit$ f depends on relative roughness ϵ/D only

can be obtained with Colebrook equation:

$$\frac{1}{\sqrt{F_a}} = -2 \cdot \log \left(\frac{k}{3,7 \cdot D} + \frac{2,51}{Re\sqrt{F_a}} \right)$$

where

k absolute roughness

Re Reynolds number

- implicit formulation
- difficult to be used for computing head losses
- other formulas are available in explicit form

Absolute roughness

low roughness

$$0.002 < k < 0.007 \text{ mm}$$

- copper
- plastic water pipe

medium roughness

$$0.02 < k < 0.09 \text{ mm}$$

- steel
- galvanized steel

high roughness

$$0.2 < k < 1.0 \text{ mm}$$

- scaled steel
- corroded steel
- concrete

Alternative formulas

Swamee-Jain

$$F_a = 0.25 \cdot \left[\log \left(\frac{k/D}{3.7} + \frac{5.74}{Re^{0.9}} \right) \right]^{-2}$$

Haaland

$$\frac{1}{F_a} = -1.8 \cdot \log \left[\left(\frac{k/D}{3.7} \right)^{1.11} + \frac{6.9}{Re} \right]$$

Atsui-saal

$$f^* = 0.11 \cdot \left(\frac{k}{D} + \frac{68}{Re} \right)^{0.25}$$

$$f^* > 0.018 \quad F_a = f^*$$

$$f^* < 0,018 \quad F_a = 0,85 \cdot f^* + 0,0028$$

simplified formulas

Quaderni Caleffi

practical formulas for F_a with different tube material

low roughness $2\mu m < k < 7\mu m$ (Cu, PE)

$$F_a = 0,316 Re^{-0,25}$$

medium roughness $20\mu m < k < 90\mu m$ (acciaio)

$$F_a = 0,07 Re^{-0,13} D^{-0,14}$$

high roughness $0,2mm < k < 1mm$ Colebrook equation or alternatives

Friction chart

from ASHRAE

steel pipes

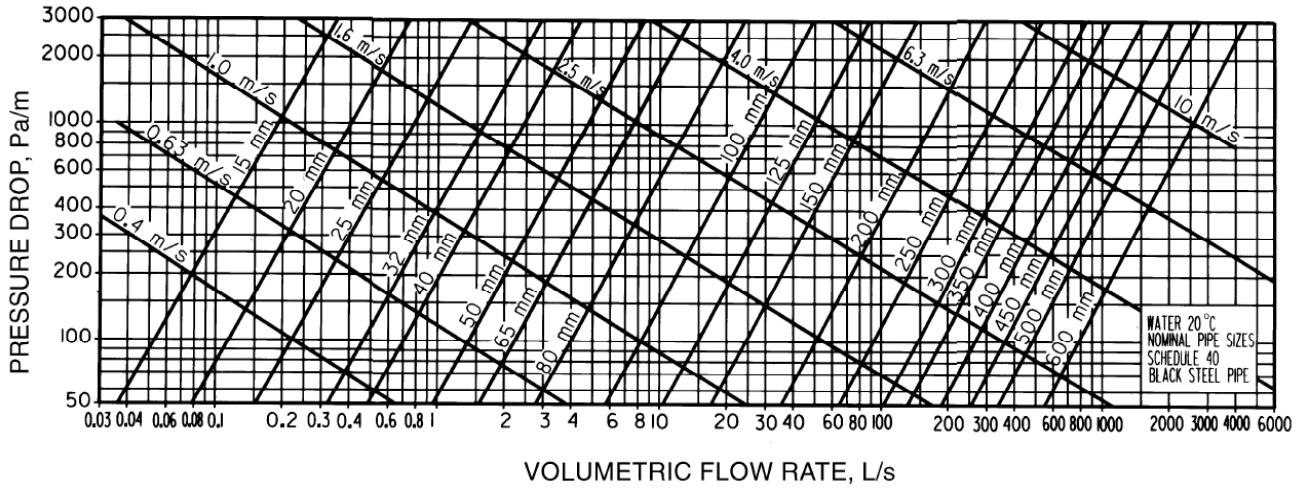

Friction chart

from ASHRAE

copper pipes

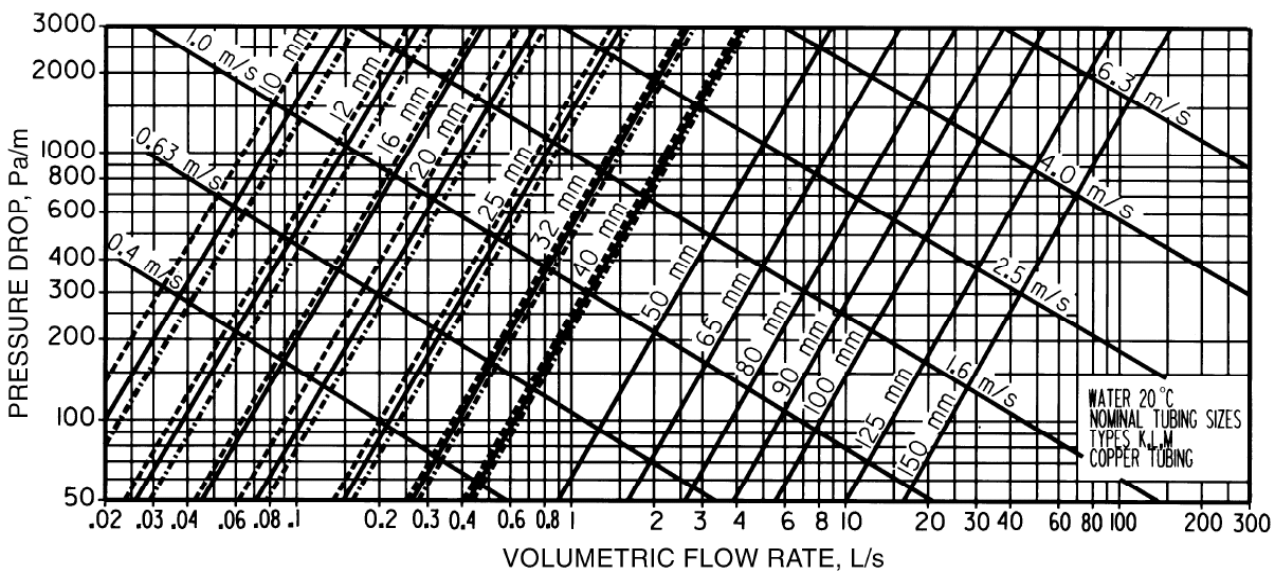

- circuits with bends fittings valves
- resistance coefficients are introduced

Computing methods

- direct
- equivalent length
- kv factors kv and kv_{001}

direct method

pressure loss in fittings

$$z = \xi \cdot \rho \cdot \frac{u^2}{2}$$

ξ loss coefficient

total pressure loss

$$\Delta z = L \cdot r + \left(\sum \xi \right) \cdot \rho \cdot \frac{u^2}{2}$$

typical pressure loss coefficients

quaderni caleffi

Diametro interno tubi rame, PEad, PEX		8-16 mm	18-28 mm	30-54 mm	>54 mm
Diametro esterno tubi acciaio		3/8"-1/2"	3/4"-1"	1 1/4"-2"	>2"
Tipo di resistenza localizzata	Simbolo				
Curva stretta a 90° $r/d = 1.5$		2.0	1.5	1.0	0.8
Curva normale a 90° $r/d = 2.5$		1.5	1.0	0.5	0.4
Curva larga a 90° $r/d > 3.5$		1.0	0.5	0.3	0.3
Curva stretta a U $r/d = 1.5$		2.5	2.0	1.5	1.0
Curva normale a U $r/d = 2.5$		2.0	1.5	0.8	0.5
Curva larga a U $r/d > 3.5$		1.5	0.8	0.4	0.4
Allargamento		1.0			
Restringimento		0.5			
Diramazione semplice con T a squadra		1.0			
Confluenza semplice con T a squadra		1.0			
Diramazione doppia con T a squadra		3.0			
Confluenza doppia con T a squadra		3.0			
Diramazione semplice con angolo inclinato (45°-60°)		0.5			
Confluenza semplice con angolo inclinato (45°-60°)		0.5			
Diramazione con curve d'invito		2.0			
Confluenza con curve d'invito		2.0			

Diametro interno tubi rame, PEad, PEX		8-16 mm	18-28 mm	30-54 mm	>54 mm
Diametro esterno tubi acciaio		3/8"-1/2"	3/4"-1"	1 1/4"-2"	>2"
Tipo di resistenza localizzata	Simbolo				
Valvola di intercettazione dritta		10.0	8.0	7.0	6.0
Valvola di intercettazione inclinata		5.0	4.0	3.0	3.0
Saracinesca a passaggio ridotto		1.2	1.0	0.8	0.6
Saracinesca a passaggio totale		0.2	0.2	0.1	0.1
Valvola a sfera a passaggio ridotto		1.6	1.0	0.8	0.6
Valvola a sfera a passaggio totale		0.2	0.2	0.1	0.1
Valvola a farfalla		3.5	2.0	1.5	1.0
Valvola a ritegno		3.0	2.0	1.0	1.0
Valvola per corpo scaldante tipo dritto		8.5	7.0	6.0	—
Valvola per corpo scaldante tipo a squadra		4.0	4.0	3.0	—
Detentore dritto		1.5	1.5	1.0	—
Detentore a squadra		1.0	1.0	0.5	—
Valvola a quattro vie		6.0		4.0	
Valvola a tre vie		10.0		8.0	
Passaggio attraverso un radiatore		3.0			
Passaggio attraverso una caldaia		3.0			



equivalent length

virtual length of pipe

$$L_{tot} = L + \sum L_E$$

L_{tot} virtual length of pipe

L real length of pipe

L_E equivalent length

total pressure losses

$$\Delta z = L_{tot} \cdot r$$



direct method

$$\Delta p_c = \xi \cdot \frac{1}{2} \cdot \rho \cdot u^2$$

$$\Delta p_c = r \cdot L_E$$

$$r = \xi \cdot \frac{\rho \cdot u^2}{2 \cdot D}$$

$$L_E = \frac{\xi \cdot D}{F_A}$$

pressure loss in valves

Flow coefficient K_v

$$G = K_v \sqrt{\Delta p} \quad G \text{ [m}^3\text{/h]; } \Delta p \text{ [bar]}$$

for reduced flow rates and pressures $K_{v0,01}$

$$G = K_{v0,01} \sqrt{\Delta p \cdot 100} \quad G \text{ [l/h]; } \Delta p \text{ [bar]}$$

K_v volumetric flow rate in m³/h obtained with $\Delta p = 1$ bar.

$K_{v0,01}$ volumetric flow rate in l/h with $\Delta p = 0,01$ bar.

pressure loss in valves

imperial units

Flow coefficient C_v

$$G = C_v \sqrt{\Delta p} \quad G \text{ [GPM]; } \Delta p \text{ [psi]}$$

C_v volumetric flow rate in gpm obtained with $\Delta p = 1$ psi.

gpm gallon per minute

psi pounds square inch, 1 psi = 6894.8 Pa

pipe layout

There are several ways to connect heating terminals to the generator: for domestic plants, 3 layouts are mainly used:

- **one pipe**
- **two pipes**
- **manifold**, dual distribution manifolds (also called “modul”)

one pipe distribution

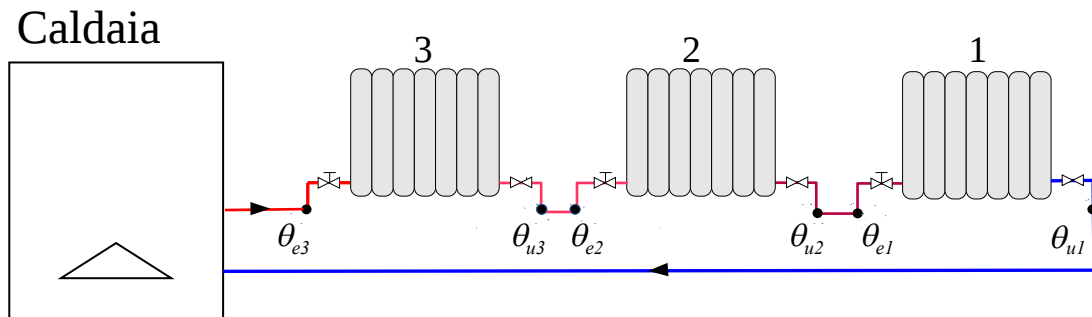

Temperature

$$\Delta\theta_{a3} = (\theta_{e3} + \theta_{u3}) / 2 - \theta_{aria}$$

$$\Delta\theta_{a2} = (\theta_{e2} + \theta_{u2}) / 2 - \theta_{aria}$$

$$\Delta\theta_{a1} = (\theta_{e1} + \theta_{u1}) / 2 - \theta_{aria}$$

$$\Delta\theta_{a3} > \Delta\theta_{a2} > \Delta\theta_{a1}$$

Navigation icons: back, forward, search, etc.

one pipe distribution

Characteristics

- low installation cost
- requires special attention in connecting radiators
- four way valves or bypass
- temperature drop computed on the whole ring
- the temperature of the radiator changes along the ring
- requires high flow rates to minimize the temperature differences

Navigation icons: back, forward, search, etc.

bypass

- il bypass allows the fluid to pass over each radiator
- two flows, one in the radiator and the other in the bypass



four way valve

- allows to regulate the flow inside the radiator.
- again two flows can be identified, one in the radiator and the other in the bypass of the valve.

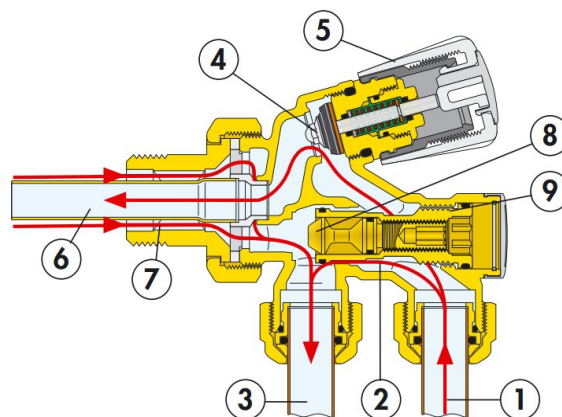

from Caleffi

four way valve

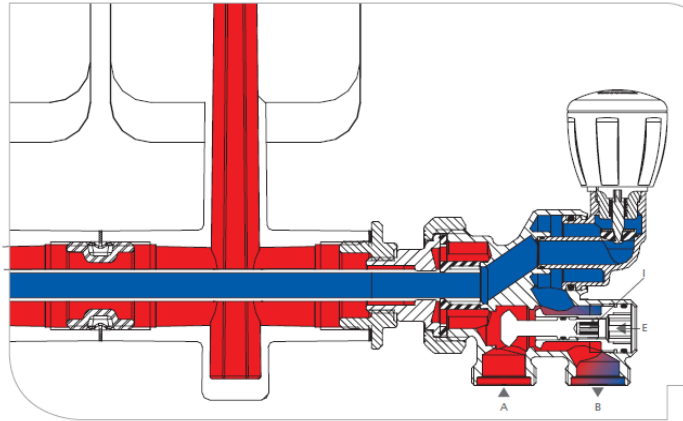

Giacomini

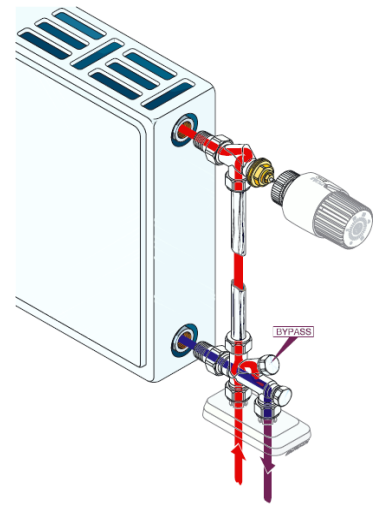

IVAR

pipe sizing

each circuit is analyzed at once:

- 1 heat Φ_A heat exchanged along the whole ring it is the sum of the heat exchanged by each Φ_T heat emitter (radiator or fan coil).

$$\Phi_A = \sum_J \Phi_T$$

- 2 selection of $\Delta\theta_A$, temperature difference, between 10 and 15 K.
- 3 compute **mass flow rate**, G_A :

$$G_A = \frac{\Phi_A}{c \cdot \Delta\theta_A}$$

- 4 with the mass or volumetric flow rate select pipe diameters

once sized the pipes compute **totale loss**:

$$\Delta p_A = r_A \cdot L_A + \sum_i \Delta p_i + \sum_j \xi_j \cdot \rho \cdot \frac{v_A^2}{2}$$

Δp_A total loss of the ring

r_A pressure loss for unit length

L_A pipe length of ring

Δp_i pressure loss for each emitter

ξ_j pressure loss coefficient

v_A fluid velocity

layout with additional circuits

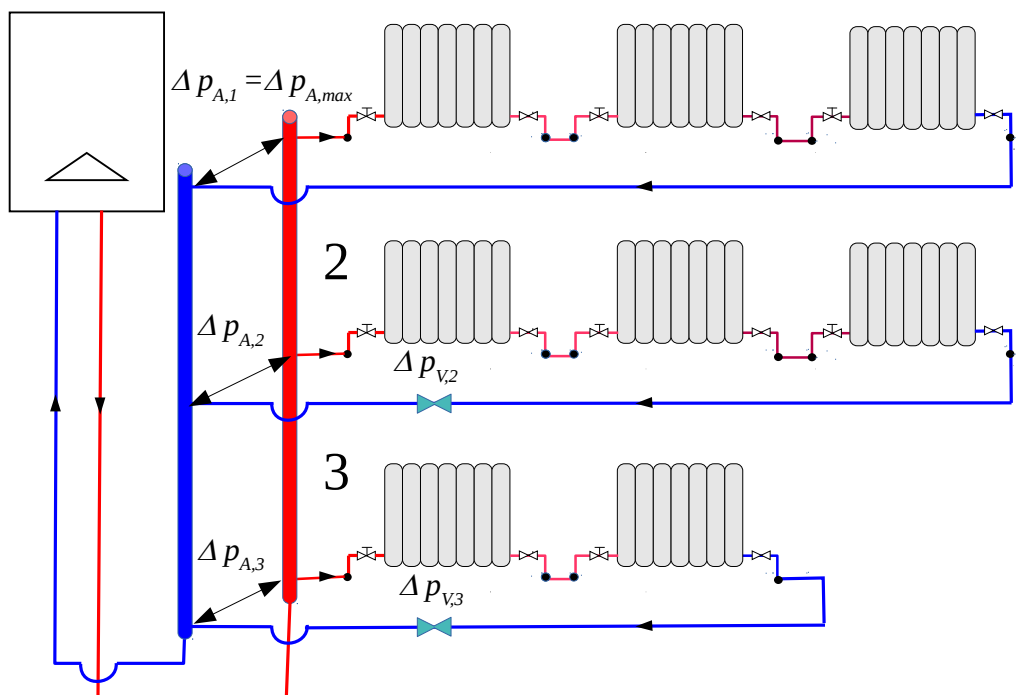

One pipe circuits in parallel

Design pressure distribution

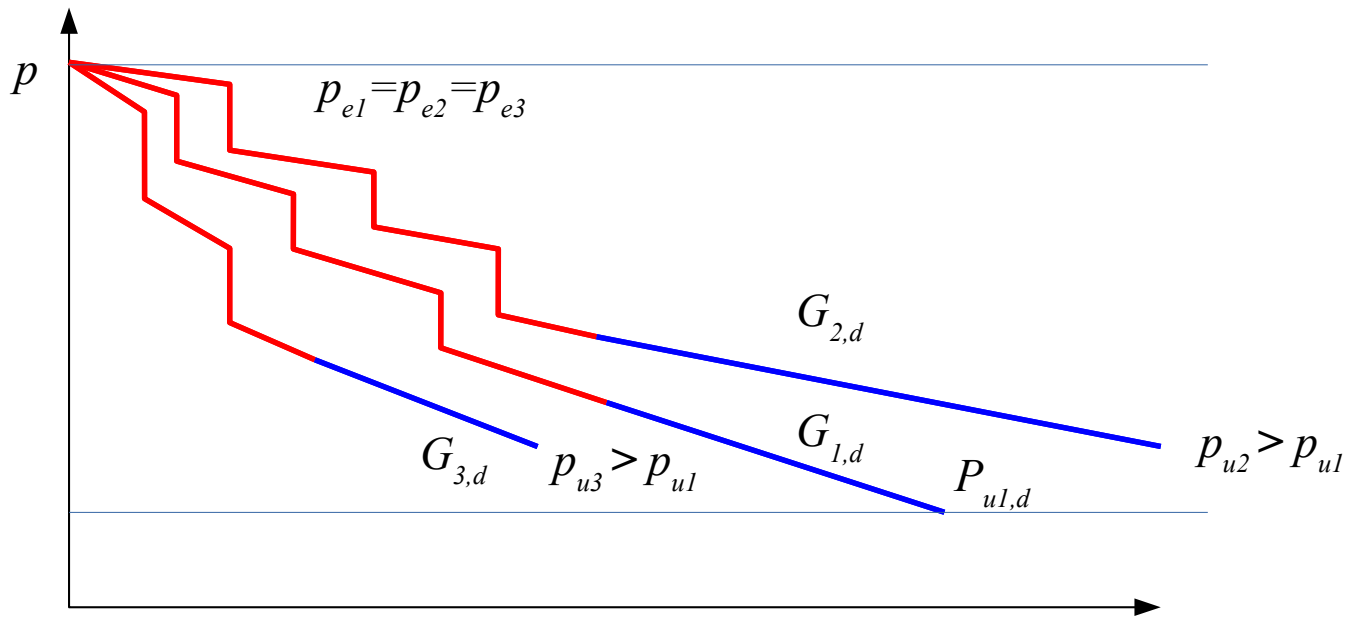

One pipe circuits in parallel

Design pressure distribution

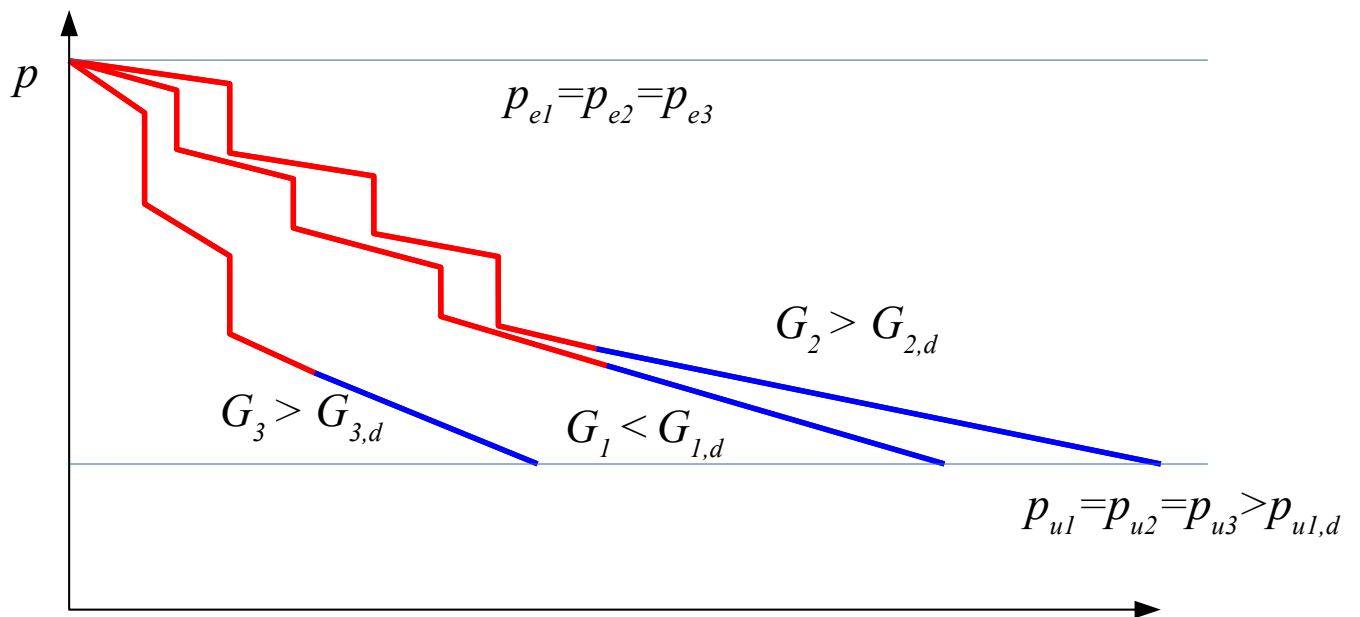

One pipe circuits in parallel

Design pressure distribution, with additional balancing valves

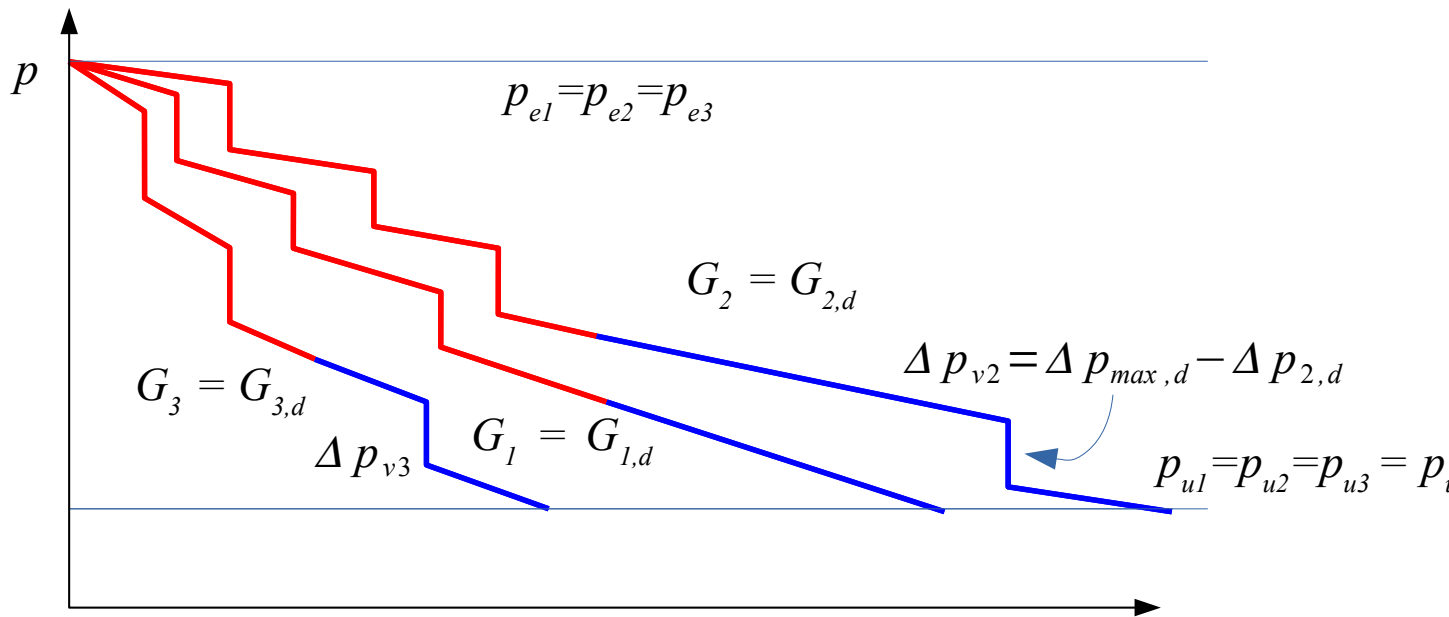

Sizing different rings in parallel

- pressure losses are different for each ring:
- Additional pressure loss ΔP_V for the rings with lower pressure loss

$$\Delta p_{V,i} = \Delta p_{A,max} - \Delta p_{A,i}$$

- compute the k_v or the k_{v001} of the balancing valve

$$K_{V,i} = \frac{G_i}{\sqrt{\Delta P_{V,i}}}$$

- Without valves, the fluid flow is large in the rings with lower pressure loss.

Change of flow rate with different pressures

Simple formula for computing the flow rate with different pressure losses

$$r = \frac{\Delta p}{L} = F_a \frac{1}{D} \rho \frac{u^2}{2}$$

tubi di media scabrezza

$$F_a = 0,07 Re^{-0,13} D^{-0,14} \sim u^{-0,13}$$

$$\Delta p \sim u^{1,87}$$

$$G \sim u \sim \Delta p^{\frac{1}{1,87}}$$

$$G' = G \left(\frac{\Delta p'}{\Delta p} \right)^{\left(\frac{1}{1,87} \right)}$$

considering possible fittings

$$G' = G \left(\frac{\Delta p'}{\Delta p} \right)^{0,525}$$

Two pipe systems

Direct Return

- classical distribution
- used together with other distribution systems
- layout requires balancing of flow rates
- heat emitters near the generator are subjected to higher pressures differences
- balancing valves are required

reverse return

- classical distribution
- used together with other distribution systems
- In a reverse-return system, the piping lengths for each branch circuit, including the main and branch pipes, are almost equal
- pressure difference is almost constant
- higher pipe length, cost and space problems

two pipes direct return

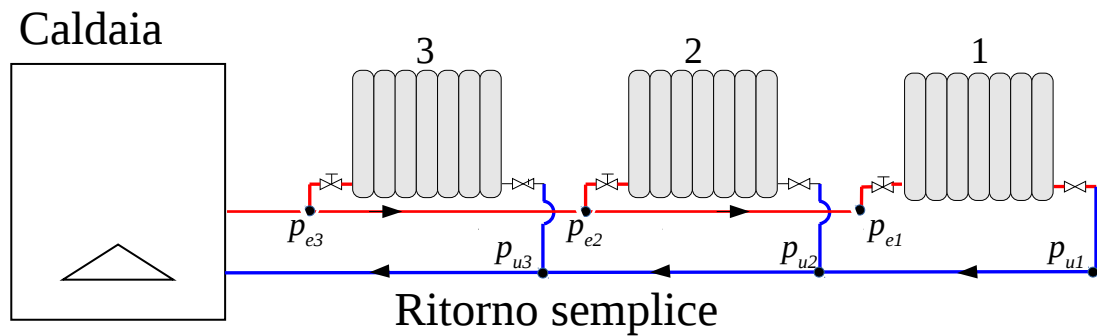

differential pressure

$$p_{e3} > p_{e2} > p_{e1}$$

$$p_{u3} < p_{u2} < p_{u1}$$

$$\Delta p_3 = (p_{e3} - p_{u3}) > \Delta p_2 = (p_{e2} - p_{u2}) > \Delta p_1 = (p_{e1} - p_{u1})$$



two pipes reverse return

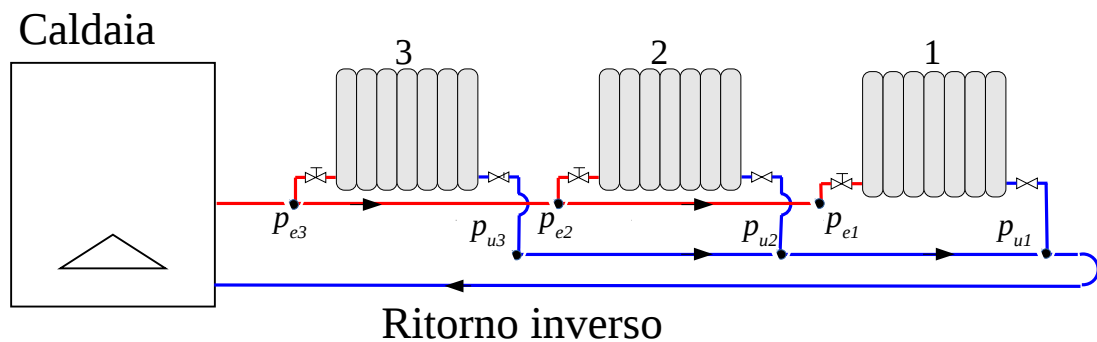

available differential pressure

$$p_{e3} > p_{e2} > p_{e1}$$

$$p_{u3} > p_{u2} > p_{u1}$$

$$\Delta p_3 = (p_{e3} - p_{u3}) \simeq \Delta p_2 = (p_{e2} - p_{u2}) \simeq \Delta p_1 = (p_{e1} - p_{u1})$$



two pipes direct return

sizing and balancing

first terminal

- 1 compute flow rate and pipe diameter
- 2 size the terminal computing design pressure loss $\Delta p_{1,d}$

$$G_1 = \frac{\Phi_1}{c_l \cdot (\theta_{e1} - \theta_{u1})}$$

$$\Delta p_1 = r_1 \cdot L_1 + \sum_j \xi_{1,j} \cdot \frac{1}{2} \cdot \rho \cdot u_1^2$$

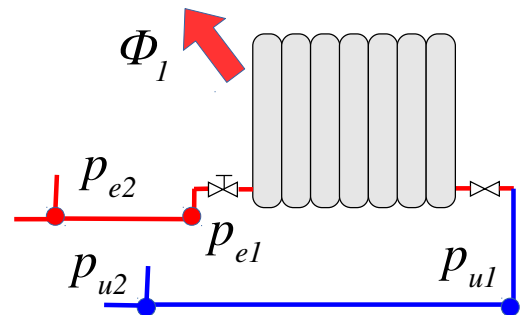

two pipes direct return

sizing and balancing

second terminal

- 1 compute available pressure difference
- 2 size the terminal computing the design pressure loss $\Delta p_{2,d}$
- 3 balance the system using the available pressure difference Δp
- 4 if the new flow rate is too large, add an additional pressure loss $\Delta p_{v,2}$

$$\Delta p_2 = \Delta p_1 + r_{21} \cdot L_{21} + \sum_j \xi_{21,j} \cdot \frac{1}{2} \cdot \rho \cdot u_{21}^2$$

$$G_2 = G_{d,2} \cdot \left(\frac{\Delta p_2}{\Delta p_{d,2}} \right)^{0.525}$$

$$\Delta p_{v,2} = \Delta p_2 - \Delta p_{2,d}$$

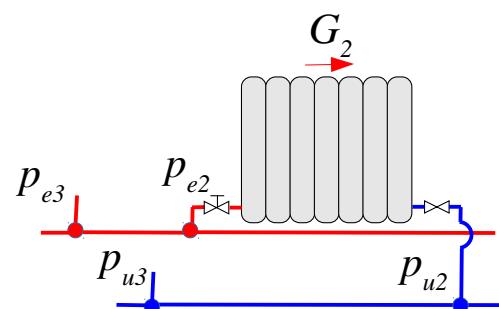
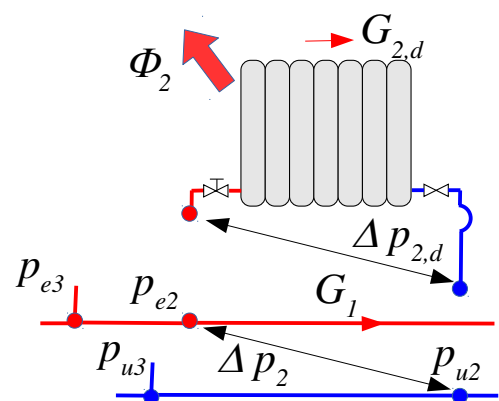

two pipe direct return

sizing and balancing

third terminal

- 1 compute flow rate as the sum of the one of the two previous terminals
- 2 size pipe diameter using the pressure loss Δp_3
- 3 size the terminal and compute the design pressure loss $\Delta p_{3,d}$
- 4 balance the flow rate using the available pressure Δp_3
- 5 add a pressure loss if the flow rate is too large $\Delta p_{v,3}$

$$G_{32} = G_1 + G_2$$

$$\Delta p_3 = \Delta p_2 + r_{32} \cdot L_{32} + \sum_j \xi_{32,j} \cdot \frac{1}{2} \cdot \rho \cdot u_{32}^2$$

$$G_3 = G_{d,3} \cdot \left(\frac{\Delta p_2}{\Delta p_{3,2}} \right)^{0.525}$$

$$\Delta p_{v,3} = \Delta p_3 - \Delta p_{3,d}$$

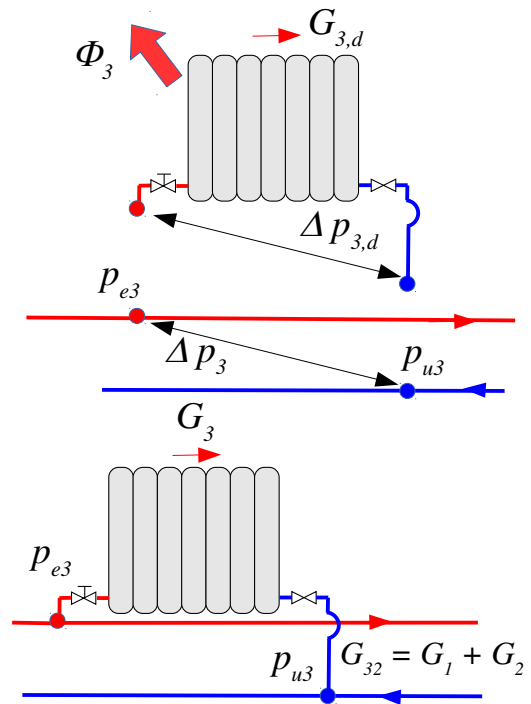

two pipes direct and reverse return

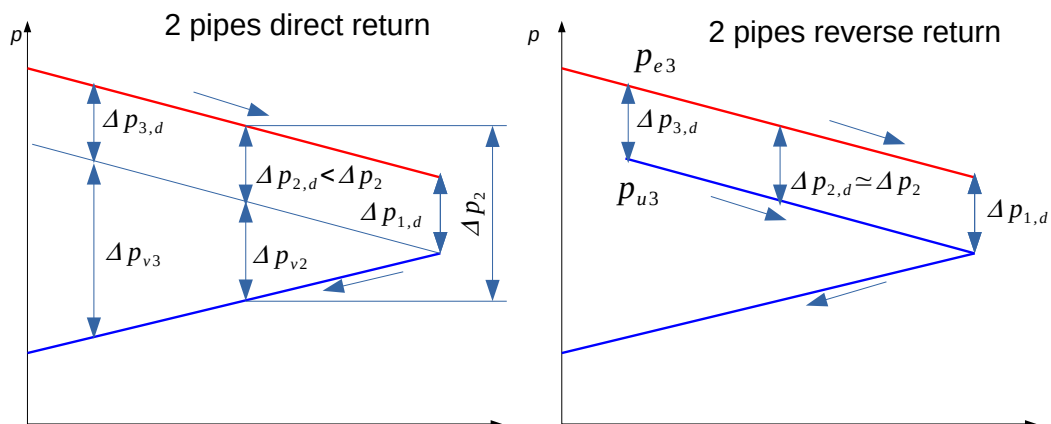

Caratteristiche

- used in new installations
- terminals connected in parallel
- sizing similar to the two pipes system
- requires balancing for correct function

co-planar manifold

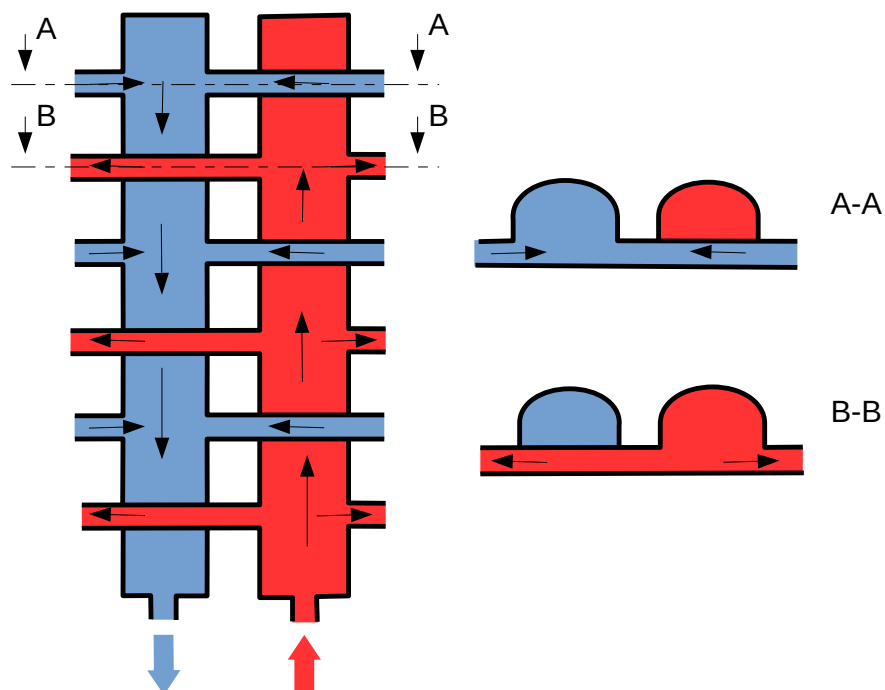

co-planar manifold

Plant system

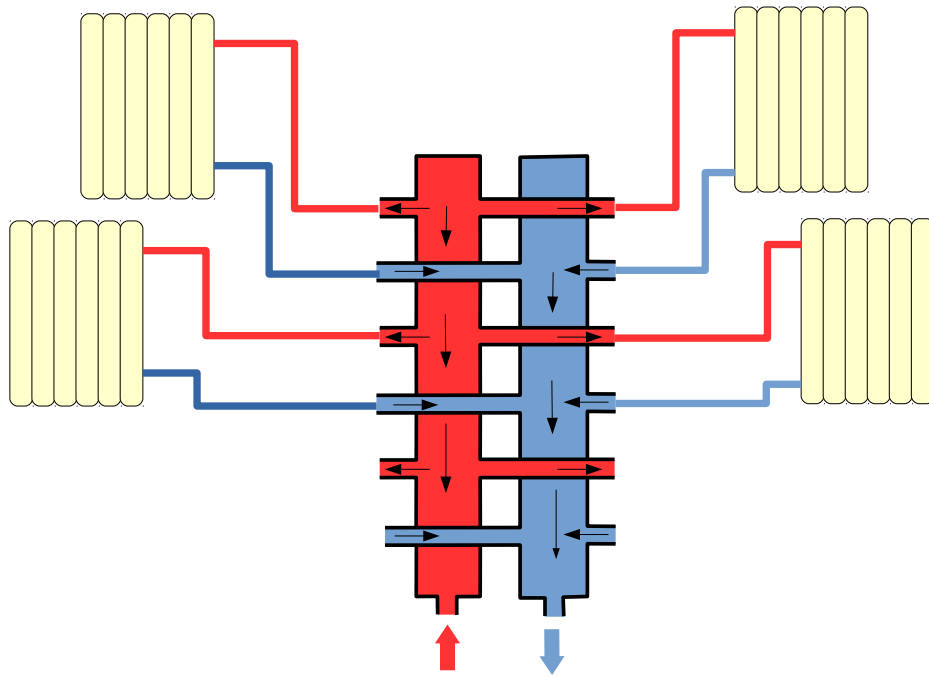

Co-planar manifold

example

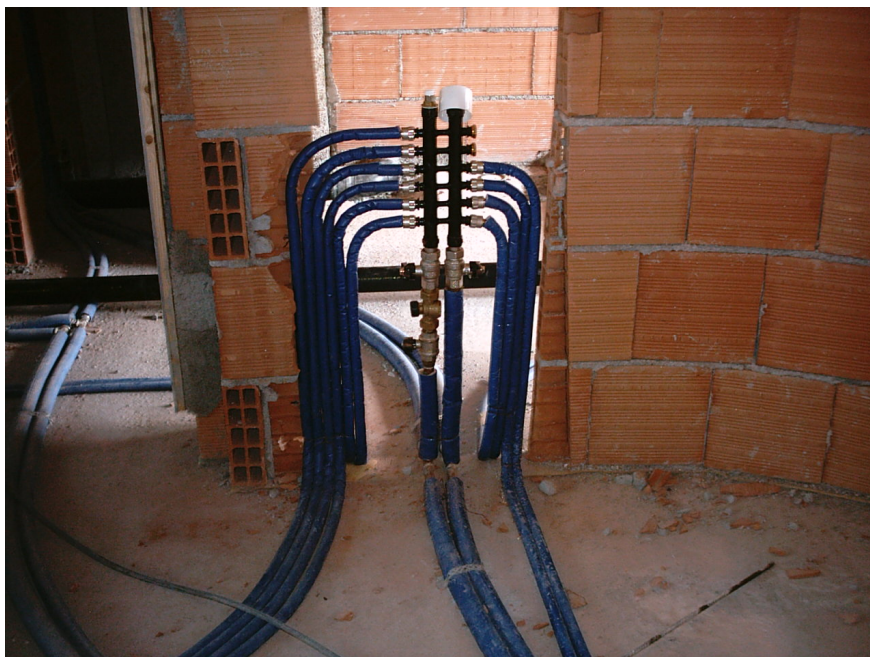

co-planar manifold

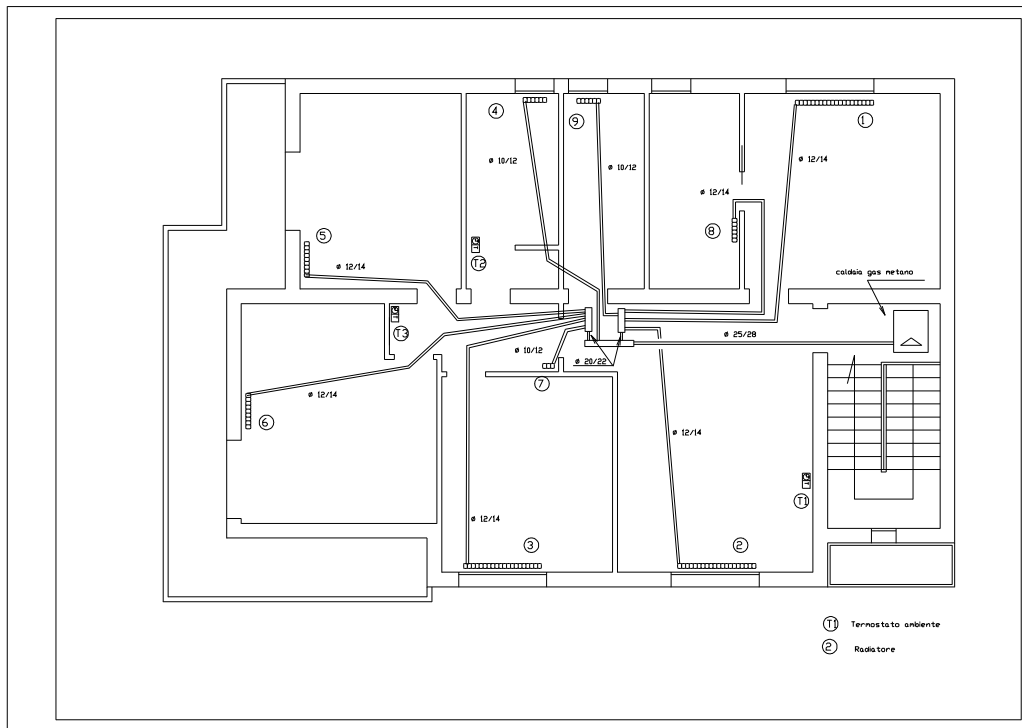

co-planar manifold

Sizing

fixed pipe diameter

- Pipe diameter is fixed
- each terminal must be balanced
- different flow rates and different temperature differences
- size the terminals using the mean temperature difference

sizing with predefined diameter and temperature difference

- set pipe diameter
- balance each terminal
- compute the additional pressure loss
- the pressure loss can be obtained with a different pipe diameter

Radiator valves and lockshields

- Radiators are equipped with valves and lockshield
- lockshield can be used to balance water rings
- radiator valves can be either manual or with thermostatic control heads

manual control

- the position of an obturator sets the pressure loss
- they are used to open or close a circuit, it is not possible to control the temperature

thermostatic control

- the opening of the obturator is controlled by a thermostatic head
- when the room temperature approaches the set value the obturator closes
- this can lead to unbalanced plants



Thermostatic valve head

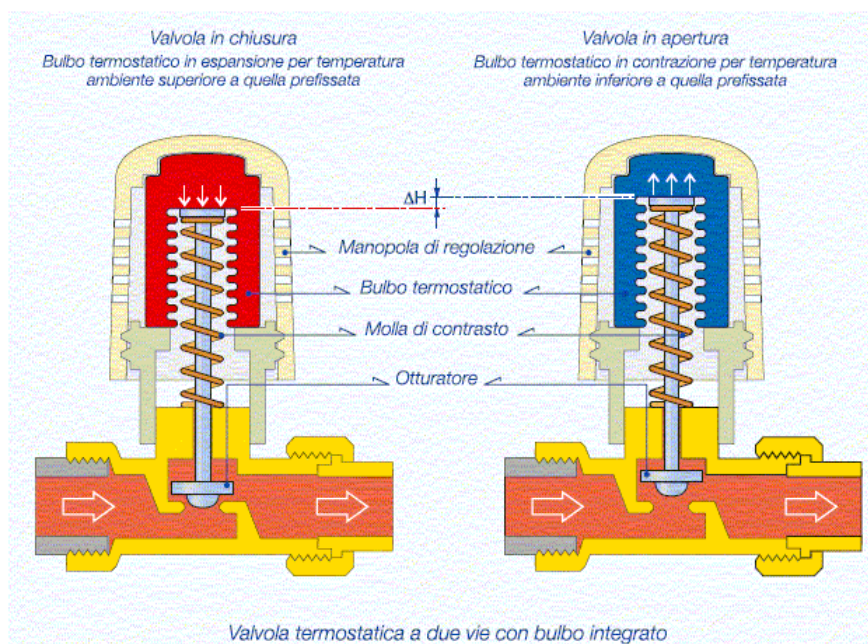

Operating principle

The convertible radiator valves are equipped with an internal device (1) for pre-setting the head loss hydraulic characteristics. Specific passage cross sections (3) can be selected by means of the control nut (2), in order to generate the required resistance to the motion of the medium.

Each passage cross section determines a specific Kv value for the creation of the head loss, which corresponds to a setting position on a graduated scale (4).

Depending on the position in the system, the valve can be pre-set so as to obtain an immediate balancing of the hydraulic circuit, valid for both manual and thermostatic operation.

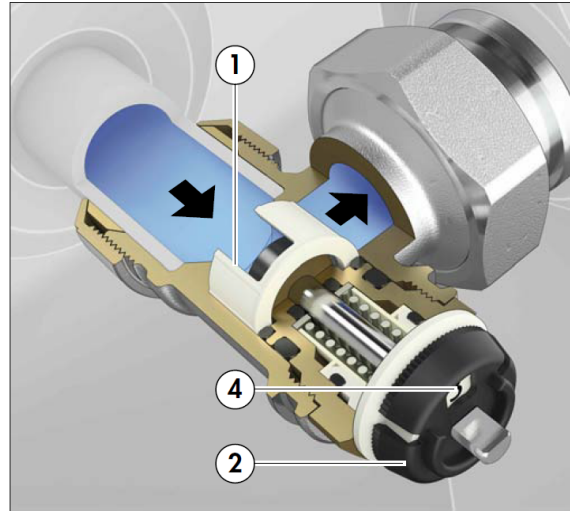
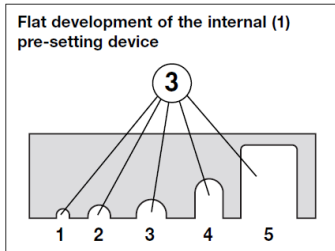

fonte Caleffi

Characteristic pressure loss diagram

Manual control

Valvole termostattabili preregolabili con manopola manuale

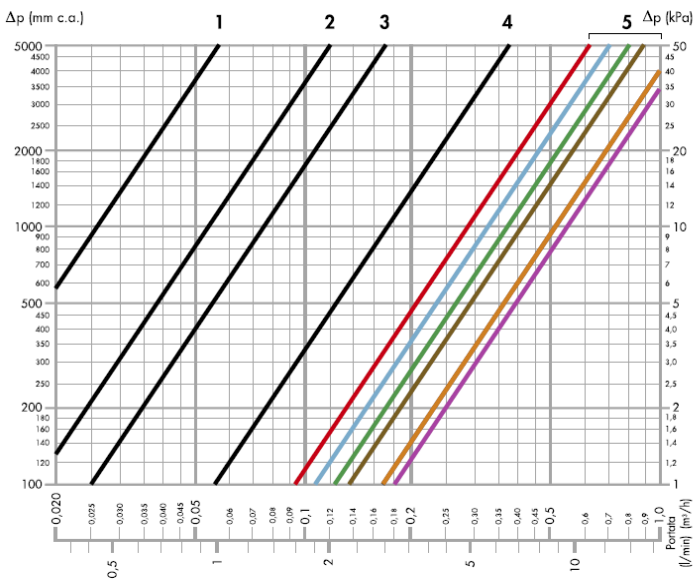

Posizione di prerogolazione	Kvs (m³/h)					
	3/8" squadria	3/8" dritta	1/2" squadria	1/2" dritta	3/4" squadria	3/4" dritta
1	0,08	0,08	0,08	0,09	0,12	0,12
2	0,17	0,17	0,17	0,19	0,22	0,22
3	0,25	0,25	0,25	0,27	0,41	0,41
4	0,55	0,55	0,55	0,56	0,95	0,93
5	1,30	0,90	1,40	1,00	1,80	1,70

fonte Caleffi

Characteristic pressure loss diagram

Thermostatic control

Valvole termostattabili preregolabili con comando termostatico banda proporzionale 2K

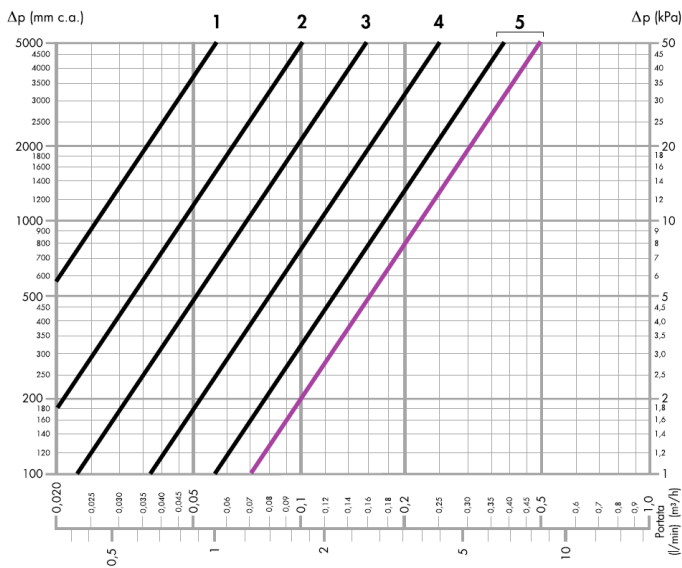

Posizione di prerogolazione	Kv (m³/h) [Banda proporzionale 2K]**					
	3/8" squadra	3/8" dritta	1/2" squadra	1/2" dritta	3/4" squadra	3/4" dritta
1	0,08	0,08	0,09	0,09	0,12	0,12
2	0,15	0,15	0,16	0,16	0,20	0,20
3	0,22	0,22	0,23	0,23	0,32	0,32
4	0,35	0,35	0,36	0,36	0,50	0,50
5	0,50	0,50	0,55	0,55	0,72	0,72

fonte Caleffi



Sizing with predefined pipe diameter and temperature difference

procedure

- 1 for each circuit compute the flow rate
- 2 define pipe diameter and fluid velocity u_j
- 3 compute pressure losses, do not consider the pressure loss of valves
- 4 with preset valves, add the pressure loss with full open valve
- 5 for each circuit determine the required pressure loss
- 6 find the set position of the valve



Sizing with predefined pipe diameter and temperature difference

procedure

- 1 $G_j = \frac{\Phi_j}{c_w \cdot \Delta\theta\rho}$ design flow
- 2 $u_j = \frac{G_j \cdot 4}{d_j^2 \cdot \pi}$ fluid velocity
- 3 $\Delta p_{c,j} = r_j \cdot L_j + \sum_k \frac{1}{2} \cdot \rho \cdot u_j^2$ circuit pressure loss
- 4 $\Delta p_{tot,max} = \Delta p_{c,max} + \Delta p_V$ maximum pressure loss
- 5 $\Delta p_{V,j} = \Delta p_{tot,max} - \Delta p_{c,j}$ pressure loss for each valve
- 6 $k_{V,j} = \frac{G_j}{\sqrt{\Delta p_{V,j}}}$ using a diagram $\Delta p_{V,j}$

Vertical distribution plants

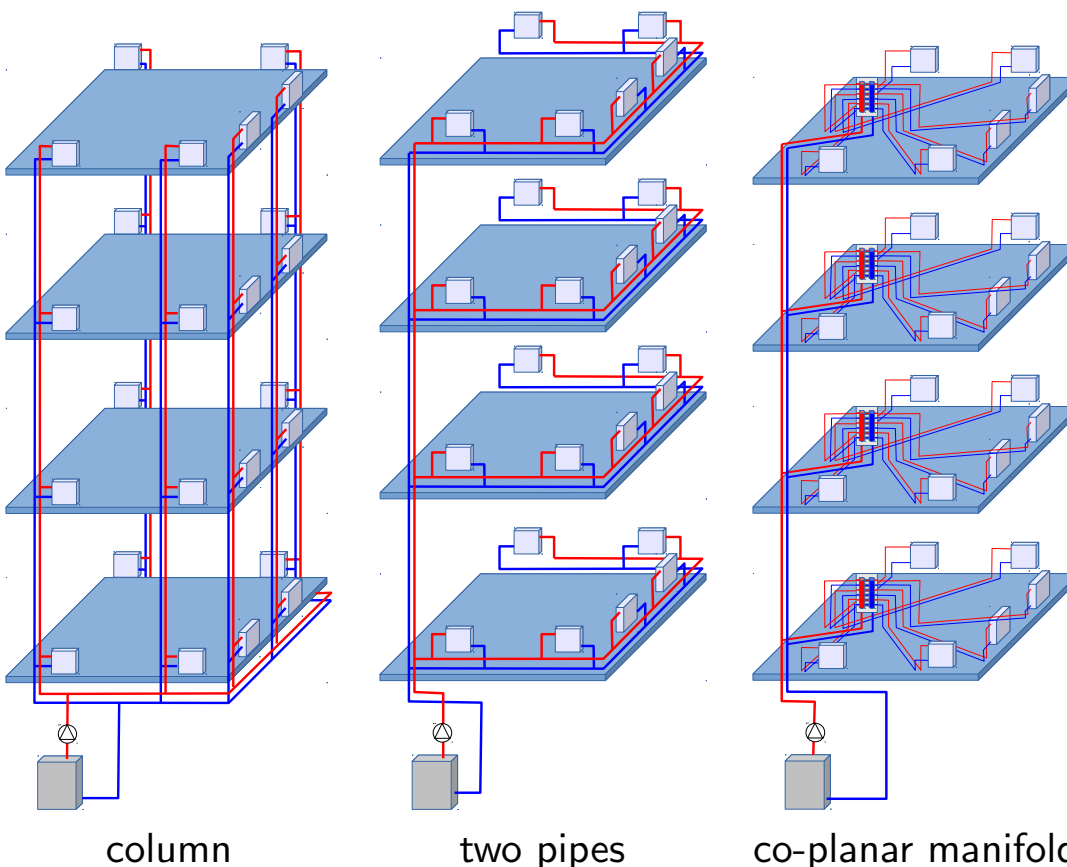

Inlet temperature for heating $30 \div 45^{\circ}\text{C}$, Can be used for cooling during summer season Can be installed in:

- floor** for heating and cooling, the preferred solution in domestic homes.
- wall** heating and cooling, furniture problems
- ceiling** ideal solution for cooling
- standards** the system is described in standards of the series UNI EN 1264

heated floor

- pipes embedded in concrete slab.
- pipes in plastic material must be fixed during installation
 - metal net with clips
 - on preformed insulation material

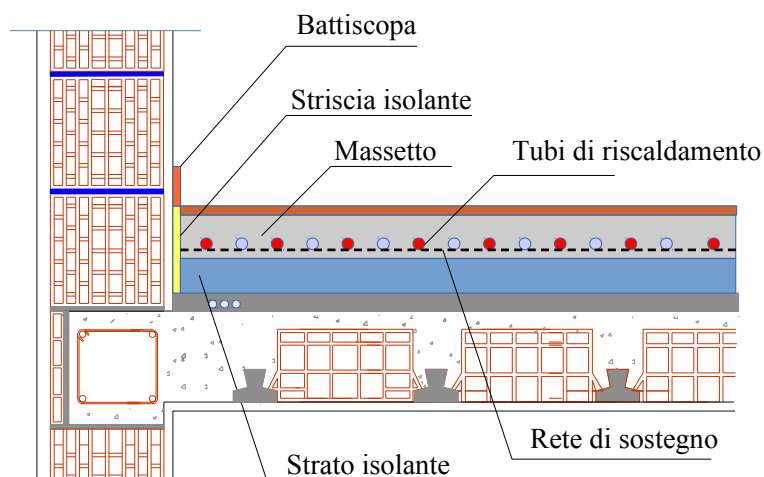

Heated floors

examples



heated floors

Manifold



temperature difference between the heating medium and room temperature

the mean logarithmic temperature difference is expressed as:

$$\Delta\theta_H = \frac{\theta_V - \theta_R}{\ln\left(\frac{\theta_V - \theta_i}{\theta_R - \theta_i}\right)}$$

con

θ_V inlet water temperature

θ_R outlet water temperature

explanation of the terms

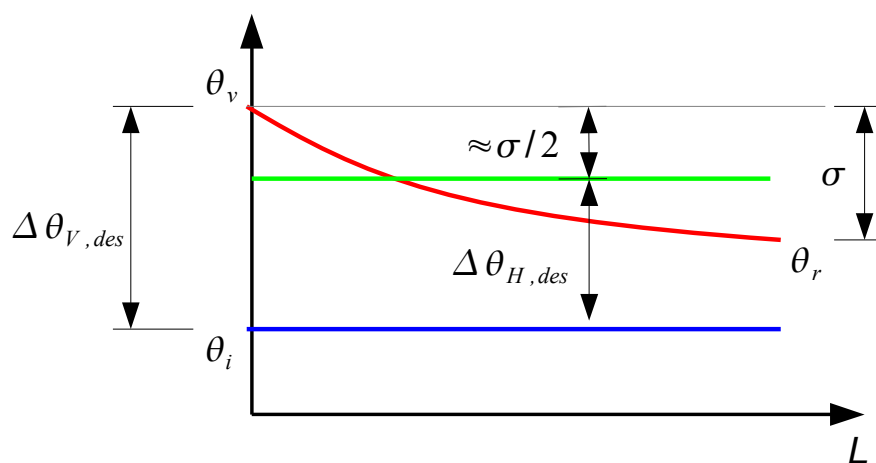

Parameters driving the heat output

- II **Pipe spacing**, T ;
- Lo **screed thickness**, S_V , measured from the plane of pipes
- La **screed conductivity**, λ_E ;
- La **heat resistance of floor covering**, $R_{\lambda B}$;
- II **pipe external diameter**, D , including sheathing for O_2 migration:
- **additional conductive elements**, K_{WL} ;
- II **contact resistance between screed and pipe**.

specific thermal output diagram

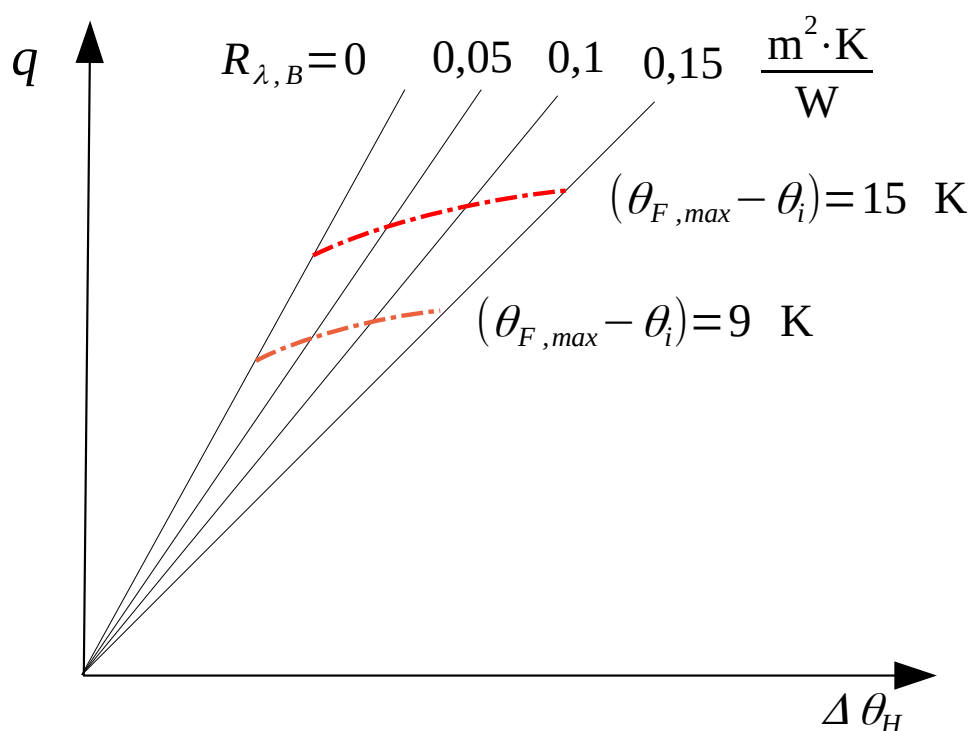

Limits of specific thermal output

- standard prescribes the **maximum floor temperature** 29°C ,
- typically the maximum permissible specific thermal output is about 100 W/m^2 .
- in peripheral areas the maximum temperature could reach 35°C
- the maximum permissible specific thermal output is 175 W/m^2
- usually specific thermal output reaches $80 - 90\text{ W/m}^2$.

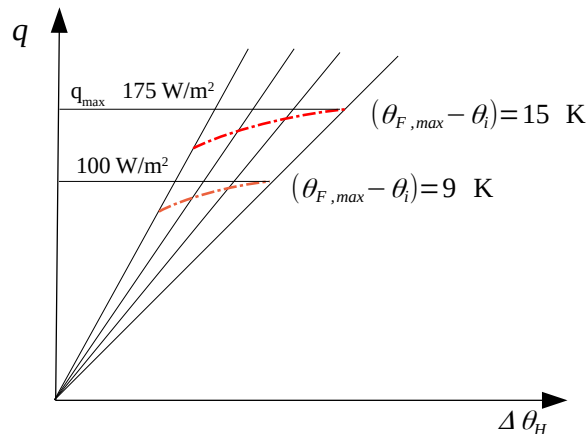

Example of design thermal output from Buderus

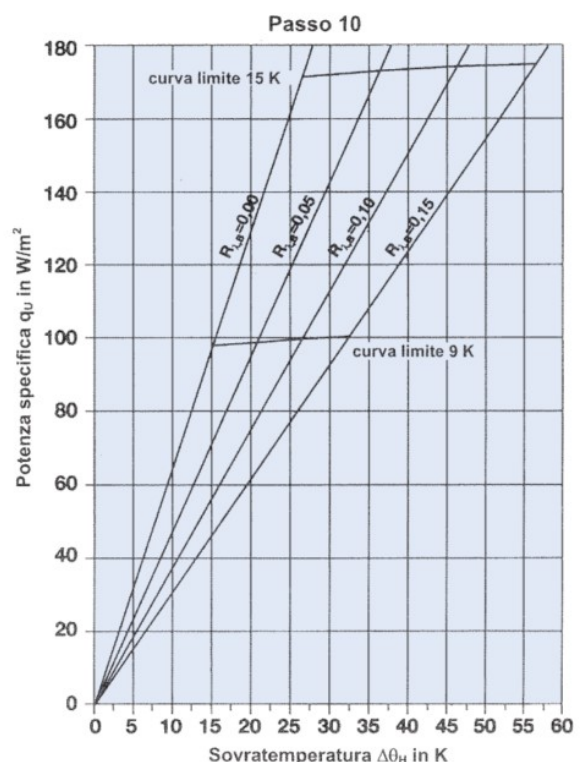
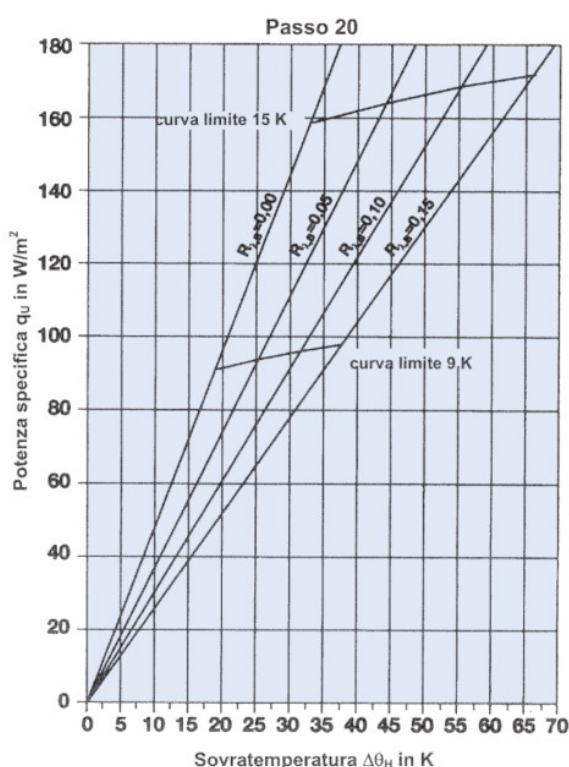

Example of design thermal output

from Buderus

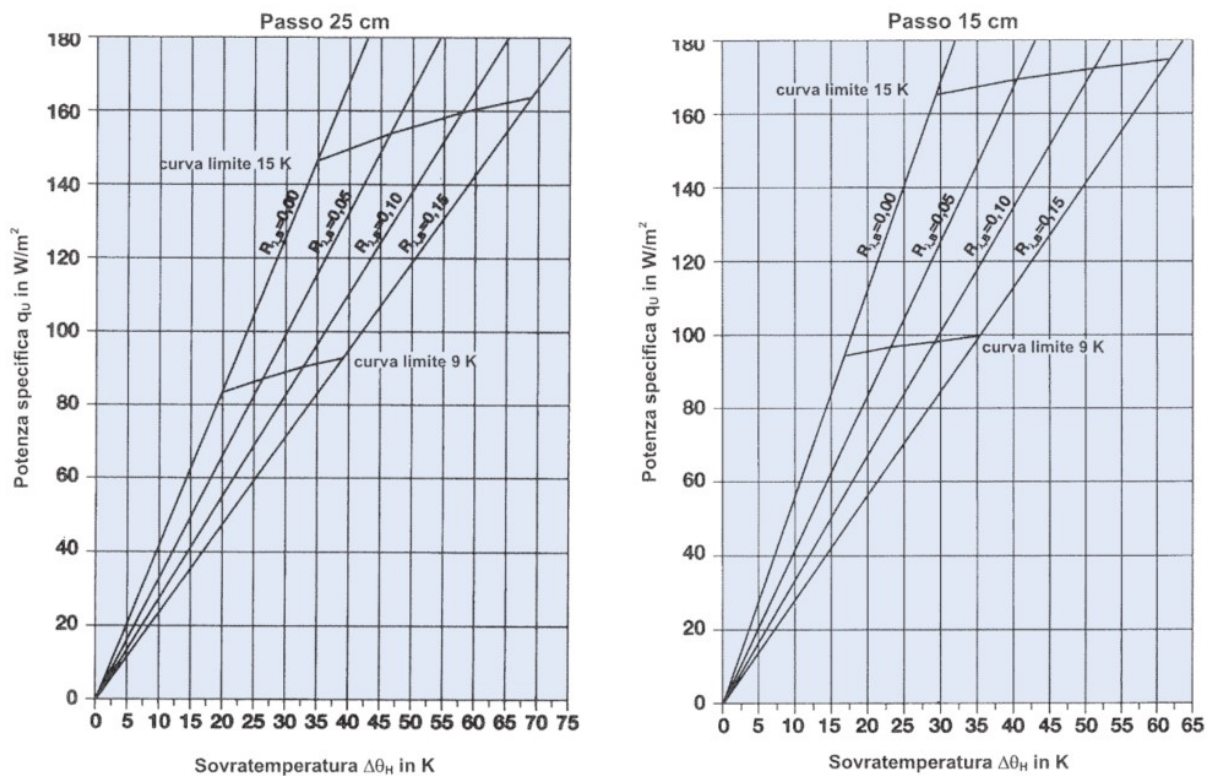

Sizing

for each environment the specific thermal output is computed as:

$$q = \frac{\Phi_{Nf}}{A_f}$$

Φ_{Nf} heat output required for each environment

A_f surface of environment

with peripheral area

$$A_F = A_{F, \text{perim}} + A_{F, \text{calp}} + A_{F, \text{calp}}$$

$$q = \frac{A_{F, \text{perim}}}{A_F} q_{\text{perim}} + \frac{A_{F, \text{calp}}}{A_F} q_{\text{calp}}$$

design temperature difference

$$\Delta\theta_H = \frac{\theta_V - \theta_R}{\ln\left(\frac{\theta_V - \theta_i}{\theta_R - \theta_i}\right)}$$

design temperature difference

$$\sigma = \theta_V - \theta_R$$

design input temperature: $\theta_{V,des}$

input temperature difference

$$\Delta\theta_{V,des} = \theta_{V,des} - \theta_i$$

determination of design flow temperature

$$\sigma / \Delta\theta_H < 0,5$$

$$\sigma = 5 \text{ K} \implies \Delta\theta_H > 10 \text{ K}$$

$$\Delta\theta_{V,des} \leq \Delta\theta_{H,des} + \frac{\sigma}{2}$$

$$\sigma / \Delta\theta_H \geq 0,5$$

$$\sigma = 5 \text{ K} \implies \Delta\theta_H \leq 10 \text{ K}$$

$$\Delta\theta_{V,des} \leq \Delta\theta_{H,des} + \frac{\sigma}{2} + \frac{\sigma^2}{12\Delta\theta_{H,des}}$$

Determination of design temperature difference

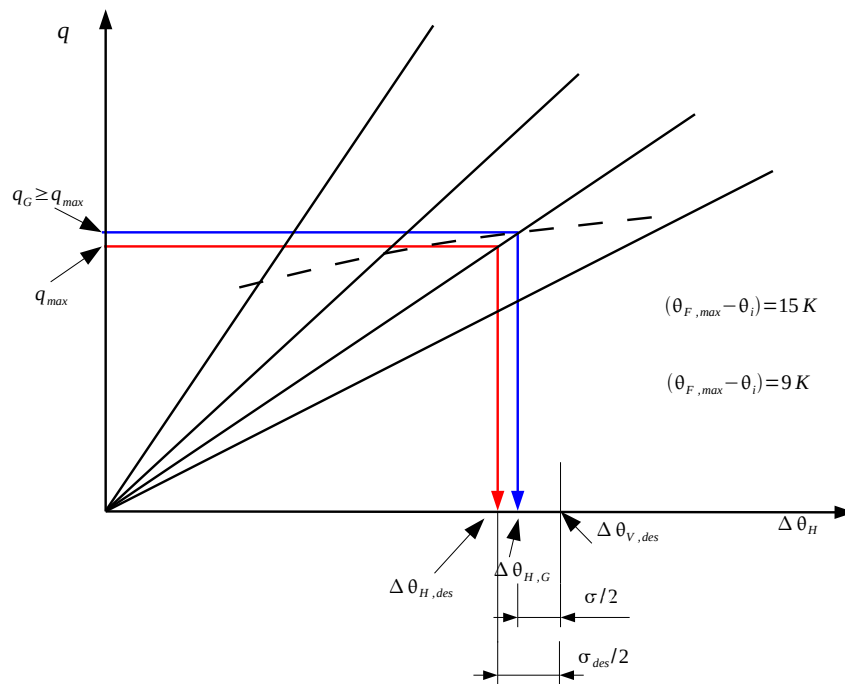

Explanation of terms

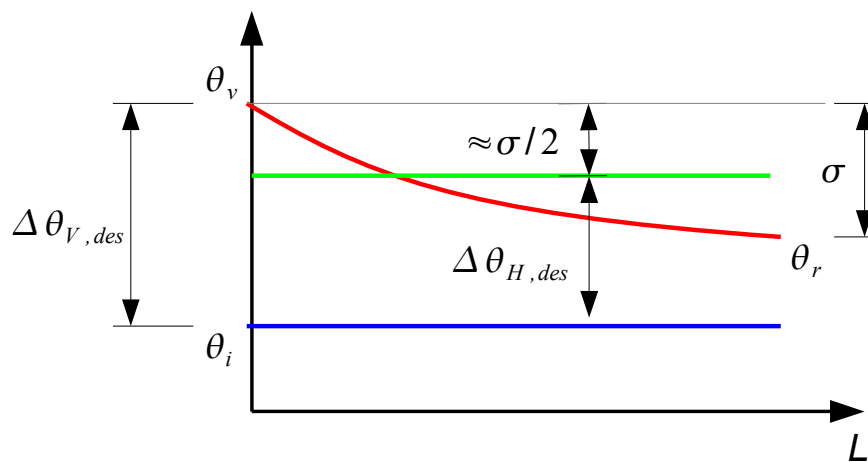

$$\Delta\theta_H = \frac{\theta_V - \theta_R}{\ln\left(\frac{\theta_V - \theta_i}{\theta_R - \theta_i}\right)}$$

$$\Delta\theta_H = \frac{\sigma}{\ln\left(\frac{\Delta\theta_{V,des}}{\Delta\theta_{V,des} - \sigma}\right)}$$

$$\frac{\Delta\theta_{V,des}}{\Delta\theta_{V,des} - \sigma} = e^{\frac{\sigma}{\Delta\theta_H}}$$

$$\Delta\theta_{V,des} = \frac{\sigma}{1 - e^{-\frac{\sigma}{\Delta\theta_H}}}$$

determination of design temperature for other rooms

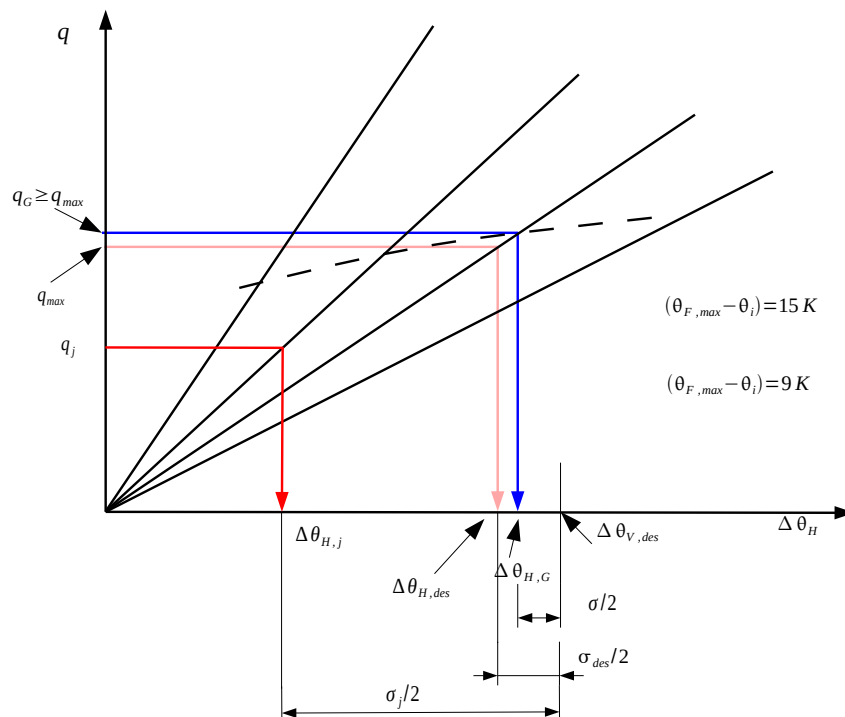

determination of design temperature for other rooms

- inlet temperature is the same
- the temperature difference is different
- in other rooms different pipe spacing can be selected

$$\sigma_j / \Delta_{H,j} < 0,5$$

$$\frac{\sigma_j}{2} = \Delta\theta_{V,des} - \Delta\theta_{H,j}$$

$$\sigma_j / \Delta_{H,j} \geq 0,5$$

$$\sigma_j = 3\Delta\theta_{H,j} \left[\left(1 + \frac{4(\Delta\theta_{V,des} - \Delta\theta_{H,j})}{3\Delta\theta_{H,j}} \right)^{\frac{1}{2}} - 1 \right]$$

explanations of the terms

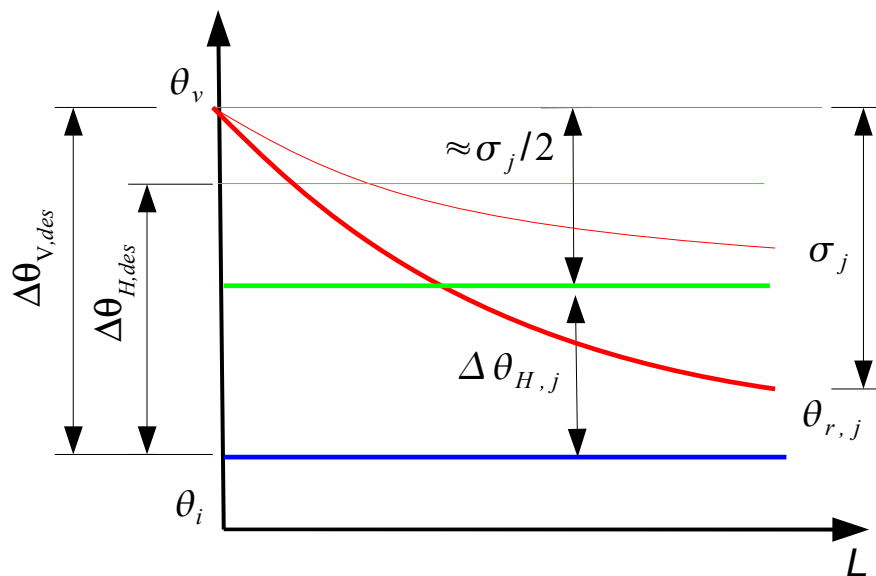

water flow rate determination

for the generic j-th room the heating floor must provide the thermal output $\Phi_{Nf,j}$:

$$\Phi_{Nf,j} = \dot{m}_{H,j} c_w (\theta_V - \theta_R)_j - q_{u,j} \cdot A_F$$

dove:

$\dot{m}_{H,j}$ mass flow for the j-th room

c_w water specific heat capacity

q_u downward specific heat flow rate

A_F floor area

mass flow rate is obtained as

$$\dot{m}_{H,j} = \frac{A_F q_j}{c_w \sigma} \left(1 + \frac{R_o}{R_u} + \frac{\theta_i - \theta_u}{R_u q_j} \right)$$

Hot boiler room

Devices

Boiler Room $\Phi > 35$ kW

- reduced specifications nella *Raccolta R* collection from ISPESL (now INAIL)
- Devices:
 - Security devices
 - protection devices
 - control devices

expansion tank

kind of expansion tank

- the main purpose is to compensate the change of volume
- they may be :
 - open
 - closed

closed expansion tank

atmospheric with or without diaphragm;

pressurized with or without diaphragm;

expansion tank

expansion volume

$$E = \frac{V_A \cdot n}{100}$$

V_A water content

$$n = 0,31 + 3,9 \times 10^{-4} \cdot t_m^2$$

t_m maximum temperature in °C

expansion tank

without diaphragm

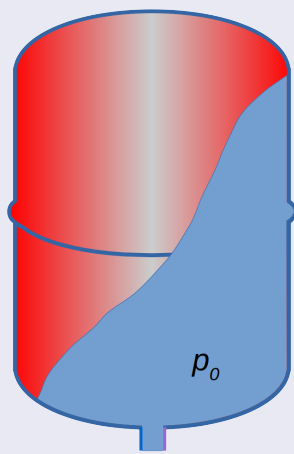

a)

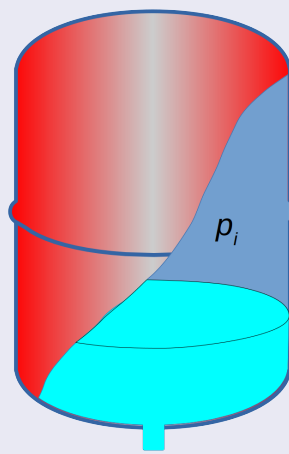

b)

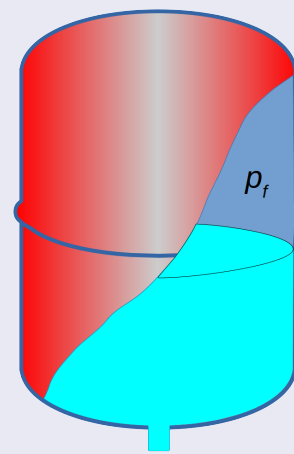

c)

expansion tank

with diaphragm

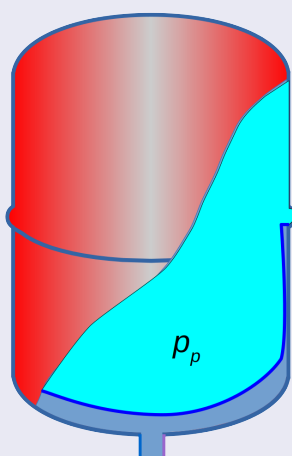

a)

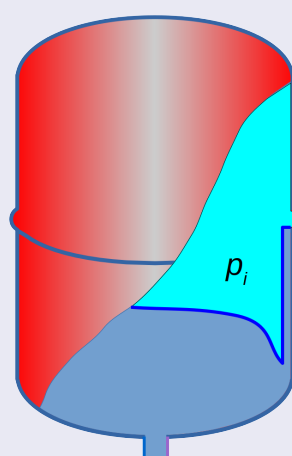

b)

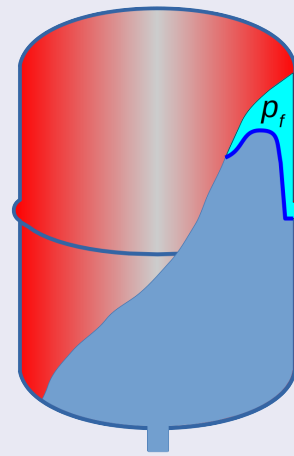

c)

Sizing an expansion tank

without diaphragm

$$V_v = \frac{E}{\frac{p_o}{p_i} - \frac{p_o}{p_f}}$$

E expansion volume

p_o atmospheric pressure

p_i initial atmospheric pressure

p_f set pressure of pressure relief valve

sizing expansion tanks

without diaphragm or bladder

$$p_0 \cdot V_0 = p_i \cdot V_i = p_f \cdot V_f$$

$$E = V_i - V_f$$

$$V_i = V_0 \cdot \frac{p_0}{p_i}$$

$$V_f = V_0 \cdot \frac{p_0}{p_f}$$

$$E = V_0 \cdot \left(\frac{p_0}{p_i} - \frac{p_0}{p_f} \right)$$

$$V_v = V_0 = \frac{E}{\frac{p_0}{p_i} - \frac{p_0}{p_f}}$$

sizing expansion tanks

with diaphragm or bladder

$$V_v = \frac{E}{1 - \frac{p_p}{p_f}} \quad (1)$$

E expansion volume

p_p initial pressure, equal to the hydrostatic pressure plus a value to avoid pressure drops ($p_0 = p_{st} + 0.3 \text{ bar}$)

p_f set pressure of pressure relief valve $p_f = p_{vs} - 0.5 \text{ bar}$

sizing expansion tanks

with diaphragm or bladder

$$p_p \cdot V_v = p_f \cdot V_f$$

$$E = V_v - V_f$$

$$V_f = V_v \cdot \frac{p_p}{p_f}$$

$$E = V_v \cdot \left(1 - \frac{p_p}{p_f}\right)$$

$$V_v = \frac{E}{1 - \frac{p_p}{p_f}}$$

pressure relief valve

How it works

- divert flow as the inlet pressure reaches the valve set pressure
- the nozzle discharge water vapour
- latent heat balance the boiler heat input

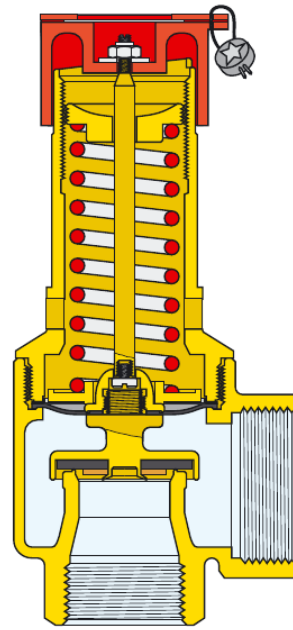

from Caleffi

pressure relief valve

some physics

$$\dot{m}_v \cdot r = \Phi_u$$

$$\Phi_u = \dot{m}_v \cdot r = \frac{\dot{V}}{v_v} \cdot r = \frac{w_{max}}{v_v} \cdot A \cdot r$$

w_{max} nozzle maximum velocity;

v_v water vapour specific volume

A valve area section

$$A = \Phi_u \cdot \frac{v_v}{w_{max} \cdot r}$$

Pressure relief valve

Raccolta R

$$A = 0,005 \cdot \dot{m}_v \cdot \frac{Q}{0,9 \cdot K}$$

Q discharge capacity [kg/h]

A minimum nozzle area square centimeters;

\dot{m}_v water vapour mass flow [kg/h];

F pressure factor, from table;

K Valve efflux coefficient from certification.

discharge pressure values from 0,5 to 12,5 bar

p	0,50	0,60	0,70	0,80	0,90	1,00	1,10	1,20	1,30	1,40	1,50	1,60	1,70
F	2,47	2,32	2,19	2,07	1,97	1,87	1,79	1,71	1,63	1,57	1,51	1,45	1,40
p	1,80	1,90	2,00	2,10	2,20	2,30	2,40	2,50	2,60	2,70	2,80	2,90	3,00
F	1,35	1,31	1,26	1,22	1,19	1,15	1,12	1,09	1,06	1,03	1,01	0,98	0,96
p	3,10	3,20	3,30	3,40	3,50	3,60	3,70	3,80	3,90	4,00	4,20	4,40	4,60
F	0,93	0,91	0,89	0,87	0,85	0,84	0,82	0,80	0,79	0,77	0,74	0,71	0,69
p	4,80	5,00	5,20	5,40	5,60	5,80	6,00	6,20	6,40	6,60	6,80	7,00	7,20
F	0,67	0,65	0,62	0,61	0,59	0,57	0,56	0,54	0,53	0,51	0,50	0,49	0,48
p	7,40	7,60	7,80	8,00	8,20	8,40	8,60	8,80	9,00	9,50	10,0	10,5	11,0
F	0,46	0,45	0,44	0,43	0,43	0,42	0,41	0,40	0,39	0,37	0,36	0,34	0,32
p	11,50	12,00	12,50										
F	0,32	0,30	0,29										

Boiler Room

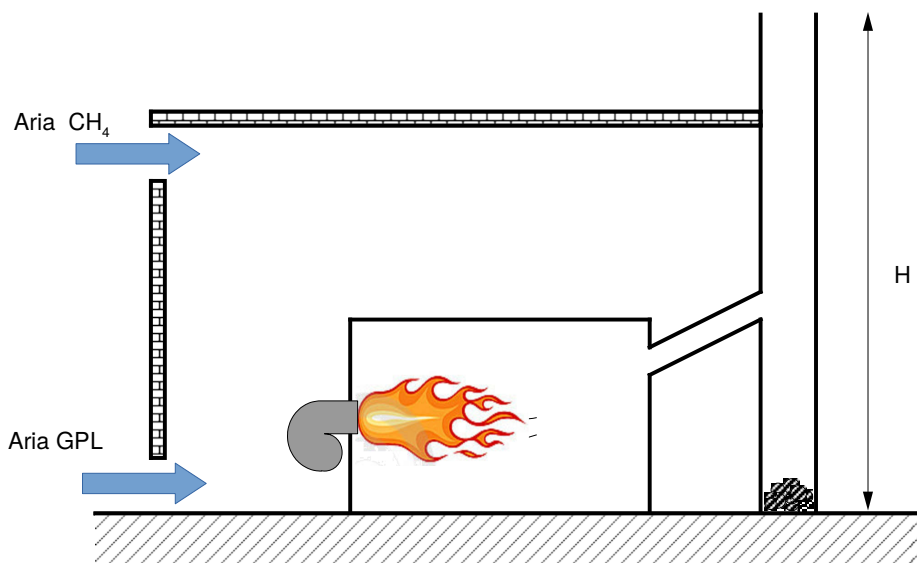

- Pumps circulate water
- in a closed circuit the pumps must only take into account the losses of the circuit
- in a closed circuit the height is not taken into account
- the choice of the pump derives from the size of the system and the losses

Centrifugal Pumps

Characteristic parameters

- volumetric flow [m^3/s] or mass flow [kg/s]
- head as height or pressure
- power
 - power to fluid P_i
 - shaft power P
 - electrical power P_e
- net positive suction head NPSH [m]
- hydraulic efficiency $\eta = \frac{P_i}{P}$
- electrical efficiency $\eta_e = \frac{P}{P_e}$
- global efficiency $\eta_g = \eta \cdot \eta_e = \frac{P_i}{P_e}$

pump laws

absorbed power

$$P = \frac{\dot{m} \cdot g \cdot \Delta z}{\eta} = \frac{q_v \cdot \rho \cdot g \cdot \Delta z}{\eta}$$
$$P = \frac{\dot{m} \cdot v \cdot \Delta p}{\eta} = \frac{q_v \cdot \Delta p}{\eta}$$

pump laws

$$\frac{q_{v1}}{q_{v2}} = \frac{n_1}{n_2}$$
$$\frac{\Delta z_1}{\Delta z_2} = \frac{\Delta p_1}{\Delta p_2} = \left[\frac{\dot{m}_1}{\dot{m}_2} \right]^2$$
$$\eta_1 = \eta_2$$
$$\frac{P_1}{P_2} = \left[\frac{n_1}{n_2} \right]^3 \quad \text{se } \eta_1 = \eta_2$$



pump laws

pump laws, changing diameter

$$\frac{q_{v1}}{q_{v2}} = \frac{D_1}{D_2}$$
$$\frac{\Delta z_1}{\Delta z_2} = \left[\frac{\Delta D_1}{\Delta D_2} \right]^2$$
$$\frac{P_1}{P_2} = \left[\frac{D_1}{D_2} \right]^3$$
$$\eta_1 = \eta_2$$

last two relations are approximations



Performance curve

Pumps

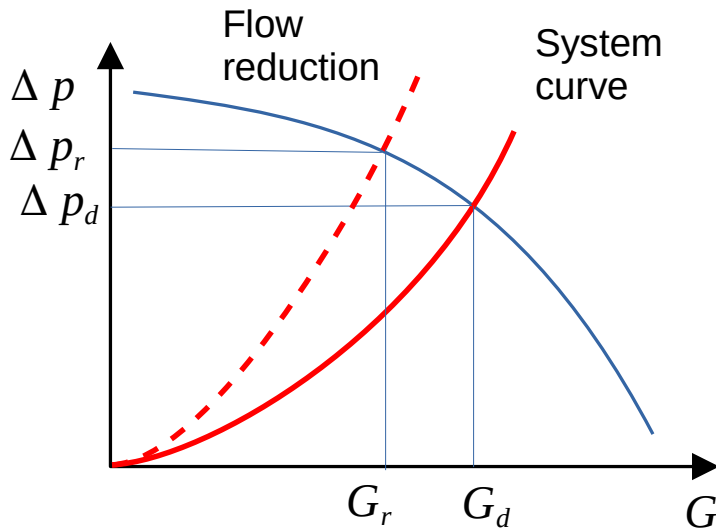

- the characteristic curve describes the pressure-flow relationship
- the operating point is the intersection with the system curve
- varying the system curve, with valves, changes the operating point

Performance curves

variable velocities

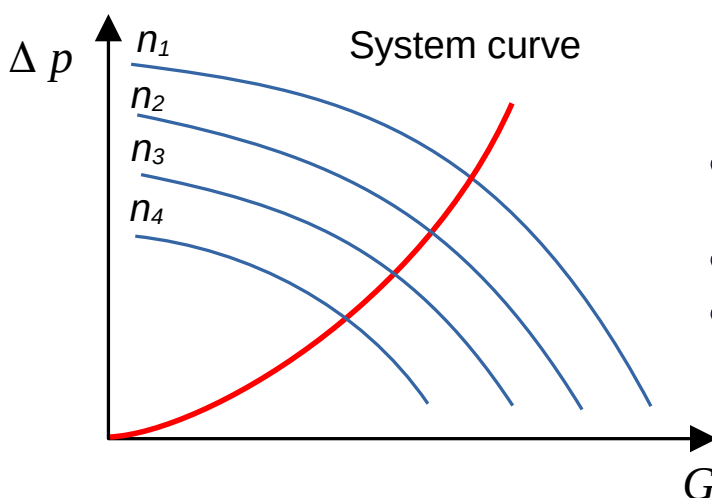

- varying the pump speed varies the characteristic curve
- also varies the operating point
- decreases the flow rate, decreases the head

Performance curve

inverter, constant pressure

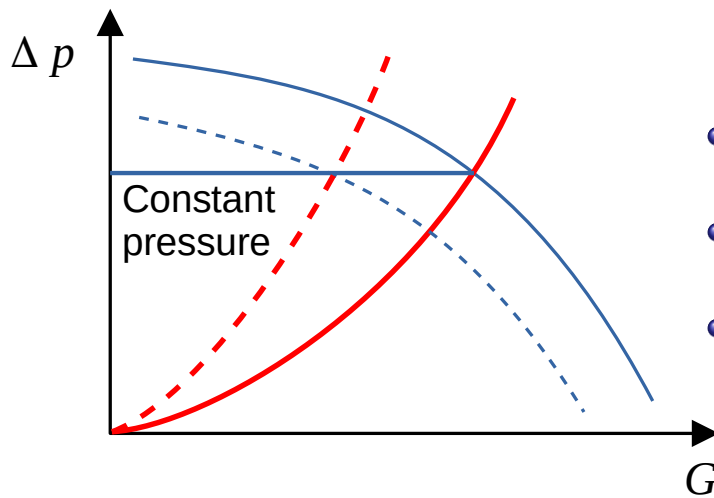

- the pumps speed varies with inverter
- the regulation can be at constant pressure
- the pressure is maintained as the flow rate decreases

Performance curves

inverter, linear pressure

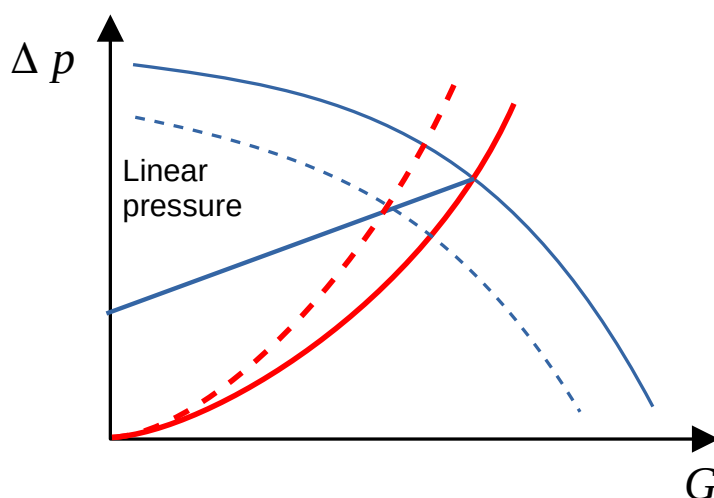

- pumo speed changes using inverter
- pressure changes linearly
- pressure is lower at lower flow rate
- reduces energy costs

coupled pumps

parallel or alternating operation

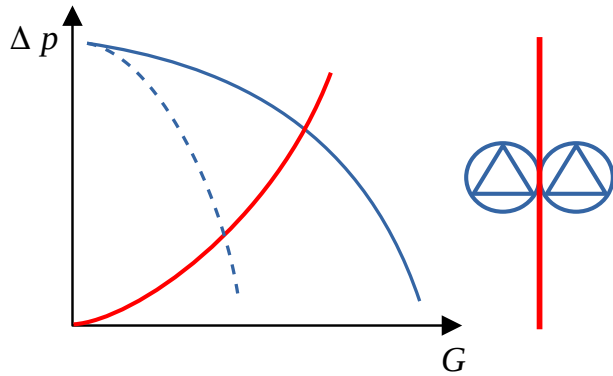

- coupled pumps to increase availability
 - alternating: one pump in standby
 - parallel: with a faulty pump the plant can work with a reduced flow

Valves

kind

2 way

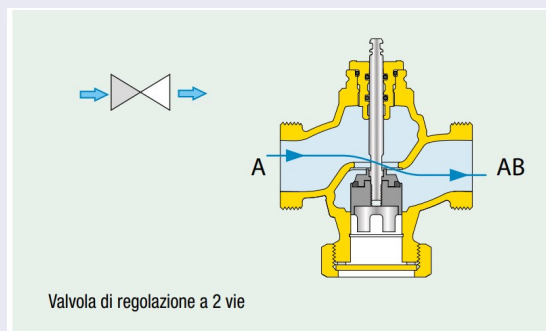

from Caleffi

3 way

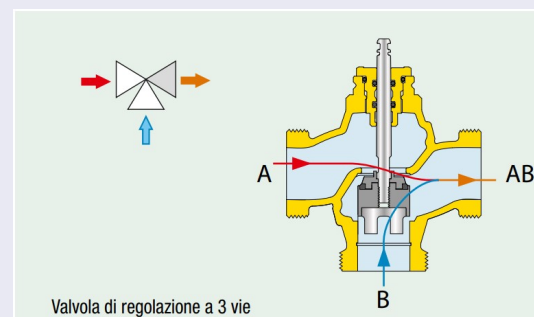

from Caleffi

Valves

type

mixing

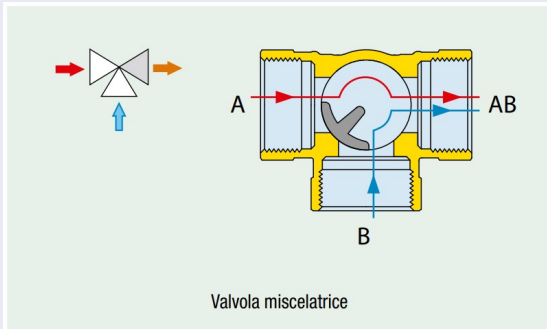

Valvola miscelatrice

from Caleffi

diverting

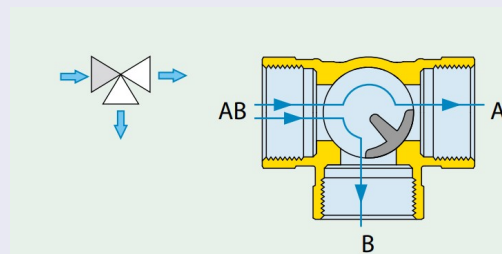

Valvola deviatrice

from Caleffi

Valves

type

Globe

VALVOLE A GLOBO

In queste valvole l'otturatore ha un movimento lineare grazie al collegamento meccanico con un organo mobile detto stelo.

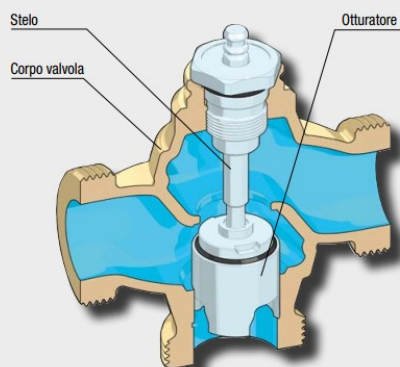

- Richiedono maggior spazio di installazione
- Hanno caratteristiche di regolazione più precise
- Presentano un trafilamento limitato
- Possono raggiungere un'elevata resistenza alla pressione statica

from Caleffi

Gate

VALVOLE A SETTORE

In queste valvole l'otturatore ruota sul proprio asse aprendo le opportune luci sulle sedi della valvola. Il movimento è quindi rotativo.

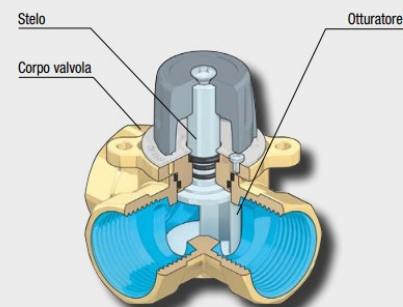

- Sono valvole compatte
- La caratteristica di regolazione è meno precisa
- Sono maggiormente soggette al fenomeno del trafilamento
- Hanno una resistenza limitata alla pressione statica

from Caleffi

System curve

not proportional system curve

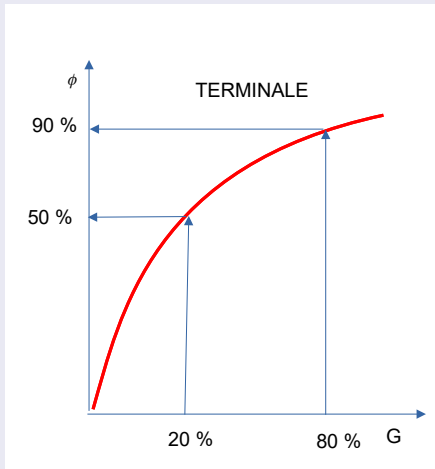

- mass flow and heat release is not proportional
- control problems
- little movement of regulation item result in a large increase of heat released
- linear relationship is sought

Terminal control

linear relationship

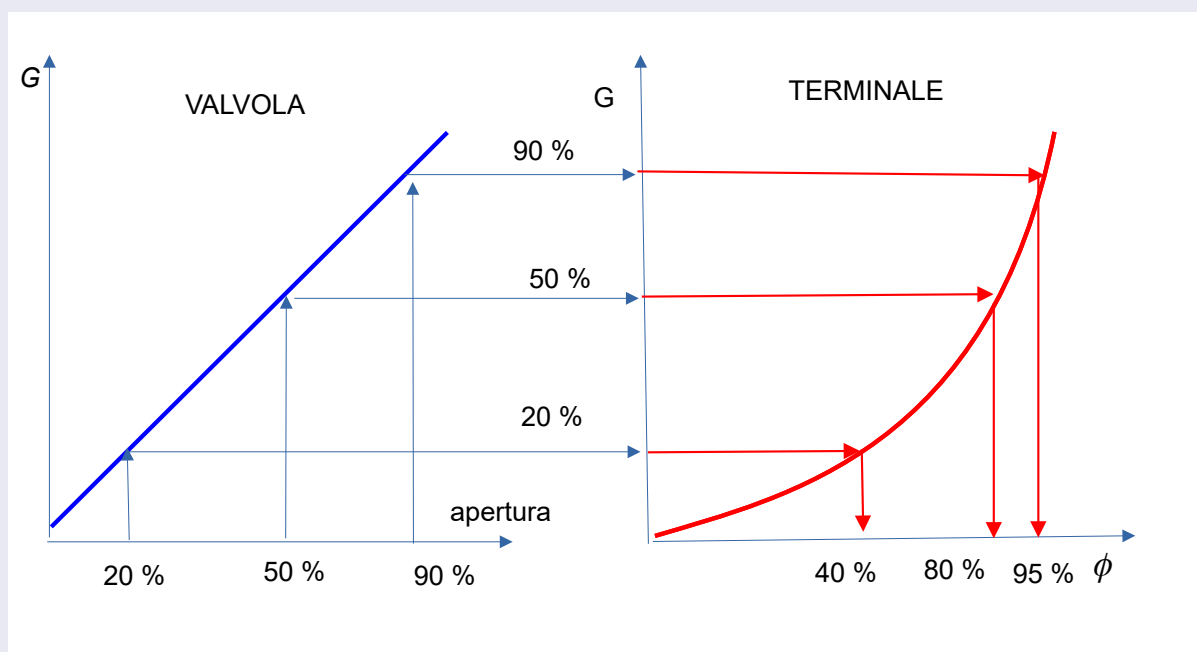

equipercentual control

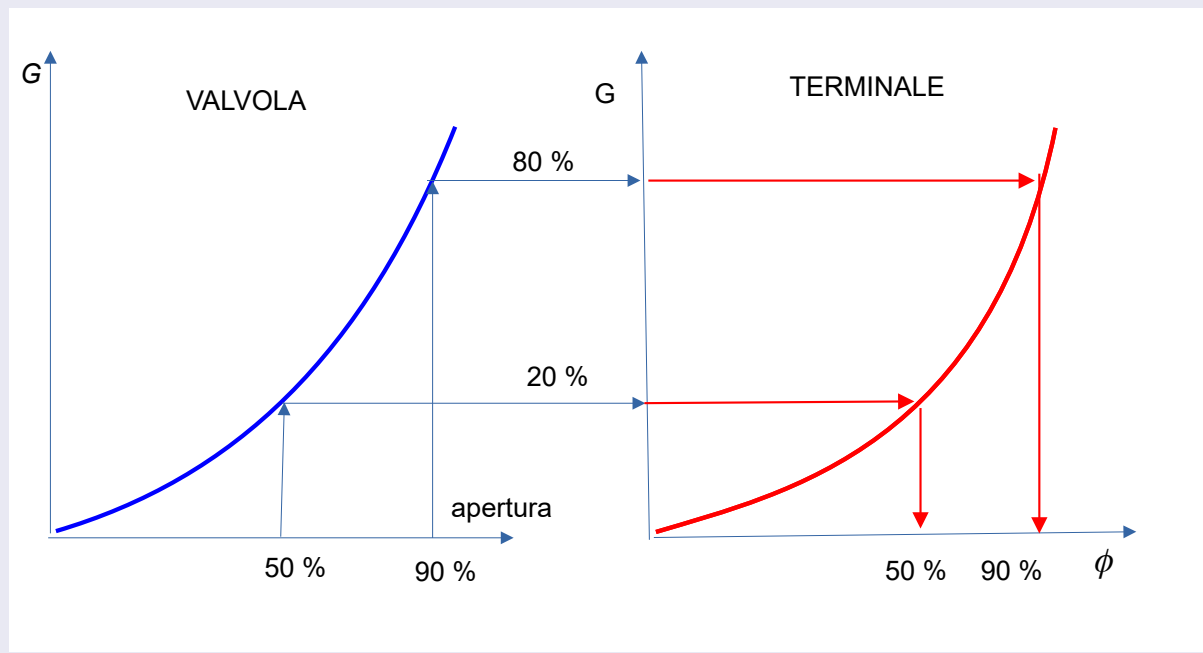

equipecentual valve

equipercentual law

$$G = G_0 \cdot e^{k \cdot h}$$
$$\frac{dG}{dh} = G_0 \cdot k \cdot e^{k \cdot h} = k \cdot G$$
$$\frac{dG}{G} = k \cdot dh$$

G portata

h posizione dello stelo

G_0 parametro

k parametro

Authority

plant control

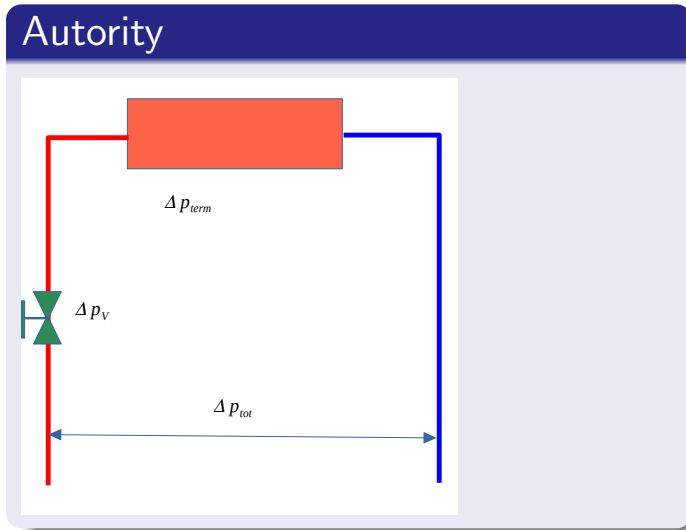

- two way valve for controlling flow
- requires a large head loss to control correctly the flow
- valve authority

$$A = \frac{\Delta p_v}{\Delta p_{tot}} = \frac{\Delta p_v}{\Delta p_v + \Delta p_{circ} + \Delta p_{term}}$$

- desirable a sufficient authority
 $A > 0.5$

Authority

flow with different authority

- two way valve regulates the flow changing the k_v in a range 0- k_{va} full open valve
- obtained flow changes with the authority

relation between G e k_v

$$\Delta p_{tot} = \Delta p_v + \Delta p_{circ} + \Delta p_{term} = \Delta p_v + \Delta p_{imp}$$

$$\Delta p_{imp} = \left(\frac{G}{k_{imp}} \right)^2$$

$$\Delta p_v = \left(\frac{G}{k_v} \right)^2$$

$$\Delta p_{tot} = \left(\frac{G}{k_{imp}} \right)^2 + \left(\frac{G}{k_v} \right)^2 = G^2 \cdot \left(\frac{1}{k_v^2} + \frac{1}{k_{imp}^2} \right)$$

$$G = \sqrt{\frac{\Delta p_{tot}}{1/k_v^2 + 1/k_{imp}^2}}$$

Authority

water flow and authority

Authority

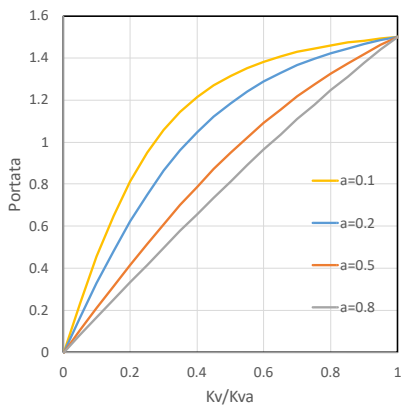

- linear law valve
- changing authority changes the flow
- difficult control with low authority
- desirable $A > 0.5$

Boiler

Non condensing boiler

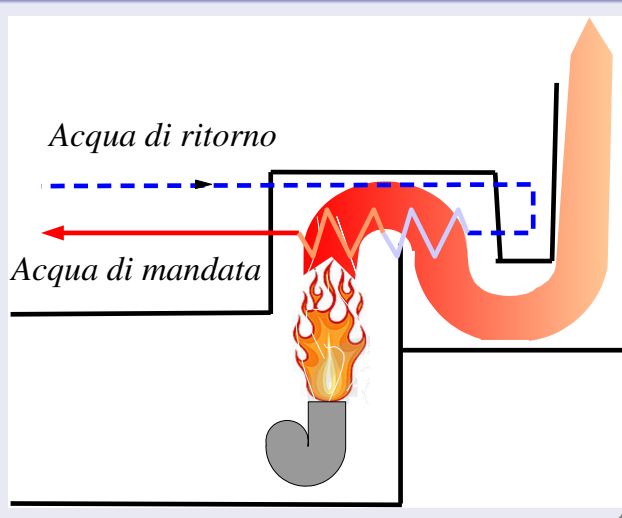

condensing boiler

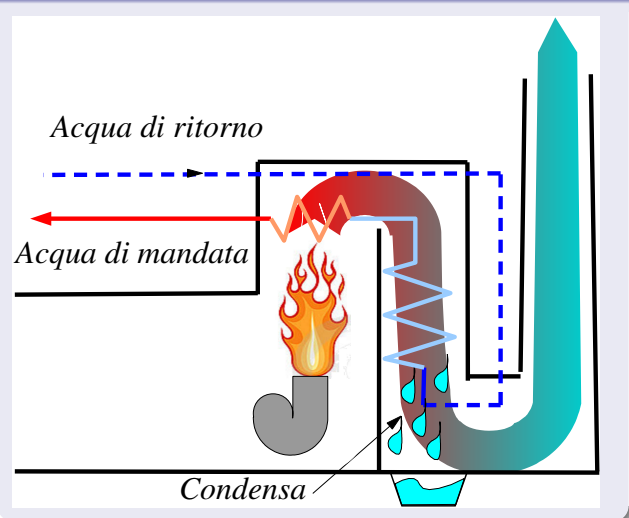

Classification with source

source	Ttype	extraction type
Internal air	Non-renewable if coming from systems using fossil fuels, with the exception of exhaust air	Cooling and dehumidification of internal exhaust air in recovery systems
Rock	Renewable <i>geothermal</i>	Cooling of the subsoil
Soil	Renewable <i>geothermal</i>	Cooling of the subsoil
Groundwater	Renewable <i>geothermal</i>	Cooling of the subsoil
Seawater	Renewable <i>hydrothermal</i>	Cooling of surface water
Lake water	Renewable hydrothermal	Cooling of surface water
River water	Renewable hydrothermal	Cooling of surface water
Waste water and sewage from technological processes	Non-renewable	Cooling of process water and/or sewage
Urban sewage	Similar to renewable	Cooling of urban sewage

Heat pumps

Reference conditions for performance. Heat pumps for heating and domestic hot water production

cold source	Cold source temperautre				Temperature of hot environment	Temperautre environment			T hot environment	
Air	-7	2	7	12	20	35	45	55	45	55
Water		5	10	15	20	35	45	55	45	55
Ground/rock	-5	0	5	10	20	35	45	55	45	55

Limit Temperature

Heat Pumps have some limit running temperatures to be considered

$\theta_{H,off}$ The HP is switched off when external temperature reaches this value, usually 20°C

$\theta_{w,off}$ The HP is switched off when DHW reaches this value, usually 60°C

TOL limit temperature of the cold source, this is determined by the producer

$\theta_{H,cut-off,min}$ design temperature of the cold source at which the HP is switched off

$\theta_{H,cut-off,max}$ design temperature of the hot source at which the HP is switched off

Load factor of heat pump

- depends on the temperature of the hot and cold source
- different values for water and air
- maximum temperature for the temperatures
- the load factor can be determined as:

$$CR = \frac{\Phi_{H,hp,out}}{\Phi_{max,H}}$$

where:

$\Phi_{H,hp,out}$ power required

$\Phi_{max,H}$ maximum power the HP can provide

The power size of HP depends on the load to satisfy

- Ⓐ HP satisfies the whole load
- Ⓑ The HP can satisfy only partially the load, other heat sources should be considered
- Ⓒ other generators are present

In conditions B and C the HP is in bivalent working conditions, the temperature at which $CR = 1$ is the bivalent temperature

HP at balance point

- ① alternating operation: the heat pump is deactivated when the bivalent temperature is reached and the integration generator is activated which supplies the entire thermal power up to the design load;
- ② parallel operation: the heat pump is not deactivated when the bivalent temperature is reached and the integration generator is activated which supplies the residual amount of thermal power;
- ③ partially parallel operation: the heat pump is not deactivated when the bivalent temperature is reached and for higher temperatures the integration generator is activated which must supply the residual power. At the temperature $\theta_{H,cut-off,min}$ the heat pump is deactivated and all the required thermal power must be supplied by the integration generator.

Heat pump working area

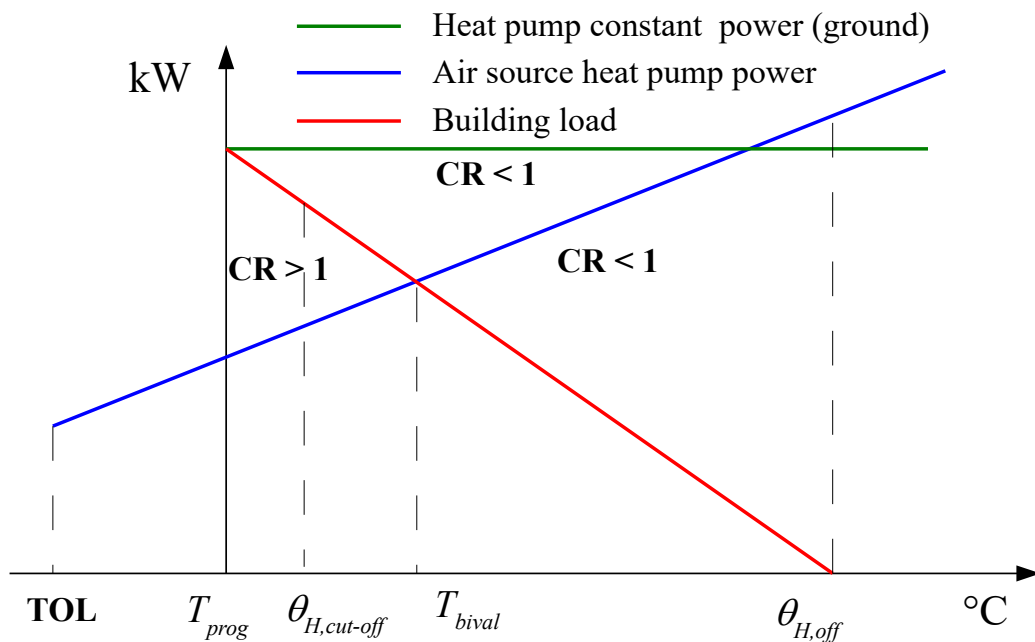

Possible working conditions

- 1 $CR > 1$ e $\theta_f > \theta_{cut-off, min}$ HP at full power, but insufficient to cover the load
- 2 $CR = 1$ HP at full load, the HP cover the entire load
- 3 $CR < 1$ partial power, the HP covers the entire load
- 4 $\theta_f < \theta_{cut-off, min}$, HP switched off
- 5 $\theta_f \leq TOL$, HP switched off

HP in bivalent condition

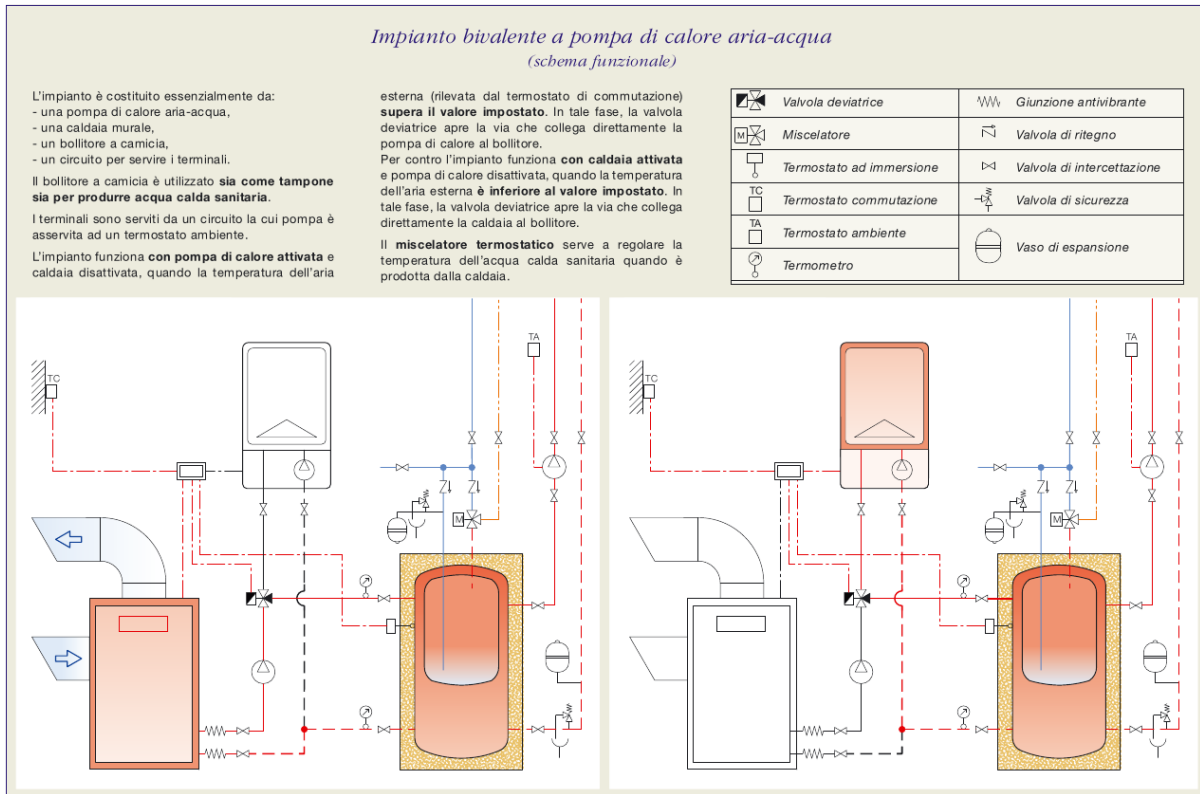

da rivista Idrraulica n 33

Geothermal HP building and plant in Trieste

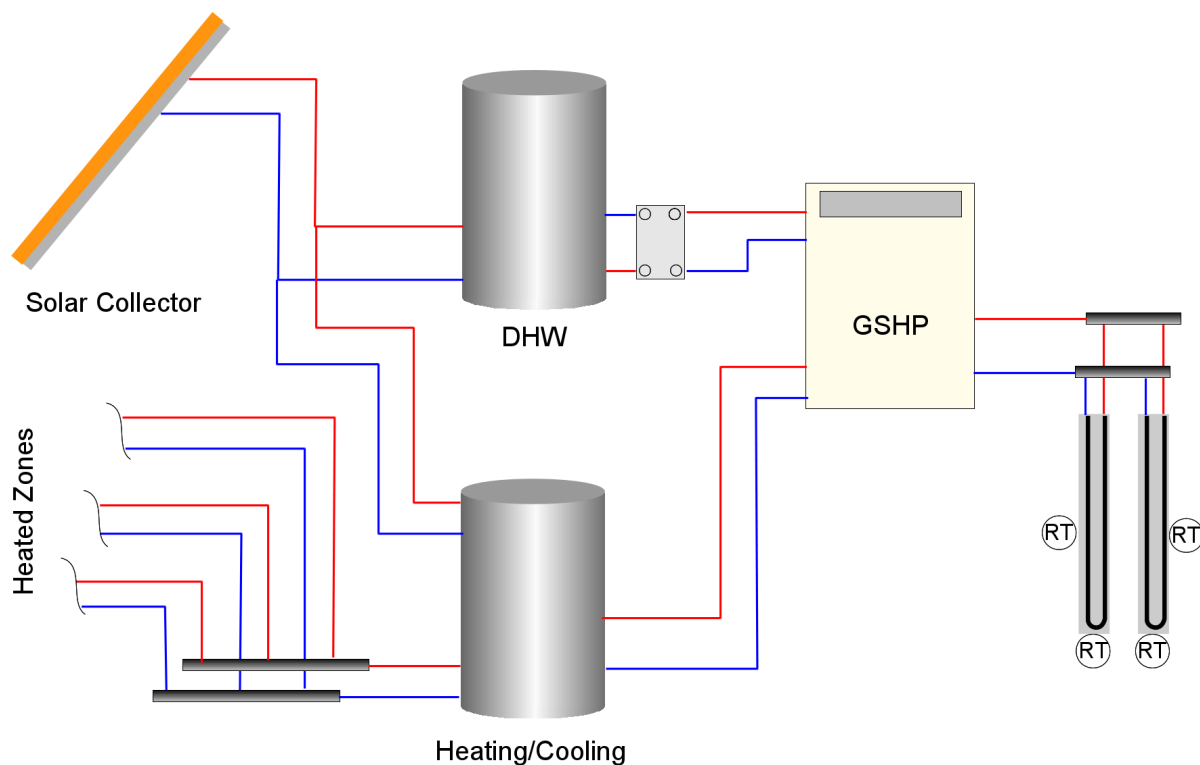

Geothermal HP scheme

Building in Trieste

