



Rules for the Classification of Ships

Effective from 1 January 2023

Part D

Materials and Welding

RINA
Via Corsica, 12 - 16128 Genova - Italy
Tel. +39 01053851 - Fax: +39 0105351000
E-MAIL info@rina.org - WEB www.rina.org

GENERAL CONDITIONS OF THE RULES *effective from 1/1/2021*

Definitions:

"Rules" in these General Conditions means the documents below issued by the Society:

- Rules for the Classification of Ships or other special units;
- Complementary Rules containing the requirements for certification of products, plants, systems and other or containing the requirements for the assignment of additional class notations;
- Rules for the application of statutory rules, containing the rules to perform the duties delegated by Administrations;
- Guides to carry out particular activities connected with Services;
- Any other technical document, as for example rule variations or interpretations.

"Services" means the activities described in Article 1 below, rendered by the Society upon request made by or on behalf of the Interested Party.

"Society" or "RINA" means RINA Services S.p.A. and/or all the companies in the RINA Group which provide the Services.

"Surveyor" means technical staff acting on behalf of the Society in performing the Services.

"Interested Party" means the party, other than the Society, having an interest in or responsibility for the Ship, product, plant or system subject to classification or certification (such as the owner of the Ship and his representatives, the ship builder, the engine builder or the supplier of parts to be tested) who requests the Services or on whose behalf the Services are requested.

"Owner" means the registered Owner, the ship Owner, the manager or any other party with the responsibility, legally or contractually, to keep the ship seaworthy or in service, having particular regard to the provisions relating to the maintenance of class laid down in Part A, Chapter 2 of the Rules for the Classification of Ships or in the corresponding rules indicated in the specific Rules.

"Administration" means the Government of the State whose flag the Ship is entitled to fly or under whose authority the Ship is authorised to operate in the specific case.

"Ship" means ships, boats, craft and other special units, as for example offshore structures, floating units and underwater craft.

"Client" means the Interested Party and any other party who requires the Services.

Article 1

1.1. - The purpose of the Society is, among others, the classification and certification of ships and the certification of their parts and components.

The Society:

- sets forth and develops Rules;
- publishes the Register of Ships;
- issues certificates, statements and reports based on its survey activities.

1.2. - The Society also takes part in the implementation of national and international rules and standards as delegated by various Governments.

1.3. - The Society carries out technical assistance activities on request and provides special services outside the scope of classification, which are regulated by these General Conditions, unless expressly excluded in the particular contract.

Article 2

2.1. - The Rules developed by the Society reflect the level of its technical knowledge at the time they are published. Therefore, the Society, though committed, also through its research and development services, to continuous updating, does not guarantee they meet state-of-the-art science and technology at the time of publication or that they meet the Society's or others' subsequent technical developments.

2.2. - The Interested Party is required to know the Rules on the basis of which the Services are provided. With particular reference to Classification Services, special attention is to be given to the Rules concerning class suspension, withdrawal and reinstatement. In case of doubt or inaccuracy, the Interested Party is to promptly contact the Society for clarification.

The Rules for Classification of Ships are published on the Society's website: www.rina.org.

2.3. - The Society exercises due care and skill:

- in the selection of its Surveyors
- in the performance of its Services, taking into account the level of its technical knowledge at the time the Services are performed.

2.4. - Surveys conducted by the Society include, but are not limited to, visual inspection and non-destructive testing. Unless otherwise required, surveys are conducted through sampling techniques and do not consist of comprehensive verification or monitoring of each component of the Ship or of the items subject to certification. The surveys and checks made by the Society, either on board ships or with remote techniques, do not necessarily

require the constant and continuous presence of the Surveyor. The Society may also commission laboratory testing, underwater inspection and other checks to qualified service suppliers, who will carry out these duties under their responsibility. Survey practices and procedures are selected by the Society based on its experience and knowledge and according to generally accepted technical standards in the sector.

Article 3

3.1. - The class assigned to a Ship, like the reports, statements, certificates or any other document or information issued by the Society, reflect the discretionary opinion of the Society concerning compliance, at the time the Service is provided, of the Ship or product subject to certification, with the applicable Rules (given the intended use and within the relevant time frame).

The Society is under no obligation to make statements or provide information about elements or facts which are not part of the specific scope of the Service requested by the Interested Party or on its behalf.

3.2. - No report, statement, notation on a plan, review, Certificate of Classification, document or information issued or given as part of the Services provided by the Society shall have any legal effect or implication other than a representation that, on the basis of the checks made by the Society, the Ship, structure, materials, equipment, machinery or any other item covered by such document or information meet the Rules. Any such document is issued solely for the use of the Society, its committees and clients or other duly authorised bodies and for no other purpose. Therefore, the Society cannot be held liable for any act made or document issued by other parties on the basis of the statements or information given by the Society. The validity, application, meaning and interpretation of a Certificate of Classification, or any other document or information issued by the Society in connection with its Services, are governed by the Rules of the Society, who is the sole subject entitled to make such authentic interpretation. Any disagreement on technical matters between the Interested Party and the Surveyor in the carrying out of his functions shall be raised in writing as soon as possible with the Society, which will settle any divergence of opinion or dispute.

3.3. - The classification of a Ship, or the issuance of a certificate or other document connected with classification or certification and in general with the performance of Services by the Society shall have the validity conferred upon it by the Rules of the Society at the time of the assignment of class or issuance of the certificate; in no case shall it amount to a statement or warranty of seaworthiness, structural integrity, quality or fitness for a particular purpose or service of any Ship, structure, material, equipment or machinery inspected or tested by the Society.

3.4. - Any document issued by the Society in relation to its activities reflects the condition of the Ship or the subject of certification or other activity at the time of the check.

3.5. - The Rules, surveys and activities performed by the Society, reports, certificates and other documents issued by the Society are in no way intended to replace the duties and responsibilities of other parties including, without limitation, Governments, designers, ship builders, manufacturers, repairers, suppliers, contractors or sub-contractors, Owners, operators, charterers, underwriters, sellers or intended buyers of a Ship or other product or system surveyed.

These documents and activities do not relieve such parties from any fulfilment, warranty, responsibility, duty or obligation (also of a contractual nature) expressed or implied or in any case incumbent on them, nor do they confer on such parties any right, claim or cause of action against the Society. With particular regard to the duties of the ship Owner, the Services undertaken by the Society do not relieve the Owner of his duty to ensure proper maintenance of the Ship and ensure seaworthiness at all times. Likewise, the Rules, surveys performed, reports, certificates and other documents issued by the Society are intended neither to guarantee the buyers of the Ship, its components or any other surveyed or certified item, nor to relieve the seller of the duties arising out of the law or the contract, regarding the quality, commercial value or characteristics of the item which is the subject of transaction. In no case, therefore, shall the Society assume the obligations incumbent upon the above-mentioned parties, even when it is consulted in connection with matters not covered by its Rules or other documents.

In consideration of the above, and within the limits of liability under art. 5 below, the Interested Party undertakes to relieve and hold harmless the Society from any third party claim, as well as from any liability in relation to the latter concerning the Services rendered, where these are attributable to the Interested Party. Insofar as they are not expressly provided for in these General Conditions, the duties and responsibilities of the Owner and Inter-

ested Parties with respect to the services rendered by the Society are described in the Rules applicable to the specific Service rendered.

Article 4

4.1. – Any request for the Society's Services shall be submitted in writing and signed by or on behalf of the Interested Party. Such a request will be considered irrevocable as soon as received by the Society and shall entail acceptance by the applicant of all relevant requirements of the Rules, including these General Conditions. Upon acceptance of the written request by the Society, a contract between the Society and the Interested Party is entered into, which is regulated by the present General Conditions.

4.2. – In consideration of the Services rendered by the Society, the Interested Party and the person requesting the service shall be jointly liable for the payment of the relevant fees and costs, even if the service is not concluded for any cause not pertaining to the Society. In the latter case, the Society shall not be held liable for non-fulfilment or partial fulfilment of the Services requested. In the event of late payment, interest at the legal current rate increased by 2% shall be paid.

4.3. – The contract for the classification of a Ship or for other Services may be terminated and any certificates revoked at the request of one of the parties, subject to at least 30 days' notice to be given in writing. Failure to pay, even in part, the fees due for Services carried out by the Society will entitle the Society to immediately terminate the contract and suspend the Services.

The Society may withhold, suspend or withdraw any certificate, report or service in the event of non-payment of fees due to any member of the RINA Group by the Client in relation to the entire business relationship between any member of the RINA Group and the Client or by any other companies belonging to the same group as the Client. This also applies when the obligation to pay rests with a builder or with the Ship's previous Owner.

For every case of termination or suspension of the contract, the fees for the activities performed until the time of the termination or of the suspension shall be owed to the Society as well as the expenses incurred in view of activities already programmed; this is without prejudice to the right to compensation due to the Society as a consequence of the termination or of the suspension.

With particular reference to Ship classification and certification, unless decided otherwise by the Society, termination of the contract implies that the assignment of class to a Ship is withheld or, if already assigned, that it is suspended or withdrawn; any statutory certificates issued by the Society will be withdrawn in those cases where provided for by agreements between the Society and the flag State.

Article 5

5.1. – In providing the Services, as well as other correlated information or advice, the Society, its Surveyors, servants or agents operate with due diligence for the proper execution of the activity. However, considering the nature of the activities performed (see art. 2.4), it is not possible to guarantee absolute accuracy, correctness and completeness of any information or advice supplied. Express and implied warranties are specifically disclaimed.

Therefore, subject to what provided for in paragraph 5.2 below, and also in the case of activities carried out by delegation of Governments, neither the Society nor any of its Surveyors will be liable for any loss, damage or expense of whatever nature sustained by any person, in tort or in contract, derived from carrying out the Services.

5.2. – Notwithstanding the provisions in paragraph 5.1 above, should any user of the Society's Services prove that he has suffered a loss or damage due to any negligent act or omission of the Society, its Surveyors, servants or agents, then the Society will pay compensation to such person for his proved loss, up to, but not exceeding, five times the amount of the fees charged for the specific services, information or opinions from which the loss or damage derives or, if no fee has been charged, a maximum of one hundred thousand Euro. Where the fees charged are related to a number of Services, the amount of the fees will be apportioned for the purpose of the calculation of the maximum compensation, by reference to the estimated time involved in the performance of the Service from which the damage or loss derives. Any liability for indirect or consequential loss, damage or expense is specifically excluded. In any case, irrespective of the amount of the fees charged, the maximum damages payable by the Society will not be more than 1 million Euro. Payment of compensation under this paragraph will not entail any admission of responsibility and/or liability by the Society and will be made without prejudice to the disclaimer clause contained in paragraph 5.1 above.

5.3. – Any claim for loss or damage of whatever nature by virtue of the provisions set forth herein shall be made to the Society in writing, within the shorter of the following periods: THREE MONTHS

from the date on which the Services were performed or THREE MONTHS from the date on which the damage was discovered. Failure to comply with the above deadline will constitute an absolute bar to the pursuit of such a claim against the Society. **Article 6**

6.1. – Any dispute arising from or in connection with the Rules or with the Services of the Society, including any issues concerning responsibility, liability or limitations of liability of the Society, will be determined in accordance with Italian Law and settled through arbitration assigned to a board of three arbitrators who will proceed in compliance with the Rules of the Chamber of National and International Arbitration of Milan. Arbitration will take place in Genoa, Italy.

6.2. – However, for disputes concerning non-payment of the fees and/or expenses due to the Society for Services, the Society shall have the right to submit any claim to the jurisdiction of the Courts of the place where the registered or operating office of the Interested Party or of the applicant who requested the Service is located. In the case of actions taken against the Society by a third party before a judicial Court, the Society shall also have the right to summon the Interested Party or the subject who requested the Service before that Court, in order to be relieved and held harmless according to art. 3.5 above.

Article 7

7.1. – All plans, specifications, documents and information provided by, issued by, or made known to the Society, in connection with the performance of its Services, will be treated as confidential and will not be made available to any other party other than the Owner without authorisation of the Interested Party, except as provided for or required by any applicable international, European or domestic legislation, Charter or other IACS resolutions, or order from a competent authority. Information about the status and validity of class and statutory certificates, including transfers, changes, suspensions, withdrawals of class, conditions of class, operating conditions or restrictions issued against classed ships and other related information, as may be required, may be published on the website or released by other means, without the prior consent of the Interested Party.

Information about the status and validity of other certificates and statements may also be published on the website or released by other means, without the prior consent of the Interested Party.

7.2. – Notwithstanding the general duty of confidentiality owed by the Society to its clients in clause 7.1 above, the Society's clients accept that the Society will participate in the IACS Early Warning System which requires each Classification Society to provide other involved Classification Societies with relevant technical information on serious hull structural and engineering systems failures, as defined in the IACS Early Warning System (but not including any drawings relating to the ship which may be the specific property of another party), to enable such useful information to be shared and used to facilitate the proper working of the IACS Early Warning System. The Society will provide its clients with written details of such information sent to the involved Classification Societies.

7.3. – In the event of transfer of class, addition of a second class or withdrawal from a double/dual class, the Interested Party undertakes to provide or to permit the Society to provide the other Classification Society with all building plans and drawings, certificates, documents and information relevant to the classed unit, including its history file, as the other Classification Society may require for the purpose of classification in compliance with the applicable legislation and relative IACS Procedure. It is the Owner's duty to ensure that, whenever required, the consent of the builder is obtained with regard to the provision of plans and drawings to the new Society, either by way of appropriate stipulation in the building contract or by other agreement.

In the event that the ownership of the ship, product or system subject to certification is transferred to a new subject, the latter shall have the right to access all pertinent drawings, specifications, documents or information issued by the Society or which have come to the knowledge of the Society while carrying out its Services, even if related to a period prior to transfer of ownership.

Article 8

8.1. – RINA shall not be obliged to perform any obligation towards the Client (including, without limitation, obligation to (a) perform, deliver, accept, sell, purchase, pay or receive money to, from or through a person or entity, or (b) engage in any other act) if this would be in violation of, inconsistent with or expose RINA to punitive measures under any United Nations resolutions and/or under any laws, regulations, decrees, ordinances, orders, demands, requests, rules or requirements of EU, United Kingdom, and/or United States of America and which relate to foreign trade controls, export controls, embargoes or international boycotts

(applying, without limitation, to the financing, payment, insurance, transportation, delivery or storage of product and/or services) hereinafter referred to as "Trade Sanctions".

Recurring the above circumstances during the performance of the contract, RINA shall be entitled at its sole and absolute discretion:

I) to immediately suspend payment or performance of the Services which are the object of the contract until such time as the Trading Sanctions are in force; and/or

II) to a full disengagement from the obligation affected by the Trading Sanctions, in the event that the inability to fulfill the said obligation persists until the term provided for the fulfilment hereunder, provided that where the relevant obligation relates to payments for activities and/or Services which have already been delivered, the affected payment obligation shall remain only suspended until such time as the Trading Sanctions no longer apply to the payment ; and/or

III) to terminate the contract, without prejudice of the RINA's rights pursuant to article 4.3.

Article 9

9.1. – Should any part of these General Conditions be declared invalid, this will not affect the validity of the remaining provisions.

Article 10

10.1. – When the Society provides its Services to a consumer - i.e. a natural person who does not act within the scope of his business or professional activity - the following provisions do not apply: art. 3.2. (as far as the Society is solely entitled to the authentic inter-

pretation of the Rules); art. 4.2., (as far as the payment of the fees is also due for services not concluded due to causes not attributable to the Interested Party); art. 5.1. (as far as the exclusion of liability is concerned); art. 5.2.; art. 5.3.; and art. 6.1. (as far as the jurisdiction of a Board of Arbitrators based in Genoa is concerned).

Article 11

11.1. – RINA and the Interested Party shall promote safety, protect human health and environment and create safe working conditions for their personnel.

11.2. – The Interested Party shall guarantee that the working environment in which RINA's Surveyor will be required to work is adequate, safe and in all respect compliant with the applicable legislation and Rules and shall adopt all necessary measures to mitigate and/or control any relevant risk.

11.3. – Furthermore, in accordance with the applicable legislation and Rules, the Interested Party shall provide RINA with complete and detailed information relevant to any actual or potential specific risk existing in the work areas where the Surveyor will be required to operate and relevant to the performance of the Services as well as with any specific safety measure that RINA Surveyor is requested to comply with.

11.4. – RINA reserves not to commence and/or to suspend the Services and/or to terminate the contract, claiming compensation for any damage occurred, if it considers that the safety requirements listed in this article are not satisfactorily met.

EXPLANATORY NOTE TO PART D

1. Reference edition

The reference edition for Part D is the RINA Rules 2000 edition, which is effective from 1 June 2000.

2. Amendments after the reference edition

2.1 RINA Rules 2000 has been completely rewritten and reorganised.

2.2 Except in particular cases, the Rules are updated and published annually.

3. Effective date of the requirements

3.1 All requirements in which new or amended provisions with respect to those contained in the reference edition have been introduced are followed by a date shown in brackets.

The date shown in brackets is the effective date of entry into force of the requirements as amended by the last updating. The effective date of all those requirements not followed by any date shown in brackets is that of the reference edition.

3.2 Item 6 below provides a summary of the technical changes from the preceding edition. In general, this list does not include those items to which only editorial changes have been made not affecting the effective date of the requirements contained therein.

4. Rule Variations and Corrigenda

Until the next edition of the Rules is published, Rule Variations and/or corrigenda, as necessary, will be published on the RINA web site (www.rina.org). Except in particular cases, paper copies of Rule Variations or corrigenda are not issued.

5. Rule subdivision and cross-references

5.1 Rule subdivision

The Rules are subdivided into six parts, from A to F.

Part A: Classification and Surveys

Part B: Hull and Stability

Part C: Machinery, Systems and Fire Protection

Part D: Materials and Welding

Part E: Service Notations

Part F: Additional Class Notations

Each Part consists of:

- Chapters
- Sections and possible Appendices
- Articles
- Sub-articles
- Requirements

Figures (abbr. Fig) and Tables (abbr. Tab) are numbered in ascending order within each Section or Appendix.

5.2 Cross-references

Examples: Pt A, Ch 1, Sec 1, [3.2.1] or Pt A, Ch 1, App 1, [3.2.1]

- Pt A means Part A

The part is indicated when it is different from the part in which the cross-reference appears. Otherwise, it is not indicated.

- Ch 1 means Chapter 1

The Chapter is indicated when it is different from the chapter in which the cross-reference appears. Otherwise, it is not indicated.

- Sec 1 means Section 1 (or App 1 means Appendix 1)

The Section (or Appendix) is indicated when it is different from the Section (or Appendix) in which the cross-reference appears. Otherwise, it is not indicated.

- [3.2.1] refers to requirement 1, within sub-article 2 of article 3.

Cross-references to an entire Part or Chapter are not abbreviated as indicated in the following examples:

- Part A for a cross-reference to Part A
- Part A, Chapter 1 for a cross-reference to Chapter 1 of Part A.

6. Summary of amendments introduced in the edition 2023

This edition of Part D contains amendments whose effective date is **1 January 2023**.

The date of entry into force of each new or amended item is shown in brackets after the number of the item concerned.



RULES FOR THE CLASSIFICATION OF SHIPS

Part D Materials and Welding

Chapters **1 2 3 4 5**

Chapter 1	GENERAL REQUIREMENTS
Chapter 2	STEEL AND IRON PRODUCTS
Chapter 3	NON FERROUS METAL
Chapter 4	MISCELLANEOUS EQUIPMENT
Chapter 5	WELDING

CHAPTER 1

GENERAL REQUIREMENTS

Section 1 Manufacture, Inspection, Certification

1	General	27
1.1	Application	
1.2	Other specifications	
1.3	Information to be supplied by the purchaser	
2	Manufacture and quality	27
2.1	General	
2.2	Chemical composition	
2.3	Condition of supply	
2.4	Identification of products	
3	Inspection and testing	28
3.1	General conditions	
3.2	Alternative inspection scheme	
3.3	Sampling for mechanical tests	
3.4	Mechanical tests	
3.5	Re-test procedures	
3.6	Visual and dimensional examinations and non-destructive tests	
3.7	Repairs of defects	
4	Identification and certification	30
4.1	Identification and marking	
4.2	Documentation and certification	

Section 2 Testing Procedures for Materials

1	General	32
1.1	Application	
1.2	Testing machines	
1.3	Preparation of test specimens	
2	Tensile test	32
2.1	Test specimens	
2.2	Testing procedure	
3	Bend test	36
3.1	Flat bend test specimen	
3.2	Testing procedure	
4	Impact test	36
4.1	Sampling	
4.2	Charpy V-notch specimens	
4.3	Testing procedure	
4.4	Re-test procedure	
5	Drop weight test	38
5.1	Definition and specimens dimensions	
5.2	Testing procedure	

6	CTOD test (crack tip opening displacement test)	38
	6.1	
7	Ductility tests for pipes and tubes	38
	7.1 Flattening test	
	7.2 Drift expanding test	
	7.3 Flanging test	
	7.4 Ring expanding test	
	7.5 Ring tensile test	
	7.6 Bend test on pipes and tubes	
8	Other tests and checks	40
	8.1 Strain age embrittlement test	
	8.2 Macrographic and micrographic examinations	

Appendix 1 Requirements for NDT Suppliers

1	General	41
	1.1 Scope	
	1.2 Objective	
	1.3 Terms and definitions	
	1.4 References	
2	Requirements	41
	2.1 Requirements for Supplier	
	2.2 Requirements for documents	
	2.3 Quality management system	
	2.4 Qualification and certification of NDT personnel	
	2.5 Supervisor	
	2.6 Operators	
	2.7 Equipment	
	2.8 Work instructions and procedures	
	2.9 Sub-contractors	
	2.10 Reporting	

CHAPTER 2

STEEL AND IRON PRODUCTS

Section 1 Rolled Steel Plates, Sections and Bars

1	General	47
1.1	Application	
1.2	Manufacture	
1.3	Approval	
1.4	Quality of materials	
1.5	Visual, dimensional and non-destructive examinations	
1.6	Rectification of surface defects	
1.7	Condition of supply	
1.8	Sampling and tests	
1.9	Identification and marking	
1.10	Documentation and certification	
2	Normal and higher strength steels for hull and other structural applications	51
2.1	Application	
2.2	Steel grades	
2.3	Manufacture	
2.4	Condition of supply	
2.5	Chemical composition	
2.6	Mechanical Properties	
2.7	Mechanical Tests	
3	High Strength Steels for Welded Structures	61
3.1	Application	
3.2	Steel grades	
3.3	Condition of supply	
3.4	Approval	
3.5	Method of Manufacture	
3.6	Chemical composition	
3.7	Delivery Condition - Rolling Process and Heat Treatment	
3.8	Mechanical properties	
3.9	Traceability	
3.10	Re-test procedures	
3.11	Through thickness tensile test	
3.12	Tolerances	
3.13	Surface Quality	
3.14	Internal Soundness	
3.15	Stress relieving heat treatment and other heat treatments	
3.16	Facilities for Inspection	
3.17	Identification of Materials	
3.18	Branding	
3.19	Documentation of Inspection Tests	
4	Steels for boilers and pressure vessels	68
4.1	Application	
4.2	Steel grades	
4.3	Manufacture	
4.4	Condition of supply	
4.5	Chemical composition	
4.6	Mechanical properties	
4.7	Mechanical properties at elevated temperatures	

	4.8	Mechanical tests	
5		Ferritic steels for low temperature service	72
	5.1	Application	
	5.2	Steel grades	
	5.3	Manufacture	
	5.4	Condition of supply	
	5.5	Chemical composition	
	5.6	Mechanical properties	
	5.7	Mechanical tests	
6		Steels for machinery	75
	6.1	Application	
	6.2	Steel grades and relevant properties	
	6.3	Manufacture and condition of supply	
	6.4	Mechanical tests	
7		Stainless steel products	76
	7.1	Application	
	7.2	Steel grades	
	7.3	Manufacture	
	7.4	Condition of supply	
	7.5	Chemical composition	
	7.6	Mechanical properties	
	7.7	Mechanical tests	
	7.8	Metallographic structure inspection	
	7.9	Intergranular corrosion test	
	7.10	Through thickness tests	
8		Clad steel plates	78
	8.1	Application	
	8.2	Steel grades	
	8.3	Manufacture	
	8.4	Condition of supply	
	8.5	Chemical composition	
	8.6	Mechanical properties	
	8.7	Mechanical tests	
	8.8	Corrosion testing	
	8.9	Ultrasonic testing	
	8.10	Surface defects and repairs	
	8.11	Adhesion defects in the cladding and repairs	
9		Steels with specified through thickness properties	80
	9.1	Application	
	9.2	Steel grades	
	9.3	Manufacture	
	9.4	Chemical composition	
	9.5	Mechanical properties	
	9.6	Test Procedure	
	9.7	Tensile test results	
	9.8	Re-test procedure	
	9.9	Ultrasonic testing	
	9.10	Marking	
	9.11	Certification	
10		Extremely Thick Steel Plates in container ships	82
	10.1	Application	
	10.2	Steel grades	
	10.3	Thickness	

	10.4 Hull structure (for purpose of design)	
	10.5 Non-Destructive Testing during construction (Measure No 1 of Appendix 1)	
	10.6 Periodic NDT after delivery (Measure No.2 of Appendix 1)	
	10.7 Brittle crack arrest design (Measures No.3, 4 and 5 of Appendix 1)	
11	YP47 Steels and Brittle Crack Arrest Steels	85
	11.1 Scope	
	11.2 Material specifications	
	11.3 Manufacturing approval	
	11.4 Welding of YP47 steels	
	11.5 Welding of brittle crack arrest steels	
12	Normal and higher strength corrosion resistant steels for cargo oil tanks	89
	12.1 Scope	
	12.2 Approval	
	12.3 Method of manufacture	
	12.4 Chemical composition	
	12.5 Condition of supply	
	12.6 Mechanical properties	
	12.7 Freedom from defects	
	12.8 Tolerances	
	12.9 Identification of materials	
	12.10 Testing and inspection	
	12.11 Test material	
	12.12 Test specimens	
	12.13 Number of test specimens	
	12.14 Branding	
	12.15 Documentation	

Section 2 Steel Pipes, Tubes and Fittings

1	General	93
	1.1 Application	
	1.2 Manufacture	
	1.3 Approval	
	1.4 Quality of materials	
	1.5 Visual, dimensional and non-destructive examinations	
	1.6 Rectification of surface defects	
	1.7 Condition of supply	
	1.8 Hydrostatic test	
	1.9 Sampling and testing	
	1.10 Identification and marking	
	1.11 Documentation and certification	
2	Pipes for pressure systems operating at ambient temperature	95
	2.1 Application	
	2.2 Steel grades	
	2.3 Condition of supply	
	2.4 Chemical composition	
	2.5 Mechanical properties	
	2.6 Mechanical and technological tests	
3	Pipes for structural applications	96
	3.1 Application	
	3.2 Steel grades	

4	Pipes for high temperature service	96
	4.1 Application	
	4.2 Steel grades	
	4.3 Condition of supply	
	4.4 Chemical composition	
	4.5 Mechanical properties	
	4.6 Mechanical properties at elevated temperatures	
	4.7 Mechanical and technological tests	
5	Ferritic steel pipes for pressure service at low temperature	99
	5.1 Application	
	5.2 Steel grades	
	5.3 Condition of supply	
	5.4 Chemical composition	
	5.5 Mechanical properties	
	5.6 Mechanical and technological tests	
6	Austenitic and austenitic-ferritic stainless steel pipes	101
	6.1 Application	
	6.2 Steel grades	
	6.3 Condition of supply	
	6.4 Chemical composition	
	6.5 Mechanical properties	
	6.6 Mechanical and technological tests	
	6.7 Corrosion tests	
7	Fittings	103
	7.1 Application	
	7.2 Steel grades and relevant properties	
	7.3 Condition of supply	
	7.4 Mechanical properties	
	7.5 Mechanical and technological tests	
	7.6 Non-destructive examination	
	7.7 Marking and certification	

Section 3 Steel Forgings

1	General	104
	1.1 Application	
	1.2 Classification of forgings	
	1.3 Manufacture	
	1.4 Approval	
	1.5 Quality of materials	
	1.6 Visual and dimensional examination	
	1.7 Non-destructive examination	
	1.8 Rectification of defects	
	1.9 Condition of supply	
	1.10 Pressure test	
	1.11 Sampling and testing	
	1.12 Identification and marking	
	1.13 Documentation and certification	
2	Forgings for hull and other welded structures in general	108
	2.1 Application	
	2.2 Steel grades	
	2.3 Condition of supply	
	2.4 Chemical composition	

	2.5	Mechanical properties	
	2.6	Mechanical tests	
	2.7	Non-destructive examination	
3		Forgings for machinery, shafts and equipment	109
	3.1	Application	
	3.2	Steel grades	
	3.3	Condition of supply	
	3.4	Chemical composition	
	3.5	Mechanical properties	
	3.6	Mechanical tests	
	3.7	Non-destructive examination	
	3.8	Additional approval tests of alloy steel used for intermediate shafts	
4		Forgings for crankshafts	111
	4.1	Application	
	4.2	Steel grades	
	4.3	Manufacture	
	4.4	Condition of supply	
	4.5	Chemical and mechanical properties	
	4.6	Mechanical tests	
	4.7	Non-destructive examination	
5		Forgings for gearing	113
	5.1	Application	
	5.2	Steel grades	
	5.3	Manufacture	
	5.4	Condition of supply	
	5.5	Chemical and mechanical properties	
	5.6	Mechanical tests for normalised and tempered or quenched and tempered forgings	
	5.7	Mechanical tests for surface-hardened forgings	
	5.8	Non-destructive examination	
6		Forgings for turbines	115
	6.1	Application	
	6.2	Steel grades, chemical composition and mechanical properties	
	6.3	Condition of supply	
	6.4	Mechanical tests	
	6.5	Non-destructive examination	
	6.6	Thermal stability test	
7		Forgings for boilers, pressure vessels and systems	117
	7.1	Application	
	7.2	Steel grades	
	7.3	Condition of supply	
	7.4	Chemical composition	
	7.5	Mechanical properties	
	7.6	Mechanical properties at elevated temperature	
	7.7	Mechanical tests	
	7.8	Non-destructive examination	
8		Ferritic steel forgings for low temperature service	118
	8.1	Application	
	8.2	Steel grades and relevant properties	
	8.3	Condition of supply	
	8.4	Mechanical tests	
	8.5	Non-destructive examination	

9	Stainless steel forgings	118
----------	---------------------------------	------------

- 9.1 Application
- 9.2 Steel grades and relevant properties
- 9.3 Mechanical tests
- 9.4 Non-destructive examination
- 9.5 Corrosion tests

Section 4 Steel Castings

1	General	123
----------	----------------	------------

- 1.1 Application
- 1.2 Classification of castings
- 1.3 Manufacture
- 1.4 Approval
- 1.5 Quality of materials
- 1.6 Visual and dimensional examination
- 1.7 Non-destructive examination
- 1.8 Rectification of defects
- 1.9 Condition of supply - heat treatment
- 1.10 Pressure test
- 1.11 Sampling and testing
- 1.12 Identification and marking
- 1.13 Documentation and certification

2	Casting for hull and other welded structures in general	127
----------	--	------------

- 2.1 Application
- 2.2 Steel grades
- 2.3 Condition of supply
- 2.4 Chemical composition
- 2.5 Mechanical properties
- 2.6 Mechanical tests
- 2.7 Non-destructive examination

3	Castings for machinery and equipment	128
----------	---	------------

- 3.1 Application
- 3.2 Steel grades
- 3.3 Condition of supply
- 3.4 Chemical composition
- 3.5 Mechanical properties
- 3.6 Mechanical tests
- 3.7 Non-destructive examination

4	Castings for crankshafts	129
----------	---------------------------------	------------

- 4.1 Application
- 4.2 Steel grades
- 4.3 Manufacture
- 4.4 Condition of supply
- 4.5 Chemical and mechanical properties
- 4.6 Mechanical tests
- 4.7 Non-destructive examinations and rectification of defects

5	Castings for boilers, pressure vessels and systems	130
----------	---	------------

- 5.1 Application
- 5.2 Steel grades
- 5.3 Condition of supply
- 5.4 Chemical composition and mechanical properties
- 5.5 Mechanical properties at elevated temperature

5.6	Mechanical tests	
5.7	Non-destructive examination	
6	Ferritic steel castings for low temperature service	132
6.1	Application	
6.2	Steel grades	
6.3	Condition of supply	
6.4	Chemical composition and mechanical properties	
6.5	Mechanical tests	
6.6	Non-destructive examination	
7	Stainless steel castings	132
7.1	Application	
7.2	Steel grades and relevant properties	
7.3	Mechanical tests	
7.4	Non-destructive examination	
7.5	Corrosion tests	

Section 5 Iron Castings

1	General	135
1.1	Application	
1.2	Casting designation	
1.3	Manufacture	
1.4	Quality of castings	
1.5	Visual, dimensional and non-destructive examination	
1.6	Repair of defects	
1.7	Chemical composition	
1.8	Condition of supply	
1.9	Sampling and testing	
1.10	Identification and marking	
1.11	Documentation and certification	
2	Grey iron castings	136
2.1	Application	
2.2	Test material	
2.3	Mechanical properties	
3	Spheroidal or nodular graphite iron castings	137
3.1	Application	
3.2	Manufacture and condition of supply	
3.3	Test material	
3.4	Test and mechanical properties	
3.5	Metallographic examination	
3.6	Non-destructive examination	

Appendix 1 Measures for Extremely Thick Steel Plates

1	Measures	140
1.1	General	

Appendix 2 ESSO Test

1	Scope	141
	1.1	
2	Symbols	141
	2.1	
3	Purpose	142
	3.1	
4	Standard test specimen	142
	4.1	
5	Test equipment	142
	5.1	
6	Test preparations	142
	6.1	
7	Test method	143
	7.1	
8	Test results	143
	8.1	
9	Report	143
	9.1	

Appendix 3 Additional Approval Procedure for Corrosion Resistant Steel

1	Scope	145
	1.1	
2	Application for approval	145
	2.1	
3	Approval of test plan	145
	3.1 General	
	3.2 Method for selection of test samples	
	3.3	
4	Carrying out the approval test	146
	4.1	
5	Attendance of the Society's Surveyor for the tests	146
	5.1	
6	Test results	146
	6.1	
7	Assessment criteria for the results of corrosion resistance tests of welded joints	146
	7.1	

Appendix 4 Test Method for Brittle Crack Arrest Toughness, Kca

1	General	147
	1.1 Application	
	1.2 Scope	
	1.3 Symbols and their significance	
2	Testing equipment	147
	2.1 General	
	2.2 Testing machine	
	2.3 Impact equipment	
3	Test specimens	148
	3.1 Test specimen shapes	
	3.2 Shapes of tab plates and pin chucks	
	3.3 Welding of test specimen and tab plates	
4	Test methods	152
	4.1 General	
	4.2 Temperature control methods	
	4.3 Crack initiation methods	
5	Test procedures	153
	5.1 General	
	5.2 Pretest procedures	
	5.3 Loading procedures	
	5.4 Procedures after testing	
	5.5 Observation of fracture surfaces	
6	Determination of arrest toughness	154
	6.1 Judgment of arrested crack	
	6.2 Assessment of impact energy	
	6.3 Calculation of arrest toughness	
7	Reporting	156
	7.1 General	
8	ANNEX A: Method for obtaining Kca at a specific temperature and the evaluation	158
	8.1 General	
	8.2 Method	
	8.3 Evaluation	
9	ANNEX B: Double tension type arrest test	158
	9.1 Features of this test method	
	9.2 Test specimen shapes	
	9.3 Temperature conditions and temperature control methods	
	9.4 Secondary loading method	

Appendix 5 Outline of requirements for undertaking isothermal Crack Arrest Temperature (CAT) test

1	General	160
	1.1 Scope	
	1.2 Symbols and their significance	

2	Testing equipment	160
	2.1 General	
3	Test specimens	160
	3.1 Impact type crack initiation	
	3.2 Double tension type crack initiation	
	3.3 Embrittled zone setting	
	3.4 Side grooves	
	3.5 Nominal length of embrittled zone	
	3.6 Tab plate / pin chuck details and welding of test specimen to tab plates	
4	Test method	163
	4.1 Preloading	
	4.2 Temperature measurement and control	
	4.3 Loading and brittle crack initiation	
5	Measurements after test and test validation judgement	165
	5.1 Brittle crack initiation and validation	
	5.2 Crack path examination and validation	
	5.3 Fracture surface examination, crack length measurement and their validation	
6	Judgement of "arrest" or "propagate"	166
	6.1 General	
7	Ttest, Tarrest and CAT determination	166
	7.1 Ttest determination	
	7.2 Tarrest determination	
	7.3 CAT determination	
8	Reporting	167
	8.1 General	
9	Use of test for material qualification testing	167
	9.1 General	

Appendix 6 Material and Welding for the Storage and Transport of Liquefied Gases in Bulk and for the Use of Gases or Other Low-Flashpoint Fuels

1	General	169
	1.1 Application	
2	Material requirements	169
	2.1 Plates, pipes (seamless and welded), sections and forgings for cargo tanks, fuel tanks and process pressure vessels for design temperatures not lower than 0°C	
	2.2 Plates, sections and forgings for cargo tanks, fuel tanks, secondary barriers and process pressure vessels for design temperatures below 0°C and down to -55°C	
	2.3 Plates, sections and forgings for cargo tanks, fuel tanks, secondary barriers and process pressure vessels for design temperatures below -55°C and down to -165°C	

CHAPTER 3

NON FERROUS METAL

Section 1 Copper and Copper Alloys

1	General	173
1.1	Application	
1.2	Manufacture	
1.3	Testing	
1.4	Documentation and certification	
2	Copper alloy castings	173
2.1	Application	
2.2	Manufacture	
2.3	Condition of supply	
2.4	Chemical composition	
2.5	Mechanical properties	
2.6	Mechanical tests	
2.7	Visual and non-destructive examination	
2.8	Rectification of defective castings	
2.9	Identification and marking	
3	Copper alloy pipes	175
3.1	Application	
3.2	Condition of supply	
3.3	Chemical composition	
3.4	Mechanical properties	
3.5	Mechanical tests	
3.6	Stress corrosion cracking test	
3.7	Hydrostatic test - Eddy current test	
3.8	Visual and non-destructive examination	
3.9	Rectification of defects	
3.10	Identification and marking	

Section 2 Aluminium Alloys

1	General	178
1.1	Application	
1.2	Manufacture	
2	Wrought aluminium alloy products (plates, bars, sections and tubes)	178
2.1	Application	
2.2	Aluminium grades	
2.3	Manufacture	
2.4	Chemical composition	
2.5	Corrosion testing	
2.6	Mechanical properties	
2.7	Mechanical tests	
2.8	Testing	
2.9	Re-test procedures	
2.10	Hydrostatic test	
2.11	Visual and non-destructive examination	

3	Rivets	184
3.1	Application	
3.2	Chemical composition and heat treatment	
3.3	Heat treatment	
3.4	Test material	
3.5	Mechanical tests	
3.6	Identification	
3.7	Certification	
4	Transition joints	185
4.1	General	
4.2	Manufacture	
4.3	Visual and non-destructive examination	
4.4	Inspection	
5	Aluminium alloy castings	186
5.1	General	
5.2	Aluminium grades	
5.3	Manufacture	
5.4	Chemical composition	
5.5	Mechanical properties	
5.6	Mechanical tests	

CHAPTER 4

MISCELLANEOUS EQUIPMENT

Section 1 Equipment

1	Anchors	191
1.1	Application	
1.2	Design - Manufacture	
1.3	Materials - testing	
1.4	Visual and dimensional examination	
1.5	Drop test and hammering test	
1.6	Proof load test	
1.7	Identification, marking, certification	
1.8	Painting	
2	Stud link chain cables and accessories	195
2.1	Application	
2.2	Chain cable grades	
2.3	Approval of chain cable Manufacturers	
2.4	Steels for chain cables	
2.5	Rolled steel bars	
2.6	Forged steels for chain cables and accessories	
2.7	Cast steels for chain cables and accessories	
2.8	Materials for studs	
2.9	Design and manufacture	
2.10	Testing of finished chain cables	
2.11	Testing of accessories	
3	Studless chain cables	203
3.1	Application	
3.2	Materials for studless chain cables	
3.3	Testing of finished chain cables	
4	Steel wire ropes	205
4.1	Application	
4.2	Manufacture	
4.3	Types of ropes	
4.4	Sampling and testing	
4.5	Identification marking and certification	
5	Fibre ropes	211
5.1	Application	
5.2	Manufacture	
5.3	Type of ropes	
5.4	Sampling and testing	
5.5	Identification, marking and certification	
6	Side scuttles, windows and their glass panes	213
6.1	Application	
6.2	Manufacture	
6.3	Inspections and tests	
6.4	Identification and marking	

Section 2 Various Finished Products

1	Cast copper alloy propellers and propellers blades	216
1.1	Application	
1.2	Manufacture	
1.3	Quality of castings	
1.4	Condition of supply	
1.5	Dimensions, dimensional and geometrical tolerances	
1.6	Chemical composition and metallurgical characteristics	
1.7	Mechanical properties and tests	
1.8	Sampling and testing	
1.9	Inspection, definition of skew and severity zones	
1.10	Non-destructive testing (NDT)	
1.11	Acceptance criteria for liquid penetrant testing	
1.12	Repair of defects	
1.13	Straightening	
1.14	Identification and marking	
1.15	Manufacturer's certificates	
2	Pressure bottles	225
2.1	Application	
2.2	Manufacture	
2.3	Inspection and tests	
2.4	Identification, marking and certification	
3	Cast steel propellers and propeller blades	226
3.1	Application	
3.2	Manufacture	
3.3	Quality of castings	
3.4	Condition of supply	
3.5	Dimensions, dimensional and geometrical tolerances	
3.6	Chemical composition	
3.7	Mechanical properties	
3.8	Sampling	
3.9	Definition of skew, severity zones	
3.10	Non-destructive testing	
3.11	Acceptance criteria for liquid penetrant testing and magnetic particle testing	
3.12	Repair of defects	
3.13	Identification and marking	
3.14	Document and certification	

CHAPTER 5 WELDING

Section 1 General Requirements

1	Application	233
1.1	General	
2	Fabrication by welding	233
2.1	General	
2.2	Approval	
2.3	Welding procedures	
2.4	Type of joints, edge preparations and size	
2.5	Welding execution and control	

Section 2 Approval of Welding Consumables

1	General	235
1.1	Application	
1.2	Grading	
1.3	Manufacture	
2	Approval procedure	236
2.1	Plant inspection	
2.2	Test assemblies	
2.3	Firms with several factories - sister firms	
2.4	Annual inspection and tests	
2.5	Alterations to approved consumables	
2.6	Upgrading and upgrading	
2.7	Additional tests	
2.8	Manufacturer's responsibilities	
3	Mechanical testing procedure	237
3.1	Test specimens	
3.2	Testing procedures	
3.3	Re-test procedures	
4	Covered electrodes for manual arc welding	238
4.1	General	
4.2	Deposited metal tests	
4.3	Butt weld tests	
4.4	Hot cracking test	
4.5	Hydrogen test	
4.6	Covered electrodes for manual fillet welding	
4.7	Covered electrodes for gravity or contact welding	
4.8	Annual tests and upgrading	
5	Wire flux combinations for submerged arc welding	243
5.1	General	
5.2	Approval tests for multi-run technique	
5.3	Approval tests for two run techniques	
5.4	Annual tests - upgrading	

6	Wires and wire-gas combinations for metal arc welding	248
6.1	General	
6.2	Approval for semi-automatic multi-run welding	
6.3	Approval for automatic multi-run welding	
6.4	Approval for automatic two-run welding	
6.5	Annual tests and up-grading	
7	Consumables for use in electroslag and electrogas vertical welding	251
7.1	General	
7.2	Butt weld tests	
7.3	Annual tests and up-grading	
8	Approval of Welding Consumables for High Strength Steels for Welded Structures	253
8.1	Application	
8.2	Grading and designation	
8.3	Manufacture, testing and approval procedure	
8.4	Hydrogen test	
8.5	Annual repeat test	
9	Consumables for welding Mo and Cr-Mo steels	257
9.1	Application	
9.2	Approval tests	
9.3	Test requirements	
9.4	Periodical control tests	
10	Consumables for welding Ni steels for low temperature applications	258
10.1	Application	
10.2	Approval tests	
10.3	Tests requirements	
10.4	Annual control tests	
11	Consumables for welding Cr-Ni austenitic and austenitic-ferritic stainless steels	259
11.1	Application	
11.2	Approval tests	
11.3	Test requirements	
11.4	Annual control tests	
12	Consumables for welding aluminium alloys	261
12.1	Application	
12.2	Approval tests	
12.3	Test requirements	
12.4	Annual control tests	

Section 3 Approval of Over Weldable Shop Primers

1	Application	265
1.1	General	
2	Information and documentation to be submitted	265
2.1	General	
3	Approval tests	265
3.1	General	
3.2	Base material	

3.3	Filler metal	
3.4	Type and dimension of test samples	
3.5	Number of samples required	
3.6	Operational procedures	
3.7	Test requirements	
3.8	Re-tests	
4	Certification	266
4.1		
5	Periodical control tests	266
5.1		

Section 4 Approval of Welding Procedures

1	General	267
1.1	Application	
1.2	Welding procedure	
2	Welding procedures for C and C-Mn steels	268
2.1	Butt weld on plates	
2.2	T butt-joint on plates	
2.3	T fillet joint	
2.4	Butt weld on pipes	
2.5	Re-testing	
2.6	Test record	
2.7	Range of approval	
3	Welding procedures for Cr-Ni austenitic and austenitic-ferritic stainless steels for application with chemicals	278
3.1	General	
4	Approval of welding procedures for high strength quenched and tempered steels	279
4.1	General	
5	Approval of welding procedures for forgings and castings	279
5.1	General	
6	Approval of welding procedures for aluminium alloys	279
6.1	Butt weld on plates	
6.2	T fillet joint	
6.3	Range of approval	
7	Approval of welding procedure qualification tests for repair of propellers	282
7.1	General	
7.2	Test piece and welding of sample	
7.3	Examination and tests	
7.4	Additional test for cast steel propellers	
7.5	Re-testing	
7.6	Test record	
7.7	Range of approval	

Section 5 Approval of CO₂ Laser Welding Procedures

1	General	286
	1.1 Application	
	1.2 General requirements	
	1.3 Welding personnel	
	1.4 Welding procedure specification	
	1.5 Parent metal	
	1.6 Welding consumables	
2	Welding procedure	287
	2.1 General	
	2.2 Assembly and welding	
3	Non-destructive examinations	287
	3.1 General	
	3.2 Visual examination	
	3.3 Radiographic examination	
	3.4 Ultrasonic examination	
	3.5 Magnetic particle	
4	Butt weld procedure test	287
	4.1 Assembly	
	4.2 Examinations and tests	
	4.3 Tensile tests	
	4.4 Bend tests	
	4.5 Impact tests	
	4.6 Hardness measurements	
	4.7 Metallographic examination	
5	Fillet weld procedure test	290
	5.1 Assembly	
	5.2 Examinations and tests	
6	Re-testing	291
	6.1 Non-destructive examinations	
	6.2 Destructive tests	
7	Range of approval	291
	7.1 Parent metal	
	7.2 Thickness	
	7.3 Edge preparation and surface condition	
	7.4 Joint type, bevel	
	7.5 Welding procedure	
	7.6 Welding parameters	

Section 6 Qualification Scheme for Welders of Hull Structural Steels

1	Scope	294
	1.1 Application	
2	General	294
	2.1	
3	Range of qualification of welders	294
	3.1 Application	

4	Qualification test	297
	4.1 General	
	4.2 Test assemblies	
	4.3 Examination and test	
	4.4 Retest	
5	Certification	299
	5.1	
6	Period of Validity	299
	6.1 Initial approval	
	6.2 Maintenance of the approval	

Part D
Materials and Welding

Chapter 1

GENERAL REQUIREMENTS

- SECTION 1 MANUFACTURE, INSPECTION, CERTIFICATION**
- SECTION 2 TESTING PROCEDURES FOR MATERIALS**
- APPENDIX 1 REQUIREMENTS FOR NDT SUPPLIERS**

SECTION 1

MANUFACTURE, INSPECTION, CERTIFICATION

1 General

1.1 Application

1.1.1 Part D specifies in Chapter 2 to Chapter 4 the requirements for the manufacture, inspection and certification of steel and iron products, non-ferrous metals, various finished products and equipment such as propellers, pressure bottles, anchors, chain cables, ropes and sidescuttles, entering in the construction or repair of ships which are surveyed for classification purposes.

The general requirements relevant to the manufacture, inspection and certification of the above-mentioned materials and products, hereafter generally referred to as "products", are given in this Chapter and are to be complied with as applicable.

The requirements of Chapter 1 are also applicable, as appropriate, to products covered by other parts of the Rules.

Part D specifies in Chapter 5 the requirements for approval of welding consumables and qualification of welding procedures.

1.1.2 In addition to Part D, the requirements given for certain materials, procedures and products in the other Parts of the Rules or specified on the approved plans, are also applicable, where appropriate.

1.1.3 Products subject to the requirements of Part D and the relevant testing operations are those laid down in the relevant Rules of the Society dealing with the design, inspection at works and testing of products, unless otherwise specified.

1.1.4 Products with properties departing appreciably from those covered by the Rules may be used with the approval of the Society

1.2 Other specifications

1.2.1 Products complying with international, national or proprietary specifications may be accepted by the Society, provided such specifications give reasonable equivalence to the requirements of these Rules or are approved for a specific application.

Such products, when accepted, are designated by their standard identification mark or as agreed at the time of the approval.

Unless otherwise agreed, inspection and certification of products complying with other specifications are to be carried out in accordance with the requirements of the Rules.

1.3 Information to be supplied by the purchaser

1.3.1 The purchaser is to provide the Manufacturer with the information necessary to ensure that products are tested in accordance with these Rules; optional or additional conditions are also to be clearly indicated.

2 Manufacture and quality

2.1 General

2.1.1 Manufacture

Manufacturers and their individual works are to be recognised by the Society for the type of products fabricated.

To this end plants, production and treatment procedures, testing machines, laboratories for analyses, internal control systems and personnel qualification are to be suitable in the opinion of the Society.

Manufacturing procedures and techniques are to be such as to reasonably ensure constant compliance of the product with the requirements.

Where tests and analyses are performed by external laboratories or third parties, these are to be recognised by the Society.

2.1.2 Approval

Depending on the type and importance of the products being supplied, the relevant manufacturing process may be required to be approved and approval tests performed for the purpose.

When approval of the manufacturing process is required, such condition is specified in the rule requirements relevant to the various products.

The provisions for the approval of Manufacturers are given in the "Rules for the approval of Manufacturers of materials".

2.1.3 Responsibility

Irrespective of the interventions of Surveyors, the Manufacturer is entirely and solely responsible for compliance of the supplied products with the stipulated requirements.

The Society assumes no liability by its testing interventions in respect of the compliance of a tested product with the stipulated regulations and requirements.

Where, in the course of manufacture or after supply, a product is found not to be in compliance with the requirements or to present unacceptable defects, it will be rejected, irrespective of any previous satisfactory test results.

2.2 Chemical composition

2.2.1 The chemical composition is to be determined and certified, as a rule, by the Manufacturer using ladle sampling analysis. The laboratory is to be adequately equipped and the analyses are to be performed by qualified personnel.

2.2.2 The analyses of the Manufacturer are generally accepted subject to occasional checks, if required by the Surveyor. When checks on the product are required, they are to be performed and the results evaluated in accordance with recognised standards.

2.3 Condition of supply

2.3.1 (1/7/2003)

Unless otherwise agreed, the products are to be supplied in the finished condition as per rules, including heat treatment if required.

Heat treatment is to be carried out in suitable and efficient furnaces, fitted with appropriate means for temperature control and recording.

The furnaces employed are to have a size sufficient to allow a uniform increase in temperature up to the required value of the whole furnace charge to be heat treated. In the case of very large parts, alternative systems proposed are to be agreed by the Society.

Sufficient thermocouples are to be connected to the furnace charge to measure and record its temperature and check that it is adequately uniform, unless the temperature uniformity of the furnace is verified at regular intervals.

2.4 Identification of products

2.4.1 In the course of manufacturing, inspection and testing, the identification of the various products in respect of their origin is to be ensured as required.

To this end the Surveyor is to be given all facilities for tracing the products when required.

3 Inspection and testing

3.1 General conditions

3.1.1 As a rule, the inspections and tests are to be carried out at the Manufacturer's works before delivery.

If the necessary facilities are not available at the Manufacturer's works, the testing is to be carried out at a recognised testing laboratory.

3.1.2 Where the testing is allowed to be carried out or completed at works other than the Manufacturer's it is in any case to be possible to trace back with certainty to the documentation of the origin.

3.1.3 Interested parties are to apply for inspection in adequate time.

Prior to the inspection and testing, the Manufacturer is to provide the Surveyor with details of the orders, technical specifications and any special condition additional to the rule requirements.

3.1.4 The Surveyors are to have free access to all departments involved in production, collection of test samples, internal control and, in general, all operations concerning the inspection.

They are to be supplied with the information necessary to assess whether production and tests are performed according to the rule requirements.

3.1.5 All tests and checks required by the Rules are to be carried out in the presence of the Surveyors or, when expressly agreed with the Society, in the presence of the person responsible for internal control, specially delegated for this purpose.

The inspection and testing activities may be delegated to the Manufacturer under the conditions given in [3.2].

3.1.6 The tests required are to be performed by qualified personnel in accordance with the procedures stated by the Society or, failing this, with recognised national or international standards.

The testing and measuring equipment is to be adequate, maintained in proper condition and regularly calibrated, as required; the record of such checks is to be kept up-to-date and made available to the Surveyor.

3.2 Alternative inspection scheme

3.2.1 Alternative procedures to the systematic intervention of the Surveyor for testing may be adopted by Manufacturers specially recognised by the Society for the purpose.

Such alternative inspection schemes, which are determined by taking into account the type of product, its mass production and the effectiveness of the certified Quality System implemented in the workshop, allow the testing operations indicated in these Rules to be totally or partially delegated to the Manufacturer.

Indications on the field of application of such schemes, along with conditions and procedures for their recognition, are given by the Society in a separate document.

3.3 Sampling for mechanical tests

3.3.1 The test samples are to be selected by the Surveyor or by a responsible person from the Manufacturer's staff, specially delegated, and are to be suitably marked for identification purposes.

3.3.2 The test samples are to be representative of the unit or lot of material which they are relevant to and are therefore also to have been subjected to the same heat treatment as the products except when a different procedure is agreed with the Society.

3.3.3 For the purpose of test sampling the following definitions apply:

- a) unit: single forging, casting, plate, tube or other single product
- b) rolled unit: product rolled from the same slab or billet or, when rolling proceeds directly from ingots, from the same ingot
- c) batch: number of similar units or rolled units presented as a group for acceptance testing, on the basis of the tests to be carried out on the test sample
- d) sample: a sufficient quantity of material taken from the unit, rolled unit or batch, for the purpose of producing one or more test specimens
- e) test specimens: part of sample with specified dimensions and conditions for submission to a given test.

3.4 Mechanical tests

3.4.1 The mechanical tests are to be carried out in the presence of the Surveyor unless otherwise agreed; see [3.2].

3.4.2 For the check of the mechanical properties of the material, test methods and specimens in compliance with the requirements of Sec 2 are to be used.

3.4.3 The type of tests, the number and direction of the test specimens and the results of the tests are to comply with the requirements relevant to the type of product, as indicated in the various Articles.

3.5 Re-test procedures

3.5.1 General

Where the unsuccessful outcome of any test is attributable to defective machining of the test specimen and/or to improper test procedure, the negative result is disregarded and the test repeated, in correct conditions, on a substitute test specimen.

Where a test, other than an impact test, gives a result which is not in compliance with the requirements, two additional tests may be allowed to be performed on specimens of the same type taken from the same samples. For the purpose of acceptance, both tests are to comply with the requirements.

For the impact test, performed on a set of three test specimens, where the average value of the set does not comply with the required value, provided that not more than two test results are less than such value, with not more than one less than 70% of it, a second test may be allowed to be performed on three test specimens of the same type taken from the same samples.

For acceptance, the new average, calculated on the basis of the six results of the first and second sets of three test specimens taken together, is to comply with the required value, not more than two individual values are to be lower than the required average and, of these, not more than one is to be less than 70% of it.

3.5.2 Rejection or reconsideration

Where unsatisfactory results are obtained from re-tests representative of one lot of material, the unit from which the test specimens are taken is rejected.

The remainder of the lot may, at the discretion of the Surveyor, be reconsidered by performing the required tests on at least two different units; for acceptance, both the results of the new tests are to satisfy the requirements.

Otherwise, upon agreement with the Surveyor, the individual units composing the lot may be tested individually and those found satisfactory may be accepted.

The Manufacturer may resubmit for testing previously rejected material, after a suitable heat treatment or reheat treatment, or resubmit it under a different grade.

The Surveyor is to be notified of such circumstances.

Unless otherwise agreed by the Surveyor, only one new heat treatment is permitted for material which has already been heat treated.

3.6 Visual and dimensional examinations and non-destructive tests

3.6.1 General

The products are to be subjected to:

- a) visual examination
- b) dimensional check
- c) non-destructive examination, when applicable.

The above operations, to be effected on products in appropriate conditions, are carried out under the responsibility of the Manufacturer and are to be witnessed or repeated in the presence of the Surveyor when required by the Rules or, in any case, when it is deemed necessary by the Surveyor.

When, following examinations and tests, there are grounds for thinking a product may be defective, the Manufacturer is obliged, for the purpose of acceptance, to demonstrate its suitability using procedures deemed necessary.

3.6.2 Visual examination

Visual examination, unless otherwise specified, is performed by the Surveyor on each unit, for products tested on individual units and, randomly or on the units submitted to mechanical tests, for products tested by lot.

3.6.3 Dimensional check

The dimensional checks and verification of compliance with approved plans are carried out by the Surveyor, as deemed necessary, solely for those parts subject to approval, or where expressly required in Part D or other parts of the Rules.

3.6.4 Non-destructive test (1/7/2020)

Non-destructive tests are to be performed according to the requirements in App 1.

The Manufacturer's laboratory or other organisation responsible for the non-destructive test is required to issue, on its own responsibility, a certificate reporting the results according to App 1, [2.10]; the certificate is to be countersigned by the Manufacturer.

For the radiographic test suitable means are to be provided in order to identify the zones examined and the relevant radiographic films.

The various steps of the examinations are to be witnessed by the Surveyor when required. In such case the certificates are generally to be countersigned by the witnessing Surveyor.

The radiographic examination is intended to be carried out by using X-ray. The use of gamma-ray may be accepted provided that it is demonstrated to the Society's satisfaction that this provides the same image quality as X-ray.

3.7 Repairs of defects

3.7.1 Small surface defects may be suitably removed by grinding or other appropriate means, provided that the dimensional tolerances, prescribed for the various products in the relevant Articles, are complied with.

The repaired zone is to be found free from defects and to be acceptable in the opinion of the Surveyor.

3.7.2 Repairs by welding may be accepted only where this is not in contrast with the requirements applicable to the product, and provided that they are deemed suitable in connection with the material, extent of defects and welding procedure.

The repair procedure is to be previously agreed upon with the Surveyor.

4 Identification and certification

4.1 Identification and marking

4.1.1 General

During the inspection, a detailed record of the products to be tested is to be submitted to the Surveyor with indication of the necessary data, as applicable:

- a) name of purchaser and order number
- b) hull number or destination
- c) number, size and mass of parts or batches
- d) cast number and chemical composition
- e) part reference number, detail of manufacturing process and heat treatment
- f) condition of supply.

4.1.2 Manufacturer's marking

Products, which have satisfactorily undergone the required inspection and tests are to be appropriately marked by the Manufacturer in at least one easily accessible location.

The marking is to contain all necessary indications, as specified in the Articles relevant to the various products, and is to correspond to the content of the inspection documentation.

The marks are to be stamped, as a rule, by means of brands, except when products could be impaired by such a system. When paints or other reliable alternatives are adopted, adequate duration of marking is to be ensured.

For small pieces contained in effective containers, as well as bars and sections of modest weight, adequately bound in

bundles, the marks are transferred to the container, label or top item of each bundle to the Surveyor's satisfaction.

4.1.3 Marking with the Society's brand

The products satisfactorily inspected in accordance with the Rules are to be marked with the Society's brand in the presence of the Surveyor unless otherwise agreed between Manufacturer and Surveyor.

All other additional marks required are specified in the applicable Articles depending on the products (e.g. name or initials of Manufacturer, material, grade and cast number, code for calendar year, running file number and code of the local office inspection, Surveyor's personal brand, TP as statement of hydrostatic test).

4.1.4 Society marking for incomplete inspection

Whenever a product is despatched for delivery or is to be marked without undergoing all the inspections and tests required (whether by the provisions of Part D or those of other parts of the Rules), the Society's brand will be replaced by the Society's mark for incomplete inspection.

The testing documents are to contain clear indications of all outstanding inspections and tests and specify the reason why they have not been performed.

Upon satisfactory completion of all required tests, the product is to be stamped with the Society's brand.

4.1.5 Invalidation of Society's brand

When a product already marked with one of the Society's stamps is found during or subsequent to the testing not to be in compliance with the requirements and is therefore rejected, the previously stamped marks are to be invalidated by punching them.

The Surveyors may request to check the invalidation effected.

Any repairs after the product is tested are subject to the prior consent of the Society; failing this, the validity of the original testing will automatically expire and the original testing marks are to be invalidated by the interested parties.

4.1.6 Society's brand for alternative inspection scheme

In the case of admission to an alternative inspection scheme, the marking with the Society's brand may be delegated to the Manufacturer, who will be supplied with the special brand to be used for this purpose.

4.2 Documentation and certification

4.2.1 Society's inspection certificate (1/7/2003)

For products tested with satisfactory results, the Society issues an inspection certificate signed by the Surveyor stating that the products have been tested in accordance with the Society's Rules.

This certificate is identified by the letter C for ease of reference in the various parts of the Rules.

An inspection certificate issued by the Manufacturer is to be attached to the Society's certificate and is to include, as applicable, the following particulars:

- a) Manufacturer's name
- b) purchaser's name, order number and hull number
- c) description of the product, dimensions and weight
- d) results of all specified inspections and tests, including non - destructive tests where applicable
- e) identification and testing marks stamped on the products.

In the case of testing of materials, the following particulars are also to be included:

- identification of specification or grade of material
- identification of the heat and relevant chemical analysis
- supply condition and the specification of heat treatment, if carried out, including temperature and holding time
- working and manufacturing procedure (for rolled products intended for hull, boilers and pressure vessels only)
- declaration that the material has been made by an approved process, as applicable, and that it has been subjected with satisfactory results to the tests required by the Rules.

By agreement with the Society, the inspection certificate issued by the Manufacturer may be directly confirmed by endorsement with the Society's brand and the signature of the Surveyor.

For products manufactured in large quantities and tested by heats or by lot, the Manufacturer is to further state, for the individual supplies, that the products have been produced according to the Society's Rules.

4.2.2 Society's inspection certificate for alternative inspection scheme

For products covered by the alternative inspection scheme, unless otherwise stated in the admission to the alternative inspection scheme, the Manufacturer is to issue a Certificate of Conformity on the appropriate Society form.

This certificate is identified by the letter CA (certificate for alternative survey) for ease of reference in the various parts of the Rules.

The inspection certificate issued by the Manufacturer and including all the information required in [4.2.1] is to be attached to the (CA) certificate.

The certificate is to be submitted to the Society for endorsement according to the procedures stated in the agreement for the alternative survey scheme.

4.2.3 Works' certificates

For products which in accordance with the relevant rules may be accepted only on the basis of a certificate of conformity issued by the Manufacturer, stating the results of the tests performed, such certificate is to contain the information required under [4.2.1], as applicable.

This certificate of conformity is identified by the letter W (works' certificate) for ease of reference in the various parts of the Rules.

For particular products it may be accepted that the tests or inspections are carried out by the Manufacturer not on the product supplied, but on the current production.

This particular certificate of conformity is identified by the letter R (report) for ease of reference in the various parts of the Rules.

SECTION 2

TESTING PROCEDURES FOR MATERIALS

1 General

1.1 Application

1.1.1 This Section specifies the requirements for testing procedures, testing machines and test specimens for mechanical and technological tests of materials.

The testing procedures and test specimens relevant to welding are specified in Chapter 5.

The Articles of the Rules, dealing with the various products, indicate the examinations and tests required together with the results to be obtained.

The general conditions specified in Sec 1 also apply.

1.2 Testing machines

1.2.1 (1/1/2023)

Testing machines are to be maintained in a satisfactory and accurate condition and calibrated by the Society, or by a recognised body in accordance with a recognised standard, at approximately annual intervals.

In particular:

- The accuracy of tensile test machines is to be within $\pm 1\%$ and when the calibration is in accordance with ISO 7500-1:2018 the permitted indication errors are to be within the specific values for Class 1.
- Impact testing machines are to be calibrated in accordance with ISO 148-2:2016 or other recognised standard.

The striking energy of the testing machine is to be not less than 150 J.

The records of the calibration are to be made available to the Surveyor and kept in the test laboratory.

1.3 Preparation of test specimens

1.3.1 The samples for test specimens are to be in the same condition as the product from which they have been taken and therefore in the same heat treatment condition, if any.

1.3.2 If the test samples are cut from products by flame cut, when admissible depending on the kind of material, or shearing, a reasonable margin is required to enable sufficient material to be removed from cut or sheared edges during final machining.

Test specimens are to be obtained from samples by mechanical cuts; care should be taken in their preparation to avoid any significant straining or heating which might alter the properties of the material.

2 Tensile test

2.1 Test specimens

2.1.1 Proportional flat specimen (1/7/2004)

For flat products, rectangular specimens of proportional type are generally used, having dimensions as shown in Fig 1.

Figure 1 : Proportional flat specimen (1/7/2004)

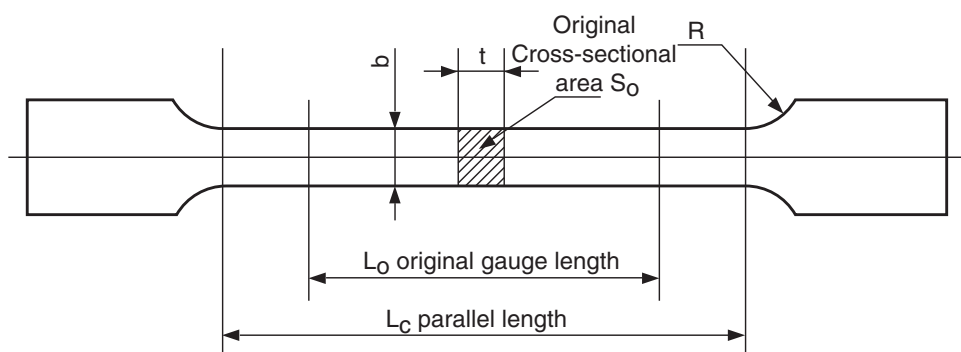

t : thickness of the considered material

b : 25 mm (width)

L_0 : $5,65S_0^{1/2}$ where S_0 is the specimen original cross sectional area. The gauge length may be rounded off the nearest 5 mm provided that the difference between the computed L_0 and that rounded length is less than 10% of L_0

L_c : $L_0 + 2S_0^{1/2}$

R : 25 mm (transition radius)

For such products the tensile test specimens are to retain the original raw surfaces of the product.

When the testing machine capacity does not allow testing of specimens of full thickness, this may be reduced by machining one of the raw surfaces.

2.1.2 Non-proportional flat specimen

As an alternative to the specimen mentioned above, non-proportional specimens may also be used; in particular a rectangular specimen, having fixed gauge length of 200 mm and other dimensions as shown in Fig 2, may be used.

2.1.3 Round specimen (1/7/2004)

As stated in [2.1.1], for rolled products, excluding bars, the tensile test specimens are to retain the original raw surfaces of the product.

However, for thickness equal to or greater than 40 mm, or, more generally, when the testing machine capacity does not allow testing of specimens of full thickness, a round proportional test specimen, machined to the dimensions shown in Fig 3, may also be used.

For long rolled products (bars and profiles), forgings and castings, grey cast iron excluded, cylindrical specimens of proportional type, having in general diameter of 10 or 14 mm, are to be used.

2.1.4 Round specimen diameter

The proportional round tensile specimens generally have diameter of 10 or 14 mm.

However others diameters, in general 8 or 6 mm, may be used in specific cases when the selection of normal size test specimens is not possible.

2.1.5 Round specimen position (1/7/2003)

In the case of rolled products (plates), with thickness equal to or greater than 40 mm, the axis of the round test specimen is to be located at approximately one quarter of the thickness from one of the rolled surfaces.

In the case of bars and similar products, the axis of the round test specimen is to be located at one third of the radius from the outside.

In the case of forged products, unless otherwise agreed, the longitudinal axis of test specimens is to be positioned as follows:

- for thickness or diameter up to maximum 50mm, the axis is to be at the mid-thickness or the centre of the cross section;
- for thickness or diameter greater than 50mm, the axis is to be at one quarter thickness (mid-radius) or 80mm, whichever is less, below any heat treated surface.

Figure 2 : Non proportional flat specimen (1/7/2004)

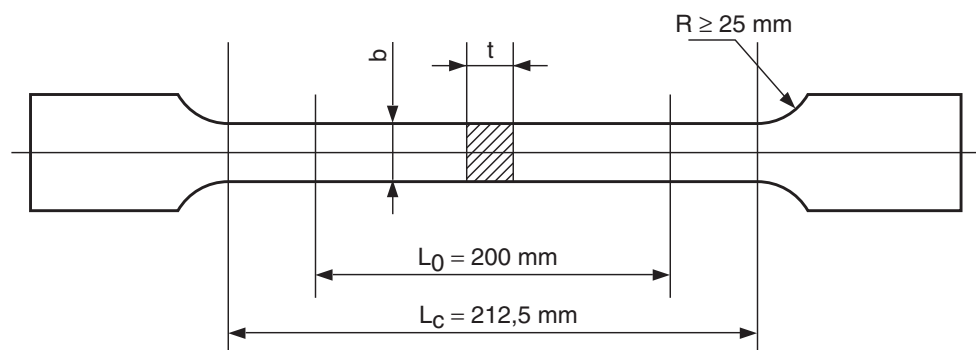

- t : thickness of the considered flat material
b : 25 mm

Figure 3 : Round proportional specimen (1/7/2004)

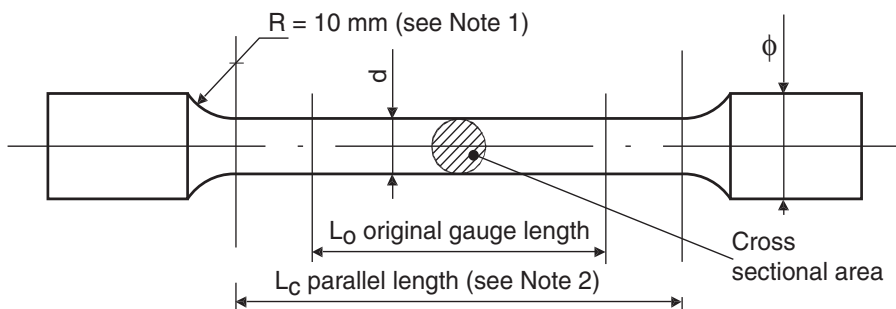

Note 1: $R \geq 1,5 d$ for nodular cast iron and materials with a specified elongation less than 10%

Note 2: $L_c = L_0 + d/2$

2.1.6 Specimen for grey cast iron

For grey cast iron, the test specimen as shown in Fig 4 is to be used.

Figure 4 : Specimen for grey cast iron

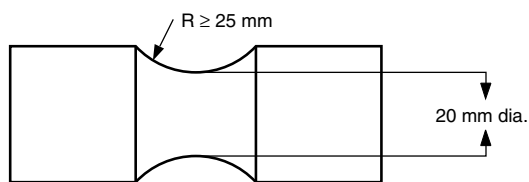

2.1.7 Specimens for pipes and tubes (1/10/2019)

For testing of pipes and tubes, the testing specimen may be a full cross-section of suitable length to be secured in the testing machine with plugged ends, as shown in Fig 5.

The gauge length L_0 is to be equal to:

$$L_0 = 5,65 \sqrt{S_0}$$

and the distance between the grips or between the plugs L_c is to be not less than the gauge length plus $D/2$, where D is the external diameter of the tube or pipe.

The length of the plugs projecting over the grips, in the direction of the gauge marks, is not to exceed the external diameter D , and the shape of the plugs is not to impede the elongation of the gauge length.

Figure 5 : Full cross section specimen

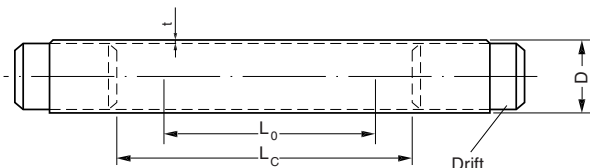

Alternatively test specimens are to be taken from the tube or pipe wall, as shown in Fig 6, where:

$$L_0 = 5,65 \sqrt{S_0}$$

$$L_c = L_0 + 2 b$$

The parallel test length is not to be flattened, but the enlarged ends may be flattened for gripping in the testing machine.

Figure 6 : Specimen taken from the tube or pipe wall

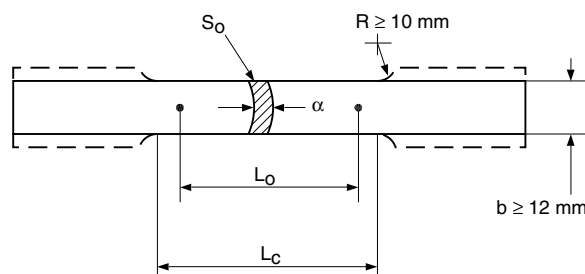

Where the wall thickness is sufficient to allow machining, the round specimen indicated in Fig 3 may be used, with the axis located at the mid-wall thickness.

2.1.8 Specimen for wires

For testing of wires, a full cross-section test specimen of suitable length is to be used.

The gauge length is to be 200 mm and the parallel test length (distance between the grips) is to be 250 mm.

2.1.9 Specimen for welding (1/10/2019)

For testing of welding, unless different requirements are given in Chapter 5, the specimens are to be prepared with the following dimensions.

a) Deposited metal tensile test

Round specimen with the following dimensions is to be used:

$d = 10 \text{ mm}$

$L_0 = 50 \text{ mm}$

$L_c > 55 \text{ mm}$

$R \geq 10 \text{ mm}$

For specially small or large dimensions other specimens may be used after agreement with the Society, provided they conform with the geometrical relationship given in Fig 3 for round proportional specimen.

b) Butt weld tensile test

Flat specimen with the dimensions according to Fig 7 is to be used.

The upper and lower surfaces of the weld are to be filed, ground or machined flush with the surface of the plate.

Figure 7 : Flat tensile test specimen (1/10/2019)

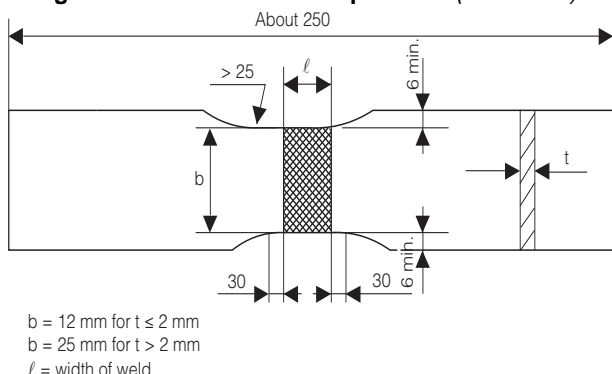

2.1.10 Dimensional tolerances (1/1/2023)

The dimensional tolerances of test specimens are to be in accordance with ISO 6892-1:2019, ISO 6892-2:2018 or other recognised standards as appropriate.

2.2 Testing procedure

2.2.1 General (1/7/2004)

The following characteristics, as required by the different products, are to be determined by the test:

- R_{eH} : Yield stress (yield point), in N/mm^2
- $R_{p0,2} - R_{p1,0}$: Proof stress (yield strength), in N/mm^2
- R_m : Tensile strength, in N/mm^2
- A: Percentage elongation at fracture
- Z: Percentage reduction of area.

2.2.2 Yield and proof stress determination (1/7/2004)

For materials with well defined yield phenomenon, the yield stress R_{eH} is the value corresponding to the first stop or drop of the index, showing the load applied by the testing machine in the tensile tests at ambient temperature.

This applies, unless otherwise specified, to products of carbon steels, carbon-manganese steels and alloy steels, except austenitic and duplex stainless steels.

For materials which do not present a manifest yield stress, as defined above, the 0,2% proof stress ($R_{p0,2}$) is to be determined according to the applicable specification, where 0,2 is the percentage of permanent deformation.

For austenitic and duplex stainless steel products and relevant welding consumables, the 1,0 per cent proof stress, designated by the symbol $R_{p1,0}$, may be required in addition.

2.2.3 Load application rate

The test is to be carried out with an elastic stress within the limits indicated in Tab 1.

After reaching the yield or proof load, for ductile material the machine speed during the tensile test is not to exceed that corresponding to a strain rate of $0,008\text{s}^{-1}$. For brittle materials, such as cast iron, the elastic stress rate is not to exceed 10 N/mm^2 per second.

Table 1 (1/7/2004)

Modulus of Elasticity of the material (E), in N/mm^2	Rate of stressing, in $\text{N/mm}^2 \text{ s}^{-1}$	
	Min.	Max.
$E < 150000$	2	20
$E \geq 150000$	6	60

2.2.4 Elongation (1/1/2023)

The per cent elongation is in general determined on a proportional gauge length L_0 .

L_0 is determined by the following formula:

$$L_0 = 5,65 \sqrt{S_0}$$

where:

S_0 : Original cross-sectional area of the test specimen.

In the case of round solid specimens, L_0 is 5 diameters.

The per cent elongation is also defined as short proportional elongation or A_5 .

When a gauge length other than L_0 is used, the equivalent per cent elongation A_x required is obtained from the following formula:

$$A_x : 2A_5 \left(\frac{\sqrt{S}}{L} \right)^{0,4}$$

where:

A_5 : Minimum elongation, in per cent, required by the Rules for the proportional specimens illustrated in Fig 1, Fig 3 and Fig 6

S : Area, in mm^2 , of the original cross-section of the actual test specimen

L : Length, in mm, of the corresponding gauge length actually used.

The above conversion formula may be used only for non-cold formed ferritic products with tensile strength not exceeding 700 N/mm^2 .

The extension of the formula to other applications, such as cold worked steels, austenitic steels or non-ferrous materials is to be agreed upon with the Society's Surveyors.

In the case of disagreement, the value of elongation computed on the proportional specimen is to be taken.

The gauge length to which the elongation is referred is to be indicated in the test reports.

For non-proportional test specimens with gauge length of 50 mm and 200 mm, the equivalent elongation values indicated in ISO 2566-1:1984; ISO 2566-2:1984 apply.

The elongation value is, in principle, valid only if the distance between the fracture and the nearest gauge mark is not less than one third of the original gauge length.

However, the result is valid irrespective of the location of the fracture if the percentage elongation after fracture is equal to or greater than the expected value.

The appearance of the fracture of test specimens after the tensile test is always to be examined. The appearance of the fracture section is to be sound and free from defects and irregularities.

2.2.5 Testing at elevated temperature

For testing at elevated temperature, the determination of 0,2 per cent proof stress is to have a gauge length for strain measurement not less than 50 mm and a cross-sectional area not less than 65 mm². However, if the dimensions of the product or the available test equipment do not allow such conditions, the largest possible dimension is to be used.

As yield stress the conventional value of 0,2 per cent proof stress is generally taken; the deformation rate immediately prior to reaching the yield stress is to be in the range between 0,1 and 0,3 per cent of the gauge length per minute.

The intervals between deformation measurements to assess the above-mentioned rate are not to exceed 6 seconds.

The equipment is to permit a test temperature control within a tolerance range $\pm 5^{\circ}\text{C}$.

2.2.6 Re-test procedure (1/7/2004)

When the tensile test fails to meet the requirements, two further tests may be made from the same piece.

If both of these additional tests are satisfactory, the item and/or batch (as applicable) is acceptable. If either or both of these tests fail, the item and/or batch is to be rejected.

The additional tests detailed above are preferably to be taken from material adjacent to that for the original tests, but alternatively from another test position or sample representative of the item/batch.

3 Bend test

3.1 Flat bend test specimen

3.1.1 A flat bend test specimen as shown in Fig 8 is to be used.

The edges on the tension side are to be rounded to a radius of 1 to 2 mm.

The length of the specimen is to be at least 11 times the thickness or 9 times the thickness plus the mandrel diameter, if this value is higher.

Figure 8 : Flat bend specimen

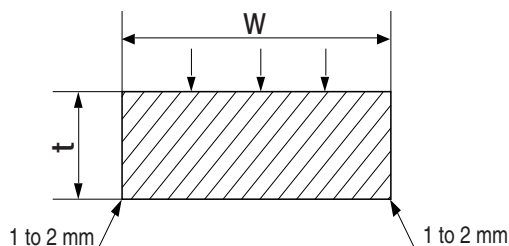

3.1.2 For castings, forgings, and half rough products, the other dimensions are to be as follows:

thickness: $t = 20 \text{ mm}$,

width: $w = 25 \text{ mm}$.

3.1.3 For rolled products the other dimensions are to be as follows:

thickness: $t = \text{thickness of product}$,

width: $w = 30 \text{ mm}$.

If the thickness of the rolled product is greater than 25 mm, the thickness of the specimen may be reduced to 25 mm by machining the surface of the specimen that is to be in compression during the test.

3.1.4 (1/10/2019)

For butt weld transverse specimen the other dimensions are to be as follows:

a) face and root bend

$t = \text{thickness of welded plate}$

$w = 30 \text{ mm}$

If the thickness of the rolled product is greater than 25 mm, the thickness of the specimen may be reduced to 25 mm by machining the surface of the specimen that is to be in compression during the test.

The surfaces of the weld are to be machined (ground) flush with the surface of the plate.

b) side bend

$t = 10 \text{ mm}$

$w = \text{thickness of the welded plate}$

If the thickness of the welded plate is equal or greater than 40 mm, the side-bend specimen may be subdivided, each part being at least 20 mm wide.

3.1.5 (1/10/2019)

Butt weld longitudinal specimens for longitudinal face and root bend test the specimen dimensions are to be in accordance with an appropriate recognised standard.

3.2 Testing procedure

3.2.1 The bend test is to be performed, as a rule, by applying a continuous mechanical compressive action on one of the surfaces of the test specimen.

The required mandrel diameter and the minimum bend angle are specified in the Articles dealing with the various products.

The test is satisfactory if the required bend angle is reached without incipient fracture.

4 Impact test

4.1 Sampling

4.1.1 (1/7/2004)

The impact test is, in general, to be determined on a set of 3 notched specimens.

The longitudinal axis of the notched test specimens can be:

- parallel to the rolling direction of the plate, of the section, or of the piece (longitudinal direction L)
- perpendicular to the rolling direction of the plate or of the piece (transverse direction T)
- parallel to other directions of selection.

The test specimens are to be of the V-notch type and are designated KV.

Depending on whether the Charpy test specimens have been taken in the lengthwise direction (L) or in the crosswise direction (T), the symbol L or T is added, respectively, to the Charpy designation.

4.1.2 The axis of the notch is to be perpendicular to the faces of the plate, section or piece.

The position of the notch is to be not nearer than 25 mm to a flame cut or sheared edge.

4.1.3 For rolled products, the impact test specimens are to be taken, in the case of thickness not higher than 40 mm, retaining the original raw surface of the product or within 2mm from it.

In the case of thickness higher than 40 mm, the test specimens are to be taken with their longitudinal axis located at a position lying 1/4 of the product thickness, or as near as possible to such position.

For forged products, the longitudinal axis of the specimens is to be located in the way of the external third of the distance between the centre (or the inside surface) of the piece and its external surface, considering a typical section of the forging.

4.2 Charpy V-notch specimens

4.2.1 The specimens are to be fully machined at the dimensions and tolerances shown in Fig 9 and Tab 2.

Figure 9 : Charpy V-notch specimen

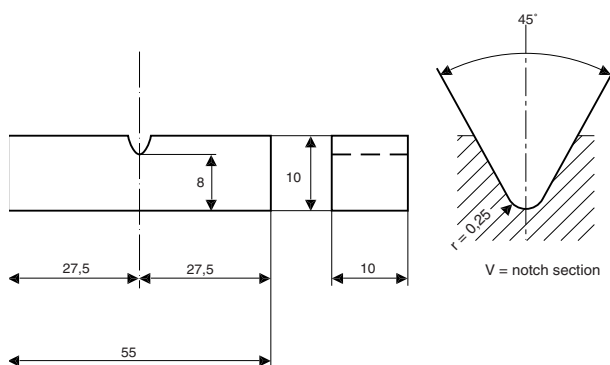

Table 2 : Charpy V-notch specimen

Dimensions	Nominal	Tolerance
Length	55 mm	$\pm 0,60$ mm
Width		
• standard specimen	10 mm	$\pm 0,11$ mm
• subsize specimen	7,5 mm	$\pm 0,11$ mm
• subsize specimen	5,0 mm	$\pm 0,06$ mm
Thickness	10 mm	$\pm 0,06$ mm
Depth below notch	8 mm	$\pm 0,06$ mm
Angle of notch	45 °	$\pm 2^\circ$
Root radius	0,25 mm	$\pm 0,025$ mm
Distance of notch from end of test specimen	27,5 mm	$\pm 0,42$ mm
Angle between plane of symmetry of notch and longitudinal axis of test specimen	90°	$\pm 2^\circ$

4.2.2 (1/7/2004)

Specimens with reduced sectional area 10x7,5 or 10x5 may be used when the product thickness does not permit machining of the standard size.

All other dimensions and tolerance are to be as specified in [4.2.1].

In all cases the largest size Charpy specimen possible for the material thickness is to be machined.

The required energy values are given in Tab 3.

4.3 Testing procedure

4.3.1 (1/7/2004)

Tests on V-notch type specimens are to be carried out at or below ambient temperature, in compliance with the requirements of the parts of the Rules relevant to the individual products and uses.

The term "ambient temperature" means any temperature within the range 18 to 28°C.

Where the test temperature is lower than ambient, the temperature of the specimen at the moment of the breaking is to be the specified test temperature, within plus minus 2°C.

The test temperature is to be clearly specified in the testing documents.

Table 3 : Average energy value for reduced specimens (1/7/2004)

Sectional area of V-notch specimens (mm ²)	Minimum average energy (1)
10 x 10	KV
10 x 7,5	5/6 KV
10 x 5	2/3 KV

(1) KV is the required average value on standard size specimens, as per the Rules.
Only one individual value may be below the specified average value, provided it is not less than 70% of such value.

4.3.2 For impact tests carried out on a set of three specimens, the Charpy impact toughness is the average adsorbed energy, expressed in Joule (J), resulting from the set.

The average of the results on the three specimens is to comply with the value required for the product in question, and one individual test result may be less than the required average value, provided that it is not less than 70% of it.

4.4 Re-test procedure

4.4.1 (1/7/2004)

Where specified the following Charpy re-test procedure will apply.

When the average value of the three initial Charpy V-notch impact specimens fails to meet the stated requirement, or the value for more than one specimen is below the required average value, or when the value of any one specimen is below 70% of the specified average value, three additional specimens from the same material may be tested and the results added to those previously obtained to form a new average. If this new average complies with the requirements and if not more than two individual results are lower than the required average and of these, not more than one result is below 70% of the specified average value, the piece or batch (as specified for each product) may be accepted.

5 Drop weight test

5.1 Definition and specimens dimensions

5.1.1 (1/1/2023)

The drop weight according to ASTM Standard E-208:2019 is used for determination of the NDT (nil ductility transition) temperature.

The NDT is the maximum temperature where the drop weight specimen breaks when tested according to the provisions of the standard.

Drop weight specimens have one of the following dimensions (thickness by width by length, in mm³):

- type P1: 25 x 90 x 360
- type P2: 19 x 50 x 130
- type P3: 16 x 50 x 130.

5.1.2 The following apply, if not otherwise agreed:

- the specimen sides are to be saw-cut or machined (minimum 25 mm distance to flame-cut surface)
- the machining of the sample to obtain the required thickness of the specimen is to be carried out only on one surface; the opposite mill scales surface is to be maintained
- the direction of the specimen in relation to the rolling direction is not important, but all the specimens of the same test series are to have the same orientation.

5.2 Testing procedure

5.2.1 Two test specimens are to be tested at the specified test temperature.

The compression side is to be on the machined side.

Both test specimens are to exhibit no-break performance at the specified temperature.

6 CTOD test (crack tip opening displacement test)

6.1

6.1.1 Unless otherwise agreed, the test is to be performed on specimens of full section thickness according to national or international standards.

Note 1: Internationally accepted standards include BS 7448 Part 1:1991 and ASTM E 1290 1989.

6.1.2 Other fracture mechanics tests intended to check the resistance to brittle fracture of the material may be carried out as required by the Society.

7 Ductility tests for pipes and tubes

7.1 Flattening test

7.1.1 (1/1/2023)

The specimen consists of a ring cut with the ends perpendicular to the axis of the pipe or tube.

The length of the specimen is to be from 10 mm to 100 mm.

Plain and smoothed ends cut perpendicular to the tube axis.

Reference is made to ISO 8492:2013.

7.1.2 The test consists of compressing the specimen between two rigid and parallel flat plates in a direction perpendicular to its longitudinal axis; the plates are to cover the whole specimen after flattening.

It is to be continued until the distance Z between the two plates, measured under load, reaches the value specified.

In the case of welded pipes or tubes, the test is to be carried out with the welded seam positioned at 90° and at 0° to the flattening force.

After flattening, the specimen is not to present any cracks or other flaws; however, small cracks at the ends may be disregarded.

7.2 Drift expanding test

7.2.1 (1/1/2023)

The specimen consists of a tube section having the ends perpendicular to the tube axis; the edges of the end to be tested may be rounded by filing.

Reference is made to ISO 8493:1998.

7.2.2 (1/7/2004)

For metallic tubes the length L of the specimen is to be equal to twice the external diameter D of the tube, if the angle of the drift β is 30° , or equal to $1,5 D$ if the angle of the drift is 45° or 60° .

The test piece may be shorter provided that after testing the remaining cylindrical portion is not less than $0,5 D$.

7.2.3 (1/7/2004)

The test consists of flaring the end of the specimen at ambient temperature and symmetrically, by means of a truncated-cone shaped mandrel of hardened steel having the included angle specified in [7.2.2] (Fig 10).

The mandrel is to be lubricated but is not to be rotated in the pipe during the test.

The mandrel penetration is to continue until the increase in external diameter of the end of the expanded zone reaches the value specified in the requirements relevant to the various products.

The rate of penetration of the mandrel is not to exceed 50 mm/min.

The expanded zone of the specimen is not to present any cracks or other flaws.

Figure 10 : Drift expanding test (1/7/2004)

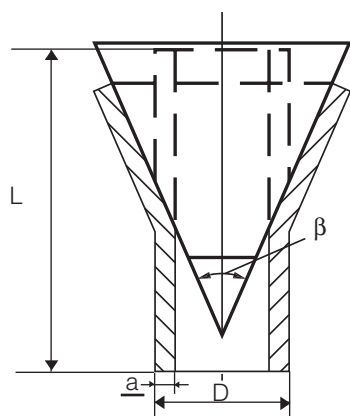

7.3 Flanging test

7.3.1 (1/1/2023)

The specimen consists of a tube section cut with the ends perpendicular to the tube axis and length at least equal to

approximately 1,5 times the external diameter D of the tube.

The test piece may be shorter provided that after testing the remaining cylindrical portion is not less than $0,5 D$.

The edges of the end to be tested may be rounded by filing.

Reference is made to ISO 8494:2013.

7.3.2 (1/7/2004)

The test is carried out in two stages and consists of symmetrically forming a flange at one end of the specimen by means of a special mandrel of hardened steel; the mandrel is to be lubricated but is not to be rotated in the tube during the test.

During the first stage of flanging, the end of the specimen is expanded by means of a truncated-cone shaped mandrel having an included angle of 90° ; the test is then continued during the second stage using a special forming mandrel to complete the flange.

The test is to be continued until the expanded zone forms a flange perpendicular to the longitudinal axis of the specimen, with an increase in the external diameter of the end of the specimen not less than the value specified (Fig 11).

The rate of penetration of the forming tool is not to exceed 50mm/min.

The cylindrical and flanged portion of the specimen is not to present any cracks or other flaws.

Figure 11 : Flanging test (1/7/2004)

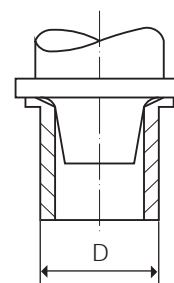

7.4 Ring expanding test

7.4.1 (1/1/2023)

The specimen consists of a tube section cut with the ends perpendicular to the tube axis and the length between 10 and 16mm.

Reference is made to ISO 8495:2013.

7.4.2 (1/7/2004)

The specimen is to be expanded to the prescribed diameter or until fracture occurs (Fig 12).

Figure 12 : Ring expanding test (1/7/2004)

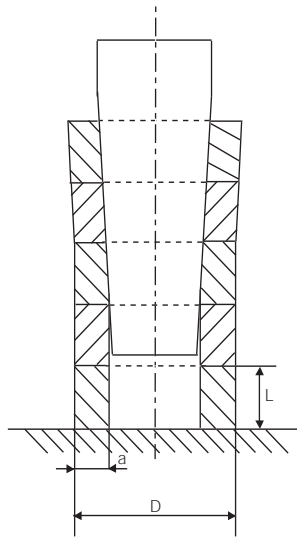

The rate of penetration of the mandrel is not to exceed 30mm/s.

The expanded specimen is not to reveal unacceptable defects such as cracks, grooves or laminations and is to reach the prescribed expansion.

7.5 Ring tensile test

7.5.1 (1/1/2023)

The specimen consists of a tube section with plain and smoothed ends cut perpendicular to the tube axis and with a length of about 15 mm.

Reference is made to ISO 8496:2013.

7.5.2 (1/7/2004)

The specimen is to be drawn to fracture in a tensile testing machine by means of two mandrels having diameter equal to at least three times the wall thickness of the pipe.

The rate is not to exceed 5mm/s.

In the case of welded pipes the weld seam is to be at 90° to the direction of the tensile load.

The specimen after fracture is not to reveal unacceptable defects such as cracks, grooves or laminations and is to show visible deformation at the point of fracture.

7.6 Bend test on pipes and tubes

7.6.1 Where feasible, the test specimen consists of full thickness strips not less than 40 mm in width (which may be machined down to 20 mm width for large thickness pipes) cut perpendicular to the pipe axis.

The edges of the specimen may be rounded to 1,5 mm radius.

The result is considered satisfactory if, after being bent through the required angle in the direction of the original

curvature, the specimen is free from cracks and laminations; however, small cracks on the edges may be disregarded.

7.6.2 For small diameter tubes, in general not exceeding 50 mm, the specimen consists of a tube section of sufficient length.

The specimen is to be bent on a cylindrical mandrel with appropriate procedures as follows, depending on the specification of the product:

- on a mandrel having a diameter 12 times the nominal diameter of the tube until an angle of 90° is reached
- on a mandrel having a diameter 8 times the nominal diameter of the tube, until an angle of 180° is reached.

The specimen after bending is not to present any cracks or other flaws.

8 Other tests and checks

8.1 Strain age embrittlement test

8.1.1 The test is performed according to the following requirements:

- the material is to be deformed, generally by compression (in special cases, deformation under tension may be permitted) until the required shortening (or elongation) (usually 3%, 5% or 10%) is attained
- the material is then to be heat treated in a furnace at 250°C for 1/2 h unless otherwise required
- Charpy impact specimens are to be obtained from the strained and treated material and broken at the specified temperature.

When the deformation is attained by lateral compression, the procedure of artificial aging described above may be applied directly to the individual test specimens.

8.2 Macrographic and micrographic examinations

8.2.1 The following examinations may be required to be performed as a random check for specific steel products:

- macrographic examination for detection of sulphur segregations (sulphur print or "Baumann test") according to ISO 4968
- evaluation of the primary austenitic grain size "McQuaid Ehn test" according to ASTM E 112 58 T Standards. For fine grained steels, the "fine grain" condition is considered satisfied when the grain size is 5 or finer.

Test methods according to other recognised standards are accepted.

8.2.2 The laboratory which carries out the examination is to issue a certificate of the results and photographic documentation of typical zones is to be enclosed.

APPENDIX 1

REQUIREMENTS FOR NDT SUPPLIERS

1 General

1.1 Scope

1.1.1 (1/7/2020)

Firms providing NDT (Non-Destructive Testing) services on ship and offshore structures/components subject to classification, need to fulfil the requirements set out in this Appendix. In this Appendix, such firms will be referred to as the Supplier.

1.2 Objective

1.2.1 (1/7/2020)

The objective of this Appendix is to ensure that the Supplier is using appropriate procedures, has qualified and certified personnel and has implemented written procedures for training, experience, education, examination, certification, performance, application, control, verification and reporting of NDT. In addition, the Supplier is to furnish appropriate equipment and facilities commensurate with providing a professional service.

1.3 Terms and definitions

1.3.1 (1/7/2020)

The following terms and definitions apply for this Appendix.

NDT: Non-destructive testing. Comprising, but not limited to the methods and techniques MT, PT, RT, RT-D, VT, UT, PAUT, TOFD, ET and/or ACFM

Supplier: Independent NDT company or NDT department/section that forms a part of a company providing NDT services on ship and/or offshore components/structures.

MT: Magnetic Particle Testing

PT: Penetrant Testing

RT: Radiographic Testing

RT-D: Digital Radiography (Several techniques within the method RT, e.g. Computed Radiography or Direct Radiography).

UT: Ultrasonic Testing

PAUT: Phased Array Ultrasonic Testing (Technique within the method UT).

TOFD: Time of Flight Diffraction (Technique within the method UT).

ET: Electromagnetic Testing (i.e. Eddy Current Testing and/or Alternating Current Field Measurements [ACFM])

VT: Visual Testing

Industrial sector: Section of industry or technology where specialised NDT practices are used, requiring specific product-related knowledge, skill, equipment and/or training.

1.4 References

1.4.1 (1/7/2020)

The following referenced documents are to be used for the application of this Appendix as appropriate. For undated references, the latest edition of the referenced document (including any amendments) applies.

- ISO 9712:2012; Non-destructive testing - Qualification and certification of NDT personnel

- ISO/IEC 17020:2012; Conformity assessment – Requirements for the operation of various types of bodies performing inspection

- ISO/IEC 17024:2012; Conformity assessment - General requirements for bodies operating certification of persons

- ISO 9001:2015; Quality Management Systems – Requirements

Other national adoptions of the standards listed above are accepted as compliant and hence are accepted for use together with this Appendix.

2 Requirements

2.1 Requirements for Supplier

2.1.1 (1/7/2020)

The Supplier is to document, as required in [2.3] to [2.10], that it has the competence and control needed to perform the specified services.

2.2 Requirements for documents

2.2.1 (1/7/2020)

The following documents are to be available for the Society upon request:

- an outline of Supplier's organisation and management structure, including any subsidiaries

- information on the structure of the Supplier's Quality Management System

- quality manual and documented procedures covering the requirements given in [2.3]- for companies with in-house certification of persons scheme; a written practice developed in accordance with a recognised standard or recommended practice (i.e. ASNT's SNT-TC-1A, 2016, ANSI/ASNT CP-189, 2016 or similar).

- operational work procedures for each NDT method including selection of the NDT technique.

- training and follow-up programmes for NDT operators including practical training on various ship and offshore products

- procedure for supervisor's authorisation of NDT operators

- experience of the Supplier in the specific service area,

- a list of documented training and experience for NDT operators within the relevant service area, including qualifi-

cations and third party certification per ISO 9712:2012 based certification schemes.

- description of equipment(s) used for the services performed by the Supplier
- a guide for NDT operators to use equipment mentioned above
- record formats for recording results of the services referred to in item [2.10]- information on other activities which may present a Conflict of interest
- record of customer claims and corrective actions
- any legal proceedings against the company in the past/currently in the courts of law

2.3 Quality management system

2.3.1 (1/7/2020)

The Supplier is to have a documented quality management system, covering at least:

- work procedures for all tasks and operations, including the various NDT methods and NDT techniques for which the Supplier is involved.
- preparation, issuance, maintenance and control of documents
- maintenance and calibration of the equipment
- training programs for the NDT operators and the supervisors
- maintenance of records for NDT operators' and the supervisors' training, qualification and certification
- certification of NDT operators including re-validation and recertification
- procedure for test of operators' visual acuity
- supervision and verification of operation to ensure compliance with the NDT procedures
- quality management of subsidiaries
- job preparation
- order reference system where each engagement is traceable to when, who and where the test was carried out.
- recording and reporting of information, including retention time of records
- code of conduct for the Supplier's activities; especially the NDT activities
- periodic review of work process procedures
- corrective and preventive action
- feedback and continuous improvement
- internal audits
- the provision of accessibility to required codes, standards and procedures to assist NDT operators.

A documented quality system complying with the most current version of ISO/IEC 17020:2012 and including the above would be considered acceptable. The Supplier should satisfy the requirements of Type A or Type B inspection body, as described in ISO/IEC 17020:2012.

2.4 Qualification and certification of NDT personnel

2.4.1 (1/7/2020)

The Supplier is responsible for the qualification and preferably 3rd party certification of its supervisors and operators to a recognised certification scheme based on ISO 9712:2012.

Personnel qualification to an employer based qualification scheme as e.g. SNT-TC-1A, 2016 or ANSI/ASNT CP-189, 2016 may be accepted if the Supplier's written practice is reviewed and found acceptable by the Society. The Supplier's written practice is to as a minimum, except for the impartiality requirements of a certification body and/or authorised body, comply with ISO 9712:2012.

The supervisors' and operators' certificates and competence are to comprise all industrial sectors and techniques being applied by the Supplier.

Level 3 personnel is to be certified by an accredited certification body.

2.5 Supervisor

2.5.1 (1/7/2020)

The Supplier is to have a supervisor or supervisors, responsible for the appropriate execution of NDT operations and for the professional standard of the operators and their equipment, including the professional administration of the working procedures. The supplier is to employ, on a full-time basis, at least one supervisor independently certified to Level 3 in the method(s) concerned as per the requirements of item [2.4]. It is not permissible to appoint Level 3 personnel; they must be certified by an accredited certification body. It is recognised that a Supplier may not directly employ a Level 3 in all the stated methods practiced. In such cases, it is permissible to employ an external, independently certified, Level 3 in those methods not held by the full-time Level 3(s) of the Supplier.

The supervisor is to be directly involved in review and acceptance of NDT Procedures, NDT reports, calibration of NDT equipment and tools. The supervisor is to on behalf of the Supplier re-evaluate the qualification of the operators annually.

2.6 Operators

2.6.1 (1/7/2020)

The operator carrying out the NDT and interpreting indications, is to as a minimum, be qualified and certified to Level 2 in the NDT method(s) concerned and as described in [2.4].

However, operators only undertaking the gathering of data using any NDT method and not performing data interpretation or data analysis may be qualified and certified as appropriate, at level 1.

The operator is to have adequate knowledge of materials, weld, structures or components, NDT equipment and limitations that are sufficient to apply the relevant NDT method for each application appropriately.

2.7 Equipment

2.7.1 (1/7/2020)

The Supplier is to maintain records of the NDT equipment used and detail information related to maintenance, calibration and verification activities. If the Supplier hires equipment, such equipment is to have updated calibration records, and the operators are to be familiar with the specific equipment type prior to using it. Under any circumstance, the Supplier is to possess sufficient equipment to carry out the services being a part of the NDT scope required by the Society. Where the equipment is of unique nature, the NDT operators are to be trained by competent

personnel in the operation and use of the equipment before carrying out NDT using this equipment.

2.8 Work instructions and procedures

2.8.1 (1/7/2020)

The Supplier is to produce written procedures for the NDT being applied. These procedures are to be written, verified or approved by the Supplier's Level 3. Procedures are to define all relevant information relating to the inspection including defect evaluation against acceptance criteria in accordance with the applicable Rules' requirements. All NDT procedures and instructions are to be properly documented in such a way that the performed testing can be eas-

ily retraced and/or repeated at a later stage. All NDT procedures are to be acceptable to the Society.

2.9 Sub-contractors

2.9.1 (1/7/2020)

The Supplier is to give information of agreements and arrangements if any part(s) of the services provided are sub-contracted. The Supplier, in the following-up of sub-contracts is to give emphasis to the quality management system of the subcontractor.

Subcontractors are to meet the same requirements placed on Suppliers for any NDT performed.

2.10 Reporting

2.10.1 (1/7/2020)

All NDT are to be properly documented in such a way that the performed testing and examination can be easily retraced and/or repeated at a later stage. The reports are to identify the defects present in the tested area, and a conclusive statement as to whether the material, weld, component or structure satisfies the acceptance criteria or not.

The report is to include a reference to the applicable standard, NDT procedure and acceptance criteria applied in the applicable NDT method/technique. In general, the acceptance criteria are to comply with the applicable Rules' requirements.

STEEL AND IRON PRODUCTS

SECTION 1	ROLLED STEEL PLATES, SECTIONS AND BARS
SECTION 2	STEEL PIPES, TUBES AND FITTINGS
SECTION 3	STEEL FORGINGS
SECTION 4	STEEL CASTINGS
SECTION 5	IRON CASTINGS
APPENDIX 1	MEASURES FOR EXTREMELY THICK STEEL PLATES
APPENDIX 2	ESSO TEST
APPENDIX 3	ADDITIONAL APPROVAL PROCEDURE FOR CORROSION RESISTANT STEEL
APPENDIX 4	TEST METHOD FOR BRITTLE CRACK ARREST TOUGHNESS, KCA
APPENDIX 5	OUTLINE OF REQUIREMENTS FOR UNDERTAKING ISOTHERMAL CRACK ARREST TEMPERATURE (CAT) TEST
APPENDIX 6	MATERIAL AND WELDING FOR THE STORAGE AND TRANSPORT OF LIQUEFIED GASES IN BULK AND FOR THE USE OF GASES OR OTHER LOW-FLASHPOINT FUELS

SECTION 1

ROLLED STEEL PLATES, SECTIONS AND BARS

1 General

1.1 Application

1.1.1 General (1/7/2022)

The requirements of this Section apply to hot rolled plates, strips, sections and bars intended for hull, structural applications, boilers, pressure vessels and parts of machinery.

Article [1] specifies the requirements common to all the above-mentioned steel products, while the appropriate specific requirements are indicated in Articles [2] to [9].

In the case of applications involving the storage and transport of liquefied gases in bulk and the use of gases or other low-flashpoint fuels, the additional requirements in App 6 apply.

1.1.2 Weldability

Steels in accordance with these Rules are weldable subject to the use of suitable welding processes and, where appropriate, to any conditions stated at the time of approval.

1.1.3 Products with through thickness properties

For products intended for welded construction which may be subject to particular stress in the thickness direction, it is suggested, and may be required, that the material satisfies the through thickness properties indicated in Article [9].

For steels specified in Article [9], a further symbol Z is to be added to the steel designation.

1.2 Manufacture

1.2.1 Steel is to be manufactured by the electric furnace, basic oxygen or open hearth processes.

The use of other processes may be specially approved by the Society.

1.2.2 The steel is to be cast in ingot moulds or by a continuous casting process.

Provision is to be made for sufficient discard such as to ensure:

- at both ends of the ingots, the soundness of the material
- at the transitory zones of continuous casting material, a homogeneous chemical composition along the longitudinal axis.

1.3 Approval

1.3.1 (1/1/2001)

The manufacturing process is to be approved by the Society for individual steelmakers, grade of steel and products, as specified in the applicable Articles.

The suitability of each grade of steel for forming and welding is to be demonstrated during the initial approval tests at the steelworks. Approval of the steel works is to follow a scheme accepted by the Society.

Provisions for the approval are given in the "Rules for the approval of Manufacturers of materials".

1.4 Quality of materials

1.4.1 All products are to have a workmanlike finish and to be free from surface or internal defects which may impair their proper workability and use.

1.4.2 (1/7/2011)

The responsibility for storage and maintenance of the delivered product(s) with acceptable level of surface conditions rests with the shipyard before the products are used in fabrication.

1.5 Visual, dimensional and non-destructive examinations

1.5.1 Visual, dimensional and, as appropriate, non-destructive examinations are to be performed by the Manufacturer on the materials supplied prior to delivery, as required.

The general provisions indicated in Ch 1, Sec 1, [3.6] and specific requirements for the various products as specified in the relevant Articles of this Section apply.

In the case of doubt about defects [1.4.1], suitable methods of non-destructive examinations may be required by the Surveyor.

1.5.2 (1/7/2011)

The thickness of the plates and strips is to be measured at locations of a product or products as defined in the Articles relevant to the various products. In any case, the distance of the locations from the transverse or longitudinal edges of the product is to be not less than 10 mm.

Automated method or manual method is applied to the thickness measurements.

The procedure and the records of measurements are to be made available to the Surveyor and copies provided on request.

The tolerances on nominal thickness are indicated in the Articles relevant to the various products.

The tolerances on nominal thickness are not applicable to areas repaired by grinding, which are to be in accordance with a recognised standard.

The responsibility for verification and maintenance of the production within the required tolerances rests with the Manufacturer. The Surveyor may require to witness some measurements.

1.6 Rectification of surface defects

1.6.1 Rectification of surface defects by grinding

Defects which need to be repaired may be removed by grinding.

The general provisions of Ch 1, Sec 1 and specific requirements for the various products as specified in the relevant Articles of this Section apply.

The repaired areas are to be ground smooth to the adjacent surface of the plate.

The Surveyor may request that the complete removal of defects is verified by suitable non-destructive examination.

1.6.2 Rectification of surface defects by welding

Surface defects of products which cannot be removed as stated in [1.6.1] may be repaired by chipping or grinding followed by welding subject to the Surveyor's consent and under his supervision.

The general provisions of Ch 1, Sec 1 and specific requirements for the various products as specified in the relevant Articles of this Section apply.

1.7 Condition of supply

1.7.1 The conditions of supply are specified in the Articles relevant to the various products.

Where alternative supply conditions are agreed, the choice of the supply condition, unless otherwise required, is left to the Manufacturer; the condition of supply is always to be mentioned in the testing documentation.

1.7.2 When acceptable as an alternative to normalising, the procedures relevant to controlled or thermo-mechanical rolling process are to be specially approved for individual steelworks.

1.7.3 (1/7/2018)

The following definitions apply to the condition of supply:

a) As Rolled, AR

This procedure involves steel being cooled as it is rolled with no further heat treatment. The rolling and finishing temperatures are typically in the austenite recrystallization region and above the normalising temperature. The strength and toughness properties of steel produced by this process are generally less than steel heat treated after rolling or than steel produced by advanced processes.

b) Normalising, N

Normalising involves heating rolled steel above the critical temperature, A_{c3} , and in the lower end of the austenite recrystallization region for a specific period of time, followed by air cooling. The process improves the

mechanical properties of as rolled steel by refining the grain size and homogenising the microstructure.

c) Controlled Rolling (CR) or Normalising Rolling (NR): Rolling procedure in which the final deformation is carried out in the normalising temperature range, allowed to cool in air, resulting in a material condition generally equivalent to that obtained by normalising.

d) Quenching and Tempering, QT

Quenching involves a heat treatment process in which steel is heated to an appropriate temperature above the A_{c3} , held for a specific period of time, and then cooled with an appropriate coolant for the purpose of hardening the microstructure. Tempering subsequent to quenching is a process in which the steel is reheated to an appropriate temperature not higher than the A_{c1} , maintained at that temperature for a specific period of time to restore toughness properties by improving the microstructure and reduce the residual stress caused by the quenching process.

e) Thermo-Mechanical Rolling, TM (Thermo-Mechanical Controlled Processing, TMCP) procedure, which involves the strict control of both the steel temperature and the rolling reduction. Generally, a high proportion of the rolling reduction is carried out close to the A_{r3} transition temperature and may involve the rolling in the dual phase (austenite + ferrite) zone. Unlike controlled rolling (normalising rolling), the properties conferred by thermo-mechanical rolling (TM, TMCP) cannot be reproduced by subsequent normalising or other heat treatment.

f) Accelerated cooling (A_cC): rolling procedure with the use of accelerated cooling on completion of rolling (TM) which aims to improve the mechanical properties by controlled cooling, with rates higher than air cooling, immediately after the last rolling pass. The properties conferred by TM and A_cC cannot be reproduced by subsequent normalising or other heat treatment.

Direct quenching is excluded from accelerated cooling.

Where NR (CR) and TM with/without A_cC are applied, the programmed rolling schedules are to be verified by the Society at the time of the steelworks approval, and are to be made available when required by the attending Surveyor. On the Manufacturer's responsibility, the programmed rolling schedules are to be adhered to during the rolling operation (see [2.3.1]). In this regard, the actual rolling records are to be reviewed by the Manufacturer and occasionally by the Surveyor.

When deviation from the programmed rolling schedules or normalising or quenching and tempering procedures occurs, the Manufacturer is to take further measures as required above, to the Surveyor's satisfaction.

Figure 1 : Schematic Diagrams of Thermo-Mechanical and Conventional Processes (1/7/2018)

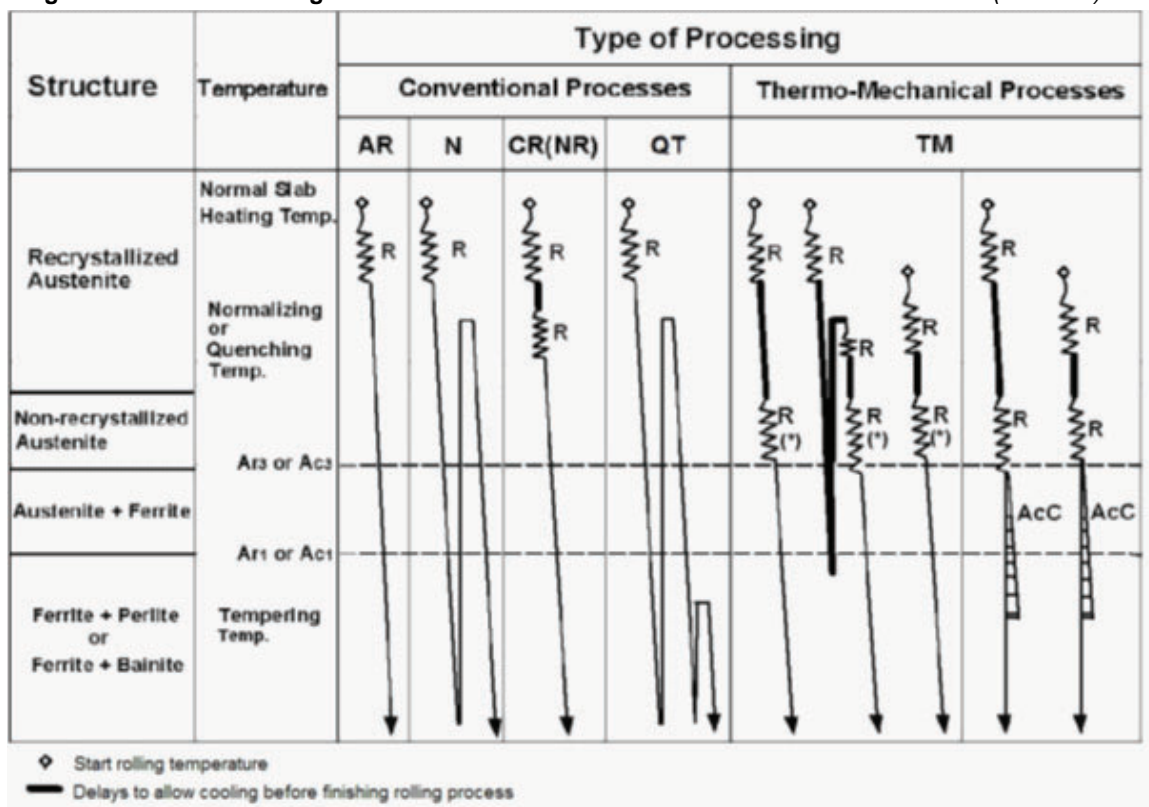

Notes:

AR: As Rolled

N: Normalizing

CR(NR): Controlled Rolling (Normalizing Rolling)

QT: Quenching and Tempering

TM: Thermo-Mechanical Rolling (Thermo-Mechanical Controlled Process)

R: Reduction

(*): Sometimes rolling in the dual-phase temperature region of austenite and ferrite

AcC: Accelerated Cooling

1.8 Sampling and tests

1.8.1 General

All products are to be presented for testing in the final supply condition in batches or rolled units as specified in the Articles relevant to the various products.

1.8.2 Sampling

The samples required for the preparation of test specimens are, in general, to be cut from:

- the end of the plate or section corresponding to the top position of the ingot, in the case of casting in ingot moulds
- any end of the plate or section, where such products are rolled from blooms or billets manufactured by continuous casting, on the understanding that sufficient discard is taken from the transitory zones of the cast beginning and end
- both the ends of the coil for plates fabricated in coils.

Samples are to be taken from the following positions:

- plates and flats having width ≥ 600 mm: at approximately one quarter of the width from an edge (see Fig 2)
- flats having width < 600 mm, bulb flats and sections: at approximately 1/3 of the width from an edge (see Fig 3, Fig 4 and Fig 5); alternatively, for channels, beams or bulb angles: on the web, at approximately 1/4 of the width from the centreline (see Fig 5)
- hollow sections: if rectangular, at approximately in the centreline of one side; if circular, at any position along the circumference
- bars: at approximately 1/3 of the radius or half-diagonal from the outer surface; the axis of the sample should be at least 12 mm from the outer surface, except for bars having diameter 25 mm or less, in which case the sample is to be concentric with the bar (see Fig 6).

Figure 2 : Plates and flats

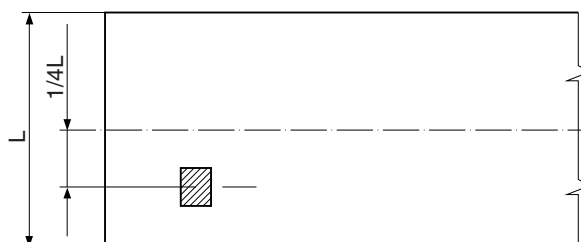

Figure 3 : Bulb flats

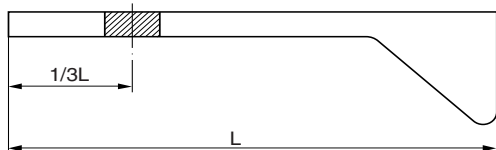

Figure 4 : Angles

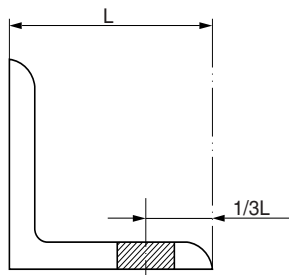
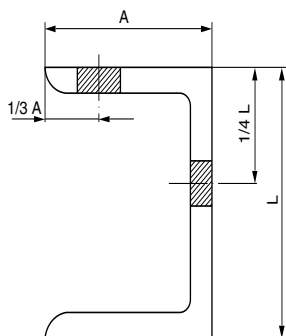

Figure 5 : Sections



1.8.3 Preparation of test specimens

The test specimens are to be cut from the samples with their principal axis parallel (longitudinal test) or perpendicular (transverse test) to the direction of rolling, as required in the Articles relevant to the various products.

For the preparation of test specimens and for the testing procedures, reference is to be made to the applicable requirements of Ch 1, Sec 2.

1.8.4 Tensile test

The results of the test are to comply with the values specified in the Tables relevant to the various products.

If during the tensile test there is no marked yield stress R_{eH} , the 0,2% proof stress $R_{p0,2}$, may be taken as an alternative.

Figure 6 : Bars

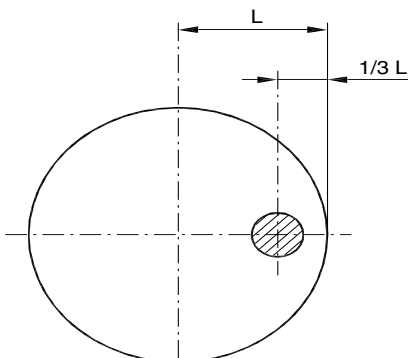

1.8.5 Impact test

The average value is to comply with the minimum average value specified in the Tables relevant to the various products and only one individual value may be less than the average required, provided that it is not less than 70% of it.

The minimum average values are relevant to the standard specimen 10x10 mm².

For subsize specimen dimensions and requirements, reference is to be made to Ch 1, Sec 2, [4.2.2].

1.8.6 Re-test procedures

For re-test procedures, reference is to be made to Ch 1, Sec 1, [3.5].

1.9 Identification and marking

1.9.1 The Manufacturer is to adopt a suitable system of identification which enables the product to be traced to its original cast.

1.9.2 (1/7/2015)

All products which have been tested with satisfactory results are to be identified and marked, in addition to the Society's brand required in Ch 1, Sec 1, [4.1.3], with the following indications:

- a) Unified identification mark for the steel grade (e.g. A, A36).
- b) Steels which have been specially approved by the Society and which differ from these requirements are to have the letter "S" after the above identification mark (e.g. A36S, ES).
- c) When required by the Society, material supplied in the thermo-mechanically controlled process condition is to have the letters TM added after the identification mark (e.g. E36 TM).
- d) Name or initials to identify the steelworks.
- e) Cast number or other marking, which will enable the history of the fabrication of the product to be traced.
- f) If required by the purchaser, his order number or other identification mark.

Different marking systems are to be agreed with the Society.

1.9.3 (1/7/2015)

Steel plates that have complied with the requirements for corrosion resistant steel will be identified by adding a corrosion designation to the unified identification mark for the grade of steel.

The corrosion resistant steel is to be designated according to its area of application as follows:

- Lower surface of strength deck and surrounding structures; RCU
- Upper surface of inner bottom plating and surrounding structures; RCB
- For both strength deck and inner bottom plating; RCW

Example of designation: A36 TM RCB Z35.

1.10 Documentation and certification

1.10.1 Information required (1/7/2015)

The testing documentation indicated in Ch 1, Sec 1, [4.2.1] is required and is to contain all the appropriate information, including at least the following particulars:

- Purchaser's order number and if known the hull number for which the material is intended.
- Identification of the cast and piece including, where appropriate, the test specimen number.
- Identification of the steelworks.
- Identification of the grade of steel.
- Ladle analysis (for elements specified in Tab 1 and Tab 2), including the content of refining and alloying elements as applicable.
- For steel with a corrosion resistant steel designation, the weight percentage of each element added or intentionally controlled to improve corrosion resistance.
- Condition of supply when other than as rolled i.e. normalised, controlled rolled or thermo-mechanically rolled.
- State if rimming steel has been supplied for grade A sections, up to 12,5 mm thick.
- Test Results.

When a limit of C_{EO} is prescribed, the content of alloying elements may be omitted unless otherwise required.

1.10.2 Inspection certificate

Before signing the Society's inspection certificate or endorsing the inspection certificate issued by the Manufacturer (mill sheets), the Surveyor is to be provided by the Manufacturer with a written declaration, stating that the material has been manufactured by a process accepted by the Society, complies with the applicable requirements and has been satisfactorily tested in accordance with the Rules.

The following wording may be acceptable, either printed or stamped on the delivery documents, with the name of the steel Manufacturer and signed by one of his authorised representatives: "We hereby certify that the material has been made by an approved process and has been satisfactorily tested in accordance with the Society's Rules".

1.10.3 Casting and rolling in different works

When the steel is rolled, heat treated, etc., in a workshop other than that where it is originally cast, the Surveyor is to be supplied with the steelmaker's certificate stating the manufacturing process, the type of steel, the identification of the cast and the ladle analysis.

The workshop where the steel was produced is to be approved by the Society.

The Society's Surveyors are to have free access to the workshop of the original Manufacturer, who is fully responsible for complying with all applicable requirements.

2 Normal and higher strength steels for hull and other structural applications

2.1 Application

2.1.1 The requirements of this Article apply to weldable normal and higher strength steel hot rolled plates, wide flats, sections and bars intended for use in hull construction and other structural applications.

2.1.2 (1/7/2015)

Provision is made for:

- plates and wide flats of all grades not exceeding 100 mm in thickness
- sections and bars of all grades not exceeding 50 mm in thickness.

2.1.3 For thickness greater than the above, the requirements may be modified, as appropriate, in the individual cases.

2.1.4 (1/7/2015)

The requirements of this Section also apply to normal and higher strength Corrosion Resistant steels when such steel is used as the alternative means of corrosion protection for cargo oil tanks as specified in the performance standard MSC.289 (87) of Regulation 3-11, Part A-1, Chapter II-1 of the SOLAS Convention (Corrosion protection of cargo oil tanks of crude oil tankers). Corrosion Resistant steels, as defined within this Section, are steels whose corrosion resistance performance in the bottom or top of the internal cargo oil tank is tested and approved to satisfy the requirements in MSC.289 (87) in addition to other relevant requirements for hull structural steels, structural strength and construction. It is not intended that such steels be used for corrosion resistant applications in other areas of a vessel that are outside of those specified in the performance standard MSC.289 (87) of Regulation 3-11, Part A-1, Chapter II-1 of the SOLAS Convention. These requirements apply to plates, wide flats, sections and bars in all grades up to a maximum thickness of 50 mm.

2.2 Steel grades

2.2.1 The steels are classed, on the basis of a minimum yield strength level R_{eH} (N/mm²), into normal strength ($R_{eH} = 235$) and higher strength (32: $R_{eH} = 315 - 36$; $R_{eH} = 355 - 40$; $R_{eH} = 390$).

Normal strength steels are divided into four grades A, B, D and E. For normal strength steels, the letters A, B, D and E mean impact properties at +20, 0, -20 and -40°C, respectively.

Higher strength steels are divided into four grades identified by the letters AH, DH, EH and FH followed by a number related to the yield strength level. For higher strength steels, the letters AH, DH, EH and FH mean impact properties at 0, -20, -40 and -60°C, respectively.

2.2.2 Steels differing in chemical composition, deoxidation practice, conditions of supply and mechanical properties may be accepted, subject to the special approval of the Society. Such steels are to be given a special designation (see [1.9]).

2.3 Manufacture

2.3.1 Approval (1/7/2003)

The Manufacturers are to be approved by the Society and the relevant requirements of [1.2] apply.

It is the Manufacturer's responsibility to assure that effective process and production controls in operation are adhered to within the manufacturing specifications. Where control imperfection inducing possible inferior quality of product occurs, the manufacturer is to identify the cause and establish a countermeasure to prevent its recurrence. Also, the complete investigation report is to be submitted to the Surveyor.

For further use, each affected piece is to be tested to the Surveyor's satisfaction.

The frequency of testing for subsequent products offered may be increased at the discretion of the Society to gain confidence in the quality.

2.3.2 Deoxidation process

The method of deoxidation is specified in Tab 1 and Tab 2.

2.3.3 Dimensional tolerances (1/1/2023)

a) The tolerances on thickness of a given product are defined as:

- Minus tolerance is the lower limit of the acceptable range below the nominal thickness.
- Plus tolerance is the upper limit of the acceptable range above the nominal thickness.

For plates and wide flats, with widths of 600 mm or greater, with nominal thickness of 5 mm and over, the minus tolerance on nominal thickness is 0,3 mm irrespective of nominal thickness.

- b) The thickness tolerances for products below 5 mm are to be in accordance with a national or international standard, e.g. Class B of ISO 7452:2013. However, the minus tolerance shall not exceed 0,3 mm.
- c) The tolerances on nominal thickness are not applicable to areas repaired by grinding. For areas repaired by grinding the requirements in [2.3.6] are to be applied, unless stricter requirements as per a recognized standard are considered by the Society or purchaser.
- d) The plus tolerances on nominal thickness are to be in accordance with a recognized national or international standard unless required otherwise by the Society or purchaser.
- e) Tolerances for length, width, flatness and over thickness may be taken from national or international standards.
- f) Class C of ISO 7452:2013 or equivalent according to national or international standards may be applied in

lieu of the requirements in a) to d), in which case the requirements stated in g) and h) need not be applied.

Additionally, if Class C of ISO 7452:2013 is applied, it is required that the steel mill demonstrates to the satisfaction of the Society that the number of measurements and measurement distribution is appropriate to establish that the mother plates produced are at or above the specified nominal thickness.

- g) The average thickness of products is defined as the arithmetic mean of the measurements made in accordance with the requirements of h).

The average thickness of products is not to be less than the nominal thickness.

- h) The measurement locations apply to a product rolled directly from one slab or steel ingot even if the product is to be later cut by the manufacturer. Examples of the original measurements relative to later cut products are shown in Fig 8. It is to be noted that the examples shown are not representative of all possible cutting scenarios.

At least two lines among Line 1, Line 2 or Line 3 as shown in Fig 7 are to be selected for the thickness measurements and at least three points on each selected line as shown in Fig 7 are to be selected for thickness measurement. If more than three points are taken on each line, the number of points is to be equal on each line.

Automated method or manual method is applied to the thickness measurements.

- For automated methods, the measuring points at sides are to be located not less than 10 mm but not greater than 300 mm from the transverse or longitudinal edges of the product.
 - For manual methods, the measuring points at sides are to be located not less than 10 mm but not greater than 100 mm from the transverse or longitudinal edges of the product.
- i) The procedure and the records of measurements are to be made available to the Surveyor and copies provided on request.
- j) For sections and bars, the under thickness tolerance is to be in accordance with the requirements of a recognised international or national standard.
- k) The responsibility for verification and maintenance of the production within the required tolerances rests with the manufacturer. The Surveyor may require to witness some measurements.

2.3.4 Surface quality (1/7/2018)

The steel is to be free from surface defects prejudicial to the use of the material for the intended application.

The finished material is to have a surface quality in accordance with a recognized standard such as EN 10163 parts 1, 2 and 3, or an equivalent standard accepted by the Society, unless otherwise specified in this section.

The responsibility for meeting the surface finish requirements rests with the manufacturer of the material, who is to take the necessary manufacturing precautions and is to inspect the products prior to delivery. At that stage, however, rolling or heat treatment scale may conceal surface

discontinuities and defects. If, during the subsequent descaling or working operations, the material is found to be defective, the Society may require materials to be repaired or rejected.

The surface quality inspection method is to be in accordance with recognized national or international standards agreed between purchaser and manufacturer, accepted by the Society.

If agreed by the manufacturer and purchaser, steel may be ordered with improved surface finish over and above these requirements.

The surface quality and condition requirement herein are not applied to products in forms of bars and tubulars, which will be subject to manufacturers' conformance standards.

2.3.5 Acceptance Criteria (1/7/2018)

a) Imperfections:

Imperfections of a harmless nature, for example pitting, rolled-in scale, indentations, roll marks, scratches and grooves, regarded as being inherent of the manufacturing process, are permissible irrespective of their number, provided the maximum permissible limits of Class A of EN 10163-2 or limits specified in a recognized equivalent standard accepted by the Society, are not exceeded and the remaining plate or wide flat thickness remains within the average allowable minus thickness tolerance specified in [2.3.3].

Total affected area with imperfection not exceeding the specified limits are not to exceed 15% of the total surface in question.

b) Defects:

Affected areas with imperfections with a depth exceeding the limits of Class A of EN 10163-2 or the maximum

permissible limits specified in a recognized equivalent standard accepted by the Society, are to be repaired irrespective of their number.

Cracks, injurious surface flaws, shells (over lapping material with non-metallic inclusion), sand patches, laminations and sharp edged seams (elongated defects) visually evident on surface and/or edge of plate are considered defects, which would impair the end use of the product and which require rejection or repair, irrespective of their size and number.

2.3.6 Rectification of surface defects by grinding (1/7/2018)

Surface defects may be removed by grinding as indicated in [1.6.1] provided that:

- the nominal thickness will not be reduced by more than 7% or 3 mm, whichever is the lesser
- each single ground area does not exceed 0,25 m²
- the total area of local grinding does not exceed 2% of the total surface of the plate.

Adjacent repairs located at a distance less than their mean width are considered as forming a single ground area.

In the case of ground areas lying opposite each other on both surfaces of the plate, the resulting thickness is to satisfy in any place the values indicated in a).

Defects or unacceptable imperfections are to be completely removed by grinding and the remaining plate or wide flat thickness is to remain within the average allowable minus thickness tolerance specified in [2.3.3]. The ground areas are to be a smooth transition to the surrounding surface of the product. Complete elimination of the defect is to be verified by magnetic particle or by liquid penetrant testing.

Figure 7 : Locations of Thickness Measuring Points for the Original Steel Plates (1/1/2013)

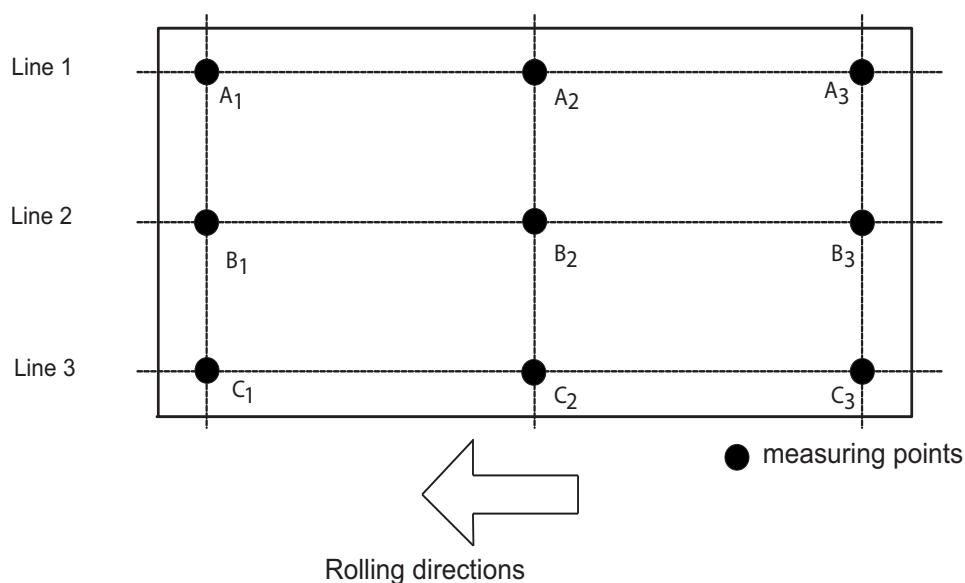
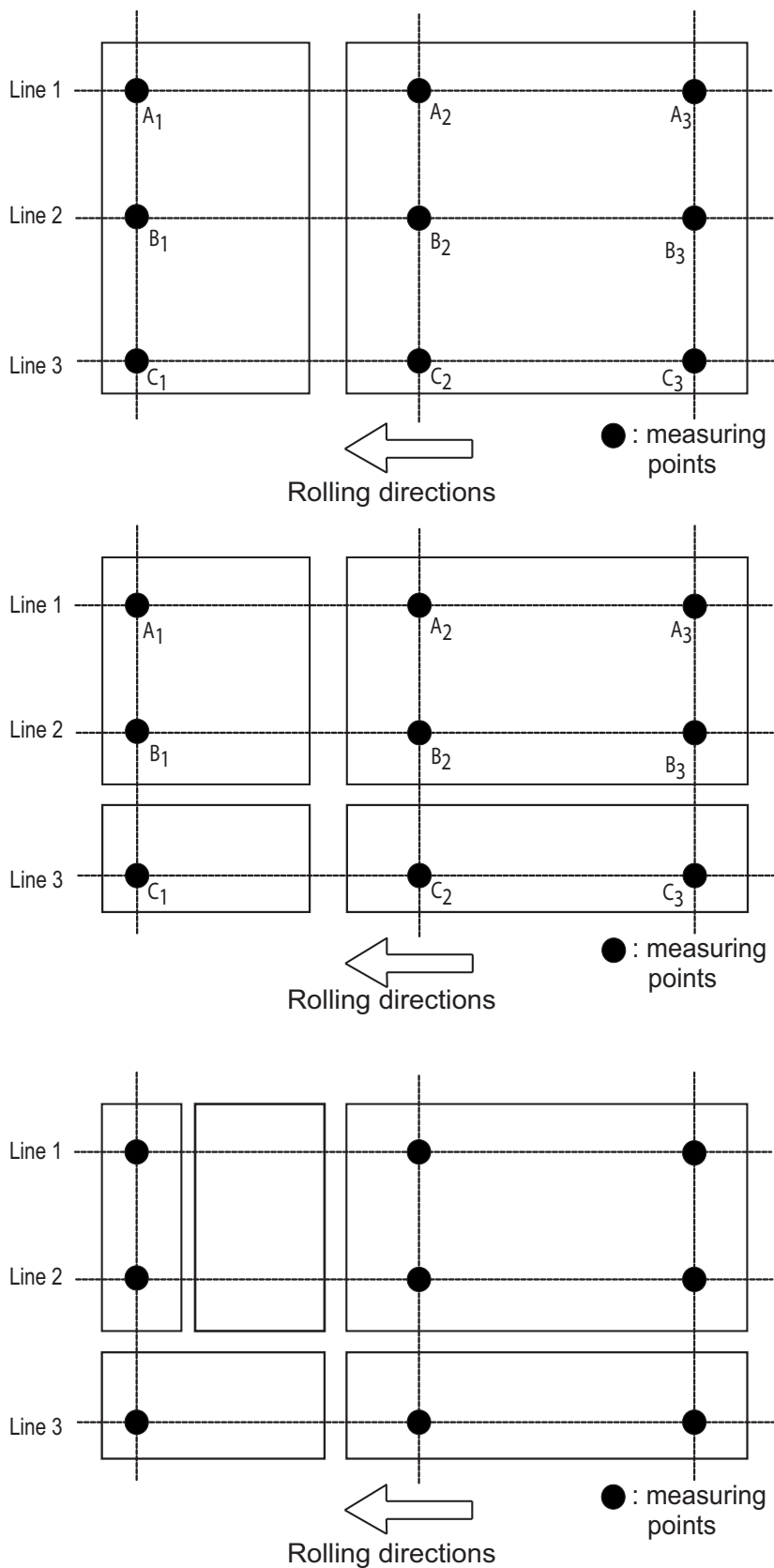

Figure 8 : Locations of Thickness Measuring Points for the Cut Steel Products (1/1/2013)



2.3.7 Rectification of surface defects by welding (1/7/2018)

Surface defects of products which cannot be removed as stated in [2.3.6] may be repaired by chipping or grinding followed by welding subject to the Surveyor's consent and under his supervision, provided that:

- a) after removal of defects and before welding, the thickness of the piece is in no place reduced by more than 20% with respect to the nominal thickness. For occasional defects with depths exceeding the 20% limit, special consideration at the Surveyor's discretion will be necessary.
- b) the repair is to be carried out by qualified welders using an approved procedure for the appropriate steel grade. The electrodes are to be of low hydrogen type and are to be dried in accordance with the manufacturer's requirements and protected against re-humidification before and during welding.
- c) no single welded area exceeds 0,125 m² and the sum of all welded areas does not exceed 2% of the total surface area of the plate
- d) the distance between two welded areas is not to be less than their average width.
- e) after the final grinding the piece is normalised or stress-relieved, where required by the Surveyor. For plates to be supplied in normalised condition, a new normalising heat treatment is required as a rule, except for repairs of negligible size, when the piece had already been normalised before repair. For products obtained by thermo-mechanical rolling processes, the conditions stated at the approval of the rolling process apply.
- f) repair of defects such as unacceptable imperfections, cracks, shells or seams are to be followed by magnetic particle or liquid penetrant testing.
- g) if weld repair depth exceeds 3 mm, UT may be requested by the Society. If required, UT is to be carried out in accordance with an approved procedure.

2.3.8 Internal soundness (1/7/2018)

If plates and wide flats are ordered with ultrasonic inspection, this is to be made in accordance with an accepted standard at the discretion of the Society.

Verification of internal soundness is the responsibility of the manufacturer. The acceptance of internal soundness by the

Society's surveyor does not absolve the manufacturer from this responsibility.

2.4 Condition of supply

2.4.1 The products are to be supplied in the condition indicated in Tab 5 and Tab 6 for normal strength steels and Tab 9 and Tab 10 for higher strength steels.

The definition of the supply conditions is given in [1.7.3].

2.5 Chemical composition

2.5.1 General

The chemical composition is determined by the Manufacturer on ladle samples (see Ch 1, Sec 1, [2.2.1]).

2.5.2 Normal strength steels

The chemical composition is to comply with the requirements specified in Tab 1.

2.5.3 Higher strength steels

The chemical composition is to comply with the requirements specified in Tab 2.

At the time of the approval of higher strength steels, an upper limit for carbon equivalent C_{EQ} on the ladle analysis may be specified.

Unless otherwise agreed, the value of C_{EQ} is calculated by the following formula:

$$C_{EQ} = C + \frac{Mn}{6} + \frac{Cr + Mo + V}{5} + \frac{Ni + Cu}{15} \quad \%$$

For steel produced by thermo-mechanical rolling, C_{EQ} is to comply with the requirements of Tab 3.

As an alternative to C_{EQ} , at the discretion of the Society, the cold cracking susceptibility P_{cm} may be used for evaluating the weldability.

P_{cm} is given by the following formula and an upper limit may be agreed at the time of the approval of the steel:

$$P_{cm} = C + \frac{Si}{30} + \frac{Mn}{20} + \frac{Cu}{20} + \frac{Ni}{60} + \frac{Cr}{20} + \frac{Mo}{15} + \frac{V}{10} + 5B \quad \%$$

When a limit of C_{EQ} and P_{cm} is required, the relevant values are to be stated by the Manufacturer and included in the testing documentation for each cast.

Table 1 : Normal strength steels - Chemical composition and deoxidation practice

Steel grade	A	B	D	E
Deoxidation practice for thickness t (mm)	t ≤ 50 mm: any method except rimmed (1) t > 50 mm: killed	t ≤ 50 mm: any method except rimmed t > 50 mm: killed	t ≤ 25 mm: killed t > 25 mm: killed and fine grain treated	killed and fine grain treated
Chemical composition (%) (2) (3) (4)				
C max (5)	0,21 (6)	0,21	0,21	0,18
Mn min (5)	2,5 x C	0,80 (7)	0,60	0,70
Si max	0,50	0,35	0,35	0,35
P max	0,035	0,035	0,035	0,035
S max	0,035	0,035	0,035	0,035
Al (acid soluble) min			0,015 (8) (9)	0,015 (9)
<p>(1) For sections up to a thickness of 12,5 mm, rimmed steel may be accepted subject to the special approval of the Society.</p> <p>(2) When any grade of steel is supplied in the thermo-mechanically rolled condition, variations in the specified chemical composition may be allowed or required by the Society and are to be stated at the approval.</p> <p>(3) The Society may limit the amount of residual elements which may have an adverse effect on the working and use of the steel, e.g. copper and tin.</p> <p>(4) Where additions of any other element have been made as part of the steelmaking practice, the content is to be indicated in the ladle analysis certificate.</p> <p>(5) C + 1/6 Mn is not to exceed 0,40%.</p> <p>(6) Max. 0,23% for sections.</p> <p>(7) When Grade B steel is impact tested, the minimum manganese content may be reduced to 0,60%.</p> <p>(8) Al is required for thickness greater than 25 mm.</p> <p>(9) The total aluminum content may be determined instead of acid soluble content. In such cases the total aluminum content is to be not less than 0,020%. Other suitable grain refining elements may be used subject to the special approval of the Society.</p>				

Table 2 : Higher strength steels - Chemical composition and deoxidation practice

Steel grade	AH32, DH32, EH32 AH36, DH36, EH36 AH40, DH40, EH40	FH32, FH36, FH40
Deoxidation practice	killed and fine grain treated	killed and fine grain treated
Chemical composition (%) (1) (5)		
C max.	0,18	0,16
Mn	0,90 - 1,60 (2)	0,90 - 1,60
Si max.	0,50	0,50
P max.	0,035	0,025
S max.	0,035	0,025
Al (acid soluble) min (3) (4)	0,015	0,015
Nb (4)	0,02 - 0,05	0,02 - 0,05
V (4)	0,05 - 0,10	0,05 - 0,10
Ti max. (4)	0,02	0,02
Cu max.	0,35	0,35
Cr max.	0,20	0,20
Ni max.	0,40	0,80
Mo max.	0,08	0,08
N max.		0,009 (0,012 if Al is present)
<p>(1) Alloying elements other than those listed above or exceeding the specified limits may be accepted by the Society when proposed by the steelmaker at the time of approval and their content is to be indicated in the ladle analysis.</p> <p>(2) Up to a thickness of 12,5 mm, the minimum manganese content may be reduced to 0,70%.</p> <p>(3) The total aluminium content may be determined instead of the acid soluble content. In such cases the total aluminium content is to be not less than 0,020 %.</p> <p>(4) The steel is to contain aluminium, niobium, vanadium or other suitable grain refining elements, either singly or in any combination. When used singly, the steel is to contain the specified minimum content of the grain refining element. When used in combination, the specified minimum content of at least one grain refining element is applicable; the sum of Nb+V+Ti is not to exceed 0,12%.</p> <p>(5) When any grade of higher strength steel is supplied in the thermo-mechanically rolled condition, variations in the specified chemical composition may be allowed or required by the Society and are to be stated at the approval.</p>		

Table 3 : Carbon equivalent for higher strength steels up to 100 mm in thickness produced by TM process (1/7/2005)

Steel grade	Carbon equivalent C _{EO} max. (%) (1)	
	t ≤ 50	50 < t ≤ 100
AH32, DH32, EH32, FH32	0,36	0,38
AH36, DH36, EH36, FH36	0,38	0,40
AH40, DH40, EH40, FH40	0,40	0,42
t = thickness (mm)		
(1) More stringent carbon equivalent limits may be agreed between the Manufacturer and the shipbuilder in individual cases.		

2.6 Mechanical Properties

2.6.1 Normal strength steels

The mechanical properties are indicated in Tab 4.

The number of impact tests to be performed is indicated in Tab 5 for plates and wide flats and Tab 6 for sections and bars.

2.6.2 Higher strength steels

The mechanical properties are indicated in Tab 7.

The condition of supply and the number of impact tests to be performed are indicated in Tab 9 for plates and wide flats and Tab 10 for sections and bars.

2.7 Mechanical Tests

2.7.1 General

Samples for mechanical tests are to be cut from the products in the final supply condition. The tests are to be carried out on pieces selected from batches or on individual pieces as required in [2.7.5] and [2.7.6].

2.7.2 Batch testing

All materials in the batch are to be from the same heat, of the same product type, in the same condition of supply and within the following ranges of thickness and mass:

- difference between minimum and maximum thickness not exceeding 10 mm
- mass not exceeding 50 t.

For products of steel type A intended for secondary applications, the batch composition may not be required to be restricted to material from the same heat, but in such case the mass of the batch is not to exceed 25 t.

2.7.3 Individual testing

For tests on individual pieces the term piece means rolled unit as defined in Ch 1, Sec 1, [3.3.3].

2.7.4 Sampling

For plates and flats having width ≥ 600 mm, the specimens for tensile test are to be taken in the transverse direction and the specimens for the Charpy V impact test in the longitudinal direction (KVL).

In other cases the specimens are to be taken in the longitudinal direction, unless otherwise required by or agreed with the Society.

The impact test requirements specified on transverse specimens (KVT) are to be fulfilled by the Manufacturer and random checks may be required by the Society.

Generally, impact tests are not required when the nominal product thickness is less than 6 mm.

For plates fabricated in coils, the tensile and impact tests required are to be duplicated on specimens taken from samples cut at both ends of the coil.

Sampling positions are indicated in [1.8.2].

Additional through thickness tests may be required for special applications and are to be carried out according to the requirements of Article [9].

Table 4 : Normal strength steels - Mechanical properties

Steel grade	Yield stress R _{eH} (N/mm ²) min.	Tensile strength R _m (N/mm ²)	El. A ₅ (%) min (1)	Average impact energy (J) min KVL longitudinal - KVT transverse - t = thickness (mm)						
				Test temp (°C)	t ≤ 50		50 < t ≤ 70		70 < t ≤ 100	
					KVL	KVT	KVL	KVT	KVL	KVT
A	235	400/520 (2)	22	+20			34	24	41	27
B	235	400/520	22	0	27	20	34	24	41	27
D	235	400/520	22	-20	27	20	34	24	41	27
E	235	400/520	22	-40	27	20	34	24	41	27

(1) El. : elongation. For full thickness flat tensile test specimens with a width of 25 mm and a gauge length of 200mm, the elongation is to comply with the minimum values given for strength level 32 in Tab 8.

(2) For sections in grade A of all thicknesses, the upper limit for the specified tensile stress range may be exceeded up to a maximum of 540 N/mm².

Table 5 : Normal strength plates and wide flats - Condition of supply and number of impact tests

Steel grade	Condition of supply (1) Batch for impact tests in t () for thickness t (mm) (2)			
	t ≤ 25	25 < t < 35	35 ≤ t ≤ 50	50 < t ≤ 100
A	A(-)			(3) (N, TM)(-) NR(50) AR*(50)
B	(4) A (-)	A(50)		(N, TM)(50) NR(25) AR*(25)
D	A(50)		(N, NR, TM)(50)	(N, TM)(50) NR(25)
E	N or TM (each piece)			
<p>(1) Abbreviations: A : Any N : Normalised Condition (heat treatment) NR : Normalising Rolled Condition as an alternative to Normalising TM : Thermo-Mechanical Rolling AR* : As Rolled Condition subject to the special approval of the Society.</p> <p>(2) One set of impact tests is to be taken from each batch of the weight in t specified in brackets (), from each fraction thereof or from each piece as indicated. When impact tests are not required the indication is (-).</p> <p>(3) Charpy V-notch tests are generally not required for fine grained grade A products over 50 mm thick N or TM; when required, the rate is at the Society's discretion.</p> <p>(4) Charpy V-notch tests are generally not required for Grade B steel with thickness of 25 mm or less; when required, the rate is at the Society's discretion.</p>				

**Table 6 : Normal strength sections and bars
Condition of supply and number of impact tests**

Steel grade	Condition of supply (1) Batch for impact tests in t () for thickness t (mm) (2)		
	t ≤ 25	25 < t ≤ 35	35 < t ≤ 50
A	A (-)		
B	(3) A (-)	A (50)	
D	A (50)		N(50) NR(50) TM(50) AR*(25)
E	N(25) TM(25) AR*(15) NR*(15)		
<p>(1) Abbreviations: A : Any N : Normalised Condition (heat treatment) NR : Normalising Rolled Condition as an alternative to Normalising TM : Thermo-Mechanical Rolling AR* : As Rolled Condition subject to the special approval of the Society NR* : Normalising Rolled Condition subject to the special approval of the Society.</p> <p>(2) One set of impact tests is to be taken from each batch of the weight in t specified in brackets () or fraction thereof. When impact tests are not required, the indication is (-).</p> <p>(3) Charpy V-notch impact tests are generally not required for Grade B steel with thickness of 25 mm or less.</p>			

Table 7 : Higher strength steels - Mechanical properties (1/7/2003)

Steel grade	Yield stress R_{eH} (N/mm ²) min.	Tensile strength R_m (N/mm ²)	Elong. A_5 (%) min. (1)	Average impact energy (J) min. for thickness t (mm)						
				Test temp. (°C)	t ≤ 50		50 < t ≤ 70		70 < t ≤ 100	
					KVL	KVT	KVL	KVT	KVL	KVT
AH32 DH32 EH32 FH32	315	440/570	22	0	31	22	38	26	46	31
- 20				31	22	38	26	46	31	
- 40				31	22	38	26	46	31	
- 60				31	22	38	26	46	31	
AH36 DH36 EH36 FH36	355	490/630	21	0	34	24	41	27	50	34
- 20				34	24	41	27	50	34	
- 40				34	24	41	27	50	34	
- 60				34	24	41	27	50	34	
AH40 DH40 EH40 FH40	390	510/660	20	0	39	26	46	31	55	37
-20				39	26	46	31	55	37	
- 40				39	26	46	31	55	37	
- 60				39	26	46	31	55	37	

(1) For full thickness flat tensile test specimens with a width of 25 mm and a gauge length of 200 mm, the elongation is to comply with the minimum values given in Tab 8.

Table 8 : Elongation (%) on a gauge length of 200 mm for thickness t (mm)

Strength grade	t ≤ 5	5 < t ≤ 10	10 < t ≤ 15	15 < t ≤ 20	20 < t ≤ 25	25 < t ≤ 30	30 < t ≤ 40	40 < t ≤ 50
32	14	16	17	18	19	20	21	22
36	13	15	16	17	18	19	20	21
40	12	14	15	16	17	18	19	20

Table 9 : Higher strength plates and wide flats - Condition of supply and number of impact tests (1/7/2003)

Steel grade	Grain refining elements	Condition of supply (1)					
		Batch for impact tests in t () for thickness t (mm) up to: (2)					
		12,5	20	25	35	50	100
AH32 (3)	Nb and/or V	A(50)	N(50), NR(50), TM(50)			N(50), NR(25), TM(25)	
AH36 (3)	Al only or with Ti	A(50)	AR*(25)		Not applicable		
			N(50), NR(50), TM(50)			N(50), NR(25), TM(50)	
AH40	Any	A(50)	N(50), NR(50), TM(50)			N(50), TM(50), QT (each length as heat treated)	
DH32	Nb and/or V	A(50)	N(50), NR(50), TM(50)			N(50), NR(25), TM(50)	
DH36	Al only or with Ti	A(50)	AR*(25)		Not applicable		
			N(50), NR(50), TM(50)			N(50), NR(25), TM(50)	
DH40	Any	N(50), NR(50), TM(50)				N(50), TM(50), QT (each length as heat treated)	
EH32 EH36	Any	N (each piece) TM (each piece)					
EH40	Any	N (each piece), TM (each piece) QT (each length as heat treated)				N (each piece), TM (each piece), QT (each length as heat treated)	
FH32 FH36	Any	N (each piece), TM (each piece) QT (each length as heat treated)				N (each piece), TM (each piece), QT (each length as heat treated)	
FH40	Any	N (each piece), TM (each piece) QT (each length as heat treated)				N (each piece), TM (each piece), QT (each length as heat treated)	
<p>(1) Abbreviations:</p> <p>A : Any</p> <p>N : Normalised Condition (heat treatment)</p> <p>NR : Normalising Rolled Condition as an alternative to Normalising</p> <p>TM : Thermo-Mechanical Rolling</p> <p>QT : Quenched and Tempered Condition</p> <p>AR* : As Rolled Condition subject to the special approval of the Society.</p> <p>(2) One set of impact tests is to be taken from each batch of the weight in t specified in brackets (), from each fraction thereof or from each piece as indicated. When impact tests are not required the indication is (-).</p> <p>(3) For Grades AH32 and AH36 steels, a relaxation in the number of impact tests may be permitted by special agreement with the Society, provided that satisfactory results are obtained from occasional checks.</p>							

2.7.5 Number of tensile tests

One tensile test is to be carried out from one piece for each batch presented or fraction thereof.

In general the specimen is to be taken from a piece selected in the batch among those with the highest thickness.

2.7.6 Number of impact tests (1/7/2003)

The number of sets of impact tests required is indicated in Tab 5 and Tab 6 for normal strength products and Tab 9 and Tab 10 for higher strength products.

When testing is by batches, the specimens are to be taken from a piece selected among those of the batch having the highest thickness.

The number of sets of specimens for the impact test, each of three specimens, summarised in the above-mentioned Tables, is to be in accordance with the following requirements:

- one set is required for each batch of 50, or fraction thereof for the following grades of steel, unless otherwise specified in b):
 - A, for products having thickness ≥ 50 mm
 - B, for products having thickness ≥ 25 mm
 - D, AH32, DH32, AH36, DH36, AH40, DH40
- For steel plates of Grades AH40 and DH40 with thickness over 50mm in normalised or TM condition, one set of impact test specimens is to be taken from each batch of 50 t or fraction thereof. For those in QT condition, one set of impact test specimens is to be taken from each length as heat treated.
- except for grade A, for products supplied subject to special approval in the as rolled condition (AR*), and for products with thickness higher than 50 mm supplied in the controlled rolled condition (NR), the mass of the batches for the purpose of impact tests is to be 25 t, or a fraction thereof
- one set of three impact test specimens is required for:
 - each piece for grades E and F in all strengths

- each batch of 25 t or fraction thereof of sections of grades E and F in all strengths
- e) when, subject to special approval, sections of steel grades E and F in all strengths other than 40 are supplied in the as rolled (AR*) or controlled rolled (NR*) condi-

tion, the mass of the batches for the purpose of impact tests is to be 15 t, or a fraction thereof.

Random checks of the impact values may be required at the discretion of the Surveyor.

Table 10 : Higher strength sections and bars - Condition of supply and number of impact tests

Steel grade	Grain refining elements	Condition of supply (1)		
		Batch for impact test in t () for thickness t (mm) up to : (2)		
		12,5	20	50
AH32 (3)	Nb and/or V	A(50)	N(50), NR(50), TM(50), AR*(25)	
AH36 (3)	Al only or with Ti	A(50)		N(50), NR(50), TM(50), AR*(25)
AH40	Any	A(50)	N(50), NR(50), TM(50)	
DH32	Nb and/or V	A (50)	N(50), NR(50), TM(50), AR*(25)	
DH36	Al only or with Ti	A(50)		N(50), NR(50), TM(50), AR*(25)
DH40	Any	N(50), NR(50), TM(50)		
EH32	Any	N(25), TM(25), AR*(15), NR*(15)		
EH36				
EH40	Any	N(25), TM(25), QT(25)		
FH32	Any	N(25), TM(25), QT(25), NR*(15)		
FH36				
FH40	Any	N(25), TM(25), QT(25)		
<p>(1) Abbreviations :</p> <p>A : Any</p> <p>N : Normalised Condition (heat treatment)</p> <p>NR : Normalising Rolled Condition as an alternative to Normalising</p> <p>TM : Thermo-Mechanical Rolling</p> <p>QT : Quenched and Tempered Condition</p> <p>AR* : As Rolled Condition subject to the special approval of the Society</p> <p>NR* : Normalising Rolled Condition subject to the special approval of the Society.</p> <p>(2) One set of impact tests is to be taken from each batch of the weight in t specified in brackets () or fraction thereof.</p> <p>(3) For Grades AH32 and AH36 steels, a relaxation in the number of impact tests for acceptance purposes may be permitted by special agreement with the Society provided that satisfactory results are obtained from occasional checks.</p>				

3 High Strength Steels for Welded Structures

3.1 Application

3.1.1 (1/7/2017)

These requirements apply to hot-rolled, fine-grain, weldable high strength structural steels, intended for use in marine structural applications. These requirements do not apply to steels intended for hull structure of ships whose requirements are specified in [2].

3.2 Steel grades

3.2.1 (1/7/2017)

Steels covered by the scope of these requirements are specified in yield strength levels ReH (N/mm²) of 420, 460, 500, 550, 620, 690, 890 and 960 N/mm². For each yield strength level grades AH, DH, EH and FH are specified, based on

the impact test temperature, except for yield strength level of 890 and 960 N/mm² for which grade FH is not applicable.

The letters AH, DH, EH and FH mean impact test properties at 0, -20, -40 and -60 °C, respectively.

3.3 Condition of supply

3.3.1 (1/7/2017)

Steels covered by the scope of this Article may be delivered in Normalized (N)/Normalised rolled (NR); Thermo-mechanical controlled rolled (TM) or Quenched and Tempered (QT) condition.

Note 1: TM is a generic delivery condition that may or may not include accelerated cooling, and may or may not include direct quenching followed by tempering after TM-rolling.

Product forms include plates, wide flats, sections, bars and seamless tubulars.

3.4 Approval

3.4.1 (1/7/2017)

For applications subjected to Classification, all steels are to be manufactured at steel works which have been approved by the Society for the type and grade of steel which is being supplied.

3.4.2 (1/7/2017)

It is the steelmaker's responsibility to assure that effective quality, process and production controls during manufacturing are adhered to within the manufacturing specification. The manufacturing specification is to be submitted to the Society at the time of initial approval.

3.4.3 (1/7/2017)

Where non-conformities arise, the manufacturer is to identify the root cause and establish countermeasures to prevent its recurrence. The non-conformities and the countermeasures are to be documented and reported to the Society.

3.4.4 (1/7/2017)

When the semi-finished products were not manufactured by the approved manufacturer of the finish rolled and heat treated products, the manufacturer of the semi-finished product is also to be subject to approval by the Society.

3.4.5 (1/7/2017)

Steels with a thickness beyond the maximum thicknesses as given in Tab 13 may be approved at the discretion of the Society.

3.4.6 (1/7/2017)

Steels differing in chemical composition, deoxidation practice, delivery condition and mechanical properties may be accepted, subject to the special approval of the Society. Such steels are to be given a special designation (ref. to [3.18]).

Note 1: The attention of the users is to be drawn to the fact that when fatigue loading is present, the effective fatigue strength of a welded joint of high strength steel may not be greater than that of a welded joint in normal strength steels.

Note 2: Before subjecting steels produced by both thermo-mechanical rolling or quenched and tempered after rolling to further heating for forming or stress relieving, or using high heat-input welding, special consideration is to be given to the possibility of a consequent reduction in mechanical properties.

3.5 Method of Manufacture

3.5.1 Steel making process (1/7/2017)

The steel is to be manufactured, by the basic oxygen, basic electric arc furnace or by processes specially approved by the Society.

Vacuum degassing is to be used for any of the following:

- All steels with enhanced through-thickness properties, and
- All steels of grade H690, H890 and H960.

3.5.2 Deoxidation (1/7/2017)

The steel is to be fully killed.

3.5.3 Grain size (1/7/2017)

The steel is to be fine grain treated, and is to have a fine grain structure. The fine grain practice is to be as detailed in the manufacturing specification.

Note 1: A fine grain structure has an equivalent index ≥ 6 determined by micrographic examination in accordance with ISO 643 or alternative test method.

3.5.4 Nitrogen control (1/7/2017)

The steels shall contain nitrogen binding elements as detailed in the manufacturing specification. Also see note 4 in Tab 11.

3.6 Chemical composition

3.6.1 (1/7/2017)

The chemical composition is to be determined by the steelmaker in an adequately equipped and competently staffed laboratory. The method of sampling is to follow that carried out for the initial approval tests, either from the ladle, the tundish or the mould in the case of continuous casting. The aim analysis is to be in accordance with the manufacturing specification. All the elements listed in Tab 11 are to be reported.

3.6.2 (1/7/2017)

Elements used for alloying, nitrogen binding, and fine grain treatment, and as well as the residual elements are to be as detailed in the manufacturing specification, e.g. when boron is deliberately added for enhancement of hardenability of the steels, the maximum content of the boron content shall not be higher than 0.005%; and the analysis result shall be reported.

3.6.3 (1/7/2017)

The carbon equivalent value is to be calculated from the ladle analysis. Maximum values are specified in Tab 12.

- a) For all steel grades the following formula may be used:

$$C_{eq} = C + \frac{Mn}{6} + \frac{Cr + Mo + V}{5} + \frac{Ni + Cu}{15} \quad \%$$

- b) For steel grades H460 and higher, CET may be used instead of C_{eq} at the discretion of the manufacturer, and is to be calculated according to the following formula:

$$CET = C + \frac{(Mn + Mo)}{10} + \frac{(Cr + Cu)}{20} + \frac{Ni}{40} \quad \%$$

Note 1: The CET is included in the standard EN 1011-2:2001 used as one of the parameters for pre-heating temperature determination which is necessary for avoiding cold cracking.

- c) For TM and QT steels with carbon content not more than 0.12%, the cold cracking susceptibility P_{cm} for evaluating weldability may be used instead of carbon equivalent of C_{eq} or CET at manufacturer's discretion and is to be calculated using the following formula:

$$P_{cm} = C + \frac{Si}{30} + \frac{Mn}{20} + \frac{Cu}{20} + \frac{Ni}{60} + \frac{Cr}{20} + \frac{Mo}{15} + \frac{V}{10} + 5B \quad \%$$

Table 11 : Chemical composition (1/7/2017)

Delivery condition (1)	N/NR		TM		QT	
Steel grade				EH420 FH420	AH420 DH420	EH420 FH420
	AH420 DH420 AH460 DH460	EH420 EH460	AH420 DH420 AH460 DH460 AH500 DH500 AH550 DH550 AH620 DH620 AH690 DH690	EH460 FH460 EH500 FH500 EH550 FH550 EH620 FH620 EH690 FH690 DH890 EH890	AH460 DH460 AH500 DH500 AH550 DH550 AH620 DH620 AH690 DH690 AH890 AH960	EH460 FH460 EH500 FH500 EH550 FH550 EH620 FH620 EH690 FH690 DH890 EH890 DH960 EH960
Chemical composition (2)						
C max	0,20	0,18	0,16	0,14	0,18	
Mn max	1,0 - 1,70		1,0 - 1,70		1,70	
Si max	0,60		0,60		0,80	
P max (3)	0,030	0,025	0,025	0,020	0,025	0,020
S max (3)	0,025	0,020	0,015	0,010	0,015	0,010
Al total min (4)	0,02		0,02		0,018	
Nb max (5)	0,05		0,05		0,06	
V max (5)	0,02		0,02		0,018	
Ti max (5)	0,05		0,05		0,06	
Ni max (6)	0,80		2,00 (6)		2,00 (6)	
Cu max	0,55		0,55		0,50	
Cr max (5)	0,30		0,50		1,50	
Mo max (5)	0,10		0,50		0,70	
N max	0,025		0,025		0,015	
O max ppm (7)	Not applicable		Not applicable	50	Not applicable	30
<p>(1) See [3.7.1] for definition of delivery conditions.</p> <p>(2) The chemical composition is to be determined by ladle analysis and is to meet the approved manufacturing specification at the time of approval.</p> <p>(3) For sections the P and S content can be 0.005% higher than the value specified in the table.</p> <p>(4) The total aluminium to nitrogen ratio is to be a minimum of 2:1. When other nitrogen binding elements are used, the minimum Al value and Al/N ratio do not apply.</p> <p>(5) Total Nb+V+Ti ≤ 0.26% and Mo+Cr ≤ 0.65%, not applicable for QT steels.</p> <p>(6) Higher Ni content may be approved at the discretion of the Society.</p> <p>(7) The requirement on maximum Oxygen content is only applicable to DH890; EH890; DH960 and EH960.</p>						

Table 12 : Maximum Ceq, CET and Pcm values (1/7/2017)

Strength level	Delivery condition	Carbon Equivalent (%)							
		Ceq						CET	Pcm
		Plates			Sections	Bars	Tubulars	all	all
		t ≤ 50 (mm)	50 < t ≤ 100 (mm)	100 < t ≤ 250 (mm)	t ≤ 50 (mm)	t ≤ 250 or d ≤ 250 (mm)	t ≤ 65 (mm)	all	all
420	N/NR	0,46	0,48	0,52	0,47	0,53	0,47	N.A.	N.A.
	TM	0,43	0,45	0,47	0,44	N.A.	N.A.	N.A.	N.A.
	QT	0,45	0,47	0,49	N.A.	N.A.	0,46	N.A.	N.A.
460	N/NR	0,50	0,52	0,54	0,51	0,55	0,51	0,25	N.A.
	TM	0,45	0,47	0,48	0,46	N.A.	N.A.	0,30	0,23
	QT	0,47	0,48	0,50	N.A.	N.A.	0,48	0,32	0,24
500	TM	0,46	0,48	0,50	N.A.	N.A.	N.A.	0,32	0,24
	QT	0,48	0,50	0,54	N.A.	N.A.	0,50	0,34	0,25
550	TM	0,48	0,50	0,54	N.A.	N.A.	N.A.	0,34	0,25
	QT	0,56	0,60	0,64	N.A.	N.A.	0,56	0,36	0,28
620	TM	0,50	0,52	N.A.	N.A.	N.A.	N.A.	0,34	0,26
	QT	0,56	0,60	0,64	N.A.	N.A.	0,58	0,38	0,30
690	TM	0,56	N.A.	N.A.	N.A.	N.A.	N.A.	0,36	0,30
	QT	0,64	0,66	0,70	N.A.	N.A.	0,68	0,40	0,33
890	TM	0,60	N.A.	N.A.	N.A.	N.A.	N.A.	0,38	0,28
	QT	0,68	0,75	N.A.	N.A.	N.A.	N.A.	0,40	N.A.
960	QT	0,75	N.A.	N.A.	N.A.	N.A.	N.A.	0,40	N.A.

Note 1: N.A = Not applicable

3.7 Delivery Condition - Rolling Process and Heat Treatment

3.7.1 (1/7/2017)

Steel is to be delivered in accordance with the processes approved by the Society. These processes include:

- Normalized (N)/Normalized rolled (NR)
- Thermo-mechanical controlled rolled (TM)/with Accelerated cooling (TM+AcC)/with direct quenching followed by tempering (TM+DQ), or
- Quenched and Tempered condition (QT)

The definition of these delivery conditions are defined in [1.7].

Note 1: Direct quenching after hot-rolling followed by tempering is considered equivalent to conventional quenching and tempering.

3.7.2 Rolling reduction ratio (1/7/2017)

The rolling reduction ratio of slab, billet, bloom or ingot should not be less than 3:1 unless agreed at the time of approval.

3.7.3 Thickness limits for approval (1/7/2017)

The maximum thickness of slab, billet or bloom from the continuous casting process shall be at the manufacturer's discretion.

Maximum thickness of plates, sections, bars and tubulars over which a specific delivery condition is applicable are shown in Tab 13.

Table 13 : Maximum thickness limits (1/7/2017)

Delivery condition	Maximum thickness (mm)			
	Plates	Sections	Bars	Tubulars
N	250 (2)	50	250	65
NR	150	(1)		
TM	150	50	Not applicable	Not applicable
QT	150	50	Not applicable	50

(1) The maximum thickness limits of sections, bars and tubulars produced by NR process route are less than those manufactured by N route, and are to be at the discretion of Society.

(2) Approval for N steels with thickness larger than 250 mm and QT steels with thickness larger than 150 mm is subject to the special consideration of the Society.

3.8 Mechanical properties

3.8.1 (1/7/2017)

Test specimens and test procedures for mechanical properties are to be in accordance with Ch 1, Sec 2 and [1.8].

3.8.2 Tensile test (1/7/2017)

Test specimens are to be cut with their longitudinal axes transverse to the final direction of rolling, except in the case of sections, bars, tubulars and rolled flats with a finished width of 600 mm or less, where the tensile specimens may be taken in the longitudinal direction.

Tensile test sample is to be randomly selected from each batch, that is to be less than or equal to 25 tonnes, and to be from the same cast, in the same delivery condition and of the same thickness.

Full thickness flat tensile specimens are to be prepared. The specimens are to be prepared in such a manner as to maintain the rolling scale at least at one side. When the capacity of the test machine is exceeded by the use of a full thickness specimen, sub-sized flat tensile specimens representing either the full thickness or half of the product thickness retaining one rolled surface are to be used. Alternatively, machined round test specimens may be used. The specimens are to be located at a position lying at a distance of $t/4$ from the surface and additionally at $t/2$ for thickness above 100 mm or as near as possible to these positions.

The results of the tests are to comply with the appropriate requirements of Tab 14. In the case of product forms other than plates and wide flats where longitudinal tests are agreed, the elongation values are to be 2 percentage units above those transverse requirements as listed in Tab 14.

3.8.3 Impact test (1/7/2017)

The Charpy V-notch impact test specimens for plates and wide flats over 600 mm in width are to be taken with their axes transverse to the final rolling direction and the results are to comply with the appropriate requirements for transverse direction of Tab 14. For other product forms, the impact tests are to be in the longitudinal direction, the results of the tests are to comply with the appropriate requirements for longitudinal direction of Tab 14.

Sub-surface test specimens will be taken in such a way that one side is not further away than 2 mm from a rolled surface, however, for material with a thickness in excess of 50 mm, impact tests shall be taken at the quarter thickness ($t/4$) location and mid-thickness ($t/2$).

Impact test for a nominal thickness less than 6 mm are normally not required.

Impact test frequency:

- For steels plates in N/NR or TM condition test sample is to be taken from each piece.
- For steels in QT condition test sample is to be taken from each individually heat treated part thereof.
- For sections, bars and tubulars, test sample is to be taken from each batch of 25 tonnes or fraction thereof.

Note 1: If the mass of the finished material is greater than 25 tonnes, one set of tests from each 25 tonnes and/or fraction thereof is required. (e.g.: a batch of 60 tonnes would require 3 plates to be tested).

Note 2: For continuous heat treated product special consideration may be given to the number and location of test specimens required by the manufacturer to be agreed by the Society.

Table 14 : Tensile properties at ambient temperature for all steel grades (1/7/2017)

Steel grade	Minimum yield strength R_{eH} (1) (N/mm ²)			Ultimate tensile strength R_m (N/mm ²)		Minimum percentage elongation after fracture (%) (2)		Charpy V-notch impact test		
	Nominal thickness (mm) (4)			Nominal thickness (mm) (4)		$L_0 = 5,65\sqrt{S_0}$		Test temp (°C)	Minimum (J)	
	≥ 3 ≤ 50	> 50 ≤ 100	> 100 ≤ 250	≥ 3 ≤ 100	> 100 ≤ 250	T	L (3)		T	L
AH420 DH420 EH420 FH420	420	390	365	520-680	470-650	19	21	0 -20 -40 -60	28	42
AH460 DH460 EH460 FH460	460	430	390	540-720	500-710	17	19	0 -20 -40 -60	31	44
AH500 DH500 EH500 FH500	500	480	440	590-770	540-720	17	19	0 -20 -40 -60	33	50
AH550 DH550 EH550 FH550	550	530	490	640-820	590-770	16	18	0 -20 -40 -60	37	55
AH620 DH620 EH620 FH620	620	580	560	700-890	650-830	15	17	0 -20 -40 -60	41	62
AH690 DH690 EH690 FH690	690	650	630	770-940	710-900	14	16	0 -20 -40 -60	46	69
AH890 DH890 EH890	890	830	N.A.	940-1100	N.A.	11	13	0 -20 -40	46	69
AH960 DH960 EH960	960	N.A.	N.A.	980-1150	N.A.	10	12	0 -20 -40	46	69

(1) For tensile test either the upper yield stress (R_{eH}) or where R_{eH} cannot be determined, the 0.2 percent proof stress ($R_p0.2$) is to be determined and the material is considered to comply with the requirement if either value meets or exceeds the specified minimum value of yield strength.

(2) For full thickness flat test specimens with a width of 25 mm and a gauge length of 200 mm the elongation is to comply with the minimum values shown in Tab 15.

(3) In the case that the tensile specimen is parallel to the final rolling direction, the test result is to comply with the requirement of elongation for longitudinal (L) direction.

(4) For plates and sections for applications, such as racks in offshore platforms etc, where the design requires that tensile properties are maintained through the thickness, a decrease in the minimum specified tensile properties is not permitted with an increase in the thickness.

Table 15 : Minimum elongation values for flat specimens 25 mm width and 200 mm gauge length (1) (1/7/2017)

Strength level	Thickness t (mm)						
	t ≤ 10	10 < t ≤ 15	15 < t ≤ 20	20 < t ≤ 25	25 < t ≤ 40	40 < t ≤ 50	50 < t ≤ 70
420	11	13	14	15	16	17	18
460	11	12	13	14	15	16	17
500	10	11	12	13	14	15	16
550	10	11	12	13	14	15	16
620	9	11	12	12	13	14	15
690	9 (2)	10 (2)	11 (2)	11	12	13	14

(1) The tabulated elongation minimum values are the requirements for testing specimen in transverse direction. 890 and 960 specimens and specimens which are not included in this table shall be proportional specimens with a gauge length of:

$$L_0 = 5,65\sqrt{S_0}$$

(2) For 690 plates with thickness ≤ 20 mm, round specimen in accordance with Ch 1, Sec 2, [2] may be used instead of the flat tensile specimen. The minimum elongation for testing specimen in transverse direction is 14%.

3.9 Traceability

3.9.1 (1/7/2017)

Traceability of test material, specimen sampling and test procedures including test equipment with respect to mechanical properties testing, is to be in accordance with [1.9].

3.10 Re-test procedures

3.10.1 (1/7/2017)

Re-test procedures for tensile tests and Charpy impact tests are to be in accordance with Ch 1, Sec 2.

3.11 Through thickness tensile test

3.11.1 (1/7/2017)

For steels designated with improved through thickness properties, through thickness tensile tests are to be performed in accordance with [9].

3.11.2 (1/7/2017)

Subject to the discretion of the Society, through thickness tensile strength may be required to be not less than 80% of the specified minimum tensile strength.

3.12 Tolerances

3.12.1 (1/7/2017)

Unless otherwise agreed or specially required, the thickness tolerances in [2.3.3] are applicable.

3.13 Surface Quality

3.13.1 (1/7/2017)

All materials are to be free from cracks, injurious surface flaws, injurious laminations and similar defects.

3.13.2 (1/7/2017)

The surface quality inspection method is to be in accordance with recognised national or international standards agreed between purchaser and manufacturer.

- Welding repair procedures and the method for reporting repairs are to be approved by the Society.
- Where repair by grinding is carried out then the remaining plate thickness below the ground area must be within the allowable under thickness tolerance.

3.13.3 (1/7/2017)

Surface finish requirement shall be in accordance with the relevant requirements in [2].

3.13.4 (1/7/2017)

Surface inspection is the responsibility of the manufacturer. The acceptance by the Society's Surveyor of material later found to be defective is not to absolve the manufacturer of this responsibility.

3.14 Internal Soundness

3.14.1 (1/7/2017)

Verification of internal soundness is the responsibility of the manufacturer. The acceptance by the Society's Surveyor is not to absolve the manufacturer of this responsibility.

3.14.2 Ultrasonic examination (1/7/2017)

For specific applications, ultrasonic examination in accordance with recognised standards may be required.

3.15 Stress relieving heat treatment and other heat treatments

3.15.1 (1/7/2017)

With respect to Heat Treatment, steels produced by approved manufacturers are suitable for stress relieving heat treatment such as post-weld heat treatment and stress relieving heat treatment after cold forming for the purpose of reducing the risk of brittle fracture, increasing the fatigue lifetime and dimensional stability for machining.

Note 1: Products can be susceptible to deterioration in mechanical strength and toughness if they are subjected to incorrect post-weld

heat treatment procedures or other processes involving heating such as flame straightening, rerolling, etc. where the heating temperature and the holding time exceed the limits given by the manufacturer.

3.16 Facilities for Inspection

3.16.1 (1/7/2017)

Testing is to be carried out under the witness of the Surveyor in order to verify whether the test results meet the specified requirements.

3.16.2 (1/7/2017)

The manufacturer is to afford the Surveyor all necessary facilities and access to all relevant parts of the steel works to enable him to verify the approved process is adhered to, for the selection of test materials, and the witnessing of tests, as required by this Article. Also for verifying the accuracy of the testing, calibration of inspection equipment and traceability of materials.

3.17 Identification of Materials

3.17.1 (1/7/2017)

The manufacturer is to adopt a system for the identification of ingots, slabs, billet or bloom and finished products, which will enable the material to be traced to its original cast. The Surveyor is to be given full facilities for so tracing the material when required.

3.18 Branding

3.18.1 (1/7/2017)

Each finished piece is to be clearly marked by the manufacturer with the following particulars:

- a) Classification Society's brand mark
- b) Unified identification mark for the grade of steel (e.g. EH620)
- c) Name or initials to identify the steelworks
- d) Cast number/Heat number, plate number or equivalent identification mark
- e) Delivery condition (N/NR, TM/TM+AcC/TM+DQ or Q&T)

The entire markings are to be encircled with paint or otherwise marked so as to be easily recognised. Steels which have been specially approved by the Society and which differ from these requirements (see [3.4.6]) are to have the letter "S" after the identification mark (e.g. EH620S).

3.19 Documentation of Inspection Tests

3.19.1 (1/7/2017)

The Surveyor is to be supplied with two copies of the test certificates or shipping statements for all accepted materi-

als. In addition to the description, dimensions, etc., of the material, the following particulars are to be included:

- a) Purchaser's order number
- b) Identification of the cast and piece
- c) Manufacturer's identification
- d) Identification of the grade of steel
- e) Chemical analysis, Ceq, CET or Pcm value
- f) Delivery condition with heat treatment temperatures
- g) Mechanical properties test results, including traceable test identification
- h) Surface quality and inspection results
- i) UT result, where applicable.

3.19.2 (1/7/2017)

Before the test certificates are signed by the Surveyor, the steelmaker is required to provide a written declaration stating that the material has been made by an approved process, and that it has been subjected to and has withstood satisfactorily the required tests in the presence of the Surveyor, or an authorised deputy. The following form of declaration will be accepted if stamped or printed on each test certificate with the name of the steelworks and signed by an authorised representative of the manufacturer:

"We hereby certify that the material has been made by an approved process and has been satisfactorily tested in accordance with the RINA Rules".

4 Steels for boilers and pressure vessels

4.1 Application

4.1.1 The requirements of this Article apply to weldable ferritic steel products (plates, flats, sections and bars) intended for boilers and pressure vessels.

Provision is made for products with thickness up to 60 mm and impact properties at a temperature not lower than -20°C.

These requirements may also be applied to products with thickness above 60 mm subject to agreement with the Society.

4.1.2 Special requirements may be specified in the case of applications intended for dangerous substances or particularly severe service conditions.

4.1.3 In the case of applications involving the storage and transport of liquefied gases, the relevant requirements of Pt E, Ch 9, Sec 6 of the Rules apply.

4.2 Steel grades

4.2.1 The requirements apply to carbon and carbon manganese steels and low alloy steels (Mo and Cr-Mo steels).

4.2.2 Carbon and carbon manganese steels are classed into four groups indicated by the minimum ultimate tensile strength R_m (N/mm²): 360, 410, 460 and 510.

Each group may be further subdivided into grades HA, HB and HD, as appropriate, based on the quality level and impact properties.

The letters HA, HB and HD mean impact properties at +20°C, 0°C and -20°C, respectively.

4.2.3 Low alloy steels are designated according to the chemical composition into the grades 0,3Mo - 1Cr0,5Mo - 2,25Cr1Mo.

Two types of 2,25Cr1Mo steel are specified in relation to the heat treatment and consequent mechanical properties.

The figures mean the nominal percentage content of the main alloying elements.

4.3 Manufacture

4.3.1 Approval

Unless otherwise agreed by the Society, the Manufacturers are to be approved and the relevant requirements of [1.2] apply.

4.3.2 Deoxidation process

The method of deoxidation is specified in Tab 16 and Tab 17.

4.3.3 Dimensional tolerances

Minus tolerances on the thickness are not normally permitted.

4.3.4 Rectification of surface defects by grinding

Surface defects may generally be removed by grinding as indicated in [1.6.1], provided that the thickness, after grinding, is not less than the nominal thickness.

However the extent of repairs is to be agreed with the Surveyor. Where the thickness is reduced below the nominal thickness given in the approved plans, the possible acceptance and the relevant conditions are subject to special consideration by the Society.

4.3.5 Rectification of surface defects by welding

Defects which cannot be removed by grinding may generally be repaired by welding under the conditions given in [1.6.2], except that suitable heat treatment and non-destructive examination are always required after repair.

The purchaser is to be informed as to the extent and position of the repairs carried out on the individual plates.

4.4 Condition of supply

4.4.1 The products are to be supplied in the conditions indicated in Tab 18 for carbon and carbon manganese steels and Tab 19 for low alloy steels.

4.4.2 The products to be processed after supply by hot forming may also be supplied, where agreed, in the as rolled condition.

In such cases heat treatment is to be carried out after hot forming and provision for the mechanical tests indicated in [4.8.4] is to be made.

4.5 Chemical composition

4.5.1 The chemical composition on ladle analysis is to comply with the requirements specified in Tab 16 for carbon and carbon manganese steels and Tab 17 for low alloy steels and/or in the approved specification.

The approved specification is also to include the alloying and grain refining elements (not specified in the above-mentioned Tables).

The relevant elements as applicable are to be stated by the steelmaker and included in the testing documentation for each cast.

For C and C-Mn steels, an upper limit for carbon equivalent C_{EQ} on the ladle analysis may be specified at the time of approval of the individual steels.

Unless otherwise agreed, the value of C_{EQ} is calculated by the following formula:

$$C_{EQ} = C + \frac{Mn}{6} + \frac{Cr + Mo + V}{5} + \frac{Ni + Cu}{15} \quad \%$$

Unless otherwise agreed, when a limit for C_{EQ} is required, the relevant values are to be stated by the steel-maker and included in the testing documentation for each cast.

4.6 Mechanical properties

4.6.1 The mechanical properties are specified in Tab 18 for carbon and carbon manganese steels and Tab 19 for low alloy steels.

Table 16 : Carbon and carbon manganese steels - Chemical composition

Steel grade	Deoxidation	Chemical composition (%) (1)						
		C max	Mn	Si	P max	S max	Al tot. min. (1)	Ni max
360HA	not rimmed	0,16	≥ 0,40	≤ 0,35	0,030	0,030		
360HB	killed	0,16	0,40 - 1,20	0,10 - 0,35	0,030	0,030		
360HD	killed and fine grained	0,16	0,40 - 1,20	0,10 - 0,35	0,030	0,030	0,020	
410HA	not rimmed	0,20	≥ 0,50	≤ 0,35	0,030	0,030		0,30
410HB	killed	0,20	0,50 - 1,40	0,10 - 0,35	0,030	0,030		0,30
410HD	killed and fine grained	0,20	0,50 - 1,40	0,10 - 0,35	0,030	0,030	0,020	0,30
460HB	killed	0,20	0,80 - 1,50	0,10 - 0,40	0,030	0,030		0,30
460HD	killed and fine grained	0,20	0,80 - 1,50	0,10 - 0,40	0,030	0,030	0,020	0,30
510HB	killed	0,22	0,90 - 1,60	0,10 - 0,50	0,030	0,025		0,30
510HD	killed and fine grained	0,20	0,90 - 1,60	0,10 - 0,50	0,030	0,025	0,020	0,30

(1) Nb, V or Ti may be used for grain refining as a complete or partial substitute for Al. The grain refining elements are to be specified at the time of approval; in general Nb and V are not to exceed 0,05 and 0,10%, respectively.
Additional alloying elements are to be submitted for consideration and approval. Residual elements not intentionally added are not to exceed the following limits:
Cu ≤ 0,30% ; Cr ≤ 0,25% ; Mo ≤ 0,10% . Total : Ni + Cu + Cr + Mo ≤ 0,70%

Table 17 : Low alloy steels - Chemical composition

Steel grade	Deoxidation (2)	Chemical composition (%) (1)						
		C	Mn	Si	P max	S max	Cr	Mo
0,3Mo	Si killed	0,12 - 0,20	0,40 - 0,90	0,10 - 0,35	0,030	0,030	≤ 0,30	0,25-0,35
1Cr 0,5Mo	Si killed	0,08 - 0,18	0,40 - 1,00	0,15 - 0,35	0,030	0,030	0,70-1,20	0,40-0,60
2,25Cr 1Mo	Si killed	0,07 - 0,15	0,40 - 0,80	0,15 - 0,50	0,030	0,030	2,00-2,50	0,90-1,10

(1) Residual elements are not to exceed the following limits: Cu ≤ 0,30%, Ni ≤ 0,30% .
(2) Aluminium total max 0,020% for all grades of steel. The aluminium content is to be mentioned in the ladle analysis certificate.

Table 18 : Carbon and carbon manganese steels - Mechanical properties

Steel grade	Heat treatment (1)	Yield stress R _{eH} (N/mm ²) min. for thickness (mm)			Tensile strength R _m (N/mm ²)	Elong.A ₅ (%) min.	Average impact energy (J) min.		
		t ≤ 16	16 < t ≤ 40	40 < t ≤ 60			Test temp (°C)	KVT	KVL
360HA	N or NR	215	205	195	360 - 480	25	+ 20	27	41
360HB		235	225	215			0		
360HD							- 20		
410HA	N or NR	245	235	225	410 - 530	23	+ 20		
410HB		265	255	245			0		
410HD							- 20		
460HB	N or NR	285	270	260	460 - 580	22	0		
460HD		295	285	280			- 20		
510HB	N or NR	345	335	325	510 - 630	21	0		
510HD		355	345	335			-20		

(1) N : Normalising - NR : Normalising Rolling. As an alternative to normalising, the as rolled condition may be accepted for sections, subject to approval of individual steelmakers.

Table 19 : Low alloy steels - Mechanical properties

Steel grade	Heat treatment (1)	Yield stress R_{eH} (N/mm ²) min. for thickness (mm)			Tensile strength R_m (N/mm ²)	Elongation A_5 (%) min. for thickness (mm)		Average impact energy (J) min. at +20°C KVT
		$t \leq 16$	$16 < t \leq 40$	$40 < t \leq 60$		$t \leq 40$	$40 < t \leq 60$	
0,3Mo	N	275	270	260	430 - 600	24	23	31
1Cr 0,5Mo	N + T	300	295	295	450 - 610	20	19	
2,25Cr 0,5Mo	N + T	295	285	275	520 - 670	18	18	
	N+T or Q+T	310	310	310	470 - 620			

(1) N = Normalising; T = Tempering; Q = Quenching

4.7 Mechanical properties at elevated temperatures

4.7.1 The values for the yield stress or 0,2% proof stress ($R_{p0,2}$) at temperatures of 100°C and higher are given in Tab 20.

The above values are for design purposes only. Their verification is in general not required during the testing, unless figures higher than those shown in the above Tables but in accordance with recognised standards are proposed by the steel Manufacturer.

In such cases, the verification is required and the procedures detailed in [4.7.2] and [4.7.3] are to be followed.

4.7.2 When $R_{p0,2}$ is required to be verified, at least one tensile test for each cast is to be carried out at the agreed temperature.

The sample is to be cut from the thickest plate of the cast and, if applicable, at the end of the plate that has shown the lowest figures in the tensile test at ambient temperature.

The sample is to be taken halfway between the edge and the axis of the piece, and the axis of the test specimen is to be located at one quarter of the thickness from one of the rolled surfaces.

The dimensions of the specimens and the testing procedure are to be in accordance with the requirements of Ch 1, Sec 2, [2.1] and Ch 1, Sec 2, [2.2.5], respectively.

The results of tests are to comply with the specified values.

4.7.3 As an alternative to the systematic verification of the required $R_{p0,2}$ as in [4.7.2], it may be agreed with the individual steelmakers to carry out an adequate program of tests on the normal production for each type of steel to be approved.

For Manufacturers and steel types approved on this basis, tensile tests at elevated temperatures are not generally required during the routine testing of the material supplied; they may be required by the Society as a random check for the confirmation of the approval.

4.7.4 For design purposes only, the estimated values of the stress to rupture in 100000 hours are given in Tab 21 for groups of steels.

4.8 Mechanical tests

4.8.1 General

Unless otherwise agreed (see [4.8.6]), samples for tests are to be cut from the products in the final supply conditions.

4.8.2 Samples from plates and wide flats

One sample is to be taken from one end of each rolled unit when the mass and the length do not exceed 5t and 15m, respectively.

When either of these limits is exceeded, samples are to be cut at both ends of each rolled unit.

The definition of rolled unit is given in Ch 1, Sec 1, [3.3.3].

4.8.3 Samples from sections and bars

One sample is to be taken from each batch homogeneous for cast, section size and condition of supply. Each batch is to contain not more than 50 pieces and its total mass is not to exceed 10 t.

4.8.4 Sampling of test specimens

In the case of plates and wide flats having width ≥ 600 mm, the tensile test and impact test specimens are to be taken in the transverse direction.

In other cases the specimens are to be taken in the longitudinal direction, unless otherwise required by or agreed with the Society.

4.8.5 Number of test specimens

The following test specimens are to be taken from each sample:

- 1 tensile test specimen (2 tests in the case of bars intended for tie rods)
- 1 set of 3 Charpy V-notch impact test specimens (only for grades HB and HD unless otherwise specified)
- 1 tensile test specimen at elevated temperature, for each cast, when required.

Table 20 : Minimum proof stress ($R_{p0,2}$) values at elevated temperatures

Steel grade	Thickness (mm)	$R_{p0,2}$ (N/mm ²) at a temperature (°C) of										
		100	150	200	250	300	350	400	450	500	550	600
360HA (1)	≤ 16	175	172	168	150	124	117	115				
	> 16 ≤ 40	171	169	162	144	124	117	115				
	> 40 ≤ 60	162	158	152	141	124	117	115				
360HB (1) 360HD (1)	≤ 16	204	185	165	145	127	116	110				
	> 16 ≤ 40	196	183	164	145	127	116	110				
	> 40 ≤ 60	179	172	159	145	127	116	110				
410HA (1)	≤ 16	211	208	201	180	150	142	138				
	> 16 ≤ 40	201	198	191	171	150	142	138				
	> 40 ≤ 60	192	188	181	168	150	142	138				
410HB (1) 410HD (1)	≤ 16	235	216	194	171	152	141	134				
	> 16 ≤ 40	228	213	192	171	152	141	134				
	> 40 ≤ 60	215	204	188	171	152	141	134				
460HB (1) 460HD (1)	≤ 16	262	247	223	198	177	167	158				
	> 16 ≤ 40	260	242	220	198	177	167	158				
	> 40 ≤ 60	251	235	217	198	177	167	158				
510HB (1) 510HD (1)	≤ 60	290	270	255	235	215	200	180				
0,3Mo	≤ 60			215	200	170	160	150	145	140		
1Cr 0,5Mo	≤ 60			230	220	205	190	180	170	165		
2,25Cr 1Mo	≤ 60 (2)			235	230	220	210	200	190	180		
	≤ 60 (3)			265	255	235	225	215	205	195		

(1) The values at $R_{p0,2}$ for temperatures ≤ 250°C are for guidance only.
(2) Normalised and tempered
(3) Normalised and tempered or quenched and tempered

4.8.6 Material to be hot worked

When for material to be hot worked after delivery, it is agreed that the heat treatment required will be carried out by the purchaser, the samples are to be submitted by the steelmaker to such treatment before the cutting of test specimens.

In particular cases (when the material is submitted to cold or hot working during fabrication), tests additional to the routine testing may be required on samples in the final condition of the material after fabrication.

These may also include tests on material submitted to artificial aging treatment as indicated in Ch 1, Sec 2, [8.1.1].

5 Ferritic steels for low temperature service

5.1 Application

5.1.1 The requirement of this Article apply to ferritic steel products (plates, flats, sections and bars) intended for cargo tanks, storage tanks, process pressure vessels and systems for liquefied gases and other pressure vessels in general, when impact properties at temperature lower than -20°C are required.

Provision is made for products with thickness up to 60mm.

The extension to higher thicknesses and relevant conditions are subject to agreement with the Society.

5.1.2 Special requirements may be specified in the case of applications intended for dangerous substances or particularly severe service conditions.

5.1.3 In case of applications involving the storage and transport of liquefied gases, the appropriate requirements of Pt E, Ch 9, Sec 6 also apply.

5.2 Steel grades

5.2.1 The requirements apply to carbon, carbon manganese and Ni alloy steels.

5.2.2 The carbon and carbon manganese steels are classed into four groups indicated by the minimum ultimate tensile strength R_m (N/mm²): 410, 460, 510 and 550.

Each group is further subdivided into two grades, LE and LF, based on the quality level and impact properties.

The letters LE and LF mean impact properties at -40 and -60°C, respectively.

5.2.3 Ni alloy steels are designated according to the chemical composition into the grades: 1,5Ni - 3,5Ni - 5Ni - 9Ni. The figures mean the Ni nominal percentage content.

Table 21 : Average values for stress to rupture in 100000 hours (N/mm²)

Temperature (°C)	Steel grade				
	360 - 410	460 - 510	0,3Mo	1Cr 0,5Mo	2,25Cr 1Mo
380	170	225			
390	155	200			
400	140	175			
410	125	155			
420	110	135			
430	100	115			
440	90	100			
450	75	85	235	285	220
460	(60)	(70)	205	250	205
470	(50)	(60)	175	220	185
480	(40)	(55)	145	190	170
490		(45)	120	160	150
500		(40)	100	135	135
510			80	120	120
520			65	95	105
530			50	80	90
540				60	75
550				50	65
560				40	55
570				30	50
580					45
590					(40)
600					(35)

Note 1: The values shown are estimated average values; the lower limit of the range is approximately 20% less than the average value. The values in brackets for some higher temperatures indicate that the steel is not suitable for continuous use at such temperatures.

5.3 Manufacture

5.3.1 Approval

The Manufacturers are to be approved by the Society (see [1.2]).

5.3.2 Deoxidation process

The steel is to be killed and fine grained.

5.3.3 Dimensional tolerances

For pressure vessels, minus tolerances on thickness are not normally permitted.

5.3.4 Surface conditions

For repairs, the provisions of [4.3.4] and [4.3.5] apply.

Repairs by welding are not normally allowed on 5% or 9% nickel steels.

5.4 Condition of supply

5.4.1 Unless otherwise accepted by the Society, carbon and carbon manganese products are to be supplied in normalised (N) condition.

Nickel steel products are to be supplied in the conditions indicated in Tab 25.

5.4.2 The products to be processed after supply by hot working may also be supplied, where agreed, in the as rolled condition.

In such cases heat treatment is to be carried out after forming and provision for the mechanical tests indicated in [4.8.6] is to be made.

5.5 Chemical composition

5.5.1 The chemical composition on ladle analysis is to comply with the requirements specified in Tab 22 and Tab 23 and/or in the approved specification .

The approved specification is also to include the alloying and grain refining elements (not specified in Tab 22).

The content of the above elements, as applicable, is to be stated by the steelmaker for each heat and included in the testing documentation.

For C and C-Mn steels, an upper limit for carbon equivalent C_{EQ} on the ladle analysis may be specified at the time of approval of the individual steels.

Unless otherwise agreed, the value of C_{EQ} is calculated by the following formula:

$$C_{EQ} = C + \frac{Mn}{6} + \frac{Cr + Mo + V}{5} + \frac{Ni + Cu}{15} \quad \%$$

Unless otherwise agreed, when a limit for C_{EQ} is required the relevant values are to be stated by the steelmaker and included in the testing documentation for each cast.

5.6 Mechanical properties

5.6.1 The products are to comply with the mechanical properties specified in Tab 24 and Tab 25.

5.7 Mechanical tests

5.7.1 General

Unless otherwise agreed in the case of materials to be hot worked after delivery [5.4.2], samples for tests are to be cut from the products in the final supply conditions.

5.7.2 Plates and wide flats

One sample is to be taken from one end of each rolled unit when the mass and the length do not exceed 5t and 15m, respectively.

When either of these limits is exceeded, samples are to be cut at both ends of each rolled unit.

The definition of rolled unit is given in Ch 1, Sec 1, [3.3.3].

Table 22 : Carbon and carbon manganese steels - Chemical composition

Steel grade	Chemical composition (%) (1)						
	C max	Mn	Si	P max	S max	Al tot min	Ni max
410 LE	0,18	0,50 - 1,40	0,10 - 0,35	0,030	0,030	0,020	0,30
410 LF	0,16	0,50 - 1,40	0,10 - 0,35	0,030	0,030	0,020	0,80
460 LE	0,18	0,80 - 1,50	0,10 - 0,40	0,030	0,030	0,020	0,30
460 LF	0,16	0,80 - 1,50	0,10 - 0,40	0,030	0,030	0,020	0,80
510 LE	0,18	1,00 - 1,70	0,10 - 0,50	0,030	0,025	0,020	0,30
510 LF	0,16	1,00 - 1,70	0,10 - 0,50	0,030	0,025	0,020	0,80
550 LE	0,18	1,00 - 1,70	0,10 - 0,50	0,030	0,025	0,020	0,30
550 LF	0,16	1,00 - 1,70	0,10 - 0,50	0,030	0,025	0,020	0,80

(1) Nb, V or Ti may be used for grain refining as a complete or partial substitute for Al. The grain refining elements are to be specified at the time of approval; in general Nb and V are not to exceed 0,05 and 0,10 %, respectively. Additional alloying elements are to be submitted for consideration and approval. Residual elements not intentionally added are not to exceed the following limits (%): Cu ≤ 0,30, Cr ≤ 0,15, Mo ≤ 0,10.

Table 23 : Nickel alloy steels - Chemical composition

Steel grade	Chemical composition (1) (2)							
	C max	Mn	Si max	P max	S max	Ni	Cr max	Mo max
1,5 Ni	0,18	0,30 - 1,50	0,35	0,035	0,020	1,30 - 1,70	0,25	0,10
3,5 Ni	0,15	0,30 - 0,90	0,35	0,035	0,020	3,20 - 3,80	0,25	0,10
5,0 Ni	0,12	0,30 - 0,90	0,35	0,035	0,020	4,70 - 5,30	0,25	0,10
9,0 Ni	0,10	0,30 - 0,90	0,35	0,035	0,020	8,50 - 10,0	0,25	0,10

(1) Residual elements are not to exceed the following limits (%): Cu ≤ 0,35 ; V ≤ 0,05 . Total Cr + Cu + Mo ≤ 0,50
 (2) Aluminium total not less than 0,020 for all grades of steels. The aluminium content is to be mentioned in the ladle analysis certificate.

Table 24 : Carbon and carbon manganese steels - Mechanical properties

Steel grade	Yield stress R_{eH} (N/mm ²) min. for thickness t (mm)			Tensile strength R_m (N/mm ²)	Elong. A_5 (%) min	Average impact energy (J) min.		
	t ≤ 16	16 < t ≤ 40	40 < t ≤ 60			Temp (°C)	KVT	KVL
410 LE	265	255	245	410 - 530	23	-40	27	41
410 LF	290	280	270	410 - 530	23	-60	27	41
460 LE	295	285	270	460 - 580	22	-40	27	41
460 LF	320	310	300	460 - 580	22	-60	27	41
510 LE	355	345	335	510 - 630	21	-40	27	41
510 LF	355	345	335	510 - 630	21	-60	27	41
550 LE	390	380	375	550 - 670	20	-40	27	41
550 LF	390	380	375	550 - 670	20	-60	27	41

Table 25 : Nickel steels - Mechanical properties

Steel grade	Heat treatment (1)	Yield stress R_{eH} (N/mm ²) min.	Tensile strength R_m (N/mm ²)	Elongation A_5 (%) min.	Average impact energy (J) min.		
					Temp (°C)	KVT	KVL
1,5 Ni	N+T or Q+T	275	490 - 640	22	-80	27	41
3,5 Ni	N+T or Q+T	285	450 - 610	21	-95	27	41
5,0 Ni	N+T or Q+T	390	540 - 740	21	-110	27	41
9,0 Ni	N+N+T or Q+T	490	640 - 790	18	-196	27	41

(1) N=normalising T= tempering Q = quenching

5.7.3 Sections and bars

One sample is to be taken from each batch homogeneous for heat, section size and condition of supply.

Each batch is to contain not more than 50 pieces and its total mass is not to exceed 10 t.

5.7.4 Sampling

In the case of plates and wide flats having width ≥ 600mm, the tensile test and impact test specimens are to be taken in the transverse direction.

In other cases the specimens are to be taken in the longitudinal direction, unless otherwise required by or agreed with the Society.

5.7.5 Number of tests

The following test specimens are to be taken from each sample:

- 1 tensile test specimen
- 1 set of 3 Charpy V-notch impact test specimens
- 2 or more drop weight test specimens, when required.

6 Steels for machinery

6.1 Application

6.1.1 The requirements of this Article apply to carbon, carbon manganese, low alloy and alloy rolled steel products intended for use in the construction of structures and parts

of machinery and equipment operating at ambient temperature.

In the case of applications in low or high temperature pressure systems, reference is to be made to the applicable requirements of Articles [5] and [4] respectively.

6.1.2 The products are grouped as follows, depending on the application:

- structural parts of deck equipment
- welded machinery structures such as bedplates, crank-cases, frame entablatures or similar items
- rolled products, such as bars for small shafts, pins, bolts or similar items, when, in the limit of diameters of 250mm, they are accepted in lieu of forgings.

6.2 Steel grades and relevant properties

6.2.1 The type of steels covered by Articles [2], [4], [5] and [7] may be used as appropriate.

Chemical and mechanical properties are to comply with the requirements given therein.

For products having thickness exceeding the maximum thickness considered in the above-mentioned Articles, the following deviations in mechanical properties are permitted:

- the minimum yield stress R_{eH} required is reduced by 1% for every 5 mm thickness over the a.m. maximum

- the minimum elongation A_5 min. required is reduced by 1 unit for thickness over than the a.m. max up to 100 mm and by 2 units for thickness greater than 100 mm.

6.3 Manufacture and condition of supply

6.3.1 Products intended for applications under [6.1.2] a) and [6.1.2] b) are to be manufactured and supplied as indicated in [2.3] and [2.4], [4.3] and [4.4], [5.3] and [5.4], as appropriate.

For products intended for applications under [6.1.2] c), the applicable requirements of Sec 3 apply; unless otherwise agreed, a reduction ration of 6:1 in respect of the original ingot is generally required.

6.3.2 For specific applications, ultrasonic examinations in accordance with approved standards or procedures may be required.

Rolled bars for shaft lines, used in lieu of forgings and having a diameter higher than 150 mm, are to be submitted to non-destructive (ultrasonic and magnetoscopic) examinations.

6.3.3 (1/7/2019)

The minus tolerances on nominal thickness for plates and wide flats for machinery structures are to be in accordance with Tab 26.

Measurements are to be made as indicated in [2.3.3].

The plus tolerances on nominal thickness are to be in accordance with a recognised national or international standard, unless required otherwise by the Society or purchaser.

Table 26 : Minus tolerances on nominal thickness for products for machinery structures (1/7/2019)

Nominal thickness t (mm)	Minus tolerance on nominal thickness (mm)
$3 \leq t < 5$	- 0,3
$5 \leq t < 8$	- 0,4
$8 \leq t < 15$	- 0,5
$15 \leq t < 25$	- 0,6
$25 \leq t < 40$	- 0,7
$40 \leq t < 80$	- 0,9
$80 \leq t < 150$	- 1,1
$150 \leq t < 250$	- 1,2
$t \geq 250$	- 1,3

6.4 Mechanical tests

6.4.1 For applications under [6.1.2] a) and [6.1.2] b), irrespective of the grade of steel, the testing may be in batches in accordance with the relevant requirements of Article [2].

One tensile test is to be carried out from one piece for each batch presented or fraction thereof.

Unless otherwise required, the impact tests may be omitted.

6.4.2 For applications under [6.1.2] c), the testing procedure is to be in accordance with the requirements of Sec 3, [1.11.4] relevant to forgings.

6.4.3 The results of tensile and impact tests are to comply with requirements of Articles [2], [4] and [5], [7], as applicable.

7 Stainless steel products

7.1 Application

7.1.1 The requirements of this Article apply to austenitic and austenitic-ferritic (duplex) rolled stainless products intended for use in construction of cargo tanks, storage tanks and pressure vessels for chemicals and limitedly to the austenitic grades for liquefied gases.

7.1.2 Austenitic stainless steels are suitable for use both at elevated and low temperatures.

When austenitic stainless steels are proposed for use at elevated temperatures, details of chemical composition, heat treatment and mechanical properties are to be submitted for consideration and approval.

Unless otherwise specified, austenitic-ferritic stainless steels are in general suitable for service temperature between -20°C and +275°C.

7.1.3 Stainless steel bars may be used for propeller shafts or similar applications under the conditions given in [6.1.2] c).

7.1.4 In cases of applications involving the storage and transport of liquefied gases in bulk, the appropriate requirements of Pt E, Ch 9, Sec 6 apply.

7.2 Steel grades

7.2.1 The requirements apply to Cr-Ni austenitic and austenitic-ferritic stainless steels.

Note 1: Reference is made for designation to the corresponding AISI grade.

Other stainless steel of martensitic types, in accordance with international or national standards, may be accepted for specific applications such as in [7.1.3].

7.3 Manufacture

7.3.1 Approval

Unless otherwise agreed, the Manufacturers of steel intended for the construction of chemical carriers are to be approved by the Society and the relevant requirements of [1.2] apply.

7.3.2 Corrosion resistance

The resistance of tank material to cargoes is under the responsibility of the yard.

Justification of such resistance is to be submitted to the Society.

7.3.3 Dimensional tolerances

With the exception of pressure vessels (see [4.3.3]), the minimum tolerance on thickness is to be 0,3 mm.

7.3.4 Surface conditions

Surface defects may be removed by grinding, provided that the plate thickness at the location of the ground zone is not less than the minimum thickness specified in [7.3.3].

Surface defects which cannot be removed by grinding may be generally repaired under the conditions given in [2.3.7], as applicable.

7.4 Condition of supply

7.4.1 All materials are to be supplied in the solution treated condition.

7.5 Chemical composition

7.5.1 The chemical composition on ladle analysis is to comply with the requirements specified in Tab 27.

7.6 Mechanical properties

7.6.1 The mechanical properties are specified in Tab 28.

7.7 Mechanical tests

7.7.1 Batch composition

The products are grouped in batches of 20 tons or fraction thereof, consisting of parts coming from the same cast, the thickness of which differs by no more than 5mm in the case of flat products.

When the batch is made up of plates, the plate selected to take the test specimens is to be one of those of highest thickness.

7.7.2 Sampling

In the case of plates and wide flats having width ≥ 600 mm, the tensile test and impact test specimens are to be taken in the transverse direction.

In other cases the specimens are to be taken in the longitudinal direction, unless otherwise required by or agreed with the Society.

7.7.3 Number of tests

The following tests are to be carried out:

- a) one tensile test at ambient temperature
- b) unless otherwise required, 3 Charpy V-notch impact tests at :
 - -196°C for austenitic steels intended for use in constructions with design temperature lower than -105°C
 - -20°C for austenitic-ferritic steels.

Table 27 : Chemical composition

AISI grade designation	Chemical composition (%) (1)								
	C max	Mn max	Si max	P max	S max	Cr	Ni	Mo	Others
Austenitic									
304 L	0,030	2,0	1,0	0,040	0,030	17,0 - 19,0	9,0 - 12,0	-	
304 LN	0,030	2,0	1,0	0,040	0,030	17,0 - 19,0	8,5 - 11,0	-	0,14 ≤ N ≤ 0,22
316 L	0,030	2,0	1,0	0,040	0,030	16,0 - 18,5	10,0 - 14,0	2,0 - 3,0	
316 LN	0,030	2,0	1,0	0,040	0,030	16,0 - 18,5	11,0 - 13,0	2,0 - 3,0	0,14 ≤ N ≤ 0,22
317 L	0,030	2,0	1,0	0,040	0,030	18,0 - 20,0	14,0 - 16,0	3,0 - 4,0	
317 LN	0,030	2,0	1,0	0,040	0,030	18,0 - 20,0	12,5 - 14,0	3,0 - 4,0	0,14 ≤ N ≤ 0,22
321	0,080	2,0	1,0	0,040	0,030	17,0 - 19,0	9,0 - 13,0	-	5xC ≤ Ti ≤ 0,80
347	0,080	2,0	1,0	0,040	0,030	17,0 - 19,0	9,0 - 13,0	-	10xC ≤ Nb ≤ 0,80
Duplex austenitic-ferritic									
UNS S 31803	0,030	2,0	0,75	0,035	0,010	21,0 - 23,0	4,5 - 6,5	2,5 - 3,0	0,10 ≤ N ≤ 0,22
UNS S 32550	0,030	2,0	0,75	0,035	0,010	24,0 - 26,0	5,5 - 7,5	2,7 - 3,9	1,0 ≤ Cu ≤ 2,0
UNS S 32750	0,030	2,0	0,80	0,035	0,020	24,0 - 26,0	6,0 - 8,0	3,0 - 5,0	Cu ≤ 0,50
(1) Additional alloying elements are to be submitted for consideration and approval. Residual elements are permitted provided they do not impair the properties, subsequent processing or behaviour in service of the material.									

Table 28 : Mechanical properties

AISI grade designation	Yield strength (N/mm ²) min. (1)		Tensile strength R _m (N/mm ²)	A ₅ (%) min.	Average impact energy (J) min.	
	R _{p0.2}	R _{p1.0}			KVL	KVT
Austenitic					at -196°C	at -196°C
304 L	175	215	470 - 670	45	41	27
304LN	270	310	570 - 790	40		
316L	195	235	490 - 690	45		
316LN	300	340	≥ 590	45		
317L	195	235	490 - 690	40		
317LN	300	340	≥ 590	45		
321	205	245	500 - 750	40		
347	205	245	500 - 750	40		
Duplex austenitic-ferritic						
UNS S31803	≥ 470		660 - 800	25	41	27
UNS S32550	≥ 490		690 - 890	25		
UNS S32750	≥ 530		730 - 930	25		
(1) The yield strength R _{p0.2} is in general to be determined						

7.8 Metallographic structure inspection

7.8.1 When required, a metallographic structure inspection is to be carried out on sections parallel to the rolling direction of the product, and taken over the whole thickness of the product.

The inspection is to be performed with magnification 200x.

No detrimental intermetallic phase (sigma phase) is to appear in appreciable quantity.

7.9 Intergranular corrosion test

7.9.1 When required, an intergranular corrosion test is to be carried out in compliance with standard ASTM A262 Practice E, or other recognised standards.

The test is to reveal no sensitivity to intergranular corrosion.

7.10 Through thickness tests

7.10.1 Where improved through thickness ductility is required, through thickness tests are to be performed; through thickness tests are generally not required for grades 304L, 304LN, 321 and 347.

7.10.2 Tests and results are to be in accordance with the requirements of Article [9] and [7.10.3].

7.10.3 When the reduction in area is between 25 and 35 per cent, additional metallographic examination or other evidence is required to show that no significant amount of any detrimental phase, such as sigma, is present.

8 Clad steel plates

8.1 Application

8.1.1 The requirements of this Article apply to clad steel plates consisting of a base material "backing steel" and a thinner stainless steel layer "cladding steel" on one or both sides, continuously and integrally bonded, by hot rolling or by explosion bonding.

Provision is made for plates having total thickness higher than 5mm; unless otherwise accepted by the Society, the thickness of the cladding metal is to be ≥ 2mm.

8.2 Steel grades

8.2.1 The grade of the backing steel is to be chosen from the steel grades for boilers and pressure vessels defined in Article [4].

Other backing steel grades may be accepted subject to the Society's approval.

8.2.2 The cladding metal in austenitic or austenitic-ferritic stainless steel is to correspond to the grades defined in Article [7].

The use of other grades for stainless steel cladding is to be proposed to the Society for prior approval.

8.3 Manufacture

8.3.1 Approval

Clad steel plate Manufacturers are to be approved by the Society and the conditions for approval are indicated in the document "Approval of Manufacturers".

8.3.2 Surface condition and dimensional tolerances

The surface condition of the cladding steel is to be in conformity with the specifications of the order.

The Manufacturer is responsible for the inspection of the surface condition, as well as the compliance with the dimensions and the tolerances. However, as the cladding surface condition is important for the corrosion resistance, this inspection of the surface condition carried out by the Manufacturer may be double-checked by a thorough examination made by the Surveyor on the cladding surface.

8.4 Condition of supply

8.4.1 The plates are to be supplied in the same heat treatment condition as stated during the approval.

8.5 Chemical composition

8.5.1 Works' certificates for backing and cladding steels stating the chemical composition are to be supplied by the Manufacturer.

8.6 Mechanical properties

8.6.1 The mechanical properties of the backing material are to comply with the requirements given in Article [4].

The check of the mechanical properties of the cladding material is not required.

8.7 Mechanical tests

8.7.1 Batch composition

The batch is to be composed of plates having the same overall thickness, cladding thickness and cast of backing steel, and mass not exceeding 20 t.

8.7.2 Number of tests

The following tests are to be performed:

- 1 tensile test on the full clad plate
- 2 bend tests on the the full clad plate
- 1 series of impact tests on the backing steel
- 1 shear test on the cladding.

8.7.3 Tensile test

During the tensile test of the full clad plate, the strength is to be not less than the value given by the following formula:

$$R = \frac{R_b \cdot t_b + R_c \cdot t_c}{t}$$

where:

R_b : Nominal minimum R_{eH} or R_m of backing material

R_c : Nominal minimum R_{eH} or R_m of cladding material

t_b : Nominal thickness of backing material

t_c : Nominal thickness of cladding material

t : Nominal thickness of the full clad plate.

If the values resulting from the tensile test (yield stress, ultimate tensile strength) are lower than those given by the

above formula, one additional test is to be performed after removal of the cladding material.

During the tests the requirements for the backing material are to be satisfied.

The value of elongation specified for the backing material applies also to the full clad plate.

8.7.4 Bend tests

The bending conditions (mandrel diameter in general 3 times the plate thickness) are those required for the backing steel grade. One bend test is carried out with the cladding metal on the tensioned side (outer side of bend) and another with the cladding metal on the compressed side (inner side of bend). In the latter test, separations of the cladding not exceeding 25% of the bent portion are admitted.

8.7.5 Shear test

The shear test is carried out in accordance with ASTM A 264. The shear strength is to be at least 140 N/mm².

8.8 Corrosion testing

8.8.1 When required, an accelerated corrosion test is to be carried out to check the resistance of the cladding metal against intergranular corrosion. This corrosion test may be carried out according to a national or an international standard, or to a particular specification, in agreement with the Society. ASTM A 262 practice E may be used.

8.9 Ultrasonic testing

8.9.1 Ultrasonic inspection of the adhesion of the cladding is generally to be performed on plates with an overall thickness (backing + cladding) equal to or greater than 10mm. For overall thickness less than 10mm, the ultrasonic inspection procedure is to be defined in agreement with the Society.

8.9.2 The ultrasonic inspection is to be performed with the following procedures:

- peripheral inspection of a strip of 50mm in width on all the plate edges
- continuous inspection according to a grid with square meshes, 200mm long and parallel to the plate edges.

Random checks may be required by the Surveyor.

8.9.3 The reflection technique is used, with a normal probe having a diameter ranging from 20 to 35 mm and a frequency from 3 to 5 MHz.

8.9.4 Unless otherwise agreed with the Society, non-adhesion areas which do not exceed 50mm x 50mm are tolerated without repair, provided that they are at least 500mm apart.

8.10 Surface defects and repairs

8.10.1 Surface defects may be accepted by the Surveyor when they are not detrimental to the proper use of the product and its corrosion resistance.

8.10.2 All the surface defects are to be ground so as to restore the surface continuity. Nevertheless, such repair by grinding is admitted only if the remaining thickness of the cladding is at least equal to its guaranteed nominal thickness.

8.10.3 In cases where, after grinding, the cladding thickness is less than the guaranteed nominal thickness, the repair is carried out by welding. The filler metal is to be of the same grade as the cladding and the repair procedure is to be defined in agreement with the Surveyor and preliminarily approved.

8.10.4 If, after grinding of the defect, the remaining thickness of the cladding is less than half of the guaranteed nominal thickness, it is necessary to replace the cladding by tapering and to rebuild the whole of the cladding by welding. Such delicate repair is to be carried out in agreement with the Surveyor and preliminarily approved.

8.11 Adhesion defects in the cladding and repairs

8.11.1 In the case of adhesion defects detected by an ultrasonic inspection as defined in [8.9], the areas of non-adhesion of the cladding which exceed the limits specified in [8.9.4] are to be removed by cutting off or to be repaired.

9 Steels with specified through thickness properties

9.1 Application

9.1.1 The requirements of this Article apply to steel plates and wide flats having thickness not less than 15mm, where improved through thickness ductility in the direction of thickness is required (see [1.1.3]).

The extension to lower thicknesses and relevant conditions are at the discretion of the Society.

9.2 Steel grades

9.2.1 (1/7/2003)

The requirements of Article [9] are intended as a supplement to the requirements of Articles [2], [3], [4], [5], [6] and [7] which specify the quality of steels for hull structures, boilers, pressure vessels, low temperature applications and machinery and are intended to have specified minimum ductility in the through thickness or "Z" direction (see Fig 9).

9.2.2 The Z designation is to be given to any steel grade which has been tested according to the above mentioned specifications, and has been successfully subjected to the tests defined in [9.6] and [9.8].

9.2.3 (1/7/2003)

Two "Z" quality steels are specified, Z25 for normal ship applications and Z35 for more severe applications.

Figure 9 : Normal test specimen (1/7/2003)

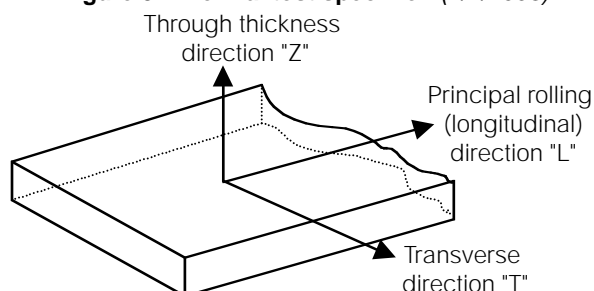

9.3 Manufacture

9.3.1 Approval (1/7/2003)

Z grade steel Manufacturers are to be approved by the Society for the specific "Z" quality.

The conditions for approval are indicated in the "Rules for the approval of Manufacturers of materials".

The procedure has to take into account the improved steel-making techniques of calcium treatment, vacuum degassing and argon stirring as well as the control of centre-line segregation during continuous casting.

9.4 Chemical composition

9.4.1 (1/7/2003)

In addition to the requirements of the appropriate steel specification, the maximum sulphur content is to be 0,008% determined by the ladle analysis.

9.5 Mechanical properties

9.5.1 The ductility in the direction of thickness is evaluated, for the purpose of these requirements with the value of the reduction area measured on tensile test specimens taken in the through thickness direction of the product and prepared as specified in [9.6.4].

9.6 Test Procedure

9.6.1 General (1/7/2003)

In addition to the requirements of the appropriate steel specification, preparation of specimens and testing procedures are to be as indicated in the following items [9.6.2] to [9.7.1].

9.6.2 Test sampling (1/7/2003)

For plates and wide flats, one test sample is to be taken close to the longitudinal centreline of one end of each rolled piece representing the batch and where applicable preferably at the end corresponding to the top of the ingots. See Tab 29 and Fig 10.

9.6.3 Number of tensile test specimens (1/7/2003)

The test sample must be large enough to accommodate the preparation of 6 specimens. 3 test specimens are to be pre-

pared while the rest of the sample remains for possible retest.

9.6.4 Tensile test specimen dimensions (1/7/2015)

Round test specimens including the type built-up by welding are to be prepared in accordance with ISO 6892-84, EN 10164-93 or another recognised standard.

Table 29 : Batch size dependent on product and sulphur content (1/7/2003)

Product	S > 0,005%	S ≤ 0,005%
Plates	Each piece (parent plate)	Maximum 50t of products of the same cast, thickness and heat treatment
Wide flats of nominal thickness ≤ 25mm	Maximum 10t of products of the same cast, thickness and heat treatment	Maximum 50t of products of the same cast, thickness and heat treatment
Wide flats of nominal thickness > 25mm	Maximum 20t of products of the same cast, thickness and heat treatment	Maximum 50t of products of the same cast, thickness and heat treatment

9.7 Tensile test results

9.7.1 (1/7/2003)

The test is considered invalid and a further replacement test is required if the fracture occurs in the weld or heat affected zone.

The minimum average value for the reduction of area of at least 3 tensile test specimens taken in the through thickness direction is to be that shown for the appropriate grade given in Tab 30. Only one individual value may be below the minimum average but not less than the minimum individual value shown for the appropriate grade (see Fig 11).

A value less than the minimum individual value is a cause for rejection.

9.8 Re-test procedure

9.8.1 (1/7/2003)

Fig 11 shows the three cases where a re-test situation is permitted. In these instances three more tensile tests are to be taken from the remaining test sample. The average of all 6 tensile tests is to be greater than the required minimum average with no greater than two results below the minimum average.

In the case of failure after re-test, either the batch represented by the piece is rejected or each piece within the batch is required to be tested.

Table 30 : Reduction of area acceptance values (1/7/2003)

Grade	Z25	Z35
Minimum average	25%	35%
Minimum individual	15%	25%

9.9 Ultrasonic testing

9.9.1 (1/1/2023)

Ultrasonic testing is required and is to be performed in accordance with either EN 10160:1999 Level S1/E1 or ASTM A 578:2017 Level C.

Ultrasonic testing should be carried out on each piece in the final supply condition and with a probe frequency of 4MHz.

9.10 Marking

9.10.1 (1/7/2003)

Products complying with these requirements are to be marked in accordance with the appropriate steel requirement and in addition with the notation Z25 or Z35 added to the material grade designation, e.g. EH36Z25 or EH36Z35.

9.11 Certification

9.11.1 (1/7/2003)

The following information is required to be included on the certificate in addition to the appropriate steel requirement:

- through thickness reduction in area (%)
- steel grade with Z25 or Z35 notation.

Figure 10 : Plate and wide flat sampling position (1/7/2003)

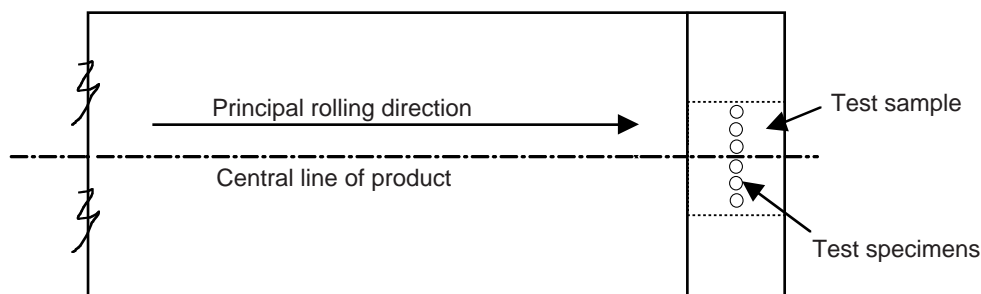
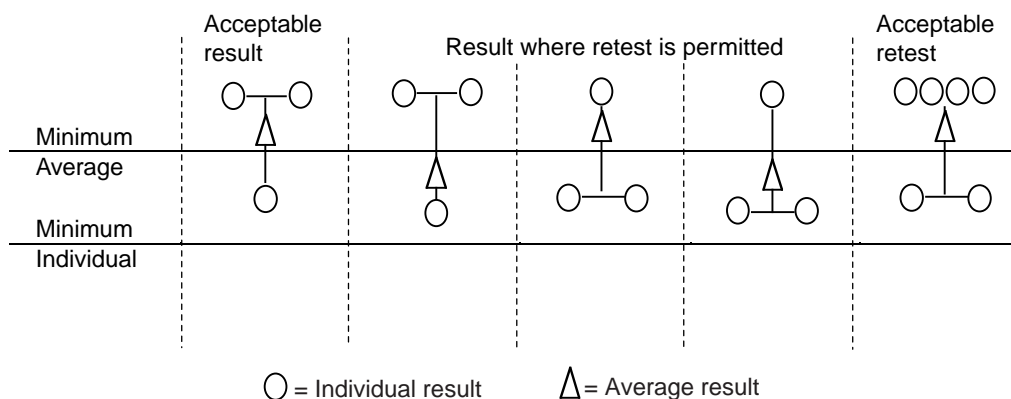

Figure 11 : Diagram showing acceptance / rejection and retest criteria (1/7/2003)



10 Extremely Thick Steel Plates in container ships

10.1 Application

10.1.1 (1/1/2017)

The requirements of this Article [10] apply to steel plates for container ships incorporating extremely thick steel plates having steel grade and thickness in accordance with [10.2] and [10.3].

10.1.2 (1/1/2017)

This Article identifies when measures for the prevention of brittle fracture of extremely thick steel plates are required for longitudinal structural members.

10.1.3 (1/1/2021)

This Article defines the following methods to apply to the extremely thick plates of container ships for preventing the crack initiation and propagation:

- a) Non-Destructive Testing (NDT) during construction detailed in [10.5]
- b) Periodic NDT after delivery detailed in [10.6]
- c) Brittle crack arrest design detailed in [10.7].

10.1.4 (1/1/2021)

This Article gives the basic concepts for application of extremely thick steel plates to longitudinal structural members in the upper deck.

10.1.5 (1/1/2021)

For the application of this Article, the upper deck region means the upper deck plating, hatch side coaming plating, hatch coaming top plating and their attached longitudinals.

10.1.6 (1/1/2014)

The application of the measures specified in [10.5], [10.6] and [10.7] is to be in accordance with App 1.

10.2 Steel grades

10.2.1 (1/1/2021)

This Article is to be applied when any of YP36, YP40 and YP47 steel plates are used for the longitudinal structural members in the upper deck region.

Note 1: YP36, YP40 and YP47 refers to the minimum specified yield strength of steel of 355, 390 and 460 N/mm², respectively.

10.2.2 (1/1/2021)

In case YP47 steel plates are used for longitudinal structural members in the upper deck region, the steel plates are to be of EH47 grade as specified in [10].

10.3 Thickness

10.3.1 (1/1/2014)

For steel plates with thickness of over 50mm and not greater than 100mm, the measures for prevention of brittle crack initiation and propagation specified in this [10.5], [10.6] and [10.7] are to be taken.

10.3.2 (1/1/2014)

For steel plates with thickness exceeding 100mm, appropriate measures for prevention of brittle crack initiation and propagation are to be agreed with the Society.

10.4 Hull structure (for purpose of design)

10.4.1 Material factor k (1/1/2021)

For the material factors of YP36 and YP40 refer to Part B.

The material factor of YP47 steel for the assessment of hull girder strength is to be taken as $k = 0.62$.

10.4.2 Fatigue assessment (1/1/2021)

The fatigue assessment of the longitudinal structural members is to be performed in accordance with the Society's procedures.

10.4.3 Details of construction design (1/1/2021)

Special consideration is to be paid to the construction details where extremely thick steel plates are applied to structural members such as connections between outfitting and hull structures. Connections details are to be in accordance with the Society's requirements.

10.5 Non-Destructive Testing during construction (Measure No 1 of Appendix 1)

10.5.1 General (1/7/2021)

- a) Where non-destructive testing (NDT) during construction is required in App 1, the NDT is to be in accordance with b) and [10.5.2]. Enhanced NDT as specified

in [10.7.3] e) is to be carried out in accordance with an appropriate standard.

- b) Ultrasonic testing (UT) in accordance with the RINA Rules for carrying out non-destructive examinations of welding is to be carried out on all block-to-block butt joints of all upper flange longitudinal structural members in the cargo hold region. Upper flange longitudinal structural members include the topmost strakes of the inner hull/bulkhead, the sheer strake, main deck, coaming plate, coaming top plate, and all attached longitudinal stiffeners. These members are defined in Fig 12.

Figure 12 : Upper flange longitudinal structural members (1/1/2014)

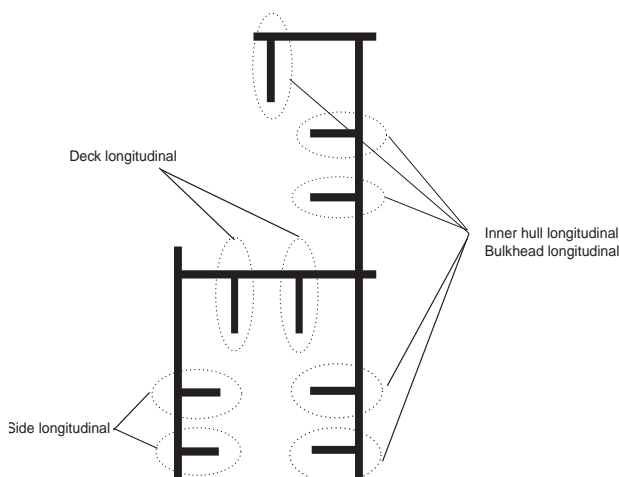

10.5.2 Acceptance criteria of UT (1/7/2021)

Acceptance criteria of UT are to be in accordance with the RINA Rules for carrying out non-destructive examinations of welding.

The acceptance criteria may be adjusted under consideration of the appertaining brittle crack initiation prevention procedure and where this is more severe than that found in the RINA Rules for carrying out non-destructive examinations of welding, the UT procedure is to be amended accordingly to a more severe sensitivity.

10.6 Periodic NDT after delivery (Measure No.2 of Appendix 1)

10.6.1 General (1/7/2021)

- Where periodic NDT after delivery is required, the NDT is to be in accordance with item b), [10.6.2] and [10.6.3].
- The procedure of the NDT is to be in accordance with the RINA Rules for carrying out non-destructive examinations of welding, irrespective of the applicability clause for new building in Chapter 1, [1.1.1] of the

RINA Rules for carrying out non-destructive examinations of welding.

10.6.2 Timing of UT (1/1/2014)

Where UT is carried out, the frequency of survey is to be agreed with the Society.

10.6.3 Acceptance criteria of UT (1/7/2021)

Where UT is carried out, acceptance criteria of UT are to be in accordance with the RINA Rules for carrying out non-destructive examinations of welding, irrespective of the applicability clause for new building in Chapter 1, [1.1.1] of the RINA Rules for carrying out non-destructive examinations of welding.

10.7 Brittle crack arrest design (Measures No.3, 4 and 5 of Appendix 1)

10.7.1 General (1/1/2021)

The brittle crack arrest steel method detailed in [10.7] may be used when the measures No. 3, 4 and 5 of App 1 are applied and the steel grade material of the upper deck is not higher than YP40. Otherwise other means for preventing the crack initiation and propagation is to be agreed with the Society.

Measures for the prevention of brittle crack propagation are to be taken within the cargo hold region. A brittle crack arrest design means a design using these measures.

The measures given in [10.7] generally apply to the block-to-block joints but it should be noted that cracks can initiate and propagate away from such joints. Therefore, appropriate measures should also be considered for the cases specified in [10.7.2] b) 2).

Brittle crack arrest steels are defined in [11.4.2].

10.7.2 Functional requirements of brittle crack arrest design (1/1/2021)

The purpose of the brittle crack arrest design is to arrest propagation of a crack at a proper position and to prevent large scale fracture of the hull girder.

- The locations of most concern for brittle crack initiation and propagation are the block-to-block butt weld joints either on hatch side coaming or on upper deck plating. Other locations in block fabrication where joints are aligned may also present higher opportunity for crack initiation and propagation along butt weld joints.
- Both of the following cases are to be considered:
 - where the brittle crack runs straight along the butt joint, and
 - where the brittle crack initiates in the butt joint but deviates away from the weld and into the plate, or where the brittle crack initiates from any other weld (see the figure below for definition of other welds) and propagates into the plate.

Note 1: "Other weld" includes the following (refer to Fig 13):

- 1) Fillet weld between hatch side coaming plating, including top plating, and longitudinals;
- 2) Fillet weld between hatch side coaming plating, including top plating and longitudinals, and attachments. (e.g., Fillet weld between hatch side top plating and hatch cover pad plating.);
- 3) Fillet weld between hatch side coaming top plating and hatch side coaming plating;
- 4) Fillet weld between hatch side coaming plating and upper deck plating;
- 5) Fillet weld between upper deck plating and inner hull/bulk-heads;
- 6) Fillet weld between upper deck plating and longitudinal; and
- 7) Fillet weld between sheer strakes and upper deck plating.

Figure 13 : Other Weld Areas (1/1/2017)

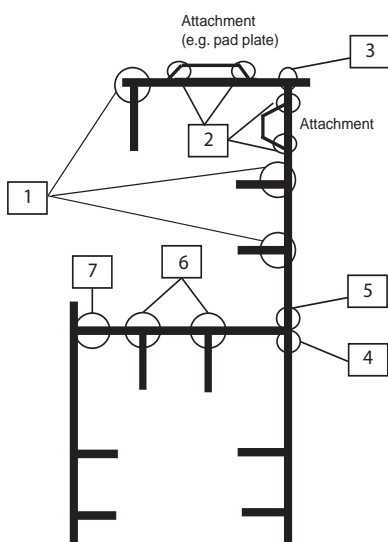

10.7.3 Concept examples of brittle crack arrest design (1/1/2021)

The followings are considered acceptable examples of measures that can be used on a brittle crack arrest-design to prevent brittle crack propagations. The detail design arrangements are to be submitted for approval to the Society. Other measures may be considered and accepted for review by the Society.

Brittle crack arrest design for [10.7.2] b) 2).

- a) Brittle crack arrest steel is to be used for the upper deck plating along the cargo hold region in a way suitable to

arrest a brittle crack initiating from the coaming and propagating into the structure below.

Brittle crack arrest design for [10.7.2] b) 1).

- b) Where the block to block butt welds of the hatch side coaming and those of the upper deck are shifted, this shift is to be greater than or equal to 300mm. Brittle crack arrest steel is to be provided for the hatch side coaming plating.
- c) Where crack arrest holes are provided in way of the block-to-block butt welds at the region where hatch side coaming weld meets the deck weld, the fatigue strength of the lower end of the butt weld is to be assessed. Additional countermeasures are to be taken for the possibility that a running brittle crack may deviate from the weld line into upper deck or hatch side coaming. These countermeasures are to include the application of brittle crack arrest steel in hatch side coaming plating.
- d) Where Arrest Insert Plates of brittle crack arrest steel or Weld Metal Inserts with high crack arrest toughness properties are provided in way of the block-to-block butt welds at the region where hatch side coaming weld meets the deck weld, additional countermeasures are to be taken for the possibility that a running brittle crack may deviate from the weld line into upper deck or hatch side coaming. These countermeasures are to include the application of brittle crack arrest steel in hatch side coamings plating.
- e) The application of enhanced NDT particularly time of flight diffraction (TOFD) technique using stricter defect acceptance in lieu of the standard UT technique specified in [10.5] can be an alternative to b), c) and d).

10.7.4 Selection of brittle crack arrest steels (1/1/2021)

- a) The brittle crack arrest steels fitted in the upper deck region of container ships are to comply with Tab 31 where suffixes BCA1 and BCA2 are defined in Tab 34.
- b) The brittle crack arrest steel property is to be selected for each individual structural member with thickness above 50 mm according to Tab 31.
- c) When brittle crack arrest steels as specified in Tab 31 are used, the weld joints between the hatch coaming side and the upper deck are to be partial penetration weld details approved by the Society.

In the vicinity of ship block joints, alternative weld details may be used for the deck and hatch coaming side connection provided additional means for preventing the crack propagation are implemented and agreed by the Society in this connection area.

Table 31 : Brittle crack arrest steel requirement in function of structural members and thickness (1/1/2021)

Structural Members plating (1)	Thickness (mm)	Brittle crack arrest steel requirement
Upper deck	$50 < t \leq 100$	Steel grade YP36 or 40 with suffix BCA1
Hatch coaming side	$50 < t \leq 80$	Steel grade YP 40 or 47 with suffix BCA1
	$80 < t \leq 100$	Steel grade YP 40 or 47 with suffix BCA2
(1) Excluding their attached longitudinals		

11 YP47 Steels and Brittle Crack Arrest Steels

11.1 Scope

11.1.1 General (1/1/2021)

This Article defines the requirements on YP47 steels and brittle crack arrest (BCA) steels as required in [10].

Unless otherwise specified in this Article, requirements in [2] are to be followed.

11.1.2 YP47 steels (1/1/2021)

Steels designated as YP47 refer to steels with a specified minimum yield point of 460 N/mm².

The YP47 steel can be applied to longitudinal structural members in the upper deck region of container carriers (such as hatch side coaming, hatch coaming top and the attached longitudinals). Special consideration is to be given to the application of YP47 steel plate for other hull structures.

This Article gives the requirements for YP47 steels in thickness greater than 50mm and not greater than 100mm intended for the upper deck region of container carriers. For

YP47 steels outside scope of the said thickness range, special consideration is to be given by the Society.

11.1.3 Brittle crack arrest steels (1/1/2021)

The brittle crack designation can be assigned to YP36 and YP40 steels specified in [2] and YP47 steels specified in this Article, which meet the additional brittle crack arrest requirements and properties defined in this Article.

The application of brittle crack arrest steels is to comply with [10], which covers longitudinal structural members in the upper deck region of container carriers (such as hatch side coaming, upper deck, hatch coaming top and the attached longitudinals, etc.).

The thickness range of brittle crack arrest steels is over 50mm and not greater than 100mm as specified in Tab 34.

11.2 Material specifications

11.2.1 YP47 steels (1/1/2021)

Material specifications for YP47 steels are specified in Tab 32 and Tab 33.

Table 32 : Chemical composition and deoxidation practice for YP47 steels without specified brittle crack arrest properties (1/1/2021)

Grade	EH47
Deoxidation Practice	Killed and fine grain treated
Chemical Composition % (ladle samples) ⁽⁶⁾⁽⁷⁾	
C max.	0,18
Mn	0,90 - 2,00
Si max.	0,55
P max	0,020
S max.	0,020
Al (acid soluble min)	0,015 ⁽¹⁾⁽²⁾
Nb	0,02 - 0,05 ⁽²⁾⁽³⁾
V	0,05 - 0,10 ⁽²⁾⁽³⁾

Grade	EH47
Ti max.	0,02 ⁽³⁾
Cu max.	0,35
Cr max.	0,25
Ni max.	1,0
Mo max.	0,08
C _{eq} max. ⁽⁴⁾	0,49
P _{cm} max. ⁽⁵⁾	0,22

Notes:

(1) The total aluminium content may be determined instead of the acid soluble content. In such cases the total aluminium content is to be not less than 0.020%.

(2) The steel is to contain aluminium, niobium, vanadium or other suitable grain refining elements, either singly or in any combination. When used singly the steel is to contain the specified minimum content of the grain refining element. When used in combination, the specified minimum content of a fine graining element is not applicable

(3) The total niobium, vanadium and titanium content is not to exceed 0.12%

(4) The carbon equivalent C_{eq} value is to be calculated from the ladle analysis using the following formula:

$$C_{eq} = C + \frac{Mn}{6} + \frac{Cr + Mo + V}{5} + \frac{Ni + Cu}{15} \text{ (%)}$$

(5) Cold cracking susceptibility P_{cm} value is to be calculated using the following formula:

$$P_{cm} = C + \frac{Si}{30} + \frac{Mn}{20} + \frac{Cu}{20} + \frac{Ni}{60} + \frac{Cr}{20} + \frac{Mo}{15} + \frac{V}{10} + 5B \text{ (%)}$$

(6) Where additions of any other element have been made as part of the steelmaking practice subject to approval by the Society, the content is to be indicated on product inspection certificate

(7) Variations in the specified chemical composition may be allowed subject to approval of the Society

Table 33 : Conditions of supply, grade and mechanical properties for YP47 steels without specified brittle crack arrest properties ⁽¹⁾ (1/1/2021)

Supply condition	Grade	Tensile test			Impact test			
		Yield Strength (N/mm ²) min.	Tensile Strength (N/mm ²)	Elongation (%) min	Test Temp. (°C)	Average Impact Energy(J) min.		
						50 < t ≤ 70 Longitudinal	70 < t ≤ 85 Longitudinal	85 < t ≤ 100 Longitudinal
TMPC (2)	EH47	460	570 - 720	17	-40°C	53	64	75

Note 1:
t : thickness (mm)

(1) The additional requirements for YP47 steel with brittle crack arrest properties is specified in [11.2.2].

(2) Other conditions of supply will be considered by the Society on a case by case basis.

11.2.2 Brittle crack arrest steels (1/1/2021)

Brittle crack arrest steels are defined as steel plate with the specified brittle crack arrest properties measured by either the brittle crack arrest toughness K_{ca} or Crack Arrest Temperature (CAT).

In addition to the required mechanical properties in [2] for YP36 and YP40 and Tab 33 for YP47, brittle crack arrest

steels are to comply with the requirements specified in Tab 34 and Tab 35.

The brittle crack arrest properties specified in Tab 34 are to be evaluated for the products in accordance with the procedure approved by the Society. Test specimens are to be taken from each piece (means "the rolled product from a single slab or ingot if this is rolled directly into plates" as defined in [2]), unless otherwise agreed by the Society.

Table 34 : Requirement of brittle crack arrest properties for brittle crack arrest steels (1/1/2021)

Suffix to the steel grade (1)	Thickness range (mm)	Brittle crack arrest properties (2) (6)	
		Brittle Crack Arrest Toughness K_{ca} at -10 °C (N/mm ^{3/2}) (2) (3)	Crack Arrest Temperature CAT (°C) (4)
BCA1	50 < t ≤ 100	6,000 min.	-10 or below
BCA2	80 < t ≤ 100 (7)	8,000 min.	(5)

Note 1:
t : thickness (mm)

(1) Suffix "BCA1" or "BCA2" is to be affixed to the steel grade designation (e.g. EH40-BCA1, EH47-BCA1, EH47-BCA2, etc.).

(2) Brittle crack arrest properties for brittle crack arrest steels are to be verified by either the brittle crack arrest toughness K_{ca} or Crack Arrest Temperature (CAT).

(3) K_{ca} value is to be obtained by the brittle crack arrest test specified in App 4 .

(4) CAT is to be obtained by the test method specified in App 5.

(5) Criterion of CAT for brittle crack arrest steels corresponding to $K_{ca}=8,000$ N/mm^{3/2} is to be approved by the Society.

(6) Where small-scale alternative tests are used for product testing (batch release testing), these test methods are to be approved by the Society.

(7) Lower thicknesses may be approved at the discretion of the Society.

Table 35 : Chemical composition and deoxidation practice for brittle crack arrest steels (1/1/2021)

Grade	EH36-BCA	EH40-BCA	EH47-BCA
Deoxidation Practice	Killed and fine grain treated		
Chemical Composition % (ladle samples) (1) (7) (8)			
C max.	0,18		0,18
Mn	0,90 - 2,00		0,90 - 2,00
Si max.	0,50		0,55
P max	0,020		0,020
S max.	0,020		0,020
Al (acid soluble min)	0,015 (2) (3)		0,015 (2) (3)
Nb	0,02 - 0,05 (3) (4)		0,02 - 0,05 (3) (4)
V	0,05 - 0,10 (3) (4)		0,05 - 0,10 (3) (4)
Ti max.	0,02 (4)		0,02 (4)
Cu max.	0,50		0,50
Cr max.	0,25		0,50
Ni max.	2,0		2,0
Mo max.	0,08		0,08
C_{eq} max. (5)	0,47 0,49 for EH40-BCA		0,55

Grade	EH36-BCA	EH40-BCA	EH47-BCA
P _{cm} max. (6)	-		0,24

Notes:

- (1) Chemical composition of brittle crack arrest steels shall comply with Tab 35, regardless of chemical composition specified in [2] and Tab 32.
- (2) The total aluminium content may be determined instead of the acid soluble content. In such cases the total aluminium content is to be not less than 0,020%.
- (3) The steel is to contain aluminium, niobium, vanadium or other suitable grain refining elements, either singly or in any combination. When used singly the steel is to contain the specified minimum content of the grain refining element. When used in combination, the specified minimum content of a fine graining element is not applicable.
- (4) The total niobium, vanadium and titanium content is not to exceed 0,12%.
- (5) The carbon equivalent C_{eq} value is to be calculated from the ladle analysis using the following formula:
$$C_{eq} = C + \frac{Mn}{6} + \frac{Cr + Mo + V}{5} + \frac{Ni + Cu}{15} \text{ (%)}$$
- (6) Cold cracking susceptibility P_{cm} value is to be calculated using the following formula:
$$P_{cm} = C + \frac{Si}{30} + \frac{Mn}{20} + \frac{Cu}{20} + \frac{Ni}{60} + \frac{Cr}{20} + \frac{Mo}{15} + \frac{V}{10} + 5B \text{ (%)}$$
- (7) Where additions of any other element have been made as part of the steelmaking practice subject to approval by the Society, the content is to be indicated on product inspection certificate.
- (8) Variations in the specified chemical composition may be allowed subject to approval of the Society

11.3 Manufacturing approval

11.3.1 (1/1/2021)

Provisions for the approval of YP47 steels and brittle crack arrest steels are given in the "Rules for the approval of Manufacturers of materials".

11.4 Welding of YP47 steels

11.4.1 Welding procedure qualification (1/1/2021)

Approval test items, test methods and acceptance criteria are to be in accordance with Ch 5, Sec 4 except for the provisions of this Article.

Approval range is to be in accordance with Ch 5, Sec 4, [2.7].

Impact test to be carried out according to Ch 5, Sec 4, [2.1.8]. Minimum average absorbed energy of 64J at -20°C is to be satisfied.

Hardness test to be carried out according to Ch 5, Sec 4, [2.1.10]. Measurement points are to include mid-thickness position in addition to those required in Ch 5, Sec 4, [2.1.10]. The results of hardness tests are not to exceed 350 HV.

Tensile strength in transverse tensile test is to be not less than 570 N/mm².

Deep notch test or CTOD test may be required.

11.4.2 Welders (1/1/2021)

Welders engaged in YP47 welding work are to possess welder's qualifications specified in Ch 5, Sec 6.

11.4.3 Welding consumables (1/1/2021)

Approval procedure, approval test items, test methods and acceptance criteria not specified in this Article are to be in accordance with Ch 5, Sec 2.

Specifications of welding consumables for YP47 steel plates are to be in accordance with Tab 36.

Table 36 : Mechanical properties for deposited metal tests for welding consumables (1/1/2021)

Mechanical Properties			Impact test	
Yield Strength (N/mm ²) min.	Tensile Strength (N/mm ²)	Elongation (%) min	Test Temp. (°C)	Average Impact Energy(J) min.
460	570 - 720	19	-20°C	64

Consumable tests for butt weld assemblies are to be in accordance with Tab 37.

Table 37 : Mechanical properties for butt weld tests for welding consumables (1/1/2021)

Tensile Strength (N/mm ²)	Bend test ratio: D/t	Charpy V-notch impact tests	
		Test Temp. (°C)	Average absorbed energy (J) min.
570 - 720	4	-20°C	64

11.4.4 Production welding (1/1/2021)

Short bead length for tack and repairs of welds by welding are not to be less than 50mm.

In the case where P_{cm} is less than or equal to 0,19, 25mm of short bead length may be adopted with approval of the Society.

Preheating is to be 50°C or over when air temperature is 5°C or below.

In the case where P_{cm} is less than or equal to 0,19 and the air temperature is below 5°C but above 0°C, alternative pre-heating requirements may be adopted with approval of the Society.

Special care is to be paid to the final welding so that harmful defects do not remain.

Jig mountings are to be completely removed with no defects in general, otherwise the treatment of the mounting is to be accepted by the Society.

11.5 Welding of brittle crack arrest steels**11.5.1 Welding procedure qualification (1/1/2021)**

Where Welding Procedure Specification (WPS) for the non-BCA steels has been approved by the Society, the said WPS is applicable to the same welding procedure applied to the same grade with suffix "BCA1" or "BCA2" specified in Tab 34 except high heat input processes over 50kJ/cm.

The requirements for welding procedure qualification test for brittle crack arrest steels is to be in accordance with the relevant requirements for each steel grade excluding suffix "BCA1" or "BCA2" specified in Tab 34, with the following exception for hardness test. For YP47 steels with brittle crack arrest properties, HV10, as defined in Ch 5, Sec 4, [2.1.10], is to be not more than 380. Measurement points are to include mid-thickness position in addition to the points required in Ch 5, Sec 4, [2.1.10].

11.5.2 Welding work (1/1/2021)

Welding work (such as relevant welder's qualification, short bead, preheating, selection of welding consumable, etc.) for brittle crack arrest steels is to be in accordance with the relevant requirements for each steel grade excluding suffix "BCA1" or "BCA2" specified in Tab 34.

12 Normal and higher strength corrosion resistant steels for cargo oil tanks**12.1 Scope****12.1.1 (1/1/2014)**

The requirements of this Article [12] apply to normal and higher strength corrosion resistant steels when such steel is used as the alternative means of corrosion protection for cargo oil tanks as specified in the IMO performance standard MSC.289 (87) of Regulation 3-11, Part A-1, Chapter II-1 of the SOLAS Convention (Corrosion protection of cargo oil tanks of crude oil tankers).

12.1.2 (1/1/2014)

The requirements are primarily intended to apply to steel products with a thickness as follows:

For steel plates and wide flats:

- All Grades: up to 50 mm in thickness

For sections and bars

- All Grades: up to 50 mm in thickness.

12.1.3 (1/1/2014)

Normal and higher strength corrosion resistant steels as defined in this Article, are steels whose corrosion resistance performance in the bottom or top of the internal cargo oil tank is tested and approved to satisfy the requirements in IMO MSC.289 (87) in addition to other relevant requirements for ship material, structural strength and construction. It is not intended that such steels be used for corrosion resistant applications in other areas of a vessel that are outside of those specified in the IMO performance standard MSC.289 (87) of Regulation 3-11, Part A-1, Chapter II-1 of the SOLAS Convention.

12.1.4 (1/1/2014)

Since corrosion resistant steels are similar to the ship steels as specified in this Sec 1, the basic requirements of this Section apply to these steels except where modified by this Article [12].

12.1.5 (1/1/2014)

The weldability of corrosion resistant steels is similar to that given in this Sec 1, therefore welding requirements specified in Ch 5, Sec 2 and Ch 5, Sec 4 also apply except as modified by this Article [12].

12.2 Approval**12.2.1 (1/1/2014)**

All materials are to be manufactured at works which have been approved by the Society.

12.2.2 (1/1/2014)

Corrosion tests are to be carried out in accordance with App 3. Approval can be given for application in one of the following areas of a cargo oil tank:

- a) Lower surface of strength deck and surrounding structures;
- b) Upper surface of inner bottom plating and surrounding structures;
- c) For both strength deck and inner bottom plating.

12.2.3 (1/1/2014)

It is the manufacturer's responsibility to ensure that effective process and production controls in operation are adhered to within the manufacturing specifications. If the process or production controls are changed in any way, or any product fails to meet specifications, the manufacturer is to issue a report explaining the reasons, and, in the instance of product which fails to meet specifications, the measures to prevent recurrence. The complete report is to be submitted to the Surveyor along with such additional information as the Surveyor may require. Each affected piece is to be tested to the Surveyor's satisfaction. The frequency of testing for subsequent products is at the discretion of the Society.

12.3 Method of manufacture

12.3.1 (1/1/2014)

Method of manufacture, deoxidation practice and rolling practice is to be in accordance with the requirements of this Section.

12.4 Chemical composition

12.4.1 (1/1/2014)

The chemical composition of samples taken from each ladle of each cast is to be determined by the manufacturer in an adequately equipped and competently staffed laboratory and is to be in accordance with the appropriate requirements of this Sec 1.

12.4.2 (1/1/2014)

The manufacturer will establish a relationship of all the chemical elements which affect the corrosion resistance, the chemical elements added or controlled to achieve this are to be specifically verified for acceptance. Verification is to be based on the ladle analysis of the steel.

12.4.3 (1/1/2014)

The manufacturer's declared analysis will be accepted subject to periodic random checks as required by the Surveyor.

12.4.4 (1/1/2014)

The carbon equivalent is to be in accordance with the requirements of this Sec 1.

12.5 Condition of supply

12.5.1 (1/1/2014)

All materials are to be supplied in one of the supply conditions specified in this Sec 1.

12.6 Mechanical properties

12.6.1 (1/1/2014)

Tensile testing and Charpy V-notch Impact Testing is to be carried out in accordance with the provisions of this Sec 1.

12.7 Freedom from defects

12.7.1 (1/1/2014)

The steel is to be reasonably free from segregations and non-metallic inclusions. The finished material is to have a workmanlike finish and is to be free from internal and surface defects prejudicial to the use of the material for the intended application.

12.7.2 (1/1/2014)

The acceptance criteria for surface finish and procedures for the repair of defects, as detailed in IACS Recommendation No 12, "Guidance for the Surface Finish of Hot Rolled Steel Plates and Wide Flats" are to be observed.

12.8 Tolerances

12.8.1 (1/1/2014)

Unless otherwise agreed or specially required, the thickness tolerances according to the requirements of this Sec 1 are applicable.

12.9 Identification of materials

12.9.1 (1/1/2014)

The steelmaker is to adopt a system for the identification of ingots, slabs and finished pieces which will enable the material to be traced to its original cast.

12.9.2 (1/1/2014)

The Surveyor is to be given full facilities for so tracing the material when required.

12.10 Testing and inspection

12.10.1 Facilities for inspection (1/1/2014)

The manufacturer is to afford the Surveyor all necessary facilities and access to all relevant parts of the works to enable him to verify that the approved process is adhered to, for the selection of test materials, and the witnessing of tests, as required by the Rules, and for verifying the accuracy of the testing equipment.

12.10.2 Testing procedures (1/1/2014)

The prescribed tests and inspections are to be carried out at the place of manufacture before dispatch. The test specimens and procedures are to be in accordance with Ch 1, Sec 2. All the test specimens are to be selected and stamped by the Surveyor and tested in his presence, unless otherwise agreed.

12.10.3 Through thickness tensile tests (1/1/2014)

If plates and wide flats with thickness of 15 mm and over are ordered with through thickness properties, the through thickness tensile test in accordance with [9] is to be carried out.

12.10.4 Ultrasonic inspection (1/1/2014)

If plates and wide flats are ordered with ultrasonic inspection, this is to be made in accordance with an accepted standard at the discretion of the Society.

12.10.5 Surface inspection and dimensions (1/1/2014)

Surface inspection and verification of dimensions are the responsibility of the steel maker. The acceptance by the Society's Surveyor shall not absolve the steel maker from this responsibility.

12.11 Test material**12.11.1 (1/1/2014)**

Definitions and requirements for test samples are to be in accordance with this Sec 1.

12.12 Test specimens**12.12.1 Mechanical test specimens (1/1/2014)**

The dimensions, orientation and location of the tensile and Charpy V-notch test specimens within the test samples are to be in accordance with Ch 1, Sec 2 and this Section.

12.13 Number of test specimens**12.13.1 (1/1/2014)**

The number of Tensile and Charpy V-notch Impact test specimens are to be in accordance with this Sec 1.

12.14 Branding**12.14.1 (1/1/2014)**

Every finished piece is to be clearly marked by the maker in at least one place with the Society's brand and the following particulars:

- a) Unified identification mark for the grade of steel (e.g. [A36]).
- b) Steel plates that have complied with these requirements will be marked with a designation by adding a corrosion designation to the unified identification mark for the grade of steel. Example of designation: A36 RCB
- c) The corrosion resistant steel is to be designated according to its area of application as follows:
 - Lower surface of strength deck and surrounding structures; RCU
 - Upper surface of inner bottom plating and surrounding structures; RCB
 - For both strength deck and inner bottom plating; RCW
- d) When required by the Society, material supplied in the thermo mechanically controlled process condition is to have the letters TM added after the identification mark but before the corrosion designation. (e.g. [E36] TM RCU Z35).
- e) Name or initials to identify the steelworks.
- f) Cast or other number to identify the piece.
- g) If required by the purchaser, his order number or other identification marks.

12.14.2 (1/1/2014)

The above particulars, but excluding the manufacturer's name or trade marks where this is embossed on finished products are to be encircled with paint or otherwise marked so as to be clearly legible.

12.14.3 (1/1/2014)

Where a number of light materials are securely fastened together in bundles the manufacturer may, subject to the agreement of the Society, brand only the top piece of each bundle, or alternatively, a firmly fastened durable label containing the brand may be attached to each bundle.

12.14.4 (1/1/2014)

In the event that any material bearing the Society's brand fails to comply with the test requirements, the brand is to be unmistakably defaced by the manufacturer.

12.15 Documentation**12.15.1 (1/1/2014)**

The Surveyor is to verify certificates before the material is accepted by the Society.

12.15.2 (1/1/2014)

The number of copies required is to be specified by the Society.

12.15.3 (1/1/2014)

The certificate is to be supplied in either electronic or paper format as required by the Society.

12.15.4 (1/1/2014)

The Society may require separate documents for each grade of steel.

12.15.5 (1/1/2014)

The certificate is to contain, in addition to the description, dimensions, etc., of the material, at least the following particulars:

- a) Purchaser's order number and if known the hull number for which the material is intended.
- b) Identification of the cast and piece including, where appropriate, the test specimen number.
- c) Identification of the steelworks.
- d) Identification of the grade of steel and the manufacturer's brand name.
- e) Ladle analysis.
- f) If the steel is approved in accordance with [12.2], the weight percentage of each element added or intentionally controlled to improve corrosion resistance.
- g) Condition of supply when other than as rolled i.e. normalised, controlled rolled or thermo mechanically rolled.
- h) Test results.

12.15.6 (1/1/2014)

Before the test certificates are signed by the Surveyor, the manufacturer is required to furnish him with a written declaration stating that the material has been made by an approved process and that it has been subjected to and has withstood satisfactorily the required tests in the presence of the Surveyor or his authorized deputy. The name of the Society is to appear on the test certificate. The following form of declaration will be accepted if stamped or printed

on each test certificate or shipping statement with the name of the steelworks and initialled for the makers by an authorized official:

"We hereby certify that the material has been made by an approved process and has been satisfactorily tested in accordance with the RINA Rules."

12.15.7 (1/1/2014)

In the case of electronic certification, the Society is to agree upon a procedure with the steel mill to ensure release is authorised by the Surveyor.

SECTION 2

STEEL PIPES, TUBES AND FITTINGS

1 General

1.1 Application

1.1.1 General (1/7/2022)

The requirements of this Section apply to seamless and welded steel pipes, tubes and fittings intended for boilers, pressure vessels and systems operating at ambient, high or low temperature.

Provision is also made for pipes intended for structural applications, at ambient temperature.

Article [1] specifies the requirements common to all the above-mentioned steel pipes, while the appropriate specific requirements are indicated in Articles [2] to [7].

Pipes assigned to Class 3 as defined in Pt C, Ch 1, Sec 10, [1.5] may be manufactured and tested in accordance with recognised national or international standards and, when fabricated by recognised Manufacturers, accepted on the basis of Manufacturer's test certificate (works' certificate W) without testing by the Society.

The general term pipes will be used in the following text to mean pipes and tubes.

In the case of applications involving the storage and transport of liquefied gases in bulk and the use of gases or other low-flashpoint fuels, the additional requirements in App 6 apply.

1.1.2 Special requirements

Special requirements may be specified in cases of applications intended for dangerous substances or particularly severe service conditions.

In cases of applications involving the storage and transport of liquefied gases, the requirements of Pt E, Ch 9, Sec 6 also apply, as appropriate.

1.1.3 Weldability

Steels in accordance with these rule requirements are weldable subject to the use of suitable welding processes and, where appropriate, to any conditions stated at the time of approval.

1.2 Manufacture

1.2.1 Manufacturing process

The steel used is to be manufactured as detailed in Sec 1, [1.2.1].

Unless a specific method is agreed for individual supplies, or specific requirements are given in the relevant Articles,

the pipes may be manufactured by one of the following methods:

- a) seamless, hot or cold finished
- b) welded, by automatic processes
- c) welded, as above hot and/or cold finished.

In the case of welded pipes, the following processes are to be used depending on the grade of steel:

- a) electrical resistance (ERW), induction (IW), submerged arc (SAW) welding for carbon and carbon manganese steels
- b) electric tungsten arc process (GTAW), plasma (PAW), submerged (SAW) arc welding for austenitic or austenitic-ferritic steels.

The welding process is to be approved according to the applicable requirements of Ch 5, Sec 2 of the Rules.

Nickel steel pipes are to be manufactured seamless.

Unless otherwise specified, the manufacturing process is left to the discretion of the Manufacturer.

1.3 Approval

1.3.1 Welded pipes and fittings and, unless otherwise specified by the Society, seamless pipes and fittings in low alloyed or alloyed steels, intended for high temperature are to be manufactured by approved Manufacturers.

In other cases the Manufacturers are in any event to be recognised by the Society.

The approval procedure is indicated in the "Rules for the approval of Manufacturers of materials".

1.4 Quality of materials

1.4.1 All pipes are to have a workmanlike finish consistent with the method of manufacture and to be free from defects and surface or internal imperfections which may impair their use in subsequent fabrication or service.

1.4.2 All pipes are to be reasonably straight and their ends are to be cut perpendicular to the axis without leaving chips or burrs.

1.5 Visual, dimensional and non-destructive examinations

1.5.1 Each pipe is to be submitted by the Manufacturer to visual examination and verification of dimensions.

All pipes intended for severe conditions, such as super heater tubes, pressure cylinders, pressure systems with working pressure higher than 4,0 N/mm², pipes conveying liquefied gases and dangerous media, are to be presented to the Surveyor for visual examination and verification of dimensions.

1.5.2 The dimensional tolerances on the thickness and diameter are to be in accordance with recognised standards.

In welded pipes, the weld reinforcement is to be well faired and within allowable limits.

1.5.3 Welded pipes are to be submitted by the Manufacturer to an appropriate, automatic non-destructive test of welded joints as specified at the approval.

1.6 Rectification of surface defects

1.6.1 Rectification of surface defects by grinding

Small surface defects and imperfections may be removed by grinding, provided that the pipe thickness after repair is within the permissible tolerance and the ground zone is well faired into the adjacent zone.

1.6.2 Rectification of surface defects by welding

Repairs by welding may be accepted at the Surveyor's discretion. The repair procedure is to be submitted for consideration.

The repaired areas are subsequently to be examined by magnetic particle or liquid penetrant methods and/or by other appropriate non-destructive tests.

1.7 Condition of supply

1.7.1 Pipes are to be supplied in the required heat treated or equivalent condition.

Where alternative supply conditions are accepted, the choice of the supply condition, unless otherwise required, is left to the Manufacturer; the condition of supply is always to be mentioned in the testing documentation.

1.7.2 Pipes which are to be expanded after supply are to be annealed at least at their ends.

1.8 Hydrostatic test

1.8.1 With the exception of pipes intended for structural application, each pipe is to be subjected to hydrostatic test at the Manufacturer's works.

The test pressure P , in N/mm^2 , is given by the following formula but the maximum pressure may not be higher than $14 N/mm^2$:

$$P = \frac{2tf}{D}$$

where :

- D : Nominal outside diameter of the pipe, in mm
- t : Nominal wall thickness of the pipe, in mm
- f : equal to:
 - 0,80 R_{eH} for ferritic steels
 - 0,70 $R_{p0,2}$ for austenitic or austenitic-ferritic steels.

The test pressure is to be maintained for a sufficient time to verify the tightness and at least for 5 seconds.

The test pressure is to be measured by means of a suitable, calibrated pressure gauge.

1.8.2 Unless otherwise agreed, the Manufacturer's certificate of the hydrostatic test is accepted.

The hydrostatic test of pipes intended for boilers, super heaters or pressure systems with working pressure higher than $4,0 N/mm^2$, or conveying liquefied gases and dangerous media, may be required to be witnessed by the Surveyor.

1.8.3 Subject to the prior approval of the procedure, a non-destructive test by ultrasonic or eddy current may be accepted as an alternative to the hydrostatic test.

1.9 Sampling and testing

1.9.1 Batch composition

Pipes are to be presented for mechanical and technological tests in the final supply condition and, unless otherwise indicated in the relevant Articles, in batches.

For pipes which are not heat treated, the batch is to consist of pipes of the same size, manufactured by the same procedure, from the same type of steel.

For pipes which are supplied in the heat treated condition, the batches are to consist of pipes of the same size, manufactured from the same type of steel and subjected to the same heat treatment in a continuous furnace or heat treated in the same furnace charge.

For pipes welded by the electric submerged arc welding process, the batch is also to consist of pipes welded with the same welding materials.

For pipes intended for low temperature service, the batch is also to consist of material originating from the same cast.

The size of the batch is to be in accordance with Tab 1.

Table 1 : Number of pipe as made lengths per batch

Outside diameter range (mm)	Maximum number of tubes per batch (1)
$D \leq 114,3$	200
$114,3 < D \leq 323,9$	100
$323,9 < D$	50
(1) Residual quantities of up to 10 lengths may be allocated to the other batches presented for testing.	

1.9.2 Sampling

The test samples are to be cut from a length selected at random from each batch, for the tests specified in the various Articles.

The specimens for all or part of the following tests, as detailed in the various Articles, are to be obtained from the individual samples.

- a) mechanical tests
 - tensile test, longitudinal direction
 - tensile test transverse to the weld for pipes with $D \geq 300$ mm
 - 3 Charpy V-notch impact tests, longitudinal direction.

For subsize specimens, reference is to be made to Ch 1, Sec 2, [4.2.2]. For pipes having thickness less

than 6 mm, reduced specimens having the maximum thickness are to be used.

b) technological tests

- flattening test

For welded pipes, two tests are to be carried out; in one test the specimen is to be positioned with the welded joint at 0°, in the other at 90°, to the direction of the force.

The distance between plates to be reached during the test is determined by the following formula:

$$z = \frac{(1+C)t}{C + \frac{t}{D}}$$

where the value of C is indicated in the tables relevant to the mechanical properties of the various pipes

- a bend test is to be performed in lieu of the flattening test for pipes having $D > 400\text{mm}$ or thickness greater than 15% of D.

For welded pipes, one test is carried out with the outside surface of the pipe in tension and the other with the inside surface of the pipe in tension. The mandrel diameter is indicated in the various Articles and the bend angle is to be equal to 180°.

- flanging or drift expanding test for pipes having $D \leq 150\text{ mm}$ or thickness $\leq 9\text{ mm}$.

1.9.3 Preparation of test specimens

For the preparation of test specimens and for the testing procedures, reference is to be made to the applicable requirements of Ch 1, Sec 2.

1.9.4 Tensile and technological tests

The results of the test are to comply with the values specified in the appropriate tables.

If during the tensile test there is no marked yield stress R_{eH} , the 0,2% proof stress $R_{p0,2}$ is taken as an alternative.

1.9.5 Impact test

The average value is to comply with the minimum average value required; only one individual value may be less than the average value required, provided that it is not less than 70% of it. The values required for the various products are relevant to standard specimens $10 \times 10\text{ mm}^2$.

For subsize specimens reference is to be made to Ch 1, Sec 2, [4.2.2].

For reduced specimens obtained from pipes having thickness less than 6 mm, the energy required is proportional to the area of the specimen, referring to the specimen $10 \times 5\text{ mm}^2$ and to the energy required for this specimen.

1.9.6 Re-test procedure

For re-test procedures reference is to be made to Ch 1, Sec 1, [3.5].

1.10 Identification and marking

1.10.1 The Manufacturer is to adopt a system of identification which enables the material to be traced to its original cast, as appropriate.

1.10.2 All pipes and tubes are to be identified and marked with the following indications:

- Society's brand
- Manufacturer's name or trade mark
- identification mark for the type of steel
- cast number or identification number and/or letters, which will enable the history of the fabrication of the piece or bundle to be traced.

Marking is to be applied by punching. In the case of small wall thickness which may be damaged by punching, alternative methods such as paint, electrical engraving or rubber stamps may be used.

Marking on labels is accepted for small pipes, see Ch 1, Sec 1, [4.1.2].

1.11 Documentation and certification

1.11.1 The testing documentation indicated in Ch 1, Sec 1, [4.2.1] is to be issued and is to include all the required information, as appropriate.

The ladle analysis is to include the content of refining and alloying elements as applicable.

If rimming steel is supplied, this condition is to be stated on the certificate.

1.11.2 When pipes are made from steel produced in a mill other than that where the pipes are manufactured, the Surveyor is to be supplied with a steelmaker's certificate stating the manufacturing process, the grade of steel, the cast number and the relevant ladle analysis.

2 Pipes for pressure systems operating at ambient temperature

2.1 Application

2.1.1 The requirements of this Article apply to seamless and welded carbon and carbon manganese steel pipes, intended for piping systems or pressure vessels operating at ambient temperature or when impact properties at a temperature not lower than -20°C are specified.

2.2 Steel grades

2.2.1 The requirements apply to carbon and carbon manganese steels, which are classed into five groups indicated by the minimum ultimate tensile strength R_m , in N/mm^2 : 320, 360, 410, 460 and 510.

Each group is further subdivided into grades HA, HB and HD, based on quality level and impact properties, as applicable.

The letters HA, HB and HD mean impact properties at $+20^\circ\text{C}$, 0°C and -20°C , respectively.

2.3 Condition of supply

2.3.1 Seamless cold finished pipes are to be normalised, while hot finished pipes may be normalised or normalised formed.

Welded pipes are to be supplied in the condition specified at the approval.

At the Manufacturer's discretion, normalising and tempering may be carried out in lieu of normalising; see [1.7].

2.4 Chemical composition

2.4.1 The method of deoxidation and chemical composition on ladle analysis are to comply with the requirements specified in Tab 2.

2.5 Mechanical properties

2.5.1 The mechanical properties are specified in Tab 3.

2.6 Mechanical and technological tests

2.6.1 For pipes intended for pressure cylinders, the tests are to be carried out on each as made length.

Pipes intended for other applications are to be presented in batches, as specified in Tab 1.

One pipe is to be selected from each batch for the required tests as follows:

a) seamless pipes:

- one tensile test, longitudinal direction
- one flattening test or one bend test
- 3 Charpy V-notch impact tests, longitudinal direction, for pipes having thickness ≥ 11 mm and, when impact properties are required at -20°C , for thickness ≥ 6 mm

b) welded pipes:

- one tensile test on base metal, longitudinal direction
- one tensile test transverse to the weld for pipes with $D \geq 300$ mm
- two flattening tests or two bend tests
- 3 Charpy V-notch impact tests, longitudinal direction, for pipes having thickness ≥ 11 mm and, when impact properties are required at -20°C , for thickness ≥ 6 mm.

3 Pipes for structural applications

3.1 Application

3.1.1 Steel pipes for structural application at ambient temperature are to comply with the requirements specified in Article [2], with the exception of the hydrostatic test which is not required.

3.2 Steel grades

3.2.1 Unless otherwise agreed with the Society, steel grades are to correspond to the types specified in Article [2] with designation 410 HB-HD 460 HB-HD and 510 HB-HD.

The symbol ST is to be added to the steel designation to clearly indicate that pipes are intended for structural application.

4 Pipes for high temperature service

4.1 Application

4.1.1 The requirements of this Article apply to seamless and welded pipes intended for boilers, superheaters and heat exchangers, or pressure parts operating at elevated temperatures.

Table 2 : Chemical composition

Steel grade	Deoxidation	Chemical composition (%) (1)					
		C max	Mn	Si max	P max	S max	Al tot. min. (1)
320 HA	semi-killed or killed (2)	0,16	0,40 - 0,70	0,35	0,040	0,040	
360 HA 360 HB	semi-killed or killed	0,17	0,40 - 1,00	0,35	0,040	0,040	
410 HB	killed	0,21	0,40 - 1,20	0,35	0,040	0,040	
410 HD	killed and fine grained						0,020
460 HB	killed	0,22	0,80 - 1,40	0,35	0,040	0,040	
460 HD	killed and fine grained						0,020
510 HB	killed	0,22	0,60 - 1,80	0,35	0,035	0,035	
510 HD	killed and fine grained						0,020

(1) Nb, V or Ti may be used for grain refining as a complete or partial substitute for Al. The grain refining elements are to be specified at the time of approval; in general Nb and V are not to exceed 0,05 and 0,10%, respectively.
Additional alloying elements are to be submitted for consideration and approval. Residual elements not intentionally added are not to exceed the following limits (%): Ni $\leq 0,30$; Cu $\leq 0,25$; Cr $\leq 0,25$; Mo $\leq 0,10$. Total: Ni + Cu + Cr + Mo $\leq 0,70$

(2) For welded pipes, rimmed steel may also be used, as specified at the approval.

Table 3 : Mechanical properties (1/7/2004)

Steel grade	Yield stress R_{eH} (N/mm ²) min. for thickness t (mm)			Tensile strength R_m (N/mm ²)	Elong. A_5 (%) min.	Average impact energy (J) min.		Technological tests		
	t ≤ 16	16 < t ≤ 40	40 < t ≤ 60			Test temp (C°)	KVL	Flattening test constant C for t/D		Bend test diameter mandrel
								t/D ≤ 0,15	t/D > 0,15	
320HA	195			320 - 440	25	+20	27	0,09	0,08	4 t
360HA	235	225	215	360 - 500	24	+20				
360HB						0				
410HB	255	245	235	410 - 550	22	0	0,07	0,06		
410HD						-20				
460HB	285	275	265	460 - 580	21 (2)	0				
460HD						-20				
510HB	355	345	(1)	510 - 630	19 (2)	0	34			
510HD						-20				

(1) To be agreed between Manufacturer and purchaser.
(2) For pipes intended for oleodynamic cylinders manufactured in accordance with recognised standards, a minimum value of elongation of 16% may be accepted.

Table 4 : Chemical composition

Steel grade	Chemical composition (%) (1)								
	C max	Mn	Si	P max	S max	Cr	Mo	V	Al tot
320	0,16	0,40-0,70	≤ 0,35	0,030	0,030				
360	0,17	0,40-1,00	≤ 0,35	0,030	0,030				
410	0,21	0,40-1,20	≤ 0,35	0,030	0,030				
460	0,22	0,80-1,40	≤ 0,35	0,030	0,030				
510	0,22	0,60-1,80	≤ 0,35	0,035	0,035				
0,3Mo	0,12-0,20	0,40-0,80	0,10-0,35	0,035	0,035		0,25-0,35		≤0,020
0,5Cr 0,5Mo	0,10-0,18	0,50-0,90	0,10-0,35	0,035	0,035	0,40-0,65	0,45-0,60		≤0,020
1Cr 0,5Mo	0,10-0,18	0,40-0,70	0,10-0,35	0,035	0,035	0,70-1,10	0,45-0,65		≤0,020
2,25Cr 1Mo	0,08-0,15	0,40-0,70	0,10-0,35	0,035	0,035	2,00-2,50	0,90-1,20		≤0,020
0,5Cr 0,5Mo 0,25V	0,10-0,18	0,40-0,70	0,15-0,50	0,035	0,035	0,70-1,10	0,45-0,65	0,22-0,28	≤0,020

(1) Additional alloying elements are to be submitted for consideration and approval. Residual elements are permitted provided they do not impair the properties, subsequent processing or behaviour in service.
For C and C-Mn steels, the following limits (%) apply: Ni ≤ 0,30 ; Cu ≤ 0,25 ; C ≤ 0,25 ; Mo ≤ 0,10 ; Total: Ni+Cu+Cr+Mo ≤ 0,70. For Mo and Cr-Mo alloy steels, the limits are the following (%): Ni ≤ 0,30 ; Cu ≤ 0,25

4.2 Steel grades

4.2.1 The requirements apply to carbon, carbon-manganese steels and low alloy steels (Mo, Cr-Mo and Cr-Mo-V).

4.2.2 Carbon and carbon manganese steels are classed into four groups which are indicated by the minimum ultimate tensile strength R_m (N/mm²): 320, 360, 410, 460 and 510.

4.2.3 Low alloy steels are designated according to the chemical composition into the grades 0,3Mo - 0,5Mo0,5Cr, 1Cr0,5Mo - 2,25Cr1Mo - 0,5Cr0,5Mo0,25V.

The figures mean the nominal percentage content of the main alloying elements.

4.3 Condition of supply

4.3.1 The products are to be supplied in the conditions indicated in Tab 5.

Table 5 : Mechanical properties - Conditions of supply

Steel grade	Heat Treatment (1)	Yield stress R_{eH} (N/mm ²) min for t (mm)		Tensile strength R_m (N/mm ²)	Elong. A_5 (%) min.	Technological tests			
		t ≤ 40	40 < t ≤ 60			C (3)	Di/D (4)		
							≤ 0,6	0,6 < Di/D ≤ 0,8	> 0,8
320	N or NR	195		320 - 440	25	0,09	12	15	19
360	N or NR	225	215	360 - 500	25	0,09	12	15	19
410	N or NR	245	235	410 - 550	22	0,06	10	12	17
460	N or NR	270	260	460 - 580	21	0,06	8	10	15
510	N or NR	345	(2)	510 - 640	21	0,06	8	10	15
0,3Mo	N	270	260	450 - 600	22	0,07	8	10	15
0,5Cr 0,5Mo	N+T	270	260	440 - 570	22	0,07	8	10	15
1Cr 0,5Mo	N or N+T	290	280	440 - 590	22	0,07	8	10	15
2,25Cr 1Mo	N+T	280	270	450 - 600	20	0,06	8	10	15
	A	205	205	410 - 560	22	0,06	8	10	15
0,5Cr 0,5Mo 0,25V	N+T	300	290	460 - 610	20	0,06	8	10	15

(1) N : normalising - NR : normalising forming - T: tempering - A : annealing.
(2) To be agreed between Manufacturer and purchaser.
(3) Constant C for flattening test.
(4) Expanding or flanging test; increase of outside diameter D, in %, as a function of Di/D.

4.4 Chemical composition

4.4.1 The chemical composition on ladle analysis is to comply with the requirements specified in Tab 4.

Steels are to be killed with the exception of grades 320 and 360 which may be semi-killed.

4.5 Mechanical properties

4.5.1 The mechanical properties and conditions of supply are specified in Tab 5.

4.6 Mechanical properties at elevated temperatures

4.6.1 The values of the yield stress R_{eH} or 0,2% proof stress $R_{p0,2}$ at temperatures of 100°C and higher are given in Tab 6.

The values are for design purposes only. Their verification is in general not required during the testing, unless figures higher than those shown in Tab 6 and in accordance with recognised standards are proposed by the steel Manufacturer.

In such cases, the verification is required and the procedures detailed in [4.6.2] and [4.6.3] are to be followed.

4.6.2 When the $R_{p0,2}$ is required to be verified, at least one tensile test for each cast is to be carried out at the agreed temperature.

In cases of pipes of different thickness, the sample is to be taken from a pipe selected among those of greatest thickness.

The dimensions of the specimens and the testing procedure are to be in accordance with the requirements of Ch 1, Sec 2, [2.1.7] and Ch 1, Sec 2, [2.2.5] respectively.

The results of tests are to comply with the values specified in Tab 6.

4.6.3 As an alternative to the systematic verification of the required $R_{p0,2}$ as in [4.6.2], it may be agreed with the individual steelmakers to carry out an adequate program of tests on the normal production of each steel, in accordance with an ad hoc procedure.

Subsequent to the satisfactory results of the approval tests, tensile tests at elevated temperatures are not generally required during the routine testing of the material supplied but as a random check for the confirmation.

4.6.4 For design purposes only, the estimated values of the stress to rupture in 100000 hours are given in Tab 7 for groups of steels.

4.7 Mechanical and technological tests

4.7.1 For pipes intended for boiler headers, the tests are to be carried out on each as made length.

Other pipes are to be presented in batches and the number is defined in Tab 1.

Two pipes are to be selected from each batch for the required tests, as follows:

- a) seamless pipes and tubes:
 - one tensile test, longitudinal direction
 - one flattening test or one bend test
 - one expanding or flanging test, when required

b) welded pipes:

- one tensile test on base metal, longitudinal direction
- one tensile test transverse to the weld
- two flattening or two bend tests transverse to the weld for pipes with $D \geq 300$ mm
- one expanding or flanging test, when required.

When required in [4.6.1], a tensile test at elevated temperature is to be performed on one sample per cast.

5 Ferritic steel pipes for pressure service at low temperature

5.1 Application

5.1.1 The requirements of this Article apply to seamless and welded steel pipes intended for construction of piping systems, pressure vessels and plants, when impact properties at temperatures lower than -20°C are specified.

Provision is made for pipes with wall thickness up to 40mm.

5.2 Steel grades

5.2.1 The requirements apply to carbon and carbon-manganese steels and nickel alloy steels.

5.2.2 The carbon and carbon-manganese steels are classed into four groups which are indicated by the minimum ultimate tensile strength R_m (N/mm²): 360, 410, 460 and 510.

Each group is further subdivided into two grades LE and LF, based on the quality level and impact properties.

The letters LE and LF mean impact properties at -40°C and -60°C , respectively.

5.2.3 The Ni alloy steels are designated according to the chemical composition into the grades 3,5Ni, 9,0Ni.

The figures mean the Ni nominal percentage content.

5.3 Condition of supply

5.3.1 The pipes are to be supplied in the conditions indicated in Tab 9.

5.4 Chemical composition

5.4.1 The steel is to be killed and fine grained and the chemical composition on ladle analysis is to comply with the requirements specified in Tab 8.

Table 6 : Minimum proof stress ($R_{p0,2}$) values at elevated temperatures

Steel grade	$R_{p0,2}$ (N/mm ²) at a temperature ($^{\circ}\text{C}$) of (1)									
	100	150	200	250	300	350	400	450	500	550
320 HA	170	160	150	125	100	95	90	85		
360 HA	190	175	165	145	120	115	110	105		
410 HA	210	200	190	170	150	140	130	125		
460 HA	235	220	215	195	180	165	160	155		
510 HA	250	240	230	215	195	180	175	170		
0,3Mo	240	235	225	205	175	160	155	150	145	
0,5Cr 0,5Mo (2)										
1Cr 0,5Mo	265	250	245	235	190	180	175	165	155	150
2,25Cr 1Mo (3)	260	250	245	235	230	215	205	195	180	165
2,25Cr 1Mo (4)	110	100	90	85	80	75	70	65	65	70
0,5Cr 0,5Mo 0,25V	260	250	235	215	190	185	175	165	155	145

(1) The values for temperatures $<200^{\circ}\text{C}$ are given for information.
(2) Values to be determined during preliminary approval.
(3) Normalised and tempered condition.
(4) Annealed condition.

Table 7 : Average values for stress to rupture in 100000 hours (N/mm²)

Temperature (°C)	Carbon and carbon manganese steels		Alloy steels				
	360 / 410	460 / 510	0,3Mo	1Cr 0,5Mo	2,25Cr 1Mo		0,5Cr 0,5Mo 0,25V
					N + T (1) (3)	A (2)	
380	170	225					
390	155	200					
400	140	175					
410	125	155					
420	110	135					
430	100	115					
440	90	100					
450	75	85	240	280	220	195	
460	65	70	205	250	205	180	
470	55	60	175	220	185	165	
480	45	55	140	200	170	155	215
490	35	45	115	170	150	140	190
500		40	95	140	135	125	170
510			75	120	120	115	150
520			60	97	105	100	130
530			45	80	90	90	115
540			35	65	76	76	100
550			30	54	68	68	85
560				43	58	58	70
570				35	50	50	55
580					44	44	45

Note 1: The values shown are estimated average values; the lower limit of the range is approximately 20% less than the average value.

(1) N + T = normalising + tempering.
(2) A = annealing.
(3) When the tempering temperature exceeds 750°C, the values relevant to the annealing heat treatment are to be used.

Table 8 : Chemical composition

Steel grade	Chemical composition (%) (1)							
	C max	Mn	Si	P max	S max	Ni	Al tot	Others (3)
360 LE-LF	0,17	0,40 - 1,00	≤ 0,35	0,030	0,025	≤ 0,30 (2)	≥ 0,020	Cr ≤ 0,25 Cu ≤ 0,30 Mo ≤ 0,10
410 LE-LF	0,18	0,60 - 1,30	≤ 0,35	0,030	0,025	≤ 0,30 (2)	≥ 0,020	
460 LE-LF	0,18	0,60 - 1,30	≤ 0,35	0,030	0,025	≤ 0,30 (2)	≥ 0,020	
510 LE-LF	0,20	1,00 - 1,60	≤ 0,35	0,030	0,025	≤ 0,30 (2)	≥ 0,020	
3,5 Ni	0,15	0,30 - 0,90	0,15 - 0,35	0,025	0,020	3,25 - 3,75	-	
9,0 Ni	0,12	0,30 - 0,90	0,15 - 0,35	0,025	0,020	8,50 - 9,50	-	

(1) With the exception of refining elements, additional alloying elements are to be submitted for consideration and approval; residual elements are permitted provided they do not impair the properties, subsequent processing or behaviour in service.
(2) Higher Ni content up to 0,80 % may be agreed for LF grades.
(3) When the pipes are subjected to hot forming: Cu < 0,25.

Table 9 : Mechanical properties and condition of supply

Steel grade	Heat treatment (1)	Yield stress R_{eH} (N/mm ²) min. for t (mm)		Tensile strength R_m (N/mm ²)	Elong. A_5 (%) min.	Average impact energy (J) min.		Technological tests		
		≤ 25	25 < t ≤ 40			Test temp (°C)	KVL	Flattening test constant C for t/D		Bend test diameter mandrel
								t/D ≤ 0,15	t/D > 0,15	
360 LE	N	225	215	360-500	22	-40	27	0,09	0,08	4 t
360 LF						-60				
410 LE	N	255	245	410-550	20	-40	27	0,07	0,06	
410 LF						-60				
460 LE	N	275	265	460-580	20	-40	27			
460 LF						-60				
510 LE	N	345	335	510-630	19	-40	34			
510 LF						-60				
3,5 Ni	N or N+T or Q+T	255	245	450-640	19	-100	34			
9,0 Ni	N+N+T	470	460	640-840	16	-196	41			
9,0 Ni	Q+T	570	560	690-840						

(1) N: Normalising ; N+T: normalising and tempering ; N+N+T: double normalising and tempering ; Q+T: quenching and tempering.

5.5 Mechanical properties

5.5.1 The mechanical properties and conditions of supply are specified in Tab 9.

5.6 Mechanical and technological tests

5.6.1 The pipes are to be presented in batches and the number of pipes per batch is defined in Tab 1.

Two pipes are to be selected from each batch for the required tests, as follows:

- a) seamless pipes and tubes:
 - one tensile test, longitudinal direction
 - one flattening test or one bend test
 - 3 Charpy V-notch impact tests, longitudinal direction, for thickness ≥ 3 mm
- b) welded pipes:
 - one tensile test on base metal, longitudinal direction
 - one tensile test transverse to the weld
 - two flattening tests or two bend tests transverse to the weld for pipes with $D \geq 300$ mm
 - 3 Charpy V-notch impact tests, longitudinal direction, for thickness ≥ 3 mm.

6 Austenitic and austenitic-ferritic stainless steel pipes

6.1 Application

6.1.1 The requirements of this Article apply to seamless and welded austenitic and austenitic-ferritic stainless steel

pipes intended for use in the construction of piping systems conveying chemicals or liquefied gases.

6.1.2 Austenitic stainless steels are suitable for use at both elevated and low temperatures.

When austenitic stainless steels are proposed for use at elevated temperatures, details of chemical composition, heat treatment and mechanical properties are to be submitted for consideration and approval.

Ferritic austenitic (duplex) steels are suitable for use for service temperatures between -20°C and +275°C.

6.2 Steel grades

6.2.1 The requirements apply to Cr-Ni stainless steels.

Steels are designated according to AISI grades; the corresponding ISO grades are also indicated in Tab 10.

6.3 Condition of supply

6.3.1 The pipes are to be supplied in the solution treated condition.

6.4 Chemical composition

6.4.1 The chemical composition on ladle analysis is to comply with the requirements specified in Tab 10.

6.5 Mechanical properties

6.5.1 The mechanical properties are specified in Tab 11.

Table 10 : Chemical composition

ISO grade designation	AISI grade designation	Chemical composition (%) (1)								
		C max	Mn max	Si max	P max	S max	Cr	Ni	Mo	Others
X2CrNi1810	304L	0,03	2,00	1,00	0,045	0,035	17,0-19,0	9,0-13,0	-	
X5 CrNi1810	304	0,07	2,00	1,00	0,045	0,035	17,0-19,0	9,0-13,0	-	
X2CrNiMo1713	316L	0,03	2,00	1,00	0,045	0,035	16,0-18,5	11,0-14,0	2,0-2,5	
X5CrNiMo1713	316	0,07	2,00	1,00	0,045	0,035	16,0-18,5	11,0-14,0	2,0-2,5	
X6CrNiTi1810	321	0,08	2,00	1,00	0,045	0,035	17,0-19,0	9,0-13,0	-	5xC≤Ti≤0,80
X6CrNiNb1810	347	0,08	2,00	1,00	0,045	0,035	17,0-19,0	9,0-13,0	-	10xC≤Nb≤1,0
X2CrNiMoN2253	UNS31803	0,03	2,00	1,00	0,030	0,020	21,0-23,0	4,50-6,50	2,5-3,5	0,08≤N≤0,20

(1) Additional alloying elements are to be submitted for consideration and approval.
Residual elements are permitted provided they do not impair the properties, subsequent processing or behaviour in service of the material.

Table 11 : Mechanical properties

Steel grade	Yield strength (N/mm ²) min. (1)		Tensile strength R _m (N/mm ²)	Elong. A ₅ (%) min	Average impact energy KVL (J) at		C (2)	Technological tests		
	R _{p0,2}	R _{p1}			-196°C	-20°C		Di/D (3)		
								≤ 0,6	0,6 < Di/D ≤ 0,8	> 0,8
304L	175	205	460 - 690	30	41			9	15	17
304	195	235	460 - 690	30	41					
316L	185	215	460 - 690	30	41					
316	205	245	460 - 690	30	41		0,09			
321	195	325	510 - 710	30	41					
347	205	245	510 - 710		41					
UNS 31803	450		620	25		27				

(1) Conventional proof stress; the 0,2% proof stress values are given for information and, unless otherwise agreed, are not required to be verified during the test.
(2) Constant C for flattening test.
(3) Expanding or flanging test; increase of outside diameter D, in %, as a function of Di/D.

6.6 Mechanical and technological tests

6.6.1 (1/4/2009)

Unless they are required to be tested on each length, pipes are to be presented in batches, as specified in Tab 1.

Two pipes are to be selected from each batch for the required tests, as follows:

a) seamless pipes:

- one tensile test, longitudinal direction
- one flattening test or one bend test with mandrel diameter of 3 t
- 3 Charpy V-notch impact tests, longitudinal direction
- one expansion or flanging test, when required

b) welded pipes:

- one tensile test on base metal, longitudinal direction
- one tensile test transverse to the weld for pipes with $D \geq 300$ mm
- two flattening or two bend tests transverse to the weld with mandrel diameter of 3 t
- 3 Charpy V-notch impact tests, longitudinal direction, when required
- one expansion or flanging test when required.

When required, one tensile test at elevated temperature is to be performed on one sample per cast.

Unless otherwise required, impact tests on the austenitic grades are to be performed for design temperature lower than -105°C and are to be carried out at -196°C.

6.7 Corrosion tests

6.7.1 For materials used for piping systems for chemicals, the corrosion tests, ASTM A262 Practice E (Copper-copper sulphate sulphuric) or ASTM A262 Practice C (Nitric acid test), as appropriate, may be required to be carried out on two pipes per batch.

Tests in accordance with other recognised standards are accepted, subject to the agreement of the Society.

7 Fittings

7.1 Application

7.1.1 The requirements of this Article apply to seamless and welded carbon, carbon manganese, low alloy and alloy steel fittings, fabricated from pipes or plates and intended for piping systems or pressure plants.

7.2 Steel grades and relevant properties

7.2.1 Fittings fabricated from pipes are to meet the requirements of Articles [1] to [6], depending on the applications, with respect to manufacture, chemical composition and mechanical properties. Fittings may be hot or cold formed from sections of pipes.

Fittings fabricated from plates are to meet the requirements of the Articles from Sec 1, [1] to Sec 1, [7], depending on the applications, with respect to manufacture, chemical composition and mechanical properties.

Fittings may be made from sections of plates formed in one or more shells and welded together. The relevant welding process is to be approved.

7.2.2 Unless otherwise required, the material used for the fabrication of the fittings is to be covered by a works' certificate (W).

7.3 Condition of supply

7.3.1 All fittings are to be in the heat treated or hot working condition specified in the various Articles for the corresponding material.

Fittings in ferritic steel manufactured by hot forming may be delivered in the normalised forming condition in lieu of

normalising, provided that evidence is given of the equivalence of such condition; see [1.7.1].

Fittings manufactured by cold forming are in general to be submitted to heat treatment after forming.

A proposal to deliver fittings in the cold formed condition may be considered by the Society; to this end, the Manufacturer is to submit detailed information relevant to forming procedure, mechanical properties after forming and destination of the products.

The heat treatment procedure of welded fittings is to be defined during the approval tests.

7.4 Mechanical properties

7.4.1 The mechanical properties of the finished fittings are to comply with the values specified for the starting materials (plate or pipe).

7.5 Mechanical and technological tests

7.5.1 The fittings are to be presented for testing in batches homogeneous for cast and in the number indicated in Tab 1.

A Brinell hardness test HB is to be performed on 10% of the fittings, with a minimum of 3 units, to verify the homogeneity of the batch. The difference in the hardness value may not be greater than 30 units.

Two fittings per batch are to be selected for the mechanical and technological tests specified in Articles [2] to [6] depending on the application.

The tensile tests are to be performed on the hardest and softest fittings.

7.6 Non-destructive examination

7.6.1 Unless otherwise specified during the approval procedure or in the order, checks with radiographic examination are in general to be performed on welded fittings with outside diameter higher than 75 mm, at the Surveyor's discretion.

7.7 Marking and certification

7.7.1 The requirements specified in Article [1] relevant to marking in [1.10] and certification in [1.11] are to be complied with, as appropriate.

SECTION 3 STEEL FORGINGS

1 General

1.1 Application

1.1.1 General (1/7/2022)

The requirements of this Section apply to steel forgings intended for hull, structural applications, machinery, boilers, pressure vessels and piping systems.

These requirements may also be applied to the testing of semi-finished products, to be further processed by forging, and to rolled products, when these are acceptable in lieu of forged material. See Sec 1, [6].

This Article specifies the requirements common to all the above-mentioned steel products, while the appropriate specific requirements are indicated in Articles [2] to [9].

In the case of applications involving the storage and transport of liquefied gases in bulk and the use of gases or other low-flashpoint fuels, the additional requirements in App 6 apply.

1.1.2 Mass productions

For mass produced small forgings, the Manufacturer may adopt modified procedures for testing and inspection subject to the approval of the Society.

1.1.3 Special requirements

Special requirements may be specified in the case of applications intended for dangerous substances or for particularly severe service conditions.

In the case of applications involving the storage and transport of liquefied gases or fluids at low temperature in general, the appropriate requirements of Pt E, Ch 9, Sec 6 also apply.

1.2 Classification of forgings

1.2.1 For the purposes of this Section, forgings are divided into two Classes depending on their service:

- a) class 1: forgings intended for important applications, such as propeller and shaft line, highly stressed components of propulsion machinery and essential auxiliary machinery (turbine rotors, crankshafts, shafts, hubs, connecting rods, piston rods, cross heads, pinions and gear wheels), rudder stocks and tillers, anchors, cargo gear items subjected to severe stresses, components of pressure vessels and piping systems of class 1 as defined in Part C, etc.; forgings subject to the requirements in [1.1.3].
- b) class 2: forgings subject to testing not included in class 1.

1.3 Manufacture

1.3.1 Manufacturing process (1/7/2003)

The steel used in the manufacture of forgings is to be made by a process approved by the Society.

Adequate top and bottom discards of the ingots are to be made to ensure freedom from piping and harmful segregations in the finished forgings.

Hot forging, to be carried out within the temperature range specified, is to be gradual and uniform and extended, as far as possible, to the final dimensions of the piece.

The plastic deformation is to be such as to ensure soundness, uniformity of structure and satisfactory mechanical properties.

At an appropriate stage of manufacture, after completion of all hot working operations, forgings are to be suitably heat treated to refine the grain structure and to obtain the required mechanical properties.

1.3.2 Reduction ratio (1/7/2003)

The reduction ratio is to be calculated with reference to the average cross-sectional area of the cast material. Where the cast material is initially upset, this reference area may be taken as the average cross-sectional area after this operation.

Unless otherwise approved, for Class 1 forgings the total reduction ratio is to be at least:

- for forgings made from ingots or from forged blooms or billets, 3:1 where $L > D$ and 1,5:1 where $L \leq D$
- for forgings made from rolled products, 4:1 where $L > D$ and 2:1 where $L \leq D$
- for forgings made by upsetting, the length after upsetting is to be not more than one-third of the length before upsetting or, in the case of an initial forging reduction of at least 1,5:1, not more than one-half of the length before upsetting
- for rolled bars, 6:1.

L and D are the length and diameter, respectively, of the part of the forging under consideration.

1.3.3 Flame and arc-air shaping

The shaping of forgings or rolled slabs and billets by flame cutting, scarfing or arc-air gouging is to be undertaken in accordance with recognised good practice and, unless otherwise approved, is to be carried out before the final heat treatment. Preheating is to be employed when necessitated by the composition and/or thickness of the steel. For certain components, subsequent machining of all flame cut surfaces may be required.

1.3.4 Welding of forgings (1/7/2003)

When two or more forgings are joined by welding to form a composite component, the proposed welding procedure

specification is to be submitted for approval. Welding procedure qualification tests may be required.

1.4 Approval

1.4.1 (1/7/2003)

Class 1 forgings are to be made by a Manufacturer approved by the Society.

When the approval is not required, the Manufacturer is, in any event, to be recognised on a case-by-case basis.

Provisions on the matter are given in the "Rules for the approval of Manufacturers of materials".

1.5 Quality of materials

1.5.1 All forgings are to be free from surface or internal defects which would be prejudicial to their proper application in service.

The surface finish is to be in accordance with good practice and with any specific requirements of the approved plans or purchase order.

1.6 Visual and dimensional examination

1.6.1 Visual examination

All products are to be submitted by the Manufacturer to visual examination; where applicable this is to include the examination of internal surfaces and bores.

All class 1 forgings are also to be presented to the Surveyor for visual examination.

Unless otherwise stated, the visual examination of class 2 forgings by the Surveyor is not required.

1.6.2 Verification of dimensions

The verification of dimensions and tolerances is the responsibility of the Manufacturer.

Checks of dimensions for verification of compliance with the approved drawings are in general required for important forgings, to the Surveyor's satisfaction.

1.7 Non-destructive examination

1.7.1 General (1/7/2006)

When required by the applicable Parts of the Rules, the approved plans, the approved procedure of welded composite components or, in particular cases, the Surveyor, appropriate non-destructive tests are also to be carried out and the results reported by the Manufacturer.

All such tests are to be carried out by competent operators qualified according to the requirements of Ch 1, Sec 1, [3.6.4], using reliable and efficiently maintained equipment. The testing procedures, the extent of testing and the acceptance criteria are to be in accordance with the applicable requirements and are to be agreed with the Society.

IACS Recommendation No. 68 is regarded as an example of an acceptable standard.

The Manufacturer is to provide the Surveyor with a report confirming that the required examinations have been car-

ried out without revealing significant defects; details of the procedure are also to be indicated in the report.

1.7.2 Magnetic and liquid penetrant examination

Magnetic particle or liquid penetrant testing is to be carried out when the forgings are in the finished condition.

Where current flow methods are used for magnetisation, particular care is to be taken to avoid damaging machined surfaces by contact burns from the prods.

Unless otherwise agreed, these tests are to be carried out in the presence of the Surveyor.

1.7.3 Ultrasonic examination

Ultrasonic examination is to be carried out following the final heat treatment and at a stage when the forgings have been machined to a condition suitable for this type of examination.

Both radial and axial scanning are to be carried out, when appropriate for the shape and dimensions of the forging being examined.

Unless otherwise agreed, this examination is to be carried out by the Manufacturer, although Surveyors may request to be present in order to verify that it is performed in accordance with the agreed procedure.

1.8 Rectification of defects

1.8.1 Rectification of defects by grinding (1/7/2003)

Defects may be removed by grinding or by chipping and grinding provided the component dimensions are acceptable.

The resulting grooves are to have a bottom radius of approximately three times the groove depth and are to be blended into the surrounding surface so as to avoid any sharp contours. Complete elimination of the defective material is to be verified by magnetic particle testing or liquid penetrant testing.

1.8.2 Rectification of defects by welding (1/7/2003)

Repair by welding of forgings, except crankshaft, forgings may be permitted subject to the prior approval of the Society. In such cases, full details of the extent and location of the repair, the proposed welding procedure, heat treatment and subsequent inspection procedures are to be submitted for approval.

For the purpose of the acceptance of the proposed repairs, due consideration is to be given to the type, class and service conditions of the forging.

The forging Manufacturer is to prepare records of repairs and subsequent inspections traceable to each forging repaired. The records are to be presented to the Surveyor and attached to the testing documentation.

1.9 Condition of supply

1.9.1 (1/7/2003)

At an appropriate stage of manufacture, after completion of all hot working operations, forgings are to be suitably heat treated to refine the grain structure and to obtain the required mechanical properties.

Heat treatment is to be carried out in suitable furnaces. See Ch 1, Sec 1, [2.3.1].

If, for any reason, a forging is locally reheated or is subsequently heated for further hot working, the forging is to be submitted to a new heat treatment.

1.9.2 The acceptable heat treatment conditions are indicated in the Articles relevant to the various forged products. When more than one heat treatment condition is specified, the choice of the supply condition, unless otherwise required, is left to the Manufacturer; the condition of supply is always to be mentioned in the testing documentation.

1.9.3 When the heat treatment is quenching and tempering and the piece cannot be forged near the final dimensions and shape, it is to be worked by rough machining or flame cutting prior to being quenched and tempered.

1.9.4 (1/7/2003)

If a forging is locally reheated, or any straightening operation is performed after the final heat treatment, a subsequent stress relieving heat treatment may be required.

1.9.5 For surface-hardened forgings, full details of the proposed procedure and specification, including the heat treatment of the base material, are to be submitted for approval. The Manufacturer may be required to demonstrate, by tests, that the proposed procedure gives a uniform surface layer of the required hardness and depth [1.11.11] and that it does not impair the soundness and properties of the steel.

1.9.6 (1/7/2003)

The Manufacturer is to maintain records of heat treatment identifying the furnace used, furnace charge, date, temperature and time at temperature. The records are to be presented to the Surveyor on request.

1.9.7 (1/7/2015)

Where induction hardening or nitriding is to be carried out, forgings are to be heat treated at an appropriate stage to a condition suitable for this subsequent surface hardening.

1.9.8 (1/7/2015)

Where carburizing is to be carried out, forgings are to be heat treated at an appropriate stage (generally either by full annealing or by normalizing and tempering) to a condition suitable for subsequent machining and carburizing.

1.10 Pressure test

1.10.1 Forgings subjected to internal pressure are to be subjected to a hydraulic pressure test in compliance with the conditions laid down in the applicable parts of the Rules.

The test pressure is to be measured by means of a suitable calibrated pressure gauge.

The test is to be performed on the forging in the finished condition and before the application of any coating which may conceal the effect of the test.

Unless otherwise agreed, the test of class 1 forgings is to be carried out in the presence of the Surveyor.

A report confirming the satisfactory results of the pressure tests and indicating the relevant testing conditions is to be issued by the Manufacturer.

1.11 Sampling and testing

1.11.1 General (1/7/2003)

The requirements relevant to the type and number of tests to be carried out are indicated in the Articles relevant to the various products.

Test material, sufficient for the required tests and for possible re-test purposes, is to be provided with a cross-sectional area of not less than that part of the forging which it represents. It is to be taken from forgings in the supply condition except for forgings to be carburised and for those still to be hot worked and/or heat treated at the purchaser's.

For forgings to be carburised after machining, sufficient test material is to be provided both for preliminary tests after forging and for final tests after completion of carburising [5.7.1].

Except for components which are to be carburised or, for hollow forgings where the ends are to be subsequently closed, test material is not to be cut from a forging until all heat treatment has been completed.

For forgings to be hot worked and/or heat treated by the purchaser, the samples to be tested at the Manufacturer's works are to be forged and heat treated accordingly.

1.11.2 Individual testing

In the case of individual testing, the sample is to be integral with each forging and is to be taken from a suitable extension as specified in the various Articles and in accordance with Fig 1 to Fig 10.

Where one forging is subsequently divided into a number of components, all of which are heat treated together in the same furnace charge, this may be regarded for test purposes as one forging and the number of tests required is to be related to the total length and mass of the original multiple forging.

1.11.3 Batch testing (1/7/2003)

A batch testing procedure may be adopted in the case of normalized forgings with mass up to 1000kg each and quenched and tempered forgings with mass up to 500kg each. A batch is to consist of forgings of similar shape and dimensions, made from the same heat of steel, heat treated in the same furnace charge and with a total mass not exceeding 6 t for normalised forgings and 3 t for quenched and tempered forgings, respectively.

1.11.4 Batch testing for rolled products (1/7/2003)

When the use of rolled bars as a substitute for forging material is permitted for the construction by machining of small shafts, pins, bolts and similar items of a diameter generally not exceeding 250 mm, a batch testing procedure may be adopted and the batch composition is to be as follows:

a) class 1:

- material from the same rolled ingot or bloom provided that where this is cut into individual lengths,

these are all heat treated in the same furnace charge, or

- bars of the same diameter and heat, heat treated in the same furnace charge and with a total mass not exceeding 2,5 t.

b) class 2: materials of the same type of steel, of approximately the same size and subjected to the same heat treatment; the total mass of batch is not to exceed 4 t.

The test samples are taken from one or more pieces of the batch [1.11.6].

1.11.5 Homogeneity of the batch

Where a batch testing procedure is used, hardness tests may be required at the discretion of the Surveyors to check the homogeneity of the batch [1.11.10] d).

1.11.6 Sampling

The test samples are to have a cross-sectional area not lower than the part of the forging they represent and are to be located, as a rule, on the top ingot side.

In the case of individual testing [1.11.2], the number and position of samples necessary for the required tests are indicated in the Articles relevant to the various products.

In the case of batch testing [1.11.3], one sample at least is to be taken from the forging representative of the batch; where the number of pieces in the batch exceeds 20, two samples are to be taken.

A set of specimens is to be cut from each sample, for the execution of:

- one tensile test
- three Charpy impact tests V- or U-notch, when required in the Articles relevant to the various products.

1.11.7 Preparation of test specimens (1/7/2003)

Test specimens are to be cut from the samples with their principal axis mainly parallel (longitudinal tests) or mainly perpendicular (transverse test) to the principal direction of fibre deformation, as required in the Articles relevant to the various products.

Unless otherwise agreed, the longitudinal axis of the test specimens is to be located as follows:

- for thickness or diameter up to maximum 50mm, the axis is to be at the mid-thickness or the centre of the cross-section
- for thickness or diameter greater than 50mm, the axis is to be at one quarter thickness (mid-radius) or 80mm, whichever is the lesser, below any heat treated surface.

At the discretion of the Society, specimen locations in the section different from those above may be agreed in some cases, e.g. forgings of substantial diameter or thickness, specific steels or heat treatments; in such cases, the values required may be modified accordingly on a case-by-case basis, in consideration in particular of the metallurgical structure and the specimens representativeness with regard to the in-service stress conditions.

For the tensile test, preference is to be given to cylindrical specimens.

For impact test specimens the notch is, in general, to be machined on the side of the specimen perpendicular to the nearest outside surface of the forging or to its tangent in correspondence.

Hardness tests are generally be of the Brinell type.

For the preparation of test specimens and relevant testing procedure, reference is to be made to the applicable requirements of Ch 1, Sec 2.

1.11.8 Tensile test (1/7/2003)

The results of the tensile test at ambient temperature are to comply with the requirements of the appropriate Tables, or of the approved specification when steels other than those specified in these Rules are accepted.

The Tables give the minimum requirements corresponding to different strength levels but it is not intended that these values should necessarily be regarded as specific rule grades.

The strength levels are given in multiples of 40 N/mm² for C and C-Mn steels, and of 50 N/mm² for alloy steels.

Forgings may be supplied to any specified minimum tensile strength selected within the general limits specified but subject to any additional requirements of the relevant construction Rules.

Where it is proposed to use a steel with a specified minimum tensile strength intermediate to those given, corresponding minimum values for the other properties may be obtained by interpolation.

For the properties at elevated temperatures and their verification, when required, see [7.6].

1.11.9 Impact test (1/7/2003)

The average value of a set of 3 tests is to comply with the average value required.

Only one individual value may be lower than the average value required, provided that it is not less than 70% of it.

The minimum average values for impact tests are relevant to standard specimens 10x10mm².

1.11.10 Hardness tests (1/7/2003)

Unless otherwise specified, hardness tests may be required, to Surveyor's satisfaction, on the following items:

- quenched and tempered gear forgings after completion of heat treatment and prior to machining the gear teeth [5.6.2]
- surface-hardened gear forgings after the teeth have been ground to the finished profile [5.7.2]
- surface-hardened forgings in general
- batch tested forgings:
 - class 1 forgings: at least one hardness test on each forging
 - class 2 forgings: random checks only.

The results of hardness tests required under a) and d) are to be in agreement with the appropriate values given for information in Tab 6.

The results of hardness tests required under b) and c) are to comply with the approved specification.

1.11.11 Hardness checks on additional tests samples

When required by the conditions of approval for surface-hardened forgings, additional hardness checks are to be carried out on test samples processed at the same time as the forgings they represent. These test samples are subsequently to be sectioned in order to determine the hardness, shape and depth of the locally hardened zone, which are to comply with the approved specification.

1.11.12 Re-test procedures

Samples for possible re-tests are to be taken as near as practicable to the specimens used for the original tests; however, at the discretion of the Surveyors, they may also be taken from other positions or pieces deemed representative of the forging or batch.

Re-test procedures are specified in Ch 1, Sec 1, [3.5].

1.12 Identification and marking

1.12.1 (1/7/2003)

The Manufacturer is to adopt a system of identification which will enable all finished forgings to be traced to the original cast and their manufacturing and the Surveyor is to be given full facilities for so tracing the forgings when required.

All forgings which have been tested and inspected with satisfactory results are to be clearly marked by the Manufacturer with the following details:

- a) Manufacturer's name or trade mark
- b) Society's brand
- c) identification mark for the grade of steel
- d) cast number or other marking which will enable the history of the fabrication of the forging to be traced
- e) additional, optional marks such as file number and code of local inspection office, Surveyor's personal brand
- f) test pressure, where applicable.

Modified arrangements for identification and marking of small forgings manufactured in large numbers may be agreed with the Surveyor.

1.13 Documentation and certification

1.13.1 The testing documentation indicated in Ch 1, Sec 1, [4.2.1] is to be issued and is to include all the information, as appropriate.

The ladle analysis is to include the content of refining and alloying elements, as applicable.

Where applicable, the reports relevant to the non-destructive examination [1.7.1], weld repair [1.8.2] and pressure test [1.10.1] are to be enclosed with the testing documentation.

1.13.2 When the steel is cast in a mill other than that where the forgings are manufactured, the Surveyor is to be supplied with a steelmaker's certificate stating the manufacturing process, the grade of steel, the cast number and the relevant ladle analysis.

2 Forgings for hull and other welded structures in general

2.1 Application

2.1.1 (1/7/2003)

The requirements of this Article apply to carbon, carbon-manganese and alloy steel forgings intended for hull components, such as rudder stocks and pintles, or for hull structures, such as sternframes, rudder horns or other welded structures in general, where design and acceptance tests are related to mechanical properties at ambient temperature.

2.1.2 (1/7/2003)

Forgings intended for sternframes, rudder horns, rudder stocks, pintles, tillers, anchors, anchor shackles belong to class 1; unless otherwise specified, on a case-by-case basis, other forgings belong to class 2.

2.2 Steel grades

2.2.1 The grades are identified by the symbol FC (forgings in carbon and carbon-manganese steels), followed by a number indicating the minimum ultimate tensile strength R_m , in N/mm².

2.2.2 Where it is proposed to use alloy steels, the steel specification relevant to chemical composition, mechanical properties and heat treatment is to be submitted for approval.

2.2.3 (1/7/2003)

Limits on the specified mechanical properties are given in Pt B, Ch 10, Sec 1 for forgings intended for rudder stocks, pintles, rudder coupling keys and bolts.

2.3 Condition of supply

2.3.1 (1/7/2003)

The forgings are to be supplied in one of the following conditions, as required (see [1.9.2]):

- a) Carbon and C-Mn steel forgings
 - fully annealed
 - normalised
 - normalised and tempered
 - quenched and tempered
- b) Alloy steels forgings
 - quenched and tempered.

For all types of steel the tempering temperature is to be not less than 550°C.

Alternatively, alloy steel forgings may be supplied in the normalised and tempered condition, in which case the specified mechanical properties are to be agreed with the Society.

2.4 Chemical composition

2.4.1 (1/7/2003)

All forgings are to be made from killed or killed and fine grained steel, as required, and their chemical composition is to comply with the limits indicated in Tab 3 or, where applicable, the requirements of the approved specification.

The chemical composition is to be appropriate for the type of steel, dimensions and required mechanical properties of the forgings.

Forgings intended for welded construction may be required by the Society to be made from fine grained steel.

The chemical composition of each heat is to be determined by the Manufacturer on a sample taken preferably during the pouring of the heat. When multiple heats are tapped into a common ladle, the ladle analysis is to apply.

2.5 Mechanical properties

2.5.1 (1/7/2003)

The requirements for the yield stress, elongation and reduction of area are given, for the different strength levels, in Tab 4.

2.6 Mechanical tests

2.6.1 (1/7/2003)

In the case of individual testing [1.11.2], at least one test sample is to be taken for the required tests from the end of each forging.

Where a forging exceeds both 4 t in mass and 3 m in length, one test sample is to be taken from each end (these limits refer to the as forged mass and length but exclude the test material).

2.6.2 In the case of batch testing, the number of test samples is indicated in [1.11.3].

2.6.3 (1/7/2003)

The test specimens for 1 tensile and, when required, 3 Charpy V-notch impact tests are to be taken from each test sample.

The test specimens are to be cut in a longitudinal direction. At the discretion of the Manufacturer, the alternative directions shown in Fig 1, Fig 2 and Fig 3 may be used.

2.6.4 (1/7/2003)

For forgings operating at 0°C or lower temperature, which are not dealt with in this Article, the applicable requirements are stipulated on a case-by-case basis, depending on the design temperature, application and dimensions; see also Article [8]. Forgings intended for the structure of the poop are to be made of fine grained steel and impact tested on longitudinal Charpy V-notch specimens.

The impact energy is to be not lower than 27 J at 0°C.

Forgings intended for the rudder stock and pintles of ships with ice class notation are to be made of fine grained steel and impact tested on Charpy V-notch longitudinal specimens. The impact energy is to be not lower than 27 J at -20°C.

2.7 Non-destructive examination

2.7.1 An ultrasonic examination and magnetic particle inspection are to be carried out on class 1 forgings, when required by the construction Rules of the finished products, by the approved plans or, in specific cases, by the Surveyor.

3 Forgings for machinery, shafts and equipment

3.1 Application

3.1.1 (1/7/2003)

The requirements of this Article apply to carbon, carbon-manganese and alloy steel forgings, intended for use in the construction of machinery, shafts and equipment and/or not specifically dealt with in the other Articles of this Section and where design and acceptance tests are related to mechanical properties at ambient temperature.

Specific requirements for anchors are given in Ch 4, Sec 1, [1].

3.1.2 (1/7/2003)

Forgings intended for propeller shafts, intermediate and thrust shafts, hubs, piston rods, connecting rods, cross heads belong to class 1; unless otherwise specified on a case-by-case basis, other forgings belong to class 2.

3.2 Steel grades

3.2.1 The grades are identified by one of the symbols FC (forgings in carbon and carbon-manganese steels) or FA (forgings in alloy steels), followed by a number indicating the specified minimum tensile strength R_m in N/mm².

3.2.2 (1/7/2003)

Limits on the specified mechanical properties are given in Pt C, Ch 1, Sec 7 for forgings intended for main propulsion shafting.

3.3 Condition of supply

3.3.1 (1/7/2003)

The forgings are to be supplied in one of the following conditions, as required (see [1.9.2]):

- a) Carbon and C-Mn steel forgings
 - fully annealed
 - normalised
 - normalised and tempered
 - quenched and tempered
- b) Alloy steels forgings
 - quenched and tempered.

For all types of steel the tempering temperature is to be not less than 550°C.

Alternatively, alloy steel forgings may be supplied in the normalised and tempered condition, in which case the specified mechanical properties are to be agreed with the Society.

Where the specified minimum tensile strength exceed 700 N/mm², forgings in carbon manganese steel are to be supplied in the quenched and tempered condition only.

3.4 Chemical composition

3.4.1 General (1/7/2003)

All forgings are to be made from killed or killed and fine grained steel, as required, and their chemical composition

is to comply with the limits indicated in Tab 5 or, where applicable, the requirements of the approved specification.

The chemical composition is to be appropriate for the type of steel, dimensions and required mechanical properties of the forgings.

Forgings intended for welded construction may be required by the Society to be made from fine grained steel.

The chemical composition of each heat is to be determined by the Manufacturer on a sample taken preferably during the pouring of the heat. When multiple heats are tapped into a common ladle, the ladle analysis is to apply.

3.5 Mechanical properties

3.5.1 (1/7/2003)

The requirements for the yield stress, elongation and impact energy are given, for the different strength levels, in Tab 6.

3.6 Mechanical tests

3.6.1 (1/7/2003)

In the case of individual testing [1.11.2], at least one test sample is to be taken for the required tests from the end of each forging.

Where a forging exceeds both 4 t in mass and 3 m in length, one test sample is to be taken from each end (these limits refer to the as forged mass and length but exclude the test material).

3.6.2 In the case of batch testing, the number of test samples is indicated in [1.11.3].

3.6.3 (1/7/2003)

The test specimens for 1 tensile and, when required, 3 Charpy V- notch impact tests are to be taken from each test sample in accordance with Fig 1, Fig 2 and Fig 3.

The specimens are to be taken in a longitudinal direction (position A). At the discretion of the Manufacturer, the alternative directions or positions B, C and D may be used.

Figure 1 : Plain shaft

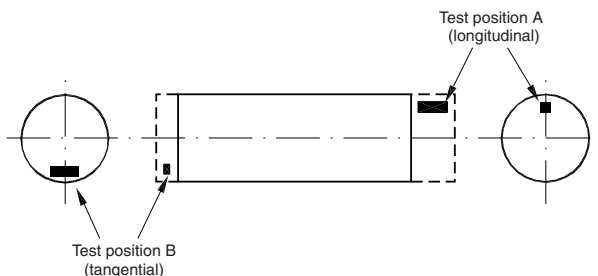

Figure 2 : Flanged shaft

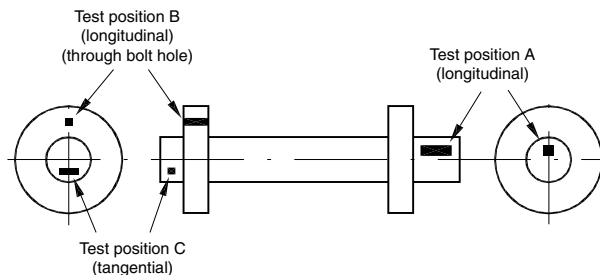
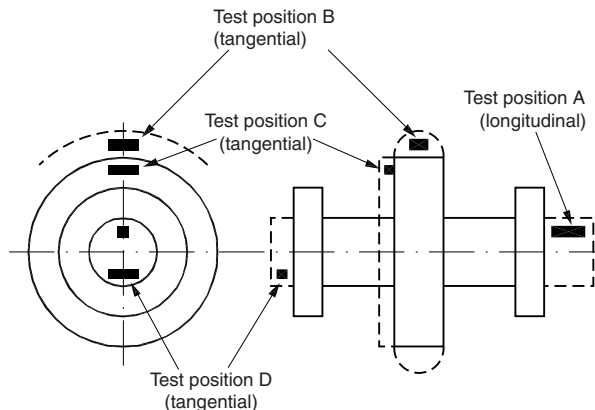

Figure 3 : Flanged shaft with collar



3.6.4 (1/7/2003)

For forgings operating at 0°C or lower temperature, the applicable requirements are to be stipulated on a case-by-case basis, depending on the design temperature, application and dimensions. See also Article [8].

Forgings intended for propeller shafts of ships with ice class notation are to be made of killed or killed and fine grained steel, as required, and the average impact energy is to be not lower than 27 J at the following temperatures for the different notations:

- 0°C for ships with notations IC
- 10°C for ships with notations IAS, IA or IB.

3.7 Non-destructive examination

3.7.1 A magnetic particle or liquid penetrant examination is to be carried out on forgings intended for:

- rudder stocks and pintles with diameter not lower than 100 mm
- main propulsion shafting with diameter not lower than 100 mm
- connecting rods
- components for engines having bore diameter larger than 400 mm, such as:
 - cylinder covers, piston crowns, piston rods, tie rods, gear wheels for camshaft drives
 - bolts and studs for cylinder covers, cross heads, main bearing and connecting rod bearings, nuts for tie rods.

Magnetic particle or liquid penetrant tests are to be carried out in positions mutually agreed upon by the Manufacturer

and the Surveyor, where experience shows defects are most likely to occur.

The magnetic particle test of tie rods/stay bolts is to be carried out at each threaded portion which is at least twice the length of the thread.

3.7.2 Ultrasonic testing is to be carried out on the following items:

- rudder stocks and pintles with diameter not lower than 200 mm
- shafts having a finished diameter of 200 mm or larger, when intended for main propulsion or other essential services
- piston crowns and cylinders covers
- piston and connecting rods with connecting rod bearing caps, for engines having a bore diameter greater than 400 mm.

3.8 Additional approval tests of alloy steel used for intermediate shafts

3.8.1 Application (1/1/2017)

This procedure is to be applied the approval of alloy steel which has a minimum specified tensile strength greater than 800 N/mm², but less than 950 N/mm intended for use as intermediate shaft material.

3.8.2 Torsional fatigue test (1/1/2017)

A torsional fatigue test is to be performed to verify that the material exhibits similar fatigue life as conventional steels. The torsional fatigue strength of said material is to be equal to or greater than the permissible torsional vibration stress, τ_1 , τ_2 given by the formulae in Pt C, Ch 1, Sec 9, [3.5.3].

The test is to be carried out with notched and unnotched specimens respectively. For calculation of the stress concentration factor of the notched specimen, fatigue strength reduction factor β should be evaluated in consideration of the severest torsional stress concentration in the design criteria.

3.8.3 Test conditions (1/7/2022)

Test conditions are to be in accordance with Tab 1. Mean surface roughness is to be <0.2 μ m Ra with the absence of localised machining marks verified by visual examination at low magnification (x20) as required by Section 8.4 of ISO 1352:2011.

Test procedures are to be in accordance with Section 10 of ISO 1352:2011.

Table 1 : Test condition (1/1/2017)

Loding type	Torsion
Stress ratio	R = 1
Load waveform	Constant-amplitude sinusoidal
Evaluation	S-N curve
Number of cycles for test termination	1 x 10 ⁷ cycles

3.8.4 Acceptance criteria (1/1/2017)

Measured high-cycle torsional fatigue strength τ_{c1} and low-cycle torsional fatigue strength τ_{c2} are to be equal to or greater than the values given by the following formulae:

$$\tau_{c1} \geq \tau_{1,\lambda=0} = C_R \cdot C_K \cdot C_D$$

$$\tau_{c2} \geq 1,7 \cdot \frac{1}{\sqrt{C_K}} \cdot \tau_{c1}$$

where:

C_R : material factor, see Pt C, Ch 1, Sec 9

C_K : factor for the particular shaft design features, see Pt C, Ch 1, Sec 9

C_D : size factor, see Pt C, Ch 1, Sec 9

3.8.5 Cleanliness requirements (1/7/2022)

The steels are to have a degree of cleanliness as shown in Tab 2 when tested according to ISO 4967:2013 method A. Representative samples are to be obtained from each heat of forged or rolled products.

The steels are generally to comply with the minimum requirements of Tab 2, with particular attention given to minimising the concentrations of sulphur, phosphorus and oxygen in order to achieve the cleanliness requirements. The specific steel composition is required to be approved by the Society.

Table 2 : Cleanliness requirements (1/1/2017)

Inclusion Group	Series	Limiting chart diagram index I
Type A	Fine	1
	Thick	1
Type B	Fine	1,5
	Thick	1
Type C	Fine	1
	Thick	1
Type D	Fine	1
	Thick	1
Type DS	-	1

3.8.6 Inspection (1/1/2017)

The ultrasonic testing required in [3.7.2] is to be carried out prior to acceptance. The acceptance criteria are to be in accordance with IACS Recommendation No. 68 or a recognized national or international standard.

4 Forgings for crankshafts

4.1 Application

4.1.1 The requirements of this Article apply to carbon-manganese and alloy steel solid forged crankshafts and

forgings to be used for the construction of semi-built or fully built crankshafts.

The general requirements, specified in Article [1], are also to be complied with, as appropriate.

4.1.2 Forgings intended for crankshafts belong to class 1.

4.2 Steel grades

4.2.1 The steel specification relevant to chemical composition, mechanical properties and heat treatment is to be submitted for approval.

4.2.2 The specified minimum tensile strength R_m is generally to be not lower than 400N/mm² and not higher than 1000N/mm², as required in Pt C, Ch 1, Sec 2, [4.1.1].

4.3 Manufacture

4.3.1 Continuous grain flow forging procedures are to be specially approved and, to this end, tests effected to demonstrate that a satisfactory structure and grain flow are obtained.

In the case of a welded crankshaft, the welding procedure is to be approved.

When the webs are obtained by flame cutting from forged or rolled flat products, the part to be removed by machining is to be not less than 8 mm from all flame-cut surfaces.

4.4 Condition of supply

4.4.1 Forgings are to be normalised and tempered or quenched and tempered depending on the approved specification.

The tempering temperature is to be not lower than 550°C.

4.4.2 Where a superficial hardening of the crankshaft forging by nitriding or by induction quenching is foreseen, full details of the proposed procedure are to be submitted as indicated in [1.9.5].

4.5 Chemical and mechanical properties

4.5.1 The chemical composition is to be in compliance with the approved specification [4.2.1].

For alloy steels which are to be nitrided, the phosphorus or sulphur content is to be not greater than 0,020%.

4.5.2 The minimum requirements for mechanical properties are indicated in Tab 6; see also [4.2.2].

4.6 Mechanical tests

4.6.1 (1/7/2003)

For solid open die forged crankshafts one set of tensile test specimens is to be taken in the longitudinal direction, from the driving shaft end of each forging (test position A in Fig 4).

Where the mass (as heat treated but excluding test material) exceeds 3 t, the specimens in a longitudinal direction are to be taken from each end (test positions A and B in Fig 4).

Where the crank throws are formed by machining or flame cutting, the second set of specimens is to be taken in the tangential direction from material removed from the crankthrow at the end opposite to the driving shaft end (test position C in Fig 4).

4.6.2 For crank webs, one set of specimens is to be taken from each forging in the tangential direction (test position C in Fig 4).

4.6.3 (1/7/2003)

For closed die crankshafts and crankshaft forgings where the method of manufacture has been specially approved in accordance with [4.3.1], the number and position of the specimens for mechanical tests are specified at the time of approval of the method of manufacture.

4.6.4 When small crankshaft forgings are batch tested [1.11.3], hardness tests are to be made on the individual pieces.

Figure 4 : Solid forged crankshaft

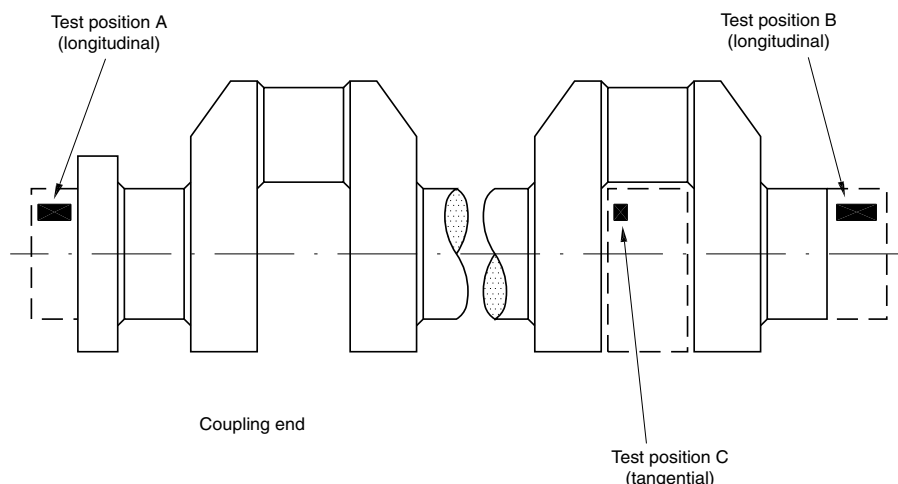

4.7 Non-destructive examination

4.7.1 Magnetic particle and/or liquid penetrant tests are required for all crankshaft forgings.

Where applicable, this is also to include all flame-cut surfaces not subsequently machined.

Special care is to be devoted to the pins and journals and associated fillets.

Unless otherwise agreed, all crankshaft forgings having a minimum crankpin diameter not lower than 150 mm are to be ultrasonically examined.

4.7.2 Non-destructive examination procedures and the acceptance criteria of the indications of such tests, complying with the requirements of the engine Manufacturer, are to be previously approved by the Society.

5 Forgings for gearing

5.1 Application

5.1.1 The requirements of this Article apply to carbon-manganese and alloy steel forgings intended for the construction of gearing for main propulsion and auxiliary equipment.

The general requirements, specified in Article [1], are also to be complied with, as appropriate.

5.1.2 Forgings intended for pinions and gear wheels belong to class 1.

5.1.3 In the case of forgings for flexible couplings, quill shafts and gearwheel shafts, the requirements of Article [3] apply.

5.2 Steel grades

5.2.1 Steels are to comply with requirements specified in [3.2] or with a specification approved by the Society.

To this end, a detailed specification relevant to chemical composition, mechanical properties and heat treatment is to be submitted for approval.

5.2.2 Limits on the specified minimum tensile strength are given in Pt C, Ch 1, Sec 6, depending on heat treatment condition.

5.3 Manufacture

5.3.1 (1/7/2003)

The reduction ratio during forging is to be in compliance with [1.3.2].

Forgings are to be provided on the surfaces with excess material sufficient as may be necessary for machining out possible defective zones.

5.4 Condition of supply

5.4.1 The conditions of supply are indicated in the approved specification of the product; unless otherwise specified therein, the conditions indicated in [5.4.2] apply.

5.4.2 (1/7/2003)

Forgings which are not to be surface-hardened are to be normalised and tempered or quenched and tempered; the tempering temperature is allowed to be lower than 550°C.

Forgings which are to be carburised are to be in either the "fully annealed" or the "normalised and tempered" condition, suitable for the subsequent operations.

Forgings which are to be induction hardened or nitrided, in the appropriate stage of manufacture when the surface hardening is done, are to be heat treated to a condition adequate for such operations.

5.4.3 Treatments for surface hardening are to be approved in accordance with [1.9.5].

5.5 Chemical and mechanical properties

5.5.1 The chemical composition and the mechanical properties are specified in [3.4] and [3.5], respectively, or in the approved specification; see also [5.2.1].

5.6 Mechanical tests for normalised and tempered or quenched and tempered forgings

5.6.1 Sampling (1/7/2003)

The specimens necessary for the required tests are to be taken from each forging [1.11.2] or a forging representative of the batch [1.11.3], in accordance with Fig 5, Fig 6, Fig 7 and Fig 8.

The set of test specimens is to be taken as follows:

- Pinions (see Fig 5):

Where the finished machined diameter of the toothed portion exceeds 200 mm, one set of test specimens is to be taken from each forging in the tangential direction adjacent to the toothed portion (test position B). Where the dimensions preclude the preparation of tests from this position, tests in the tangential direction are to be taken from the end of the journal (test position C).

If, however, the journal diameter is equal to or less than 200 mm, tests are to be taken in a longitudinal direction (test position A).

Where the finished length of the toothed portion exceeds 1,25 m, one set of test specimens is to be taken from each end.

Where the finished diameter of the toothed portion is equal to or less than 200 mm, one set of test specimens is to be taken in a longitudinal direction (test position A).
- Gear wheel (see Fig 6):

One set of tests is to be taken from each forging in a tangential direction (test positions A or B).
- Gear wheel rims made by expanding (see Fig 7):

One set of tests is to be taken from each forging in the tangential direction (test position A). Where the finished diameter exceeds 2,5 m or the mass (as heat treated excluding test material) exceeds 3 t, two sets of test

specimens are to be taken from diametrically opposite positions (test positions A and B).
The mechanical properties for longitudinal testing are to be applied.

- Pinion sleeves (see Fig 8):
One set of test specimens is to be taken from each forging in the tangential direction (test position A). Where the finished length exceeds 1,25 m, one set of test specimens is to be taken from each end.

Figure 5 : Pinions

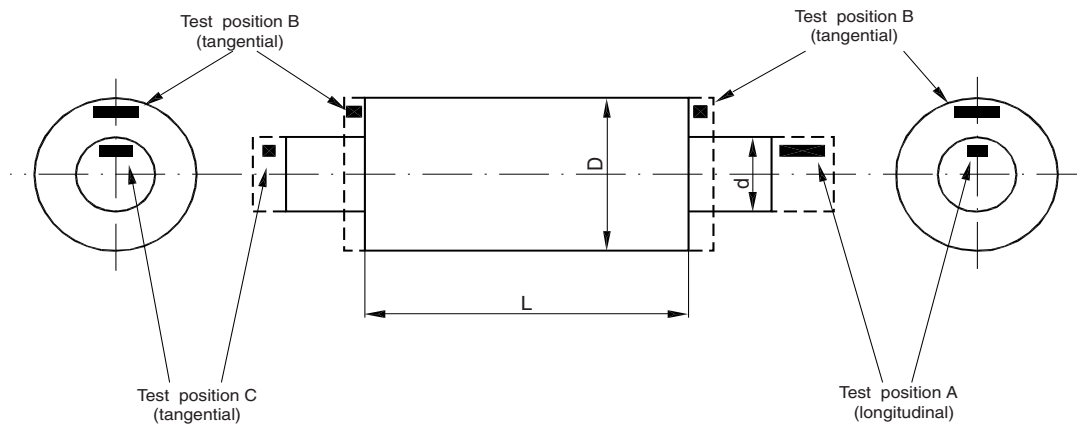

- L : length of toothed portion, in mm
- D : diameter of toothed portion, in mm
- d : journal diameter, in mm.

Figure 6 : Gear wheel

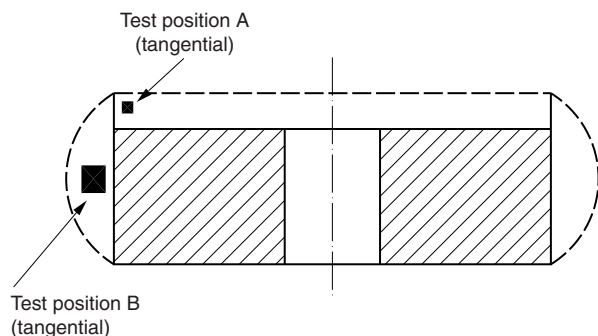

Figure 8 : Pinion sleeve

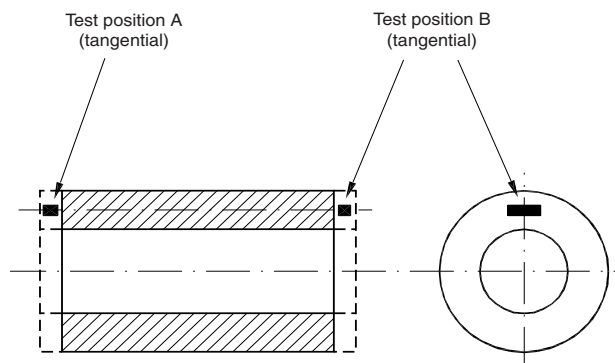
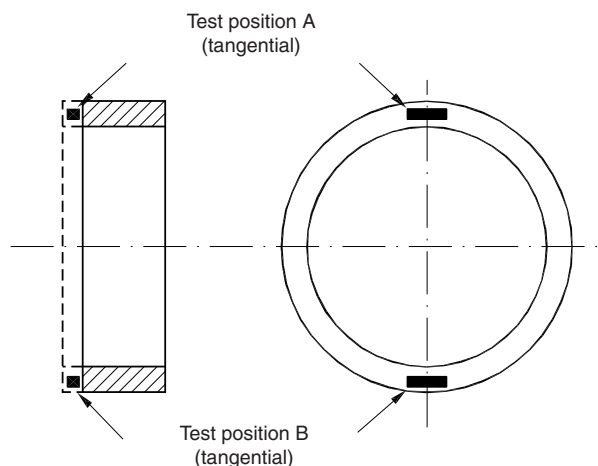

Figure 7 : Gear wheel rim made by expanding



5.6.2 Hardness tests (1/7/2003)

Hardness tests may be required generally as verification of the homogeneity, at the discretion of the Surveyors. See also [1.11.10] a).

The hardness is to be determined after completion of heat treatment and prior to machining the gear teeth.

Measurements are to be carried out at four positions equally spaced around the circumference of the surface where teeth will subsequently be cut. Where the finished diameter of the toothed portion exceeds 2,5m, the above number of test positions is to be increased to eight.

Where the width of a gear wheel rim forging exceeds 1,25 m, the hardness is to be determined at eight positions at each end of the forging.

When small gear forgings are batch tested ([1.11.3]), hardness tests are to be made on the individual pieces.

5.7 Mechanical tests for surface-hardened forgings

5.7.1 Sampling (1/7/2003)

Forgings to be carburised are to be provided with sufficient test material for the sets of specimens for both preliminary tests at the forge and final tests after completion of carburising.

The set of specimens consists of 1 tensile test specimen.

For this purpose duplicate sets of test material are to be taken from positions as detailed in [5.6.1] except that, irrespective of the dimensions or the mass of the forging, the tests are required from one position only and, in the case of forgings with integral journals, the material is to be cut in a longitudinal direction.

This test material is to be machined to a diameter of $D/4$ or 60 mm, whichever is the lesser, where D is the finished diameter of the toothed position.

For preliminary tests at the forge, the test material is to be given a blank carburising and heat treatment cycle, simulating the one which will be subsequently applied to the forging.

For final acceptance tests, the test material is to be blank carburised and heat treated together with the forgings which it represents.

At the discretion of the Manufacturer, test samples of larger cross-section may be either carburised or blank carburised, but they are to be machined to the required diameter prior to the final quenching and tempering treatment.

Alternative procedures for testing of forgings which are to be carburized may be specially agreed with the Society.

5.7.2 Hardness tests and additional checks

Hardness tests may also be required on forgings which have been induction hardened, nitrided or carburised. See also [1.11.10] b).

The hardness is to be determined on the toothed part after the teeth have been ground to the finished profile. The results of such tests are to comply with the approved specification.

Additional checks [1.11.11] of the hardness, depth and shape of the hardened layer are to be performed as indicated in the approved specification.

When, for nitrided gearing, hardness verification is required on additional test samples, unless otherwise stated in the approved specification the depth of the hardened zone is to be not lower than 0,5 mm and the hardness at a depth of 0,25 mm is to be not lower than 500 Vickers points.

5.8 Non-destructive examination

5.8.1 Magnetic particle or liquid penetrant testing is required on the tooth surfaces of gears hardened completely or at their surface.

An ultrasonic examination of the forgings is to be performed by the Manufacturer when there is still an adequate amount

of excess material on the surfaces in respect of the final position of the teeth.

In general, ultrasonic examination is required for forging having a finished diameter, of the part where teeth will be cut, higher than 200 mm.

6 Forgings for turbines

6.1 Application

6.1.1 The requirements of this Article apply to steel forgings intended for the construction of rotors and discs of main turbines and rotors of auxiliary turbines driving electric generators and compressors.

The general requirements specified in Article [1] are also to be complied with, as appropriate.

6.1.2 Forgings intended for propulsion machinery or essential auxiliary systems belong to class 1.

6.1.3 Plans submitted for approval are to state whether the turbine is for propulsion or for auxiliary service; in the latter case the shaft power is to be specified.

For rotors to be subjected to a thermal stability test, the maximum service temperature and the proposed test temperature are also to be specified.

For rotors of welded construction, the chemical composition of the steel is to be approved.

6.2 Steel grades, chemical composition and mechanical properties

6.2.1 The steel grades and relevant properties may be in accordance with [3.2], [3.4] and [3.5] or with a particular specification to be submitted for acceptance.

6.3 Condition of supply

6.3.1 The intermediate and final heat treatments, specified by the Manufacturer, are to be submitted for consideration.

In particular, the heat treatments are to be such as to avoid hair-line cracks.

For rotors of welded construction, the heat treatment is to be specially approved.

6.4 Mechanical tests

6.4.1 (1/7/2003)

For rotors not exceeding 3 t in mass, one set of longitudinal tensile specimen is to be taken from one end of the shaft and one set of test specimen is to be taken in the tangential direction from the body portion (see Fig 9).

For rotors exceeding 3 t in mass, the set of longitudinal specimens is to be taken from each end of the shaft and the set of tangential test specimens is to be taken from the body portion (see Fig 9).

For each turbine disc, at least one set of specimens is to be taken from the boss in the tangential direction (see Fig 10).

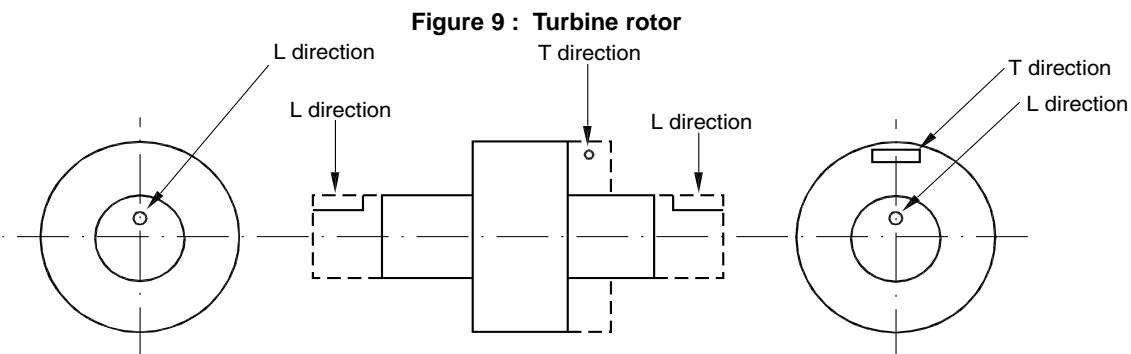
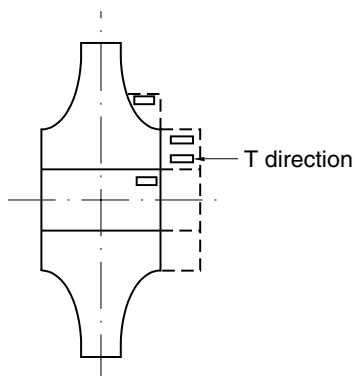

Figure 10 : Turbine disc



6.5 Non-destructive examination

6.5.1 A visual examination, supported by a magnetic particle examination at the discretion of the Surveyor, is required for the end surfaces of the rotors and the boss of the discs; the degree of finishing is to be appropriate for this purpose. An ultrasonic examination is to be carried out by the Manufacturer on all forgings.

6.5.2 Rotor forgings for propulsion turbines having a power exceeding 1100 kW are to be hollow bored to permit internal examination visually and, where possible, by the magnetic particle method.

These examinations are to be confirmed by the Surveyor; the degree of finishing is to be adequate for the purpose.

At the discretion of the Society, ultrasonic examination of the rotor by an approved procedure may be accepted as an alternative to hollow boring.

6.6 Thermal stability test

6.6.1 Solid forged rotors and rotors built by welding two or more forged pieces and intended for turbines having a service temperature exceeding 400°C are to be subjected, after the final heat treatment and in their rough machined condition, to a thermal stability test.

The test is to be performed using procedures and equipment to the satisfaction of the Society.

The deflection may be measured with the procedure outlined below, which consists in reading the radial elongation in way of some machined zones distributed along the length of the rotor (in general, there will be two reference machined zones in way of, or in proximity, of the supports and

three test machined zones located one at the mid-length and two at the ends of the rotor).

Four markings, 90° apart, are to be stamped for identification on the coupling end of the rotor.

During the test, the rotor is to be rotated very slowly and uniformly in the furnace, while it is heated gradually and evenly, excessive thermal gradients being avoided; the rotor is to be maintained for a sufficient length of time at the specified test temperature, which is to be appropriate to the final heat treatment of the piece, and subsequently slowly and uniformly cooled to a sufficiently low temperature, excessive thermal gradients again being avoided.

In the course of the test, the deflections are to be regularly recorded in each machined zone, at angular intervals of 90°, and the difference in the readings between the cold and hot conditions is not to exceed the specified limits.

In general, the following requirements are to be complied with:

- the furnace is to be large enough to contain the whole length of the rotor, including the end zones in way of the glands; overhung wheels, when present, are also to be enclosed in the furnace
- means are to be provided for continuous recording of the temperature at the surface of the rotor and, if practicable, in a bore at the mid-length of the rotor
- the temperature of the rotor is in no case to exceed the final tempering temperature
- the test temperature is to not be less than the maximum service temperature +28°C but not higher than the temperature mentioned above; the temperature distribution is to be uniform and maintained at a constant level for at least three hours with the readings falling within 0,006 mm in all the machined zones
- the rotor is to be rotated during cooling until the temperature is not more than 100°C
- cold readings are to be taken before and after the test.

The test results are considered satisfactory when the difference between the final readings in the hot conditions and the initial and final cold readings do not exceed 0,025 mm in any zone.

Otherwise, at the request of the Manufacturer and with the Society's approval, the test may be repeated; when the results of the second test are also unsatisfactory, proposals for alterations to the rotor are to be approved by the Society before further testing.

7 Forgings for boilers, pressure vessels and systems

7.1 Application

7.1.1 The requirements of this Article apply to weldable forgings made from carbon, carbon-manganese, molybdenum and chromium-molybdenum low alloy steels, intended for the construction of boilers and pressure vessels, plants and piping systems in general, when impact properties at temperature not lower than -20°C are specified.

For forgings not subjected to welding, the requirements of Article [2] apply, as appropriate.

7.1.2 Forgings intended for pressure vessels and piping systems of class 1, as defined in Part C, belong to class 1. Unless otherwise required on a case-by-case basis, the other forgings belong to class 2.

7.1.3 Forgings intended for vessels and systems operating at low temperatures are to comply with the applicable requirements of Article [8] and, in the case of applications involving the storage and transport of liquefied gases, with those specified in Pt E, Ch 9, Sec 6.

7.2 Steel grades

7.2.1 Carbon and carbon-manganese steels are classed into three groups indicating the minimum ultimate tensile strength R_m , in N/mm^2 : 410, 460 and 510.

Each group may be further subdivided into grades HA, HB and HD, based on conventional levels of quality and impact properties.

7.2.2 Low alloy steels are designated according to the chemical composition in the grades 0,3Mo-1Cr0,5Mo-2,25Cr1Mo.

The figures mean the nominal percentage content of the main alloying elements.

Where it is proposed to use steels other than those dealt with in these Rules, the steel specification relevant to chemical composition, mechanical properties and heat treatment is to be submitted for approval.

7.3 Condition of supply

7.3.1 Forgings are to be supplied in one of the following conditions, as required by the steel specification (see [1.9.2]):

- a) carbon and carbon-manganese steels:
 - normalised
 - normalised and tempered
 - quenched and tempered
- b) alloy steels:
 - normalised and tempered
 - quenched and tempered.

For all types of steel the tempering temperature is to be not lower than 550°C .

7.4 Chemical composition

7.4.1 The chemical composition on ladle analysis is to comply with the limits specified in Tab 7 for carbon and carbon-manganese forgings and Tab 8 for Cr and Cr-Mo alloy steel forgings.

7.5 Mechanical properties

7.5.1 The mechanical properties are specified in Tab 9 for carbon and carbon-manganese steel and in Tab 10 for Cr and Cr-Mo alloy steel forgings.

7.6 Mechanical properties at elevated temperature

7.6.1 The values for the 0,2% proof stress ($R_{p0,2}$) at temperatures of 150°C and higher are given in Tab 11.

The above values are for design purposes only. Their verification is in general not required during the testing, unless figures higher than those shown in Tab 11 and in accordance with recognised standards are proposed by the steel Manufacturer.

In such cases, the verification is required and the procedures detailed in [7.6.2] and [7.6.3] are to be followed.

7.6.2 When $R_{p0,2}$ is required to be verified, at least one tensile test for each cast is to be carried out at the agreed temperature on each forging or batch of forgings.

The test specimen is to be taken near the position of the tensile specimen tested at ambient temperature.

The dimensions of the specimens and the testing procedure are to be in accordance with the requirements of Ch 1, Sec 2, [2.1] and Ch 1, Sec 2, [2.2.5], respectively.

The results of tests are to comply with the specified values.

7.6.3 As an alternative to the systematic verification of the required $R_{p0,2}$ as in [7.6.2], it may be agreed with the individual steelmakers to carry out an adequate program of tests or to adequately check the statistical data of the current production.

7.6.4 The values of the estimated average stress to rupture in 100.000 hours are given, for design purposes only, in Sec 1, Tab 21.

7.7 Mechanical tests

7.7.1 With the exception of drums (see [7.7.2]), at least one set of specimens for mechanical tests (1 tension and unless otherwise required 3 Charpy V-notch specimens for type HB and HD) is to be taken from each forging [1.11.2] or batch [1.11.3]; unless otherwise agreed and when possible, specimens are to be taken in the longitudinal direction.

7.7.2 For drum forgings, one set of specimens for mechanical tests is to be taken from each open end.

When, depending on the manufacturing procedure, the test samples are to be detached before heat treatment, they are to be heat treated with the forging they represent.

The specimens are to be cut in the circumferential direction. Where the tensile test is carried out on specimens taken at both ends of a drum forging, the variation in tensile strength R_m on the two tests is not to exceed 70 N/mm².

7.7.3 For tensile tests at elevated temperatures, the requirements of [7.6.2] apply.

7.8 Non-destructive examination

7.8.1 Unless otherwise required or agreed, at least the following non-destructive examinations are to be carried out:

- all class 1 forgings are to be examined by the magnetic particle method
- all class 1 drum forgings and other similar important forgings having thickness higher than 10 mm are to be examined by ultrasonic method.

8 Ferritic steel forgings for low temperature service

8.1 Application

8.1.1 The requirements of this Article apply to ferritic steel forgings intended for welded structural use as in the construction of structures, vessels, plants and piping systems for low temperature service or when, irrespective of the service conditions, they are required to satisfy specified impact properties at temperatures lower than -20°C.

8.1.2 Unless otherwise agreed, forgings covered by this Article belong to class 1.

8.1.3 In the case of applications involving the storage and transport of liquefied gases or fluids at low temperature in general, the appropriate requirements of Pt E, Ch 9, Sec 6 also apply.

8.2 Steel grades and relevant properties

8.2.1 The requirements apply to carbon, carbon-manganese and nickel alloy steels.

The steel specification relevant to chemical composition, mechanical properties and heat treatment is to be submitted for approval.

Reference can be made to the steel designation, chemical composition and mechanical properties relevant to the rolled materials to which the forgings are intended to be welded, i.e. in particular, for these Rules, to Sec 1, Tab 22 and Sec 1, Tab 24 for carbon and carbon-manganese steels, and to Sec 1, Tab 23 and Sec 1, Tab 25 for nickel alloy steels.

8.3 Condition of supply

8.3.1 Forgings are to be normalised, normalised and tempered or quenched and tempered, depending on the grade of steel, as indicated in Sec 1, [5.4.1] or in the approved specification.

8.4 Mechanical tests

8.4.1 At least one set of specimens for mechanical tests (1 tensile and 3 Charpy V-notch specimens) is to be taken from each forging [1.11.2] or batch [1.11.3]; unless otherwise agreed and when possible, specimens are to be cut in the longitudinal direction.

The impact tests are generally to be carried out at the minimum temperature stated for the type of steel; a higher test temperature may be agreed with the Society, however, depending on the design service temperature of the individual applications.

8.5 Non-destructive examination

8.5.1 Unless otherwise required or agreed, class 1 forgings are to be examined by the magnetic particle method.

When the above forgings have thickness higher than 10mm, they are also to be subjected to ultrasonic examination.

9 Stainless steel forgings

9.1 Application

9.1.1 The requirements of this Article apply to stainless steel forgings intended for construction of cargo and storage tanks, pressure vessels, and piping fittings for chemical and/or low temperature applications.

9.1.2 Unless otherwise specified or agreed, the forgings covered by this Article belong to class 1.

9.1.3 Austenitic stainless steels are suitable for use at both elevated and low temperatures where the design temperature is not lower than -165°C.

When austenitic stainless steels are proposed for use at elevated temperatures, details of chemical composition, mechanical properties and heat treatment are to be submitted for consideration and approval.

9.1.4 Stainless steels may also be used for shafts and machinery applications under Article [3].

9.1.5 In the case of applications involving the storage and transport of liquefied gases or fluids at low temperature in general, the appropriate requirements of Pt E, Ch 9, Sec 6 also apply.

9.2 Steel grades and relevant properties

9.2.1 The requirements apply to austenitic Cr-Ni steels.

The general requirements relevant to designation, chemical composition, mechanical properties and condition of supply are specified in Sec 1, [7] relevant to rolled products.

9.2.2 Other types of stainless steels (ferritic-austenitic or martensitic), complying with international or national specifications, may be accepted for particular applications (e.g. [9.1.4]); their relevant specification is to be submitted for approval.

Table 3 : Chemical composition limits for hull steel forgings (1/7/2015)

Steel type	C	Si	Mn	P	S	Cr	Mo	Ni	Cu (3)	Total residuals
C, C - Mn	0,23 (1) (2)	0,45	0,30 1,50	0,035	0,035	0,30 (3)	0,15 (3)	0,40 (3)	0,30	0,85
Alloy	(4)	0,45	(4)	0,035	0,035	(4)	(4)	(4)	0,30	

Note 1: Composition in percentage mass by mass maximum unless shown as a range.
Note 2: Rudder stocks and pintles are to be of weldable quality.
Note 3: At the discretion of the Manufacturer or the request of the Society, suitable grain refining elements such as aluminium, niobium or vanadium may be added. The content of such elements is to be reported.
Note 4: Elements designated as residual elements in the individual specifications are not to be intentionally added to the steel. The content of such elements is to be reported.

(1) The carbon content may be increased above this level provided that the carbon equivalent (Ceq) is not more than 0,41%, calculated using the following formula:

$$Ceq = C + \frac{Mn}{6} + \frac{Cr + Mo + V}{5} + \frac{Ni + Cu}{15} (\%)$$

(2) The carbon content of C and C-Mn steel forgings not intended for welded construction may be 0,65 maximum.
(3) Elements are considered as residual elements.
These elements are not to be intentionally added to the steel and their content is to be reported.
(4) Specification is to be submitted for approval.

9.3 Mechanical tests

9.3.1 (1/4/2009)

Sampling and mechanical tests are to be in compliance with the requirements of [3.6] and [7.7], as appropriate, depending on the application (machinery or pressure systems).

Unless otherwise required, impact tests on the austenitic grades are to be performed for design temperature lower than -105°C and are to be carried out at -196°C.

The results of the tests are to be in accordance with the requirements of Sec 1, [7.6.1].

9.4 Non-destructive examination

9.4.1 Unless otherwise required or agreed, class 1 forgings are to be examined by the liquid penetrant test and/or by the ultrasonic method, as appropriate, depending on the application.

9.5 Corrosion tests

9.5.1 For forgings intended for chemicals, the corrosion tests, ASTM A262 Practice E (copper- copper sulphate sulphuric) or ASTM A262 Practice C (nitric acid test), as appropriate, may be required to be carried out on one piece per batch.

Tests in accordance with other recognised standards may be accepted subject to the agreement of the Society.

Table 4 : Mechanical properties for hull steel forgings (1/7/2015)

Steel type (1)	Tensile strength (2) R _m min. N/mm ²	Yield stress R _e min. N/mm ²	Elongation A ₅ min. %		Reduction of area Z min. %	
			Long.	Tang.	Long.	Tang.
C and C - Mn	400	200	26	19	50	35
	440	220	24	18	50	35
	480	240	22	16	45	30
	520	260	21	15	45	30
	560	280	20	14	40	27
	600	300	18	13	40	27
Alloy	550	350	20	14	50	35
	600	400	18	13	50	35
	650	450	17	12	50	35

(1) For forgings intended for rudder stock and pintles of ships with ICE Class Notation see [2.6.4].
(2) Unless otherwise agreed, the tensile strength is not to exceed the specified value by more than 120 N/mm² for R_m < 600 N/mm² or 150 N/mm² for R_m ≥ 600 N/mm²

Table 5 : Chemical composition limits (1) for machinery steel forgings (1/7/2003)

Steel type	C	Si	Mn	P	S	Cr	Mo	Ni	Cu (2)	Total residuals
C, C - Mn	0,65 (1)	0,45	0,30 1,50	0,035	0,035	0,30 (2)	0,15 (2)	0,40 (2)	0,30	0,85
Alloy (4)	0,45	0,45	0,30 1,00	0,035	0,035	Min 0,40 (5)	Min 0,15 (5)	Min 0,40 (5)	0,30	-

(1) Composition in percentage mass by mass maximum unless shown as a range or as a minimum.
(2) The carbon content of C and C-Mn steel forgings intended for welded construction is to be 0,23 maximum. The carbon content may be increased above this level provided that the carbon equivalent (Ceq) is not more than 0,41%.
(3) Elements are considered as residual elements unless shown as a minimum.
(4) Where alloy steel forgings are intended for welded constructions, the proposed chemical composition is subject to approval by the Classification Society.
(5) One or more of the elements is to comply with the minimum content.

Table 6 : Mechanical properties for machinery steel forgings (1/7/2003)

Steel type	Tensile strength R_m min. N/mm ² (1)	Yield stress R_e min. N/mm ²	Elongation A_5 min. (%)		Reduction of area Z min. (%)		Hardness (Brinell) (3)
			Long.	Tang.	Long.	Tang.	
C and C-Mn	400	200	26	19	50	35	110-150
	440	220	24	18	50	35	125-160
	480	240	22	16	45	30	135-175
	520	260	21	15	45	30	150-185
	560	280	20	14	40	27	160-200
	600	300	18	13	40	27	175-215
	640	320	17	12	40	27	185-230
	680	340	16	12	35	24	200-240
	720	360	15	11	35	24	210-250
Alloy	760	380	14	10	35	24	225-265
	600	360	18	14	50	35	175-215
	700	420	16	12	45	30	205-245
	800	480	14	10	40	27	235-275
	900	630	13	9	40	27	260-320
	1000	700	12	8	35	24	290-365
	1100	770	11	7	35	24	320-385

(1) The following ranges for tensile strength may be additionally specified:
specified minimum tensile strength: < 900 N/mm² ≥ 900 N/mm²
tensile strength range: 150 N/mm² 200 N/mm²
(2) For propeller shafts intended for ships with ice class notation Charpy V-notch impact testing according to [3.6.4] is to be performed.
(3) The hardness values are typical and are given for information purposes only.

Table 7 : Carbon and carbon-manganese steels - Chemical composition

Steel grade	Deoxidation	Chemical composition (%) (1)						
		C max	Mn	Si	P max	S max	Al tot. min. (1)	Ni max
410 HA	killed	0,20	0,60 - 1,40	0,10 - 0,40	0,030	0,030	0,020	0,40
410 HB	killed							
410 HD	killed and fine grained							
460 HA	killed	0,22	0,90 - 1,60	0,10 - 0,50	0,030	0,030	0,020	0,40
460 HB	killed							
460 HD	killed and fine grained	0,20						
510 HA	killed	0,23	1,00 - 1,60	0,10 - 0,50	0,030	0,030	0,020	0,40
510 HB	killed							
510 HD	killed and fine grained	0,20						

(1) Nb, V or Ti may be used for grain refining as a complete or partial substitute for Al, in which case the minimum value for Al content does not apply. The grain refining elements are to be specified at the time of approval; in general Nb and V are not to exceed 0,05% and 0,10%, respectively. Additional alloying elements are to be submitted for consideration and approval. Residual elements not intentionally added are not to exceed the following limits: Cu ≤ 0,30%; Cr ≤ 0,25%; Mo ≤ 0,10%. Total: Ni + Cu + Cr + Mo ≤ 0,80%

Table 8 : Low alloy steels - Chemical composition

Steel grade	Deoxidation (2)	Chemical composition (%) (1)						
		C	Mn	Si	P max	S max	Cr	Mo
0,3Mo	Si killed	0,12 - 0,22	0,40 - 0,90	0,10 - 0,40	0,030	0,030	-	0,25 - 0,35
1Cr 0,5Mo	Si killed	≤ 0,18	0,40 - 1,70	0,10 - 0,40	0,030	0,030	0,80 - 1,15	0,40 - 0,65
2,25Cr 1Mo	Si killed	≤ 0,15	0,10 - 0,40	0,10 - 0,40	0,030	0,030	2,00 - 2,50	0,90 - 1,10

(1) Residual elements are not to exceed the following limits: Cu ≤ 0,30%; Ni ≤ 0,30%.
(2) The aluminum total is to be lower than 0,020% for all grades of steel. The aluminum content is to be mentioned on the ladle analysis certificate.

Table 9 : Carbon and carbon-manganese steels - Mechanical properties

Steel grade	Yield stress R_{eH} (N/mm ²) min. for thickness t (mm)		Tensile strength R_m (N/mm ²)	Elongation A_5 (%) min. for thickness t (mm) (1)				Average impact energy (J) min.				
	t ≤ 100	100 < t ≤ 250		t ≤ 100		100 < t ≤ 250		Test temp (°C)	KVL	KVT		
				L	T	L	T					
410 HA	230	220	410 - 530	24	23	23	21	+ 20	41	27		
410 HB								0			27	22
410 HD								- 20				
460 HA	260	250	460 - 600	23	21	22	20	+ 20	41	27		
460 HB								0			27	22
460 HD								280				
510 HA	280	270	510 - 650	21	20	20	19	+ 20	41	27		
510 HB								0				
510 HD								330			310	- 20

(1) L and T stand for longitudinal and tangential specimens, respectively.

Table 10 : Low alloy steels - Mechanical properties

Steel grade	Yield stress R_{eH} (N/mm ²) min. for thickness t (mm) (1)		Tensile strength R_m (N/mm ²)	Elongation A_5 (%) min. (2)		Average impact energy (J) min.		
	t ≤ 100	100 < t ≤ 250		L	T	Test temp (°C)	KVL	KVT
0,3Mo	285	270	440 - 570	23	21	+20	50	34
1Cr 0,5Mo	270	255	440 - 590	20	18		44	27
2,25Cr 1Mo	275	275	500 - 650	19	17		60	50

(1) For thickness or diameter greater than 250 mm, values are to be agreed with the Society.
(2) L and T stand for longitudinal and tangential specimens, respectively.

Table 11 : Minimum proof stress ($R_{p0,2}$) values at elevated temperatures

Steel grade	Thickness (mm)	$R_{p0,2}$ (N/mm ²) at a temperature (°C) of							
		150	200	250	300	350	400	450	500
410 HA (1)	≤ 100	190	180	170	150	140	135	135	
410 HB (1)	> 100	175	170	160	150	140	135	135	
410 HD (1)	≤ 100	205	190	170	150	140	135	130	
	> 100	190	175	165	150	140	135	130	
460 HA (1)	≤ 100	215	210	195	175	170	160	155	
460 HB (1)	> 100	200	200	190	-	-	-	-	
460 HD (1)	≤ 100	235	215	200	175	165	155	150	
	> 100	220	200	190	175	-	-	-	
510 HB (1)	≤ 100	235	225	210	190	180	175	170	
	> 100	220	210	200	190	-	-	-	
510 HD (1)	≤ 100	255	235	215	190	180	170	165	
	> 100	240	215	205	190	-	-	-	
0,3Mo			200	185	170	160	150	140	130
1Cr 0,5Mo			210	200	180	170	160	150	140
2,25Cr 1Mo			240	230	220	210	200	190	180

(1) The values at $R_{p0,2}$ for temperatures ≤ 250°C are for guidance only.

SECTION 4

STEEL CASTINGS

1 General

1.1 Application

1.1.1 General (1/7/2003)

The requirements of this Section apply to steel castings intended for hull, structural applications, machinery, boilers, pressure vessels and piping systems.

These requirements are applicable only to steel castings where the design and acceptance tests are related to mechanical properties at ambient temperature. For other applications, additional requirements may be necessary, especially when the castings are intended for service at low or elevated temperatures.

This Article specifies the requirements common to all the above-mentioned steel products, while the specific requirements for the various applications are indicated in Articles [2] to [7].

Alternatively, castings which comply with national or proprietary specifications may be accepted provided such specifications give reasonable equivalence to these requirements or are otherwise specially approved or required by the Society.

1.1.2 Mass productions

For mass produced small castings, the Manufacturer may adopt particular procedures for testing and inspection subject to the approval of the Society.

1.1.3 Special requirements

Special requirements may be specified in the case of applications intended for dangerous substances or for particularly severe service conditions.

In the case of applications involving the storage and transport of liquefied gases or fluids at low temperature in general, the appropriate requirements of Pt E, Ch 9, Sec 6 also apply.

1.2 Classification of castings

1.2.1 For the purposes of this Section, castings are divided into two Classes depending on their service:

- a) class 1 castings are those intended for important applications, such as propellers, components of crankshafts, engine bedplates, cylinder and piston heads, rudder stocks, anchors, other important components of hull and machinery, components under pressure relative to class 1 pressure systems, cargo gear items subjected to severe stresses, etc. The castings indicated in [1.1.3] also pertain to class 1.
- b) class 2 castings are all those subject to testing and not included in class 1.

1.3 Manufacture

1.3.1 Manufacturing process

The steel is to be manufactured as detailed in Sec 1, [1.2.1].

1.3.2 Flame and arc-air shaping

All flame cutting, scarfing or arc-air gouging to remove surplus metal is to be undertaken in accordance with recognised good practice and, unless otherwise accepted, is to be carried out before the final heat treatment. Preheating is to be employed when necessitated by the composition and/or thickness of the casting. For certain components, subsequent machining of all flame cut surfaces may be required.

1.3.3 Welding of castings (1/7/2003)

When two or more castings are joined by welding to form a composite component, the proposed welding procedure is to be submitted for approval. Welding procedure qualification tests may be required.

1.4 Approval

1.4.1 (1/7/2003)

Class 1 castings are to be made by a Manufacturer approved by the Society.

When the approval is not required, the Manufacturers are in any event to be recognised on a case-by-case basis.

Provisions for the approval are given in the "Rules for the approval of Manufacturers of materials".

For certain components including steel casting subjected to surface hardening process, the proposed method of manufacture may require special approval by the Society.

1.5 Quality of materials

1.5.1 All castings are to be free from surface or internal defects which would be prejudicial to their proper application in service.

The surface finish is to be in accordance with good practice and with any specific requirements of the approved plans or purchase order.

1.6 Visual and dimensional examination

1.6.1 Visual examination

All castings are to be cleaned and adequately prepared for examination; suitable methods include pickling, caustic cleaning, wire brushing, local grinding, and shot or sand blasting.

The surfaces are not to be hammered or treated in any way which may obscure defects; procedures of this kind may cause rejection of the piece.

All products are to be submitted by the Manufacturer to visual examination; where applicable, this is to include the examination of internal surfaces and bore.

All class 1 castings are also to be presented to the Surveyor for visual examination.

Unless otherwise specified, the visual examination of class 2 castings by the Surveyor is not required.

1.6.2 Verification of dimensions

The verification of dimensions and tolerances is the responsibility of the Manufacturer.

Checks of dimensions for verification of compliance with the approved plans are, in general, required for important castings, to the Surveyor's satisfaction.

1.7 Non-destructive examination

1.7.1 General (1/7/2006)

When required by the applicable Parts of the Rules, the approved plans, the approved procedures for welded composite components or, in specific cases, the Surveyor, appropriate non-destructive tests are to be carried out and the results reported by the Manufacturer.

All such tests are to be carried out by competent operators qualified according to the requirements of Ch 1, Sec 1, [3.6.4], using reliable and efficiently maintained equipment. The testing procedures, the extent of testing and the acceptance criteria are to be in accordance with the applicable Rules and any specific requirements of the approved plans, to the Surveyor's satisfaction.

IACS Recommendation No. 69 is regarded as an example of an acceptable standard.

The Manufacturer is to provide the Surveyor with a report confirming that the required examinations have been carried out without revealing significant defects; details of the procedure used are also to be indicated in the report.

1.7.2 Magnetic and liquid penetrant examination

A magnetic particle or liquid penetrant examination is to be carried out when the castings are in the finished condition.

Where current flow methods are used for magnetisation, particular care is to be taken to avoid damaging finished machined surfaces by contact burns from the prods.

Unless otherwise agreed, these tests are to be carried out in the presence of the Surveyor.

1.7.3 Radiographic examination

Radiographic examination is to be carried out by the Manufacturer at positions as indicated on the approved plans and, at least for class 1 castings, in areas deemed susceptible to casting defects; welded joints and adjacent zones are also to be checked.

All radiographs are to be submitted to the Surveyor for acceptance.

1.7.4 Ultrasonic examination

Ultrasonic examination is to be carried out following the final heat treatment at positions as indicated in [1.7.3].

Unless otherwise required, this examination is to be carried out by the Manufacturer but Surveyors may request to be

present, in particular in order to verify that the examination is carried out in accordance with the agreed procedure.

1.8 Rectification of defects

1.8.1 (1/7/2015)

Where defective steel castings are to be rectified by grinding or other suitable means, with or without subsequent weld repair, the prior approval of the Society is to be obtained.

Procedure of removal of defect and weld repair is to be in accordance with IACS Recommendation No. 69.

1.8.2 Rectification of defects by grinding

Defects and unacceptable imperfections may be removed by machining or chipping. Flame-scarfing or arc-air gouging may also be used provided that preheating is employed when necessary and that the surfaces of the resulting depression are subsequently ground smooth.

Complete elimination of the defective material is to be proved by a magnetic particle or liquid penetrant examination.

At the discretion of the Surveyor, the resulting shallow grooves or depressions may be accepted provided that they will cause no appreciable reduction in the strength of the castings and that they are suitably smoothed and contoured by grinding.

Where the presence of surface defects may reasonably raise doubts as to the internal soundness of a casting, additional examinations may be required, at the discretion of the Surveyor, both on the casting itself and, if necessary, on other castings of the same presentation cast with the same procedure.

1.8.3 Rectification of defects by welding

Proposals to repair a defective casting by welding are to be submitted to the Surveyor for approval before this work is commenced.

Such proposals are to include details of the position and extent of all defects, the repair procedure, the heat treatment, if any, and subsequent inspection procedures.

For the purpose of the acceptance of the proposed repairs, due consideration is to be given to the type, class and service conditions of the casting.

When accepted, welding is to be carried out in accordance with an approved welding procedure, as required; see also [1.8.4].

A report (possibly with a sketch) detailing the above information as to the extent and location of all repairs, welding procedure, post-weld heat treatment, non-destructive examinations, results, etc. is to be prepared by the Manufacturer; this report is to be submitted to the Surveyor and attached to the testing documentation.

1.8.4 Welding procedure (1/7/2003)

In the welding procedure the following features are to be taken into account:

- a) important castings and alloy steel castings are to be given a suitable preliminary heat treatment prior to carrying out weld repairs. A similar heat treatment may

also be required for other types of castings where the repair of a major defect is proposed

- b) the excavations are to be suitably shaped to allow good access for welding and, after final preparation for welding, they are to be re-examined by suitable non-destructive testing methods to ensure that all defective material has been eliminated
- c) all castings in alloy steels, other than austenitic and austenitic-ferritic stainless steels and all crankshaft castings, are to be suitably preheated prior to welding. Castings in carbon or carbon-manganese steel may also be required to be pre-heated depending on their chemical composition and the dimensions and position of the weld repairs
- d) welding is to be done under cover in positions free from draughts and adverse weather conditions by qualified welders with adequate supervision. As far as possible, all the weldings are to be carried out in the down-hand (flat) position
- e) the welding consumables used are to be of an appropriate composition giving a weld deposit with mechanical properties similar and in no way inferior to those of the parent castings. The use of low hydrogen type welding consumables is preferred and may be required. Consideration is to be given to the effect of post-weld heat treatment on the mechanical properties of the weld metal.
Welding procedure tests are to be carried out by the Manufacturer to demonstrate that satisfactory mechanical properties can be obtained after heat treatment as detailed in [2.3.1] and [3.3.1]
- f) after welding has been completed, the castings are to be given either a suitable heat treatment in accordance with the requirements in [1.9], or a stress relieving heat treatment at a temperature not lower than 550°C. The type of heat treatment employed will be dependent on the chemical composition of the casting and the dimensions, position and nature of the repairs
- g) special consideration may be given to the omission of post-weld heat treatment or to the acceptance of a local stress relieving heat treatment where the repaired area is small and machining of the casting has reached an advanced stage
- h) on completion of heat treatment, the weld repairs and adjacent material are to be ground smooth and examined by magnetic particle or liquid penetrant testing. Supplementary ultrasonic or radiographic examination may also be required depending on the dimensions and nature of the original defect. Satisfactory results are to be obtained from all forms of non-destructive testing used.

For the rectification of defects on castings for crankshafts, see also [4.7.2].

1.8.5 (1/7/2003)

The Manufacturer is to maintain full records detailing the extent and location of repairs made to each casting and details of weld procedures and heat treatments applied for repairs. These records are to be available to the Surveyor and copies provided on request.

1.9 Condition of supply - heat treatment

1.9.1 Castings are to be suitably heat treated to refine the grain structure and obtain the required mechanical properties.

Heat treatment is to be carried out in suitable furnaces. See Ch 1, Sec 1, [2.3.1].

If a casting is locally reheated or any straightening operation is performed after the final heat treatment, a subsequent stress relieving heat treatment may be required in order to avoid the possibility of harmful residual stresses.

1.9.2 The heat treatment conditions foreseen are indicated in the Articles relevant to the various castings.

When more than one heat treatment condition is specified, the choice of the supply condition, unless otherwise required, is left to the Manufacturer; the condition of supply is always to be mentioned in the testing documentation.

1.10 Pressure test

1.10.1 Castings subject to internal pressure are to be subjected to a hydraulic pressure test in compliance with the conditions laid down in the applicable parts of the Rules.

The test pressure is to be measured by means of a suitable calibrated pressure gauge.

The test is to be performed on the casting in the finished condition and before the application of any coating which may conceal the effect of the test.

Unless otherwise agreed, the test of class 1 castings is to be carried out in the presence of the Surveyor.

A report confirming the satisfactory results of the pressure tests and indicating the relevant testing conditions is to be issued by the Manufacturer.

1.11 Sampling and testing

1.11.1 General

The requirements relevant to the type and number of tests to be carried out are indicated in the Articles relevant to the various applications.

The test samples are to be sufficient for the required tests and for possible re-test purposes, and are to be taken from castings in the supply condition.

The samples are to have a thickness of not less than 30mm.

1.11.2 Individual testing

In the case of individual testing, the sample is to be integral with each casting [1.11.5].

1.11.3 Batch testing

A batch testing procedure may be adopted in the following cases:

- a) small class 1 castings (generally having mass not exceeding 200 kg) of about the same size, made from one cast and heat treated in the same furnace charge; the total mass of the batch is not to exceed 2,5 t
- b) class 2 castings of the same type of steel, of approximately the same size, having mass not exceeding 1000

kg and subjected to the same heat treatment; the total mass of the batch is not to exceed 4 t.

The test samples may be cut from one or more castings [1.11.5] of the batch or, alternatively, separately cast samples may be used. When cast samples are used, they are to be properly identified and heat treated together with the castings of the batch.

1.11.4 Homogeneity of the batch

Where a batch testing procedure is used, hardness tests may be required, at the discretion of the Surveyor, to check the homogeneity of the batch.

1.11.5 Sampling (1/7/2003)

In the case of individual testing [1.11.2], each casting is to be provided with at least the following test samples:

- a) 1 test sample for castings of plain design, provided the finished mass does not exceed 10 t
- b) 2 test samples for castings of complex design or where the finished mass exceeds 10 t
- c) 2 or more test samples corresponding to the number of casts involved, in the case of large castings made from two or more casts which are not mixed in a ladle prior to pouring.

When more than one test sample is provided for the same casting, the test samples are to be integrally cast at locations as widely separated as possible.

For castings where the method of manufacture has been specially approved by the Society in accordance with [1.4.1], the number and position of test samples are to be agreed with the Classification Society having regard to the method of manufacture employed.

In the case of batch testing [1.11.3], when the castings in the batch are 20 or less one sample is required to be taken from the casting representative of the batch; where the number of pieces in the batch exceeds 20, two samples are required per batch.

The test samples are not to be detached from the casting until the specified heat treatment has been completed and they have been properly identified.

A set of specimens is to be cut from each sample for the execution of one tensile test.

1.11.6 Preparation of test specimens (1/10/2019)

For the preparation of test specimens and relevant testing procedure, reference is to be made to the applicable requirements of Ch 1, Sec 2.

Proportional round test specimens with dimensions as specified above in Ch 1, Sec 2, Fig 3 are usually to be used.

For small size bars and similar products the test specimens may consist of a suitable length of bar or other product tested in the full cross-section.

1.11.7 Tensile and hardness tests (1/7/2003)

The results of the tensile test at ambient temperature are to comply with the requirements of the appropriate Tables, or of the relevant approved specification when steels other than those specified in these Rules are accepted.

The Tables give the minimum requirements corresponding to different strength levels but it is not intended that these

values should necessarily be regarded as specific rule grades.

The strength levels are given in multiples of 40 N/mm²; where intermediate levels are accepted, the properties may be obtained by interpolation.

For the properties at elevated temperatures and their verification, when required, see [5.5.1].

Hardness tests of Brinell type may be required for specific applications or, in general, as verification of the homogeneity, at the discretion of the Surveyors. See [1.11.4].

The results of hardness tests are to be in agreement with the appropriate values of the steel tested.

1.11.8 Re-test procedures (1/7/2003)

Samples for possible re-tests are to be taken as near as practicable to the specimens used for the original tests; however, at the discretion of the Surveyors, they may also be taken from other positions or pieces deemed representative of the casting or batch.

Where the result of a tensile test does not comply with the requirements, two additional tests may be taken. If satisfactory results are obtained from both of these additional tests the casting or batch of castings is acceptable. If one or both retests fail the castings or batch of castings is to be rejected.

The additional tests are to be taken, preferably from the same, but alternatively from another test sample representative of the casting or batch of castings.

Re-test procedures are specified in Ch 1, Sec 1, [3.5].

At the discretion of the Manufacturer, when a casting or batch of castings has failed to meet the test requirements, it may be reheat treated and re-submitted for acceptance tests.

1.12 Identification and marking

1.12.1 The Manufacturer is to adopt a system of identification which will enable all finished castings to be traced to the original cast and their manufacturing.

All castings which have been tested and inspected with satisfactory results are to be marked with the following details:

- a) Manufacturer's name or trade mark
- b) Society's brand
- c) identification mark for the grade of steel
- d) cast number or other marking which will enable the history of the fabrication of the casting to be traced
- e) additional, optional marks such as file number and code of the local inspection office, Surveyor's personal brand
- f) test pressure, where applicable.

Modified arrangements for identification and marking may be agreed in the case of small castings manufactured in large numbers.

1.13 Documentation and certification

1.13.1 (1/7/2003)

The testing documentation indicated in Ch 1, Sec 1, [4.2.1] is to be issued and is to include all the information, as appropriate.

The ladle analysis is to include the content of refining and alloying elements as applicable.

Where applicable, details of heat treatment including temperatures and holding times as well as the reports relevant to the non-destructive examination [1.7.1], weld repair [1.8.3] and pressure test [1.10.1] are to be enclosed with the testing documentation.

2 Casting for hull and other welded structures in general

2.1 Application

2.1.1 The requirements of this Article apply to carbon and carbon-manganese steel castings intended for hull and other welded structures in general, where design and acceptance tests are related to mechanical properties at ambient temperature.

2.1.2 Castings intended for use in the construction of stems, sternframes, rudder and propeller shaft supports belong to class1; unless otherwise specified, on a case-by-case basis, other castings belong to class2.

2.2 Steel grades

2.2.1 (1/7/2003)

The steel grades are identified by the letter G, followed by a number indicating the minimum specified tensile strength R_m (in N/mm²).

2.2.2 Limits on the specified minimum tensile strength and grades to be used for hull structures are given in Part B and/or in the relevant approved plans.

In particular, the use of the grades G480 to G600 may be restricted to specific conditions.

2.3 Condition of supply

2.3.1 (1/7/2003)

Castings are to be supplied in one of the following conditions, as required by the steel specification (see [1.9.2]):

- fully annealed
- normalised
- normalised and tempered
- quenched and tempered.

The tempering temperature is to be not less than 550°C.

2.4 Chemical composition

2.4.1 (1/7/2015)

All castings are to be made from killed steel.

The chemical composition of each heat is to be determined by the manufacturer on a sample taken preferably during the pouring of the heat. When multiple heats are tapped into a common ladle, the ladle analysis is to be applied.

Suitable grain refining elements, such as Al, Nb, V, may be used and the content of such elements is to be reported.

The chemical composition is to be appropriate for the type of steel, dimensions and required mechanical properties of the casting.

The chemical composition on ladle analysis is to comply with the limits given in Tab 1.

When alloy steels are proposed, details of chemical composition, heat treatment, mechanical properties, testing inspections and rectification methods are to be submitted for consideration and approval.

2.5 Mechanical properties

2.5.1 (1/7/2003)

The requirements for yield stress, elongation and reduction of area are to comply with the requirements of Tab 2 appropriate to the specified minimum tensile strength or, where applicable, the requirements of the approved specification.

Castings may be supplied at any specified minimum tensile strength selected within the limits detailed in Tab 2 but subject to any additional requirements of the construction Rules relevant to the specific application.

Where it is proposed to use a steel with a specified minimum tensile strength intermediate to those given, corresponding minimum values for the other properties may be obtained by interpolation.

2.6 Mechanical tests

2.6.1 (1/7/2003)

The number of test samples required in the case of individual [1.11.2] or batch [1.11.3] testing is indicated in [1.11.5].

The test specimens for the tensile test are to be taken from each test sample.

2.7 Non-destructive examination

2.7.1 Castings intended for the construction of sternframes, poop structure, rudders and propeller shaft supports are to be non-destructively tested by ultrasonic and magnetic methods.

Other castings are to be examined by non-destructive test methods as required by the approved plans, by the purchase order or, in specific cases, by the Surveyor.

Table 1 : Chemical composition (1/7/2003)

Steel type	Applications	C (max.)	Si (max.)	Mn	S (max.)	P (max.)	Residual elements (max.)				Total residuals (max.)
							Cu	Cr	Ni	Mo	
C,C-Mn	Castings for non-welded construction	0,40	0,60	0,50 - 1,60	0,040	0,040	0,30	0,30	0,40	0,15	0,80
	Castings for welded construction	0,23	0,60	1,60 max	0,040	0,040	0,30	0,30	0,40	0,15	0,80

Table 2 : Mechanical properties (1/7/2003)

Specified minimum tensile strength (1) (N/mm ²) min.	Yield stress (N/mm ²) min.	Elongation on 5,65 S ₀ ^{0.5} (%) min.	Reduction of area (%) min.
400	200	25	40
440	220	22	30
480	240	20	27
520	260	18	25
560	300	15	20
600	320	13	20

(1) A tensile strength range of 150 N/mm² may additionally be specified.

3 Castings for machinery and equipment

3.1 Application

3.1.1 The requirements of this Article apply to carbon and carbon-manganese steel castings, intended for use in the construction of machinery, equipment and components not specifically dealt with in the other Articles of this Section.

Provisions for castings for copper alloy and steel propellers and for anchors are given in Ch 4, Sec 2, [1] Ch 4, Sec 2, [1] and Ch 4, Sec 1, [1], respectively.

3.1.2 Castings intended for parts of engine bedplates, cylinder and piston heads, turbine casings, components in general of important machinery, rudders and anchors belong to class 1; unless otherwise specified on a case-by-case basis, other castings belong to class 2.

3.2 Steel grades

3.2.1 (1/7/2003)

Grades are identified by the letter G, followed by a number indicating the minimum specified tensile strength R_m (N/mm²).

When alloy steels are proposed, details of chemical composition, heat treatment, mechanical properties, testing inspections and rectification method are to be submitted for consideration and approval.

3.3 Condition of supply

3.3.1 (1/7/2003)

Castings are to be supplied in one of the following conditions, as required by the steel specification (see [1.9.2]):

- fully annealed
- normalised, or
- normalised and tempered at a temperature not lower than 550°C
- quenched and tempered.

The tempering temperature is to be not less than 550°C.

Castings for components such as engine bedplates, turbines and other castings in general, where dimensional stability and freedom from internal stresses are important, are to be subjected to an additional stress relief heat treatment at a temperature not lower than 550°C and then cooled in the furnace to 300°C or lower. When the full annealing or the tempering of the normalised and tempered steels is followed by furnace cooling to 300°C or lower, the stress relief treatment is not required.

3.4 Chemical composition

3.4.1 (1/7/2003)

All castings are to be made from killed steel.

Suitable grain refining elements, such as Al, Nb, V, may be used and the content of such elements is to be reported in the ladle analysis.

The chemical composition is to be appropriate for the type of steel, dimensions and required mechanical properties of the castings.

The chemical composition on ladle analysis is to comply with the limits given in Tab 1.

For castings in alloy steel and in other steels accepted on the basis of their approved specification, the full chemical composition (ladle analysis) is to comply with the applicable specification; the ladle analysis is to include all the alloy elements.

3.5 Mechanical properties

3.5.1 (1/7/2003)

The requirements for yield stress, elongation and reduction of area are to comply with the requirements of Tab 2 appropriate to the specified minimum tensile strength or, where applicable, the requirements of the approved specification.

Castings may be supplied at any specified minimum tensile strength selected within the limits detailed in Tab 2 but sub-

ject to any additional requirements of the construction Rules relevant to the specific application.

Where it is proposed to use a steel with a specified minimum tensile strength intermediate to those given, corresponding minimum values for the other properties may be obtained by interpolation.

3.6 Mechanical tests

3.6.1 (1/7/2003)

The number of test samples required in the case of individual [1.11.2] or batch [1.11.3] testing is indicated in [1.11.5].

The test specimens for the tensile test is to be taken from each test sample.

3.7 Non-destructive examination

3.7.1 Ultrasonic examination is to be carried out on the following items:

- a) piston crowns and cylinder covers
- b) parts of engine bedplates
- c) turbine casings
- d) rudder components.

3.7.2 A magnetic particle examination is to be carried out for the following items:

- a) piston crowns and cylinder covers for engines having a bore size greater than 400 mm
- b) parts of engine bedplates
- c) turbine casings
- d) rudder components.

The parts to be examined and the test procedures are to be agreed with the Surveyor.

Other castings are to be examined by non-destructive test methods as required by the approved plans, by the purchase order or, in specific cases, by the Surveyor.

4 Castings for crankshafts

4.1 Application

4.1.1 The requirements of this Article apply to carbon and carbon-manganese steel castings intended for the construction of semi-built and fully built crankshafts.

Alloy steel castings are subject to approval; the detailed specification is to be preliminarily submitted.

The general requirements, specified in Article [1], are also to be complied with, as appropriate.

4.1.2 Castings intended for crankshafts belong to class1.

4.2 Steel grades

4.2.1 (1/7/2003)

As for the chemical composition and mechanical properties, the requirements of [3.2] apply; in the case of particular steels the relevant specification is to be preliminarily submitted for approval.

In connection with the requirements of Pt C, Ch 1, Sec 2, [4.1], the specified minimum tensile strength R_m :

- for non-alloyed steels is not to be higher than 560 N/mm²
- for alloyed steels is not to be higher than 700 N/mm².

4.3 Manufacture

4.3.1 The method of manufacturing is to be approved and approval tests are required to verify the soundness and the properties at significant locations of the castings.

4.4 Condition of supply

4.4.1 Castings are to be supplied in one of the following conditions, as required by the steel specification (see [1.9.2]):

- fully annealed and cooled in the furnace to 300°C or less
- normalised and tempered to a temperature not lower than 550°C, then cooled in the furnace to 300°C or less.

4.5 Chemical and mechanical properties

4.5.1 For carbon and carbon-manganese steel the chemical composition is to comply with the requirements of Tab 1 or the approved specification, as appropriate.

4.5.2 As regards the mechanical properties, the minimum requirements for carbon and carbon-manganese steels are indicated in Tab 2, For steels complying with an approved specification, in particular for alloyed steels, the relevant requirements of such specification apply.

4.6 Mechanical tests

4.6.1 The number and position of the specimens for mechanical tests are specified at the time of approval of the method of manufacture.

4.7 Non-destructive examinations and rectification of defects

4.7.1 Non-destructive examination

Magnetic particle testing is required on all surfaces of the castings in the finished condition.

Where applicable, this test is also to be performed on all flame-cut surfaces not subsequently machined.

Ultrasonic testing is required for all castings.

The directions and procedures for such examinations as well as the evaluation of the relevant indications, complying with the requirements of the engine Manufacturer, are to be previously approved by the Society.

4.7.2 Rectification of defects

Surface defects are to be removed by grinding or machining.

Proposals to repair by welding accidental defects which cannot be dealt with as above and which have moderate extension and are not situated in critical locations for the service behaviour, are to be submitted for approval to the

Society with any necessary detail. In any case, the conditions provided for in [1.8.3] are to be complied with.

5 Castings for boilers, pressure vessels and systems

5.1 Application

5.1.1 The requirements of this Article apply to steel castings which may be subjected to welding, intended for the construction of boilers, pressure vessels, plants and piping systems in general, operating at temperatures not lower than 0°C.

5.1.2 Castings intended for use in the construction of pressure vessels and piping systems of class 1 as defined in Part C belong to class 1.

5.1.3 Castings intended for vessels and systems operating at temperatures lower than 0°C are to comply with the applicable requirements of Article [6] in the case of applications involving the storage and transport of liquefied gases, also with those specified in Pt E, Ch 9, Sec 6 of the Rules.

5.2 Steel grades

5.2.1 The requirements apply to carbon and carbon-manganese steels and low alloy steels (Mo and Cr-Mo steels).

The C and C-Mn steels are classed into three groups and are identified by the minimum ultimate tensile strength R_m (in N/mm²) 400, 440, 480, followed by the letter P.

Carbon and carbon-manganese steels having a minimum specified tensile strength R_m greater than the above but not exceeding 520 N/mm² may be accepted, at the discretion of the Society, on the basis of their detailed specification.

5.2.2 Low alloy steels are designated according to the chemical composition into the grades 0,3Mo - 1Cr0,5Mo - 2,25Cr1Mo - 0,5Cr0,5Mo0,25V.

The figures mean the nominal percentage content of the main alloying elements.

5.3 Condition of supply

5.3.1 Castings are to be supplied in one of the following conditions, as required by the steel specification (see [1.9.2]):

- fully annealed
- normalised
- normalised and tempered
- quenched and tempered.

The tempering temperature is to be not lower than 550°C.

5.4 Chemical composition and mechanical properties

5.4.1 Chemical composition

For steels in accordance with these Rules, the chemical composition on ladle analysis is to comply with the requirements specified in Tab 3.

In the case of steels accepted as an alternative to the above, the approved specification is applicable.

5.4.2 Mechanical properties

For steels in accordance with these Rules, the mechanical properties are indicated in Tab 4.

In the case of steels accepted as an alternative to the above, the approved specification is applicable.

5.5 Mechanical properties at elevated temperature

5.5.1 The values for the 0,2% proof stress ($R_{p0,2}$), at temperatures of 150°C and higher, are given in Tab 5.

The above values are for design purposes only. Their verification is generally not required at the individual inspection of material.

5.5.2 Where, however, a verification of the properties at elevated temperature (above 200°C) is required, the following procedure applies, unless otherwise agreed:

- a tensile test to verify the yield stress is to be performed at an agreed temperature (in relation to the design temperature) rounded to the nearest multiple of 50°C
- the test is to be carried out on samples properly taken from the castings selected
- the test samples are to be heat treated, as required, together with the casting they represent
- the test procedure is to be in compliance with the relevant requirements of Ch 1, Sec 2, [2.1] and Ch 1, Sec 2, [2.2.5]
- the result of the test is to comply with the $R_{p0,2}$ yield stress value specified at the test temperature concerned.

5.5.3 Where figures higher than those shown in Tab 5 and in accordance with recognised standards are proposed by the steel Manufacturer, their verification is required and procedures similar to those detailed in Sec 1, [4.7.2] are to be followed in agreement with the Society.

5.5.4 The values of the estimated average stress to rupture in 100.000 hours, for design purposes only, are given in Sec 1, Tab 21.

Table 3 : Chemical composition

Steel grade	Chemical composition (%) (1)								
	C	Mn	Si	P max	S max	Cr	Mo	V	Ni max
400 P	≤ 0,23	0,50-1,20	≤ 0,60	0,035	0,035	≤ 0,30	≤ 0,15	-	-
440 P	≤ 0,23	0,50-1,20	≤ 0,60	0,035	0,035	≤ 0,30	≤ 0,15	-	0,40 (1)
480 P	≤ 0,25	0,60-1,60	≤ 0,60	0,035	0,035	≤ 0,30	≤ 0,15	-	0,40 (1)
0,5Mo	0,15-0,23	0,50-1,00	0,30-0,60	0,035	0,035	≤ 0,30	0,40-0,60	-	0,40
1Cr0,5Mo	0,10-0,20	0,50-1,00	0,30-0,60	0,035	0,035	1,00-1,50	0,45-0,65	-	0,40
2,25Cr1Mo	0,13-0,20	0,50-1,00	0,30-0,60	0,035	0,035	2,00-2,50	0,90-1,20	-	0,40
0,5Cr0,5Mo0,25V	0,10-0,18	0,40-0,80	0,30-0,60	0,035	0,035	0,70-1,10	0,40-0,60	0,22-0,30	0,40

(1) With the exception of refining elements, additional alloying elements are to be submitted for consideration and approval. Residual elements are not to exceed the following limits (%):
for C and C-Mn steels: Cu ≤ 0,30 ; total : Ni+Cu+Cr+Mo ≤ 0,80
for alloy steels : Cu ≤ 0,30

Table 4 : Mechanical properties

Steel grade	Yield stress R_{eH} (N/mm ²) min.	Tensile strength (N/mm ²)	Elongation A_5 (%) min.	Reduction of area Z (%) min.	Average impact energy (J) at +20°C
					V- or U-notch
400 P	200	400 - 550	25	40	27
440 P	230	440 - 590	22	38	27
480 P	250	480 - 630	20	30	27
0,5Mo	245	450 - 600	21	35	25
1Cr 0,5Mo	290	480 - 630	18	35	25
2,25Cr 1Mo	280	500 - 650	18	35	25
0,5Cr 0,5Mo 0,25V	310	500 - 650	17	35	16

Table 5 : Minimum proof stress ($R_{p0,2}$) values at elevated temperatures

Steel grade	$R_{p0,2}$ (N/mm ²) at a temperature (°C) of									
	150	200	250	300	350	400	450	500	550	600
400 P 440 P 480 P	210	200	185	160	155	150	135			
0,5Mo	235	225	205	185	175	170	155	145	135	125
1Cr 0,5Mo		200		195		185		160		115
2,25Cr 1Mo	310	305	295	290	280	270	255	240	210	180
0,5Cr 0,5Mo 0,25V		245		300		215		195		145

Note 1: The values at $R_{p0,2}$ for temperatures ≤ 200°C are for guidance only.

5.6 Mechanical tests

5.6.1 The number of test samples required in the case of individual [1.11.2] or batch [1.11.3] testing is indicated in [1.11.5].

The test specimens for 1 tensile and 3 Charpy V- or U-notch

impact tests are to be taken from each test sample. Impact tests may be omitted for class 2 castings.

5.7 Non-destructive examination

5.7.1 The castings are to be examined by means of the non-destructive tests required by the applicable Rules or specified in the approved plans or in the purchase order; checks of soundness may also be required in individual cases at the discretion of the Surveyor.

6 Ferritic steel castings for low temperature service

6.1 Application

6.1.1 The requirements of this Article apply to ferritic steel castings intended for welded structural use as in the construction of structures, vessels, plants and piping systems for low temperature service or when, irrespective of the service conditions, they are required to satisfy specified impact properties at temperatures lower than 0°C.

6.1.2 Unless otherwise agreed, castings covered by this Article belong to class 1.

6.1.3 In the case of applications involving the storage and transport of liquefied gases or fluids at low temperature in general, the appropriate requirements of Pt E, Ch 9, Sec 6 also apply.

6.2 Steel grades

6.2.1 The requirements apply to carbon-manganese and nickel alloy steels specified in [6.2.2] [6.2.3].

Steels different from the above may be considered on the basis of the respective specifications relevant to chemical composition, mechanical properties and heat treatment to be submitted individually for approval.

6.2.2 Carbon-manganese steels are classed into three groups indicated by the minimum ultimate tensile strength R_m : 400, 440 or 480 N/mm².

Each group is further subdivided into three grades: LD, LE and LF, based on the impact test temperature specified at -20°C, -40°C and -60°C, respectively.

6.2.3 Ni alloy steels are designated according to the chemical composition into the grades 2,5Ni and 3,5Ni. The figures mean the Ni nominal percentage content.

6.3 Condition of supply

6.3.1 Castings are to be normalised, normalised and tempered or quenched and tempered; see also [1.9.2]. The tempering temperature is to be not lower than 550°C.

6.4 Chemical composition and mechanical properties

6.4.1 Chemical composition

All castings are to be made from killed and fine grained steel.

The chemical composition on ladle analysis is to comply with the limits indicated in Tab 6.

6.4.2 Mechanical properties

The mechanical properties are specified in Tab 7.

6.5 Mechanical tests

6.5.1 The number of tests samples required in the case of individual [1.11.2] or batch [1.11.3] testing is indicated in [1.11.5].

The test specimens for 1 tensile and 3 Charpy V-notch impact tests are to be taken from each test sample.

The impact tests are generally to be carried out at the temperature stated for the type of steel; a higher test temperature may be agreed with the Society, however, depending on the design service temperature of the individual applications.

6.6 Non-destructive examination

6.6.1 The castings are to be examined by means of the non-destructive tests required by the applicable Rules or specified in the approved plans or in the purchase order; checks of soundness may also be required in individual cases at the discretion of the Surveyor.

7 Stainless steel castings

7.1 Application

7.1.1 The requirements of this Article apply to stainless steel castings intended for construction of cargo tanks, pressure vessels and piping fittings for chemicals and/or low temperature applications.

7.1.2 Unless otherwise agreed, the castings covered by this Article belong to class 1.

Table 6 : Chemical composition

Steel grade	Chemical composition (%) (1)							Others
	C max	Mn	Si	P max	S max	Ni	Al tot	
400 LD-LE-LF	0,23	0,50 - 1,20	0,30 - 0,60	0,035	0,035	≤ 0,80	≥ 0,020	Cr ≤ 0,25 Cu ≤ 0,30 Mo ≤ 0,15
440 LD-LE-LF	0,23	0,60 - 1,30	0,30 - 0,60	0,035	0,035	≤ 0,80	≥ 0,020	
480 LD-LE-LF	0,25	0,60 - 1,30	0,30 - 0,60	0,035	0,035	≤ 0,80	≥ 0,020	
2,5Ni	0,16	0,50 - 0,80	0,30 - 0,60	0,035	0,035	2,00 - 3,00	-	
3,5Ni	0,14	0,50 - 0,80	0,30 - 0,60	0,035	0,035	3,00 - 4,00	-	

(1) With the exception of refining elements, additional alloying elements are to be submitted for consideration and approval.

Table 7 : Mechanical properties

Steel grade	Yield stress R_{eH} (N/mm ²) min.	Tensile strength R_m (N/mm ²)	Elongation A_5 (%) min.	Reduction of area Z (%) min.	Average impact energy (J) min.	
					Test temp (°C)	KV
400 LD	200	400 - 550	25	40	- 20	27
400 LE					- 40	
400 LF					- 60	
440 LD	230	440 - 590	22	35	- 20	27
440 LE					- 40	
440 LF					- 60	
480 LD	250	480 - 630	20	30	- 20	27
480 LE					- 40	
480 LF					- 60	
2,5Ni	275	490 - 640	20	35	- 60	35
3,5 Ni	275	490 - 640	20	35	- 80	35

7.1.3 The service conditions of austenitic stainless steel castings may be at both elevated temperatures and low temperatures.

When the castings are for use at elevated temperatures, the specification of the proposed steel relative to chemical composition, heat treatment and mechanical properties is to be submitted for consideration and approval.

7.1.4 In the case of applications involving the storage and transport of liquefied gases or fluids at low temperature in general, the requirements of Pt E, Ch 9, Sec 6 also apply as appropriate.

7.2 Steel grades and relevant properties

7.2.1 General

The requirements apply to austenitic Cr-Ni steels.

Note 1: The steels are designated according to the corresponding AISI type.

Austenitic Cr-Ni steels are required to comply with the chemical composition and mechanical properties indicated in Tab 8 and Tab 9, or with recognised standards or specifications submitted for acceptance.

Other types of stainless steels (ferritic-austenitic), complying with international or national specifications, may be considered for particular applications; the relevant specification of the proposed steel is to be submitted for acceptance.

7.2.2 Condition of supply

The castings are to be solution heat treated in accordance with recognised standards or approved specifications.

7.2.3 Chemical composition

Refer to Tab 8.

7.2.4 Mechanical properties

Refer to Tab 9.

7.3 Mechanical tests

7.3.1 (1/4/2009)

The number of test samples required in the case of individual [1.11.2] or batch [1.11.3] testing is indicated in [1.11.5].

A specimen for 1 tensile test is to be taken from each test sample; in cases when the following sentence applies, three specimens for CV notch impact testing are also to be taken.

Unless otherwise required, impact tests on the austenitic grades are to be performed for design temperature below -105°C and are to be carried out at -196°C.

7.4 Non-destructive examination

7.4.1 Unless otherwise agreed, class 1 castings are to be examined by the liquid penetrant and/or ultrasonic methods, as required, depending on the application.

7.5 Corrosion tests

7.5.1 For castings intended for chemicals, the corrosion tests, ASTM A262 Practice E (Copper-copper sulphate sulphuric) or ASTM A262 Practice C (Nitric acid test) as appro-

priate, may be required to be carried out on one piece per batch.

Tests in accordance with other recognised standards are accepted subject to the agreement of the Society.

Table 8 : Chemical composition

AISI grade designation	Chemical composition (%)								
	C max	Mn max	Si max	P max	S max	Cr	Ni	Mo	Others
304L	0,030	2,0	1,5	0,040	0,030	17,0 - 21,0	8,0 - 12,0	-	
304	0,080	2,0	1,5	0,040	0,030	17,0 - 21,0	8,0 - 12,0	-	
316L	0,030	2,0	1,5	0,040	0,030	17,0 - 21,0	9,0 - 13,0	2,0 - 3,0	
316	0,080	2,0	1,5	0,040	0,030	17,0 - 21,0	9,0 - 13,0	2,0 - 3,0	
347	0,080	2,0	1,5	0,040	0,030	17,0 - 21,0	9,0 - 13,0	-	$10xC \leq Nb \leq 0,80$

Table 9 : Mechanical properties

AISI grade designation	Yield strength $R_{p1,0}$ (N/mm ²) min.	Tensile strength R_m (N/mm ²) min.	Elong. A_5 (%) min.	Reduction of area Z (%) min.	Average impact energy min. KV at -196°C
304 L	215	430	26	40	41
304	220	480	26	40	41
316L	215	430	26	40	41
316	240	480	26	40	41
347	215	480	22	35	41

SECTION 5 IRON CASTINGS

1 General

1.1 Application

1.1.1 General

The requirements of this Section apply to grey lamellar graphite (GG) and spheroidal graphite (SG) iron castings, to be used for the construction of ship structures, machinery, boilers, pressure vessels and piping systems.

The use of cast iron components and the types of cast iron permitted are either regulated by the Sections of the Rules relevant to the construction of the above-mentioned components, or stipulated in each case.

This Article specifies the requirements common to all the above cast iron products, while the appropriate specific requirements are indicated in Articles [2] and [3].

1.1.2 Mass production

For mass produced small castings, the Manufacturer may adopt modified procedures for testing and inspection subject to the approval of the Society.

1.2 Casting designation

1.2.1 The abbreviated designations identifying the cast iron types for the purpose of the Society's requirements are constituted as follows:

- a) a first symbol depending on the category:
"GG" for grey lamellar graphite
"SG" for spheroidal or nodular graphite
- b) a second symbol representing the value of the minimum tensile strength R_m , in N/mm².

1.3 Manufacture

1.3.1 All castings are to be made at foundries where the Manufacturer has demonstrated, to the satisfaction of the Society, that the necessary manufacturing and testing facilities are available and are supervised by qualified personnel. In some cases, the Society may request the Surveyor to proceed with a preliminary visit of the manufacturer's works and to ask for preliminary tests of approval.

1.3.2 Suitable mechanical methods are to be employed for the removal of surplus material from castings. Thermal cutting processes (flame cutting, arc-air cutting) are not acceptable, except as a preliminary operation prior to mechanical methods.

1.3.3 In connection with [1.1.2] to have an inspection procedure adapted to this kind of manufacture, the Manufacturer is to carry out any tests necessary to prove the quality of the prototype castings, as well as periodical examinations

to verify the continued efficiency of the manufacturing technique. The Surveyor is to be given the opportunity to witness these tests.

1.4 Quality of castings

1.4.1 Castings are to be free from surface or internal defects which would be prejudicial to their proper application in service.

The surface finish is to be in accordance with good practice and any specific requirements of the approved plans or purchase order.

1.5 Visual, dimensional and non-destructive examination

1.5.1 All castings are to be cleaned and adequately prepared for examination. The surfaces are not to be hammered, peened or treated in any way which may obscure defects.

1.5.2 Before acceptance, all castings are to be visually examined including, where applicable, the examination of internal surfaces.

1.5.3 Dimensions, tolerances and their verification are the responsibility of the Manufacturer.

1.5.4 (1/7/2006)

The non-destructive examination of castings is not required, unless otherwise specified for particular applications or on the approved drawings or when there are grounds for suspecting the soundness of the casting.

Where the above-mentioned check is required, operators are to be qualified according to the requirements of Ch 1, Sec 1, [3.6.4], equipment are to be reliable and the examination procedures are to be approved by the Surveyor.

1.5.5 When requested in the relevant parts of the Rules, castings are to be pressure tested.

These tests are to be carried out in the presence of the Surveyor.

1.6 Repair of defects

1.6.1 At the discretion of the Surveyor, small surface blemishes may be removed by grinding.

1.6.2 Subject to the prior approval of the Surveyor, local porosity may be rectified by impregnation with a suitable plastic filler, provided that the extent of the porosity is such that it does not adversely affect the strength of the casting.

1.6.3 Repairs by welding are generally not permitted. However, in certain circumstances and in particular when

the mechanical strength of the casting is not involved, a repair by welding may be considered.

In such case, all details of the proposed repair together with the welding procedure foreseen are to be submitted to the Society for examination and approval before the repair work commences.

1.7 Chemical composition

1.7.1 The chemical composition of the iron used is left to the discretion of the Manufacturer, who is to ensure that it is suitable to obtain the mechanical properties specified for the castings.

1.7.2 When required, the chemical composition of ladle samples is to be reported.

1.8 Condition of supply

1.8.1 Except as required in [1.8.2], castings may be supplied in either the as cast or the heat treated condition.

1.8.2 For certain applications such as elevated temperature service, or where dimensional stability is important, castings may be required to be given a suitable tempering or stress relieving heat treatment. This is to be carried out after any refining heat treatment and before machining.

1.9 Sampling and testing

1.9.1 Test material sufficient for the required tests and possible re-tests is to be provided for each casting or batch of castings.

1.9.2 Where separately cast test samples are used, they are to be cast in moulds made from the same type of material as that used for the castings and are to be taken towards the end of pouring of the castings. The samples are not to be stripped from the moulds until the metal temperature is below 500°C.

1.9.3 Where castings are supplied in the heat treated condition, the test samples are to be heat treated together with the castings which they represent. For cast-on samples, the sample is not to be cut off from the casting until the heat treatment is complete.

1.9.4 All test samples are to be suitably marked to identify them with the castings which they represent.

1.9.5 A batch testing procedure may be adopted for castings with a fettled mass of 1 ton or less. All castings in a batch are to be of similar type and dimensions, and cast from the same ladle of treated metal. One test sample is to be provided for each multiple of 2 tons of fettled castings in each batch.

1.9.6 One test sample is to be provided for each casting or batch of castings.

For large castings where more than one ladle of treated metal is used, additional test samples are to be provided so as to be representative of each ladle used.

1.9.7 Where the results of a tensile or impact test do not comply with the requirements, the re-test procedure indicated in Ch 1, Sec 1, [3.5] may be applied.

1.10 Identification and marking

1.10.1 All castings which have been tested and inspected with satisfactory results are to be marked with the following details:

- a) Manufacturer's name or trade mark
- b) Society's brand
- c) identification mark for material designation, as indicated in [1.2]
- d) cast number or other marking which will enable the history of the fabrication of the casting to be traced
- e) test pressure, where applicable
- f) additional optional marks such as file number and code of the local inspection office, Surveyor's personal brand.

Modified arrangements for identification and marking of small castings manufactured in large numbers may be agreed.

1.11 Documentation and certification

1.11.1 The testing documentation indicated in Ch 1, Sec 1, [4.2.1] is to be issued and is to include all the information, as appropriate.

When required, the chemical analysis of ladle samples is to be reported.

Where applicable, the reports relevant to the non-destructive examination and pressure test are to be enclosed with the testing documentation.

2 Grey iron castings

2.1 Application

2.1.1 The requirements of this Article apply to grey iron castings (GG iron castings).

The general requirements specified in Article [1] are also to be complied with, as appropriate.

2.2 Test material

2.2.1 One test sample is to be provided for each casting or batch of castings and, unless otherwise required, may be either gated to the casting or separately cast.

2.2.2 (1/7/2005)

Separately cast test samples are to be used unless otherwise agreed between the Manufacturer and purchaser and generally are to be in the form of bars 30 mm in diameter and of a suitable length.

They are to be cast from the same ladle as the castings in moulds of the same type of material as the moulds for the castings and are not to be stripped from the moulds until the metal temperature is below 500°C. When two or more test samples are cast simultaneously in a single mould, the bars are to be at least 50 mm apart as shown in Fig 1.

In the case of specific components, test samples of other dimensions may be specially required or agreed.

Figure 1 : Test Sample for grey cast iron

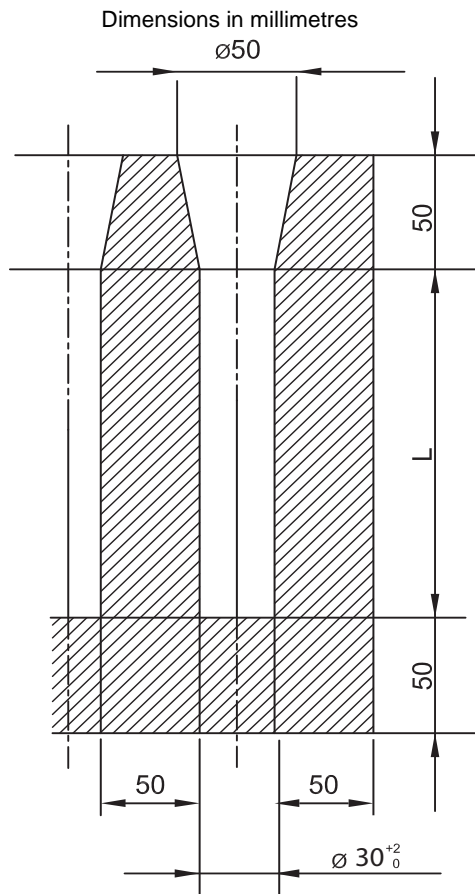

2.2.3 Integrally cast samples may be used when a casting is more than 20 mm thick and its mass exceeds 200 kg, subject to agreement between the Manufacturer and the purchaser. The type and location of the sample are to be selected to provide approximately the same cooling conditions as for the casting it represents.

2.2.4 One tensile test specimen is to be prepared from each test sample. For 30 mm diameter samples, the specimen is to be machined to the dimensions as shown in Ch 1, Sec 2, [2.1.6]. In the case of test samples of other dimensions, the tensile test specimens are to be machined to agreed dimensions.

2.3 Mechanical properties

2.3.1 Only the tensile strength is to be determined and the results obtained from the tests are to comply with the minimum value specified for the castings supplied. The value selected for the specified minimum tensile strength is to be

not lower than 200 N/mm² and not greater than 350 N/mm². In any event it is to be in accordance with any requirements indicated on the approved drawings or in the Rules dealing with the relevant parts.

The fractured surfaces of all tensile test specimens are to be granular, regular and grey in appearance.

2.3.2 Hardness tests may be required in specific cases as a check of homogeneity and are to be performed after the test area has been skinned.

The measured hardness is to be between 160 and 220 Brinell units. Greater hardness may be permissible, however, provided the part remains readily workable.

3 Spheroidal or nodular graphite iron castings

3.1 Application

3.1.1 The requirements of this Article apply to spheroidal or nodular graphite iron castings (SG cast irons) intended for use at ambient temperature.

For other applications, in particular when the castings are intended for service at either low or elevated temperatures, or in the case of severe corrosion, additional requirements and tests may be stipulated.

3.1.2 The general requirements specified in Article [1] are also to be complied with, as appropriate.

3.2 Manufacture and condition of supply

3.2.1 The manufacturing process is to be approved for castings intended for crankshafts.

3.2.2 In addition to the general requirements in [1.8.2], a ferritising heat treatment is to be performed for the special qualities SG 350 and SG 400.

3.3 Test material

3.3.1 The test samples are generally to be one of the standard types detailed in Fig 2, Fig 3 and Fig 4, with a thickness of 25 mm.

However, test samples of other dimensions, as detailed in Fig 2 and Fig 4, may be required in some special cases.

3.3.2 One test sample is to be provided for each casting or batch of castings and, unless otherwise required, may be either gated to the casting or separately cast.

3.3.3 One tensile test specimen is to be prepared from each test sample and machined to the dimensions given in Ch 1, Sec 2.

Figure 2 : Type A test samples (U type)

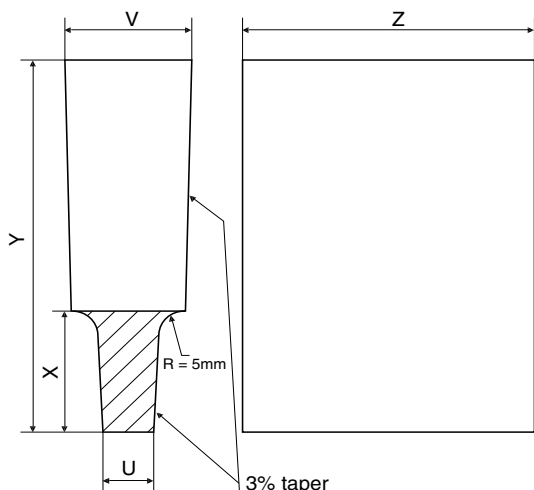

Dimensions:

- u (mm) : 25 (standard sample). 12 or 50 or 75 when specially required
- v (mm) : 55 (standard sample). 40 or 90 or 125 when specially required
- x (mm) : 40 (standard sample). 30 or 60 or 65 when specially required
- y (mm) : 100 (standard sample). 80 or 150 or 165 when specially required
- z : To suit testing machine
- R : Approximately 5 mm.

Figure 3 : Type B test samples (double U type)

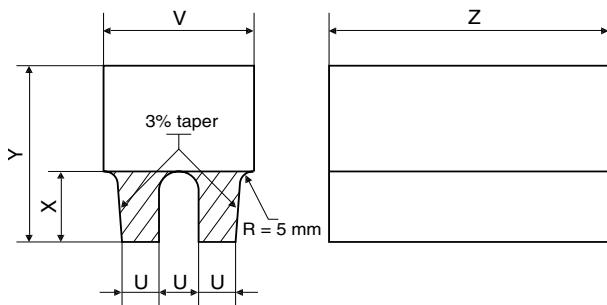

Dimensions:

- u (mm) : 25
- v (mm) : 90
- x (mm) : 40
- y (mm) : 100
- z : To suit testing machine
- R : Approximately 5 mm.

Figure 4 : Type C test samples (Y type)

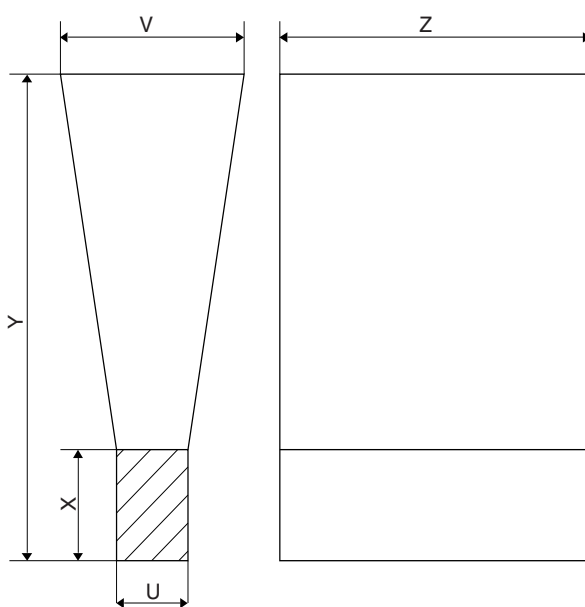

Dimensions:

- u (mm) : 25 (standard sample). 12 or 50 or 75 when specially required
- v (mm) : 55 (standard sample). 40 or 100 or 125 when specially required
- x (mm) : 40 (standard sample). 25 or 50 or 65 when specially required
- y (mm) : 140 (standard sample). 135 or 150 or 175 when specially required
- z,R : To suit testing machine.

3.4 Test and mechanical properties

3.4.1 (1/7/2005)

One tensile test at ambient temperature is to be carried out on each test sample.

If required, a set of three specimens for Charpy V-notch impact tests, is to be prepared from each sample, at ambient temperature.

In particular, the set of impact test specimens is generally to be prepared for castings made in the special qualities SG350S and SG400S spheroidal or nodular.

3.4.2 In the tensile test the ultimate tensile strength and the elongation are to be determined and the results are to comply with the requirements of Tab 1.

Minimum values for the 0,2% yield stress (to be determined only if included in the specification or in the chapter of the Rules related to the concerned part) and typical Brinell hardness values (intended for information only) are also given in Tab 1.

3.5 Metallographic examination

3.5.1 When required for important castings, a representative sample from each ladle of treated metal is to be prepared for metallographic structure examination.

These samples may be taken from the tensile test specimens, or by an alternative procedure agreed with the Surveyor provided they are taken from the ladle they represent towards the end of the casting period.

3.5.2 The metallographic examination is to show that at least 90% of the graphite is in a dispersed or nodular form. Details of typical matrix structures are given in Tab 1 for information purposes only.

3.5.3 The metallographic examination is mandatory for crankshafts.

3.6 Non-destructive examination

3.6.1 In addition to the requirements in [1.5], castings intended for crankshafts are to be submitted to magnetic particle inspection as required at the approval.

Table 1 : Mechanical properties

Qualities	Specified minimum tensile strength R_m (N/mm ²)	Yield strength $R_{p0.2}$ (N/mm ²) min.	Elongation on 5 d (%) (1)	Typical Brinell hardness values	Impact energy		Typical structure of matrix
					Test temp (°C)	KV (J) min (2)	
Ordinary	370	230	17	120 - 180	-	-	Ferrite
	400	250	12	140 - 200	-	-	Ferrite
	500	320	7	170 - 240	-	-	Ferrite/Perlite
	600	370	3	190 - 270	-	-	Ferrite/Perlite
	700	420	2	230 - 300	-	-	Perlite
	800	480	2	250 - 350	-	-	Perlite or Tempered structure
Special	350	220	22 (3)	110 - 170	+20	17 (14)	Ferrite
	400	250	18 (3)	140 - 200	+20	14 (11)	Ferrite

(1) In the case of integrally cast samples, the elongation may be 2 percentage points less.
(2) Average value measured on 3 Charpy V-notch specimens. One result may be below the average value but not lower than the minimum value shown in brackets.
Note 1: For intermediate values of specified minimum tensile strength, the minimum values for 0,2% proof and elongation may be obtained by interpolation.

APPENDIX 1

MEASURES FOR EXTREMELY THICK STEEL PLATES

1 Measures

1.1 General

1.1.1 (1/1/2021)

The thickness and the yield strength shown in Tab 1 apply to the hatch coaming top plating and side plating, and are the controlling parameters for the application of the coun-

termeasures given in Sec 1, [10.7.3]. These controlling parameters are not applicable for the upper deck.

If the as built thickness of the hatch coaming top plating and side plating is below the values contained in Tab 1, countermeasures are not necessary regardless of the thickness and yield strength of the upper deck plating.

Table 1 (1/1/2021)

Yield Strength (N/mm ²)	Thickness (mm)	Option	Measures			
			1	2	3+4	5
355	50 < t ≤ 85	-	N.A.	N.A.	N.A.	N.A.
	85 < t ≤ 100	-	X	N.A.	N.A.	N.A.
390	50 < t ≤ 85	-	X	N.A.	N.A.	N.A.
		A	X	N.A.	X	X
	85 < t ≤ 100	B	X (1)	N.A. (2)	N.A.	X
460 (FCAW - Flux-Cored Arc Welding)	50 < t ≤ 100	A	X	N.A.	X	X
		B	X (1)	N.A. (2)	N.A.	X
460 (EGW - Electro-gas welding)	50 < t ≤ 100	-	X	N.A.	X	X

Measures:

1 NDT other than visual inspection on all target block joints (during construction) according to Sec 1, [10.5].

2 Periodic NDT other than visual inspection on all target block joints (after delivery) according to Sec 1, [10.6]

3 Brittle crack arrest design against straight propagation of brittle crack along weldline to be taken (during construction) according to Sec 1, [10.7.3] b), c) and d).

4 Brittle crack arrest design against deviation of brittle crack from weldline (during construction) according to Sec 1, [10.7.3] a).

5 Brittle crack arrest design against propagation of cracks from other welds (see Note 1 of Sec 1, [10.7.2]) such as fillets and attachment welds, as defined in Sec 1, [10.7.2] b) (during construction) according to Sec 1, [10.7.3] a).

Symbols:

"x" means "To be applied"

"N.A." means "Need not be applied"

"A" and "B": selectable options

Notes:

(1) See Sec 1, [10.7.3] e).

(2) may be required at the discretion of the Society.

APPENDIX 2

ESSO TEST

1 Scope

1.1

1.1.1 (1/1/2014)

The ESSO test method is used to estimate the brittle crack arrest toughness value K_{ca} of rolled steel plates for hull of thickness 100 mm or less.

2 Symbols

2.1

2.1.1 (1/1/2017)

See Tab 1.

Table 1 : Nomenclature (1/1/2017)

Symbol	Unit	Meaning
t_s	mm	Thickness of test specimen
W_s	mm	Width of test specimen
L_s	mm	Length of test specimen
t_r	mm	Thickness of tab plate
W_r	mm	Width of tab plate
L_r	mm	Length of tab plate
L_p	mm	Distance between pins
a	mm	Length of crack projected on surface normal to the line of load
a_a	mm	Maximum crack length at brittle crack arrest position
T	°C	Temperature of test specimen
dT/da	°C / mm	Temperature gradient of test specimen
σ	N/mm ²	Gross stress in tested part (load / $W_s t_s$)
K_{ca}	N/mm ^{3/2}	Brittle crack arrest toughness value

Figure 1 : Conceptual view of test specimen, tab and load jig (1/1/2014)

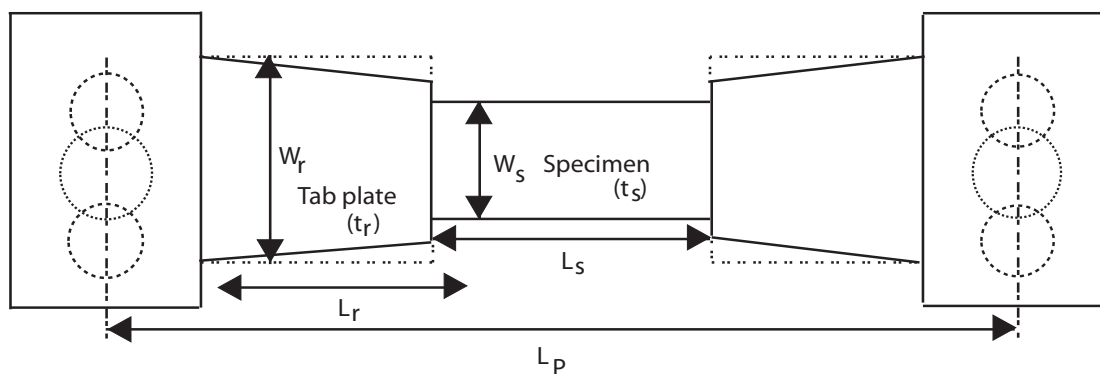

3 Purpose

3.1

3.1.1 (1/1/2014)

The purpose of this test is to encourage the performance of a standard test for assessment of brittle crack arrest toughness with temperature gradient and to obtain the corresponding brittle crack arrest toughness value K_{ca} .

4 Standard test specimen

4.1

4.1.1 (1/1/2014)

Fig 2 shows the shape and size of the standard test specimen.

Figure 2 : Shape and size of specimen (1/1/2014)

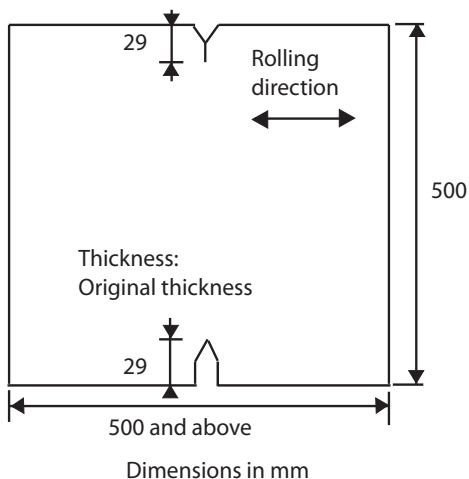

4.1.2 (1/1/2014)

The thickness and width of the test specimen are to be in accordance with Tab 2.

Table 2 : Thickness and width of test specimen (1/1/2014)

Thickness, t_s	100 mm and below
Width of test specimen, W_s	500 mm
Note 1: If the width of the test specimen cannot be made at 500 mm, it may be taken as 600 mm.	

4.1.3 (1/1/2014)

The test specimens are to be taken from the same steel plate.

4.1.4 (1/1/2014)

Test specimens are to be taken in such a way that the axial direction of the load is parallel to the rolling direction of the steel plate.

4.1.5 (1/1/2014)

The thickness of the test specimen is to be the same as the thickness of the steel plate to be used in the vessel structure.

5 Test equipment

5.1

5.1.1 (1/1/2014)

The test equipment to be used is to consist of pin load type hydraulic test equipment capable of tensile tests.

5.1.2 (1/1/2014)

The distance between the pins is to be not less than 2000 mm. The distance between pins refers to the distance between the centres of the pin diameters.

5.1.3 (1/1/2014)

Drop weight type or air gun type impact equipment may be used for the impact energy required to generate brittle cracks.

5.1.4 (1/1/2014)

The wedge is to have an angle greater than the upper notch of the test specimen, and an opening force is to be applied on the notch.

6 Test preparations

6.1

6.1.1 (1/1/2014)

The test piece is to be fixed directly to the pin load jig or by means of weld joint through the tab plate. The overall length of the test specimen and tab plate is to be not less than $3W_s$. The thickness and width of the tab plate are to be in accordance with Tab 3.

Table 3 : Allowable dimensions of tab plate (1/1/2014)

	Thickness: t_r	Width: W_r
Dimensions of tab plate	$0,8t_s \leq t_r \leq 1,5 t_s$ (1) (2)	$W_s \leq W_r \leq 2W_s$
(1) t_s : Thickness of test specimen (2) If the tab plate has a smaller thickness than the test specimen, the reflection of stress wave will be on the safer side for the assessment; therefore, considering the actual circumstances for conducting the test, the lower limit of thickness is taken as $0,8 t_s$.		

6.1.2 (1/1/2014)

Thermocouples are to be fitted at 50 mm pitch on the notch extension line of the test specimen.

6.1.3 (1/1/2014)

If the brittle crack is estimated to deviate from its presumed course, thermocouples are to be fitted at two points separated by 100 mm on the line of load from the notch extension line at the centre of width of the test specimen.

6.1.4 (1/1/2014)

If dynamic measurements are necessary, strain gauges and crack gauges are to be fitted at specific locations.

6.1.5 (1/1/2014)

The test specimen is to be fixed to the testing machine together with the tab plate after welding and the pin load jig.

6.1.6 (1/1/2014)

The impact equipment is to be mounted. The construction of the impact equipment is to be such that the impact energy is correctly transmitted. An appropriate jig is to be arranged to minimize the effect of bending load due to the impact equipment.

7 Test method**7.1****7.1.1 (1/1/2014)**

To eliminate the effect of residual stress or correct the angular deformation of tab welding, a preload less than the test load may be applied before cooling.

7.1.2 (1/1/2014)

Cooling and heating may be implemented from one side, on the side opposite the side on which the thermocouple is fitted, or from both sides.

7.1.3 (1/1/2014)

The temperature gradient is to be controlled in the range of 0,25°C/mm to 0,35°C/mm, in the range of width from 0,3W_s to 0,7W_s at the central part of the test specimen.

7.1.4 (1/1/2014)

When the specific temperature gradient is reached, the temperature is to be maintained for more than 10 minutes, after which the specified test load may then be applied.

7.1.5 (1/1/2014)

After maintaining the test load for at least 30 seconds, a brittle crack is to be generated by impact. The standard impact energy is taken as 20 to 60 J per 1 mm plate thickness. If the brittle crack initiation characteristics of the base metal are high, and it is difficult to generate a brittle crack, the impact energy may be increased to the upper limit of 120 J per 1 mm plate thickness.

7.1.6 (1/1/2014)

Loading is stopped when the initiation, propagation and arrest of crack have been confirmed. Normal temperature is restored, and if necessary, the ligament is broken by gas cutting and the specimen is forcibly broken by using the testing machine. Or, after the ductile crack has been propagated to an adequate length with the testing machine, the ligament is broken by gas cutting.

7.1.7 (1/1/2014)

After forcing the fracture, photos of the fractured surface and the propagation route are to be taken, and the crack length is to be measured.

8 Test results**8.1****8.1.1 (1/1/2014)**

The distance from the top of the test specimen including the notch to the maximum length in the plate thickness direc-

tion of the arrested crack tip is to be measured. If the crack surface deviates from the surface normal to the line of load of the test specimen, the projected length on the surface normal to the line of load is to be measured. In this case, if the trace of brittle crack arrest is clearly visible on the fractured surface, the first crack arrest position is taken as the arrest crack position.

8.1.2 (1/1/2014)

From the results of thermocouple measurement, the temperature distribution curve is to be plotted, and the arrest crack temperature is to be measured corresponding to the arrest crack length.

8.1.3 (1/1/2014)

The brittle crack arrest toughness value (K_{ca} value) of each test is to be determined by using the following formula:

$$K_{ca} = \sigma \sqrt{\pi a} \sqrt{\left(\frac{2W_s}{\pi a}\right) \tan(\pi a / 2W_s)}$$

9 Report**9.1****9.1.1 (1/1/2014)**

The following items are to be reported:

- Testing machine specifications; testing machine capacity, distance between pins (L_p)
- Load jig dimensions; tab plate thickness (t_r), tab plate width (W_r), test specimen length including tab plate (L_s + 2L_r)
- Test specimen dimensions; plate thickness (t_s); test specimen width (W_s) and length(L_s)
- Test conditions; preload stress, test stress, temperature distribution (figure or table) impact energy
- Test results; crack arrest length (a_a), temperature gradient at arrest position, brittle crack arrest toughness (K_{ca})
- Dynamic measurement results (if measurement is carried out); crack growth rate, strain change
- Test specimen photos; fracture route, fractured surface.

9.1.2 (1/1/2014)

If the conditions below are not satisfied, the test results are to be treated as reference values.

- The brittle crack arrest position is to be in the range of the hatched part shown in Fig 3. In this case, if the brittle crack arrest position is more than 50 mm away from the centre of the test specimen in the longitudinal direction of the test specimen, the temperature of the thermocouple at the ±100 mm position is to be within ±3°C of the thermocouple at the centre.
- The brittle crack should not have a distinct crack bifurcation while it propagates.

Figure 3 : Necessary conditions of arrest crack position (1/1/2014)

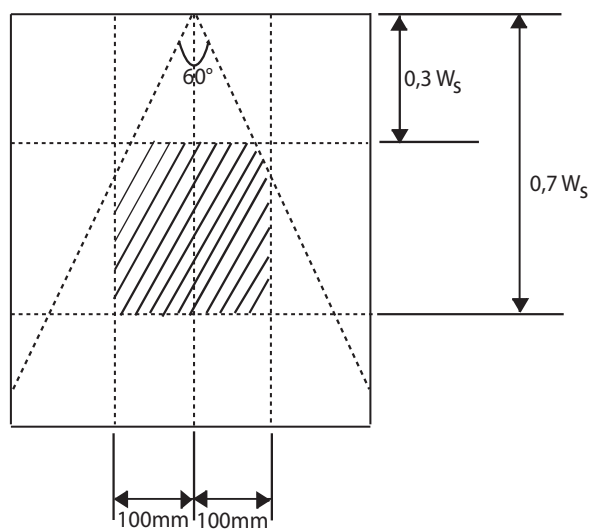

9.1.3 (1/1/2014)

From effective test results measured at more than 3 points, the linear approximation equation is to be determined on the Arrhenius plot, and K_{ca} at the desired temperature is to be calculated. In this case, data should exist on both sides, that is, the high temperature and low temperature sides around the assessed temperature.

APPENDIX 3

ADDITIONAL APPROVAL PROCEDURE FOR CORROSION RESISTANT STEEL

1 Scope

1.1

1.1.1 (1/1/2014)

Approval is to be carried out in accordance with the requirements of Sec 1 together with the additional requirements for corrosion testing specified in this Appendix.

1.1.2 (1/1/2014)

The corrosion tests and assessment criteria are to be in accordance with the Appendix of the Annex to Performance Standard for Alternative Means of Corrosion Protection for Cargo Oil Tanks of Crude Oil Tankers (IMO MSC.289 (87)).

2 Application for approval

2.1

2.1.1 (1/1/2014)

The manufacturer is to submit to the Society a request for approval, which is to include the following:

- a) Corrosion test plan and details of equipment and test environments.
- b) Technical data related to product assessment criteria to confirm corrosion resistance.
- c) The technical background explaining how the variation in added and controlled elements improves corrosion resistance.
- d) The grades, the brand name and maximum thickness of corrosion resistant steel to be approved. Designations for corrosion resistant steels are given in Tab 1.
- e) The welding processes and the brand name of the welding consumables to be used for approval.

3 Approval of test plan

3.1 General

3.1.1 (1/1/2014)

The test program submitted by the manufacturer is to be reviewed by the Society, if found satisfactory, it will be approved and returned to the manufacturer for acceptance prior to tests being carried out. Tests that need to be witnessed by the Surveyor will be identified.

3.2 Method for selection of test samples

3.2.1 (1/1/2014)

Method for selection of test samples is to satisfy the following:

- a) The numbers of test samples is to be in accordance with the requirements of the Appendix of the Annex to Performance Standard for Alternative Means of Corrosion Protection for Cargo Oil Tanks of Crude Oil Tankers (IMO MSC.289 (87)).
- b) The number of casts and test samples selected are to be sufficient to make it possible to confirm the validity of interaction effects and/or the control range (upper limit, lower limit) of the elements which are added or intentionally controlled, to improve corrosion resistance. Where agreed, this may be supported with data submitted by the manufacturer.
- c) Additional tests may be required by the Society when reviewing the test program against item b).

3.3

3.3.1 (1/1/2014)

In addition to [3.2], the Society may require additional tests in the following cases:

- a) When the Society determines that the control range is set by the theoretical analysis of each element based on existing data, the number of corrosion resistance tests conducted in accordance with the Appendix of the Annex to Performance Standard for Alternative Means of Corrosion Protection for Cargo Oil Tanks (IMO MSC.289 (87)) is too few to adequately confirm the validity of the control range of chemical composition;
- b) When the Society determines that the data of the corrosion resistance test result obtained to set the control range of chemical composition varies too widely;
- c) When the Society determines that the validity of the corrosion resistance test result to set the control range of chemical composition is insufficient, or has some flaws;
- d) When the Society's surveyor has not attended the corrosion resistance tests to set the control range of chemical composition, and the Society determines that additional testing is necessary in order to confirm the validity of the test result data; and
- e) When the Society determines that it is necessary, for reasons other than cases a) to d) above.

Note 1: The chemical composition of the corrosion resistant steel is to be within the range specified for rolled steel for hull. Elements to be added to improve the corrosion resistance and for which content is not specified are to be generally within 1% in total.

Table 1 : Designations for Corrosion Resistant Steels (1/1/2014)

Type of steel	Location where steel is effective	Corrosion Resistant Designation
Rolled steel for hull	For strength deck, ullage space	RCU
	For inner bottom	RCB
	For both strength deck and inner bottom plating	RCW

4 Carrying out the approval test

4.1

4.1.1 (1/1/2014)

The manufacturer is to carry out the approval test in accordance with the approved test plan.

5 Attendance of the Society's Surveyor for the tests

5.1

5.1.1 (1/1/2014)

The Society's Surveyor is to be present, as a rule, when the test samples for the approval test are being identified and for approval tests, see also [3.1].

6 Test results

6.1

6.1.1 (1/1/2014)

After completion of the approval test, the manufacturer is to produce the report of the approval test and submit it to the Society.

6.1.2 (1/1/2014)

The Society will give approval for corrosion resistant steel where approval tests are considered by the society to have given satisfactory results based on the data submitted in accordance with the provisions of this App 3.

6.1.3 (1/1/2014)

The certificate is to contain the manufacturer's name, the period of validity of the certificate, the grades and thickness of the steel approved, welding methods and welding consumables approved.

7 Assessment criteria for the results of corrosion resistance tests of welded joints

7.1

7.1.1 (1/1/2014)

The results will be assessed by the Society in accordance with the acceptance criteria specified in the Appendix of the Annex to Performance Standard for Alternative Means of Corrosion Protection for Cargo Oil Tanks (IMO MSC.289 (87)).

APPENDIX 4

TEST METHOD FOR BRITTLE CRACK ARREST TOUGHNESS, K_{CA}

1 General

1.1 Application

1.1.1 (1/1/2021)

Setting a temperature gradient in the width direction of a test specimen, and applying uniform stress to the test specimen, strike the test specimen to initiate a brittle crack from the mechanical notch at the side of the test specimen and causes crack arrest (temperature gradient type arrest testing). Using the stress intensity factor, calculate the brittle crack arrest toughness, K_{ca} , from the applied stress and the arrest crack length. This value is the brittle crack arrest toughness at the temperature of the point of crack arrest (arrest temperature). To obtain K_{ca} at a specific temperature followed by the necessary evaluation, the method specified in Annex A in [8] of this Appendix can be used. As a method for initiating a brittle crack, a secondary loading mechanism can also be used (see Annex B in [9] of this Appendix).

1.2 Scope

1.2.1 (1/1/2021)

This Appendix specifies the test method for brittle crack arrest toughness (i.e. K_{ca}) of steel using fracture mechanics parameter. This Appendix is applicable to hull structural steels with the thickness over 50 mm and not greater than 100 mm specified in Sec 1, [2] or Sec 1, [11].

1.3 Symbols and their significance

1.3.1 (1/1/2021)

The symbols and their significance used in this Appendix are shown in Tab 1.

2 Testing equipment

2.1 General

2.1.1 (1/1/2021)

The following specifies the testing machine needed for conducting the brittle crack arrest test. Testing machine is used

to apply tensile force to an integrated specimen, and impact equipment is used to generate a brittle crack on the test specimen.

2.2 Testing machine

2.2.1 Loading method (1/1/2021)

Tensile load to an integrated specimen is to be hydraulically applied.

The loading method to an integrated specimen using the testing machine is to be of a pin type. The stress distribution in the plate width direction is to be made uniform by aligning the centres of the loading pins of both sides and the neutral axis of the integrated specimen.

2.2.2 Loading directions (1/1/2021)

The loading directions are to be either vertical or horizontal. In the case of the horizontal direction, test specimen surfaces are to be placed either perpendicular to the ground.

2.2.3 Distance between the loading pins (1/1/2021)

The distance between the loading pins is to be approximately $3,4W$ or more, where W is the width of the test specimen. Since the distance between the loading pins sometimes has an effect on the load drop associated with crack propagation, the validity of the test results is determined by the judgment method described in [6.1].

2.3 Impact equipment

2.3.1 Impact methods (1/1/2021)

Methods to apply an impact load to an integrated specimen are to be of a drop weight type or of an air gun type.

The wedge is to be hard enough to prevent significant plastic deformation caused by the impact. The wedge thickness is to be equal to or greater than that of the test specimen, and the wedge angle is to be greater than that of the notch formed in the test specimen and have a shape capable of opening up the notch of the test specimen.

Table 1 : Symbols and their significance (1/1/2021)

Symbol	Unit	Significance
a	mm	Crack length or arrest crack length
E	N/mm ²	Modulus of longitudinal elasticity
E _i	J	Impact energy
E _s	J	Strain energy stored in a test specimen
E _t	J	Total strain energy stored in tab plates and pin chucks
F	MN	Applied load
K	N/mm ^{3/2}	Stress intensity factor
K _{ca}	N/mm ^{3/2}	Arrest toughness
L	mm	Test specimen length
L _p	mm	Distance between the loading pins
L _{pc}	mm	Pin chuck length
L _{tb}	mm	Tab plate length
T	°C	Temperature or arrest temperature
t	mm	Test specimen thickness
t _{tb}	mm	Tab plate thickness
t _{pc}	mm	Pin chuck thickness
W	mm	Test specimen width
W _{tb}	mm	Tab plate width
W _{pc}	mm	Pin chuck width
x _a	mm	Coordinate of a main crack tip in the width direction
x _{br}	mm	Coordinate of the longest branch crack tip in the width direction
y _a	mm	Coordinate of a main crack tip in the stress loading direction
y _{br}	mm	Coordinate of the longest branch crack tip in the stress loading direction
σ	N/mm ²	Applied stress
σ _{Y0}	N/mm ²	Yield stress at room temperature

3 Test specimens

3.1 Test specimen shapes

3.1.1 (1/1/2021)

The standard test specimen shape is shown in Fig 1. Tab 2 shows the ranges of test specimen thicknesses, widths and width-to-thickness ratios. The test specimen length is to be, in principle, equal to or greater than its width.

Figure 1 : Standard test specimen shape (1/1/2021)

Table 2 : Dimensions of test specimens (1/1/2021)

Test specimen thickness, t	$50 \text{ mm} \leq t \leq 100 \text{ mm}$
Test specimen width, W	$350 \text{ mm} \leq W \leq 1000 \text{ mm}$ (Standard width: $W = 500 \text{ mm}$)
Test specimen width/test specimen thickness, W/t	$W/t \geq 5$

3.2 Shapes of tab plates and pin chucks**3.2.1 (1/1/2021)**

The definitions of the dimensions of the tab plates and pin chucks are shown in Fig 2. Typical examples are shown in Fig 3 and Fig 4.

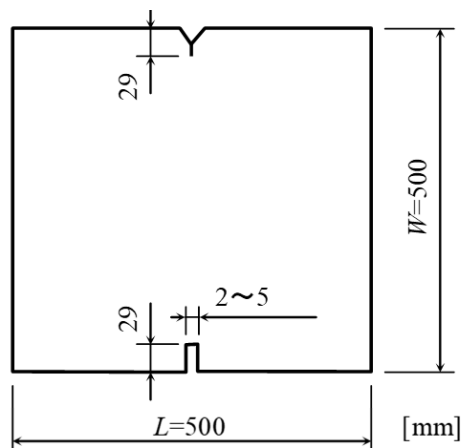
Figure 2 : Definitions of dimensions of tab plates and pin chucks (1/1/2021)

Figure 3 : Examples of the shapes of tab plates and pin chucks (1/1/2021)



(a) Example 1

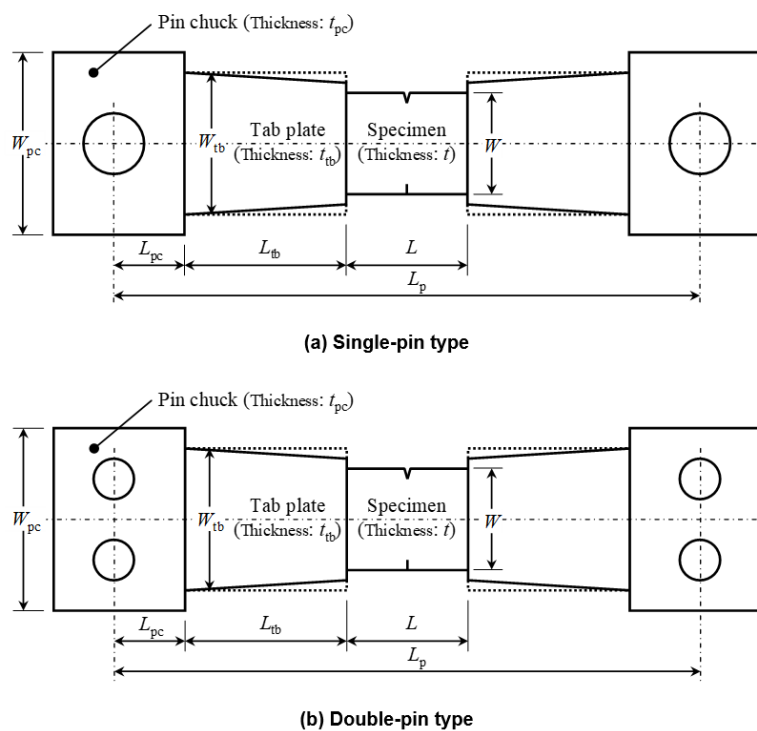
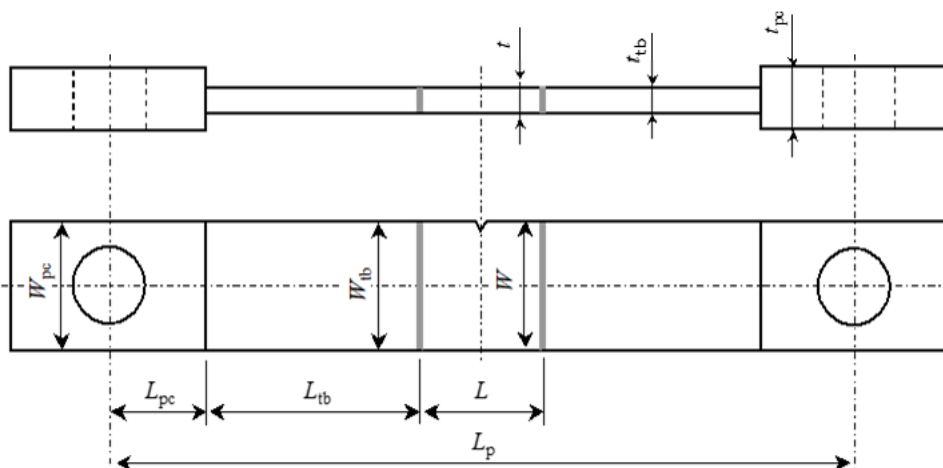
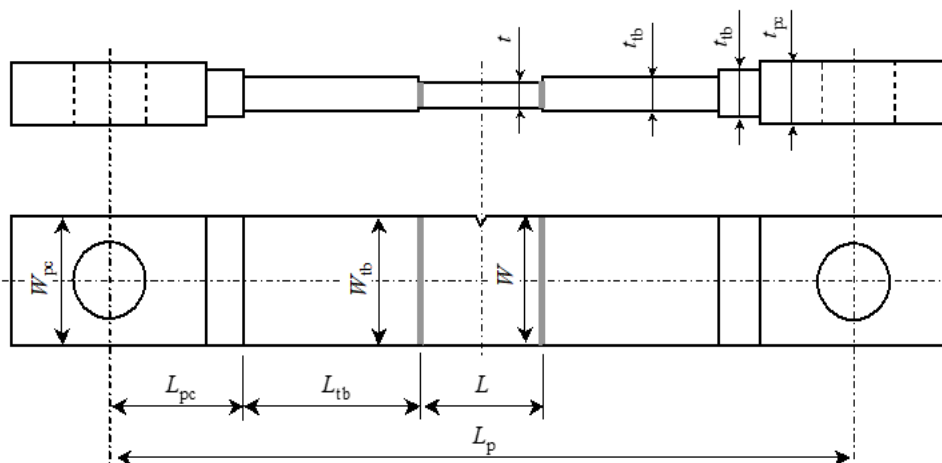

(b) Example 2

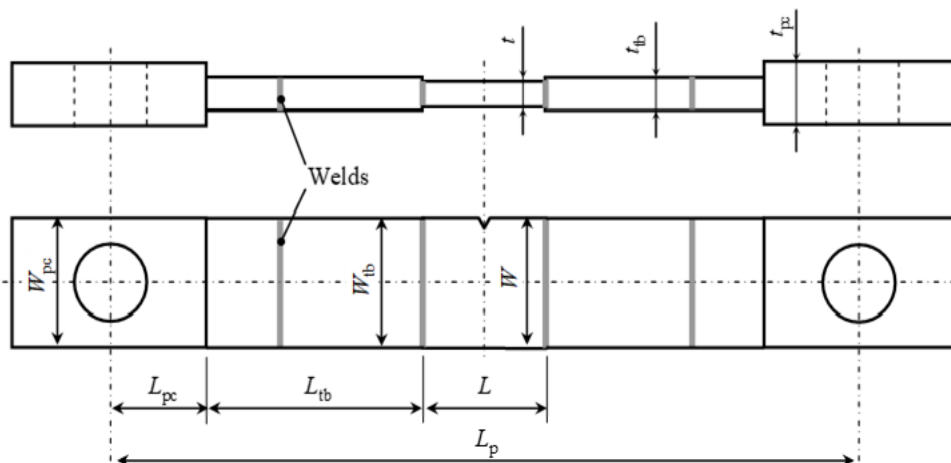

(c) Example 3

Figure 4 : Examples of the shapes of tab plates and pin chucks (1/1/2021)

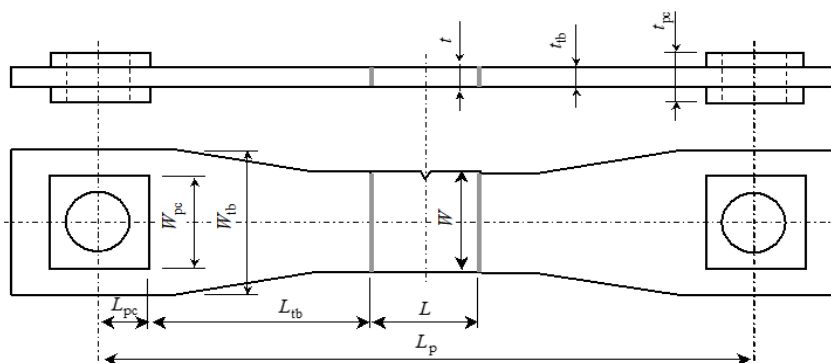

(d) Example 4

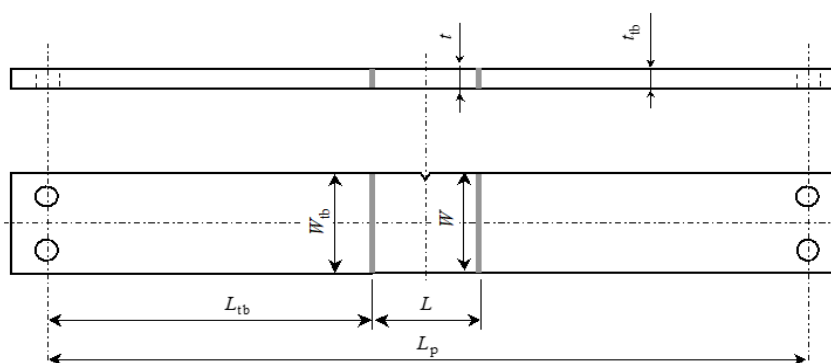

(e) Example 5

3.2.2 Tab plates (1/1/2021)

The tolerances of tab plate dimensions are shown in Tab 3. When the lengths of the tab plates attached to both ends of a test specimen are different, the shorter length is to be used as the tab length, L_{tb} .

Table 3 : Tolerances of tab plate dimensions (1/1/2021)

Tab plate thickness, t_{tb}	$0,8t \leq t_{tb} \leq 1,5t$
Tab plate width, W_{tb}	$W \leq W_{tb} \leq 2W$
Total length of a test specimen and tab plates, $L + 2L_{tb}$ (Total length of a test specimen and a single tab plate $L + L_{tb}$)	$L + 2L_{tb} \geq 3,0W$ $(L + L_{tb} \geq 2,0W)$
Tab plate length (L_t)/Tab plate width, (W)	$L_{tb}/W \geq 1,0$

3.2.3 Pin chucks (1/1/2021)

The pin chuck width, W_{pc} , is to be in principle equal to or more than the tab plate width, W_{tb} .

The pin chucks are to be designed to have a sufficient load bearing strength. When pin chucks attached to both ends of an integrated specimen are asymmetric, the length of the shorter one is to be used as the pin chuck length, L_{pc} .

The distance between the pins, L_p , is obtained from the equation (1). In the case as shown in Fig 4 (e), example 5, L_p is obtained by setting $L_{pc} = 0$.

$$L_p = L + 2L_{tb} + 2L_{pc} \quad (1)$$

3.3 Welding of test specimen and tab plates

3.3.1 (1/1/2021)

Test specimen, tab plates, and pin chucks are to be connected by welding. The welds are to have a sufficient force bearing strength.

As shown in Fig 5 (a), the flatness (angular distortion, linear misalignment) of the weld between a test specimen and a tab plate is to be 4 mm or less per 1 m. In the case of preloading, however, it is acceptable if the value after preloading satisfies this condition. As shown in Fig 5 (b), the accuracy of the in-plane loading axis is to be 0,5% or less of the distance between the pins, and the accuracy of the out-of-plane loading axis is to be 0,4% or less of the distance between the pins.

Figure 5 : Dimensional accuracy of weld between test specimen and tab plate (1/1/2021)

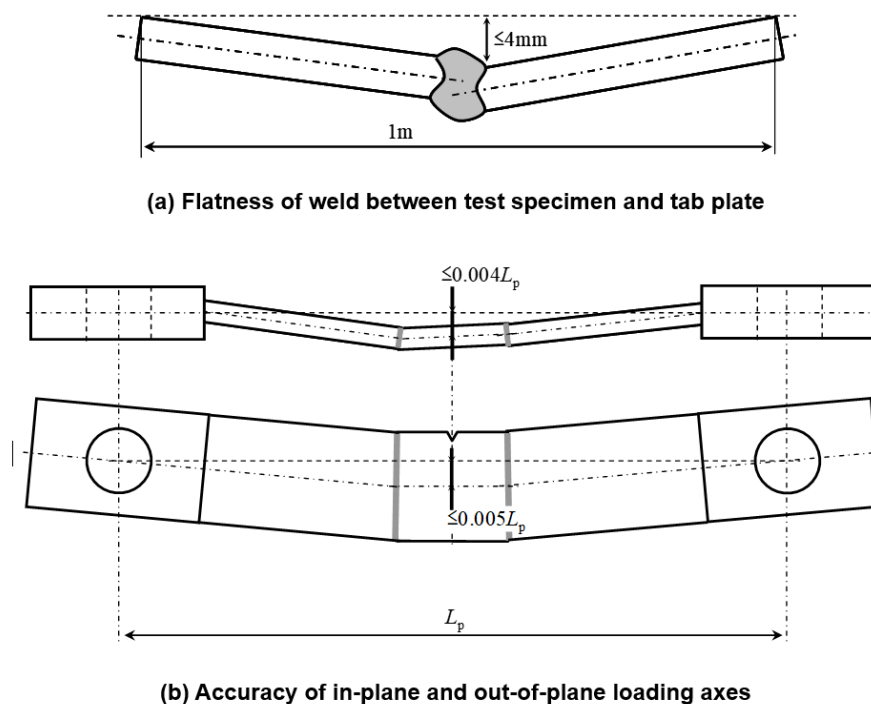

4 Test methods

4.1 General

4.1.1 (1/1/2021)

The following specifies methods for conducting the arrest toughness test.

4.2 Temperature control methods

4.2.1 (1/1/2021)

A predetermined temperature gradient is to be established across a test specimen width by soldering at least nine thermocouples to the test specimen for temperature measurement and control.

Temperature gradient is to be established in accordance with the following conditions:

- a) A temperature gradient of 0,25 - 0,35 °C/mm is to be established in a test specimen width range of 0,3W - 0,7W. When measuring the temperatures at the centre position of the test specimen thickness, it is to be kept within ± 2 °C for 10 minutes or more, whereas when measuring the temperatures on the front and back surface positions of the test specimen, it is to be kept within ± 2 °C for $(10+0,1t)$ [mm] minutes or more taking account of the time needed for soaking to the centre. If the temperature gradient at 0,3W - 0,7W is less than 0,25 °C/mm, crack arrest may become difficult, and if

the gradient is larger than 0,35 °C/mm, the obtained arrest toughness may be too conservative

- b) At the test specimen width centre position (i.e., 0,5W), and in the range of ± 100 mm in the test specimen length direction, the deviation from the temperature at the centre position in the length direction is to be controlled within ± 5 °C. However, when temperature measurement is not performed at the centre position in the length direction, the average temperature at the closest position is to be used as the temperature at the centre position in the length direction
- c) At the same position in the width direction, the deviation of the temperature on the front and back surfaces is to be controlled within ± 5 °C.

4.3 Crack initiation methods

4.3.1 (1/1/2021)

Impact energy is to be applied to a test specimen to initiate a crack. However, if the energy is excessive, it may influence on the test results. In that case, the results are to be treated as invalid data in accordance with the judgment criteria specified in [6.2]. It is desirable to use equation (2) and Fig 6 as guides for obtaining valid data.

$$E_i / t \leq \min(1,2\sigma - 40,200) \quad (2)$$

Where the variables have the following units: E_i [J], t [mm], and σ [N/mm²], and min means the minimum of the two values.

Figure 6 : Recommended range of impact energy (1/1/2021)

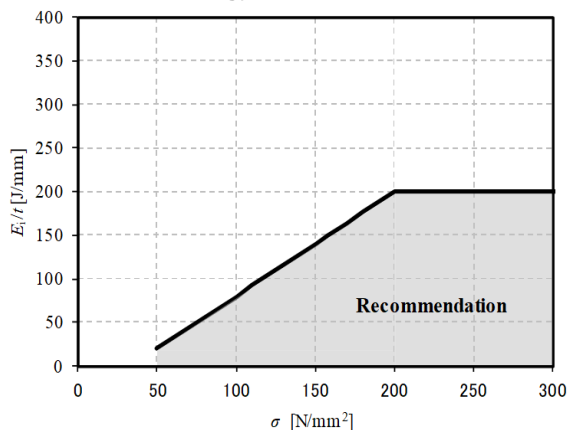

5 Test procedures

5.1 General

5.1.1 (1/1/2021)

The following specifies the procedures for testing brittle crack arrest toughness.

5.2 Pretest procedures

5.2.1 (1/1/2021)

- Install an integrated specimen in the testing machine
- Mount a cooling device on the test specimen. A heating device may also be mounted on the test specimen
- Install an impact apparatus specified in [2.3], on the testing machine. Place an appropriate reaction force receiver as necessary

Note 1: The above procedures (1) through (3) do not necessarily specify the order of implementation, and they may be completed, for example, on the day before the test

- After checking that all measured values of the thermocouples indicate room temperature, start cooling. The temperature distribution and the holding time is to be as provided in the specifications in [4.2]
- Set an impact apparatus, as specified in [2.3] so that it can supply predetermined energy to the test specimen
- Apply force to the test specimen until it reaches the predetermined value. This force is applied after temperature control to prevent autonomous crack initiation during force increase. Alternatively, temperature control may be implemented after loading. The loading rate and applied stress are to satisfy the conditions (a) and (b) described below, respectively:

1) Loading rate

There is no specification of loading rate, but it is to be determined considering that an excessively slow loading rate may prolong the temperature control period, thereby allowing the temperature distribution to depart from the desired condition and an excessively fast loading rate may cause over-shooting of the load

2) Applied stress/yield stress ratio

Applied stress is to be within the range shown by equation:

$$\sigma \leq (2/3) \cdot \sigma_{Y0} \quad (3)$$

As a guide, a value equal to 1/6 of σ_{Y0} or more is desirable. If applied stress is larger than that specified by equation (3), the test may give a non-conservative result

- To initiate a crack, the notch may be cooled further immediately before impact on the condition that the cooling does not disturb the temperature in the range of 0,3W - 0,7W. The test temperature in this case is to be the measured temperature obtained from the temperature record immediately before the further notch cooling
- Record the force value measured by a force recorder.

5.3 Loading procedures

5.3.1 (1/1/2021)

- After holding a predetermined force for 30 seconds or more, apply an impact to the wedge using the impact apparatus. If a crack initiates autonomously and the exact force value at the time of the crack initiation cannot be obtained, the test is invalid
- After the impact, record the force value measured by the force recorder
- When the force after the impact is smaller than the test force, consider that crack initiation has occurred

Note 1: An increase in the number of times of impact may cause a change in the shape of the notch of the test specimen. Since the number of impact has no effect on the value of brittle crack arrest toughness, no limit is specified for the number of impact. However, because the temperature gradient is often distorted by impact, the test is to be conducted again, beginning from temperature control when applying repeated impact to the wedge.

- When crack initiation, propagation, and arrest are observed, remove the force.

5.4 Procedures after testing

5.4.1 (1/1/2021)

- Remove the impact apparatus
- Remove the cooling device, thermocouples, and strain gauges
- Return the temperature of the test specimen to room temperature. For that purpose, the test specimen may be heat-tinted using a gas burner or the like. If it is necessary to prevent heating of the fracture surface, this method is to be avoided
- After gas-cutting an uncracked ligament, use the testing machine to cause ductile fracture, as necessary. Alternatively, it is also possible to gas-cut the uncracked ligament after using the testing machine to develop a ductile crack to a sufficient length.

5.5 Observation of fracture surfaces

5.5.1 (1/1/2021)

- Photograph the fracture surfaces and propagation path
- Measure the longest length of the arrest crack tip in the plate thickness direction, and record the result as the arrest crack length. The arrest crack length is to include the notch length. In the case where a crack deviates from the direction vertical to the loading direction, the length projected to the plane vertical to the loading line is defined as the arrest crack length. In the following cases, however, judge the results according to the methods described for each case:

1) Crack re-initiation

In the case where a brittle crack has re-initiated from an arrested crack, the original arrest position is defined as the arrest crack position. Here re-initiation is defined as the case where a crack and re-initiated cracks are completely separated by a stretched zone and brittle crack initiation from the stretched zone can be clearly observed. In the case where a crack continuously propagates partially in the thickness direction, the position of the longest brittle crack is defined as the arrest position

2) Crack branching

In the case where a crack deviates from the direction vertical to the loading direction, the length projected to the plane vertical to the loading line is defined as the arrest crack length. Similarly, in the case of crack branching, the length of the longest branch crack projected to the plane vertical to the loading line is defined as the branch crack length. More specifically, from the coordinates (x_a, y_a) of the arrest crack tip position and the coordinates (x_{br}, y_{br}) of the branch crack tip position shown in Fig 7, obtain the angle θ from the x-axis and define x_a as the arrest crack length, a . Here, x is the coordinate in the test specimen width direction, and the side face of the impact side is set as $x = 0$; y is the coordinate in the test specimen length direction, and the notch position is set as $y = 0$

- Prepare a temperature distribution curve (line diagram showing the relation between the temperature and the distance from the test specimen top side) from the thermocouple measurement results, and obtain the arrest temperature T corresponding to the arrest crack length.

Figure 7 : Measurement methods of main crack and branch crack lengths (1/1/2021)

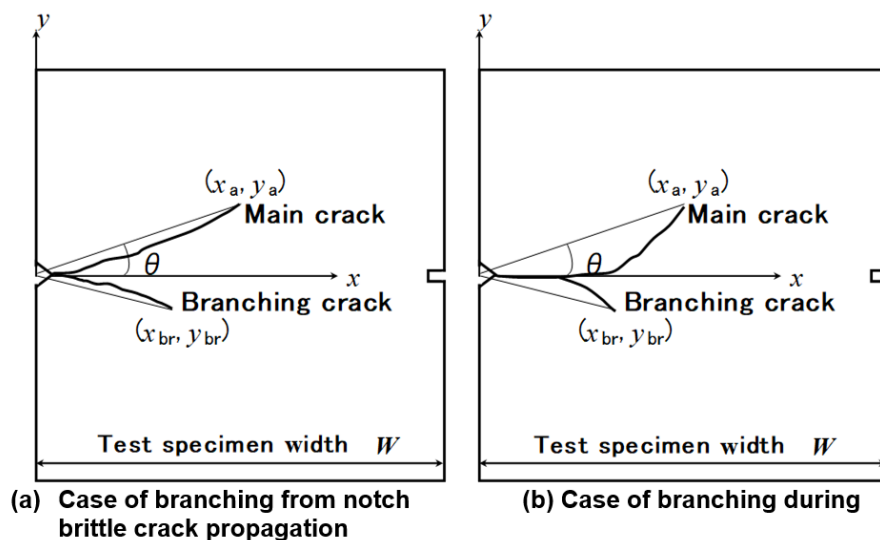

6 Determination of arrest toughness

6.1 Judgment of arrested crack

6.1.1 (1/1/2021)

When an arrested crack satisfies all of the conditions (a) through (d) below as shown in Fig 8, the length of the

arrested crack determined by [5.5] is valid. If any of the conditions is not met, the arrest toughness calculated from [6.3] is invalid

Figure 8 : Necessary conditions of arrest crack position (1/1/2021)

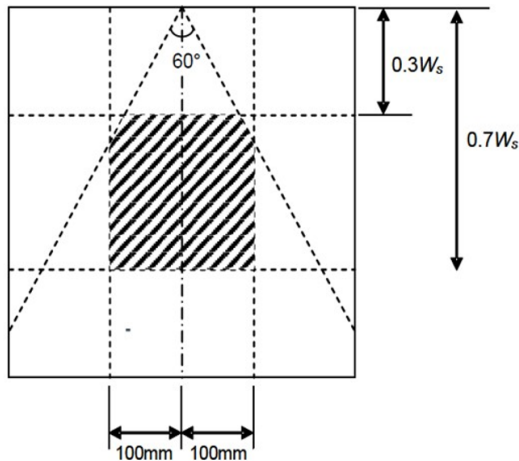

a) Conditions for crack propagation path:

All of the crack path from crack initiation to arrest is to be within the range shown in Fig 9. However, in the case where a main crack tip lies within this range but a part of the main crack passes outside the range, the arrest toughness may be assessed as valid if the temperature at the most deviated position of the main crack in the y direction is lower than that at $y = 0$, and also K for the main crack falls within $\pm 5\%$ of K for a straight crack of the same a . The calculation method of K_s for the main crack and a straight crack is obtained from equation (4).

$$K = K_I \cdot \cos\left(\frac{\Phi}{2}\right)^3 + 3 \cdot K_{II} \cdot \cos\left(\frac{\Phi}{2}\right)^2 \cdot \sin\left(\frac{\Phi}{2}\right) \quad (4)$$

b) Conditions for arrest crack length:

$$0,3 \leq (a/W) \leq 0,7 \quad (5)$$

$$(a/t) \geq 0,7 \quad (6)$$

$$(a/L_p) \leq 0,15 \quad (7)$$

Note 1: Equation (7) ensures minimal influence of force drop at the centre of the specimen which might be caused by crack propagation and reflection of the stress wave at the two ends of the specimen. However, application of equation (7) is not necessarily required if the strain and the crack length have been dynamically measured and the value of the strain at the time of arrest is 90% or more of the static strain immediately before crack initiation.

c) Conditions for crack straightness:

$$|y_a| \leq 50 \text{ mm} \quad (8)$$

In the case where $50 \text{ mm} < |y_a| \leq 100 \text{ mm}$ and $|\theta| \leq 30^\circ$, the result is valid only when the temperature at $x = 0,5W$ and $y = \pm 100 \text{ mm}$ falls within $\pm 2,5 \text{ C}$ of that at $x = 0,5W$ and $y = 0$.

d) Conditions for crack branching:

$$(x_{br}/x_a) \leq 0,6 \quad (9)$$

Figure 9 : Allowable range of main crack propagation path (1/1/2021)

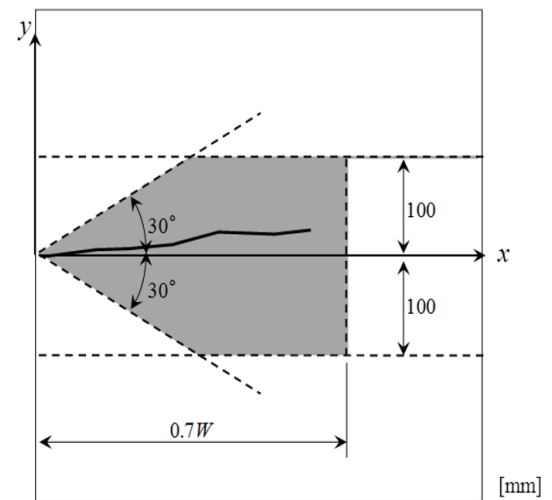

6.2 Assessment of impact energy

6.2.1 Impact energy is to satisfy equation (10). If it does not satisfy the equation, the value of arrest toughness calculated from the equations in [6.3] is invalid.

Conditions for impact energy:

$$\frac{E_i}{E_s + E_t} \leq \frac{5a - 1050 + 1,4W}{0,7W - 150} \quad \text{where } 0,3 \leq \left(\frac{a}{W}\right) \leq 0,7 \quad (10)$$

where the variables have the following units: a [mm], and W [mm]. E_i is impact energy calculated from the equation (11). E_s and E_t are calculated from equations (12) and (13), respectively.

Note 1: If equation (10) is not satisfied, the influence of impact energy on the stress intensity factor is too large to obtain an accurate arrest toughness.

Note 2: In the case where the tab plates are multistage as shown in Fig 3 (b), calculate and total the strain energy of each tab plate using equation (12).

Note 3: In the case where tab plate widths are tapered as shown in Fig 4 (d), calculate the strain energy based on elastostatics.

$$E_i = mgh \quad (11)$$

$$E_s = \frac{10^9 \cdot F^2}{2 \cdot E} \cdot \frac{L}{Wt} \quad (12)$$

$$\dot{\epsilon}_t = \frac{10^9 \cdot F^2}{E} \cdot \left(\frac{L_{tb}}{W_{tb} t_{tb}} + \frac{L_{pc}}{W_{pc} t_{pc}} \right) \quad (13)$$

where the variables have the following units: E_s [J], E_t [J], F [MN], E [N/mm²], L [mm], W [mm], and t [mm].

6.3 Calculation of arrest toughness

6.3.1 (1/1/2021)

The arrest toughness, K_{ca} , at the temperature, T , is to be calculated from equation (14) using the arrest crack length, a , and the applied stress, s , judged by [6.1]. Calculate s from equation (15).

$$K_{ca} = \sigma \cdot \sqrt{\pi a} \cdot \left[\frac{2W}{\pi a} \cdot \tan\left(\frac{\pi a}{2W}\right) \right]^{\frac{1}{2}} \quad (14)$$

$$\sigma = \frac{10^6 \cdot F}{W \cdot t} \quad (15)$$

where the variables have the following units: F [MN], W [mm], and t [mm].

If the conditions specified in [6.1] and [6.2] are not satisfied, the K_{ca} calculated from equation (14) is invalid.

7 Reporting

7.1 General

7.1.1 (1/1/2021)

Using Tab 4, the following items are to be reported:

- a) Test material: Steel type and yield stress at room temperature
- b) Testing machine: Capacity of the testing machine
- c) Test specimen dimensions: Thickness, width, length, angular distortion, and linear misalignment
- d) Integrated specimen dimensions: Tab plate thickness, tab plate width, integrated specimen length including the tab plates, and distance between the loading pins
- e) Test conditions: Applied force, applied stress, temperature gradient, impact energy, and the ratio of impact

energy to the strain energy stored in the integrated specimen (sum of test specimen strain energy and tab plate strain energy)

- f) Test results:
 - 1) Judgment of arrest: Crack length, presence or absence of crack branching, main crack angle, presence or absence of crack re-initiation, and arrest temperature
 - 2) Arrest toughness value
- g) Temperature distribution at moment of impact: Thermocouple position, temperature value, and temperature distribution
- h) Test specimen photographs: Crack propagation path (one side), and brittle crack fracture surface (both sides)
- i) Dynamic measurement results: History of crack propagation velocity, and strain change at pin chucks.

Note 1: Item (9) is to be reported as necessary.

Table 4 : Report sheet for brittle crack arrest test results (1/1/2021)

Item	Details		Symbol	Condi- tions/ Results	Unit	Valid/ Invalid
(1) Test material	Steel type		-		-	-
	Yield stress at room temperature		σ_{Y0}		N/mm ²	-
(2) Test equipment	Testing machine capacity		-		MN	-
(3) Test specimen dimensions	Thickness		t		mm	
	Width		W		mm	
	Length		L		mm	
	Angular distortion + linear misalignment		-		mm/m	
(4) Integrated spec- imen dimensions	Tab plate thickness		t_{tb}		mm	
	Tab plate width		W_{tb}		mm	
	Test specimen length including a tab plate		$L + L_{tb}$		mm	
	Distance between loading pins		L_p		mm	
(5) Test conditions	Applied force		F		MN	
	Applied stress		σ		N/mm ²	
	Temperature gradient		-		°C/mm	
	Impact energy		E_i		J	
	Ratio of impact energy to strain energy stored in integrated specimen		$E_i / (E_s + E_t)$		-	
(6) Test results	Judgment of crack propagation/arrest	Crack length	a		mm	
		Presence/absence of crack branching	-		-	-
		Ratio of branch crack length to main crack	x_{br}/x_a		-	
		Main crack angle	θ		degree (°)	
		Presence/absence of crack re-initiation	-		-	
		Temperature at crack arrest position	T		°C	
	Arrest toughness value		K_{ca}		N/mm ^{3/2}	
(7) Temperature distribution at moment of impact	Temperature measurement position		-	Attached	-	-
	Temperature at each temperature measure- ment position		-	Attached	°C	-
	Temperature distribution curve		-	Attached	-	
(8) Test specimen photographs	Crack propagation path		-	Attached	-	
	Brittle crack fracture surface (both sides)		-	Attached	-	
(9) Dynamic meas- urement results	History of crack propagation velocity		-	Attached	-	
	Strain change at pin chucks		-	Attached	-	

8 ANNEX A: Method for obtaining K_{ca} at a specific temperature and the evaluation

8.1 General

8.1.1 (1/1/2021)

This Article specifies the method for conducting multiple tests specified in this Appendix to obtain K_{ca} value at a specific temperature T_D .

8.2 Method

8.2.1 (1/1/2021)

A number of experimental data show dependency of K_{ca} on arrest temperature, as expressed by equation 16, where T_K [K] (= T [°C]+273), c and K_0 are constants.

$$K_{ca} = K_0 \cdot \exp\left(\frac{c}{T_K}\right) \quad (16)$$

The arrest toughness at a required temperature T_D [K] can be obtained by following the procedures below:

- Obtain at least four valid K_{ca} data
- Approximating $\log K_{ca}$ by a linear expression of $1/T_K$, determine the coefficients $\log K_0$ and c for the data described in item a) by using the least square method

$$\log K_{ca} = \log K_0 + c \cdot \frac{1}{T_K} \quad (17)$$

- Obtain the value of $(K_{ca}/K_0)\exp(c/T_K)$ for each data item. When the number of data outside the range of 0,85 through 1,15 does not exceed, the least square method used in item b) is considered valid. Here is an integer obtained by rounding down the value of (number of all data divided by 6). If this condition is not met, conduct additional tests to add at least two data and apply the procedure in item b) to the data
- The value of $K_0 \exp(c/T_D)$ is defined as the estimated value of K_{ca} at T_D . The estimated value for the temperature corresponding to a specific value of K_{ca} can be obtained from $T_K = c/\log(K_{ca}/K_0)$. If the condition specified in item c) is not met, these estimated values are treated as reference values.

8.3 Evaluation

8.3.1 (1/1/2021)

The straight-line approximation of arrhenius plot for valid K_{ca} data by interpolation method are to comply with either the following:

- The evaluation temperature of K_{ca} (i.e. - 10 degree C) is located between the upper and lower limits of the arrest temperature, with the K_{ca} corresponding to the evaluation temperature not lower than the required K_{ca} (e.g. 6,000 N/mm^{3/2} or 8,000 N/mm^{3/2}), as shown in Fig. 10
- The temperature corresponding to the required K_{ca} (e.g. 6,000 N/mm^{3/2} or 8,000 N/mm^{3/2}) is located between

the upper and lower limits of the arrest temperature, with the temperature corresponding to the required K_{ca} not higher than the evaluation temperature (i.e. -10 degree C), as shown in Fig 11.

Figure 10 : Example for evaluation of K_{ca} at - 10 degree C (1/1/2021)

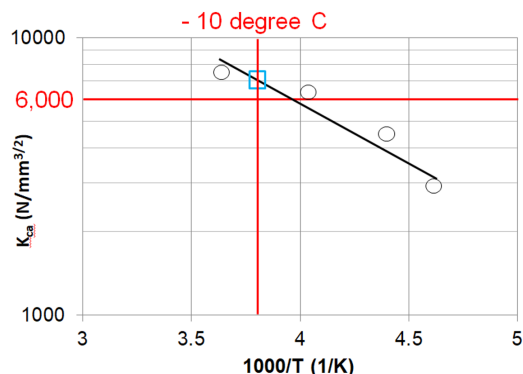
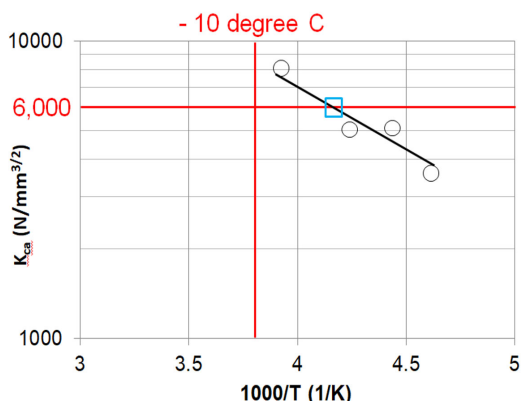

Figure 11 : Example for evaluation of temperature corresponding to the required K_{ca} (1/1/2021)



If both of a) and b) above are not satisfied, conduct additional tests to satisfy this condition.

9 ANNEX B: Double tension type arrest test

9.1 Features of this test method

9.1.1 (1/1/2021)

A double tension type arrest test specimen consists of a main plate and a secondary loading tab. The main plate is a test plate for evaluating brittle crack arrest toughness. The secondary loading tab is a crack starter plate for assisting a brittle crack to run into the main plate. After applying a pre-determined tension force and a temperature gradient to the main plate, a secondary force is applied to the secondary loading tab by a secondary loading device to cause a brittle crack to initiate and run into the main plate. The arrest toughness is evaluated from the arrest temperature and the crack length in the main plate.

The narrow connection part of the main plate and the secondary loading tab in this test suppress the flow of the tension stresses of the secondary loading tab into the main

plate. The values of arrest toughness obtained by this method can be considered the same as the results obtained by the brittle crack arrest toughness test specified in this Appendix.

The specifications described in this Appendix are to be applied to conditions not mentioned in this Article.

9.2 Test specimen shapes

9.2.1 (1/1/2021)

The recommended shapes of the entire double tension type arrest test specimen and the secondary loading tab are shown in Fig 12 and Fig 13, respectively. The requirements in [3.2] apply to the shapes of the tab plates and pin chucks

Note 1: Because of the narrowness of the connection part, slight crack deviation may lead to failure of the crack to enter the main plate. The optimum shape design of the secondary loading tab depends on the type of steel and testing conditions.

Figure 12 : Example of shape of entire test specimen (1/1/2021)

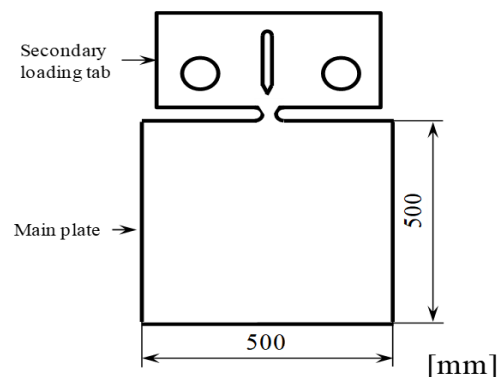
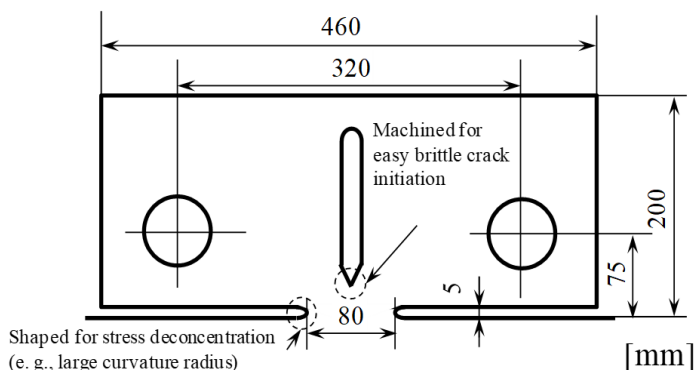

Figure 13 : Example of shape of secondary loading tab (1/1/2021)



9.3 Temperature conditions and temperature control methods

9.3.1 (1/1/2021)

Establish a temperature gradient in the main plate in order to evaluate its brittle crack arrest toughness. The specifications for temperature gradients and methods for establishing the temperature gradient are described in [4]. In addition, in the double tension type arrest test, the secondary loading tab must be cooled. The secondary loading tab is cooled without affecting the temperature gradient of the main plate. As in the cooling method for test specimens described in this Appendix, cooling may be applied using a cooling box and a coolant. The temperature of the secondary loading tab can be measured using thermocouples as described in this Appendix.

9.4 Secondary loading method

9.4.1 (1/1/2021)

A secondary loading device is used to apply force to the secondary loading tab. The secondary loading device is to satisfy the conditions below:

- **Holding methods of secondary loading device**

To avoid applying unnecessary force to the integrated specimen, the secondary loading device must be held in an appropriate way. Suspension type or floor type holding methods can be used. In the suspension type method, the secondary loading device is suspended and held by using a crane or a similar device. In the floor type method, the secondary loading device is lifted and held by using a frame or a similar device

- **Loading system**

A hydraulic type loading system is most suitable for applying a force to the secondary loading tab. However, other methods may be used. The requirements in [3.2] apply to the shapes of the tab plates and pin chucks

- **Loading method**

The method of loading the secondary loading tab is to be a pin type loading method. A loading method other than a pin type may be used by agreement among the parties concerned. The loading rate is not specifically specified because it does not have a direct influence on the crack arrest behavior of the main plate.

APPENDIX 5

OUTLINE OF REQUIREMENTS FOR UNDERTAKING ISOTHERMAL CRACK ARREST TEMPERATURE (CAT) TEST

1 General

1.1 Scope

1.1.1 (1/1/2021)

This Appendix is to be applied according to the scope defined in Sec 1, [11].

1.1.2 (1/1/2021)

This Appendix specifies the requirements for test procedures and test conditions when using the isothermal crack arrest test to determine a valid test result under isothermal conditions and in order to establish the crack arrest temperature (CAT). This Appendix is applicable to steels with thickness over 50mm and not greater than 100mm.

1.1.3 (1/1/2021)

This method uses an isothermal temperature in the test specimen being evaluated. Unless otherwise specified in this Appendix, the other test parameters are to be in accordance with App 4.

1.1.4 (1/1/2021)

Sec 1, Tab 34 gives the relevant requirements for the brittle crack arrest property described by the crack arrest temperature (CAT).

1.1.5 (1/1/2021)

The manufacturer is to submit the test procedure to the Society for review prior to testing.

1.2 Symbols and their significance

1.2.1 (1/1/2021)

Tab 1 supplements App 4, Tab 1 with specific symbols for the isothermal test.

2 Testing equipment

2.1 General

2.1.1 (1/1/2021)

The test equipment to be used is to be of the hydraulic type of sufficient capacity to provide a tensile load equivalent to 2/3 of SMYS of the steel grade to be approved

2.1.2 (1/1/2021)

The temperature control system is to be equipped to maintain the temperature in the specified region of the specimen within $\pm 2^\circ\text{C}$ from T_{target}

2.1.3 (1/1/2021)

Methods for initiating the brittle crack may be of drop weight type, air gun type or double tension tab plate type

2.1.4 (1/1/2021)

The detailed requirements for testing equipment are specified in App 4, [2].

3 Test specimens

3.1 Impact type crack initiation

3.1.1 (1/1/2021)

Test specimens are to be in accordance with App 4, [3], unless otherwise specified in this Appendix

3.1.2 (1/1/2021)

Specimen dimensions are shown in Fig 1. The test specimen width, W is to be 500mm. The test specimen length, L is to be equal to or greater than 500mm

3.1.3 (1/1/2021)

V-shape notch for brittle crack initiation is machined on the specimen edge of the impact side. The whole machined notch length is to be equal to 29mm with a tolerance range of $\pm 1\text{mm}$

Table 1 : Nomenclature supplementary to Tab 1 of Appendix 4 (1/1/2021)

Symbol	Unit	Significance
t	mm	Test specimen thickness
L	mm	Test specimen length
W	mm	Test specimen width
a _{MN}	mm	Machined notch length on specimen edge
L _{SG}	mm	Side groove length on side surface from the specimen edge. LSG is defined as a groove length with constant depth except a curved section in depth at side groove end
d _{SG}	mm	Side groove depth in section with constant depth
L _{EB - min}	mm	Minimum length between specimen edge and electron beam re-melting zone front
L _{EB-s1, -s2}	mm	Length between specimen edge and electron beam re-melting zone front appeared on both specimen side surfaces
L _{LTG}	mm	Local temperature gradient zone length for brittle crack runaway
a _{arrest}	mm	Arrested crack length
T _{target}	°C	Target test temperature
T _{test}	°C	Defined test temperature
T _{arrest}	°C	Target test temperature at which valid brittle crack arrest behaviour is observed
σ	N/mm ²	Applied test stress at cross section of W x t
SMYS	N/mm ²	Specified minimum yield strength of the tested steel grade to be approved
CAT	°C	Crack arrest temperature, the lowest temperature, T _{arrest} , at which running brittle crack is arrested

3.1.4 (1/1/2021)

Requirements for side grooves are described in [3.4].

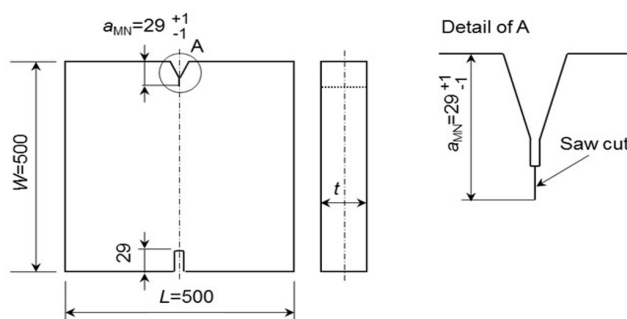
Figure 1 : Test specimen dimensions for an impact type specimen (1/1/2021)

Note 1: Saw cut notch radius may be machined in the range 0,1mm R and 1mm R in order to control a brittle crack initiation at test.

3.2 Double tension type crack initiation**3.2.1 (1/1/2021)**

Reference is to be made to Annex B in App 4, [9] for the shape and sizes in secondary loading tab and secondary loading method for brittle crack initiation

3.2.2 (1/1/2021)

In a double tension type test, the secondary loading tab plate may be subject to further cooling to enhance an easy brittle crack initiation.

3.3 Embrittled zone setting**3.3.1 (1/1/2021)**

An embrittled zone is to be applied to ensure the initiation of a running brittle crack. Either Electron Beam Welding (EBW) or Local Temperature Gradient (LTG) may be adopted to facilitate the embrittled zone

3.3.2 (1/1/2021)

In EBW embrittlement, electron beam welding is applied along the expected initial crack propagation path, which is the centre line of the specimen in front of the machined V-notch

3.3.3 (1/1/2021)

The complete penetration through the specimen thickness is required along the embrittled zone. One side EBW penetration is preferable, but dual sides EB penetration may be also adopted when the EBW power is not enough to achieve the complete penetration by one side EBW

3.3.4 (1/1/2021)

The EBW embrittlement is recommended to be prepared before specimen contour machining

3.3.5 (1/1/2021)

In EBW embrittlement, zone is to be of an appropriate quality

Note 1: EBW occasionally behaves in an un-stable manner at start and end points. EBW line is recommended to start from the embrittled zone tip side to the specimen edge with an increasing power control or go/return manner at start point to keep the stable EBW.

3.3.6 (1/1/2021)

In LTG system, the specified local temperature gradient between machined notch tip and isothermal test region is regulated after isothermal temperature control. LTG temperature control is to be achieved just before brittle crack initiation, nevertheless the steady temperature gradient through the thickness is to be ensured.

3.4 Side grooves

3.4.1 (1/1/2021)

Side grooves on side surface can be machined along the embrittled zone to keep brittle crack propagation straight. Side grooves are to be machined in the specified cases as specified in this section.

3.4.2 (1/1/2021)

In EBW embrittlement, side grooves are not necessarily mandatory. Use of EBW avoids the shear lips. However, when shear lips are evident on the fractured specimen, e.g. shear lips over 1mm in thickness in either side then side grooves should be machined to suppress the shear lips.

3.4.3 (1/1/2021)

In LTG embrittlement, side grooves are mandatory. Side grooves with the same shape and size are to be machined on both side surfaces.

3.4.4 (1/1/2021)

The length of side groove, L_{SG} is to be no shorter than the sum of the required embrittled zone length of 150mm.

3.4.5 (1/1/2021)

When side grooves would be introduced, the side groove depth, the tip radius and the open angle are not regulated, but are adequately selected in order to avoid any shear lips over 1mm thickness in either side. An example of side groove dimensions are shown in Fig 2.

3.4.6 (1/1/2021)

Side groove end is to be machined to make a groove depth gradually shallow with a curvature larger than or equal to groove depth, d_{SG} . Side groove length, L_{SG} is defined as a groove length with constant depth except a curved section in depth at side groove end.

Figure 2 : Side groove configuration and dimensions (1/1/2021)

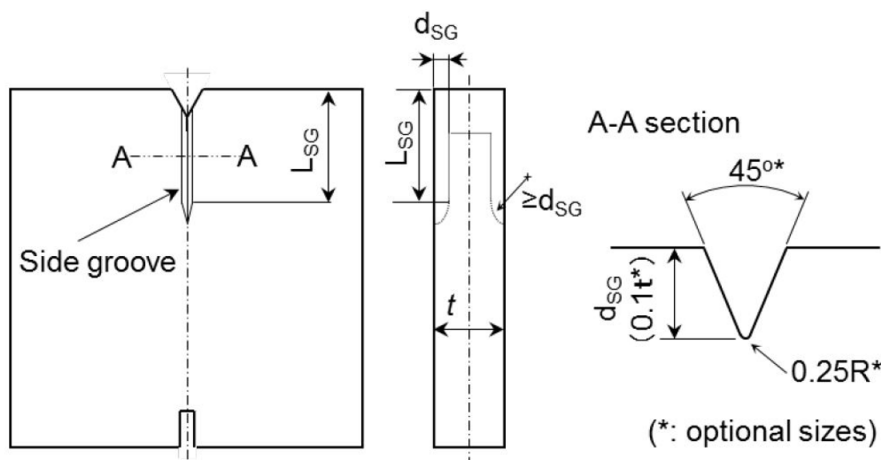

3.5 Nominal length of embrittled zone

3.5.1 (1/1/2021)

The length of embrittled zone is to be nominally equal to 150mm in both systems of EBW and LTG.

3.5.2 (1/1/2021)

EBW zone length is regulated by three measurements on the fracture surface after test as shown in Fig 3 , LEB-min

between specimen edge and EBW front line, and LEB-s1 and LEB-s2.

3.5.3 (1/1/2021)

The minimum length between specimen edge and EBW front line, LEB-min should be no smaller than 150mm. However, it can be acceptable even if LEB-min is no smaller than 150mm-0,2t, where t is specimen thickness. When

LEB-min is smaller than 150mm, a temperature safety margin is to be considered into Ttest (See [7.1.2])

3.5.4 (1/1/2021)

Another two are the lengths between specimen edge and EBW front appeared on both side surfaces, as denoted with

LEB-s1 and LEB-s2. Both of LEB-s1 and LEB-s2 are to be no smaller than 150mm.

3.5.5 (1/1/2021)

In LTG system, LLTG is set as 150mm.

Figure 3 : Definition of EBW length (1/1/2021)

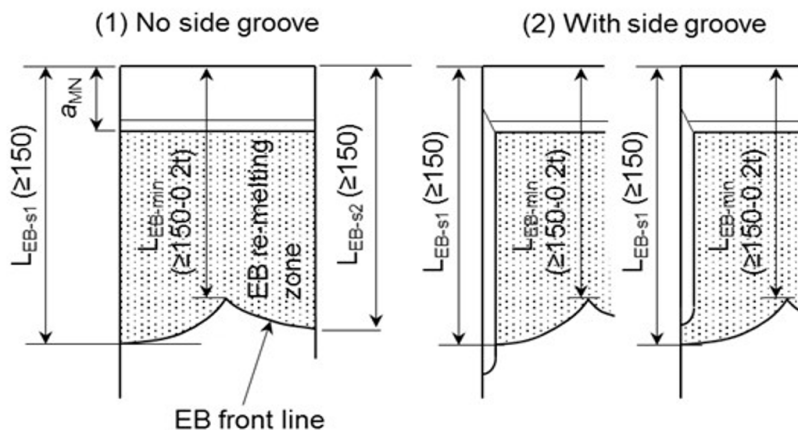

3.6 Tab plate / pin chuck details and welding of test specimen to tab plates

3.6.1 (1/1/2021)

The configuration and size of tab plates and pin chucks is to be referred to App 4, [3.2]. The welding distortion in the integrated specimen, which is welded with specimen, tab plates and pin chucks, is to be also within the requirement in App 4, [3.3].

be applied at higher temperature than ambient temperature when brittle crack initiation is expected at preloading process. However, the specimen is to not be subjected to temperature higher than 100°C.

4 Test method

4.1 Preloading

4.1.1 (1/1/2021)

Preloading at room temperature can be applied to avoid unexpected brittle crack initiation at test. The applied load value is to be no greater than the test stress. Preloading can

4.2 Temperature measurement and control

4.2.1 (1/1/2021)

Temperature control plan showing the number and position of thermocouples is to be in accordance with this section.

4.2.2 (1/1/2021)

Thermocouples are to be attached to both sides of the test specimen at a maximum interval of 50mm in the whole width and in the longitudinal direction at the test specimen centre position (0,5 W) within the range of ±100mm from the centreline in the longitudinal direction, refer to Fig 4.

Figure 4 : Locations of temperature measurement (1/1/2021)

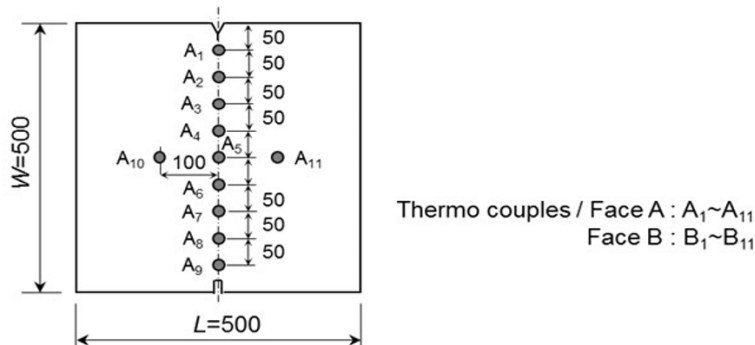

4.2.3 (1/1/2021)

For EBW embrittlement:

- The temperatures of the thermocouples across the range of 0,3W-0,7W in both width and longitudinal direc-

tions are to be controlled within ± 2°C of the target test temperature, T_{target}

- When all measured temperatures across the range of 0,3W-0,7W have reached T_{target}, steady temperature control is to be kept at least for 10 + 0,1 x t [mm] min-

utes to ensure a uniform temperature distribution into mid-thickness prior to applying test load

- The machined notch tip can be locally cooled to easily initiate brittle crack. Nevertheless, the local cooling is to not disturb the steady temperature control across the range of 0,3W-0,7W.

4.2.4 (1/1/2021)

For LTG embrittlement:

- In LTG system, in addition to the temperature measurements shown in Fig 4, the additional temperature measurement at the machine notch tip, A₀ and B₀ is required. Thermocouples positions within LTG zone are shown in Fig 5.

Figure 5 : Detail of LTG zone and additional thermocouple A₀ (1/1/2021)

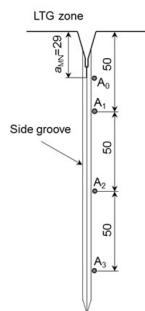

- The temperatures of the thermocouples across the range of 0,3W-0,7W in both width and longitudinal directions are to be controlled within ± 2°C of the target test temperature, T_{target}. However, the temperature measure-

ment at 0,3W (location of A₃ and B₃) is to be in accordance with f) below

- Once the all measured temperatures across the range of 0,3W-0,7W have reached T_{target}, steady temperature control is to be kept at least for 10 + 0,1 x t [mm] minutes to ensure a uniform temperature distribution into mid-thickness, then the test load is applied
- LTG is controlled by local cooling around the machined notch tip. LTG profile is to be recorded by the temperature measurements from A₀ to A₃ shown in Fig 6
- LTG zone is established by temperature gradients in three zones, Zone I, Zone II and Zone III. The acceptable range for each temperature gradient is listed Tab 2
- Two temperature measurements at A₂, B₂ and A₃, B₃ are to be satisfied the following requirements:
 - T at A₃, T at B₃ < T_{target} - 2°C
 - T at A₂ < T at A₃ - 5°C
 - T at B₂ < T at B₃ - 5°C
- No requirements for T at A₀ and T at A₁ temperatures when T at A₃ and T at A₂ satisfy the requirements above. Face B is the same
- The temperatures from A₀, B₀ to A₃, B₃ should be decided at test planning stage refer to Tab 2 which gives the recommended temperature gradients in three zones, Zone I, Zone II and Zone III in LTG zone
- The temperature profile in LTG zone mentioned above is to be ensured after holding time at least for 10 + 0,1 x t [mm] minutes to ensure a uniform temperature distribution into mid-thickness before brittle crack initiation
- The acceptance of LTG in the test is to be decided from Tab 2 based on the measured temperatures from A₀ to A₃.

Figure 6 : Schematic temperature gradient profile in LTG zone (1/1/2021)

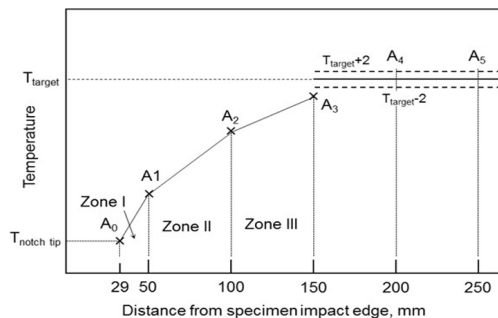

Table 2 : Acceptable LTG range (1/1/2021)

Zone	Location from edge	Acceptable range of temperature gradient
Zone I	29mm - 50mm	2,00 °C/mm - 2,30 °C/mm
Zone II	50mm - 100mm	0,25 °C/mm - 0,60 °C/mm

Zone	Location from edge	Acceptable range of temperature gradient
Zone III (1)	100mm - 150mm	0,10 °C/mm - 0,20 °C/mm
(1) The Zone III arrangement is mandatory		

4.3 Loading and brittle crack initiation

4.3.1 (1/1/2021)

Prior to testing, a target test temperature (T_{target}) is to be selected.

4.3.2 (1/1/2021)

Test procedures are to be in accordance with App 4, [5] except that the applied stress is to be 2/3 of SMYS of the steel grade tested.

4.3.3 (1/1/2021)

The test load is to be held at the test target load or higher for a minimum of 30 seconds prior to crack initiation.

4.3.4 (1/1/2021)

Brittle crack can be initiated by impact or secondary tab tension after all of the temperature measurements and the applied force are recorded.

5 Measurements after test and test validation judgement

5.1 Brittle crack initiation and validation

5.1.1 (1/1/2021)

If brittle crack spontaneously initiates before the test force is achieved or the specified hold time at the test force is not achieved, the test is to be invalid.

5.1.2 (1/1/2021)

If brittle crack spontaneously initiates without impact or secondary tab tension but after the specified time at the test force is achieved, the test is considered as a valid initiation. The following validation judgments of crack path and fracture appearance is to be examined.

5.2 Crack path examination and validation

5.2.1 (1/1/2021)

When brittle crack path in embrittled zone deviates from EBW line or side groove in LTG system due to crack deflection and/or crack branching, the test is to be considered as invalid.

5.2.2 (1/1/2021)

All of the crack path from embrittled zone end is to be within the range shown in Fig 7. If not, the test is to be considered as invalid.

Figure 7 : Allowable range of main crack propagation path (1/1/2021)

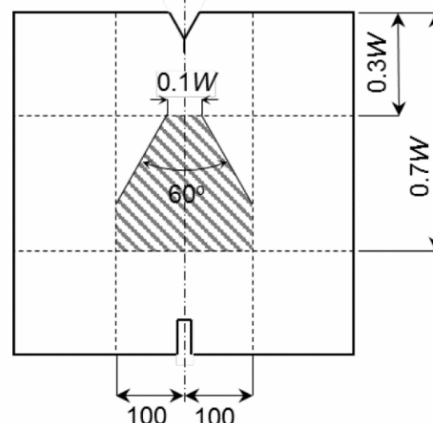

5.3 Fracture surface examination, crack length measurement and their validation

5.3.1 (1/1/2021)

Fracture surface is to be observed and examined. The crack "initiation" and "propagation" are to be checked for validity and judgements recorded. The crack "arrest" positions are to be measured and recorded.

5.3.2 (1/1/2021)

When crack initiation trigger point is clearly detected at side groove root, other than the V-notch tip, the test is to be invalid.

5.3.3 (1/1/2021)

In EBW embrittlement setting, EBW zone length is quantified by three measurements of LEB-s1, LEB-s2 and LEB-min, which are defined in [3.5]. When either or both of LEB-s1 and LEB-s2 are smaller than 150mm, the test is to be invalid. When LEB-min is smaller than 150mm-0,2t, the test is to be invalid.

5.3.4 (1/1/2021)

When the shear lip with thickness over 1mm in either side near side surfaces of embrittled zone are visibly observed independent of the specimens with or without side grooves, the test is to be invalid.

5.3.5 (1/1/2021)

In EBW embrittlement setting, the penetration of brittle crack beyond the EBW front line is to be visually examined. When any brittle fracture appearance area continued from the EB front line is not detected, the test is to be invalid.

5.3.6 (1/1/2021)

The weld defects in EBW embrittled zone are to be visually examined. If detected, it are to be quantified. A projecting length of defect on the thickness line through EB weld region along brittle crack path is to be measured, and the total occupation ratio of the projected defect part to the total thickness is defined as defect line fraction (see Fig 8).

When the defects line fraction is larger than 10 %, the test is to be invalid

5.3.7 (1/1/2021)

In EBW embrittlement by dual sides' penetration, a gap on embrittled zone fracture surface which is induced by miss meeting of dual fusion lines is visibly detected at an overlapped line of dual side penetration, the test is to be invalid.

Figure 8 : Counting procedure of defect line fraction (1/1/2021)

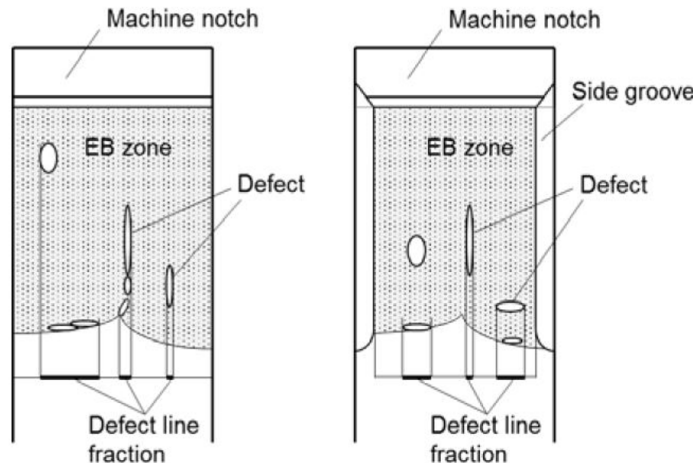

6 Judgement of "arrest" or "propagate"

6.1 General

6.1.1 (1/1/2021)

The final test judgment of "arrest", "propagate" or "invalid" is decided by the following requirements:

- If initiated brittle crack is arrested and the tested specimen is not broken into two pieces, the fracture surfaces should be exposed with the procedures specified in App 4, [5.4] and [5.5]
- When the specimen was not broken into two pieces during testing, the arrested crack length, a_{arrest} is to be measured on the fractured surfaces. The length from the specimen edge of impact side to the arrested crack tip (the longest position) is defined as a_{arrest}
- For LTG and EBW, a_{arrest} is to be greater than L_{LTG} and $L_{\text{EB-s1}}$, $L_{\text{EB-s2}}$ or $L_{\text{EB-min}}$. If not, the test is to be considered as invalid
- Even when the specimen was broken into two pieces during testing, it can be considered as "arrest" when brittle crack re-initiation is clearly evident. Even in the fracture surface all occupied by brittle fracture, when a part of brittle crack surface from embrittled zone is continuously surrounded by thin ductile tear line, the test can be judged as re-initiation behaviour. If so, the maximum crack length of the part surrounded tear line can be measured as a_{arrest} . If re-initiation is not visibly evident, the test is judged as "propagate"
- The test is judged as "arrest" when the value of a_{arrest} is no greater than 0,7W. If not, the test is judged as "propagate".

7 T_{test} , T_{arrest} and CAT determination

7.1 T_{test} determination

7.1.1 (1/1/2021)

It is to be ensured on the thermocouple measured record that all temperature measurements across the range of 0,3W ~ 0,7W in both width and longitudinal direction are in the range of $T_{\text{target}} \pm 2^\circ\text{C}$ at brittle crack initiation. If not, the test is to be invalid. However, the temperature measurement at 0,3W (location of A3 and B3) in LTG system is to be exempted from this requirement.

7.1.2 (1/1/2021)

If $L_{\text{EB-min}}$ in EBW embrittlement is no smaller than 150mm, T_{test} can be defined to equal with T_{target} . If not, T_{test} is to be equalled with $T_{\text{target}} + 5^\circ\text{C}$.

7.1.3 (1/1/2021)

In LTG embrittlement, T_{test} can be equalled with T_{target} .

7.1.4 (1/1/2021)

The final arrest judgment at T_{test} is concluded by at least two tests at the same test condition which are judged as "arrest".

7.2 T_{arrest} determination

7.2.1 (1/1/2021)

When at least repeated two "arrest" tests appear at the same T_{target} , brittle crack arrest behaviour at T_{target} will be decided ($T_{\text{arrest}} = T_{\text{target}}$). When a "propagate" test result is included in the multiple test results at the same T_{target} , the T_{target} cannot to be decided as T_{arrest} .

7.3 CAT determination

7.3.1 (1/1/2021)

When CAT is determined, one "propagate" test is needed in addition to two "arrest" tests. The target test temperature,

T_{target} for "propagate" test is recommended to select 5°C lower than T_{arrest} . The minimum temperature of T_{arrest} is determined as CAT

7.3.2 (1/1/2021)

With only the "arrest" tests, without "propagation" test, it is decided only that CAT is lower than T_{test} in the two "arrest" tests, i.e. not deterministic CAT.

8 Reporting

8.1 General

8.1.1 (1/1/2021)

The following items are to be reported:

- a) Test material: grade and thickness
- b) Test machine capacity
- c) Test specimen dimensions: thickness t ; width W and length L ; notch details and length a_{MN} , side groove details if machined
- d) Embrittled zone type: EBW or LTG embrittlement
- e) Integrated specimen dimensions: Tab plate thickness, tab plate width, integrated specimen unit length including the tab plates, and distance between the loading pins, angular distortion and linear misalignment
- f) Brittle crack trigger information: impact type or double tension. If impact type, drop weight type or air gun type, and applied impact energy
- g) Test conditions; Applied load; preload stress, test stress
 - Judgements for preload stress limit, hold time requirement under steady test stress
- h) Test temperature: complete temperature records with thermocouple positions for measured temperatures (figure and/or table) and target test temperature
 - Judgements for temperature scatter limit in isothermal region
 - Judgement for local temperature gradient requirements and holding time requirement after steady local temperature gradient before brittle crack trigger, if LTG system is used
- i) Crack path and fracture surface: tested specimen photos showing fracture surfaces on both sides and crack path

side view; Mark at "embrittled zone tip" and "arrest" positions

- Judgment for crack path requirement
 - Judgment for cleavage trigger location (whether side groove edge or V-notch edge)
- j) Embrittled zone information:
- When EBW is used: $L_{\text{EB-s1}}$, $L_{\text{EB-s2}}$ and $L_{\text{EB-min}}$
- Judgement for shear lip thickness requirement
 - Judgement for EBW defects requirement
 - Judgement for EBW lengths, $L_{\text{EB-s1}}$, $L_{\text{EB-s2}}$ and $L_{\text{EB-min}}$ requirements
- When LTG is used: L_{LTG}
- Judgment for shear lip thickness requirement
- Test results:
- When the specimen did not break into two pieces after brittle crack trigger, arrested crack length a_{arrest}
- When the specimen broke into two pieces after brittle crack trigger
- judgement whether brittle crack re-initiation or not
- If so, arrested crack length a_{arrest} :
- Judgement for a_{arrest} in the valid range ($0,3W < a_{\text{arrest}} \leq 0,7W$)
 - Final judgement either "arrest", "propagate" or "invalid"
- k) Dynamic measurement results: History of crack propagation velocity, and strain change at pin chucks, if needed

9 Use of test for material qualification testing

9.1 General

9.1.1 (1/1/2021)

Where required, the method can also be used for determining the lowest temperature at which a steel can arrest a running brittle crack (the determined CAT) as the material property characteristic in accordance with [7.3].

APPENDIX 6

MATERIAL AND WELDING FOR THE STORAGE AND TRANSPORT OF LIQUEFIED GASES IN BULK AND FOR THE USE OF GASES OR OTHER LOW-FLASHPOINT FUELS

1 General

1.1 Application

1.1.1 (1/7/2022)

The requirements in this Appendix apply, in addition to the ones prescribed in the International Code for the Construction and Equipment of Ships Carrying Liquefied Gases in Bulk (IGC Code) or International Code of Safety for Ships using Gases or other low-flashpoint Fuels (IGF Code), to materials and welding intended to be used in:

- liquefied gas carriers, for the storage and transport of liquefied gases in bulk; and
- ships using gases or other low-flashpoint fuels.

2 Material requirements

2.1 Plates, pipes (seamless and welded), sections and forgings for cargo tanks, fuel tanks and process pressure vessels for design temperatures not lower than 0°C

2.1.1 (1/7/2022)

In addition to IGC Code Table 6.1 or IGF Code Table 7.1 for design temperature not lower than 0°C, Tab 1 applies.

2.2 Plates, sections and forgings for cargo tanks, fuel tanks, secondary barriers and process pressure vessels for design temperatures below 0°C and down to -55°C

2.2.1 (1/7/2022)

In addition to IGC Code Table 6.2 or IGF Code Table 7.2, Tab 2 and Tab 3 apply.

2.3 Plates, sections and forgings for cargo tanks, fuel tanks, secondary barriers and process pressure vessels for design temperatures below -55°C and down to -165°C

2.3.1 (1/7/2022)

In addition to IGC Code Table 6.3 or IGF Code Table 7.3, Tab 4 applies.

Table 1 : Plates, pipes (seamless and welded), sections and forgings for cargo tanks, fuel tanks and process pressure vessels for design temperatures not lower than 0°C (1/7/2022)

CHARPY V-NOTCH IMPACT TEST REQUIREMENTS		
TEST TEMPERATURE	Thickness t (mm)	Test temperature (°C)
	40 < t ≤ 50 ⁽¹⁾	-20 ⁽²⁾
	40 < t ≤ 50 ⁽¹⁾	-30 ⁽³⁾

Notes:

- A further set of impact test at mid thickness for products with t>40mm is required except rolled steels specified in Sec 1, [2] or Sec 1, [3].
- Applies to type C independent tanks and process pressure vessels. In addition, post-weld stress relief heat treatment is to be performed. Exemption to post-weld stress relief heat treatment based on alternative approach (e.g. Engineering Critical Assessment) is to be approved by the Society or is to be to recognized standards.
- Applies to cargo tank or fuel tank other than type C.

Table 2 : Plates, sections and forgings for cargo tanks, fuel tanks, secondary barriers and process pressure vessels for design temperatures below 0°C and strictly down to -10°C (1/7/2022)

CHARPY V-NOTCH IMPACT TEST REQUIREMENTS		
TEST TEMPERATURE	Thickness t (mm)	Test temperature (°C)
	40 < t ≤ 50 ⁽¹⁾	5°C below design temperature or -20°C, whichever is lower ⁽²⁾
	40 < t ≤ 45 ⁽¹⁾	25 °C below design temperature ⁽³⁾
	45 < t ≤ 50 ⁽¹⁾	30 °C below design temperature ⁽³⁾

Notes:

(1) A further set of impact test at mid thickness for products with t>40mm is required except rolled steels specified in Sec 1, [2] or Sec 1, [3].

(2) Applies to type C independent tanks and process pressure vessels. In addition, post-weld stress relief heat treatment is to be performed. Exemption to post-weld stress relief heat treatment based on alternative approach (e.g. Engineering Critical Assessment) is to be approved by the Society or is to be recognized standards.

(3) Applies to cargo tank or fuel tank other than type C.

Table 3 : Plates, sections and forgings for cargo tanks, fuel tanks, secondary barriers and process pressure vessels for design temperatures below -10°C and down to -55°C (1/7/2022)

CHARPY V-NOTCH IMPACT TEST REQUIREMENTS		
TEST TEMPERATURE	Thickness t (mm)	Test temperature (°C)
	40 < t ≤ 50 ⁽¹⁾	5°C below design temperature or -20°C, whichever is lower ⁽²⁾
	40 < t ≤ 45 ⁽¹⁾	25 °C below design temperature ⁽³⁾
	45 < t ≤ 50 ⁽¹⁾	30 °C below design temperature ⁽³⁾

Notes:

(1) A further set of impact test at mid thickness for products with t>40mm is required except rolled steels specified in Sec 1, [2] or Sec 1, [3].

(2) IGC code section 6.6.2.2 applies with regards to post-weld stress relief heat treatment. Exemption to post-weld stress relief heat treatment based on alternative approach (e.g. Engineering Critical Assessment) is to be approved by the Society or is to be recognized standards.

(3) Applies to cargo tank or fuel tank other than type C.

Table 4 : Plates, sections and forgings for cargo tanks, fuel tanks, secondary barriers and process pressure vessels for design temperatures below -55°C and down to -165°C (1/7/2022)

CHARPY V-NOTCH IMPACT TEST REQUIREMENTS		
TEST TEMPERATURE	Thickness t (mm)	Test temperature (°C)
	40 < t ≤ 45 ⁽¹⁾	25 °C below design temperature
	45 < t ≤ 50 ⁽¹⁾	30 °C below design temperature

Notes:

(1) A further set of impact test at mid thickness for products with t>40mm is required except rolled steels specified in Sec 1, [2] or Sec 1, [3].

Part D
Materials and Welding

Chapter 3
NON FERROUS METAL

SECTION 1 COPPER AND COPPER ALLOYS

SECTION 2 ALUMINIUM ALLOYS

SECTION 1

COPPER AND COPPER ALLOYS

1 General

1.1 Application

1.1.1 The requirements of this Section apply in addition to those of Chapter 1 and Chapter 2 to copper or copper alloy tubes and castings.

The requirements for propeller and propeller blade castings are given in Ch 4, Sec 2.

1.1.2 Copper alloys and products other than those indicated in this Section complying with national or international standards or proprietary specifications deemed equivalent to these requirements may be accepted subject to the approval of the Society.

1.1.3 Where welding is envisaged, procedures and preparations for the welded joints are to be submitted for approval.

1.2 Manufacture

1.2.1 The manufacturing procedure and heat treatments suitable to obtain products having the required properties are, in principle, left to the discretion of the Manufacturer.

1.2.2 The manufacturing process is to ensure that copper or copper alloy products are free from internal or surface defects which may impair their proper workability and use.

1.3 Testing

1.3.1 Tensile tests required in this Section are to be carried out on cylindrical test specimens of the type defined in Ch 1, Sec 2, [2.1.3] with a gauge length equal to:

$$L_0 = 5,65\sqrt{S_0} = 5d \text{ (specimen A)}$$

1.4 Documentation and certification

1.4.1 The testing documentation is to contain the information required in Ch 1, Sec 1, [4.2.1].

2 Copper alloy castings

2.1 Application

2.1.1 The requirements of this Article apply to copper alloy castings intended for various uses, with the exception of castings intended for propeller and propeller blades.

2.2 Manufacture

2.2.1 The approval of the manufacturing procedure may be required by the Society on a case-by-case basis for products intended for important uses.

2.3 Condition of supply

2.3.1 Copper alloy castings may be supplied, at the discretion of the Manufacturer, in either the as cast or heat treated condition unless otherwise specified.

2.3.2 When castings are supplied in the heat treated condition, the Manufacturer is to provide the Surveyor with the details of the heat treatment used on the casting.

2.4 Chemical composition

2.4.1 The chemical compositions are to comply with the requirements given in Tab 1.

2.4.2 The Manufacturer is to issue a cast certificate. When castings are made from ingots for which an analysis is already available, and provided that no alloy additions are made, the certified analysis made by the maker of the ingots may be accepted subject to occasional checks as requested by the Surveyor.

2.5 Mechanical properties

2.5.1 Mechanical properties are to comply with the appropriate requirements specified in Tab 2.

2.6 Mechanical tests

2.6.1 Test material sufficient for the required tests and possible re-tests is to be provided for each copper alloy casting.

2.6.2 The batch is to be made by castings from the same heat, and treated in the same furnace charge if delivered in the heat treated condition.

2.6.3 In the case of heat treated material, test samples are to be treated in the same way and, in general, together with the material they represent.

2.6.4 For each test sample, a tensile test specimen is prepared, machined at the dimensions specified in [1.3].

Table 1 : Castings - Chemical composition (%)

Name of alloy	Cu	Sn	Pb	Zn	Fe	Ni	Al	Mn	Si	P	Others
High tensile brass	57/65	≤ 1,0	≤ 0,5	remainder	0,5/2,0	≤ 3,0	0,5/2,5	0,1/3,0	≤ 0,10		Sb+P+As ≤ 0,40
Leaded bronze	80/87 (1)	4,0/6,0	8,0/11	≤ 2,0	≤ 0,25	≤ 2,0	≤ 0,01	≤ 0,2	≤ 0,01	≤ 0,10	S ≤ 0,10
Phosphor bronze	86/89,5 (1)	9,5/12	≤ 0,5	≤ 0,5	≤ 0,10	≤ 0,2	≤ 0,01	--	≤ 0,02	0,15/1,5	
Bronze Cu Sn10 Zn2 (Gunmetal)	86/89	9,0/11	≤ 1,5	1,0/3,0	≤ 0,25	≤ 2,0	≤ 0,01	≤ 0,2	≤ 0,01	0,05	S ≤ 0,10 Sb ≤ 0,30
Bronze Cu Pb5 Sn5 Zn5 (leaded Gunmetal)	84/86 (1)	4,0/6,0	4,0/6,0	4,0/6,0	≤ 0,30	≤ 2,5	≤ 0,01	--	≤ 0,01	0,05	
Copper- aluminium	88/92 (1)	≤ 0,30	≤ 0,02 (2)	≤ 0,40	2,0/5,0	≤ 3,0	8,5/11	≤ 1,0	≤ 0,20		
Nickel copper aluminium	> 76	≤ 0,20	≤ 0,02 (2)	≤ 0,50	3,5/5,5	3,5/6,5	8,0/11 (4)	≤ 3,0	≤ 0,10		Cu+Fe+Ni+ Al+Mn≥99,2
Copper-nickel 90 / 10	remain der	--	≤ 0,02 (2)	≤ 0,50 (2)	1,0/1,8	9,0/11	--	0,5/1,0	--	0,20	S ≤ 0,20 (3) C ≤ 0,05
Copper-nickel 70 / 30	remain der	--	≤ 0,02 (2)	≤ 0,50 (2)	0,4/1,0	29/32	--	0,5/1,5	--	0,20	S ≤ 0,20 C ≤ 0,05

(1) Nickel included.

(2) When no welding is to be done on the pieces, Pb content may be in the range from 0,1% to 0,3%, Zn content may be up to 1,0% and there are no requirements for C, S and P.

(3) Cu + Fe + Mn + Ni +Pb ≥ 99,5%

(4) If this nickel copper aluminium is to withstand sea corrosion, it is necessary that Al ≤ 8,2 + Ni/2

Table 2 : Castings - Mechanical characteristics

Name of Alloy	R _m (N/mm ²)	R _e at 0,2% (N/mm ²) (1)	A (%) on 5d (or 5,65.√S ₀)
High tensile brass	≥ 450	≥ 170	≥ 20
Leaded bronze	≥ 230	≥ 130	≥ 9
Phosphor bronze	≥ 220	≥ 130	≥ 6
Bronze (Gunmetal) Cu Sn10 Zn2	≥ 240	≥ 120	≥ 12
Bronze Cu Pb5 Sn5 Zn5 (leaded Gunmetal)	≥ 200	≥ 90	≥ 13
Copper-aluminium	≥ 450	≥ 160	≥ 15
Nickel copper aluminium	≥ 600	≥ 250	≥ 12
Copper-nickel 90 / 10	≥ 320	≥ 160	≥ 20
Copper-nickel 70 / 30	≥ 420	≥ 220	≥ 20

(1) Values of yield stress at 0,2% offset are indicated for guidance only and, unless specially requested, are not required to be checked during the tensile test.

2.7 Visual and non-destructive examination

2.7.1 All castings are to be cleaned and adequately prepared for inspection.

2.7.2 The Manufacturer is responsible for compliance with dimensions and tolerances.

2.7.3 Before acceptance, all castings are to be presented for visual examination. This is to include the examination of the external and internal surfaces of each casting of the batch and, if necessary, the dye-penetrant test for copper-aluminium and copper-nickel castings.

In addition, for certain copper alloy castings submitted to heavy stresses, the Surveyor may require radiographic and ultrasonic testing.

2.7.4 Unless otherwise indicated in these Rules, copper alloy castings submitted to pressure are to undergo a hydrostatic test at a pressure equal to twice the service pressure.

The Manufacturer is to issue a certificate for these tests and the Surveyor may ask to attend all or part of such tests.

2.8 Rectification of defective castings

2.8.1 The evaluation of defects, where present, and the necessity and the acceptance of the means of rectification are left to the discretion of the Surveyor; to this end, additional checks may be required.

2.8.2 The Surveyor may accept that castings containing local porosities are rectified by impregnation with a suitable plastic filler, provided that the porosities do not adversely affect the mechanical strength of the casting.

2.8.3 Welded repairs are not acceptable, as a rule, unless expressly authorised by the Surveyor.

Any proposal to repair a defective casting by welding is to be previously submitted to the Surveyor, who may require that tests are performed to qualify the proposed welding procedure.

2.9 Identification and marking

2.9.1 The Manufacturer is to adopt a system of identification which will enable all finished castings to be traced to the original cast.

In addition to the indications required in Ch 1, Sec 1, [4.1.3], all castings which have been tested and inspected with satisfactory results are to be marked with the following details:

- a) Manufacturer's name or trade mark
- b) identification number, cast number or other markings which will enable the full history of the casting to be traced
- c) test pressure, where applicable.

2.9.2 Modified arrangements for identification and marking of small castings manufactured in large numbers may be agreed with the Surveyor.

3 Copper alloy pipes

3.1 Application

3.1.1 The requirements of this Article apply to copper alloy pipes intended for condensers, heat exchangers and pressure lines.

3.2 Condition of supply

3.2.1 Copper and copper alloy pipes are to be delivered annealed (recrystallised with fine grain). Copper pipes may also be delivered hard drawn.

3.2.2 Aluminium brass pipes may additionally be required to be given a suitable stress relieving heat treatment when subjected to a cold straightening operation after annealing.

3.3 Chemical composition

3.3.1 The chemical composition of copper alloys used for the manufacture of pipes is to comply with the requirements given in Tab 3 and a corresponding heat certificate is to be issued by the Manufacturer.

3.4 Mechanical properties

3.4.1 The mechanical properties are to comply with the appropriate requirements given in Tab 4.

3.5 Mechanical tests

3.5.1 One series of tests is to be conducted on each batch of 200 pipes coming from the same fabrication and same heat, and having the same size and delivery condition (heat treatment).

3.5.2 At least one length is to be selected at random from each batch for the following tests:

- one tensile test
- one flattening test
- one drift expanding test.

The procedures for mechanical tests and the dimensions of the test specimens are to be in accordance with Ch 1, Sec 2, with the additions and/or modifications as per the present item.

3.5.3 A tensile test is to be carried out on a specimen consisting of a pipe length of full section, or of a strip cut longitudinally in the pipe and of the same thickness as the pipe.

3.5.4 The flattening test consists of slowly flattening a section of pipe 50 mm long by one stroke of a press.

After flattening to a distance between platens equal to three times the thickness of the pipe, no cracking, rupture or defects are to be visible to the unaided eye on the external surface of the pipe.

Table 3 : Pipes - Chemical composition (%)

Name of Alloys	Cu (1)	Sn	Al	Ni (1)	Pb	Fe	Zn	Mn	As	Residual elements
Copper-phosphorus (arsenical or non arsenical)	≥ 99,85								0,30/0,50	P=0,013/0,050 deoxidised
Tin Brass (naval)	70/73	0,9/1,2			≤ 0,07	≤ 0,06	remainder		0,02/0,06	total impurities +Pb+Fe ≤ 0,3
Aluminium Brass	76/79		1,8/2,5		≤ 0,07	≤ 0,06	remainder		0,02/0,06	total impurities +Pb+Fe ≤ 0,3
Copper-nickel 90/10 (2)	remainder			9,0/11	≤ 0,02	1,0/2,0	≤ 0,5	0,3/1,0		C ≤ 0,05-S+P ≤ 0,02 total others ≤ 0,1
Copper-nickel 70/30 (2)	remainder			29/33	≤ 0,02	0,4/1,0	≤ 0,5	0,5/1,5		C ≤ 0,05-S+P ≤ 0,02 total others ≤ 0,1
Special copper-nickel 70/30 (2)	remainder	Sn+Pb ≤ 0,05		29/32	≤ 0,02	1,5/2,0	≤ 0,5	1,5/2,0		C ≤ 0,05-S+P ≤ 0,02 total others ≤ 0,1
Copper-Alu 6	≥ 93,0	0,15/0,5	5,0/6,5		≤ 0,02	≤ 1,0	≤ 0,3			total impurities ≤ 0,5

(1) Silver is considered as copper; cobalt as nickel.
(2) When no welding is to be done on copper-nickel pipes, there are no requirements regarding P, S and C, and the Zn content may be up to 1%, the Pb content up to 0,05%.

Table 4 : Pipes - Mechanical properties

Name of Alloy	R _m (N/mm ²)	R _{e0,2} (N/mm ²)	A (%) on 5,65√S ₀
Copper-phosphorus (arsenical or non arsenical) (1)	≥ 220 ≥ 230 ≥ 270	≥ 100 ≥ 155 for guidance	≥ 35 (annealed) ≥ 20 (quarter-hard temper) ≥ 10 (half-hard temper)
Tin Brass	≥ 310	≥ 105	≥ 35
Aluminium Brass	≥ 345	≥ 125	≥ 35
Copper-nickel 90/10	≥ 290	≥ 105	≥ 30
Copper-nickel 70/30	≥ 360	≥ 125	≥ 30
Special copper-nickel 70/30	≥ 420	≥ 125	≥ 30
Copper-Alu 6	≥ 345	≥ 130	≥ 40

(1) In the case of copper-phosphorus, the tensile test may be replaced by the HV hardness test when this is specified in certain national standards.

3.5.5 The drift expanding test consists of expanding a section of pipe between 30 mm and 50 mm in length until the external diameter is increased by 20% (15% for halfhard pipes), at ambient temperature, by means of a tapered pin having a 45° included angle.

No cracking or rupture is to be visible to the unaided eye after completion of tests.

3.6 Stress corrosion cracking test

3.6.1 The stress corrosion test (Hg-nitrate test) is designed to reveal the presence of residual stresses which could lead to stress corrosion cracks.

The test consists of immersing for 30 minutes a 150 mm specimen in a water solution with the required Hg-nitrate concentration after proper cleaning.

The water solution is to contain 10gr of mercurous nitrate and 10 cm³ of nitric acid (specific gravity 1,41) per litre of solution. The specimen is then to be immediately washed, rinsed and inspected.

No signs of cracking are to appear within eight days following the immersion.

3.6.2 The test may be carried out in accordance with an acceptable national standard using a mercurous nitrate solution.

3.6.3 Should any specimen fail to meet the requirements of this test, then all tubes represented by that specimen are to be rejected but may be resubmitted after a stress relieving treatment.

3.7 Hydrostatic test - Eddy current test

3.7.1 All pipes are to be tested to a pressure equal to 1,5 times their design service pressure without exceeding 6,90 MPa, unless otherwise specified.

3.7.2 If the service pressure is unknown at the time of the hydrostatic test, a test pressure calculated according to the following formula may be applied :

$$P = \frac{0,5 \cdot t \cdot R_m}{D}$$

P : Test pressure, in MPa

t : Nominal wall thickness, in mm

D : Nominal outside diameter, in mm

R_m : Minimum guaranteed tensile strength, in N/mm², according to Tab 4.

3.7.3 The test pressure is to be maintained for sufficient time to permit proof and inspection. There is to be no evidence of leakage or sweating.

3.7.4 An Eddy current test may be accepted in lieu of the hydrostatic test.

3.7.5 The Eddy current testing facilities are to be submitted to special approval with particular attention to the calibrating conditions of the equipment used; it is to be demonstrated that testing with Eddy currents as proposed is at least as rigorous as the hydrostatic test.

3.7.6 The Surveyor may need to check that the equipment used is calibrated.

3.7.7 Unless otherwise agreed, the Manufacturer's certificate of satisfactory hydraulic or Eddy current testing will be accepted.

3.8 Visual and non-destructive examination

3.8.1 The Manufacturer is to prepare a report relative to the inspection and verification of dimensions of all of the tubes presented.

The dimensional tolerances (diameter, thickness) are to comply with applicable national standards.

3.8.2 The Surveyor may require that all pipes are presented for visual examination and verification of dimensions.

Internal and external surfaces of pipes are to have a clean and smooth finish, and be free from harmful defects.

The Manufacturer is to provide adequate equipment to enable an internal and external examination of the pipes to be carried out

3.9 Rectification of defects

3.9.1 Small surface imperfections may be removed by grinding provided that the thickness of the pipe after grinding and dressing is not less than the required minimum thickness. The dressed areas are to be blended into the contour of the tube with very large radius fillets.

3.9.2 Repair of defects by welding is not permitted; thus any defects which cannot be removed by grinding will necessarily lead to the rejection of the pipe.

3.10 Identification and marking

3.10.1 All pipes and tubes are to be identified and marked in conformity with the requirements of Ch 1, Sec 1, [4.1.3]. The following additional details are to be shown on all materials which have been accepted:

- a) Manufacturer's name or trade mark
- b) grade of material or designation code.

3.10.2 Identification is to be by rubber stamp or stencils. Hard stamping is not permitted.

SECTION 2

ALUMINIUM ALLOYS

1 General

1.1 Application

1.1.1 General

The requirements of this Section apply to wrought aluminium alloys, rivets, transition joints and cast aluminium alloys.

1.1.2 Other standards

Alloys and tempers other than those defined in Articles [2], [3], [4] and [5], and which comply with national or international standards or proprietary specifications deemed equivalent to these requirements, may be accepted with the agreement of the Society.

1.1.3 Weldability

Except for rivets, aluminium products in accordance with these Rules are weldable using suitable welding processes and, where appropriate, subject to any conditions stated at the time of approval.

1.2 Manufacture

1.2.1 Manufacturing process

Manufacturing processes and heat treatments suitable to obtain products having the specified quality and properties are, in principle, left to the discretion of the Manufacturer.

Heat treatment is to be carried out in suitable furnaces fitted with the necessary equipment, in accordance with appropriate procedures, to the satisfaction of the Surveyor.

1.2.2 Approval

The manufacturing and treatment processes and the control systems are to be approved by the Society for individual Manufacturers. To this end, detailed information is to be submitted to the Society and, as a rule, checks and tests are required depending on the importance of the product and its intended use.

1.2.3 Quality of material

All products are to have a workmanlike finish and be free from defects, surface or internal imperfections, segregation and non-metallic inclusions which may impair their proper workability and use.

1.2.4 Identification

The Manufacturer is to adopt a system of identification which will ensure that all finished material in a batch presented for testing is of the same nominal chemical composition.

1.2.5 Marking

Products are to be clearly marked by the Manufacturer in accordance with the requirements of Chapter 1.

The following details are to be shown on all materials which have been accepted:

- Manufacturer's mark
- grade of alloy and temper conditions
- number of the manufacturing batch enabling the manufacturing process to be traced
- Classification Society's brand.

When extruded products are bundled together or packed in crates for delivery, the marking is to be affixed by a securely fastened tag or label.

1.2.6 Certification and documentation (1/1/2013)

Each test certificate or shipping statement is to include the following particulars:

- purchaser's name and order number
- description and dimensions
- specification or grade of alloy
- details of heat treatment, where applicable
- identification mark which will enable the full history of the item to be traced
- chemical composition
- mechanical test results (not required on shipping statement)
- corrosion test results (if any).

Where the alloy is not produced at the works at which it is wrought, a certificate is to be supplied by the Manufacturer of the alloy stating the cast number and chemical composition. The works at which the alloy was produced is to be approved by the Society.

2 Wrought aluminium alloy products (plates, bars, sections and tubes)

2.1 Application

2.1.1 The requirements of this Article apply to wrought aluminium alloys used in the construction of hulls and other marine structures, and for cryogenic applications.

2.1.2 These requirements are applicable to wrought aluminium products within a thickness range between 3 mm and 50 mm inclusive.

2.1.3 The application of these provisions to aluminium alloy products outside this thickness range requires the prior agreement of the Society.

The general requirements specified in Article [1] are also to be complied with, as appropriate.

2.1.4 In the case of ships carrying liquefied gas in bulk, the International Code for the Construction and Equipment of Ships Carrying Liquefied Gases in Bulk also applies.

Materials intended for the construction of cargo tanks or storage tanks for liquefied gases and for other low temperature applications are to be manufactured in 5083 alloy in the annealed condition.

2.2 Aluminium grades

2.2.1 Designation (1/1/2023)

The numerical designation (grade) of aluminium alloys and their temper designation are in accordance with the "Registration Record of International Alloy Designation".

Temper conditions (delivery heat treatment) are defined in EN 515:2017 or ANSI H35.1:2017.

2.2.2 Rolled products (sheets, strips and plates) (1/7/2005)

The following aluminium alloys are covered by these requirements:

- 5083
- 5059
- 5086
- 5383
- 5456
- 5754

with the following temper conditions:

- O, H111, H112
- H116
- H321

2.2.3 Extruded products (sections, shapes, bars and closed profiles) (1/7/2005)

The following aluminium alloys are covered by these requirements:

- 5083
- 5059
- 5086
- 5383

with the following temper conditions:

- O, H111, H112

and

- 6005A
- 6061
- 6082

with the following temper conditions:

- T5 or T6

The alloy grades 6005A and 6061 of the 6000 series are not to be used in direct contact with sea water unless protected by anodes and/or a paint system.

2.3 Manufacture

2.3.1 Approval

All materials, including semi-finished products, are to be manufactured at works which are approved by the Society for the grades of aluminium alloy supplied ([1.2.2]).

Plates are to be formed by rolling and may be hot or cold finished.

Bars and sections may be formed by extrusion, rolling or drawing.

2.3.2 Quality of materials

It is the producer's responsibility to check the quality of the materials as well as conformity with dimensional tolerances.

2.3.3 Repairs

Slight surface imperfections may be removed by grinding or machining provided the thickness of the material remains everywhere within acceptable tolerances.

The repair of defects by welding is not accepted.

2.3.4 Dimensional tolerances (1/7/2005)

The under thickness tolerances for rolled products given in Tab 1 are minimum requirements.

The underthickness tolerances for extruded products are to be in accordance with the requirements of recognised international or national standards.

Dimensional tolerances other than under thickness tolerances are to comply with a recognised national or international standard.

2.3.5 Non-destructive examination

In general, the non-destructive examination of material is not required for acceptance purposes.

Table 1 : Under thickness tolerances for rolled products

Nominal thickness (mm)	Thickness tolerances for nominal width (mm)		
	up to 1500	from 1500 to 2000	from 2000 to 3500
from 3 to 4	0,10	0,15	0,15
from 4 to 8	0,20	0,20	0,25
from 8 to 12	0,25	0,25	0,25
from 12 to 20	0,35	0,40	0,50
from 20 to 50	0,45	0,50	0,65

2.4 Chemical composition

2.4.1 The Manufacturer is to determine the chemical composition of each cast.

2.4.2 (1/7/2005)

The chemical composition of aluminium alloys is to comply with the requirements given in Tab 2.

The Manufacturer's declared analysis is accepted subject to occasional checking if required by the Surveyor; in particular, product analysis may be required where the final product chemistry is not well represented by the analysis from the cast.

2.4.3 When the aluminium alloys are not cast in the same works in which they are manufactured into semi-finished products, the Surveyor is to be given a certificate issued by the works in question indicating the reference numbers and chemical composition of the heats.

2.5 Corrosion testing

2.5.1 (1/7/2015)

Rolled 5xxx-alloys of type 5083, 5383, 5059, 5086 and 5456 in the H116 and H321 tempers intended for use in marine hull construction or in marine applications where frequent direct contact with seawater is expected are to be corrosion tested with respect to exfoliation and intergranular corrosion resistance.

2.5.2 (1/1/2023)

The Manufacturers are to establish the relationship between microstructure and resistance to corrosion when the alloys as per [2.5.1] are approved. A reference photomicrograph taken at 500x, under the conditions specified in ASTM B928:2015, Section 9.4.1, is to be established for each of the alloy-tempers and thickness ranges relevant. The reference photographs are to be taken from samples which have exhibited no evidence of exfoliation corrosion and a pitting rating of PB or better, when subjected to the test described in ASTM G66:2018 (ASSET). The samples are also to have exhibited resistance to intergranular corrosion at a mass loss no greater than 15mg/cm², when subjected to the test described in ASTM G67:2018 (NAMLT). Upon satisfactory establishment of the relationship between microstructure and resistance to corrosion, the master photomicrographs and the results of the corrosion tests are to be approved by the Society. Production practices are not to be changed after approval of the reference micrographs.

Other test methods may also be accepted at the discretion of the Society.

2.5.3 (1/1/2023)

For batch acceptance of 5xxx-alloys in the H116 and H321 tempers, metallographic examination of one sample selected from mid width at one end of a coil or random sheet or plate is to be carried out. The microstructure of the sample is to be compared to the reference photomicrograph of acceptable material in the presence of the Surveyor. A longitudinal section perpendicular to the rolled surface is to

be prepared for metallographic examination, under the conditions specified in ASTM B928:2015, Section 9.6.1.

If the microstructure shows evidence of continuous grain boundary network of aluminium-magnesium precipitate in excess of the reference photomicrographs of acceptable material, the batch is either to be rejected or tested for exfoliation-corrosion resistance and intergranular corrosion resistance subject to the agreement of the Surveyor. The corrosion tests are to be in accordance with ASTM G66:2018 and G67:2018 or equivalent standards. Acceptance criteria are that the sample shall exhibit no evidence of exfoliation corrosion and a pitting rating of PB or better when test subjected to ASTM G66:2018 ASSET test, and the sample shall exhibit resistance to intergranular corrosion at a mass loss no greater than 15mg/cm² when subjected to ASTM G67:2018 NAMLT test.

If the results from testing satisfy the acceptance criteria stated in [2.5.2] the batch is accepted, otherwise, it is to be rejected.

As an alternative to metallographic examination, each batch may be tested for exfoliation corrosion resistance and intergranular corrosion resistance, in accordance with ASTM G66:2018 and G67:2018 under the conditions specified in ASTM B928:2015, or equivalent standards. If this alternative is used, then the results of the test must satisfy the acceptance criteria stated in this item [2.5.3].

2.5.4 (1/7/2005)

Tempers that are corrosion tested are to be marked "M" after the temper condition, e.g. 5083 H321M.

2.6 Mechanical properties

2.6.1 (1/7/2005)

Mechanical properties are specified in Tab 3 and Tab 4.

2.7 Mechanical tests

2.7.1 General (1/7/2005)

Test specimens for mechanical tests and procedures are to be selected in accordance with Chapter 1 or national or international requirements relative to the wrought aluminium alloy materials concerned.

The Manufacturer is to demonstrate by macro-section tests or drift expansion tests of closed profiles performed on each batch of closed profiles that there is no lack of fusion at the press welds.

Once cut and machined, test materials are not to be submitted to any heat or mechanical treatment.

2.7.2 Batch composition

Each batch is made of products:

- of the same alloy grade and from the same cast
- of the same product form and of similar dimensions (for plates: same thickness)
- manufactured by the same process
- having been submitted simultaneously to the same temper condition.

2.7.3 Sampling (1/7/2005)

Tests samples are to be taken:

- a) at one third of the width from a longitudinal edge of rolled products
- b) in the range from 1/3 to 1/2 of the distance from the edge to the centre of the thickest part of extruded products.

Test samples are to be taken so that the orientation of test specimens is as follows:

1) Rolled products (plates, sheets)

Normally, tests in the transverse direction are required. If the width is insufficient to obtain transverse test speci-

mens, or in the case of strain hardening alloys, tests in the longitudinal direction may be permitted.

2) Extruded products

Extruded products or extruded drawn materials (pipes, bars, miscellaneous sections) are tested in the longitudinal direction.

After removal of test samples, each test specimen is to be marked so that its original identity, location and orientation are maintained.

Table 2 : Chemical composition (1/7/2005)

Grade	Chemical composition (%) (1)									Other elements (2)	
	Si	Fe	Cu	Mn	Mg	Cr	Zn	Ti	Each	Total	
	5083	0,40	0,40	0,10	0,40-1,0	4,0-4,9	0,05-0,25	0,25	0,15	0,05	0,15
5383	0,25	0,25	0,20	0,7-1,0	4,0-5,2	0,25	0,40	0,15	0,05 (5)	0,15 (5)	
5059	0,45	0,50	0,25	0,6-1,2	5,0-6,0	0,25	0,40-0,90	0,20	0,05 (6)	0,15 (6)	
5086	0,40	0,50	0,10	0,20-0,7	3,5-4,5	0,05-0,25	0,25	0,15	0,05	0,15	
5754	0,40	0,40	0,10	0,50 (3)	2,6-3,6	0,30 (3)	0,20	0,15	0,05	0,15	
5456	0,25	0,40	0,10	0,50-1,0	4,7-5,5	0,05-0,20	0,25	0,20	0,05	0,15	
6005A	0,50-0,9	0,35	0,30	0,50 (4)	0,40-0,7	0,30 (4)	0,20	0,10	0,05	0,15	
6061	0,40-0,8	0,7	0,15-0,40	0,15	0,8-1,2	0,04-0,35	0,25	0,15	0,05	0,15	
6082	0,7-1,3	0,50	0,10	0,40-1,0	0,6-1,2	0,25	0,20	0,10	0,05	0,15	

(1) Chemical composition in percentage mass by mass maximum unless shown as a range or as a minimum.
(2) Includes Ni, Ga, V and listed elements for which no specific limit is shown. Regular analysis need not be made.
(3) Mn + Cr: 0,10-0,60
(4) Mn + Cr: 0,12-0,50
(5) Zr: maximum 0,20. The total for other elements does not include Zirconium.
(6) Zr: 0,05-0,25. The total for other elements does not include Zirconium.

Table 3 : Mechanical properties for rolled products, 3 mm ≤ t ≤ 50 mm (1/1/2013)

Grade	Temper condition (3)	Thickness, t	Yield Strength $R_{p0.2}$ min. or range (N/mm ²)	Tensile Strength R_m min or range (N/mm ²)	Elongation, % min. (1)	
					A ₅₀ mm	A _{5d}
5083	O	3 ≤ t ≤ 50 mm	125	275-350	16	14
	H111	3 ≤ t ≤ 50 mm	125	275 - 350	16	14
	H112	3 ≤ t ≤ 50 mm	125	275	12	10
	H116	3 ≤ t ≤ 50 mm	215	305	10	10
	H321	3 ≤ t ≤ 50 mm	215 - 295	305 - 385	12	10
5383	O	3 ≤ t ≤ 50 mm	145	290		17
	H111	3 ≤ t ≤ 50 mm	145	290		17
	H116	3 ≤ t ≤ 50 mm	220	305	10	10
	H321	3 ≤ t ≤ 50 mm	220	305	10	10
5059	O	3 ≤ t ≤ 50 mm	160	330		24
	H111	3 ≤ t ≤ 50 mm	160	330		24
	H116	3 ≤ t ≤ 20 mm	270	370	10	10
		20 ≤ t ≤ 50 mm	260	360	10	10
	H321	3 ≤ t ≤ 20 mm	270	370	10	10
		20 ≤ t ≤ 50 mm	260	360	10	10
5086	O	3 ≤ t ≤ 50 mm	95	240-305	16	14
	H111	3 ≤ t ≤ 50 mm	95	240 - 305	16	14
	H112	3 ≤ t ≤ 12,5 mm	125	250	8	
		12,5 ≤ t ≤ 50 mm	105	240		9
	H116	3 ≤ t ≤ 50 mm	195	275	10 (2)	9
5754	O	3 ≤ t ≤ 50 mm	80	190-240	18	17
	H111	3 ≤ t ≤ 50 mm	80	190-240	18	17
5456	O	3 ≤ t ≤ 6,3 mm	130 - 205	290 - 365	16	
		6,3 ≤ t ≤ 50 mm	125 - 205	285 - 360	16	14
	H116	3 ≤ t ≤ 30 mm	230	315	10	10
		30 ≤ t ≤ 40 mm	215	305		10
		40 ≤ t ≤ 50 mm	200	285		10
	H321	3 ≤ t ≤ 12,5 mm	230 - 315	315 - 405	12	
		12,5 ≤ t ≤ 40 mm	215 - 305	305 - 385		10
		40 ≤ t ≤ 50 mm	200 - 295	285 - 370		10

(1) Elongation in 50 mm applies for thicknesses up to and including 12,5 mm and in 5d for thicknesses over 12,5 mm.
(2) 8 % for thicknesses up to and including 6,3 mm.
(3) The mechanical properties for the O and H111 tempers are the same. However, they are separated to discourage dual certification as these tempers represent different processing.

2.7.4 Type and location of tensile test specimen

A flat tensile test specimen is to be used for specified thicknesses up to and including 12,5mm.

The tensile test specimen is to be prepared so that both rolled surfaces are maintained.

For thicknesses exceeding 12,5mm, a round tensile test specimen is to be used.

For thicknesses up to and including 40mm, the longitudinal axis of the round tensile test specimen is to be located at a distance from the surface equal to half of the thickness.

For thicknesses over 40mm, the longitudinal axis of the round tensile test specimen is to be located at a distance from one of the surfaces equal to one quarter of the thickness.

For pipes equal to or less than 40mm in diameter: the test specimen consists of a section of the tube itself.

For pipes more than 40mm in diameter: the test specimen consists of a part of the tube sectional area only.

Table 4 : Mechanical properties for extruded products, $3 \text{ mm} \leq t \leq 50 \text{ mm}$ (1/7/2007)

Grade	Temper condition	Thickness, t	Yield Strength $R_{p0,2}$ min. or range (N/mm ²)	Tensile Strength R_m min or range (N/mm ²)	Elongation, % min. (1) (2)	
					A_{50} mm	A_{5d}
5083	0	$3 \leq t \leq 50 \text{ mm}$	110	270 - 350	14	12
	H111	$3 \leq t \leq 50 \text{ mm}$	165	275	12	10
	H112	$3 \leq t \leq 50 \text{ mm}$	125	270	12	10
5383	0	$3 \leq t \leq 50 \text{ mm}$	145	290	17	17
	H111	$3 \leq t \leq 50 \text{ mm}$	145	290	17	17
	H112	$3 \leq t \leq 50 \text{ mm}$	190	310		13
5059	H112	$3 \leq t \leq 50 \text{ mm}$	200	330		10
5086	0	$3 \leq t \leq 50 \text{ mm}$	95	240 - 320	18	15
	H111	$3 \leq t \leq 50 \text{ mm}$	145	250	12	10
	H112	$3 \leq t \leq 50 \text{ mm}$	95	240	12	10
6005A	T5	$3 \leq t \leq 50 \text{ mm}$	215	260	9	8
	T6	$3 \leq t \leq 10 \text{ mm}$	215	260	8	6
		$10 < t \leq 50 \text{ mm}$	200	260	8	6
6061	T6	$3 \leq t \leq 50 \text{ mm}$	240	260	10	8
6082	T5	$3 \leq t \leq 50 \text{ mm}$	230	270	8	6
	T6	$3 \leq t \leq 5 \text{ mm}$	250	290	8	
		$5 < t \leq 50 \text{ mm}$	260	310	10	8

(1) The values are also applicable for longitudinal and transverse tensile test specimens.

(2) Elongation in 50 mm applies for thicknesses up to and including 12,5 mm and in 5d for thicknesses over 12,5 mm.

2.8 Testing

2.8.1 Tensile test

a) Rolled products

One tensile test specimen is to be taken from each batch of the product. If the weight of one batch exceeds 2000 kg, one extra tensile test specimen is to be taken from every 2000 kg of the product or fraction thereof, in each batch.

For single plates or for coils weighing more than 2000kg each, one tensile test specimen per plate or coil only is to be taken.

For plates to be used in the construction of cargo tanks, secondary barriers and process pressure vessels with design temperatures below -55°C, a tensile test is required from each plate.

b) Extruded products

For products with a nominal weight of less than 1kg/m, one tensile test specimen is to be taken from each 1000 kg, or fraction thereof, in each batch. For nominal weights between 1 and 5 kg/m, one tensile test is to be taken from each 2000 kg or fraction thereof, in each batch. If the nominal weight exceeds 5kg/m, one tensile test specimen is to be taken for each 3000 kg of the product or fraction thereof, in each batch.

For pipes, one test sample from each batch is to be taken.

Batches are to be made up of no more than 50 tubes of the same diameter and wall thickness, manufactured from the same cast with the same final condition or heat treatment.

At the discretion of the Surveyor, tubes having slightly different diameters and/or thicknesses may be included in the same batch.

2.8.2 Verification of proper fusion of press welds

For press welded closed profiles, verification of proper fusion of press welds by macro section or drift expansion tests is to be performed on each batch.

2.8.3 Drift expansion tests (1/7/2005)

- a) Every fifth profile is to be sampled after final heat treatment. For batches of five profiles or less, one profile is to be sampled. Profiles with lengths exceeding 6 m are to be sampled every profile at the start of the production. The number of tests may be reduced to every fifth profile if the results from the first 3-5 profiles are found to be acceptable.
- b) Each profile sampled is to have two samples cut from the front and back end of the production profile.
- c) The test specimens are to be cut with the ends perpendicular to the axis of the profile. The edges of the end may be rounded by filing.
- d) The length of the specimen is to be in accordance with Ch 1, Sec 2, [7.2].
- e) Testing is to be carried out at ambient temperature and is to consist of expanding the end of the profile by

means of a hardened conical steel mandrel having an included angle of at least 60°.

- f) The sample is considered to be unacceptable if it fails with a clean split along the weld line which confirms lack of fusion.

2.8.4 Corrosion tests (1/7/2005)

For rolled plates of grade 5083, 5383, 5059, 5086 and 5456 delivered in the tempers H116 or H321, one sample is to be tested per batch.

2.9 Re-test procedures

2.9.1 When the tensile test from the first piece selected in accordance with [2.8.1] fails to meet the requirements, two further tensile tests may be made from the same piece. If both of these additional tests are satisfactory, this piece and the remaining pieces from the same batch may be accepted.

2.9.2 If one or both of the additional tests referred to in [2.9.1] is/are unsatisfactory, the piece is to be rejected, but the remaining material from the same batch may be accepted, provided that two of the remaining pieces in the batch selected in the same way are tested with satisfactory results.

If unsatisfactory results are obtained from either of these two pieces, then the batch of material is rejected.

2.9.3 In the event of any material bearing the Society's brand failing to comply with the test requirements, the brand is to be unmistakably defaced by the Manufacturer.

2.10 Hydrostatic test

2.10.1 Pipes intended for pressure parts are to be subjected to hydrostatic testing.

Unless otherwise required, the test pressure is to be at least 1,5 times the maximum working pressure.

2.11 Visual and non-destructive examination

2.11.1 Surface inspection and verification of dimensions are the responsibility of the Manufacturer.

Unless otherwise agreed, the following products are to be submitted to the Surveyor for visual examination:

- plates for the construction of cargo tanks, secondary barriers and process pressure vessels
- pressure pipes.

2.11.2 In general non-destructive tests of materials are not required for acceptance purposes. However, such tests may be required for specific applications, or by the Surveyor as an additional check.

3 Rivets

3.1 Application

3.1.1 Generality

The requirements of this Article apply to aluminium alloy rivets intended for use in the construction of marine structures.

3.2 Chemical composition and heat treatment

3.2.1 For rivets or rivet bars which are made up of magnesium alloys, the magnesium content is not to exceed a maximum of 3,9%.

In particular, the chemical composition of bars used for the manufacture of rivets is to comply with the requirements of Tab 5.

Table 5 : Chemical composition, percentage

Element	5154A	6082
Copper	0,10 max	0,10 max
Magnesium	3,10 - 3,90	0,60 - 1,20
Silicon	0,50 max	0,70 - 1,30
Iron	0,50 max	0,50 max
Manganese	0,10 - 0,50	0,40 - 1,00
Zinc	0,20 max	0,20 max
Chromium	0,25 max	0,25 max
Titanium	0,20 max	0,10 max
Other elements: each	0,05 max	0,05 max
total	0,15 max	0,15 max
Aluminium	remainder	remainder

3.3 Heat treatment

3.3.1 Rivets are to be supplied in the following conditions:

5154A - annealed

6082 - solution treated.

3.4 Test material

3.4.1 Bars intended for the manufacture of rivets are to be presented for testing in batches of no more than 250 kg.

The material in each batch is to be of the same alloy, manufacturing process and final heat treatment and have the same or a comparable diameter. One test sample is to be taken from each batch and, prior to testing, heat treated in full cross-section and in a manner simulating the heat treatment applied to the finished rivets.

3.5 Mechanical tests

3.5.1 At least one tensile specimen and one flattening test specimen are to be prepared from each test sample.

3.5.2 The tensile test specimen is to be a short length of bar having the original diameter of the product.

3.5.3 The flattening test consists of compressing the specimen between two rigid and parallel flat plates in a direction perpendicular to its longitudinal axis; the plates are to cover the whole specimen after flattening.

The flattening test specimen is to consist of a full section of bar having the original diameter of the product and a length of 1,5 times the diameter cut from the bar.

The test is to be continued until the distance between the two plates, measured under load, reaches a value corresponding to one half of the original length of the specimen.

The test is to be performed at ambient temperature.

The result of the test is satisfactory if, after compression, the specimen is free from cracks.

3.5.4 The results of tensile tests are to comply with the appropriate requirements of Tab 6.

Table 6 : Mechanical properties

Mechanical properties	5154A	6082
0,2% proof stress (N/mm ²) min	90	120
Tensile strength (N/mm ²) min	220	190
Elongation (%) on 5, 65 $\sqrt{S_0}$ min	18	16

3.5.5 At least three samples are to be selected from each consignment of manufactured rivets. Flattening tests as detailed in [3.5.3] are to be carried out on each sample.

3.6 Identification

3.6.1 Each package of manufactured rivets is to be identified with attached labels giving the following details:

- Manufacturer's name or trade mark
- alloy grade
- rivet size.

3.7 Certification

3.7.1 The test certificate for each consignment of manufactured rivets is to include the following particulars:

- purchaser's name and order number
- description and dimensions
- specification of the alloy.

4 Transition joints

4.1 General

4.1.1 The requirements of this Article apply to explosion bonded composite aluminium/steel transition joints used for the connection of aluminium structures to steel plating.

4.2 Manufacture

4.2.1 Transition joints are to be manufactured at works which are approved by the Society. The specification of the Manufacturer is to be submitted for approval. The maximum temperature allowable at the interface during welding is to be indicated; approval tests are required.

4.2.2 The aluminium material is to comply with the requirements of [2] and the steel is to be of an appropriate grade complying with the requirements of Ch 2, Sec 1.

4.3 Visual and non-destructive examination

4.3.1 Each composite plate is to be subjected to 100% visual and ultrasonic examination in accordance with a relevant national standard to determine the extent of any unbonded areas. The latter are unacceptable and any such area plus 25 mm of surrounding sound material is to be discarded.

4.4 Inspection

4.4.1 The series of tests includes, from each end of one plate in a batch of three plates:

- one through thickness tensile test
- one shear test
- one bend test.

4.4.2 Tests are made on specimens equivalent to those specified at the approval.

The results of these tests are to comply with the requirements of the manufacturing specification.

5 Aluminium alloy castings

5.1 General

5.1.1 The requirements of this Article apply to aluminium alloy castings used in the construction of hulls and other marine structures, and for cryogenic applications where the design temperature is not lower than -165°C .

5.2 Aluminium grades

5.2.1 Alloy castings may be manufactured with magnesium, silicon or magnesium-silicon alloys as follows:

- a) magnesium alloys: Al-Mg 3 and Al-Mg 6
- b) silicon alloys: Al-Si 12
- c) magnesium-silicon alloys: Al-Si 7 Mg 0,3; Al-Si 7 Mg 0,6; Al-Si 10 Mg; and possibly: Al-Si 2 Mg.

5.2.2 Alloys Al-Mg 3, Al-Mg 6 and Al-Si 12 are not generally submitted to heat treatment after casting; this is not the case for magnesium-silicon alloys which may undergo such treatment.

5.2.3 The use of other alloys or of alloys which have been submitted to a specific heat treatment is subject to the Society's agreement.

5.3 Manufacture

5.3.1 Approval

Alloy castings are to be manufactured at works which are approved by the Society for the grade of aluminium alloy supplied.

5.3.2 Quality of castings

All castings are to be free from surface or internal defects which would be prejudicial to their proper application in service.

5.3.3 Visual examination

All castings are to be cleaned and adequately prepared for inspection.

The visual examination and verification of dimensions are the responsibility of the Manufacturer, unless otherwise agreed.

Before acceptance, all castings are to be presented to the Surveyor for visual examination, unless otherwise agreed with him.

5.3.4 Non-destructive tests

If non-destructive tests are required, the procedures are to be examined by the Society.

5.3.5 Repairs

At the discretion of the Surveyor, small surface defects may be removed by grinding.

Where repairs by welding are necessary, the welding procedure is to be preliminarily approved by the Society, which will state the tests and checks deemed necessary.

The agreed repairs are then to be surveyed as required.

5.3.6 Pressure testing

Where required by the relevant construction Rules, casting are to be pressure tested before final acceptance.

Unless otherwise agreed, these tests are to be carried out in the presence and to the satisfaction of the Surveyor.

5.4 Chemical composition

5.4.1 The chemical composition of aluminium alloys used to manufacture castings is given in Tab 7 and the relevant certificate is to be provided by the producer.

5.5 Mechanical properties

5.5.1 The mechanical properties are given in Tab 8.

5.5.2 The mechanical properties given in Tab 8 correspond to the non-heat treated condition. However, the test pieces may be heat-treated.

In the case of heat treatment, test samples are to be treated in the same way and, as a rule, together with the material they represent.

Generally, only tensile strength and elongation values are rule requirements; the values of yield stress are given for information.

5.6 Mechanical tests

5.6.1 At least one tensile specimen is to be tested from each batch.

Batches are to have a total mass not exceeding 500kg and be made up of pieces having the same or comparable shape and dimensions, manufactured from the same cast with the same condition of heat treatment.

The number of pieces in each batch is not to exceed 25 in the case of castings for pistons and for pressure parts or

pieces of considerable importance; a greater number may be accepted for small pieces, to the Surveyor's satisfaction.

The homogeneity of batches of aluminium alloy castings may be checked by means of a Brinell type hardness test when small castings manufactured in large quantities are concerned.

5.6.2 The test samples are to be separately cast in moulds made from the same type of material as used for the castings. These moulds are to conform to national standards, as appropriate.

5.6.3 The method and procedures for the identification of the test specimens, and the casting they represent, are to be agreed with the Surveyor. The identification marks are to be maintained during the preparation of test specimens.

5.6.4 Where the results of a test do not comply with the requirements, the re-test procedure detailed in Chapter 1 is to be applied. When castings are to be used in the heat treated condition, the re-test sample is also to be heat treated together with the castings it represents.

Table 7 : Aluminium alloy castings - Chemical composition (see Note 1)

Designation ISO		Si (%)	Fe (%)	Cu (%)	Mn (%)	Mg (%)	Ni (%)	Zn (%)	Pb (%)	Sn (%)	Ti (%)	Others (%)		
												each	total	
Al-Mg 3	Mini	0,50	0,50	0,10	0,50	2,50	0,05	0,20	0,05	0,05	0,05	0,05	0,05	0,15
	Maxi					3,50					0,25			
Al-Mg 6 (1)	Mini	0,40	0,50	0,10	0,50	5,00	0,05	0,20	0,05	0,05	0,20	0,05	0,15	
	Maxi					7,00								
Al-Si 2 Mg	Mini	1,60	0,60	0,10	0,30	0,45	0,05	0,10	0,05	0,05	0,05	0,05	0,15	
	Maxi	2,40			0,50	0,65					0,20			
Al-Si 7 Mg (2)	Mini	6,50	0,55	0,15	0,50	0,20	0,05	0,10	0,05	0,05	0,05	0,05	0,15	
	Maxi	7,50				0,40					0,25			
Al Si 7 Mg 0,3 (2)	Mini	6,50	0,20	0,10	0,10	0,25	0,05	0,10	0,05	0,05	0,08	0,03	0,10	
	Maxi	7,50				0,40					0,25			
Al Si 7 Mg 0,6 (2)	Mini	6,50	0,20	0,10	0,10	0,45	0,05	0,10	0,05	0,05	0,08	0,03	0,10	
	Maxi	7,50				0,70					0,25			
Al Si 10 Mg (2)	Mini	9,00	0,60	0,10	0,50	0,17	0,05	0,10	0,05	0,05	0,20	0,05	0,15	
	Maxi	11,00				0,40								
Al Si 12 (2)	Mini	11,00	0,70	0,10	0,50	0,10	0,05	0,15	0,05	0,05	0,15	0,05	0,15	
	Maxi	13,50												

(1) This alloy may contain less than 0,04% of beryllium, which is not to be considered as an impurity.
(2) These alloys may contain elements necessary to the eutectic modification with contents of less than 0,20%, which are not to be considered as impurities.
Note 1: Small variations in the contents of some elements in comparison to the values mentioned in this Table are possible in agreement with the Society.

Table 8 : Aluminium alloy casting - Mechanical characteristics

Designation ISO (3)	Guaranteed minimum values			
	Minimum tensile strength R (N/mm ²)	Minimum yield stress R _{e0,2} (N/mm ²) (1)	Elongation A (%) on 5,65√S ₀	Brinell Hardness HB (2)
Al Mg 3-F	170	70	7,0	60
Al Mg 6-F	180	100	4,0	65
Al Si 2 Mg-F	170	70	5,0	50
Al Si 7 Mg-F	170	80	4,0	55
Al Si 7 Mg 0,3-T6	250	180	4,0	75
Al Si 7 Mg 0,6-T6	290	210	4,0	90
Al Si 10 Mg-F	170	90	4,0	55
Al Si 10 Mg-T6	250	180	1,5	80
Al Si 12-F	170	75	5,0	55

(1) For information only.
(2) Minimum hardness which can be specified for heat treated elements.
(3) F = as cast.
T6 = quenched and tempered.

Part D
Materials and Welding

Chapter 4

MISCELLANEOUS EQUIPMENT

SECTION 1 EQUIPMENT

SECTION 2 VARIOUS FINISHED PRODUCTS

SECTION 1 EQUIPMENT

1 Anchors

1.1 Application

1.1.1 General

The requirements of this Article apply to anchors and associated components (heads, shanks and shackles) made of cast or forged steel, or fabricated by welding from rolled steel.

1.1.2 Modified testing procedure for anchors of small mass

For anchors having mass lower than 100 kg, or 75 kg in the case of high holding power anchors, continuously produced by Manufacturers who have been approved by the Society for this purpose, a batch testing procedure is admitted, with random execution of the checks required for normal testing.

The composition of the batches is to be judged appropriate as regards the homogeneity of material, manufacturing, heat treatment and dimensions.

1.2 Design - Manufacture

1.2.1 General (1/2/2007)

Anchors are to be manufactured by recognised Manufacturers, according to approved plans or recognised standards; see Pt B, Ch 10, Sec 4, [3.2].

For approval and/or acceptance of high holding power (HHP) and super high holding power (SHHP) anchors, the type tests indicated in Pt B, Ch 10, Sec 4, [3.2] are to be carried out.

Steel forgings and castings for anchors is to comply with the applicable requirements of Ch 2, Sec 3 and Ch 2, Sec 4, respectively, and are to be manufactured by recognised Manufacturers.

1.2.2 Tolerances (1/1/2007)

If not otherwise specified on standards or on drawings demonstrated to be appropriate, the following assembly and fitting tolerances are to be applied.

The clearance either side of the shank within the shackle jaws is to be in accordance with Tab 1 depending on the anchor mass.

The shackle pin is to be a push fit in the eyes of the shackle, which are to be chamfered on the outside to ensure a good tightness when the pin is clenched over on fitting.

The shackle pin to hole tolerance is to be no more than 0,5mm for pins up to 57mm and 1,0 mm for pins of larger diameter.

The trunnion pin is to be a snug fit within the chamber and be long enough to prevent horizontal movement. The gap is to be no more than 1% of the chamber length.

The lateral movement of the shank is not to exceed 3 degrees (see Fig 1).

Table 1 (1/1/2007)

Anchor mass (t)	Clearance (mm)
Up to 3	3
Over 3 up to 5	4
Over 5 up to 7	6
Over 7	12

Figure 1 (1/1/2007)

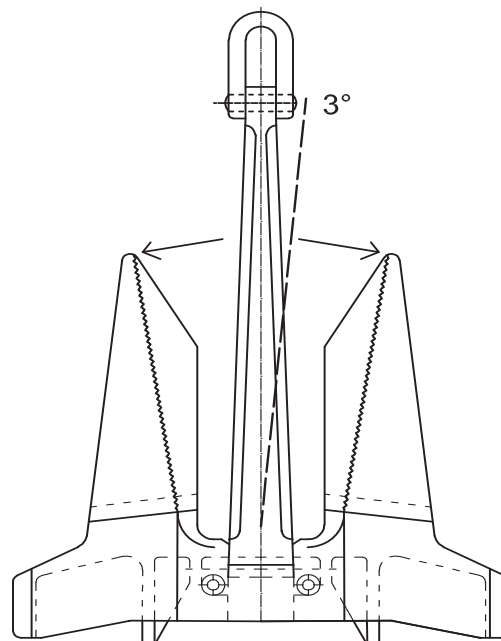

1.2.3 Welded anchors (1/1/2007)

Welded anchors are to be manufactured in accordance with approved procedures.

1.2.4 Heat treatment (1/1/2007)

Components for forged or cast anchors are to be properly heat treated in accordance with the applicable requirements of Ch 2, Sec 3 and Ch 2, Sec 4, respectively.

Fabricated anchors may require stress relief after welding depending upon weld thickness.

Stress relief is to be carried out as indicated in the approved welding procedure.

Stress relief temperatures are not to exceed the tempering temperature of the base material.

1.2.5 Quality of materials and repair of defects (1/1/2007)

Anchors are to have a clean surface consistent with the method of manufacture and be free from cracks, notches, inclusions and other defects that would impair the performance of the product.

Any necessary repairs to forged and cast anchors are to be agreed by the Surveyor and carried out in accordance with the repair criteria indicated in Ch 2, Sec 3 and Ch 2, Sec 4, respectively.

Repairs to fabricated anchors are to be agreed by the Surveyor and carried out in accordance with qualified welding procedures, by qualified welders, following the parameters of the welding procedures used in construction.

For fracture and unsoundness detected in a drop test or hammering test, repairs are not permitted and the component is to be rejected.

1.2.6 Anchor assembly (1/1/2007)

Assembly and fitting are to be done in accordance with the design details.

Securing of the anchor pin, shackle pin or swivel nut by welding is to be done in accordance with an approved procedure.

1.2.7 The mass of anchors and the percentages of the mass of components in relation to the total mass are to be as required in the various parts of the Rules relevant to the equipment.

1.3 Materials - testing

1.3.1 (1/1/2007)

Materials are to comply with the approved plans or the unified requirement or standard applied; the requirements of Ch 2, Sec 1, [2], Ch 2, Sec 3, [2] and Ch 2, Sec 4, [2] relevant to rolled, forged or cast steels are applicable as far as appropriate.

Cast steel is to be fine grained treated with aluminium.

When cast anchors are not submitted to drop and hammer tests, Charpy V-notch (CVN) impact testing of material is required (see [1.5.3]).

Forged steel for shanks, swivels and shackles is to comply with the requirements for carbon and carbon-manganese steels for welded construction.

The use of other steel grades for the manufacture of swivels may be considered.

The toughness of steel for SHHP cast anchors is to be not less than a CVN average energy 27J at 0°C.

The toughness of steel anchor shackles for SHHP anchors is to be not less than a CVN average energy of 60 J at 0°C or 35J at -20 °C.

1.3.2 The mechanical tests of the material are to be carried out in compliance with the requirements of Chapter 2.

For stockless anchors, the testing is to cover heads and shanks.

1.4 Visual and dimensional examination

1.4.1 Visual examination

Each anchor is to be submitted to visual examination in order to ascertain, in addition to the absence of imperfections of harmful nature, that surface condition is smooth and uniform. The individual pieces are to be subjected to this examination in a clean condition and without paint.

1.4.2 Check of mass and dimensions (1/1/2007)

The check is to be performed by the Manufacturer measuring the total mass, the mass of each component and the main dimensions. The Surveyor is only required to monitor this inspection. The mass of the anchor is to exclude the mass of the swivel, unless this is an integral component. The Manufacturer is to issue a certificate detailing the masses measured, to be attached to the testing documentation.

1.5 Drop test and hammering test

1.5.1 Drop test (1/1/2007)

The drop test is to be performed on cast anchors by dropping the anchor from a height of 4m in compliance with an agreed procedure, on a steel slab suitable to resist the impact of the dropped material.

1.5.2 Hammering test (1/1/2007)

After the drop test, hammering tests are carried out on each anchor fluke and shank, which is slung clear of the ground, using a non-metallic sling, and hammered to check the soundness of the component. A hammer of at least 3 kg mass is to be used.

1.5.3 Additional tests (1/1/2007)

Subject to preliminary agreement, drop and hammering tests may be omitted subject to the following conditions:

- additional non-destructive tests, as indicated in [1.6.4] and [1.6.5], and ultrasonic testing in a random area of castings are to be carried out
- additional impact tests (CVN not less than 27 J at 0°C) are to be carried out.

1.6 Proof load test

1.6.1 General (1/1/2007)

Each steel anchor, complete in all its parts, is to be subjected, in the presence of the Surveyor, to a proof loading test at the load indicated in Tab 2 depending on the mass.

This requirement may be waived for anchors having a mass of 15000 kg and over, subject to special conditions stipulated in each case.

The following mass is to be used in determining the test load:

- for stocked anchors, the mass of the anchor without the stock
- for stockless anchors, the total mass of the anchor
- for high holding power anchors, a mass equal to 1,33 times the total mass of the anchor
- for very super holding power anchors, a mass equal to twice the total mass of the anchor.

Before application of the proof test load, the anchors are to be examined to ensure that castings are reasonably free of surface imperfections of a harmful nature.

After proof load testing the anchors are to be examined as indicated in [1.6.3].

Table 2 : Proof load test (1/1/2007)

Mass (kg)	Proof load (kN)	Mass (kg)	Proof load (kN)	Mass (kg)	Proof load (kN)	Mass (kg)	Proof load (kN)	Mass (kg)	Proof load (kN)	Mass (kg)	Proof load (kN)
50	23,2	550	124	2200	376	4800	645	7800	861	17500	1390
55	25,2	600	132	2300	388	4900	653	8000	877	18000	1410
60	27,1	650	140	2400	401	5000	661	8200	892	18500	1440
65	28,9	700	149	2500	414	5100	669	8400	908	19000	1470
70	30,7	750	158	2600	427	5200	677	8600	922	19500	1490
75	32,4	800	166	2700	438	5300	685	8800	936	20000	1520
80	33,9	850	175	2800	450	5400	691	9000	949	21000	1570
90	36,3	900	182	2900	462	5500	699	9200	961	22000	1620
100	39,1	950	191	3000	474	5600	706	9400	975	23000	1670
120	44,3	1000	199	3100	484	5700	713	9600	879	24000	1720
140	49,0	1050	208	3200	495	5800	721	9800	998	25000	1770
160	53,3	1100	216	3300	506	5900	728	10000	1010	26000	1800
180	57,4	1150	224	3400	517	6000	735	10500	1040	27000	1850
200	61,3	1200	231	3500	528	6100	740	11000	1070	28000	1900
225	65,8	1250	239	3600	537	6200	747	11500	1090	29000	1940
250	70,4	1300	247	3700	547	6300	754	12000	1110	30000	1990
275	74,9	1350	255	3800	557	6400	760	12500	1130	31000	2030
300	79,5	1400	262	3900	567	6500	767	13000	1160	32000	2070
325	84,1	1450	270	4000	577	6600	773	13500	1180	34000	2150
350	88,8	1500	278	4100	586	6700	779	14000	1210	36000	2250
375	93,4	1600	292	4200	595	6800	786	14500	1230	38000	2330
400	97,9	1700	307	4300	604	6900	794	15000	1260	40000	2410
425	103	1800	321	4400	613	7000	804	15500	1270	42000	2490
450	107	1900	335	4500	622	7200	818	16000	1300	44000	2570
475	112	2000	349	4600	631	7400	832	16500	1330	46000	2650
500	116	2100	362	4700	638	7600	845	17000	1360	48000	2730

Note 1: Masses shown refer either to stockless anchors or to stocked anchors excluding stocks. The proof load for intermediate masses may be determined by linear interpolation.

Note 2: For high holding power (HHP) anchors, the required proof load is derived from the Table, using a mass equal to 1,33 times the actual mass of the HHP anchor.

Note 3: For super high holding power (SHHP) anchors, the required proof load is derived from the Table, using a mass equal to twice the actual mass of the SHHP anchor.

1.6.2 Proof load test specifications

The load is to be applied between the shackle at one end and, at the other end, the arm/arms at a point located approximately one third of the length from its/their end. The test is to be performed in duplicate, in accordance with the following procedure:

- for anchors having four fixed arms, the load is to be applied first to one pair of arms and then to the opposite pair, applying it simultaneously to the pair concerned

- for stocked anchors with two fixed arms, the load in both tests is to be applied separately to both arms
- for stockless anchors with hinged arms, the load is to be applied in both opposite anchoring positions, and in each test it is to be applied simultaneously to the points of the arms mentioned above.

As far as the point of application of the load on the arms is concerned, the length of the arm is defined as :

- the length between the tip of each arm and the crown of the anchor, or
- the distance between the tips of the arms and the axis of rotation, in the case of stockless anchors with hinged arms.

For further details on the proof test, see Fig 2.

The difference between the gauge lengths a , defined in Fig 2, measured when the applied load is equal to 10% of the proof load and when the applied load is reduced from the proof load to 90% of the proof load, may be permitted not to exceed $0,01 a$.

Figure 2 : Proof load test

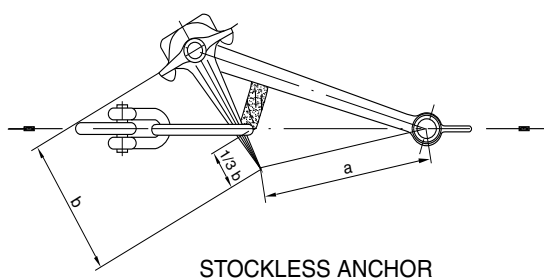
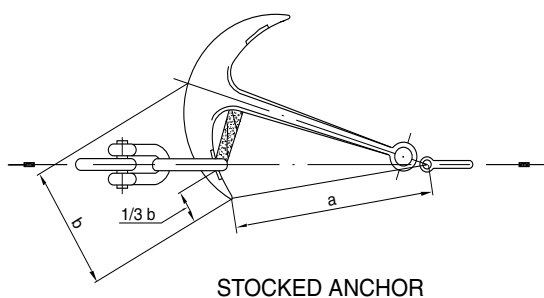
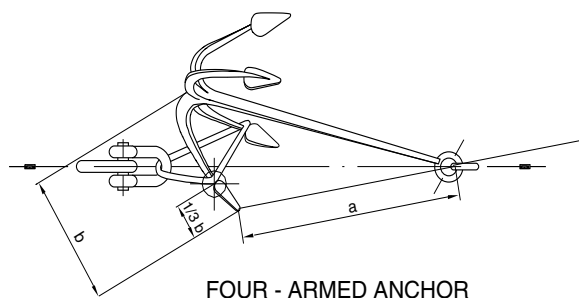

1.6.3 Examinations after proof load testing (1/1/2007)

After proof load testing, a visual examination intended to ascertain the absence of cracks, fractures, permanent deformations etc, is to be carried out anchors made in more than one piece are to be examined for free rotation of their heads over the complete angle.

1.6.4 Non-destructive tests for ordinary and HHP anchors (1/1/2007)

All cast anchors are to be inspected by dye penetrant testing or by magnetic particle examination in way of areas where feeder heads and risers have been removed and where weld repairs have been carried out.

1.6.5 Non-destructive tests for SHHP anchors (1/1/2007)

In addition to the requirements in [1.6.4], cast steel SHHP anchors are to be inspected by dye penetrant testing or by magnetic particle examination on all surfaces and by ultrasonic examination in way of areas where feeder heads and risers have been removed and where weld repairs have been carried out.

1.6.6 Non-destructive tests of welded anchors (1/1/2007)

Welded steel anchors are to be inspected by dye penetrant testing or by magnetic particle examination in way of the welded joints. In way of highly stressed or suspect areas of SHHP anchors, the Society may require ultrasonic or radiographic examination.

1.6.7 Testing machines

Testing machines are to be in accordance with requirements specified in Ch 1, Sec 2, [1.2.1].

1.7 Identification, marking, certification

1.7.1 (1/1/2007)

The Manufacturer is to adopt a system of identification which will enable all finished anchors to be traced to the original materials and their manufacturing.

Anchors which have been tested and inspected with satisfactory results are to be marked with the following details:

- Society's brand
- identification e.g, test no. or Certificate no.
- cast number or other marking which will enable the history of the fabrication of the material to be traced
- mass of the anchor (excluding the mass of the stock, if any, which is in any event to be stamped on the stock itself)
- the letters HHP or SHHP for high holding power or super high holding power anchors, respectively
- personal stamp of the Surveyor responsible for inspection (optional)
- Manufacturer's mark.

In addition to the above marking, each part of the anchors manufactured by casting or forging is to be marked by the Manufacturer with the words "cast steel" or "forged steel", respectively.

All the required marking is to be stamped on one side of the anchor reserved for this purpose; in the case of anchors made of more than one piece, such marking is to be stamped both on the shank and on one of the arms.

1.7.2 (1/1/2007)

The testing documentation indicated in Ch 1, Sec 1, [4.2.1] is required and is to include as a minimum the following information:

- Manufacturer's name
- Type
- Mass
- Fluke and Shank identification numbers
- Grade of materials
- Proof test loads
- Heat treatment
- Marking applied to anchor.

1.8 Painting**1.8.1 (1/1/2007)**

No type of anchor is to be painted until all tests and inspections have been completed.

2 Stud link chain cables and accessories**2.1 Application****2.1.1 General**

The requirements of this Article apply to the materials, design, manufacture and testing of stud link anchor chain cables and accessories used for ships.

2.2 Chain cable grades

2.2.1 Depending on the nominal tensile strength of the steel used for manufacture and on the type of manufacture, stud link chain cables are to be divided into the following grades:

- a) Q1a for flash welding - ordinary steel
- b) Q2a for flash welding and drop forging - high tensile steel
- c) Q2b for casting - high tensile steel
- d) Q3a for flash welding and drop forging - very high tensile steel
- e) Q3b for casting - very high tensile steel.

2.3 Approval of chain cable Manufacturers

2.3.1 Anchor chain cables and accessories are to be manufactured by works approved by the Society; approval tests are required.

Applications for approval are to provide detailed information about the production works and fabricated chains such as the method of manufacture, the grade of materials, the links' nominal dimensions, etc.

Where materials with chemical composition or properties other than those given in Tab 3 and Tab 4 are proposed, their acceptance is at the Society's discretion. The same applies in the case of design of links different from [2.9.2].

2.4 Steels for chain cables**2.4.1 General**

These requirements apply to rolled steels, forgings and castings used for the manufacture of anchor chain cables and accessories.

2.4.2 Requirements for material Manufacturers (1/7/2003)

All materials used for the manufacture of anchor chain cables and accessories are to be supplied by Manufacturers approved by the Society. Approval is not required for Grade Q1 steel bars.

Material suppliers of Grade Q3 chain cable Manufacturers are to submit specifications of the materials used. These specifications are to contain all necessary details, such as manufacturing procedure, deoxydation practice, specified chemical composition, heat treatment and mechanical properties.

2.5 Rolled steel bars**2.5.1 Supply condition**

Unless otherwise stipulated (i.e. heat treatment), the steel bars are supplied in the as-rolled condition.

The steel bars are to be supplied with a works' certificate indicating the chemical composition and the delivery condition.

2.5.2 Chemical composition

The chemical composition of steel bars is generally to be within the limits given in Tab 3.

2.5.3 Sampling for mechanical tests (1/7/2003)

For performance of mechanical tests, steel bars are to be sorted according to heats and diameters into batches not exceeding 50 t each. A test sample is to be taken from each batch for tensile tests and, when required depending on the grade, for impact tests. Prior to sampling, the test samples are to be subjected to the heat treatment provided for the finished chain cables; see Tab 6. Details of the heat treatment are to be provided by the chain cable Manufacturer.

The tensile and Charpy V-notch impact test specimens are to be taken from the test sample in the longitudinal direction at a distance of 1/6 diameter from the surface or as close as possible to this position (see Fig 3).

For the tensile test, one specimen is to be taken from each batch.

One set of longitudinal Charpy V-notch test specimens shall be taken from each test unit and tested at the temperature prescribed in Tab 4. The specimen transverse axis is to be radial to the steel bar. The average value obtained from one set of three impacts specimens is to comply with the requirements given in Tab 4. One individual value only may be below the specified average value provided it is not less than 70% of that value.

Table 3 : Chemical composition of rolled steel bars (1/7/2003)

Grade	Chemical composition in maximum percent, unless specified					
	C (%)	Si (%)	Mn (%)	P (%)	S (%)	Al tot (%) min. (1)
Q1a	0,20	0,15 - 0,35	min. 0,40	0,040	0,040	NR
Q2a (2)	0,24	0,15 - 0,55	max. 1,60	0,035	0,035	0,020
Q3a (3)	In accordance with an approved specification					

(1) Aluminium may be replaced partly by other grain refining elements.
(2) Subject to the agreement of the Society, additional alloying elements may be added.
(3) To be killed and fine grain.
NR = Not required.

Table 4 : Mechanical properties of rolled steel bars (1/7/2003)

Grade	R_{eH} (N/mm ²) min	R_m (N/mm ²)	A_5 (%) min	Z (%) min	Charpy V-notch impact test	
					Test temp. (°C)	Absorbed energy in Joules, min.
Q1a	NR	370 - 490	25	NR	NR	NR
Q2a	295	490 - 690	22	NR	0	27 (1)
Q3a	410	min 690	17	40	0 (2)	60
					-20	35

(1) The impact test of grade 2 materials may be waived if the chain cable is supplied in a heat treated condition as per Tab 7.
(2) Testing is normally to be carried out at 0° C.

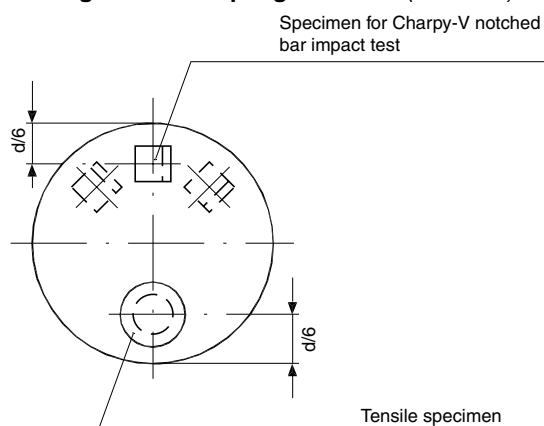
Figure 3 : Sampling locations (1/7/2003)**2.5.5 Re-tests (1/7/2005)**

For re-test procedures, reference is to be made to Ch 1, Sec 1, [3.5] with specimens taken from the same sample.

Failure to meet the specified requirements in either or both additional tests will result in rejection of the batch represented unless it is clearly attributable to improper simulated heat treatment.

If failure to pass the tensile test or the Charpy V-notch impact test is definitely attributable to improper heat treatment of the test sample, a new test sample may be taken from the same piece and reheat treated. The complete test (both tensile and impact tests) is to be repeated and the original results obtained may be disregarded.

2.5.4 Tests (1/7/2003)

Mechanical tests representing the steel bars are normally to be carried out by the steel mill and the results are to meet the requirements of Tab 4; however, the Society may allow mechanical testing on bars to be performed by the chain cable Manufacturer. Test coupons are to be in a heat treated condition equivalent to that of the finished chain cables and accessories.

A tensile test and, depending on the grade, an impact test (on three specimens) are required for each test sample. The mechanical tests are to be carried out in the presence of the Surveyor.

The test results are to be in agreement with the mechanical properties specified in Tab 4.

2.5.6 Freedom from defects

All products are to be checked by Manufacturers in relation to their surface conditions.

The materials are to be free from internal and surface defects which might impair proper workability and use. Surface defects may be repaired by grinding, provided the permissible tolerance is not exceeded.

2.5.7 Dimensional check - tolerances

The diameter and roundness are to be within the tolerances specified in Tab 5, unless otherwise agreed.

Table 5 : Dimensional tolerances of rolled steel bars

Nominal diameter (mm)	Tolerance on diameter (mm)	Tolerance on roundness $d_{max} - d_{min}$ (mm)
less than 25	-0 +1,0	0,60
25 - 35	-0 +1,2	0,80
36 - 50	-0 +1,6	1,10
51 - 80	-0 +2,0	1,50
81 - 100	-0 +2,6	1,95
101 - 120	-0 +3,0	2,25
121 - 160	-0 +4,0	3,00

2.5.8 Identification of material (1/7/2003)

Manufacturers are to effectively operate an identification system ensuring traceability of the material to the original cast.

2.5.9 Marking

The minimum markings required for the steel bars are the steelmaker's brand mark, the steel grade and an abbreviated symbol of the heat. Steel bars having diameters up to and including 40mm, and combined into bundles, may be marked on permanently affixed labels.

2.5.10 Material certification (1/7/2003)

Bar material for Grade Q2a or Grade Q3a is to be certified by the Society. For each consignment, the steelmaker is to provide the Surveyor with a certificate containing at least the following data:

- steel maker's name and/or purchaser's order no.
- number and dimensions of bars and weight of consignment
- steel specification and chain grade
- heat number
- manufacturing procedure
- chemical composition

- details of heat treatment of the test sample (where applicable)
- results of mechanical tests (where applicable)
- number of test specimens (where applicable).

2.6 Forged steels for chain cables and accessories**2.6.1 General requirements**

Forged steels used for the manufacture of chain cables and accessories are to be in compliance with Ch 2, Sec 3, unless otherwise specified in the following requirements.

2.6.2 Chemical composition

The chemical composition is to comply with the specification approved by the Society. The steel Manufacturer is to determine and certify the chemical composition of every heat of materials.

2.6.3 Heat treatment (1/7/2003)

The stock material may be supplied in the as-rolled condition. Finished forgings are to be properly heat treated, i.e. normalised or quenched and tempered, whichever is specified for the relevant steel grade.

2.7 Cast steels for chain cables and accessories**2.7.1 General requirements**

Cast steels used for the manufacture of chain cables and accessories are to be in compliance with Ch 2, Sec 4, unless otherwise specified in the following requirements.

2.7.2 Chemical composition

The chemical composition is to comply with the specification approved by the Society. The foundry is to determine and certify the chemical composition of every heat.

2.7.3 Heat treatment (1/7/2003)

All castings are to be properly heat treated, i.e. normalised, normalised and tempered or quenched and tempered, whichever is specified for the relevant cast steel grade.

Figure 4 : Typical design of chain links

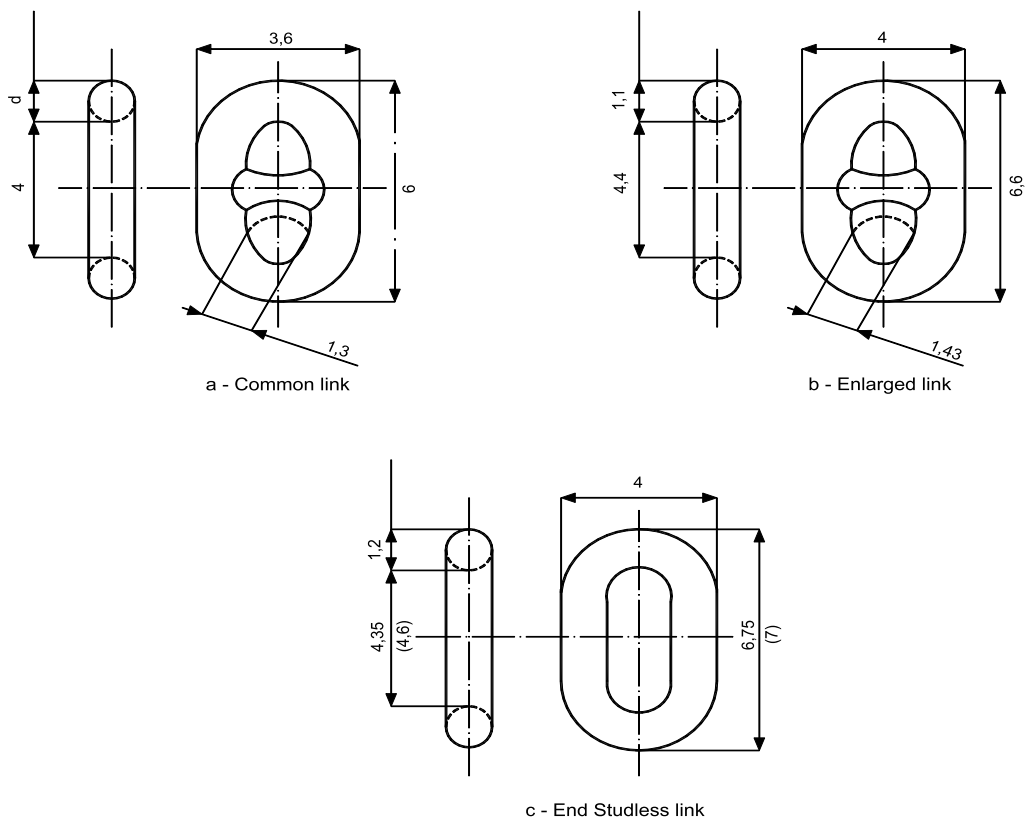

All dimensions are shown as multiples of the nominal diameter d of the common link.
 The dimensions in brackets may be chosen for end studless links in outboard end swivel pieces.

Figure 5 : Typical design of shackles and swivels

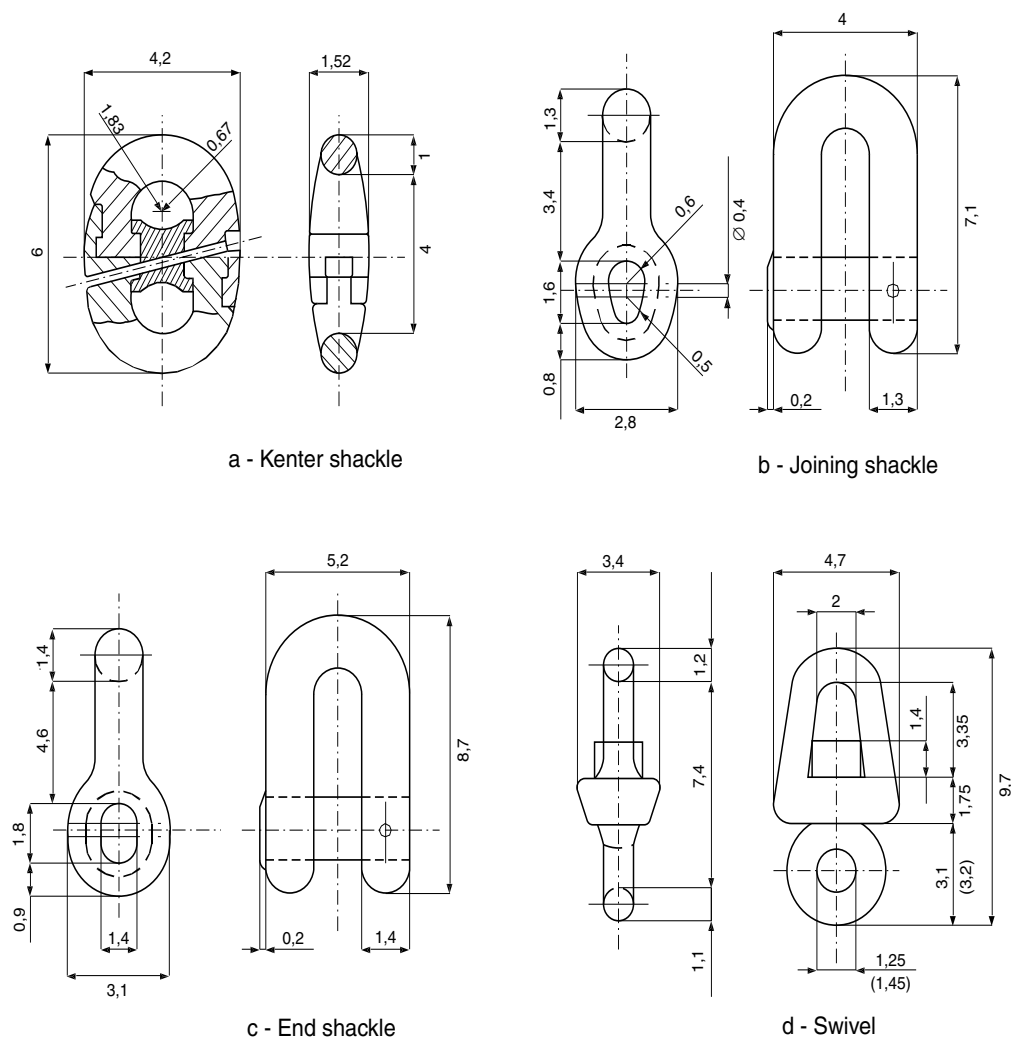

All dimensions are shown as multiples of the nominal diameter d of the common link.

For swivels, dimensions in brackets may apply to cast steel swivels.

2.8 Materials for studs

2.8.1 The studs are to be made of steel corresponding to that of the chain cable or from rolled, cast or forged ordinary steel, as indicated in the chain specification; grey or nodular cast iron is not permitted.

2.9 Design and manufacture

2.9.1 Manufacturing process (1/7/2003)

Stud link chain cables are preferably to be manufactured by flash welding using grade Q1, Q2 or Q3 steel bars. Manufacture of the links by drop forging or steel casting is permitted.

Accessories such as shackles, swivels and swivel shackles are to be forged or cast in steel of at least Grade 2. The welded construction of these parts may also be approved.

2.9.2 Design (1/1/2023)

Chain cables are to be designed according to a standard recognised by the Society, such as ISO 1704:2008. Typical designs are given in Fig 4 and Fig 5. Where designs do not comply with these figures and where accessories are of welded construction, drawings giving full details of the design, the manufacturing process and the heat treatment are to be submitted to the Society for approval.

A length of chain cable is to comprise an odd number of links.

2.9.3 Heat treatment (1/7/2003)

According to the grade of steel, chain cables and accessories are to be supplied in one of the conditions specified in Tab 6. The heat treatment is to be performed before the proof load test, the breaking load test, and all mechanical testing.

Table 6 : Condition of supply of chain cables and accessories (1/7/2003)

Grade	Chain cables	Accessories
Q1	As-welded or normalised	NA
Q2	As welded or normalised (1)	Normalised
Q3	Normalised, Normalised and tempered or quenched and tempered	Normalised, Normalised and tempered or quenched and tempered
(1) Grade Q2 chain cables made by forging or casting are to be supplied in the normalised condition. NA = Not applicable.		

2.9.4 Mechanical properties (1/7/2003)

The mechanical properties of finished chain cables and accessories are to be in accordance with Tab 8.

2.9.5 Proof and breaking load properties

Chain cables and accessories are to withstand the proof and breaking loads indicated in Tab 9, depending on the relevant chain cable grade.

2.9.6 Freedom from defects

All individual parts are to have a clean surface consistent with the method of manufacture and be free from cracks, notches, inclusions and other defects impairing the performance of the product. The flashes produced by upsetting or drop forging are to be properly removed.

Minor surface defects may be ground off so as to leave a gentle transition to the surrounding surface. Remote from the crown, local grinding up to 5% of the nominal link diameter may be permitted.

2.9.7 Dimensions and dimensional tolerances (1/1/2023)

The shape and proportions of links and accessories are to conform to a recognised standard (see Fig 4 and Fig 5) such as ISO 1704:2008 or the designs specially approved.

The permissible tolerances applicable to links are the following :

- Diameter measured at the crown (two measurements are to be taken at the same location: one in the plane of the link, see d_p in Fig 6, and one perpendicular to the plane of the link:
 - up to 40 mm nominal diameter: -1mm
 - over 40 up to 84 mm nominal diameter: -2 mm
 - over 84 up to 122 mm nominal diameter: -3 mm
 - over 122 mm nominal diameter: -4 mm
 - the plus tolerance may be up to 5% of the nominal diameter.

The cross-sectional area of the crown is to have no negative tolerance.

- Diameter measured at locations other than the crown:

The diameter is to have no negative tolerance. The plus tolerance may be up to 5% of the nominal diameter. The

approved Manufacturer's specification is applicable to the plus tolerance of the diameter at the flush-butt weld.

- The maximum allowable tolerance on assembly measured over a length of 5 links may equal +2,5%, but may not be negative (tolerance measured with the chain under tension after proof load test, which means chain loaded to about 10% of the proof load or stretched to full inter-link contact).
- All other dimensions are subject to a manufacturing tolerance of $\pm 2,5\%$, provided always that all parts of the chain cable fit together properly.
- Studs are to be located in the links centrally and at right angles to the sides of the link, although the studs of the final link at each end of any length may also be located off-centre to facilitate the insertion of the joining shackle.

The following tolerances are regarded as being inherent in the method of manufacture and are not to be objected to, provided that the stud fits snugly and its ends lie practically flush against the inside of the link.

Maximum off-centre distance "X": 10% of the nominal diameter d ,

Maximum deviation " α " from the 90°- position: 4°.

The tolerances are to be measured in accordance with Fig 6.

The following tolerances are applicable to accessories:

- nominal diameter : +5%, -0%
- other dimensions : $\pm 2,5\%$.

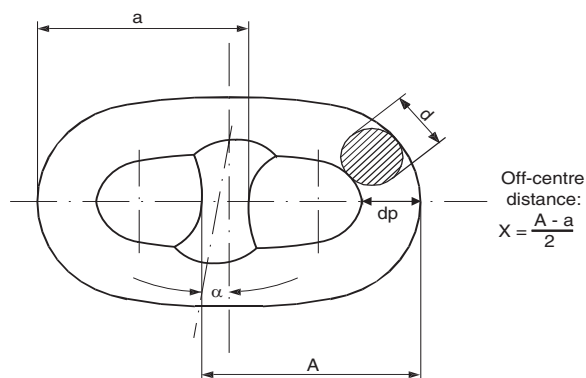
Figure 6 : Manufacturing tolerances**2.9.8 Welding of studs (1/7/2003)**

For all grades of stud link anchor chain cables, it is possible to secure studs on the links by welding.

The welding of chain studs is to be in accordance with an approved procedure subject to the following conditions:

- the studs are to be of weldable steel (see [2.8])
- the studs are to be welded at one end only, i.e., opposite to the weldment of the link. The stud ends are to fit the inside of the link without appreciable gap
- the welds, preferably in the horizontal position, are to be executed by qualified welders using suitable welding consumables

- d) all welds are to be carried out before the final heat treatment of the chain cable
- e) the welds are to be free from defects liable to impair the proper use of the chain. Under-cuts, end craters and similar defects are, where necessary, to be ground off.

The Society reserves the right to require a procedure test for the welding of chain studs.

2.10 Testing of finished chain cables

2.10.1 Proof and breaking load tests (1/7/2003)

- a) Finished chain cables are to be subjected to the proof load test and the breaking load test, in the presence of the Surveyor and are not to fracture or exhibit cracking. Special attention is to be given to the visual inspection of the flash-butt weld, if present. For this purpose, the chain cables are to be free from paint and anti-corrosion media.
- b) Each chain cable length (27,5 m) is to be subjected to a loading test at the proof load appropriate to the particular chain cable as given by Tab 9 using an approved testing machine.
- c) For the breaking load test, one sample comprising at least three links is to be taken from every four lengths or fraction of chain cables and tested at the breaking loads given by Tab 9. The breaking load is to be maintained for a minimum of 30 seconds. The links concerned are to be made in a single manufacturing cycle together with the chain cable and are to be welded and heat treated together with it. Only after this may they be separated from the chain cable in the presence of the Surveyor.
- d) If the tensile loading capacity of the testing machine is insufficient to apply the breaking load for chain cables of large diameter, another equivalent testing method is to be agreed with the Society.

2.10.2 Re-tests

- a) Should a breaking load test fail, a further sample may be taken from the same length of chain cable and tested. The test will be considered successful if the requirements are then satisfied.

If the retest fails, the length of chain cable concerned is rejected. If the Manufacturer so wishes, the remaining three lengths belonging to the batch may then be individually subjected to testing at the breaking load. If one such test fails to meet the requirements, the entire batch is rejected.

- b) Should a proof load test fail, the defective link(s) is (are) to be replaced, a local heat treatment to be carried out on the new link(s) and the proof load test is to be repeated. In addition, an investigation is to be made to identify the cause of the failure and the Society then decides on further action.

2.10.3 Mechanical tests on grade Q2 and Q3 chain cables (1/7/2003)

For grade Q2a and Q3a chain cables, mechanical test specimens required in Tab 7 are to be taken from every four lengths as hereunder specified. For forged or cast chain cables where the batch size is less than four lengths, the sampling frequency will be by heat and heat treatment charge. Mechanical tests are to be carried out in the presence of the Surveyor. For the location of the test specimens see [2.5.3] and Fig 3. Testing is to be in accordance with [2.5.3]. Retesting is to be in accordance with [2.5.5].

An additional link (or, where the links are small, several additional links) is (are) to be provided in a length of chain cable not containing the specimen for the breaking test. The specimen link(s) is (are) to be manufactured and heat treated together with the length of chain cable.

The mechanical properties and the impact energy are to be in accordance with the values indicated in Tab 8.

Table 7 : Number of mechanical test specimens for finished chain cables and accessories (1/7/2003)

Grade	Manufacturing method	Condition of supply (1)	Number of tests on every four lengths		
			Tensile test for base material	Charpy V-notch impact test	
				base material	weldment
Q1a	Flush-butt welded	AW,N	NR	NR	NR
Q2a	Flush-butt welded	AW	1	3	3
		N	NR	NR	NR
Q3a	Flush-butt welded	N, N+T, Q+T	1	3	3
Q2a, Q2b	cast or drop forged	N	1	3 (2)	NA
Q3a, Q3b	cast or drop forged	N, N+T, Q+T	1	3	NA

(1) AW = as welded; N = Normalised; N+T = Normalised and tempered; Q+T = Quenched and tempered.
(2) For chain cables, Charpy V-notch impact test is not required.
NR = Not required
NA = Not applicable

Table 8 : Mechanical properties of finished chain cables and accessories (1/7/2003)

Grade	R _{eH} N/mm ² min	R _m N/mm ²	A ₅ % min	Z % min	Charpy V-notch impact test		
					Test temperature in (°C)	Absorbed energy (J) min.	
						Base metal	Weldment
Q1	NR	NR	NR	NR	NR	NR	
Q2a, Q2b	295	490-690	22	NR	0	27	
Q3a, Q3b	410	690 min	17	40	0 (1) -20	60 35	

(1) Testing is normally to be carried out at 0 °C.
NR = Not required.

Table 9 : Formulae for proof load and breaking load tests (1/7/2003)

Test	Grade 1	Grade 2	Grade 3
Proof load (kN)	0,00686d ² (44-0,08d)	0,00981d ² (44-0,08d)	0,01373d ² (44-0,08d)
Breaking load (kN)	0,00981d ² (44-0,08d)	0,01373d ² (44-0,08d)	0,01961d ² (44-0,08d)

Note 1: d = nominal diameter, in mm.

2.10.4 Marking

Chain cables which meet the requirements are to be stamped at both ends of each length at least with the following marks, as indicated in Fig 7:

- chain cable grade
- certificate number
- Society's stamp.

2.10.5 Certification (1/7/2003)

Chain cables which meet the requirements are to be certified by the Society at least with the following items:

- Manufacturer's name
- grade
- chemical composition (including total aluminum content)
- nominal diameter/weight
- proof/break loads
- heat treatment
- marks applied to chain
- length
- mechanical properties, where applicable.

2.11 Testing of accessories

2.11.1 Proof load test (1/7/2003)

All accessories are to be subjected to the proof load test at the proof load specified for the corresponding chain in given by Tab 9, and in accordance with the provisions of [2.10.1], as appropriate.

2.11.2 Breaking load test (1/7/2003)

From each manufacturing batch (same accessory type, grade, size and heat treatment charge, but not necessarily representative of each heat of steel or individual purchase order) of 25 units or less of detachable links, shackles, swivels, swivel shackles, enlarged links and end links, and from

each manufacturing batch of 50 units or less of kenter shackles, one unit is to be subjected to the breaking load test at the break load specified for the corresponding chain given by Table 8 and in accordance with the provisions of [2.10.1], as appropriate. Parts tested in this way may not be put to further use. Enlarged links and end links need not be tested provided that they are manufactured and heat treated together with the chain cable.

The Society may waive the breaking load test if:

- the breaking load has been demonstrated during the approval testing of parts of the same design,
- the mechanical properties, of each manufacturing batch are proved, and
- the parts are subjected to suitable non-destructive testing.

Figure 7 : Marking of chain cables

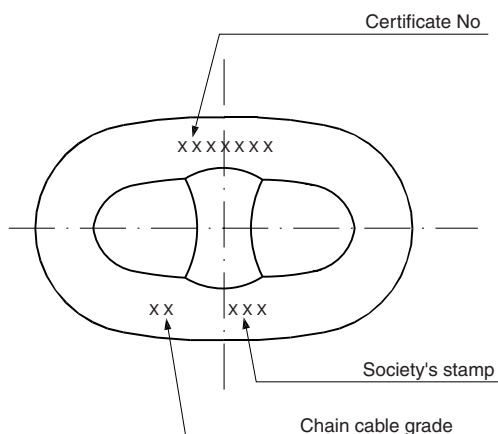

Notwithstanding the above, the accessories, which have been successfully tested at the prescribed breaking load appropriate to the chain, may be used in service, on a case

by case basis, where the accessories are manufactured with the following:

- a) the material having higher strength characteristics than those specified for the part in question (e.g. grade Q3 materials for accessories for grade Q2 chain)
- b) or, alternatively, the same grade material as the chain but with increased dimensions subject to the successful procedure test that such accessories are so designed that the breaking strength is not less than 1,4 times the prescribed breaking load of the chain for which they are intended.

2.11.3 Mechanical properties and tests (1/7/2003)

Unless otherwise specified, the forging or casting is at least to comply with the mechanical properties given in Tab 8, when properly heat treated. For test sampling, forgings or castings of similar dimensions originating from the same heat treatment charge and the same heat of steel are to be combined into one test unit.

Mechanical tests as described in [2.10] are to be carried out in the presence of the Surveyor, depending on the type and grade of material used.

From each test unit, one tensile test specimen and three Charpy V-notch impact test specimens are to be taken in accordance with Tab 7. For the location of the test specimens see [2.5.3] and Fig 3. Testing is to be in accordance with [2.5.4] and retesting is to be in accordance with [2.5.5]. Enlarged links and end links need not be tested provided that they are manufactured and heat treated together with the chain cable.

The toughness of anchor shackles for super high holding power anchors is to be such that the average energy of the Charpy V-notch impact test is not less than the value specified in [2.10.3] for grade Q3 anchor chain cables.

2.11.4 Marking

Accessories which meet the requirements are to be stamped as follows:

- chain cable grade
- certificate number
- Society' stamp.

2.11.5 Certification (1/7/2003)

Chain accessories which meet the requirements are to be certified by the Society at least with the following items:

- Manufacturer's name
- grade
- heat Number
- chemical composition (including total aluminum content)
- nominal diameter/weight
- proof/break loads
- heat treatment
- marks applied to accessory
- mechanical properties, where applicable.

3 Studless chain cables

3.1 Application

3.1.1 General

The requirements of this Article apply to the materials and testing of studless chain cables.

3.1.2 Manufacture (1/7/2003)

The requirements of [2.3.1] are to be complied with.

On request, pressure butt welding may also be approved for studless, grade 1 and 2 chain cables, provided that the nominal diameter of the chain cable does not exceed 26mm.

3.1.3 Studless chain cable grades

Depending on the nominal tensile strength of the steel used for manufacture, studless chain cables are divided into the following grades:

- SL1, SL2 and SL3 for steels in compliance with requirements for stud link steel grades Q1, Q2 and Q3, respectively.

3.1.4 Short and long links

The provisions of this Article apply to short studless link chain cables.

When long studless link chain cables are intended to be used, the steel properties are to be submitted by the Manufacturer. The tensile strength and yield stress minimum values are to be specially adapted for each grade, so that the chain cable can withstand the proof and breaking loads indicated in Tab 10 depending on the relevant chain cable grade.

As a rule, the use of long links is not permitted for SL3 studless chain cables.

3.2 Materials for studless chain cables

3.2.1 Requirements for materials

The general requirements concerning material Manufacturers, manufacturing procedure, supply condition, freedom from defects and dimensional tolerances are the same as those given in [2.4.2], [2.5.1], [2.5.6] and [2.5.7] for stud link chain cables.

The chemical composition and mechanical properties of steels to be used for manufacturing chains of grades SL1, SL2 and SL3 are to comply with the prescriptions given in Tab 4 (mechanical properties) and Tab 3 (chemical composition) for grades Q1, Q2 and Q3, respectively.

For SL3 chain cables, the minimum tensile requirements may be reduced down to 365 N/mm² (instead of 410 N/mm²) for yield stress and 610 N/mm² (instead of 690 N/mm²) for tensile strength on condition that the finished chain can withstand the required proof and breaking loads.

3.2.2 Testing of materials

The requirements for testing of material for studless chain cables of grades SL1, SL2 and SL3 are the same as for testing

of the corresponding grades Q1, Q2 and Q3, given in [2.5.4].

However, for grades SL1 and SL2, material testing in the presence of the Surveyor is not required, and the supply of a works' certificate may be admitted on condition that all the bars can be identified with the corresponding certificate.

3.3 Testing of finished chain cables

3.3.1 General

Studless chain cables and corresponding accessories are to withstand the proof and breaking loads indicated in Tab 10, depending on the relevant studless chain cable grade.

Mechanical testing on links is required for grade SL3 only.

3.3.2 Proof load test

All finished studless chain cables are to be subjected, over their full length, to a loading test at the proof load appropriate to the particular chain as shown in Tab 10. For the load test, an approved testing machine is to be used.

Re-tests are to be conducted as indicated in [2.10.2] b) for stud link chain cables.

3.3.3 Breaking load tests

Sample lengths, comprised of at least three links and taken every four 27,5 m lengths or every 110 m from the chain cables, are to be tested at the breaking loads shown in Tab 10.

The conditions for execution and separation of the three link samples are the same as those prescribed in [2.10.1] c).

Re-tests are to be conducted as indicated in [2.10.2] a) for stud link chain cables.

3.3.4 Mechanical tests on grade SL3 studless chain cables

For grade SL3, tensile tests and Charpy V-notch tests are to be performed as required for Q3 stud link chain cables (see [2.10.3]).

The values to be obtained are:

- tensile properties: the same values as required for the round bars used to manufacture the chain cables
- Charpy V-notch impact tests: the same as prescribed in Tab 8 for Q3 stud link chain cables.

No mechanical tests are required on links with a nominal diameter under 20 mm.

3.3.5 Dimensions and tolerances

The dimensions of links are to comply with a recognised standard. Typical design of a studless link is given in Fig 8.

The tolerances are the same as those prescribed in [2.9.7] for stud link chain cables.

Figure 8 : Studless link for studless chain cable

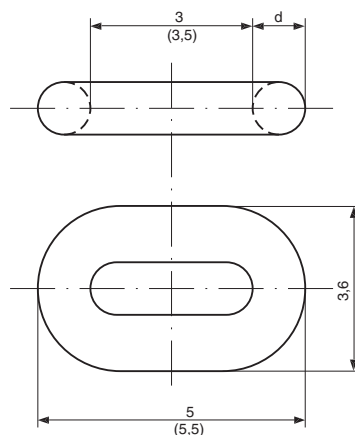

All dimensions are shown as multiples of the nominal diameter d . The dimensions in brackets correspond to long link chain cables.

Table 10 : Proof and breaking loads for studless chain cables

Chain cable diameter (mm)	Grade SL1		Grade SL2		Grade SL3		Mass of 100 m of chain	
	Proof load (kN)	Breaking load (kN)	Proof load (kN)	Breaking load (kN)	Proof load (kN)	Breaking load (kN)	Normal link (kg)	Short link (kg)
6,0	6,5	13	9	18	13	26	79	86
8,0	12,0	24	17	34	24	48	141	153
10,0	18,5	37	26	52	37	74	240	240
11,0	22,5	45	32	64	45	90	265	289
12,5	29,0	58	41	82	58	116	345	375
14,5	39,0	78	55	110	78	156	462	503
16,0	47,5	95	67	134	95	190	563	612
17,5	56,5	113	80	160	113	226	675	732
19,0	67,0	134	95	190	134	268	794	865
20,5	78,0	156	111	222	156	312	928	1005
22,0	90,0	180	128	256	180	360	1063	1155
24,0	106	212	151	302	212	424	1268	1380
25,5	120	240	170	340	240	480	1432	1560
27,0	135	270	192	384	270	540	1610	1742
28,5	150	300	213	426	300	600	1788	1942
30,0	166	332	236	472	332	664	1984	2155
32,0	189	378	268	536	378	756	2255	2480
33,0	201	402	285	570	402	804	2396	2605
35,0	226	452	321	642	452	904	2705	2940
37,0	253	506	359	718	506	1012	3020	3380
38,0	267	534	379	758	534	1068	3200	3460
40,0	296	592	420	840	592	1184	3520	3830

3.3.6 Galvanising in manufacture

When galvanising is required (mainly for pleasure craft), this is to be made by the hot process, following the standard ISO 1461.

The average mass of the coating (for chains above 5 mm in diameter) is not to be under 500 g/m². The tolerances given in [3.3.5] are to be maintained after the galvanising operations.

The required proof and breaking load tests are to be carried out after the galvanising is completed.

3.3.7 Marking

Studless chain cables which meet the requirements are to be stamped at both ends of each length as indicated in [2.10.4] for stud link chain cables.

4 Steel wire ropes

4.1 Application

4.1.1 General

The requirements of this Article apply to unalloyed steel wire ropes, round stranded, intended for warping, towing, rigging and similar applications.

4.1.2 Continuous production

In the case of continuous production, a specific procedure for testing and inspection may be allowed by the Society for approved Manufacturers at their request.

4.2 Manufacture

4.2.1 General

Wire ropes are to be manufactured in accordance with national or international standards recognised by the Society. In particular, ISO 2408 Standard is recognised.

The type and size of ropes are to be in accordance with the requirements specified for each application by the relevant part of the Rules or the approved plans relative to each installation.

Ropes of type and size different from those covered by this Article are considered in each case, taking into account their application; see also [4.2.4].

4.2.2 Rope materials

Ropes are to be manufactured with wires drawn from steel billets of appropriate and homogeneous quality; the steel is to be made by a process in accordance with Ch 1, Sec 2, [1.2].

Wires are not to show signs of defects and their surface is to be smooth and regular.

All the steel wires of a wire rope are to be of the same tensile grade, generally including those forming the metal core, if any.

As a rule, wires having the minimum nominal tensile strength R_m in the range 1420 - 1960 N/mm² are to be used.

The fibre core of the ropes or of the strands may be made of natural fibres (manilla, abaca, sisal, hemp, jute, cotton) or of synthetic fibres (polyethylene, polypropylene, polyamid, polyester).

4.2.3 Galvanising

All types of wire ropes are to be zinc-coated, except in special cases to be considered individually by the Society and generally involving limitation in the use of the wire ropes concerned.

Galvanising procedures and their results (in particular, degree of bonding and uniformity of the coating) are to be suitable and to the satisfaction of the Society.

The wires are to be galvanised so that the zinc mass satisfies the values specified in Tab 11.

4.2.4 Manufacturing process and facilities (1/1/2011)

The manufacturing procedures and relevant facilities are to be suitable and such as to ensure production of the required quality. Ropes having wire with nominal tensile strength greater than 1960 N/mm² and ropes of construction different from the recognised standard are to be approved for the individual Manufacturers in accordance with the requirements of the Rules for the Approval of Manufacturers of Materials or accepted on a case-by-case basis.

Table 11 : Galvanising of the wires of wire ropes

Diameter d of galvanised wires (mm)	Minimum mass of zinc coating (g/m ²)	
	Class A	Class B
0,45 ≤ d < 0,50	75	40
0,50 ≤ d < 0,60	90	50
0,60 ≤ d < 0,80	110	60
0,80 ≤ d < 1,00	130	70
1,00 ≤ d < 1,20	150	80
1,20 ≤ d < 1,50	165	90
1,50 ≤ d < 1,90	180	100
1,90 ≤ d < 2,50	205	110
2,50 ≤ d < 3,20	230	125
3,20 ≤ d < 4,00	250	135

The required tests and examinations are to be performed with the appropriate equipment and procedures recognised by the Society; the testing machine is to be calibrated.

4.2.5 Quality of materials

Ropes are to be free from material or manufacturing defects which might impair their intended application, their effi-

ciency, or their expected life span; in particular, they are to be free from oxidising or corrosion traces and there is to be no sign of broken wires, scratching, crushing or defective twisting.

4.2.6 Dimensional tolerances

Unless otherwise specified, the tolerances on the diameter given in recognised standards such as ISO 2408 apply; in particular, for the ropes considered in these Rules, the tolerances on the diameter are specified in Tab 12.

Table 12 : Permissible tolerances on nominal diameter

Nominal diameter of rope (mm)	Tolerance on the nominal diameter (%)	
	Ropes having strands with fibre core	Ropes having strands with metal core
< 8	+7 ; -1	+5 ; -1
≥ 8	+6 ; -1	+4 ; -1

4.3 Types of ropes

4.3.1 General (1/1/2011)

The wire ropes consist of an assembly of several strands laid around a fibre or metal core.

The types of ropes most commonly used are shown in Tab 13.

4.3.2 Main characteristics (1/1/2011)

The typical characteristics of the ropes are generally the following:

- diameter (of the circumference enclosing a cross-section of the rope; to be measured with the rope strained under a load of approximately 1/20 of its minimum breaking strength)
- construction (number and type of the cores, strands and wires)
- coating or type of surface finish of the steel wires
- minimum breaking load: the minimum value specified in the agreed standard (see [4.2.1] and [4.2.2]) for the relevant type of rope.

4.4 Sampling and testing

4.4.1 Sampling (1/1/2011)

Acceptance tests are to be performed on each rope length (defined as either one single length or multiple lengths manufactured with continuity).

Where the rope length is greater than 10000 m, the acceptance tests are to be carried out for every portion of 10000 m or fraction thereof.

When the base material used has the same origin and characteristics, the acceptance tests required in [4.4] for each rope length may be performed for each rope construction and diameter.

Suitable sampling and identification procedures are to be adopted, to the Surveyor's satisfaction.

The tests and examinations under [4.4.2], [4.4.3] or [4.4.4], [4.4.6] and [4.4.8] are to be performed for acceptance.

The tests under [4.4.5] and [4.4.7] are to be carried out when specified in the order or required by the Surveyor as a production check or in the case of Manufacturer approval.

4.4.2 Visual examination and check of the diameter and construction

The examination and checks are to be performed by the Manufacturer and random checks are to be carried out by the Surveyor to the extent deemed necessary.

4.4.3 Breaking test on full size specimens (1/1/2011)

Samples and testing procedures are to be in compliance with recognised standards, such as ISO 3108.

The test sample is to be long enough to obtain a clear distance, between terminals (e.g. clamp or splicing), at least equal to 30 times the diameter of the ropes, with a minimum of 600 mm.

The above clear distance may be reduced to 300 mm if the diameter is less than 6 mm.

During the test, when the applied load has exceeded approximately 80% of the required breaking load, the load is to be applied slowly and steadily (about 10 N/mm² per second).

The measured breaking load is to be not less than the minimum value specified in the agreed standard applied for each type and diameter of rope.

The result of the test may be disregarded if the specimen breaks outside the gauge length, in particular in way of the

terminals and if the minimum breaking load has not been achieved.

4.4.4 Breaking test on individual wires

As an alternative, when the breaking test on full size specimens cannot be performed, the breaking strength of the rope may be determined, in agreement with the Surveyor, as the sum of the actual breaking strengths determined on the individual wires, multiplied by the factor K (realisation factor) applicable in relation to the type and construction of the rope.





The factor K applicable to types of rope in current use is given in Tab 14 (for other types of ropes, the factor K is stated by the Society in each case).

The tensile test is to be performed on at least 10% of the wires of the rope to be tested, with a minimum of two wires per strand.

The wires tested are to satisfy the tensile requirements specified for the wires and the total breaking load of the n wires tested multiplied by the ratio N/n (where N is the total number of wires of the rope) and by the factor K (depending on the type of the rope) is to be not less than the minimum value specified by the recognised standard applied.

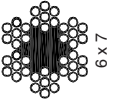
The acceptance of the check of the breaking load of the rope by means of tensile tests on individual wires is, in general, subject to a number of proof tests on samples of full size ropes which are representative of the production for comparison purposes.

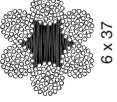
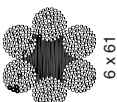
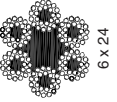
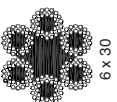
Table 13 : Common types of wire ropes (1/1/2011)

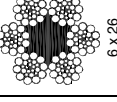
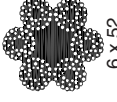
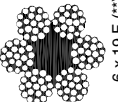
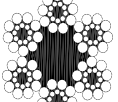
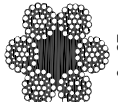
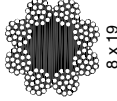
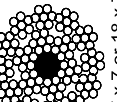
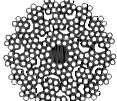
Composition of wire rope	 6 x 7	 6 x 19	 6 x 37
Composition and type of strands	1 + 6 Ordinary	1 + 6 + 12 Ordinary	1 + 6 + 12 + 18 Ordinary
Composition of wire rope	 6 x 61	 6 x 24	 6 x 30
Composition and type of strands	1 + 6 + 12 + 18 + 24 Ordinary	Fibre core + 9 + 15 Ordinary	Fibre core + 12 + 18 Ordinary
Composition of wire rope	 6 x 19	 6 x 26	 6 x 52
Composition and type of strands	1 + 6 + (6 + 6) Warrington	Composition of type 1 + n + (n + n) + 2n n = 5 n = 6 n = 7 n = 8 Warrington - Seale	1 + 6 + 9 + (9 + 9) + 18 Warrington - Seale
Composition of wire rope	 6 x 19 F (**)	 6 x 25	 6 x 37
Composition and type of strands	1 + 9 + 9 1 + (6 + 6 F) + 12 Seale	1 + 6 + 9 + 9 Seale	1 + 6 + 15 + 15 Seale
Composition of wire rope	 8 x 19	 17 x 7 or 18 x 7	 1 + 6
Composition and type of strands	1 + 9 + 9 1 + (6 + 6 F) + 12 Seale	1 + 6 Ordinary	1 + 6 Ordinary

4.4.5 Check of the strength of individual wires

This check, consisting of tensile tests on individual wires, is performed only when specified in the purchase order or required by the Surveyor as a check on the base materials employed.

Table 14 : Realisation factor K

Construction of rope (1)	Construction of strands (2)	Type of rope stranding (3)	Realisation factor K (4)	
			Fibre core (5)	Metal core (6)
6 x 7	1 + 6	O	0,90	0,870
6 x 19	1 + 6 + 12	O	0,87	0,835
6 x 19	1 + 9 + 9	S	0,87	0,835
6 x 19 F (7)	1 + (6 + 6 F) + 12	S - F	0,87	0,835
6 x 19	1 + 6 + (6 + 6)	W	0,87	0,835
6 x 24	fibre core + 9 + 15	O	0,87	-
6 x 25	1 + 6 + 9 + 9	S	0,86	0,825
6 x 26	1 + 5 + (5 + 5) + 10	W - S	0,85	0,815
6 x 30	fibre core + 12 + 18	O	0,87	-
6 x 31	1 + 6 + (6 + 6) + 12	W - S	0,85	0,815
6 x 36	1 + 7 + (7 + 7) + 14	W - S	0,85	0,815
6 x 37	1 + 6 + 12 + 18	O	0,85	0,815
6 x 37	1 + 6 + 15 + 15	S	0,85	0,815
6 x 41	1 + 8 + (8 + 8) + 16	W - S	0,85	0,815
6 x 52	1 + 6 + 9 + (9 + 9) + 18	W - S	0,81	0,775
6 x 61	1 + 6 + 12 + 18 + 24	O	0,81	0,775
8 x 19	1 + 9 + 9	S	0,83	-
8 x 19 F (7)	1 + (6 + 6 F) + 12	S - F	0,83	-
17 x 7	1 + 6	O	0,84	0,815
18 x 7	1 + 6	O	0,84	0,815
34 x 7	1 + 6	O	0,80	0,790
36 x 7	1 + 6	O	0,80	0,790

(1) The first figure gives the number of strands, the second the number of wires in each strand.
(2) The figures give the number of wires for each layer; the figures in brackets are relevant to wires of the same layer but of two different diameters. The letter F indicates filler wires.
(3) The type of rope stranding indications are as follows:
• O : ordinary strands (non-parallel wires);
• S, S-F, W and W-S (strands with parallel wires) : designate Seale, Seale-Filler, Warrington and Warrington-Seale strandings, respectively.
(4) The coefficient K is to be reduced by 3% for preformed ropes.
(5) The fibre core is not considered in the breaking load of the rope.
(6) The metal core consists of an independent rope (in general 6x7 with centre strand of 7 wires); it may, however, consist of a single strand for wire ropes of 6x7 and 6x19 wires with ordinary strands.
(7) 6x19 and 8x19 Filler wire ropes are sometimes designated by 6x25 Filler and 8x25 Filler, respectively.

Table 15 : Torsion test for wires - Minimum number of twists

Diameter d (mm)	Galvanising class A			Galvanising class B			
	Tensile grade, in N/mm ²			Tensile grade, in N/mm ²			
	1420	1560	1770	1420	1560	1770	1960
$d < 1,3$	19	18	17	31	29	26	18
$1,3 \leq d < 1,8$	18	17	16	30	28	25	17
$1,8 \leq d < 2,3$	18	17	16	28	26	25	16
$2,3 \leq d < 3,0$	16	14	12	26	24	22	15
$3,0 \leq d < 3,5$	14	12	10	24	22	20	13
$3,5 \leq d < 3,7$	12	10	8	20	20	18	12

4.4.6 Torsion test and coiling test on individual wires

Unless otherwise specified in the purchase order, in general only one of these tests is to be performed.

The tests are to be carried out on specimens obtained after galvanising from at least 5% of the number of wires taken at random in several strands with a minimum of 6 wires and a maximum of 10 wires for each diameter.

- Torsion test

The gauge length of the wire specimens, measured between the end terminals, is to be 100 times the wire diameter, but need not exceed 300 mm for wire diameters above 3 mm.

The wire is to be well clamped at the ends and well strained, e.g., under an axial load not exceeding 2% of its nominal breaking load.

The wire is then subjected to torsion until fracture occurs; the torque is to be applied as uniformly as possible, at the approximate rate of 60 - 70 revolutions per minute. The minimum required number of twists without fracture is specified in Tab 15.

The torsion test is not required for wires of diameter lower than 0,5 mm.

- Coiling test

The test consists of coiling a specimen of wire of sufficient length 8 times, in closed coils, around a cylindrical mandrel having a diameter equal to that of the wire; the wire is to be subsequently uncoiled and straightened.

After having been coiled, the zinc coating is not to show any sign of significant cracks or laminations. In the subsequent uncoiling and straightening, fracture of the wire is not to occur.

4.4.7 Checks of the zinc mass

The mass of zinc coating per unit area is required to be checked in accordance with a recognised standard.

The results of this test are to demonstrate compliance with the minimum required values specified in Tab 11.

4.4.8 Check of the uniformity and continuity of the zinc coating

This test is only performed when specified in the purchase order or required by the Surveyor as a production check. It

applies only to wires of diameter ≥ 1 mm if galvanised of class A and of diameter $\geq 0,6$ mm if galvanised of class B.

The tests are to be carried out on specimens obtained after galvanising from at least 5% of the number of wires taken at random in several strands with a minimum of 6 wires and a maximum of 10 wires for each diameter.

Unless otherwise specified, the test is performed by submerging a specimen in a water solution of pure crystalline copper sulphate ($\text{Cu SO}_4 \cdot 5 \text{H}_2\text{O}$) containing at least 360g of salt per litre of distilled water at a temperature of $20^\circ\text{C} \pm 2^\circ\text{C}$.

The specimen is to be immersed for a length of at least 80 mm and is to be maintained in vertical position.

Table 16 : Check of zinc continuity on wire coating

Diameter d of galvanised wire (mm)	Number of one-minute submersions (1)	
	Class A	Class B
$0,6 \leq d < 1,0$	-	0,5
$1,0 \leq d < 1,5$	1,5	1,0
$1,5 \leq d < 1,9$	2,0	1,0
$1,9 \leq d < 2,5$	2,0	1,5
$2,5 \leq d < 3,2$	2,5	1,5
$3,2 \leq d < 3,7$	3,0	2,0
(1) 1,5 submersion means one submersion lasting 1 minute followed by another lasting 30 seconds (the same criteria applies for the other numbers).		

Tab 16 shows the minimum number of one-minute submersions, in relation to the wire diameter and galvanising class. After each submersion, the specimen is to be rinsed in running water so as to wash away unbonded copper deposits.

The test is regarded as satisfactory when the specimen does not show (beyond 25 mm from the immersed end) indications of bonded copper deposits, which would mean local lack of zinc coating on the steel surface.

4.5 Identification marking and certification

4.5.1 Upon satisfactory completion of the required tests and examinations, the ropes, packed in the required length for supply, are to be tagged with lead seals stamped with the Society's brand and further indications, as necessary for identification with the respective test certificates.

4.5.2 The certificates are to contain the essential elements relevant to the rope characteristics, the results of the test and the stamps and markings mentioned in [4.5.1].

Special marking and certification methods may be agreed upon for supplies by Manufacturers granted the use of an alternative testing procedure.

5 Fibre ropes

5.1 Application

5.1.1 General

The requirements of this Article apply to natural and synthetic fibre ropes, intended for towing and mooring lines, cargo handling gear or similar applications.

5.1.2 Continuous productions

In the case of continuous production, the Manufacturers may adopt an alternative procedure for testing and inspection subject to the approval of the Society.

5.2 Manufacture

5.2.1 General

Fibre ropes are to be manufactured in accordance with national or international standards recognised by the Society (see [5.3]).

The type and size of ropes are to be in accordance with the requirements specified for each application by the relevant part of the Rules or the approved plans relative to each installation.

5.2.2 Rope materials (1/7/2007)

Ropes are to be manufactured with natural or synthetic fibre; the natural fibre is to be of suitable type and consistency, free from defects or harmful imperfections. Synthetic fibres are to be of a type and quality which have been recognised as suitable for the intended application.

5.2.3 Manufacturing process and facilities

The manufacturing procedures and relevant facilities are to be suitable and such as to ensure production of the required quality.

The manufacturing process is to be recognised as appropriate by the Society.

No addition of other materials is to be made and treatments intended to increase the mass of the finished rope are not to be used; additions of suitable lubricants are to be kept to an absolute minimum.

Treatments intended to prevent decaying and moisture absorption are not to impair the quality of the fibre or the strength of the rope.

The required tests and examinations are to be performed with the appropriate machinery, equipment and procedures recognised by the Society; the testing machine is to be calibrated.

In particular the dynamometer is to be of a type allowing a constant rate of traverse of the moving element (see [5.4.4]). Other types of dynamometer may be considered by the Society in each case.

5.2.4 Quality of ropes - Dimensional tolerances

Ropes are to be free from harmful material or manufacturing defects. As regards lengths, tolerances, marking and packaging, reference is to be made to the requirements specified in the applied standards and in the purchase order.

5.3 Type of ropes

5.3.1 (1/1/2011)

In general, ropes should have either 3-4 strands (plain ropes) or 8 strands (plaited ropes); however, other types of construction may be considered for acceptance by the Society.

The diameter of mooring lines is to be not less than 20mm.

Ropes may be made of hemp, manila, sisal or synthetic fibres (see [5.2.2]).

The following types and qualities of ropes, complying with recognised standards, are acceptable:

- three- or four-strand hemp ropes, EN 1261
- three, four- and eight-strand manila and sisal ropes, ISO 1181
- three-strand polyamide ropes, ISO 1140
- three-strand polyester ropes, ISO 1141
- three, four- and eight-strand polypropylene ropes, ISO 1346.

5.4 Sampling and testing

5.4.1 Sampling

Acceptance tests are to be performed on each rope length (defined as either one single length or multiple lengths manufactured with continuity).

Where the rope length is greater than 2000 m, the acceptance tests are to be carried out for every portion of 2000 m.

When the base material used has the same origin and characteristics, the acceptance tests required in [5.4] for each rope length may be performed for each rope construction and diameter.

Suitable sampling and identification procedures are to be adopted, to the Surveyor's satisfaction.

The tests and examinations under [5.4.2], [5.4.3] and [5.4.4] or [5.4.5] are to be performed for acceptance.

5.4.2 Visual examination and check of the diameter and construction

The check of diameter is to be performed during the breaking test. The sample is to be arranged on the testing machine and the diameter of rope (diameter of the circumscribed circumference) is to be measured under the reference load specified in Tab 17.

The visual examination and the check of correct construction and twist are to be performed by the Manufacturer, while random checks are carried out by the Surveyor to the extent deemed necessary.

The results are to comply with the applicable standards.

5.4.3 Check of the linear mass

The linear mass m is given by the formula:

$$m = \frac{m_0}{L}$$

where:

- m_0 : Mass, in grams, of the test piece
- L : Length, in metres, of the test piece under the reference load (see Tab 17), equal to:

$$L = \frac{D_p L_0}{D_0}$$

with:

- D_0 : Initial distance (at least 0,5 m) between the reference marks spaced symmetrically about the mid-point of the test piece when this is laid out by hand on a flat surface
- D_p : Distance between these marks measured under the reference load specified in Tab 17
- L_0 : Initial total length of the test piece (laid out by hand on a flat surface).

5.4.4 Breaking test on full size specimen (1/1/2011)

The breaking load is to be determined by testing to destruction a sample of rope of sufficient length; in general, the gauge length of the sample is to be not less than 1800 and 900 mm for vegetable fibre ropes and synthetic fibre ropes, respectively.

After the visual and dimensional examination performed at the prescribed load (see [5.4.2]), the sample is subjected to a tension load, steadily increased until fracture occurs.

Depending upon the type of fibre used in manufacturing the ropes, the rate of application of the test load is to be 120-180 mm/min for vegetable fibre ropes and 50-100 mm/min for synthetic fibre ropes.

In the case of synthetic fibre ropes for mooring, the value of elongation A , expressed in percent as given by the following formula, is also to be checked:

$$A = \frac{D_f - D_i}{D_i}$$

where:

- D_f : Distance between marks, on the test specimen, under a load equal to 75% of the minimum specified breaking strength.
 - D_i : Distance between marks measured under the initial reference load.
- D_f may be determined by stopping, for as short a time as possible, the action of the moving element, when the tensile load has reached 75% of the minimum specified breaking strength

Table 17 : Load to be applied to ropes for the measurement of the linear mass and diameter (1/1/2011)

Nominal diameter (mm)	Reference load (kN) Tolerance: ± 5%	Nominal diameter (mm)	Reference load (kN) Tolerance: ± 5%
4	0,020	32	1,28
6	0,045	36	1,62
8	0,080	40	2,00
9	0,101	44	2,42
10	0,125	48	2,88
12	0,180	52	3,38
14	0,245	56	3,92
16	0,320	60	4,50
18	0,405	64	5,12
20	0,500	68	5,78
22	0,605	72	6,48
24	0,720	76	7,22
26	0,845	80	8,00
28	0,980	88	9,68
30	1,13	96	11,5

Alternative types of test pieces and testing procedures, in accordance with recognised standards, may be considered by the Society.

The measured breaking load is to be not less than those of the standards listed in [5.3.1].

If the test piece breaks at the terminals (clamp or splice), the test requirements are considered to have been met if the measured break occurs at a load not less than 90% of the minimum breaking load given by the reference standard. It is not to be assumed that the actual breaking load of the specimen is represented by multiplying the result by 10/9.

The value of elongation A, for which no minimum requirements are given, is used only for determination of the equivalence between synthetic and natural fibre ropes with the formula given in Pt B, Ch 10, Sec 4, [3.5.7], and therefore for definition of the minimum breaking load of the synthetic fibre ropes for mooring, in relation to the Equipment Number of the ship.

5.4.5 Breaking test on individual yarns (1/1/2011)

When the breaking test on full size test pieces cannot be performed, alternative test procedures may be considered and, if used, they are to be reported in the relevant testing documentation.

To this end, the procedure outlined in Annex B to ISO Standard 2307 is appropriate.

5.5 Identification, marking and certification

5.5.1 Upon satisfactory completion of the required tests and examinations, the ropes, packed in the required length for supply, are to be tagged with lead seals stamped with the Society's brand and further indications, as necessary for identification with the respective test certificates.

5.5.2 The certificates are to contain the essential elements relevant to the rope characteristics, the results of the test and the stamps and markings mentioned in [5.5.1].

Special marking and certification procedures may be agreed upon for supplies by Manufacturers granted the use of an alternative testing procedure.

6 Side scuttles, windows and their glass panes

6.1 Application

6.1.1 The requirements of this Article apply to fixed frames, window frames, dead covers and glass panes.

The types of sidescuttles and windows which, in relation to their position, are to be tested are indicated in Pt B, Ch 9, Sec 9.

6.2 Manufacture

6.2.1 General

Sidescuttles and windows which are subject to inspection are to be manufactured in accordance with approved plans or standards and specifications recognised by the Society.

Manufacturing procedures are to be of appropriate type, to the Surveyor's satisfaction.

6.2.2 Frame materials

Materials are to be of appropriate type and properties, as required in the approved plans or applicable standards.

They are to comply with the requirements of Chapter 2, in relation to the type of material and the nature of the product.

Subject to approval for each case or application, the following types of material and products are generally regarded as appropriate:

- hull steel plates, shapes and bars having R_m in the range 400-490 N/mm²
- steel forgings and castings
- brass plates, shapes, bars and castings
- light alloy castings and semi-finished products, of category Al-Mg or Al-Mg-Si.

Subject to approval in individual cases, nodular cast iron of type GS400 or GS370 may also be used.

6.2.3 Glass panes

The glass panes are to be of appropriate type and quality, manufactured in accordance with suitable procedures, to the satisfaction of the Society, by recognised Manufacturers.

6.2.4 Quality of materials

The product is to be free from detrimental defects.

6.3 Inspections and tests

6.3.1 Frame material tests

Materials are to comply with the applicable requirements and to be tested or certified accordingly; depending on the individual cases, they are also to be submitted to the following additional tests :

a bend test, as indicated below, depending on the type of material:

- brass products: $d \leq 1 \text{ s}$ $\alpha \geq 60^\circ$
- light alloy products: $d \leq 3 \text{ s}$ $\alpha \geq 60^\circ$
- cast iron: $d \leq 4 \text{ s}$ $\alpha \geq 60^\circ$

where:

s : Thickness of the specimen (which, as far as possible, should be equal to the thickness of the product)

d : Diameter of the mandrel

α : Required bend angle, which is to be attained without cracks or other defects.

For castings, as an alternative to the bend test performed on specimens, it may be agreed to perform a bend test directly on a completed piece. Such test may also be required by the Surveyor as an additional random check. When this test is performed as an alternative to that on specimens, the number of pieces tested is to be one for every batch of not more than 50 equal pieces (25 in the case of cast iron products) originating from the same heat.

These tests are to be performed on a mandrel having a diameter equal to twice the thickness of the piece (but not less than 50 mm in the case of cast iron products); the required bend angles which are to be attained without cracks or other defects depending upon the material and the finished product are as follows:

- steel castings:
fixed frames, window frames and dead covers: $\alpha \geq 20^\circ$
- brass castings:
fixed frames and window frames: $\alpha \geq 10^\circ$
dead covers: $\alpha \geq 15^\circ$
- light alloy castings:
fixed frames and window frames: $\alpha \geq 6^\circ$
dead covers: $\alpha \geq 15^\circ$
- malleable or nodular cast iron: $\alpha \geq 15^\circ$.

6.3.2 Glass panes

Glass panes are to be in toughened safety glass in accordance with ISO 21005 standards. The acceptance of ordinary glass is subject to special approval by the Society in each case.

The glass Manufacturer is to certify the homogeneity of the batches submitted for tests, as regards material, manufacturing procedure, heat treatment and suitability to meet the specified test requirements.

Glass panes are to be tested as specified in the following items a) or b).

- a) a hydrostatic test of one glass pane for each batch of 100 (or fraction of 100) glass panes equal in shape and dimensions and manufactured with continuity and using the same procedure and treatments; the pane is to be tested with a load uniformly distributed on the net area, at the test pressures indicated in Tab 18, in relation to the diameter and thickness of the pane.

The test pressure is to be applied for at least one minute; the glass pane is not to break.

In the case of glass panes having shape other than circular, the test is to be performed on a disk obtained from a glass pane for each batch homogeneous as regards dimensions, manufacturing procedure and heat treatment and with a total surface of 25m² or fraction thereof. The disk, for the test and possible re-tests, is to be taken before the tempering process and treated with the glass panes of the batch which it represents.

If a test produces unsatisfactory results, the test is to be repeated in duplicate on two new glass panes from the same batch; for the acceptance of the batch, both new tests are to be satisfactory; in the case of tempered glass panes of non-circular shape, in order not to have to reject the batch in the case of unsatisfactory test results, it is recommended that two additional disks should be taken for possible re-testing from the batch before the tempering treatment.

- b) a punch test in accordance with ISO 614 as an alternative to the hydrostatic test mentioned in a).

This test method is applicable both to non-opening and opening sidescuttles and rectangular windows; when

tested, the glass edges are to be not less than 25mm from the inner edge of the rubber ring (see Fig 9).

The test consists of applying to the glass pane, which is supported by a steel plate with a circular hole, the required load through a rounded steel shaft acting along the centre of the hole.

The test is to be performed on 4 glass panes for each batch homogeneous as specified in a).

In the case of batches of 4 glass panes or less, the test is to be performed on each glass pane.

In the case of matt glass panes obtained by a special treatment of one of the surfaces of a transparent glass pane, the test is to be performed after the treatment and the load is to be applied to the surface which has not been treated.

The required test loads are indicated in Tab 19, in relation to the thickness of the glass pane and the diameter of the hole in the support plate.

The test is to be performed using the equipment and the procedure specified in ISO 614 Standard (see Fig 9).

Table 18 : Hydrostatic test pressure for glass panes of sidescuttles and windows (1/7/2021)

Thickness of glass pane (mm)	Pressure (N/mm ²) for a glass pane net diameter (mm) of:					
	200	250	300	350	400	450
4	0,33	0,21	-	-	-	-
5	0,33	0,21	-	-	-	-
6	0,33	0,21	-	-	-	-
8	0,58	0,37	0,26	0,19	-	-
10	0,92	0,58	0,41	0,30	0,23	0,18
12	1,32	0,84	0,59	0,43	0,33	0,26
15	-	1,32	0,92	0,67	0,51	0,41
19	-	-	1,47	1,08	0,83	0,65

Table 19 : Punch test load (1/7/2021)

Thickness of glass pane (mm) (tolerance: 0 +2)	Test loads (N) for a hole diameter in support plate of:	
	200 mm	150 mm
4	1500	1600
5	2400	2600
6	3400	3500
8	6500	6700
10	10200	11000
12	15500	16500
15	24000	25500
19	33400	36800

Figure 9 : Testing apparatus for punch testing toughened glass panes

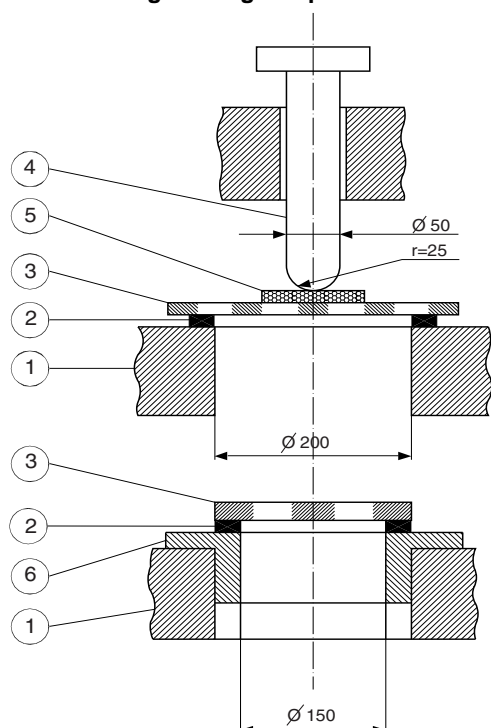

- | | | |
|---|---|---|
| 1 | : | Steel Plate with upper flat surface and rounded edges |
| 2 | : | Rubber ring with IRHD 40 - 60 |
| 3 | : | Glass pane |
| 4 | : | Punch D 50 mm with lower hemispherical part |
| 5 | : | Felt disc 5 mm thickness |
| 6 | : | Adapter for testing glass panes having diameters < 250 mm |

Note 1: Testing equipment

The equipment can be used for glass panes of sidescuttles having nominal diameter 200, 250 mm or greater and for glass of rectangular windows of any size.

The base of the testing equipment is formed by a steel platform with upper flat surface provided with a 200 mm central hole with rounded edges (1); a rubber ring (2), having hardness in the range from 40 to 60 IRHD (International Rubber Hardness Degrees), with an inside diameter of 200 mm, thickness of 2 mm and width of at least 15 mm, located around the hole, between the steel plate and the glass pane, so as to compensate for any slight irregularities of the platform and to prevent the edges of the platform from bearing directly against the glass pane; a suitable adapter provided with a

hole of 150 mm (6) with rounded edges to be used when testing glass panes having a diameter of 200 mm (in these cases, a rubber ring having an inside diameter of 150 mm is to be interposed between the upper surface of the adapter and the glass pane).

The glass pane to be tested (3) is positioned over the hole in the platform and a shaft (4) with a diameter of 50 mm and a fully rounded end is arranged above the glass pane along the axis of the hole.

A felt disk (5) having a thickness of 5mm is arranged between the shaft and the glass pane, for the purpose of distributing the load.

Note 2: Testing procedure

The applied load is to be increased at a rate of 1000 N per second up to the test load specified in Tab 19. The test load is to be maintained for a period of at least 5 seconds and is then to be removed gradually.

The glass panes are to withstand the required test load without fracture.

6.3.3 Visual and dimensional examination

The following examinations are to be performed:

- visual examination
- dimensional and conformity checks to be performed by the Manufacturer, with checks at the discretion of the Surveyor.

6.4 Identification and marking

6.4.1 All glass panes tested with satisfactory results are to be marked by the Manufacturer in a suitable position which remains clearly visible after the glass pane has been installed, as follows:

- trade mark and/or name of the Manufacturer
- Society's brand
- nominal thickness, in mm.

In the case of glass panes tested with the punch test, the special marking mentioned in ISO 614 is to be used as follows:

- transparent glass panes: single line triangle
- matt glass panes: double line triangle.

The nominal thickness of the glass pane, in mm, is to be marked inside the above triangles.

The markings identifying the origin of the glass pane are to be specified to the Society when the individual Manufacturers are recognised.

SECTION 2

VARIOUS FINISHED PRODUCTS

1 Cast copper alloy propellers and propellers blades

1.1 Application

1.1.1 (1/7/2021)

The requirements of this Article are applicable to the manufacture, inspection and repair procedures of cast copper alloy propellers, blades and bosses.

1.1.2 (1/7/2021)

Where the use of alternative alloys is proposed, particulars of chemical composition, mechanical properties and heat treatment are to be submitted for approval.

1.1.3 (1/7/2021)

The requirements of this Article may also be used for the repair of propellers damaged in service, subject to prior agreement with the Society.

1.2 Manufacture

1.2.1 (1/7/2021)

All propellers and propeller components are to be manufactured by foundries approved by the Society; the conditions for approval are indicated in the "Rules for the approval of Manufacturers of materials".

1.2.2 These castings are to be manufactured and tested in accordance with the appropriate requirements of Chapter 1 and Chapter 2 and the specific requirements of this Article.

1.2.3 Pouring (1/7/2021)

The pouring must be made into dried moulds using degassed liquid metal. The pouring is to be controlled so as to avoid turbulences of flow. Special devices and/or procedures must prevent slag flowing into the mould.

1.2.4 Stress relieving (1/7/2021)

Subsequent stress relieving heat treatment may be performed to reduce the residual stresses. For this purpose, the manufacturer shall submit a specification containing the details of the heat treatment to the Society for approval. For stress relieving temperatures and holding times see Tab 4 and Tab 7.

1.3 Quality of castings

1.3.1 Freedom from defects (1/7/2021)

All castings must have a workmanlike finish and are to be free from surface or internal defects which would be prejudicial to their proper application in service. Minor casting defects which may still be visible after machining, such as small sand and slag inclusions, small cold shots and scabs, are to be trimmed off by the Manufacturer in accordance with [1.12].

1.3.2 Removal of defects (1/7/2021)

Casting defects which may impair the serviceability of the castings, e.g. major non-metallic inclusions, shrinkage cavities, blow holes and cracks, are not permitted. They may be removed by one of the methods described in [1.12] and repaired within the limits and restrictions for the severity zones. Full description and documentation are to be available for the surveyor.

1.4 Condition of supply

1.4.1 At the option of the Manufacturer, castings may be supplied in the "as cast" or heat treated condition.

1.5 Dimensions, dimensional and geometrical tolerances

1.5.1 (1/7/2021)

The verification of dimensions, the dimensional and geometrical tolerances is the responsibility of the Manufacturer. The report on the relevant examinations is to be submitted to the Surveyor, who may require checks to be made in his presence.

1.5.2 (1/7/2021)

Static balancing is to be carried out on all propellers in accordance with the approved drawing.

Dynamic balancing is required for propellers running above 500 rpm.

1.6 Chemical composition and metallurgical characteristics

1.6.1 Chemical composition (1/7/2021)

Typical copper propeller alloys are grouped into the four types CU1, CU2, CU3, and CU4 depending on their chemical composition as given in Tab 1. Copper alloys whose chemical composition deviates from the typical values of Tab 1 are to be specially approved by the Society.

1.6.2 The Manufacturer is to maintain records of the chemical analyses of the production casts, which are to be made available to the Surveyor so that he can satisfy himself that the chemical composition of each casting is within the specified limits.

1.6.3 Metallurgical characteristics (1/7/2021)

For copper-based alloys CU1 and CU2, in order to ensure adequate cold ductility and corrosion fatigue resistance, the proportion of beta phase is to be kept low. For this purpose, the zinc equivalent defined by the following formula is not to exceed a value of 45 %:

$$\text{Zinc equivalent (\%)} = 100 - [(100 \times \%Cu / 100 + A)]$$

in which $A = \%Sn + 5 \times \%Al - 0,5 \times \%Mn - 0,1 \times \%Fe - 2,3 \times \%Ni$.

Note 1: The negative sign in front of the element Mn, Fe and Ni signifies that these elements tend to reduce the proportion of beta phase.

The micro structure of alloy types CU 1 and CU 2 is to be verified by determining the proportion of alpha phase. For this purpose, at least one specimen is to be taken from each heat. The proportion of alpha phase is to be determined as the average value of 5 counts.

Note 2: The main constituents of the microstructure in the copper-based alloys categories CU 1 and CU 2 are alpha and beta phase.

Important properties such as ductility and resistance to corrosion fatigue are strongly influenced by the relative proportion of beta phase (too high a percentage of beta phase having a negative effect on these properties).

To ensure adequate cold ductility and corrosion fatigue resistance, the proportion of beta phase is to be kept low. The concept of the zinc equivalent should be used as control since it summarizes the effect of the tendency of various chemical elements to produce beta phase in the structure.

1.6.4 (1/7/2021)

In addition to [1.6.3], the CU1 and CU2 type alloys are to contain an alpha phase component of at least 25%; this is to be checked on a test bar by the Manufacturer.

1.7 Mechanical properties and tests

1.7.1 Standardized alloys (1/7/2021)

The mechanical properties are to comply with the values given in Tab 2.

The values given in Tab 2 are applicable to test specimens taken from separately cast samples in accordance with Fig 1, or with a recognised standard.

It is to be noted that these properties are generally not representative of the mechanical properties of the propeller casting itself, which may be up to 30% lower than that of a separately cast test coupon.

Table 1 : Typical chemical composition of cast copper alloys for propeller and propeller blade (1/7/2021)

Alloy Type	Cu (%)	Sn (%)	Zn (%)	Pb (%)	Ni (%)	Fe (%)	Al (%)	Mn (%)
CU1	52 - 62	max. 1,5	35 - 40	max. 0,5	max. 1,0	0,5 - 2,5	0,5 - 3,0	0,5 - 4,0
CU2	50 - 57	max. 1,5	33 - 38	max 0,5	3,0 - 8,0	0,5 - 2,5	0,5 - 2,0	1,0 - 4,0
CU3	77 - 82	max. 0,1	max. 1,0	max 0,03	3,0 - 6,0	2,0 - 6,0	7,0 - 11,0	0,5 - 4,0
CU4	70 - 80	max. 1,0	max. 6,0	max 0,05	1,5 - 3,0	2,0 - 5,0	6,5 - 9,0	8,0 - 20,0

Table 2 : Mechanical properties of cast copper alloys for propellers and propeller blade castings

Alloy type	Proof stress $R_{p0,2}$ (N/mm ²) min.	Tensile strength R_m (N/mm ²) min.	Elongation A5 (%) min.
CU1	175	440	20
CU2	175	440	20
CU3	245	590	16
CU4	275	630	18

Note 1: The values shown are related to specimens taken from separately cast samples as per Fig 1 or recognised national standards.

Note 2: The 0,2% proof stress values are to be determined for all keyless type propeller castings. For other types of propeller casting, these values are given for information purposes only and, unless expressly required, their determination may be omitted during testing.

1.7.2 Other alloys (1/7/2021)

The mechanical properties of alloys not meeting the minimum values of Tab 2 are to comply with the requirements of the relevant specification to be approved by the Society.

1.7.3 Tensile tests and specimens (1/7/2021)

Tensile tests and specimens are to be in accordance with Ch 1, Sec 2.

Generally, the specimens are to be taken from separately cast sample pieces in accordance with [1.8]. The test samples are to be cast in moulds made of the same material as the mould for the propeller and they are to be cooled down under the same conditions as the propeller. At least one tensile test specimen is to be taken from each ladle.

If propellers are subjected to a heat treatment the test samples are to be heat treated together with them.

Where test specimens are to be taken from integrally cast test samples, this is to be the subject of special agreement with the Society. Wherever possible, the test samples are to be located on the blades in an area lying between 0,5 to 0,6 R, where R is the radius of the propeller. The test sample material is to be removed from the casting by non thermal procedures.

1.8 Sampling and testing

1.8.1 Test samples are to be provided from each cast used for the manufacture of propeller blade casting.

1.8.2 The test samples are to be of keel block type, in accordance with the dimensions in Fig 1, and are to be cast in moulds made from the same type of materials as used for the castings.

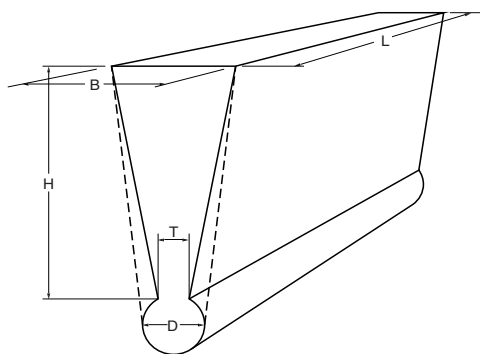
Figure 1 : Keel block test sample casting

H=100mm ; B=50mm ; L>150mm ; T=15mm ; D=25mm

1.8.3 Where castings are supplied in the heat treated condition, the test samples are to be heat treated together with the casting which they represent.

1.8.4 At least one tensile test specimen is to be taken from each ladle.

1.8.5 The results of all tensile tests are to comply with the requirements given in Tab 2.

1.8.6 (1/7/2021)

Metallographic examination of alloy types CU1 and CU2 is to be verified by determining the proportion of alpha phase. For this purpose, at least one specimen is to be taken from each heat. The proportion of alpha phase is to be determined as the average value of 5 counts. The requirements of [1.6.4] are to be fulfilled.

1.9 Inspection, definition of skew and severity zones

1.9.1 Propeller castings are to be cleaned and adequately prepared for inspection.

1.9.2 All finished propellers are to be presented for a comprehensive visual inspection by the Surveyor.

1.9.3 Definition of skew (1/7/2021)

The skew of a propeller is defined as follows:

The maximum skew angle of a propeller blade is defined as the angle, in the projected view of the blade, between a line drawn through the blade tip and the shaft centreline and a second line through the shaft centreline which acts as a tangent to the locus of the mid-points of the helical blade section; see Fig 2.

High skew propellers have a skew angle greater than 25°, low skew propellers a skew angle of up to 25°.

1.9.4 Severity zones (1/7/2021)

For the purpose of the requirements of this Section, in order to relate the degree of inspection to the criticality of defects in propeller blades and to help reduce the risk of failure by fatigue cracking after repair, propellers and propeller blades are divided in order of importance into three severity zones, A, B and C.

Zone A is the region supporting the highest operating stresses and which, therefore, requires the highest degree of inspection. Generally, the blade thicknesses are greatest in this area giving the greatest degree of restraint in repair welds and this in turn leads to the highest residual stresses in and around any repair welds. High residual tensile stresses frequently lead to fatigue cracking during subsequent service so that relief of these stresses by heat treatment is essential for any welds made in this zone. Welding is generally not permitted in Zone A and will only be allowed after special consideration by the Society. Every effort should be made to rectify a propeller which is either defective or damaged in this area without recourse to welding even to the extent of reducing the scantlings, if this is acceptable. If a repair using welding is agreed, postweld stress relief heat treatment is mandatory.

Zone B is a region where the operating stresses may be high. Welding should preferably be avoided but generally is allowed subject to prior approval from the Society. Complete details of the defect / damage and the intended repair procedure are to be submitted for each instance in order to obtain such approval.

Zone C is a region in which the operating stresses are low and where the blade thicknesses are relatively small so that repair welding is safer and, if made in accordance with an approved procedure is freely permitted.

1.9.5 Low-skew propellers (1/7/2013)

Zone A is in the area on the pressure side of the blade, from and including the fillet to 0,4R, and bounded on either side by lines at a distance 0,15 times the chord length C_R from the leading edge and 0,2 times C_R from the trailing edge, respectively (see Fig 3).

Where the hub radius (R_B) exceeds 0,27R, the other boundary of zone A is to be increased to 1,5 R_B .

Zone A also includes the parts of the separate cast propeller hub which lie in the area of the windows as described in Fig 5 and the flange and fillet area of controllable pitch and built-up propeller blades as described in Fig 6.

Zone B is on the pressure side, the remaining area up to 0,7R and on the suction side the area from the fillet to 0,7R (see Fig 3).

Zone C is the area outside 0,7R on both sides of the blade. It also includes the surface of the hub of a mono-block propeller and all the surfaces of the hub of a controllable pitch propeller other than those designated Zone A above.

1.9.6 High-skew propellers (1/7/2013)

Zone A is the area on the pressure face contained within the blade root-fillet and a line running from the junction of the leading edge with the root fillet to the trailing edge at 0,9R and passing through the mid-point of the blade chord at 0,7 R and a point situated at 0,3 of the chord length from the leading edge at 0,4 R. It also includes an area along the trailing edge on the suction side of the blade from the root to 0,9 R and with its inner boundary at 0,15 of the chord length from the trailing edge.

Zone B constitutes the whole of the remaining blade surface.

Zone A and B are illustrated in Fig 4.

Figure 2 : Definition of skew angle

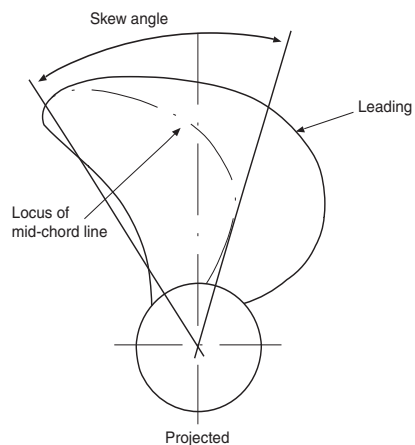

Figure 3 : Severity zones for integrally cast low skew propellers

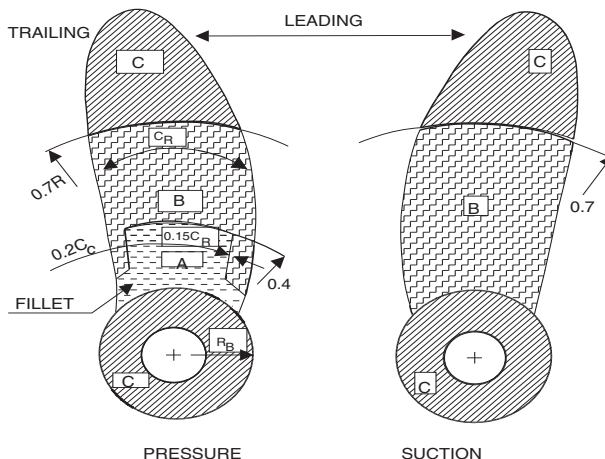

Figure 4 : Severity zones in blades with skew angles > 25°

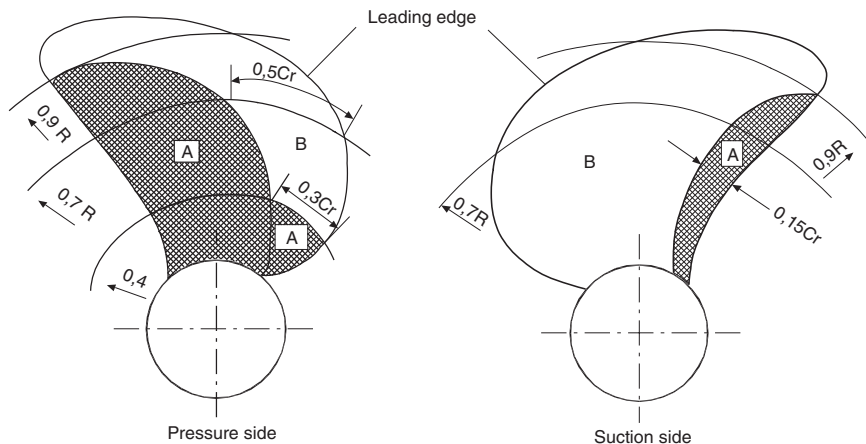
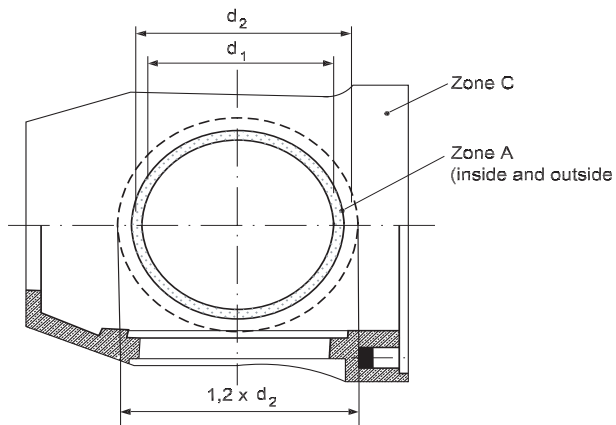
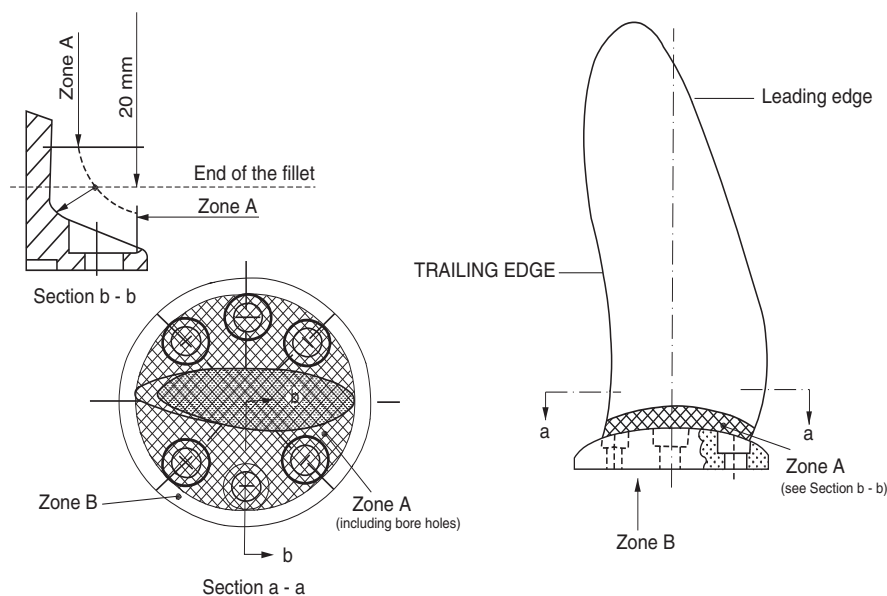

Figure 5 : Severity zones for controllable pitch propeller boss



**Figure 6 : Severity zones
for controllable pitch and built-up propeller**



Note: The remaining surface of the propeller blades of a controllable pitch propeller is to be divided into the severity zones as given for solid cast propellers (cf. Fig 3 and Fig 4)

1.10 Non-destructive testing (NDT)

1.10.1 Qualification of personnel involved in NDT (1/7/2021)

The qualification of personnel involved in NDT is to be in accordance with Ch 1, App 1.

1.10.2 Visual testing (1/7/2021)

All finished castings are to be 100% visually inspected by the manufacturer. Castings are to be free from cracks, hot tears or other imperfections which, due to their nature, degree or extent, will interfere with the use of the castings. A general visual examination is to be carried out by the Surveyor, and this is to include the examination of internal surfaces where applicable.

1.10.3 Liquid penetrant testing (1/7/2021)

Propeller castings are to be cleaned and adequately prepared. The liquid penetrant testing procedure is to be submitted to the Society and is to be in accordance with ISO 3452-1:2013 or a recognised standard. The acceptance criteria are specified in [1.11].

The severity zones A as defined above are to be subjected to a liquid penetrant testing in the presence of the Surveyor.

In zones B and C the liquid penetrant testing is to be performed by the Manufacturer and may be witnessed by the Surveyor upon his request.

If repairs have been made either by grinding, straightening or by welding, the repaired areas are additionally to be subjected to the liquid penetrant testing independent of their location and/or severity zone.

1.10.4 Radiographic and ultrasonic testing (1/7/2021)

When required by the Society or when deemed necessary by the manufacturer, further non-destructive testing (e.g.

radiographic and/or ultrasonic tests,) are to be carried out. The acceptance criteria or applied quality levels are to be agreed between the Manufacturer and the Society in accordance with a recognised standard.

Note 1: due to the attenuating effect of ultrasound within cast copper alloys, ultrasonic testing may not be practical in some cases, depending on the shape/type/thickness, and grain growth direction of the casting. In such cases, effective ultrasound penetration into the casting should be practically demonstrated on the item. This would normally be determined by way of back-wall reflection, and/or target features within the casting.

1.11 Acceptance criteria for liquid penetrant testing

1.11.1 Definitions of liquid penetrant indications (1/7/2021)

For the purpose of this Article the following definitions applies:

Indication: In the liquid penetrant testing an indication is the presence of detectable bleed-out of the penetrant liquid from the material discontinuities appearing at least 10 minutes after the developer has been applied.

Relevant indication: Only indications which have any dimension greater than 1,5mm shall be considered relevant for the categorization of indications.

Non-linear indication: an indication with a largest dimension less than three times its smallest dimension (i.e. $l < 3 w$).

Linear indication: an indication with a largest dimension three or more times its smallest dimension (i.e. $l \geq 3 w$).

Aligned indication:

- Non-linear indications form an alignment when the distance between indications is less than 2mm and at least three indications are aligned. An alignment of indications is considered to be a unique indication and its length is equal to the overall length of the alignment.
- Linear indications form an alignment when the distance between two indications is smaller than the length of the longest indication.

1.11.2 Acceptance standard (1/7/2021)

The surface is to be divided into reference areas of 100 cm². Each reference area may be square or rectangular with the major dimension not exceeding 250mm. The area is to be taken in the most unfavourable location relative to the indication being evaluated.

The relevant indications detected are to, with respect to their size and number, not exceed the values given in the Tab 3.

In addition to the above acceptance criteria, small defects, such as pores less than 1 mm in diameter, may generally be disregarded except where they occur in closely spaced groups.

Illustration of liquid penetrant indication is given in Fig 7.

Figure 7 : Shape of indications (1/7/2021)

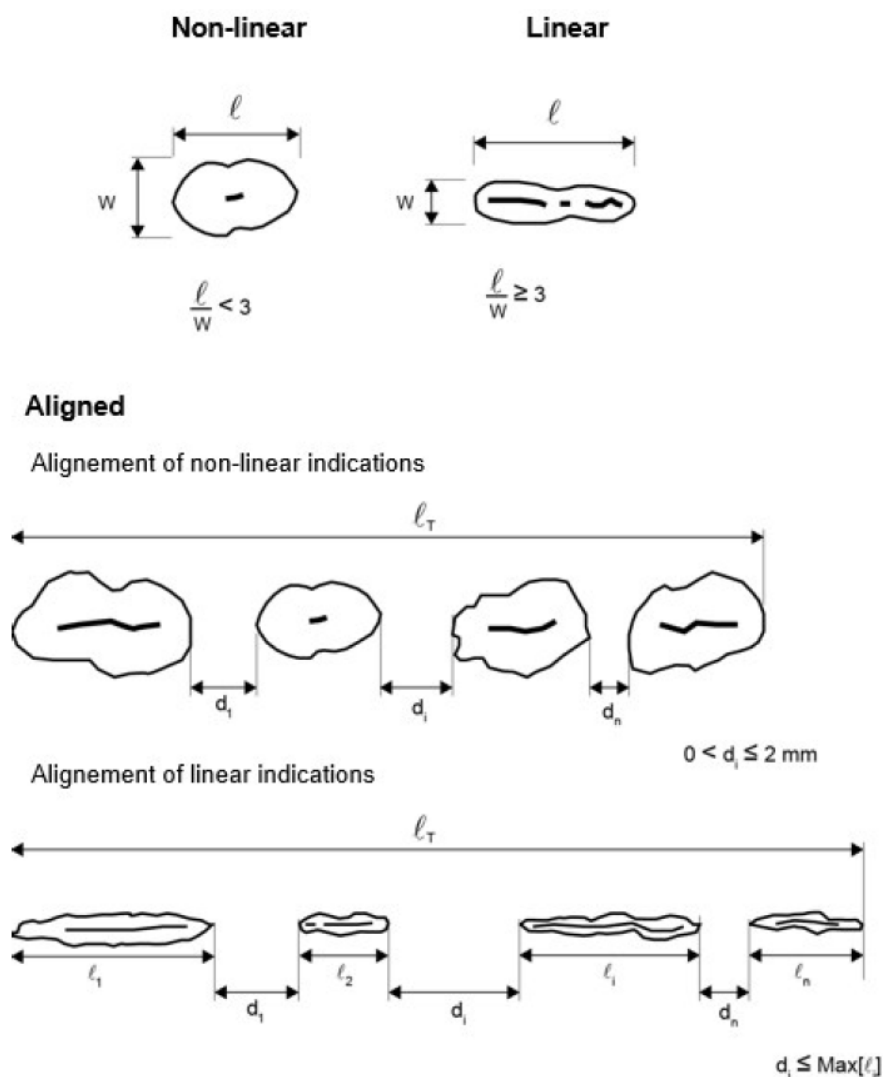

Table 3 : Allowable number and size of relevant indications in a reference area of 100 cm² depending on severity zones(1) (1/7/2021)

Severity zones	Max. total number of indications	Type of indication	Max. number of each type (1) (2)	Max. acceptable value for "a" or "l" of indications, in mm
A	7	Non-linear	5	4
		Linear	2	3
		Alligned	2	3
B	14	Non-linear	10	6
		Linear	4	6
		Alligned	4	6
C	20	Non-linear	14	8
		Linear	6	6
		Alligned	6	6

(1) Singular non-linear indications less than 2 mm for zone A and less than 3 mm for the other zones are not considered relevant.
(2) The total number of non-linear indications may be increased to the maximum total number, or part thereof, represented by the absence of linear or aligned indications.

Areas which are prepared for welding are independent of their location always to be assessed according to zone A. The same applies to the welded areas after being finished machined and/or grinded.

1.12 Repair of defects

1.12.1 General (1/7/2021)

Indications exceeding the acceptance standard of items Tab 3, cracks, shrinkage cavities, sand, slag and other non-metallic inclusions, blow holes and other discontinuities which may impair the safe service of the propeller are defined as defects and are to be repaired.

1.12.2 Repair procedures (1/7/2021)

In general the repairs are to be carried out by mechanical means, e.g. by grinding, chipping or milling. Welding may be applied, subject to the agreement of the Society, if the relevant requirements detailed hereafter are satisfied.

1.12.3 (1/7/2021)

After milling or chipping, grinding is to be applied for such defects which are not to be welded. Grinding is to be carried out in such a manner that the contour of the ground depression is as smooth as possible in order to avoid stress concentrations or to minimize cavitation corrosion. Complete elimination of the defective material is to be verified by liquid penetrant testing.

1.12.4 (1/7/2007)

Localised pores on the end face or bore of a propeller boss, which themselves do not affect the strength of the casting, can be filled with a suitable plastic filler after the appropriate preparation of the defective area. The foundry is to keep records and details of all castings which have been rectified.

1.12.5 Repair of defects in zone A (1/7/2021)

In zone A, repair welding will generally not be allowed unless specially approved by the Society.

In some cases the propeller designer may submit technical documentation to propose a modified zone A based on detailed hydrodynamic load and stress analysis for consideration by the Society.

Grinding can be carried out to an extent which maintains the blade thickness of the approved drawings.

The possible repair of defects which are deeper than those referred to above will be specially considered by the Society.

1.12.6 Repair of defects in zone B (1/7/2021)

In zone B, defects that are not deeper than $d_B = (t/40)$, in mm (where t is the minimum local thickness in mm according to the Rules) or 2 mm, whichever is the greater, are to be removed by grinding. Those defects that are deeper than allowable for removal by grinding may be repaired by welding.

1.12.7 Repair of defects in zone C (1/7/2021)

In zone C, repair welds are generally permitted.

1.12.8 (1/7/2007)

All weld repairs are to be documented by means of sketches or photographs showing the location and major dimensions of the grooves prepared for welding. Weld repairs are to be undertaken only when they are considered to be necessary and with the prior agreement of the Surveyor. Welding of areas less than 5 cm² and depths of less than 2 mm is to be avoided.

1.12.9 Welding repair procedure (1/7/2021)

Before welding is started, Manufacturer is to prepare and submit to the Society a detailed welding procedure specification covering the weld preparation, welding position,

welding parameters, filler metals, preheating and post-weld heat treatment and inspection procedures.

All weld repairs are to be carried out in accordance with qualified procedures, and, by welders who are qualified to a recognized standard. Welding Procedure Qualification Tests are to be carried out in accordance with Ch 5, Sec 4, [7] and witnessed by the Surveyor.

Defects to be repaired by welding are to be ground to sound material according to [1.12.3].

The welding grooves are to be prepared in such a manner which will allow a good fusion of the groove bottom.

The resulting ground areas are to be examined in the presence of the Surveyor by liquid penetrant testing in order to verify the complete elimination of defective material.

Metal arc welding is to be used for all types of welding repair on cast copper alloy propellers.

Arc welding with coated electrodes and gas-shielded metal arc process (GMAW) are generally to be applied. Argon-shielded tungsten welding (GTAW) should be used with care due to the higher specific heat input of this process.

Recommended filler metals, pre-heating and stress relieving temperatures are listed in Tab 4.

All propeller alloys are generally to be welded in the down-hand (flat) position. Where this cannot be done, gas-shielded metal arc welding should be carried out.

The section to be welded is to be clean and dry. Flux-coated electrodes are to be dried before welding according to the maker's instructions.

To minimize distortion and the risk of cracking, interpass temperatures are to be kept low.

This is especially the case with CU 3 alloys.

Slag, undercuts and other defects are to be removed before depositing the next run.

All welding work is to be carried out in a shop free from draughts and adverse weather.

With the exception of alloy type CU 3 castings, all weld repairs are to be stress relief heat treated, in order to avoid stress corrosion cracking. However, stress relief heat treatment of alloy type CU 3 castings is required after major repairs in zone B (and zone A when specially approved) or if a welding consumable depositing a metal susceptible to stress corrosion cracking is used (e.g. with chemical composition of alloy type CU 4).

In such cases, the propeller is to be either stress relief heat treated in the temperature range 450 to 500°C or annealed in the temperature range 650-800°C, depending on the extent of repair (see Tab 4).

The Soaking times are to be in accordance with Tab 5. The heating and cooling are to be suitably controlled to minimize residual stresses. The cooling rate after any stress relieving heat treatment is not to exceed 50°C/h until a temperature of 200°C is reached.

Table 4 : Recommended filler metals and heat treatments (1/7/2013)

Alloy type	Filler metal	Preheat temperature °C [min]	Interpass temperature °C [max]	Stress relief temperature °C	Hot straightening temperature °C
CU1	Al-bronze (1) Mn-bronze	150	300	350-500	500-800
CU2	Al-bronze Ni-Mn-bronze	150	300	350-550	500-800
CU3	Al-bronze Ni-Al-bronze (2) Mn-Al-bronze	50	250	450-500	700-900
CU4	Mn-Al-bronze	100	300	450-600	700-850
(1) Ni-Al-bronze and Mn-Al-bronze are acceptable.					
(2) Stress relieving not required, if filler metal Ni-Al-bronze is used.					

Table 5 : Soaking times for stress relief heat treatment of copper alloy propellers (1/7/2021)

Stress relief temperature (°C)	Alloy Grade CU 1 and CU 2		Alloy Grade CU 3 and CU 4	
	Hours per 25 mm of thickness	Maximum recommended total hours	Hours per 25 mm of thickness	Maximum recommended total hours
350	5	15	-	-
400	1	5	-	-
450	1/2	2	5	15
500	1/4	1	1	5
(1) 550°C and 600°C applicable to CU 4 alloys only.				

Stress relief temperature (°C)	Alloy Grade CU 1 and CU 2		Alloy Grade CU 3 and CU 4	
	Hours per 25 mm of thickness	Maximum recommended total hours	Hours per 25 mm of thickness	Maximum recommended total hours
550	1/4	1/2	1/2 (1)	2 (1)
600	-	-	1/4 (1)	1 (1)

(1) 550°C and 600°C applicable to CU 4 alloys only.

1.12.10 (1/7/2021)

Areas which are prepared for welding are to be subjected to liquid penetrant testing and, irrespective of their location, they are always to be assessed in accordance with criteria for zone A.

1.12.11 (1/7/2007)

The area of any single repair and the maximum total area in any zone or region are generally to be kept within the following limits, where S, in cm², is the blade area surface or, for zones outside the blades, the area of the relevant zone (here after "other zones"):

- Zone A: no repairs
- Zone B and C, single: 0,006S or 60cm², whichever is the greater
- Zone B (leading edge), total: 0,008S or 100cm², whichever is the greater
- Zone B+C, total: 0,02S or 200cm², whichever is the greater
- Other zone, single area: 0,015S or 20cm², whichever is the greater
- Other zones, total for each zone: 0,05S or 50cm², whichever is the greater. Other zones means in particular the following surfaces:
 - a) for integrally cast propellers:
 - within the bore
 - outer surfaces of the boss to the start of the fillet radius
 - forward and aft end faces of the boss
 - b) for separately cast propeller blades:
 - surfaces of the flange to the start of the fillet radius.

Where repairs exceeding the above limits are proposed, their type, procedure and extent are to be individually examined by the Society before commencement of the repair, and any conditions will be specified.

1.12.12 (1/7/2021)

Metal arc welding with electrodes or filler wire used in the qualification procedure tests is to be employed. The welding consumables are to be stored and handled in accordance with the Manufacturer's recommendations. The grooves prepared for welding are to be ground smooth and complete elimination of the defective material is to be verified by liquid penetrant testing. Slag, undercuts and other imperfections are to be removed before depositing the next run.

1.12.13 (1/7/2021)

Stress relief heat treatment is to be within the temperature range given in Tab 4.

1.12.14 (1/7/2021)

When welding operations, including stress relief heat treatment, are completed, welded areas in finished machined and/or grinded condition are to be subjected to visual inspection and liquid penetrant testing and assessed in accordance with criteria for zone A.

1.12.15 Repair documentation (1/7/2021)

The foundry is to maintain records of inspections, welding and any subsequent heat treatment traceable to each casting. These records are to be available for review by the Surveyor and copies are to be handed over to the Surveyor upon his request.

Before welding is started, full details of the extent and location of the repair, the proposed welding procedure, heat treatment and subsequent inspection procedures are to be submitted to the Society for approval.

1.13 Straightening

1.13.1 Application of load

For hot and cold straightening purposes, static loading only is to be used.

1.13.2 Hot straightening (1/7/2021)

Weld repaired areas may be subject to hot straightening, provided it can be demonstrated that weld properties are not impaired by the hot straightening operations.

Hot straightening of a bent propeller blade or a pitch modification is to be carried out after heating the bent region and approximately 500 mm wide zone on either side of it to the suggested temperature range given in Tab 4.

The heating is to be slow and uniform and concentrated flames, such as oxyacetylene and oxy-propane, are not to be used. Sufficient time is to be allowed for the temperature to become fairly uniform through the full thickness of the blade section. The temperature is to be maintained within the suggested range throughout the straightening operation. A thermocouple instrument or temperature indicating crayons is/are to be used for measuring the temperature.

1.13.3 Cold straightening (1/7/2021)

Cold straightening is to be used for minor repairs of tips and edges only. Cold straightening on castings made of alloy type CU 1, CU 2 and CU 4 are always to be followed by a stress relief heat treatment; see Tab 7.

1.14 Identification and marking

1.14.1 Identifications (1/7/2021)

The Manufacturer is to adopt a system for the identification of all castings, which will enable the material to be traced

back to its original cast. On request, the Surveyor is to be given full facilities for so tracing the castings.

1.14.2 Marking (1/7/2021)

In addition to the indications required in Ch 1, Sec 1, [4.1.1], each finished casting propeller which have been tested and inspected with satisfactory results is to be marked by the manufacturer at least with the following details:

- a) Manufacturer's mark
- b) grade of cast material or corresponding abbreviated designation
- c) heat number, casting number or another mark enabling the manufacturing process to be traced back
- d) date of final inspection
- e) number of the Society's test certificate
- f) ice class symbol, where applicable
- g) skew angle for high skew propellers.

1.15 Manufacturer's certificates

1.15.1 (1/7/2013)

For each propeller, the Manufacturer is to supply the Surveyor with a certificate containing the following details:

- a) purchaser and order number
- b) shipbuilding project number, if known
- c) description of casting with drawing number
- d) diameter, number of blades, pitch, direction of turning
- e) grade of alloy and chemical composition of each heat
- f) heat or casting number
- g) final weight
- h) results of non-destructive tests and details of test procedure, where applicable
- i) portion of alpha-structure for CU1 and CU2 alloys
- j) results of the mechanical tests
- k) casting identification number
- l) skew angle for high skew propellers; see [1.9.3].

2 Pressure bottles

2.1 Application

2.1.1 General

The requirements of this Article apply to seamless pressure bottles in carbon, carbon manganese and alloy steels, and to welded bottles in carbon and carbon manganese steels.

Seamless bottles are mainly used for carbon dioxide systems and welded bottles for portable fire extinguishers.

Steel grades to be used for the manufacture are to comply with those specified in Chapter 2 as applicable or with recognised standards.

The steel is to be killed and for certain applications, for example low temperature applications, fine grained steel is to be used.

2.1.2 Mass production

In the case of small bottles mass produced by Manufactures who have been approved by the Society for this purpose, alternative testing procedures to those indicated in [2.3.1] may be accepted.

2.1.3 Materials other than steel

The requirements relevant to bottles in material other than steel are to be considered on a case-by-case basis, with criteria and procedures as similar as possible to those specified in this Article.

2.2 Manufacture

2.2.1 Bottles are to be manufactured according to approved plans.

The manufacturing process of seamless bottles is to be approved for the individual Manufacturers.

The approval of the manufacturing process is also required for welded bottles intended for portable fire extinguishers having thickness of the cylindrical shell less than 3 mm.

Provisions for approval are given in the document, "Rules for the Approval of Manufacturers of Materials".

The materials used in the bottle manufacture are to be tested or provided with a Manufacturer's certificate of conformity.

2.3 Inspection and tests

2.3.1 General

The following inspections and tests are to be performed:

- a) sectioning of one bottle from each batch formed of 200 pieces or fraction thereof, homogeneous as regards dimensions, manufacturing process and heat treatment for the execution of :
 - thickness measurements of the shell on three transverse sections in way of neck, middle and bottom end
 - 1 tensile test on longitudinal test specimen, 2 bending tests to be performed along the curvature and, for thicknesses ≥ 5 mm, 3 Charpy V-notch impact tests on longitudinal specimens, to be performed at -20°C . For low temperature applications, the test temperature is to be specified in the individual cases.
- b) hardness tests to be performed on bottles of quenched and tempered steel and, at the discretion of the Surveyor, also in other cases
- c) external and internal visual examination (direct examination or, in the case of insufficient size of openings, examination by auxiliary means), dimensional check, determination of tare and capacity (such examinations

are to be performed by the Manufacturer with checks at the Surveyor's discretion)

- d) hydrostatic test on each bottle; test pressure as required by the relevant Rules or by the particular requirements applicable in the individual cases
- e) non-destructive checks as indicated on the plans at the time of the approval of the manufacturing process
- f) for welded bottles, additional tests on welded joints as specified at the time of the approval of the manufacturing process or indicated on the approved plans.

2.3.2 Tensile test

In the tensile test, the values of the yield strength R_{eH} and $R_{p0.2}$, the tensile strength R_m and the elongation A (%) are to comply with the values specified for the corresponding steel.

The value of A (%) min, for thicknesses equal to or greater than 3 mm, is to be not less than the value calculated with the following formula, and in no case less than 14% :

$$A \geq \frac{2500}{0,224 \cdot R_m}$$

where R_m is the value, in N/mm², of the tensile strength determined by the tensile test.

This requirement for A (%) min may be reduced by 15% for thicknesses less than 3 mm down to 2 mm, and by 30% for thicknesses less than 2 mm.

2.3.3 Bend test

In the bending test, the angle to which the specimen is to be bent without showing defects is 180°; a mandrel having a diameter not exceeding "n" times the thickness of the specimen, depending on the minimum specified tensile strength R_m for the steel, as specified in Tab 8, is to be used.

Table 6 : Coef. n for determination of the max. allowed mandrel diameter in bend test

R_m (N/mm ²)	n
≤ 430	2
431 - 510	3
511 - 590	4
591 - 690	5
691 - 790	6
791 - 890	7
> 890	8

2.3.4 Impact test

In the Charpy V-notch impact test, the value of the absorbed energy, determined as an average of three tests, is to be not less than the value indicated in Tab 9 depending on the minimum tensile strength of the steel.

Table 7 : Impact test - requirements

Steel types	Tensile strength (N/mm ²)	Average impact energy at -20°C min. KV (J/cm ²)
Carbon and carbon- manganese	≤ 510	34
Alloy steels quenched and tempered	> 510	49

2.4 Identification, marking and certification

2.4.1 The Manufacturer is to adopt a system of identification which will enable all finished bottles to be traced to the original materials and their manufacturing.

All bottles which have been tested and inspected with satisfactory results are to be marked with the following details:

- a) Manufacturer's name or trade mark
- b) Society's brand
- c) place and date of testing
- d) production number or other marking enabling the traceability
- e) test pressure
- f) additional optional marks such as file number and code of the local inspection office, Surveyor's personal stamp.

Special marking and certification procedures may be agreed upon for supplies by Manufacturers granted the use of an alternative testing procedure.

2.4.2 The testing documentation indicated in Ch 1, Sec 1, [4.2.1] is required and is to include all the information, as appropriate.

The testing or works' certificate of the material used is to be enclosed with the testing documentation.

Where applicable, the reports relevant to the non-destructive examination, pressure test and heat treatment are to be enclosed with the testing documentation.

2.4.3 Before signing the Society's inspection certificate, the Surveyor is to be provided by the Manufacturer with a written declaration stating that the bottles have been manufactured by a process approved by the Society, they comply with the applicable requirements and they have been satisfactorily tested in accordance with the Society's Rules.

3 Cast steel propellers and propeller blades

3.1 Application

3.1.1 (1/7/2021)

The requirements of this Article are applicable to the manufacture, inspection and repair procedure of cast steel propellers, blades and bosses.

3.1.2 (1/1/2001)

Where the use of alternative alloys is proposed, particulars of chemical composition, mechanical properties and heat treatment are to be submitted for approval.

3.1.3 (1/1/2001)

These requirements may also be used for the repair and inspection of propellers which become damaged during service, subject to prior agreement with the Society.

3.2 Manufacture**3.2.1 (1/7/2021)**

All propellers and propeller components are to be manufactured by foundries approved by the Society; the conditions for approval are indicated in the "Rules for the approval of Manufacturers of materials".

3.2.2 (1/1/2001)

These castings are to be manufactured and tested in accordance with the appropriate requirements of Chapter 1 and Chapter 2 and the specific requirements of this Article.

3.3 Quality of castings**3.3.1 Freedom from defects (1/7/2021)**

All castings are to have a workmanlike finish and are to be free from surface and internal defects which would be prejudicial to their proper application in service.

Minor casting defects which may still be visible after machining such as small sand and slag inclusions, small cold shuts and scabs shall be trimmed off by the manufacturer in accordance with [3.12].

3.3.2 Removal of defects (1/7/2021)

Casting defects which may impair the serviceability of the castings, e.g. major non-metallic inclusions, shrinkage cavities, blow holes and cracks, are not permitted. They may be removed by one of the methods described in [3.12] and repaired within the limits and restrictions for the severity zones. Full description and documentation is to be available for the surveyor.

3.4 Condition of supply**3.4.1 (1/1/2001)**

Martensitic castings are to be supplied in the austenitized and tempered condition. Austenitic castings are to be solution treated.

3.5 Dimensions, dimensional and geometrical tolerances**3.5.1 (1/7/2021)**

The verification of dimensions, the dimensional and geometrical tolerances is the responsibility of the Manufacturer. The report on the relevant examinations is to be submitted to the Surveyor, who may require checks to be made in his presence.

3.5.2 (1/7/2021)

Static balancing is to be carried out on all propellers in accordance with the approved drawings.

Dynamic balancing may be necessary for propellers running above 500 rpm.

3.6 Chemical composition**3.6.1 (1/7/2021)**

Typical cast steel propeller alloys are grouped into four types depending on their chemical composition as given in Tab 10.

Table 8 : Typical chemical composition of steel propeller castings

Alloy type	C Max. (%)	Mn Max. (%)	Cr (%)	Mo (1) Max. (%)	Ni (%)
Martensitic (12Cr 1Ni)	0,15	2,0	11,5-17,0	0,5	Max. 2,0
Martensitic (13Cr 4Ni)	0,06	2,0	11,5-17,0	1,0	3,5-5,0
Martensitic (16Cr 5Ni)	0,06	2,0	15,0-17,5	1,5	3,5-6,0
Austenitic (19Cr 11Ni)	0,12	1,6	16,0-21,0	4,0	8,0-13,0
(1) Minimum values are to be in accordance with recognised national or international standards					

Cast steel whose chemical composition deviate from the typical values of Tab 8 is to be specially approved by the Society.

The Manufacturer is to maintain records of the chemical analyses of the production casts, which are to be made available to the Surveyor so that he can satisfy himself that the chemical composition of each casting is within the specified limits.

3.7 Mechanical properties**3.7.1 (1/7/2021)**

The requirements relevant to the mechanical properties are shown in Tab 11. These values refer to the test specimens machined from integrally cast test bars attached to the hub or on the blade. The thickness of test coupon is to be in accordance with a recognized standard.

Table 9 : Mechanical Properties for steel propeller castings

Alloy type	Proof stress $R_{p0,2}$ min. (N/mm ²)	Tensile strength R_m min. (N/mm ²)	Elongation A_5 min. (%)	Red. of area Z min. (%)	Charpy V-notch (1) Energy min. (J)
12Cr 1Ni	440	590	15	30	20
13Cr 4Ni	550	750	15	35	30
16Cr 5Ni	540	760	15	35	30
19Cr 11Ni	180 (2)	440	30	40	-
(1) Tests to be made at -10°C for Ice Class Notations IAS, IA and IB only					
(2) $R_{p1,0}$ value is 205 N/mm ²					

Where possible, the test bars attached on the blades are to be located in an area lying between $0,5$ to $0,6R$, where R is the radius of the propeller.

The test bars are not to be detached from the castings until the final heat treatment has been carried out. Removal is to be by non-thermal procedures.

3.7.2 (1/1/2001)

Separately cast test bars may be used subject to the prior approval of the Society. The test bars are to be cast from the same heat as the castings represented and heat treated with the castings which they represent.

3.8 Sampling

3.8.1 (1/1/2001)

At least one set of mechanical tests according to Ch 1, Sec 2, [2.1.3] is to be made on material representing each casting.

3.8.2 (1/7/2021)

As an alternative to [3.8.1], where a number of small propellers of about the same size, and less than 1m in diameter, are made from one cast and heat treated in the same furnace charge, a batch testing procedure may be adopted using separately cast test samples of suitable dimensions. At least one set of mechanical tests is to be provided for each multiple of five castings in the batch.

3.9 Definition of skew, severity zones

3.9.1 (1/7/2021)

In order to relate the degree of inspection to the criticality of imperfections in propeller blades and to help reduce the risk of failure by fatigue cracking after repair, propeller blades are divided into three Severity Zones designated A, B and C. In addition, a distinction is made between low skew and high skew propellers as defined in [1.9].

3.10 Non-destructive testing

3.10.1 Qualification of personnel involved in NDT (1/7/2021)

Refer to Ch 1, App 1.

3.10.2 Visual testing (1/7/2021)

All finished castings are to be 100% visually inspected by the Manufacturer.

Castings are to be free from cracks, hot tears or other imperfections which, due to their nature, degree or extent, will interfere with the use of the castings. A general visual examination is to be carried out by the Surveyor.

3.10.3 Liquid penetrant testing (1/7/2021)

Liquid penetrant testing procedure is to be submitted to the Society and is to be in accordance with ISO 3452-1:2013 or a recognized standard. The acceptance criteria are specified in [3.11].

For all propellers, separately cast blades and hub, the surface covered by severity Zones A, B and C are to be liquid penetrant tested. Testing of Zone A is to be undertaken in the presence of the Surveyor. In Zones B and C the liquid

penetrant inspection is to be performed by the Manufacturer and may be witnessed by the Surveyor at his request.

If repairs have been made by grinding or by welding, the repaired areas are additionally to be subjected to liquid penetrant testing irrespective of their location and/or severity zone. Weld repairs are, irrespective of their location, always to be assessed according to Zone A.

3.10.4 Magnetic particle testing (1/7/2021)

Magnetic particle testing may be used in lieu of liquid penetrant testing for examination of martensitic stainless steels castings.

Magnetic particle testing procedure is to be submitted to the Society and is to be in accordance with ISO 9934-1:2016 or a recognized standard.

3.10.5 Radiographic and ultrasonic testing (1/7/2021)

When required by the Society or when deemed necessary by the manufacturer, further non-destructive testing (e.g. radiographic and/or ultrasonic testing) are to be carried out. The acceptance criteria or applied quality levels are then to be agreed between the manufacturer and the Society in accordance with a recognized standard.

Note 1: due to the attenuating effect of ultrasound within austenitic steel castings, ultrasonic testing may not be practical in some cases, depending on the shape/type/thickness, and grain-growth direction of the casting.

3.11 Acceptance criteria for liquid penetrant testing and magnetic particle testing

3.11.1 Definitions of liquid penetrant indications (1/7/2021)

For the purpose of this Article the following definitions applies:

Indication: in the liquid penetrant testing an indication is the presence of detectable bleed-out of the penetrant liquid from the material discontinuities appearing at least 10 minutes after the developer has been applied.

Relevant indication: only indications which have any dimension greater than 1.5mm are to be considered relevant for the categorization of indications.

Non-linear indication: an indication with a largest dimension less than three times its smallest dimension (i.e. $l < 3 w$);

Linear indication: an indication with a largest dimension three or more times its smallest dimension (i.e. $l \geq 3 w$).

Aligned indications:

- Non-linear indications form an alignment when the distance between indications is less than 2mm and at least three indications are aligned. An alignment of indications is considered to be a unique indication and its length is equal to the overall length of the alignment.
- Linear indications form an alignment when the distance between two indications is

smaller than the length of the longest indication.

Illustration of liquid penetrant indications is given in Fig 7.

3.11.2 Acceptance standard (1/7/2021)

The surface to be inspected is to be divided into reference areas of 100 cm², which may be square or rectangular with the major dimension not exceeding 250 mm.

The area is to be taken in the most unfavourable location relative to the indication being evaluated.

With respect to their size and number, the indications detected are not to exceed the values given in Tab 10.

Areas which are prepared for welding are independent of their location always to be assessed according to zone A. The same applies to the welded areas after being finished machined and/or grinded.

3.12 Repair of defects

3.12.1 (1/7/2021)

Defective castings are to be repaired in accordance with the requirements given in [3.12.2] to [3.12.7] and, where applicable, the requirements given in [3.12.8].

3.12.2 (1/7/2021)

In general the repairs are to be carried out by mechanical means, e.g. by grinding, chipping or milling. The resulting grooves are to be blended into the surrounding surface so as to avoid any sharp contours. The local surface is to be subsequently subjected to liquid penetrant testing or magnetic particle testing, if applicable, to ensure that the defects have been completely eliminated.

3.12.3 (1/7/2021)

Weld repairs are to be carried out only where deemed necessary and accepted by the Surveyor.

3.12.4 (1/1/2001)

The weld grooves are to be suitably shaped to allow good access for welding and ground smooth, and complete elimination of the defective material is to be verified by liquid penetrant testing. Welds having an area less than 5 cm² are to be avoided.

3.12.5 (1/7/2021)

Repair by grinding in Severity zone A is allowed to an extent to maintain the required thickness of the blade.

In Zone A, repairs by welding are in general not permitted unless specially considered by the Society.

Therefore where such a repair is proposed, the extent and procedure are to be submitted in detail for acceptance.

In some cases the propeller designer is to submit technical documentation to propose a modified zone A based on

detailed hydrodynamic load and stress analysis for consideration by the Society.

3.12.6 (1/7/2021)

Defects in severity zone B that are not deeper than $t/40$ ("t" is the minimum local thickness according to the Rules) or 2 mm, whichever is the greater, are to be removed by grinding. Defects that are deeper may be repaired by welding subject to the prior approval of the Society.

3.12.7 (1/7/2021)

Repair by welding is generally permitted in Severity zone C.

3.12.8 Welding repair procedure (1/7/2021)

Before welding is started, Manufacturer is to submit to the Classification Society a detailed welding procedure specification covering the weld preparation, welding positions, welding parameters, filler metals, welding consumables, preheating, post-weld heat treatment and inspection procedures.

All weld repairs are to be carried out in accordance with qualified procedures, and, by welders who are qualified to a recognized standard. Welding Procedure Qualification Tests are to be carried out in accordance in Ch 5, Sec 4 and witnessed by the Surveyor.

Defects to be repaired by welding are to be ground to sound material according to [3.11].

The welding grooves are to be prepared in such a manner which will allow a good fusion of the groove bottom.

The resulting ground areas are to be examined in the presence of the Surveyor by liquid penetrant testing in order to verify the complete elimination of defective material.

All welding work is to be carried out in a shop free from draughts and influence of the weather.

The metal arc welding with electrodes or filler wire used in the procedure tests is to be used. The welding consumables are to be stored and handled in accordance with the Manufacturer's recommendations.

Slag, undercuts and other imperfections are to be removed before depositing the next run.

The martensitic steels are to be furnace re-tempered after weld repair. Subject to prior approval, however, local stress relieving may be considered for minor repairs.

On completion of heat treatment the weld repairs and the adjacent material are to be ground smooth. All weld repairs are to be submitted to liquid penetrant testing.

Table 10 : Allowable number and size of indications depending on severity zones

Severity zone	Max. total number of indications	Indication type	Max. number for each type (1) (2)	Max. dimension of indication (mm)
A	7	Non - linear	5	4
		Linear	2	3
		Aligned	2	3
B	14	Non - linear	10	6
		Linear	4	6
		Aligned	4	6
C	20	Non - linear	14	8
		Linear	6	6
		Aligned	6	6

(1) Single non-linear indications less than 2mm in Zone A and less than 3mm in other zones may be disregarded.
(2) The total number of non-linear indications may be increased to the maximum total number, or part thereof, represented by the absence of linear or aligned indications.

3.12.9 Repair documentation (1/7/2021)

The foundry is to maintain records of inspections, welding and any subsequent heat treatment, traceable to each casting.

Before welding is started, full details of the extent and location of the repair, the proposed welding procedure, heat treatment and subsequent inspection procedures are to be submitted to the Society for approval.

3.13 Identification and marking**3.13.1 (1/7/2021)**

The Manufacturer is to adopt a system for the identification of all castings, which enable the material to be traced to its original cast. The Surveyor is to be given full facilities for so tracing the castings when required. Each finished casting propeller is to be marked by the Manufacturer at least with the following particulars:

- Manufacturer's mark
- grade of cast material or corresponding abbreviated designation
- heat number, casting number or another mark enabling the full history of the casting to be traced back
- number of the Society's certificate
- ice class symbol where applicable
- skew angle for high skew propellers.

3.13.2 (1/1/2001)

When the casting has been accepted the Society stamp is to be put on with the date of the final inspection of the casting.

3.14 Document and certification**3.14.1 (1/7/2021)**

The Manufacturer is to supply the Surveyor with an inspection certificate containing the following details for each casting which has been accepted:

- Purchaser's name and order number
- shipbuilding or ship identification, if known
- description of the casting with drawing number
- diameter, number of blades, pitch, direction of turning
- type of alloy, heat number and chemical composition
- casting identification number
- final weight
- skew angle for high skew propellers
- details of time and temperature of heat treatment
- results of mechanical tests

3.14.2 (1/7/2021)

The Manufacturer is to provide a statement of the results of non-destructive tests and details of test procedures and, where applicable, records of weld repairs as required by [3.12.9].

Part D
Materials and Welding

Chapter 5
WELDING

- SECTION 1 GENERAL REQUIREMENTS**
- SECTION 2 APPROVAL OF WELDING CONSUMABLES**
- SECTION 3 APPROVAL OF OVER WELDABLE SHOP PRIMERS**
- SECTION 4 APPROVAL OF WELDING PROCEDURES**
- SECTION 5 APPROVAL OF CO₂ LASER WELDING PROCEDURES**
- SECTION 6 QUALIFICATION SCHEME FOR WELDERS OF HULL STRUCTURAL STEELS**

SECTION 1

GENERAL REQUIREMENTS

1 Application

1.1 General

1.1.1 (1/7/2022)

This Section specifies the general requirements for fabrication by welding, and the other Sections of the Chapter concern the requirements for approval of welding consumables (Sec 2), over weldable shop primers (Sec 3) and welding procedures (Sec 4 and Sec 5).

In the case of applications involving the storage and transport of liquefied gases in bulk and the use of gases or other low-flashpoint fuels, the additional requirements in Ch 2, App 6 apply.

1.1.2 The requirements are essentially intended for the welding of weldable steels and aluminium alloy grades covered by the applicable Articles of this Part D.

1.1.3 Different materials, applications and procedures, as well as other standards and specifications, may be considered by the Society on a case-by-case basis.

2 Fabrication by welding

2.1 General

2.1.1 Fabrication by welding is to be carried out in compliance with the applicable Society Rules and according to normal good practice, general or specific to the individual processes, to the Surveyor's satisfaction; in particular the conditions stated at the time of approval and authorisation for the use of individual processes are to be complied with.

The welded structures, the relevant details and the size of welds are to comply with the applicable requirements; any other requirements indicated on the approved plans or specified during survey of construction are also to be complied with.

2.2 Approval

2.2.1 Plans

The constructional plans are to be submitted for approval when required by the Rules or in individual cases and are to contain the necessary data relevant to the fabrication by welding of the structures and items represented. In particular, material types, welding details, welding processes and weld size are to be indicated; any details not represented in the plans are, in any case, to comply with the applicable requirements.

2.2.2 Welding procedures and consumables

Welding to be used in hull construction, machinery, pressure systems and equipment subject to the inspection of the

Society, is to be carried out with approved welding consumables and in accordance with approved welding procedures.

2.2.3 Welders (1/1/2018)

Welders for manual welding and for semiautomatic welding processes are to be properly trained and are to be certified by the Society, as required in the individual applications.

Welders intended to be engaged in the fusion welding of steels for hull structures are to be certified according to the requirements provided in Sec 6.

Welders to be engaged in welding other than those referred to in Sec 6 are to be qualified according to national or international welder qualification standards, such as ISO 9606.

The acceptance of other standards is subject to preliminary examination by the Society.

The certification is to be in due course of validity.

The recognition of certificates issued by other certification bodies will be evaluated on a case by case basis and verification of welders qualification will be required as deemed necessary.

2.2.4 Welding operators (1/1/2018)

Welding operators intended to be engaged in the fusion welding of steels for hull structures are to be certified according to the requirements provided in Sec 6.

For welding other than those referred to in Sec 6 it is sufficient that personnel manning fully automatic welding machines are to be competent and sufficiently trained.

Record of training is to be maintained and submitted to the Society on demand.

2.2.5 Welding supervision (1/7/2003)

Welders are to be supervised and assisted, in the course of the welding operation, by an adequate number of competent supervisors, such as to ensure efficient control of the welding production.

In the Rules for the certification of welding inspectors, the duties of the personnel who perform specific inspection activities on the production by welding are listed in detail, according to levels of competence.

Certification of the welding inspectors is not compulsory and is left to the discretion of the Manufacturer, except in particular cases where it may be required by the Society.

2.2.6 NDT operators (1/7/2006)

Non-destructive tests are to be carried out by personnel, qualified according to the requirements of Ch 1, Sec 1, [3.6.4].

The qualifications are to be appropriate to the particular application.

2.3 Welding procedures

2.3.1 Approval of consumables

Consumables are to be approved in accordance with the provisions of Sec 2.

Requirements for approval of welding processes, where non-approved welding consumables are allowed to be used, are given in Sec 4.

2.3.2 Choice of consumables

Requirements regarding the use of the various grades of approved consumables are indicated in the parts of the Rules concerning the application or at the time of plan approval.

In particular, for consumables intended for welding hull and structural C and C-Mn steels, the requirements given in Pt B, Ch 12, Sec 1 apply.

In the case of consumables approved for Mo and Cr-Mo weldable steels, the choice of the grade of the consumables is to be made such that the nominal chemical composition of the deposited metal corresponds to that of the base material; where electrodes are used, they are to be of the basic covered low hydrogen type.

In the case of consumables approved for C, C-Mn and Ni ferritic steels intended for low temperature service, the choice of the grade of consumable is to be made such that the strength of the weld metal is appropriate to the base metal to be welded and the temperature at which the consumables satisfy the required impact strength properties is as required in the individual applications; where electrodes are used, they are to be of the basic covered low hydrogen type.

In the case of consumables approved for welding stainless steels, the selection of consumables and base metals which can be welded is indicated in Sec 4, [3].

In the case of consumables approved for welding aluminium alloys, the selection is to be made on the basis of corrosion resistance and strength as indicated in Sec 4, [6].

2.3.3 Approval of welding procedures (1/7/2008)

Welding procedures are to be approved in accordance with the provisions of Sec 4.

For specific applications relevant to ships intended to carry liquefied gases, the relevant requirements of Pt E, Ch 9, Sec 6 apply.

2.4 Type of joints, edge preparations and size

2.4.1 General

The types of joints and the edge preparations are to be appropriate to the welding processes adopted, to the particular structures and to the stresses to which they are subjected, to the satisfaction of the Society.

Size and design are to be in accordance with requirements given in the Rules relevant to the applications, approved plans, and specific provisions stipulated for hulls in Part B and for pressure systems and machinery in Part C.

2.5 Welding execution and control

2.5.1 Edge preparation, surface conditions, assembly pre- and post-weld heating, welding sequences and inspections of the welded structures are to be in accordance with good practice and, where applicable, are to comply with the requirements given in the Rules relevant to the applications (Part B for hulls and Part C for pressure systems and machinery).

SECTION 2

APPROVAL OF WELDING CONSUMABLES

1 General

1.1 Application

1.1.1 (1/7/2019)

The requirements of this Section apply to the approval and inspection of consumables for welding normal and higher strength hull structural steels, high strength steels, chromium and chromium-molybdenum steels, nickel steels for low temperature applications, austenitic and austenitic-ferritic stainless steels, and aluminium alloys.

1.1.2 (1/7/2019)

Articles [1] to [7] of this Section provide the requirements for the approval and inspection of welding consumables used for the following hull structural steels:

- normal strength steels Grades A, B, D and E;
- higher strength steels Grades A32, D32, E32, A36, D36 and E36;
- higher strength steels with minimum yield strength 390 N/mm²: Grades A40, D40 and E40;
- higher strength steels for low temperature application: Grades F32, F36 and F40.

Welding consumables for high strength steels for welded structures are to comply with the requirements of Article [8].

The requirements of articles [1] to [7] may also be applied to the corresponding grades of steel forgings and castings, and of comparable steels intended for other structural applications or pressure systems.

1.1.3 Categories of products (1/7/2019)

The concerned welding consumables are divided into several categories as follows:

- covered electrodes for manual and gravity welding;
- wire/flux combinations for two run or multi-run submerged arc welding;
- solid wire/gas combinations for continuous wire arc welding;
- flux cored wires for continuous wire arc welding with or without shielding gas;
- consumables for use in electroslag and electrogas vertical welding.

1.2 Grading

1.2.1 Basic groups and grades (1/7/2019)

Filler metals are divided into three groups:

- normal strength filler metals for welding normal strength hull structural steels;

- higher strength filler metals for welding normal and higher strength hull structural steels with minimum yield strength up to 355 N/mm²;
- higher strength filler metals for welding normal and higher strength hull structural steels with minimum yield strength up to 390 N/mm².

Each of the three groups is based on corresponding tensile strength requirements.

Each filler metal group is further divided into several grades:

- Grades 1, 2 and 3 for ordinary-strength filler metals;
- Grades 1Y, 2Y, 3Y and 4Y for higher strength filler metals for steels up to 355 N/mm² yield strength;
- Grades 2Y40, 3Y40, 4Y40 and 5Y40 for higher strength filler metals for steels up to 390 N/mm² yield strength.

The Grade assignment is given in respect of Charpy V-notch impact test requirements.

For each strength basic group, welding consumables, which have satisfied the requirements for a higher toughness grade are considered as complying with the requirements for a lower toughness grade.

1.2.2 Correlation of welding consumables to hull structural steel grades (1/7/2019)

The correlation between the hull steel grades and the welding consumables grades that are to be used for the hull steel welding, is stated in Tab 1.

When joining normal to higher strength structural steel, consumables of the lowest acceptable grade for either material being joined may be used.

When joining steels of the same strength level but of different toughness grade, consumables of the lowest acceptable grade for either material being joined may be used.

It is recommended that controlled low hydrogen type consumables are used when joining higher strength structural steel to the same or lower strength level, except that other consumables are used, at the discretion of the Society, when the carbon equivalent is below or equal to 0.41%. When other than controlled low hydrogen type electrodes are used appropriate procedure tests for hydrogen cracking may be conducted at the discretion of the Society.

1.2.3 Hydrogen marks (1/7/2019)

Welding consumables of Grades 2 and 3 and Grades 2Y, 3Y and 4Y and of Grades 2Y40, 3Y40, 4Y40 and 5Y40, for which the hydrogen content has been controlled in accordance with [4.5.3] are identified by the mark H15, H10 or H5.

Table 1 : Correlation of welding consumables to hull structural steels (1/7/2019)

Grades of welding consumables (see notes)	Hull structural steel grades											
	A	B	D	E	A32/36	D32/36	E32/36	F32/36	A40	D40	E40	F40
1, 1S, 1T, 1M, 1TM, 1V	X											
1YS, 1YT, 1YM, 1YTM, 1YV	X				(2)							
2, 2S, 2T, 2M, 2TM, 2V	X	X	X									
2Y, 2YS, 2YT, 2YM, 2YTM, 2YV	X	X	X		X	X						
2Y40, 2Y40S, 2Y40T, 2Y40M, 2Y40TM, 2Y40V	(1)	(1)	(1)		X	X			X	X		
3, 3S, 3T, 3M, 3TM, 3V	X	X	X	X								
3Y, 3YS, 3YT, 3YM, 3YTM, 3YV	X	X	X	X	X	X	X					
3Y40, 3Y40S, 3Y40T, 3Y40M, 3Y40TM, 3Y40V	(1)	(1)	(1)	(1)	X	X	X		X	X	X	
4Y, 4YS, 4YT, 4YM, 4YTM, 4YV	X	X	X	X	X	X	X	X				
4Y40, 4Y40S, 4Y40T, 4Y40M, 4Y40TM, 4Y40V	(1)	(1)	(1)	(1)	X	X	X	X	X	X	X	X
5Y40, 5Y40S, 5Y40T, 5Y40M, 5Y40TM, 5Y40V	(1)	(1)	(1)	(1)	X	X	X	X	X	X	X	X

(1) The welding consumables approved for steel Grades A40, D40, E40 and/or F40 may also be used for welding of the corresponding grades of normal strength steels subject to the special agreement with the Society.

(2) When joining higher strength steels using Grade 1Y welding consumables, the material thicknesses should not exceed 25 mm.

Suffixes definition:

'S': semi-automatic (for semi-mechanized welding);

'T': two run technique (for welding in one pass on each side);

'M': multi-run technique;

'TM': both two run and multi-run technique;

'V': vertical welding process (for electrogas or electroslag welding).

1.3 Manufacture

1.3.1 (1/7/2019)

The manufacturer's plant, methods of production and quality control of welding consumables are to be such as to ensure reasonable uniformity in manufacture.

2 Approval procedure

2.1 Plant inspection

2.1.1 (1/7/2019)

The Surveyor is to be satisfied that the manufacturer's plant, methods of production and quality control of welding consumables are to be such as to ensure a reasonable uniformity in manufacture, as mentioned in [1.3].

2.2 Test assemblies

2.2.1 Preparation (1/7/2019)

The test assemblies are to be prepared under the supervision of the Surveyor, and all tests are to be carried out in his presence.

When a welded joint is performed, the edges of the plates are to be bevelled either by mechanical machining or by oxygen cutting; in the later case, a de-scaling of the bevelled edges is necessary.

2.2.2 Welding conditions (1/7/2019)

The welding conditions used such as amperage, voltage, travel speed, etc. are to be within the range recommended by the manufacturer for normal good welding practice. Where a filler material is stated to be suitable for both alternating current (AC) and direct current (DC), AC is to be used for the preparation of the test assemblies.

2.3 Firms with several factories - sister firms

2.3.1 (1/7/2019)

When a filler product is manufactured in several factories of the same company, the complete series of approval tests should be carried out in one of the works only. In the other factories, a reduced test programme at least equivalent to annual tests is permitted if the manufacturer can certify that the materials used and the fabrication process are identical with those used in the main works.

This requirement is applicable to all manufacturers of filler products under license (sister firms). However, should there be any doubt, complete test-series may be required.

The same applies to the approval and control tests of consumables already approved for one Manufacturer, when the consumables are transferred to another company for sale under a different brand name under the conditions specified by the Society.

In the case of wire flux combination for submerged arc welding, if a unique powder flux is combined with different wires coming from several factories belonging to the same firm, it may be admitted to perform only one test-series if the different wires are conformable to the same technical specification, after approval of the Society.

2.4 Annual inspection and tests

2.4.1 (1/7/2019)

The production techniques and associated quality control procedures at all establishments approved for the manufacture of welding consumables are to be subjected to an annual re-appraisal. On these occasions, samples of the approved consumable are to be selected by the Surveyor and subjected to the tests detailed in subsequent Articles of this Section. These are to be completed and reported within the one year period beginning at the initial approval date, and repeated annually so as to provide at least an average of one annual test per year.

Equivalent alternative arrangements may be accepted subject to special agreement with the Society.

2.5 Alterations to approved consumables

2.5.1 (1/7/2019)

Any alteration proposed by the manufacturer to the approved consumable which may result in a change in the chemical composition and the mechanical properties of the deposited metal, is to be immediately notified to the Society. Additional tests may be deemed necessary by the Society.

2.6 Upgrading and uprating

2.6.1 (1/7/2019)

Upgrading and uprating of welding consumables will be considered only at manufacturer's request, preferably at the time of annual testing.

Generally, for this purpose, tests from butt weld assemblies will be required in addition to the normal annual approval tests.

For upgrading referring to impact properties, Charpy V-notch impact tests are to be performed at the upgrade temperature on the respective butt weld assemblies required for approval.

For upgrading referring to higher strength steels, all butt weld tests required for the approval are to be effected using higher strength steel as parent metal.

For upgrading referring to hydrogen content, tests according to [4.5] are to be carried out as appropriate.

Downgrading or withdrawal of the approval occurs when the prescribed tests and re-tests fail to meet the requirements.

2.7 Additional tests

2.7.1 (1/7/2019)

The classification societies may request, in a particular case, additional tests or requirements as may be considered necessary.

2.8 Manufacturer's responsibilities

2.8.1 (1/7/2019)

After the approval has been obtained, irrespective of the periodical tests carried out by the Society, the Manufacturer is fully responsible for the quality of the finished product and compliance with the specified requirements, as verified in the approval and periodical control tests.

The Manufacturer is to keep up-to-date records of the manufacture of the approved consumables, including details of the history of the single productions and results of associated tests. The Society is to have free access to these records at all times.

The Manufacturer is responsible for reporting to the Society any major modifications introduced in the production procedure subsequent to its approval.

Full compliance on the part of the Manufacturer with all the requirements stated by the Society in connection with the approval of consumables is an essential condition for granting and renewing such approval.

3 Mechanical testing procedure

3.1 Test specimens

3.1.1 (1/7/2019)

Deposited metal and butt weld tensile, butt weld bend and Charpy V-notch impact test specimens are to be machined to the dimensions given in Ch 1, Sec 2.

3.1.2 (1/7/2019)

The requirements for the specimens location and preparation for each test are defined in this Article.

a) Deposited metal tensile test

The longitudinal axis must coincide with the centre of the weld and:

- 1) the mid thickness of the weld in the deposited metal test assemblies;
- 2) the mid thickness of the 2nd run in the two-run welded test assemblies.

The specimens may be heated to a temperature not exceeding 250°C for a period not exceeding 16 hours for hydrogen removal prior to testing.

b) Butt weld tensile test

The upper and lower surfaces of the weld are to be filed, ground or machined flush with the surface of the plate.

c) Butt weld bend test

The upper and lower surfaces of the weld are to be filed, ground or machined flush with the Surface of the plate

and the sharp corners of the specimens rounded to a radius not exceeding 2 mm.

d) Charpy V-notch impact test

The test specimens are to be cut with their longitudinal axes transverse to the weld length and:

- 1) at mid thickness of the weld in the deposit metal and butt weld test assemblies with multi-run technique;
- 2) on the 2nd run side, 2 mm maximum below the surface in the two-run welded test assemblies;
- 3) 2 mm maximum below one surface in the electroslag or electrogas welded test assemblies.

The notch is to be cut in the face of the test piece perpendicular to the surface of the plate and is to be positioned in the centre of the weld and, for electroslag and electrogas welded test assemblies, also at 2 mm from the fusion line in the deposited metal.

3.2 Testing procedures

3.2.1 General (1/7/2019)

The test specimens for mechanical tests are to be taken from the welded assemblies as indicated in the various Articles.

The requirements relevant to the calibration of the equipment, preparation of test specimens and testing procedure, detailed in Ch 1, Sec 2, are also to be complied with, as appropriate.

3.2.2 Tensile tests (1/7/2019)

On deposited metal test specimens, the values of yield stress, tensile strength and elongation are to be recorded.

On butt weld specimens, the values of tensile strength are to be recorded together with the position of fracture.

3.2.3 Bend (1/7/2019)

The test specimens are to be capable of withstanding, without fracture or crack, being bent through an angle of 120° over a former having a diameter three times the thickness of the specimen. However, superficial cracks of less than 3 mm long on the outer surface should not be taken into consideration.

For each set of bend tests one specimen is to be tested with the face of the weld in tension and the other with the root of the weld in tension except in the electroslag or electrogas welded test assemblies, where side bend tests are carried out in lieu of face and root bend tests.

3.2.4 Charpy V-notch impact (1/7/2019)

A set of three test specimens is to be prepared and tested. The average absorbed energy value is to comply with the requirements of subsequent sections. One individual value may be less than the required average value provided that it is not less than 70% of this value.

The test temperature for Grades 2, 2Y, 2Y40, 3, 3Y, 3Y40, 4Y, 4Y40 and 5Y40 test pieces is to be controlled to within $\pm 2^\circ\text{C}$ of the prescribed temperature.

3.3 Re-test procedures

3.3.1 Tensile and bend (1/7/2019)

Where the result of a tensile or bend test does not comply with the requirements, duplicate test specimens of the same type are to be prepared and satisfactorily tested. Where insufficient original welded assembly is available, a new assembly is to be prepared using welding consumables from the same batch. If the new assembly is made with the same procedure (particularly the number of runs) as the original assembly, only the duplicate re-test specimens needs to be prepared and tested. Otherwise, all test specimens should be prepared as for re-testing.

3.3.2 Charpy V-notch impact (1/7/2019)

Re-test requirements for Charpy impact tests are to be in accordance with Ch 1, Sec 2. Further re-tests may be made at the Surveyor's discretion, but these are to be made on a new welded assembly and are to include all tests required for the original assembly, even those which were previously satisfactory.

4 Covered electrodes for manual arc welding

4.1 General

4.1.1 Grades (1/7/2019)

Depending on the results of the Charpy V-notch impact tests, electrodes are divided into the following grades:

- for normal strength steel: Grades 1, 2 and 3
- for higher strength steel with minimum yield strength up to 355 N/mm²: Grades 2Y and 3Y and 4Y (Grade 1Y not applicable for manual welding)
- for higher strength steels with minimum yield strength up to 390 N/mm²: Grades 2Y40, 3Y40, 4Y40 and 5Y40.

4.1.2 Hydrogen marks (1/7/2019)

If the electrodes are in compliance with the requirements of the hydrogen test given in [4.5], a suffix H15, H10 or H5 will be added to the Grade mark.

4.2 Deposited metal tests

4.2.1 Preparation of deposited metal test assemblies (1/7/2019)

Two deposited metal test assemblies are to be prepared in the downhand position as shown in Fig 1, one with 4 mm diameter electrodes and the other with the largest size manufactured. If an electrode is available in one diameter only, one test assembly is sufficient. Any grade of ship structural steel may be used for the preparation of these test assemblies.

The weld metal is to be deposited in single or multi-run layers according to normal practice, and the direction of deposition of each layer is to alternate from each end of the plate, each run of weld metal being not less than 2 mm and not more than 4 mm thick. Between each run, the assembly is to be left in still air until it has cooled to less than 250°C but not below 100°C, the temperature being taken in the centre of the weld, on the surface of the seam. After welding, the test assemblies are not to be subjected to any heat treatment.

Figure 1 : Deposited metal test assembly (1/7/2019)

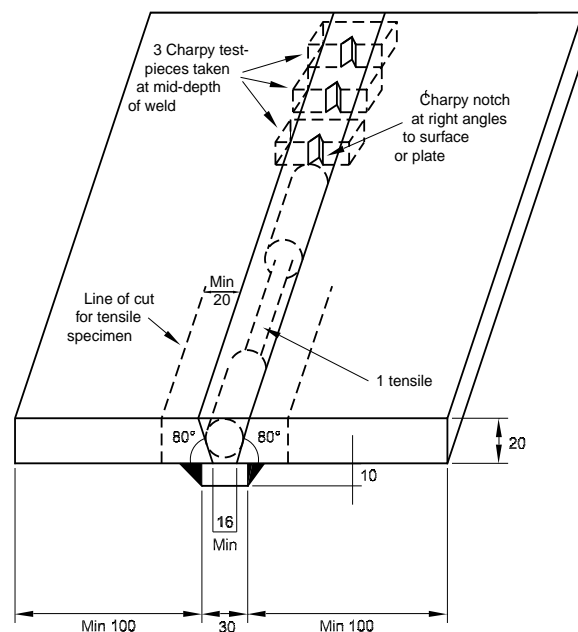

All the dimensions are in mm, unless otherwise indicated.

Table 2 : Requirements for deposited metal tests (covered manual electrodes) (1/7/2019)

Grade	Yield stress (N/mm ²) minimum	Tensile strength (N/mm ²)	Elongation on 50 mm gauge length (L ₀ =5 d) % minimum	Charpy V-notch impact test	
				Test temperature (C°)	Average Energy J minimum
1	305	400 - 560	22	+ 20	47
2				0	47
3				- 20	47
2Y	375	490 - 660	22	0	47
3Y				- 20	47
4Y				- 40	47
2Y40	400	510 - 690	22	0	47
3Y40				- 20	47
4Y40				- 40	47
5Y40				- 60	47

4.3 Butt weld tests

4.3.1 Preparation of butt weld test assemblies (1/7/2019)

Butt weld assemblies as shown in Fig 2 are to be prepared for each welding position (downhand, horizontal-vertical, vertical-upward, vertical-downward and overhead) for which the electrode is recommended by the manufacturer, except that electrodes satisfying the requirements for downhand and vertical-upward positions will be considered as also complying with the requirements for the

horizontal-vertical position subject to the agreement of the Society.

Where the electrode is to be approved only in the downhand position, an additional test assembly is to be prepared in that position.

For the preparation of the test assemblies one of the steel grades listed in Tab 3 for the individual electrode grades is to be used.

Where higher strength steel with minimum yield strength 315 N/mm² is used for grade 2Y, 3Y and 4Y electrodes, the

actual tensile strength of the steel is to be not less than 490 N/mm². The chemical composition including the content of grain refining elements is to be reported.

4.3.2 Sequence of welding (1/7/2019)

The following welding procedure is to be adopted in making test assemblies:

Downhand (a). The first run with 4 mm diameter electrode. Remaining runs (except the last two layers) with 5 mm diameter electrodes or above according to the normal welding practice with the electrodes. The runs of the last two layers with the largest diameter of electrode manufactured.

Downhand (b). (Where a second downhand test is required). First run with 4 mm diameter electrode. Next run with an electrode of intermediate diameter of 5 mm or 6 mm, and the remaining runs with the largest diameter of electrode manufactured.

Horizontal-vertical. First run with 4 mm or 5 mm diameter electrode. Subsequent runs with 5 mm diameter electrodes.

Vertical-upward and overhead. First run with 3.25 mm diameter electrode. Remaining runs with 4 mm diameter electrodes or possibly with 5 mm if this is recommended by the manufacturer for the positions concerned.

Vertical-downward. If the electrode tested is intended for vertical welding in the downward direction, this technique is to be adopted for the preparation of the test assembly using electrode diameters as recommended by the manufacturer.

For all assemblies the back sealing runs are to be made with 4 mm diameter electrodes in the welding position appropriate to each test sample, after cutting out the root run to clean metal. For electrodes suitable for downhand welding only, the test assemblies may be turned over to carry out the back sealing run.

Normal welding practice is to be used, and between each run the assembly is to be left in still air until it has cooled to less than 250°C but not below 100°C, the temperature being taken in the centre of the weld, on the surface of the seam. After welding, the test assemblies are not to be subjected to any heat treatment.

4.3.3 Radiographic examination (1/7/2019)

It is recommended that the welded assemblies be subjected to a radiographic examination to ascertain if there are any defects in the weld prior to the preparation of test specimens.

4.3.4 Execution of tests (1/7/2019)

The test specimens as shown in Fig 2 are to be prepared from each test assembly. Tests are to be performed according to [3].

Figure 2 : Butt weld test assembly (1/7/2019)

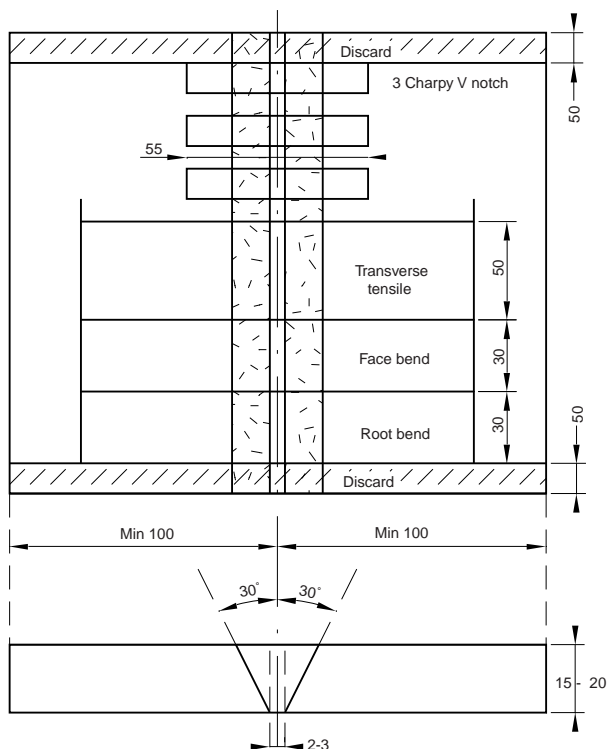

All the dimensions are in mm, unless otherwise indicated.

Table 3 : Steel grades for the preparation of the test assembly (1/7/2019)

Grade of electrodes	Grade of the steel for the preparation of the test assembly
1	A
2	A, B, D
3	A, B, D, E
2Y	A32, A36, D32, D36
3Y	A32, A36, D32, D36, E32, E36,
4Y	A32, A36, D32, D36, E32, E36, F32, F36
2Y40	A40, D40
3Y40	A40, D40, E40
4Y40	A40, D40, E40, F40
5Y40	A40, D40, E40, F40

4.3.5 Result of tests and requirements (1/7/2019)

The results of all tensile and impact tests are to comply with the requirements of Tab 4 as appropriate. The position of fracture in the transverse tensile test is to be reported. The bend test specimens can be considered as complying with the requirements if, after bending, no crack or defect having any dimensions exceeding 3 mm can be seen on the outer surface of the test specimen.

Table 4 : Requirements for butt weld test (covered manual electrodes) (1/7/2019)

Grade	Tensile strength (transverse test) (N/mm ²)	Charpy V-notch impact test		
		Test temperature (C°)	Average Energy J minimum	
			Downhand, horizontal-vertical, overhead	Vertical (upward and down- ward)
1	400	+ 20	47	34
2		0	47	34
3		- 20	47	34
2Y	490	0	47	34
3Y		- 20	47	34
4Y		- 40	47	34
2Y40	510	0	47	39
3Y40		- 20	47	39
4Y40		- 40	47	39
5Y40		- 60	47	39

4.4 Hot cracking test

4.4.1 (1/7/2019)

Hot cracking test may be required at the discretion of the Society.

4.5 Hydrogen test

4.5.1 Hydrogen marks (1/7/2019)

At the request of the manufacturer, electrodes may be submitted to a hydrogen test. A suffix H15, H10 or H5 will be added to the grade number to indicate compliance with the requirements of this test.

4.5.2 Execution of hydrogen test (1/1/2023)

The mercury method or thermal conductivity detector method according to standard ISO 3690:2018 is to be used. Four weld assemblies are to be prepared. The temperature of the specimens and minimum holding time are to comply with Tab 5, according to the measuring method respectively.

The use of the glycerine method may be admitted at the Society discretion. This method is described hereafter.

Four test specimens are to be prepared, measuring 12 mm by 25 mm in cross section by about 125 mm in length. The parent metal may be any grade of ship structural steel and, before welding, the specimens are to be weighed to the nearest 0.1 g. On the 25 mm surface of each test specimen, a single bead of welding is to be deposited, about 100 mm in length by a 4 mm electrode, fusing 150 mm of the electrode. The welding is to be carried out with an arc as short as possible and with a current of about 150 A.

The electrodes, prior to welding, can be submitted to the normal drying process recommended by the manufacturer. Within 30 seconds of the completion of the welding of each

specimen the slag is to be removed and the specimen quenched in water at approximately 20°C.

After 30 seconds in the water, the specimen is to be cleaned and dried, and then placed in an apparatus suitable for the collection of hydrogen by displacement of glycerine. The glycerine is to be kept at a temperature of 45°C during the test. All four specimens are to be welded and placed in individual hydrogen collecting apparatus within a period of time which will limit any variation in hydrogen content due to variation in exposure to moisture absorption following any drying treatment. This should not exceed 30 minutes.

The specimens are to be kept immersed in the glycerine for a period of 48 hours and, after removal, are to be cleaned in water and spirit dried and weighed to the nearest 0.1 g to determine the amount of weld deposit. The amount of gas involved is to be measured to the nearest 0.05 cm³ and corrected for temperature and pressure to 0°C and 760 mm Hg.

Table 5 : Hydrogen test thermal conductivity detector measuring method (1/7/2019)

Measuring Method		Test Temperature (°C)	Minimum Holding Time (h)
Thermal Conductivity Detector Method (1)	Gas Chromatography	45	72
		150	6
(1) The use of hot carrier gas extraction method may be considered subject to verification of the testing procedure to confirm that collection and measurement of the hydrogen occurs continuously until all of the diffusible hydrogen is quantified.			

4.5.3 Results to be obtained (1/7/2019)

The individual and average diffusible hydrogen contents of the four specimens are to be reported, and the average value in cm³ per 100 grams is not to exceed the values in Tab 6.

Table 6 : Hydrogen content (1/7/2019)

Mark	Diffusible Hydrogen Contents	Measuring Method
H15	15 (1)	Mercury Method
H10	10 (2)	Thermal Conductivity Detector Method Glycerine Method
H5	5	Mercury Method Thermal Conductivity Detector Method

(1) 10 cm³ per 100 grams where the glycerine method is used.
 (2) 5 cm³ per 100 grams where the glycerine method is used.
Note 1: The glycerine method is not to be used for the welding consumables with H 5 mark.

4.6 Covered electrodes for manual fillet welding

4.6.1 General (1/7/2019)

Where an electrode is submitted only to approval for fillet welding and to which the butt weld test provided in [4.3] is not considered applicable, the first approval tests are to consist of the fillet weld tests given in [4.6.2], and deposited metal tests similar to those indicated in [4.2]. Where an electrode is submitted to approval for both butt and fillet welding, the first approval tests may, at the discretion of the Society, include one fillet weld test as detailed hereunder and welded in the horizontal-vertical position.

4.6.2 Fillet weld test assemblies (1/7/2019)

When the electrode is proposed only for fillet welding, fillet weld assemblies as shown in Fig 3 are to be prepared for each welding position (horizontal-vertical, vertical upwards, vertical downwards or overhead) for which the electrode is recommended by the manufacturer. The length of the test assemblies L is to be sufficient to allow at least the deposition of the entire length of the electrode being tested.

The grade of steel used for the test assemblies is to be as detailed in [4.3.1].

The first side is to be welded using the maximum size of electrode manufactured and the second side is to be welded using the minimum size of electrode manufactured and recommended for fillet welding.

The fillet size will in general be determined by the electrode size and the welding current employed during testing.

4.6.3 Tests on fillet weld assemblies (1/7/2019)

a) Macrographs

Each test assembly is to be sectioned to form three macro-sections each about 25mm thick. They are to be examined for root penetration, satisfactory profile, freedom from cracking and reasonable freedom from porosities and slag inclusions.

b) Hardness

At the discretion of the Society, the hardness of the weld, of the heat affected zone (HAZ) and of parent metal may be determined, and reported for information (see Fig 4).

c) Fracture

One of the remaining sections of the fillet weld is to have the weld on the first side gouged or machined to facilitate breaking the fillet weld, on the second side by closing the two plates together, submitting the root of the weld to tension. On the other remaining section, the weld on the second side is to be gouged or machined and the section fractured using the same procedure. The fractured surfaces are to be examined and there should be no evidence of incomplete penetration, or internal cracking and they should be reasonably free from porosity.

Figure 3 : Fillet weld test assembly (1/7/2019)

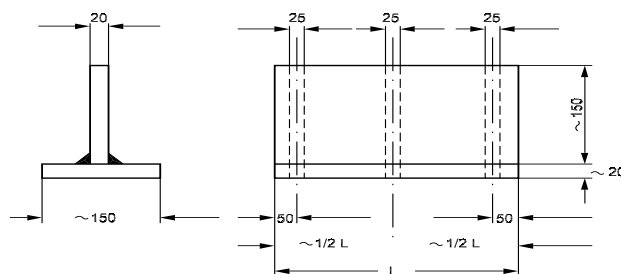
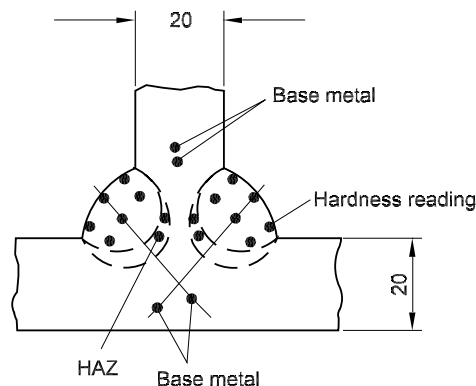

Figure 4 : Hardness readings (1/7/2019)



4.7 Covered electrodes for gravity or contact welding

4.7.1 (1/7/2019)

Where an electrode is submitted solely to approval for use in contact welding using automatic gravity or similar welding devices, deposited metal tests, fillet weld tests (see [4.6]) and, where appropriate, but weld tests similar to those for normal manual electrodes are to be carried out using the process for which the electrode is recommended by the manufacturer.

Where a covered electrode is submitted to approval for use in contact welding using automatic gravity or similar welding devices in addition to normal manual welding, fillet weld and, where appropriate, butt weld tests, using the gravity of other contact device as recommended by the manufacturer, are to be carried out in addition to the normal approval tests.

In the case of a fillet welding electrode using automatic gravity or similar contact welding devices, the fillet welding should be carried out using the welding process recommended by the manufacturer, with the longest size of the electrode manufactured. The manufacturer's recommended current range is to be reported for each electrode size.

Where approval is requested for the welding of both normal strength and higher strength steel, the assemblies are to be prepared using higher strength steel.

4.8 Annual tests and upgrading

4.8.1 (1/7/2019)

This paragraph defines the scope of annual tests and periodical inspections of manufacturer's plant.

All establishments where approved electrodes are manufactured are to be subject to annual inspection.

The annual tests are to consist of at least the following:

a) Covered electrode for normal manual arc welding

Two deposited metal test assemblies are to be prepared in accordance with [4.2]. The mechanical properties (one tensile test, 3 Charpy-V impact tests on each assembly) are to be in accordance with Tab 2. This also applies to electrodes which are approved only for fillet welding.

At the discretion of the Society a butt weld test to be welded in down-hand or in vertical position, can be required in lieu of the deposited metal test 4 mm electrodes. Three Charpy V-notch impact test specimens are to be taken from the butt weld assembly.

For Mark H 10 and Mark H 5 covered electrodes, a hydrogen test following [4.5] can also be required for each annual test at the discretion of the Society.

b) Covered electrodes for gravity or contact welding

Where an electrode is approved solely for gravity or contact welding, the annual test is to consist of one deposited metal test assembly using the gravity or other contact device as recommended by the manufacturer. If

this electrode is approved also for normal manual arc welding the annual test is to be performed according to [4.8.1] a).

4.8.2 Upgrading and upgrading of electrodes (1/7/2019)

- a) Upgrading and upgrading will be considered only at the manufacturer's request, preferably at the time of annual testing. Generally, for this purpose, tests on butt-weld assemblies will be required in addition to the normal re-approval tests.
- b) Upgrading refers to notch toughness and consequently, only Charpy V impact tests are required from the respective butt-weld assemblies as required by [4.3] (downhand, horizontal vertical, vertical up or/and down, overhead, as applicable), and have to be performed at the upgraded temperature. These butt-weld tests are to be made in addition to the normal requirements for annual deposited metal tests (which have, of course, to take into consideration the upgraded temperature for Charpy V specimens).
- c) Upgrading refers to the extension of approval in order to cover the welding of higher strength steels; of course, welding of normal strength steels continue to be covered by the extended approval, as stated in [1.2.1].

For this purpose all butt-weld tests are to be made again, as required in [4.3] and using higher strength steel, as parent metal.

5 Wire flux combinations for submerged arc welding

5.1 General

5.1.1 Categories (1/7/2019)

Wire flux combinations for single electrode submerged arc automatic welding are divided into the following two categories:

- For use with the multi-run technique
- For use with the two run technique

Where particular wire-flux combinations are intended for welding with both techniques, tests are to be carried out for each technique.

5.1.2 Grades (1/7/2019)

Depending on the results of impact tests, wire-flux combinations are divided into the following grades:

- For normal strength steel: Grades 1, 2 or 3
- For higher strength steels with minimum yield strength up to 355 N/mm²: Grades 1Y, 2Y, 3Y or 4Y.
- For higher strength steels with minimum yield strength up to 390 N/mm²: Grades 2Y40, 3Y40, 4Y40 or 5Y40.

The suffixes T, M or TM will be added after the grade mark to indicate approval for the two-run technique, multi-run technique or both techniques, respectively.

5.1.3 Multiple electrode submerged arc welding (1/7/2019)

Wire-flux combinations for multiple electrode submerged arc welding will be subject to separate approval tests. They

are to be carried out generally in accordance with the requirements of this section.

5.1.4 Mechanical tests on assemblies (1/7/2019)

Mechanical tests on assemblies with submerged arc welding for wire/flux approval are given in Tab 7.

Table 7 : General table giving the mechanical tests on assemblies with submerged arc welding for wire/flux approval (1/7/2019)

M (multi-run technique)		T (two-run technique)		TM (two-run and multi-run technique)			
Deposited metal assembly	Butt weld assembly	Butt weld assembly (minimum thickness)	Butt weld assembly (maximum thickness)	Deposited metal assembly	Butt Weld Assembly		
					Multi-run technique	Two-run technique	
						(Minimum thickness)	(Maximum thickness)
	2 TT	2 TT	2 TT		2 TT	2 TT	2 TT
	4 TB	2 TB	2 TB		4 TB	4 TB	4 TB
3 CV	3 CV	3 CV	3 CV	3 CV	3 CV	3 CV	3 CV
2 LT			1 LT	1 LT			1 LT

Symbol Definition:
 TT: Transverse Tensile Test on the butt weld assembly
 TB: Transverse Bend Test on the butt weld assembly
 CV: Charpy-V Impact Test in the axis of the weld
 LT: Longitudinal Tensile Test in the weld

5.2 Approval tests for multi-run technique

5.2.1 Grades of steel (1/7/2019)

Where approval for use with the multi-run technique is requested, deposited metal and butt weld tests are to be carried out.

For deposited metal test assembly any grade of ship structural steel may be used.

For butt weld test assembly one of the grades of steel as listed in Tab 8 or the individual grades of wire-flux combinations shall be used.

Grade of electrodes	Grade of the steel for the preparation of the test assembly
4Y40	A40, D40, E40, F40
5Y40	A40, D40, E40, F40

5.2.2 Deposited metal test assembly (1/7/2019)

One deposited metal test assembly is to be prepared as shown in Fig 5.

Welding is to be carried out in the downhand position, and the direction of deposition of each run is to alternate from each end of the plate. After completion of each run, the flux and welding slag is to be removed. Between each run the assembly is to be left in still air until it has cooled to less than 250 °C, but not below 100 °C, the temperature being taken in the centre of the weld, on the surface of the seam. The thickness of the layer is to be not less than the diameter of the wire nor less than 4 mm.

The weld conditions, including amperage, voltage and rate of travel speed are to be in accordance with the recommendations of the manufacturer and are to conform with normal good welding practice for multi-run welding.

At the discretion of the Society, the chemical analysis of the deposited weld metal in this test assembly is to be supplied by the manufacturer and is to include the content of all significant alloying elements.

In accordance with Tab 7, the test specimens as shown in Fig 5 are to be prepared from each test assembly. Tests are to be performed according to requirements in Article [3].

Table 8 : Steel grades for the preparation of the test assembly (1/7/2019)

Grade of electrodes	Grade of the steel for the preparation of the test assembly
1	A
2	A, B, D
3	A, B, D, E
1Y	A32, A36
2Y	A32, A36, D32, D36
3Y	A32, A36, D32, D36, E32, E36,
4Y	A32, A36, D32, D36, E32, E36, F32, F36
2Y40	A40, D40
3Y40	A40, D40, E40

The results of all tests are to comply with the requirements of Tab 9 as appropriate.

Table 9 : Requirements for deposited metal tests (wire-flux combinations) (1/7/2019)

Grade	Yield stress (N/mm ²) minimum	Tensile strength (N/mm ²)	Elongation on 50 mm gauge length (L ₀ =5 d) % minimum	Charpy V-notch impact test	
				Test temperature (C°)	Average Energy J minimum
1	305	400 - 560	22	+ 20	34
2				0	34
3				- 20	34
1Y	375	490 - 660	22	+ 20	34
2Y				0	34
3Y				- 20	34
4Y				- 40	34
2Y40	400	510 - 690	22	0	39
3Y40				- 20	39
4Y40				- 40	39
5Y40				- 60	39

Figure 5 : Deposited metal test assembly (1/7/2019)

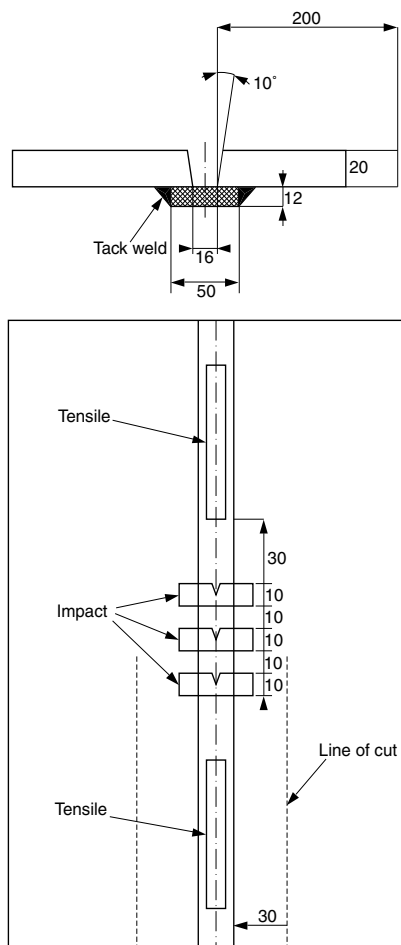

All the dimensions are in mm, unless otherwise indicated.

5.2.3 Butt Weld Test Assembly (1/7/2019)

One butt weld test assembly is to be prepared as shown in Fig 6 in the downhand position by welding together two plates (20 to 25 mm thick), each not less than 150 mm in width and sufficient length to allow the cutting out of test specimens of the prescribed number and size.

The plate edges are to be prepared to form a single vee joint, the included angle between the fusion faces being 60° and the root face being 4 mm.

The welding is to be carried out by the multi-run technique and the welding conditions are to be the same as those adopted for the deposited metal test assembly.

The back sealing run is to be applied in the downhand position after cutting out the root run to clean metal.

After welding the test assembly is not to be subject to any heat treatment.

Figure 6 : Multi-run butt weld test assembly (submerged arc welding) (1/7/2019)

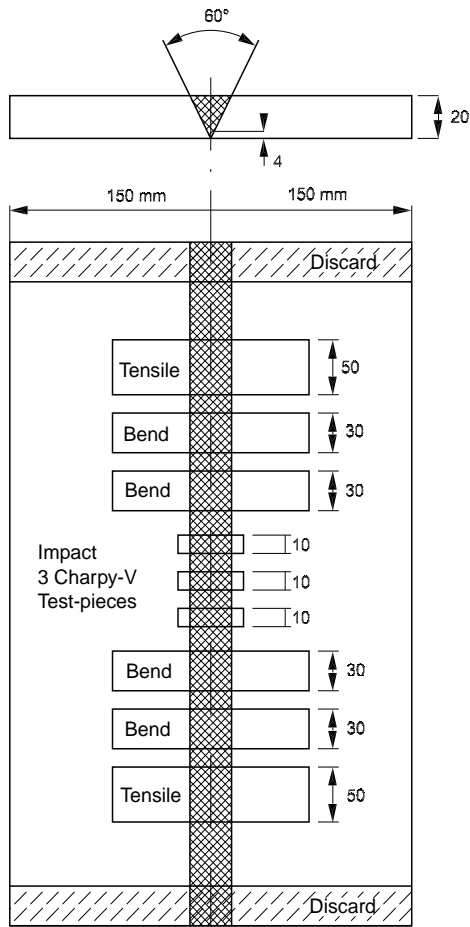

All the dimensions are in mm, unless otherwise indicated.

It is recommended that the welded assembly be subject to a radiographic examination to ascertain if there are any defects in the weld prior to the preparation of test specimens.

The test specimen to be prepared from the welded assembly are given in Tab 7 and shown in Fig 6. The tests are to be performed according to the requirements of [3].

The results of all tensile and impact tests are to comply with the requirements of Tab 10 as appropriate. The position of the fracture in the transverse tensile test is to be reported.

The bend test specimens can be considered as complying with the requirements if, after bending, no crack or defect, having any dimension exceeding 3 mm can be seen on the outer surface of the test specimen.

Table 10 : Requirements for butt weld tests (wire-flux combinations) (1/7/2019)

Grade	Tensile strength (transverse test) (N/mm ²)	Charpy V-notch impact test	
		Test temperature (C°)	Average Energy J minimum
1	400	+ 20	34
2		0	34
3		- 20	34
1Y	490	+ 20	34
2Y		0	34
3Y		- 20	34
4Y		- 40	34
2Y40	510	0	39
3Y40		- 20	39
4Y40		- 40	39
5Y40		- 60	39

5.3 Approval tests for two run techniques

5.3.1 Number of test assemblies (1/7/2019)

Where approval for use with the two-run technique is requested, two butt weld test assemblies are to be prepared using the thicknesses in Tab 11.

Table 11 : Test assembly thicknesses (1/7/2019)

Grade	Test assembly thicknesses
1, 1Y	12 to 15 mm and 20 to 25 mm
2, 2Y, 3, 3Y and 4Y	20 to 25 mm and 30 to 35 mm
2Y40, 3Y40, 4Y40 and 5Y40	20 to 25 mm and 30 to 35 mm

A limitation of the approval to the medium range (up to the maximum welded plate thickness) may be agreed to by the Society. Test assemblies are then to be welded using plates of 12 to 15mm and 20 to 25mm irrespective of the grade for which the approval is requested.

When a wire-flux combination is offered to approval for use with the two-run technique only, it is reminded that no deposited metal test assemblies have to be done. In this case approval tests are limited to the butt welds on two-run assemblies described in [5.3.2].

Where approval is requested for welding of both normal strength and higher strength steel two assemblies are to be prepared using higher strength steel. Two assemblies prepared using normal strength steel may also be required at the discretion of the Society.

5.3.2 Butt weld test assemblies (1/7/2019)

The maximum diameter of wire, grades of steel plate and edge preparation to be used are to be in accordance with Tab 12. Small deviations in the edge preparation may be allowed if requested by the manufacturer. The root gap should not exceed 1 mm.

Each butt weld is to be welded in two runs, one from each side, using amperages, voltages and travel speeds in accordance with the recommendations of manufacturer and normal good welding practice.

After completion of the first run, the flux and welding slag are to be removed and the assembly is to be left in still air until it has cooled to 100°C, the temperature being taken in the centre of the weld, on the surface of the seam.

After welding, the test assemblies are not to be subjected to any heat treatment.

It is recommended that the welded assemblies are subjected to radiographic examination to ascertain if there are any defects in the weld prior to the preparation of test specimens.

The test specimens indicated in Tab 7 and shown in Fig 7 are to be prepared from each test assembly. Tests are to be performed according to [3]. The Charpy V-notch impact test

specimens are to be machined from each welded assembly from the positions and with the orientations shown in Fig 8.

Figure 7 : Butt weld test assembly (1/7/2019)

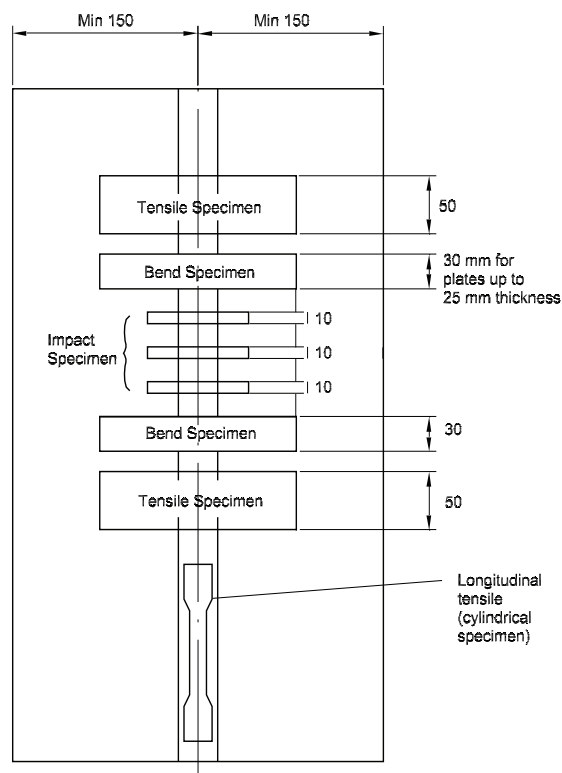

All the dimensions are in mm.

Figure 8 : Charpy V-notch impact test specimens (1/7/2019)

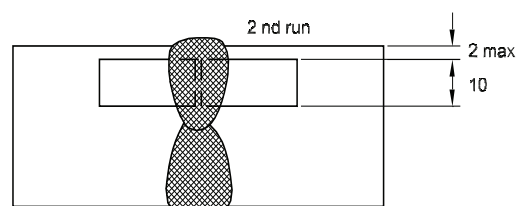

All the dimensions are in mm.

Results of tests and requirements

The results of all tensile and impact tests are to comply with the requirements of Tab 9 and Tab 10 as appropriate. The position of fracture in the transverse tensile test is to be reported. The bend test specimens can be considered as complying with the requirements if, after bending, no crack or defect having any dimensions exceeding 3 mm can be seen on the outer surface of the test specimen.

Chemical analysis

The chemical analysis of the weld metal is to be supplied by the manufacturer, and is to include the content of all significant alloying elements.

Table 12 : Butt weld test assemblies (two-run technique) (1/7/2019)

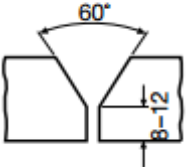
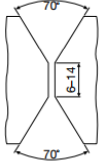
Plate thickness [mm]	Recommended preparation [mm]	Maximum diameter of wire [mm]	Grade wire-flux combination	Grade of normal strength steel	Grade of higher strength steel
about 12-15		5	1 1Y	A -	A32, A36
about 20-25		6	1 1Y 2 2Y 2Y40 3 3Y 3Y40 4Y 4Y40 5Y40	A - A, B or D - - A, B, D or E - - - -	- A32, A36 - A32, A36, D32, D36 A40, D40 - A32, A36, D32, D36, E32, E36 A40, D40, E40 A32, A36, D32, D36, E32, E36, F32, F36 A40, D40, E40, F40 A40, D40, E40, F40
about 30-35		7	2 2Y 2Y40 3 3Y 3Y40 4Y 4Y40 5Y40	A, B or D - - A, B, D or E - - - - -	- A32, A36, D32, D36 A40, D40 - A32, A36, D32, D36, E32, E36 A40, D40, E40 E32, E36, F32, F36 A40, D40, E40, F40 A40, D40, E40, F40

5.4 Annual tests - upgrading

5.4.1 Annual tests (1/7/2019)

All establishments where approved wire/flux combinations are manufactured shall be subject to annual inspection.

Annual tests are to consist of at least the following:

- multi-run technique: on deposited metal assembly and tests: 1 tensile and 3 impact tests.
- two-run technique: one butt weld assembly with 20 mm minimum thickness plate and tests: 1 transverse tensile, 2 transverse bends and 3 impact tests. One longitudinal tensile test specimen is also to be prepared where the wire-flux combination is approved solely for the two-run technique.

The assemblies are to be prepared and tested in accordance with the requirements for initial approval.

Where a wire-flux combination is approved for welding both normal strength and higher strength steel, the latter steel is to be used for the preparation of the butt weld assembly required by [5.4.1] b).

5.4.2 Upgrading and rating (1/7/2019)

Upgrading of wire-flux combinations in connection with the impact properties will be considered as detailed in

[4.8.2] b), and for wire-flux combinations approved for two runs welding, a butt-weld in the maximum thickness approved is to be made and sampled for Charpy-V testing in accordance with [5.3.2].

Upgrading of wire-flux combinations in connection with the tensile properties will be considered as detailed in [4.8.2] c).

6 Wires and wire-gas combinations for metal arc welding

6.1 General

6.1.1 Categories (1/7/2019)

Wire-gas combinations and flux-cored or flux-coated wires (for use with or without a shielding gas) are divided into the following categories for the purposes of approval testing:

- For use in semi-automatic multi-run welding.
- For use in single electrode automatic multi-run welding.
- For use in single electrode automatic two-run welding.

Note 1: The term semi-automatic is used to describe processes in which the weld is made manually by a welder holding a gun through which the electrode wire is continuously fed.

6.1.2 Grades and suffixes (1/7/2019)

- a) Depending on the results of impact tests, wires and wire-gas combinations are divided into the following grades:
- For normal strength steel Grades 1, 2 and 3;
 - For higher strength steels with minimum yield strength up to 355 N/mm²: Grades 1Y, 2Y, 3Y and 4Y.
 - For higher strength steels with minimum yield strength up to 390 N/mm²: Grades 2Y40, 3Y40, 4Y40 and 5Y40.
- b) A suffix "S" will be added after the grade mark to indicate approval for semi-automatic multi-run welding.
- c) For wires intended for automatic welding, the suffixes "T", "M" or "TM" will be added after the grade mark to

indicate approval for two-run, multi-run, or both welding techniques, respectively.

- d) For wires intended for both semi-automatic and automatic welding, the suffixes will be added in combination.

6.1.3 Composition of shielding gas (1/7/2019)

- a) Where applicable, the composition of the shielding gas is to be reported. Unless otherwise agreed by the Society, additional approval tests are required when a shielding gas is used other than that used for the original approval tests.
- b) The approval of a wire in combination with any particular gas can be applied or transferred to any combination of the same wire and any gas in the same numbered group as defined in Tab 13, subject to the agreement of the Society.

Table 13 : Compositional limits of designated groups of gas types and mixtures (1/7/2019)

Group		Gas composition (Vol. %)			
		CO ₂	O ₂	H ₂	A _r
M1	1	> 0 to 5	-	> 0 to 5	Rest (1) (2)
	2	> 0 to 5	-	-	Rest (1) (2)
	3	-	> 0 to 3	-	Rest (1) (2)
	4	> 0 to 5	> 0 to 3	-	Rest (1) (2)
M2	1	> 0 to 25	-	-	Rest (1) (2)
	2	-	> 3 to 10	-	Rest (1) (2)
	3	> 0 to 25	> 0 to 8	-	Rest (1) (2)
M3	1	> 25 to 50	-	-	Rest (1) (2)
	2	-	> 10 to 15	-	Rest (1) (2)
	3	> 5 to 50	> 8 to 1	-	Rest (1) (2)
C	1	100	-	-	-
	2	Rest	> 0 to 30	-	-

(1) Argon may be substituted by Helium up to 95% of the Argon content.
(2) Approval covers gas mixtures with equal or higher Helium contents only.

6.1.4 Low hydrogen approval (1/7/2019)

- a) Flux-cored or flux-coated wires which have satisfied the requirements for Grades 2, 2Y, 2Y40, 3, 3Y, 3Y40, 4Y, 4Y40 and 5Y40 may, at manufacturer's option, be submitted to the hydrogen test as detailed in [4.5], using the manufacturer's recommended welding conditions and adjusting the deposition rate to give a weight of weld deposit per sample similar to that deposited when using manual electrodes.
- b) A suffix H15, H10 or H5 will be added to the grade mark, in the same conditions as for manual arc welding electrodes (see [4.5.3] above) to indicate compliance with the requirements of the test.

6.2 Approval for semi-automatic multi-run welding**6.2.1 General (1/7/2019)**

Approval tests for semi-automatic multi-run welding are to be carried out generally in accordance with [4], except as required in this article, using the semi-automatic multi-run technique for the preparation of all test assemblies.

6.2.2 Preparation of deposited metal assemblies (1/7/2019)

Two deposited metal test assemblies are to be prepared in the downhand position as shown in Fig 1, one using the smallest diameter, and the other using the largest diameter of wire intended for the welding of ship structures. Where

only one diameter is manufactured, only one deposited metal assembly is to be prepared.

The weld metal is to be deposited according to the practice recommended by the manufacturer, and the thickness of each layer of weld metal is to be between 2 and 6 mm.

6.2.3 Chemical analysis (1/7/2019)

The chemical analysis of the deposited weld metal in each test assembly is to be supplied by the manufacturer, and is to include the content of all significant alloying elements.

6.2.4 Mechanical tests (1/7/2019)

On each assembly, tests are to be made in accordance with [4.2.3] and the results are to comply with the requirements of [4.2.4], appropriate to the required grade.

6.2.5 Preparation of butt weld assemblies (1/7/2019)

Butt weld assemblies as shown in Fig 2 are to be prepared for each welding position (downhand, horizontal-vertical, vertical upwards, vertical downwards and overhead) for which the wire or wire-gas combination is recommended by the manufacturer.

The downhand assembly is to be welded using, for the first run, wire of the smallest diameter to be approved and, for the remaining runs, wire of the largest diameter to be approved.

Where approval is requested only in the downhand position, an additional butt weld assembly is to be prepared in that position using wires of different diameter from those required in this Article. Where only one diameter is manufactured, only one downhand butt weld assembly is to be prepared.

The butt weld assemblies in positions other than downhand, are to be welded using, for the first run, wire of the smallest diameter to be approved, and, for the remaining runs, the largest diameter of wire recommended by the manufacturer for the position concerned.

6.2.6 Radiographic examination (1/7/2019)

It is recommended that the welded assemblies are subjected to radiographic examination to ascertain if there are any defects in the welds prior to the preparation of test specimens.

6.2.7 (1/7/2019)

On each assembly, tests are to be made in accordance with [4.3.4], and the results are to comply with the requirements of [4.3.5].

6.2.8 Fillet weld tests (1/7/2019)

Fillet weld test assemblies are required to be made in accordance with [4.6.1] and [4.6.2], and tested in accordance with [4.6.3].

6.3 Approval for automatic multi-run welding

6.3.1 General (1/7/2019)

Approval tests for automatic multi-run welding are to be carried out generally in accordance with [5] multi-run approval, except as required by [5.2], using the automatic

multi-run technique for the preparation of all test assemblies.

6.3.2 Preparation of deposited metal assembly (1/7/2019)

One deposited metal assembly is to be prepared as shown in Fig 5. Welding is to be as detailed in [5.2.2], except that the thickness of each layer is to be not less than 3 mm.

6.3.3 Chemical analysis (1/7/2019)

The chemical analysis of the deposited weld metal in this test assembly is to be supplied by the manufacturer, and is to include the content of all significant alloying elements.

6.3.4 Mechanical tests (1/7/2019)

Tests on this assembly are to be made in accordance with [5.2.2], and the results are to comply with the requirements of [5.2.2].

6.3.5 Preparation of butt weld assemblies (1/7/2019)

One butt weld assembly is to be prepared in each welding position which is to be approved. Generally, this will be the downhand position only, in which case only one assembly is required. Preparation of the assembly is to be in accordance with [5.2.3].

6.3.6 Radiographic examination (1/7/2019)

It is recommended that each assembly be subjected to a radiographic examination to ascertain any defect in the weld prior to testing.

6.3.7 Mechanical tests (1/7/2019)

Tests are to be made on each assembly in accordance with [5.2.3] and the results are to comply with the requirements of Tab 10. Where more than one assembly is prepared and tested, the number of transverse tensile and bend test specimens from each assembly may be halved.

6.3.8 Discretionary approval (1/7/2019)

At the discretion of the Society, wires or wire-gas combinations approved for semi-automatic multi-run welding may also be approved, without additional tests, for automatic multi-run welding approval.

This is generally the case when automatic multi-run welding is performed in the same conditions of welding current and energy as semi-automatic welding with the concerned wire-gas combination.

The only difference between the two welding processes in this case is that the welding gun is held by an automatic device instead of the welder's hand.

6.4 Approval for automatic two-run welding

6.4.1 General (1/7/2019)

Approval tests for automatic two-run welding are to be carried out generally in accordance with the requirements of [5.3], except as required by this Article, using the automatic two-run welding technique for the preparation of all test assemblies.

6.4.2 Preparation of butt weld assemblies (1/7/2019)

Two butt weld test assemblies are to be prepared, generally as detailed in [5.3.1] and [5.3.2], using plates 12-15 mm

and 20-25 mm in thickness. If approval is requested for welding plate thicker than 25 mm, one assembly is to be prepared using plates approximately 20 mm in thickness and the other using plates of the maximum thickness for which approval is requested.

The plate preparation of the test assemblies is to be as shown in Fig 9. Small deviations in the edge preparation may be allowed, if requested by the manufacturer. For assemblies using plates over 25 mm in thickness, the edge preparation is to be reported for information. Deviations or variations will be expected to form part of the manufacturer's standard recommended procedure for this technique and thickness range.

The diameters of wires used are to be in accordance with the recommendations of the manufacturer and are to be reported.

6.4.3 Radiographic examination (1/7/2019)

It is recommended that the welded assemblies be subjected to radiographic examination to ascertain any defect in the weld prior to testing, and to confirm full penetration continuously along the major part of the welded length of each assembly.

Figure 9 : Recommended edge preparation for two-run butt weld test assemblies (1/7/2019)

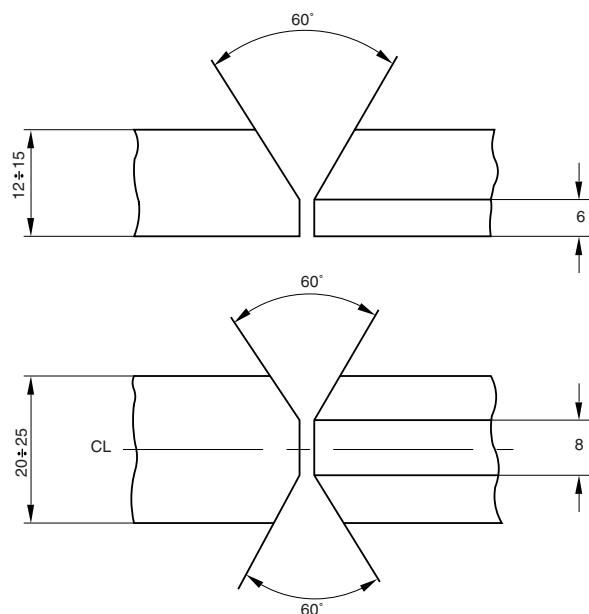

6.4.4 Mechanical tests (1/7/2019)

Tests are to be made on each assembly in accordance with [5.3.2] and the results are to comply with the requirements of [5.2.2] and Tab 10.

6.4.5 Chemical analysis (1/7/2019)

The chemical analysis of the deposited weld metal on the second side welded, is to be reported for each assembly.

6.5 Annual tests and up-grading

6.5.1 Annual tests (1/7/2019)

Annual tests are to consist of at least:

- Wires approved for semi-automatic or both semi-automatic and automatic multi-run welding: one deposited metal test assembly prepared in accordance with [6.2.2] using a wire of diameter within the range approved for the semi-automatic multi-run welding of ship structures.
- Wires approved for automatic multi-run welding: one deposited metal test assembly prepared in accordance with [6.3.2] using a wire of diameter within the range approved for automatic multi-run welding of ship structures.
- Wires approved for automatic two-run welding: one butt weld test assembly prepared in accordance with [6.4.2] using plates of 20-25 mm in thickness. The wire diameter used is to be reported.

The test specimens are to be prepared and tested in accordance with the requirements of [6], except that only the following tests are required:

- For deposited metal assemblies (semi-automatic and automatic multi-run): one tensile and three impact tests.
- For butt weld assemblies (automatic two-run): one transverse tensile, two bend and three impact tests. One longitudinal tensile test is also required where the wire is approved solely for automatic two-run welding.

Note 1: At the discretion of the Society, hydrogen test can be carried out following [4.5].

6.5.2 Up-grading and up-rating (1/7/2019)

Up-grading of flux cored wires and wire-gas combinations in connection with the impact properties will be considered as detailed in [4.8.2] b).

Up-rating of flux cored wires and wire-gas combinations with the tensile properties will be considered as detailed in [4.8.2] c).

7 Consumables for use in electroslag and electrogas vertical welding

7.1 General

7.1.1 (1/7/2019)

The requirements for the two-run technique as detailed in [5] are applicable for the approval of special consumables used in electro-slag and electro-gas vertical welding with or without consumable nozzles except as otherwise required by the following requirements especially as regards the number and kind of the test-pieces used for the mechanical tests and taken from the butt welded assemblies.

7.1.2 (1/7/2019)

For Grades 1Y, 2Y, 3Y, 4Y, 2Y40, 3Y40, 4Y40 and 5Y40 approval of the consumables may be restricted for use only with specific types of higher strength steel. This is in respect of the content of grain refining elements, and if general approval is required, a niobium treated steel is to be used for the approval tests.

7.1.3 (1/7/2019)

For these special welding consumables, the prescription [1.2.1] may not be entirely applicable for technical reasons. Where approval is requested for welding of both normal strength and higher strength steel two assemblies are to be prepared using higher strength steel. Two assemblies prepared using normal strength steel may also be required at the discretion of the Society.

7.2 Butt weld tests

7.2.1 Preparation of test assemblies (1/7/2019)

Two butt weld test assemblies are to be prepared, one of them with plates 20/25 mm thick, the other with plates 35/40 mm thick or more. The grade of the steel to be used for each one of these assemblies must be selected according to the requirements given in Tab 12 for two-run submerged arc welding.

The chemical composition of the plate, including the content of grain refining elements is to be reported.

The welding conditions and the edge preparation are to be those recommended by the welding consumable manufacturer and are to be reported.

7.2.2 Radiographic examination (1/7/2019)

It is recommended that the welded assemblies be subjected to a radiographic examination to ascertain if there are any defects in the weld prior to the preparation of test specimens.

7.2.3 Test series (1/7/2019)

Each assembly shall be cut to give test specimens according to Fig 10.

The length of the assembly should be sufficient to allow the selection of all the test specimens:

- a) 2 longitudinal tensile test specimens with their axis at the centre of the weld
- b) 2 transverse tensile test specimens
- c) 2 side bend test specimens
- d) 2 sets of 3 Charpy-V notch impact test specimens in accordance with Fig 10:
 - set with the notch in the axes of the weld,
 - set with the notch at 2 mm from the fusion line in the deposited metal,
- e) 2 macro-sections to the weld (towards the middle of the weld and towards one end).

7.2.4 Results to be obtained (1/7/2019)

The results of the tensile, bend and impact tests are to comply with the requirements of [5.3] (two-run welding) for the class of filler product in question.

7.3 Annual tests and up-grading

7.3.1 (1/7/2019)

All factories which manufacture approved consumables for use in electroslag and electrogas welding must be subject to an annual inspection and tests in accordance with [2.4].

7.3.2 (1/7/2019)

One test assembly must be prepared from plates 20/25 mm thick, and tested as indicated in [7.2].

The following specimens are to be selected:

- a) 1 longitudinal tensile specimen from the axis of the weld,
- b) 1 transverse tensile specimen,
- c) 2 side bend specimens,
- d) 3 Charpy-V specimens notched at the centre of the weld (position 1 Fig 10),
- e) 3 Charpy-V specimens cut out transverse to the weld with their notches at 2 mm from the fusion line, in the weld,
- f) macro section.

7.3.3 (1/7/2019)

The results to be obtained should meet the requirements given in [5.3] (two-run welding) for the class of the consumables in question.

7.3.4 Upgrading and uprating (1/7/2019)

Upgrading and uprating will be considered only at the manufacturers' request, at the time of annual testing. Generally, for this purpose, full tests from butt weld assemblies as indicated in [7.2] will be required, irrespective of the other tests requested if the concerned consumable is also approved (and possibly upgraded or uprated) according to [5] or [6].

Figure 10 : Electroslag and electrogas butt weld test assembly (1/7/2019)

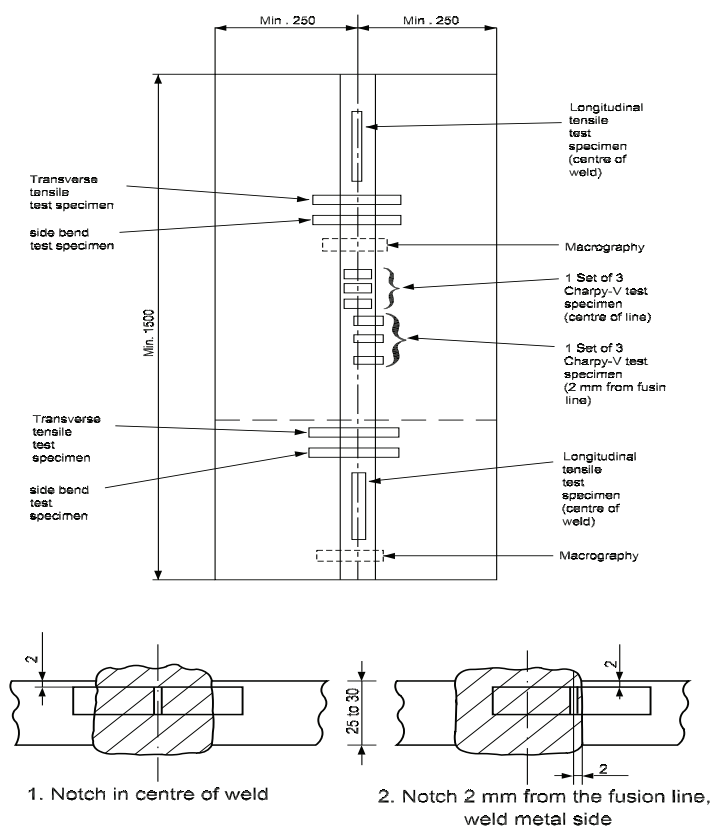

8 Approval of Welding Consumables for High Strength Steels for Welded Structures

8.1 Application

8.1.1 (1/7/2019)

The requirements of this Article apply to consumables used for weldable high strength steels for welded structures with minimum specified yield strength from 420 N/mm² to 960 N/mm², and impact grades A, D, E and F, except that impact grade F is not applicable for 890 N/mm² and 960 N/mm² yield strength levels.

Unless otherwise stated in this Article, the requirements relevant to the procedure, tests samples and welding conditions are generally to be in accordance with those of the previous Articles relevant to the approval of consumables for welding normal and higher strength hull structural steels, as follows:

- Article [4]: Covered electrodes for manual metal arc welding;
- Article [5]: Flux-wire combination for submerged arc welding;
- Article [6]: Wires and wire-gas combination for semiautomatic and automatic welding processes employing continuous wire.

The welding consumables preferably to be used for the steels concerned are divided into several categories as follows:

- covered electrodes for manual welding,
- wire-flux combinations for multi-run (see Note 1) submerged arc welding,
- solid wire-gas combinations for arc welding (including rods for gas tungsten arc welding),
- flux cored wire with or without gas for arc welding.

Note 1: Wire-flux combinations for single or two-run technique are subject to special consideration of the Society.

8.2 Grading and designation

8.2.1 (1/7/2019)

Based on the yield strength of the weld metal, the welding consumables concerned are divided into eight (yield) strength groups:

- Y42 - for welding steels with minimum yield strength 420 N/mm²
- Y46 - for welding steels with minimum yield strength 460 N/mm²
- Y50 - for welding steels with minimum yield strength 500 N/mm²
- Y55 - for welding steels with minimum yield strength 550 N/mm²
- Y62 - for welding steels with minimum yield strength 620 N/mm²

- Y69 - for welding steels with minimum yield strength 690 N/mm²
- Y89 - for welding steels with minimum yield strength 890 N/mm²
- Y96 - for welding steels with minimum yield strength 960 N/mm²

8.2.2 (1/7/2019)

Each of the eight (yield) strength groups is further divided into three main grades (3, 4 and 5) in respect of Charpy V-notch impact test requirements (test temperatures):

- Grade 3, test temperature -20°C
- Grade 4, test temperature -40°C
- Grade 5, test temperature -60°C

8.2.3 (1/7/2019)

Analogously to the designation scheme used in previous Articles the welding consumables for high strength steels are subject to classification designation and approval as follows:

- with the quality grades 3, 4 or 5 according to [8.2.2];
- with the added symbol 'Y' followed by a number designating the minimum yield strength of the weld metal corresponding to [8.2.1];
- with the added symbol 'H10' or 'H5' for controlled hydrogen content of the weld metal;
- with the added symbol 'S' (semi-automatic) for semi-mechanised welding;
- with the added symbol 'M' designating multi-run technique (see Note 1) (applicable only to welding consumables for fully mechanised welding).

Note 1: Wire-flux combinations for single or two-run technique are subject to special consideration of the Society.

8.2.4 (1/7/2019)

Each higher quality grade includes those below. Grade A and D steels according to Pt D, Ch 2, Sec 1, [3] are to be welded using welding consumables of at least quality grade 3; grade E steels using at least quality grade 4; grade F steels using at least quality grade 5. Reference is to be made to Tab 14.

Welding consumables approved with grades Y42, Y46 and Y50 are also considered suitable for welding steels in the two strength levels below that for which they have been approved. Welding consumables approved with grades Y55, Y62 and Y69 are also considered suitable for welding steels in the one strength level below that for which they have been approved.

Welding consumables with grade Y89 are considered suitable for welding steels in the same strength level only. Welding consumables with grade Y96 are also considered suitable for welding steels in the one strength level below that for which they have been approved.

For grades Y89 and Y96, where the design requirements permit undermatching weld joint, then welding consumables within the scope of this Article can be considered subject to Society discretion and Manufacturer's recommendations.

The Society may, in individual cases, restrict the range of application in (up to) such a way, that approval for any one strength level does not justify approval for any other strength level.

Table 14 : Matching steels grades and consumables (1/7/2019)

Consumable Grade	Steel Grades covered
3Y	D and A
4Y	E, D and A
5Y	F, E, D and A

8.3 Manufacture, testing and approval procedure

8.3.1 Quality control and approval procedure (1/7/2019)

Manufacturer's plant, production methods and quality control measures is to be such as to ensure reasonable uniformity in manufacture.

Testing and approval procedure is to be in accordance with [2] and [3] and from [4] to [7] as required for the individual categories (types) of welding consumables mentioned in [8.2.1] above.

8.3.2 Testing of the weld metal (1/7/2019)

For testing the deposited weld metal, test pieces analogous to those called for in [4.2], [5.2], [6.2] [6.2] or [6.3] respectively is to be prepared, depending on the type of the welding consumables (and according to the welding process). The base metal used is to be a fine-grained structural steel compatible with the properties of the weld metal, or the side walls of the weld is to be buttered with a weld metal of the same composition.

The chemical composition of the deposited weld metal is to be determined and certified in a manner analogous to that prescribed in [4.2.2]. The results of the analysis is to be not exceed the limit values specified in the standards or by the manufacturer, the narrower tolerances being applicable in each case.

Depending on the type of the welding consumables (and according to the welding process), the test specimens prescribed in [3.1] and [4.2], [5.2], [6.2] or [6.3] respectively is to be taken from the weld metal test pieces in a similar manner.

The mechanical properties must meet the requirements stated in Tab 15. The provisions of previous articles of this Section apply in analogous manner to the performance of the tests, including in particular the maintenance of the test temperature in the notched bar impact test and the carrying out of results.

8.3.3 Testing on welded joints (1/7/2019)

Depending on the type of the welding consumables (and according to the welding process), the testing on the welded joints is to be performed on butt-weld test pieces in analogous manner to [4.3], [5.2], [6.2], [6.3], or [6.4] respectively.

Depending on the type of the welding consumables (and according to the welding process), the butt-weld test pieces called for in this Article is to be welded in a manner analogous to that prescribed in the previous Articles of this Section. The base metal used is to be a high-strength fine-grained structural steel with minimum yield strength and tensile strength matching the consumable grade being approved and compatible with the added symbol for which application is made.

Depending on the type of the welding consumables (and according to the welding process), the test specimens described in the previous Articles of this Section are to be taken from the butt-weld test pieces.

The mechanical properties must meet the requirements stated in Tab 15. The provisions of the previous Articles of this Section apply in analogous manner to the performance of the tests, including in particular the maintenance of the test temperatures in the notched bar impact test and the requirements regarding the retest specimens.

Where the minimum bending angle of 120° required in Tab 15 is not achieved, the specimen may be considered as fulfilling the requirements, if the bending elongation on a gauge length L_0 fulfills the minimum elongation requirements stated in Tab 15.

The gauge length $L_0 = L_s + t$ (L_s = width of weld, t = specimen thickness), see Fig 11.

Figure 11 : Bending elongation (1/7/2019)

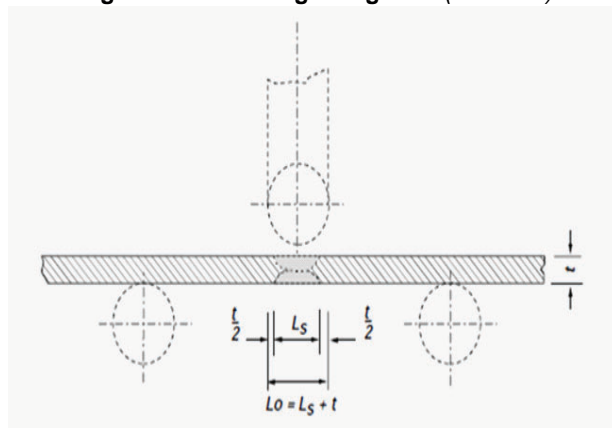

8.4 Hydrogen test

8.4.1 (1/1/2023)

The welding consumables, other than solid wire-gas combinations, are to be subjected to a hydrogen test in accordance with the mercury method to ISO 3690:2018, or any other method such as the gas chromatographic method which correlates with that method, in respect of cooling rate and delay times during preparation of the weld samples, and the hydrogen volume determinations.

8.4.2 (1/7/2019)

The diffusible hydrogen content of the weld metal determined in accordance with the provisions of [4.5] is not to exceed the limits given in Tab 16.

8.5 Annual repeat test

8.5.1 (1/7/2019)

The annual repeat tests specified in the previous Articles of this Section are to entail the preparation and testing of weld metal test pieces as prescribed under [8.3.2].

For grades Y69 to Y96 annual hydrogen test is required.

In special cases, the Society may require more extensive repeat tests.

Table 15 : Mechanical properties (1/7/2019)

Grade	Tensile test on deposited metal			Tensile test on butt weld	Charpy V-notch impact test		Bend ratio and angle	
	Yield stress R_{eH} (N/mm ²) min.	Tensile strength R_m (N/mm ²) min.	Elong. A_5 (%) min.	Tensile strength R_m (N/mm ²) min.	Test temp. (°C)	Minimum average energy (J) (1)	D/t (3) α (4) $\geq 120^\circ$	
3	Y42	420	520-680	20	520	-20	47	4
4						-40		
5						-60		
<p>(1) Charpy V-notch impact test specimen, mean value of three specimens; for requirements regarding minimum individual values and retests, see [3.2.4] and [3.3.2].</p> <p>(2) Quality grade 5 is not applicable for Y89 and Y96 grade consumables.</p> <p>(3) D = mandrel diameter, t = specimen thickness.</p> <p>(4) Bending angle attained before the first incipient crack, minor pore exposures up to a maximum length of 3mm allowed.</p>								

Grade		Tensile test on deposited metal			Tensile test on butt weld	Charpy V-notch impact test		Bend ratio and angle
		Yield stress R_{eH} (N/mm ²) min.	Tensile strength R_m (N/mm ²) min.	Elong. A_5 (%) min.	Tensile strength R_m (N/mm ²) min.	Test temp. (°C)	Minimum average energy (J) (1)	D/t (3) α (4) $\geq 120^\circ$
3	Y46	460	540-720	20	540	-20	47	4
4						-40		
5						-60		
3	Y50	500	590-770	18	590	-20	50	4
4						-40		
5						-60		
3	Y55	550	640-820	18	640	-20	55	5
4						-40		
5						-60		
3	Y62	620	700-890	18	700	-20	62	5
4						-40		
5						-60		
3	Y69	690	770-940	17	770	-20	69 (2)	5
4						-40		
5						-60		
3	Y89	890	940-1100	14	940	-20	69	6
4						-40		
3	Y96	960	980-1150	13	980	-20	69	7
4						-40		

(1) Charpy V-notch impact test specimen, mean value of three specimens; for requirements regarding minimum individual values and retests, see [3.2.4] and [3.3.2].

(2) Quality grade 5 is not applicable for Y89 and Y96 grade consumables.

(3) D = mandrel diameter, t = specimen thickness.

(4) Bending angle attained before the first incipient crack, minor pore exposures up to a maximum length of 3mm allowed.

Table 16 : Allowable diffusible hydrogen content (1/7/2019)

Yield strength group	Hydrogen symbol	Maximum hydrogen content [cm ³ /100 g deposited weld metal]
Y42	H 10	10
Y46		
Y50		
Y55	H 5	5
Y62		
Y69		
Y89	H 5	5
Y96		

9 Consumables for welding Mo and Cr-Mo steels

9.1 Application

9.1.1 General (1/7/2019)

The requirements of this Article apply to consumables used for welding Mo and Cr-Mo steels.

Unless otherwise stated in this Article, the requirements relevant to the procedure, tests samples and welding conditions are generally to be in accordance with those of the previous Articles relevant to the approval of consumables for welding carbon and carbon-manganese steels, as follows:

- Article [4]: Covered electrodes for manual metal arc welding
- Article: [5] Flux-wire combination for submerged arc welding
- Article [6]: Wires and wire-gas combinations for metal arc welding.

9.1.2 Grading

Consumables are divided into the following grades, designated by a symbol indicating the nominal percentage Mo and Cr content of the deposited weld metal, as follows:

- M for Mo = 0,5
- C1M for Cr = 1,25 and Mo = 0,5
- C2M1 for Cr = 2,25 and Mo = 1

9.2 Approval tests

9.2.1 The same samples as for the C and C-Mn steel welding consumables approval are required.

The butt weld test samples are to be prepared using the corresponding grade of Mo or Cr-Mo steels.

Instead of the above-mentioned Mo and Cr-Mo steels, at the request of the Manufacturer, grades 460 and 510 C-Mn steels for boilers and pressure vessels may be used.

9.2.2 When the approval is required for two types of the same consumable, one with normal C content and the other with "low C" content, i.e. with C content not higher than 0,05%, and if the Manufacturer certifies that the only difference is the C content, for the approval of "low C" welding consumables the tests for checking the mechanical properties of the deposited material and the chemical composition only are to be carried out.

9.2.3 With the exception of those for the hydrogen content checking, the test samples are to be welded in the preheating condition and are to be post-weld heat treated,

as indicated in Tab 17, depending on the grade of the consumable.

Table 17 : Pre- and post-weld heating

Consumable grade	M	C1M	C2M1
Preheating:			
Temperature (°C)	-	100 - 150	200 - 280
Post-weld heat treatment:			
Temperature T (°C)	620 ± 10	660 ± 10	710 ± 10
Soaking time at T (minutes)	30	30	60
Cooling rate down to 500°C (°C/h) in furnace (1)	150 - 250	150 - 250	100 - 200
(1) When 500°C is reached, the cooling may be continued either in the furnace or in still air.			

9.2.4 In the case of covered electrodes for manual welding, the checking of the chemical composition is to be carried out, as a rule, on samples of deposited metal described in [4.2].

Two samples are required with two different electrode diameters.

In the case of other types of welding consumables, the checking is to be carried out on shavings taken from the deposited metal samples.

The checking of C, Cr and Mo contents is to be carried out on all the samples and, additionally, the checking of Mn, Si, Cu, Ni, S and P contents and that of other alloy elements is to be carried out on one sample.

9.2.5 Consumables may be submitted, at the Manufacturer's request, to hydrogen tests and have the additional symbol H10 (or HH) or H5 added to the grade designation according to the hydrogen content.

9.3 Test requirements

9.3.1 (1/7/2019)

In the tests for checking the mechanical properties, the requirements specified in Tab 18 are to be met.

As a rule, transverse tensile tests on the welded joint are not required.

9.3.2 In the tests for checking the chemical composition, the limits in percentage of chemical composition specified in Tab 19 are to be met.

Table 18 : Mechanical properties

Grade	Tensile test on deposited metal (1)		Bend ratio and angle (2)
	Tensile strength R_m (N/mm ²)	Elong. A_5 (%) min.	D/ t $\alpha \geq 120^\circ$
M	490 - 640	20	3
C1M	490 - 690	20	3
C2M1	540 - 785	18	4

(1) The values of the minimum yield strength R_{eH} and reduction of area are also to be recorded, for information purposes.
(2) D = mandrel diameter, t = specimen thickness.

9.4 Periodical control tests

9.4.1 (1/7/2006)

For the periodical control tests, to be carried out as a rule every year, in addition to the samples and tests for checking the mechanical properties, as required for the consumables for welding C and C-Mn steels, the samples for checking the chemical composition, requested for the approval, are to be effected.

9.4.2 For the "low C" welding consumables described in [9.2.2], the control tests are limited to one sample of deposited metal [4.2] and to the checking of the chemical composition.

10 Consumables for welding Ni steels for low temperature applications

10.1 Application

10.1.1 General (1/7/2019)

The requirements of this Article apply to consumables used for welding Ni steels for low temperature applications.

Unless otherwise stated in this Article, the requirements relevant to the procedure, tests samples and welding

conditions are generally to be in accordance with those in the previous Articles relevant to the approval of consumables for welding carbon and carbon-manganese steels, as follows:

- Article [4]: Covered electrodes for manual metal arc welding
- Article [5]: Flux-wire combination for submerged arc welding
- Article [6]: Wires and wire-gas combinations for metal arc welding.

10.1.2 Grading

Consumables are divided into the following grades designated by a symbol indicating the type of nickel steel for which the consumables are intended, as follows:

- N15 for steels with Ni = 1,30 - 1,70 (%)
- N35 for steels with Ni = 3,25 - 3,75 (%)
- N50 for steels with Ni = 4,75 - 5,25 (%)
- N90 for steels with Ni = 8,50 - 10 (%)

10.2 Approval tests

10.2.1 The same samples as for the C and C-Mn steel welding consumables approval are required.

The butt weld test samples are to be prepared using the corresponding grade of Ni steel.

Instead of the above-mentioned Ni steel, at the request of the Manufacturer, steels with lower Ni content but having suitable mechanical properties for the tests to be carried out may be used. In such case, if deemed necessary by the Manufacturer, the bevels may be duly buttered with the welding consumable to be approved.

In the case of use of plates with buttered bevels and where the mechanical properties of the welding consumable are significantly lower than those of the base material, longitudinal instead of transverse specimens may be allowed to be taken for face and root bend tests. In this case the length of the sample is to be such as to allow the taking of these specimens.

Table 19 : Chemical composition

Grade	Chemical composition (%)								
	C	Cr	Mo	Mn	Si max.	S max.	P max.	Cu max.	Ni max.
M	0,12 (1)	0,15	0,40 - 0,65	0,50 - 0,90 (2)	0,60 (2)	0,040	0,040	0,20	0,30
C1M	0,12 (1)	1,0 - 1,5	0,40 - 0,65						
C2M1	0,10 (1)	2,0 - 2,5	0,90 - 1,20						

(1) In the case of electrodes to be certified as "low carbon " the carbon content is not to exceed 0,05%.
(2) The actual values of Mn and Si contents, guaranteed by the Manufacturer, within the limits specified in the table, are to be stated at the time of the approval of single electrodes.

10.2.2 In the case of covered electrodes for manual welding, the checking of the chemical composition is to be carried out, as a rule, on samples of deposited metal described in [4.2].

Two samples are required with two different electrode diameters.

In the case of other types of welding consumables, the checking is to be carried out on shavings taken from the deposited metal samples.

The checking of C, Ni, Mn and Si contents is to be carried out on all the samples and, additionally, the checking of Cu, Cr, S, P and other alloy elements is to be carried out on one sample.

10.2.3 Consumables may be submitted, at the Manufacturer's request, to hydrogen tests and have the additional symbol H10 (or HH) or H5 added to the grade designation according to the hydrogen content.

10.2.4 Unless special requests are made by the Manufacturer, the samples are not to be post-weld heat treated.

10.3 Tests requirements

10.3.1 (1/7/2019)

In the tests for checking the mechanical properties, the requirements specified in Tab 20 are to be met.

As a rule, transverse tensile tests on the welded joint are not required.

10.3.2 In the tests for checking the chemical composition, the limits in percentage of chemical composition specified and guaranteed by the Manufacturer are to be met.

10.4 Annual control tests

10.4.1 For the periodical control tests, in addition to the samples and tests for checking the mechanical properties as required for the consumables for welding C and C-Mn steels, the samples for checking the chemical composition, requested for the approval, are to be effected.

11 Consumables for welding Cr-Ni austenitic and austenitic-ferritic stainless steels

11.1 Application

11.1.1 General (1/7/2019)

The requirements of this Article apply to consumables used for welding Cr-Ni austenitic and austenitic-ferritic stainless steels.

Unless otherwise stated in this Article, the requirements relevant to the procedure, tests samples and welding conditions are, in general, to be in accordance with those in the previous Articles relevant to the approval of consumables for welding carbon and carbon-manganese steels, as follows:

- Article [4]: Covered electrodes for manual metal arc welding
- Article [5]: Flux-wire combination for submerged arc welding
- Article [6]: Wires and wire-gas combinations for metal arc welding.

11.1.2 Grading

Consumables intended for welding austenitic steels are divided into the following grades designated by a symbol corresponding to the AWS designation of the weld metal, as follows: 308, 308L, 316, 316L, 316LN, 317, 317L, 309, 309L, 309Mo, 310, 310Mo, 347.

The additional symbol BT is added when the requirements on impact test energy are satisfied at the temperature of -196°C.

Consumables intended for welding austenitic-ferritic steels are designated by a symbol indicating the nominal percentage content of Cr and Ni in the deposited metal (e.g. 2205 means 22% Cr and 5% Ni).

Table 20 : Mechanical properties

Grade	Tensile test on deposited metal			Tensile test on butt weld	Charpy V-notch impact test		Bend ratio and angle
	Yield stress R_{eH} (N/mm ²) min.	Tensile strength R_m (N/mm ²) min.	Elong. A_5 (%) min.	Tensile strength R_m (N/mm ²) min.	Test temp. (°C)	Minimum average energy (J)	D/t (1) $\alpha \geq 120^\circ$
N 15	355	470	22	490	- 80	34	3
N 35	355	470	22	490	- 100	34	3
N 50	380	520	22	540	- 120	34	4
N 90	480	670	22	690	- 196	34	4

(1) D = mandrel diameter, t = specimen thickness

11.2 Approval tests

11.2.1 The same samples as for the C and C-Mn steel welding consumables approval are required, with the exception of samples for hydrogen content checking.

The all deposited metal and the butt weld test samples are to be prepared using the corresponding grade of stainless steel.

However, at the request of the Manufacturer, the all deposited metal may be allowed to be prepared using C and C-Mn steels, provided that the bevels are duly buttered with the welding consumable to be approved.

11.2.2 When the approval is required for two types of the same welding consumable, one with normal C content and one with "low C" content, for the approval of "low C" welding consumables the tests for checking the mechanical properties of the deposited material and the chemical composition only are to be carried out.

11.2.3 In the case of covered electrodes for manual welding, the checking of the chemical composition is to be carried out, as a rule, on samples of deposited metal and described in [4.2].

One sample is required for each electrode diameter to be approved.

In the case of other types of welding consumables, the checking is to be carried out on shavings taken from the deposited metal samples.

The checking of C, Cr, Ni contents is to be carried out on all the samples, in addition to Mo, Nb and N contents where

such elements characterise the welding consumable being tested. For only one of the diameters tested, the chemical analysis of the remaining elements listed in Tab 22 is also to be carried out.

11.2.4 For consumables for welding austenitic-ferritic steels, the ratio ferrite/austenite is also to be determined in the all deposited material.

11.2.5 Corrosion tests according to ASTM A262 Practice E, ASTM G48 Method A or equivalent recognised standards may be required, on a case-by-case basis, for austenitic and duplex stainless steel consumables.

11.2.6 Unless special requests are made by the Manufacturer, the samples are not to be post-weld heat treated.

Table 21 : Required mechanical properties

Grade	Tensile test on deposited metal			Tensile test on butt weld	Charpy V-notch impact test		Bend ratio and angle
	Yield stress $R_{p0,2}$ (N/mm ²) min.	Tensile strength R_m (N/mm ²) min.	Elong. A_5 (%) min.	Tensile strength R_m (N/mm ²) min.	Test temp. (°C)	Minimum average energy (J)	D/t (1) $\alpha \geq 120^\circ$
Austenitic							
308	290	540	25	515	-20 (2)	27	3
308L	275	490	25	485			
316	290	540	25	515			
316L	275	490	25	485			
316LN	290	540	25	515			
317	290	540	25	515			
317L	275	490	25	515			
309	290	540	22	515			
309L	275	490	22	515			
309Mo	290	540	22	515			
310	290	540	25	515			
310Mo	290	540	25	515			
347	290	540	25	515			
Austenitic-ferritic							
-	480	680	25	680	-20	27	3
(1) D = mandrel diameter, t = specimen thickness							
(2) The impact test temperature is -20°C, except when the additional symbol BT is required, in which case the test is to be carried out at -196°C.							

Table 22 : Chemical composition

Grade	Chemical composition (%)					
	C	Mn	Cr	Ni	Mo	Others
308	≤ 0,08	0,5 - 2,5	18 - 21	8 - 11	≤ 0,75	
308L	≤ 0,04	0,5 - 2,5	18 - 21	8 - 11	≤ 0,75	
316	≤ 0,08	0,5 - 2,5	17 - 20	11 - 14	2 - 3	
316L	≤ 0,04	0,5 - 2,5	17 - 20	11 - 14	2 - 3	
316LN	≤ 0,04	0,5 - 2,5	17 - 20	10 - 14	2 - 3	0,15 ≤ N ≤ 0,20
317	≤ 0,08	0,5 - 2,5	17 - 21	11 - 14	2,5 - 4	
317L	≤ 0,04	0,5 - 2,5	17 - 21	11 - 14	2,5 - 4	
309	≤ 0,15	0,5 - 2,5	22 - 26	11 - 15	≤ 0,75	
309L	≤ 0,04	0,5 - 2,5	22 - 26	11 - 15	≤ 0,75	
309Mo	≤ 0,12	0,5 - 2,5	22 - 26	11 - 15	2 - 3	
310	0,08 - 0,20	1,0 - 2,5	25 - 28	20 - 22,5	≤ 0,75	
310Mo	≤ 0,12	1,0 - 2,5	25 - 28	20 - 22	2 - 3	
347	≤ 0,08	0,5 - 2,5	18 - 21	9 - 11	≤ 0,75	8xC ≤ Nb+Ta ≤ 1

11.3 Test requirements

11.3.1 (1/7/2019)

In the tests for checking the mechanical properties, the requirements specified in Tab 25 are to be met.

For consumables intended for welding Cr-Ni austenitic steels for which the approval is required with the additional symbol BT, the requirements on adsorbed energy in the impact test specified in the table are to be satisfied at the temperature of -196°C.

11.3.2 In the tests for checking the chemical composition of welding consumables intended for Cr-Ni austenitic steels, the limits in percentage specified in Tab 22 are to be satisfied.

In the tests for checking the chemical composition of welding consumables intended for austenitic-ferritic steels, the limits in percentage specified and guaranteed by the Manufacturer are to be satisfied.

11.4 Annual control tests

11.4.1 For the periodical control tests, in addition to the samples and tests for checking the mechanical properties as required for the consumables for welding C and C-Mn steels, the samples for checking the chemical composition are also to be effected.

11.4.2 For the "low C" welding consumables described in [11.2.2], the control tests are limited to one sample of deposited metal and to the checking of the chemical composition.

12 Consumables for welding aluminium alloys

12.1 Application

12.1.1 General (1/1/2023)

The requirements of this Article apply to wire or rod-gas combinations to be used for welding the Al-Mg and Al-Si aluminium alloys specified in Ch 3, Sec 2.

(Unless otherwise stated in this Article, the requirements relevant to the procedure, tests samples and welding conditions are generally to be in accordance with those in Articles [6] relevant to the approval of consumables for welding with continuous wire process).

The welding consumables preferably to be used for the aluminium alloys concerned are divided into two categories, as follows:

- W = wire electrode and wire gas combination for metal-arc inert gas welding (MIG, 131 according to ISO 4063:2009), tungsten inert gas welding (TIG, 141) or plasma arc welding (PAW, 15)
- R = rod-gas combinations for tungsten inert gas welding (TIG, 141) or plasma arc welding (PAW, 15).

Note 1: For aluminium welding consumables, there is no unique relationship between the products (wire electrode, wire or rod) and the welding process used (TIG, MIG, PAW). Therefore the wire electrodes, wire or rods, in combination with the relevant shielding gas, will be approved on the basis of the above products form W and R and may be used, as appropriate, for one or more of the above processes.

12.1.2 Grading

The consumables are graded as specified in Tab 23 in accordance with the alloy type and strength level of the base materials used for the approval tests.

Table 23 : Consumable grades and base materials for the approval tests (1/7/2006)

Grade	Base material for the tests and alloy designation	
	Numerical	Chemical symbol
RA/ WA	5754	AlMg3
RB/ WB	5086	AlMg4
RC/ WC	5083	AlMg4,5Mn0,7
	5383	AlMg4,5Mn0,9
	5456	AlMg5
	5059	-
RD/ WD	6082	AlSiMgMn
	6005A	AlSiMg(A)
	6061	AlMg1SiCu

Note 1: Approval on higher strength AlMg base materials also covers the lower strength AlMg grades and their combination with AlSi grades.

12.1.3 Shielding gases

For the purpose of the approval, the type of gas and mixture of gas are grouped as indicated in Tab 24.

Table 24 : Composition of shielding gases (1/7/2006)

Group symbol	Gas composition in volume (%) (1)	
	Argon	Helium
I-1	100	-
I-2	-	100
I-3 (2)	Balance	> 0 to 33
I-3 (2)	Balance	> 33 to 66
I-3 (2)	Balance	> 66 to 95
S	Special gas composition to be specified	
(1)	Gases of other chemical composition (mixed gases) may be considered as special gases and are to be covered by separate tests	
(2)	Gas mixture to be used for the tests is as follows:	
	<ul style="list-style-type: none"> Group I-3(1): approx. 15% He Group I-3(2): approx. 50% He Group I-3(3): approx. 75% He 	

Unless otherwise required for specific applications, gas mixtures in the same group are considered equivalent for approval purposes.

Special gases in terms of composition or purity are to be designated with the group "S".

12.2 Approval tests

12.2.1 Deposited weld metal

For the testing of the chemical composition of the deposited weld metal, a test piece according to Fig 12 is to be prepared. The size depends on the type of the welding con-

sumable (and on the process used) and is to give a sufficient amount of pure metal for chemical analysis. The base metal is to be compatible with the weld metal in respect of chemical composition.

The checking of chemical composition may also be carried out on shavings taken from samples of test assembly in Fig 13.

The results of the analysis are not to exceed the limit values specified by the Manufacturer.

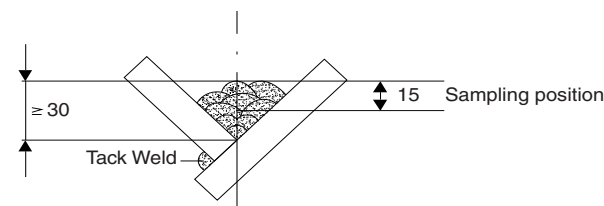
Figure 12 : Deposited weld metal test assembly

12.2.2 Butt weld test assembly

Butt weld test assemblies, in the material specified in Tab 23 and having thickness 10-12 mm, are to be prepared for each welding position (downhand, horizontal, vertical-upward and overhead) for which the consumable is recommended by the Manufacturer (see Fig 13); see also [12.2.3]. Subject to the agreement of the Society, consumables satisfying the requirements for the downhand and vertical-upward position will also be considered as complying with the requirements for the horizontal position.

12.2.3 Additional butt weld test assembly

One additional test assembly, having 20-25 mm, is to be welded in the downhand position (see Fig 14).

12.2.4 Post-weld condition

On completion of welding, the assemblies are to be allowed to cool naturally to ambient temperature. Welded test assemblies and test specimens are not to be subjected to any heat treatment. Grade D assemblies are to be allowed to naturally age for a minimum period of 72 hours from the completion of the welding and a maximum of one week, before testing is carried out.

12.3 Test requirements

12.3.1 It is recommended that the weld assemblies are subjected to radiographic examination to ascertain if there are any defects in the welds prior to the preparation of the test specimens.

In the tests for checking the operating characteristics, the requirements specified in Article [6] for wires for continuous wire processes are to be met.

The macro specimen is to be examined for defects such as cracks, lack of fusion, cavities, inclusions and pores. Cracks, lack of fusion or incomplete penetration are not allowed.

In the tests for checking the mechanical properties, the requirements specified in Tab 25 are to be met.

It is recommended that the bending test is performed with the "wrap around bending method" instead of the "free" bend test (see Fig 15).

12.4 Annual control tests

12.4.1 (1/1/2001)

For the periodical control tests, the butt weld test assembly in Fig 13 is to be carried out in downhand position using

the wire having the maximum approved diameter. Moreover the deposited weld metal test assembly (see Fig 12) is to be carried out.

Figure 13 : Butt weld test assembly for positional welding

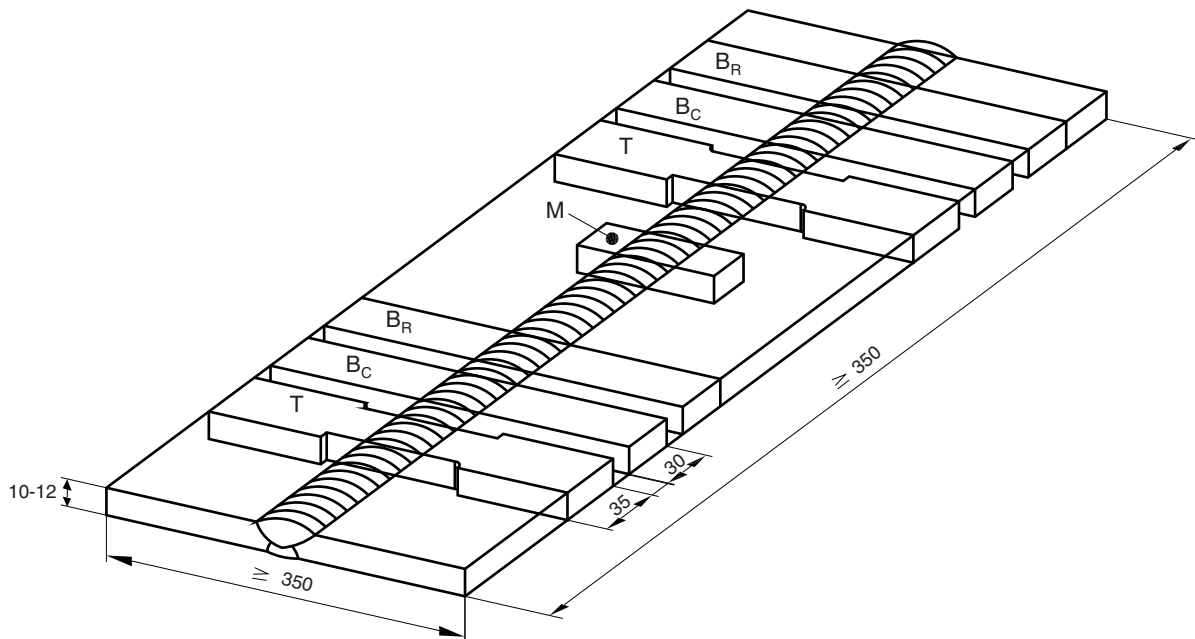

T = flat tensile test specimen; B_C = face bend test specimen; B_R = root bend test specimen; M = macrographic section

Figure 14 : Additional butt weld test assembly in downhand position

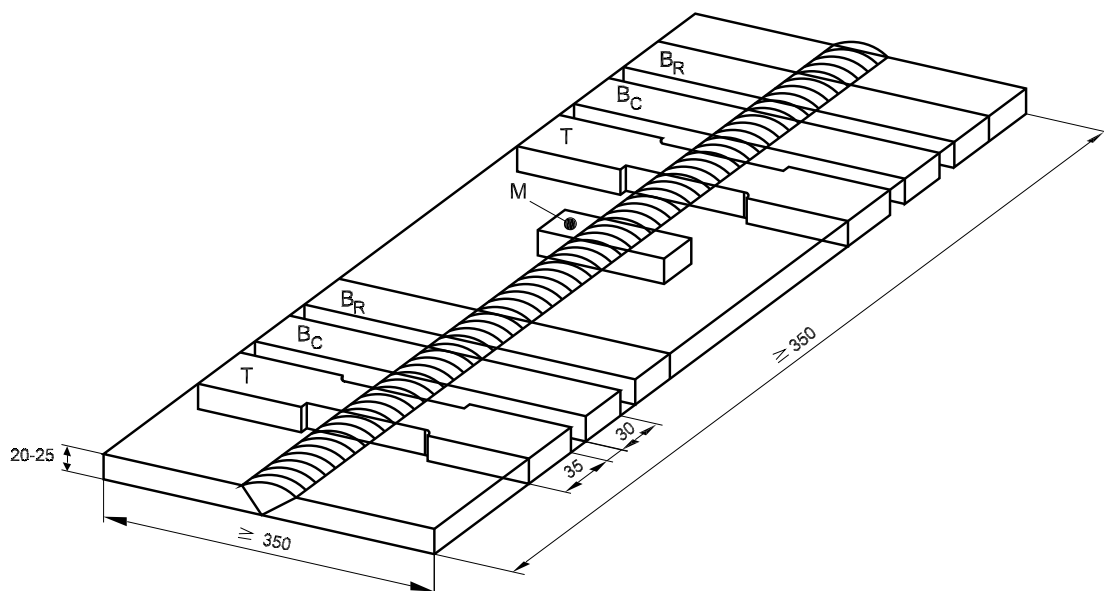

T = flat tensile test specimen; B_C = face bend test specimen; B_R = root bend test specimen; M = macrographic section

Figure 15 : Wrap around bend test

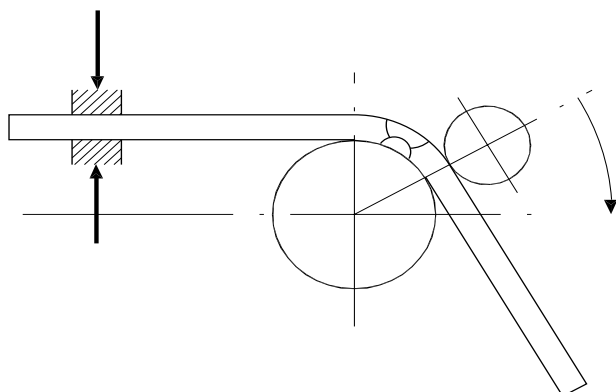

The fixed edge of the test specimen is to be clamped to avoid sliding. The whole welded zone (weld and heat affected zone), in the case of transverse bending, is to be entirely positioned in the bent zone.

Table 25 : Required mechanical properties (1/7/2006)

Grade	Base material used for the tests	Transverse tensile test	
		Tensile strength R_m (N/mm ²) min.	Bend ratio and angle D/ t (1) $\alpha = 180^\circ$
RA/ WA	5754	190	3
RB/ WB	5086	240	6
RC/ WC (2)	5083	275	6
	5383 or 5456	290	6
	5059	330	6
RD/ WD	6061, 6005A or 6082	170	6

(1) D = mandrel diameter, t = specimen thickness;
bending elongation on gauge length = 2 x width of weld (to be reported for information).

(2) The minimum tensile strength is to be reported on the approval certificate.

SECTION 3

APPROVAL OF OVER WELDABLE SHOP PRIMERS

1 Application

1.1 General

1.1.1 Shop primers applied to plates and sections to be welded are to be submitted to tests to verify their suitability for welding in respect of their tendency towards porosity in fillet welds.

1.1.2 The requirements of this Article apply to the procedure for approval and periodical control tests of over weldable shop primers.

The approval is intended to be limited to the following welding processes:

- manual metal arc welding
- automatic gravity welding
- semiautomatic bare wire or flux cored arc welding.

The acceptance of primers for use with welding processes in addition to those above will be specially considered in connection with the approval of the welding procedure at the user's works.

2 Information and documentation to be submitted

2.1 General

2.1.1 The application for the approval is to be sent to the Society by the primer Manufacturer or authorised supplier.

2.1.2 The following information and supporting documentation, as applicable, are to be submitted:

- Manufacturer
- trade name
- components of the primer, type of diluent and mixture ratio
- instructions (preparation of surfaces, method of application, drying time, recommended dry coat thicknesses, etc.)
- specified resistance to marine atmosphere
- documentation relevant to previous tests and approvals.

3 Approval tests

3.1 General

3.1.1 Approval tests are generally intended to verify the suitability of primers to obtain welds whose defects are within the usual tolerance limits.

Primer samples for approval are to be taken from a sufficiently representative quantity of primer. Sampling procedures are to be to the Surveyor's satisfaction.

Tests may be carried out at the Manufacturer's workshop, at the user's workshop or in an adequately equipped and staffed laboratory chosen in agreement with the Society.

Welding machines, welding procedures normally employed in shipyards and certified welders are to be used for the tests.

The primer is to be applied and measured on the test pieces in compliance with the Manufacturer's specification.

Thickness measurements are to be made using proper and calibrated equipment.

Thickness measurements of the primer applied to the samples, welding and fracture tests are to be performed in the presence of the Surveyor.

3.2 Base material

3.2.1 Normal strength hull steels or equivalent grades are to be used for the test specimens.

3.3 Filler metal

3.3.1 Approved filler metals are to be used.

3.3.2 Basic covered electrodes are to be used for manual metal arc welding while acid or rutile electrodes are to be used for gravity welding.

Filler metal for tests is chosen at the discretion of the Society among those usually employed in shipbuilding.

3.4 Type and dimension of test samples

3.4.1 Test samples consist of double fillet welded T-joints formed by plates of the following dimensions:

- 300mm x 120mm x 15mm for manual welding and semiautomatic bare wire and flux cored arc welding with gas shielding
- 700mm x 120mm x 15mm for automatic gravity welding.

3.5 Number of samples required

3.5.1 Different commercial brands of filler metals are to be used for the tests as follows:

- a) 4 electrodes for manual welding
- b) 1 bare wire for semiautomatic welding
- c) 2 cored wires for semiautomatic flux cored arc welding
- d) 2 electrodes for gravity welding, at least one of which is to be high efficiency.

For each brand in a), b) and c) above, two samples are required to be welded, one in horizontal position and one in vertical position, using electrodes of diameter 4 mm and wire with diameter 1,2 mm.

For each brand in d), one sample is required to be welded in horizontal position using electrodes with diameter 5 mm.

3.6 Operational procedures

3.6.1 The primer thickness (measure made on dry coat) of the test samples is to be at least 30% greater than the maximum foreseen in normal use.

The pieces are to be tack welded such as to form a T with adherent contact between the surfaces.

On one side of the T sample a fillet weld of leg size 9 mm is to be deposited.

The test fillet is to be deposited on the other side in the horizontal and vertical position as specified in [3.5] with one bead having dimensions not exceeding 7x7 mm.

Following visual examination, two auxiliary beads are to be welded along the edges of the test fillet so as to provoke fracture of its throat.

After having previously removed the first fillet, the sample is to be fractured by suitable means aiming at closing the angle of the T so as to induce a tensile stress at the root of the weld.

3.7 Test requirements

3.7.1 Visual examination is to be carried out consisting of checking the external and fractured surface to determine weld penetration and presence of worm-holes, pores and other defects.

Possible defects located within 10 mm from the ends of the weld are disregarded.

Lack of penetration having total length not exceeding 1/4 of the weld length is accepted.

Wormholes and pores having diameter not exceeding 3mm are generally acceptable where the total area of porosity is not higher than 5% of the fracture section area.

3.8 Re-tests

3.8.1 Where a maximum of two samples for each manual and semiautomatic continuous wire welding process and a maximum of one sample for the gravity welding process

give negative results, re-tests on two samples for each of those which originally failed are admitted.

Both the samples of each re-test are to provide satisfactory results. Failing this, the primer is not approved.

4 Certification

4.1

4.1.1 Subject to the satisfactory outcome of the required checks and tests, the Society will issue to the Manufacturer or supplier concerned the approval certificate for the primer authorizing its use on surfaces of rolled steel product to be welded.

5 Periodical control tests

5.1

5.1.1 The approval has three-year validity and may be renewed subject to the satisfactory outcome of the periodical tests below.

The samples required, of the T type like those for approval tests, are to be welded with at least the following filler metal:

- a) 2 electrodes for manual welding
- b) 1 bare wire for semiautomatic welding
- c) 1 cored wire for semiautomatic flux cored arc welding
- d) 1 electrode for gravity welding.

For each electrode in a) above, two samples are required to be welded, one in horizontal position and one in vertical position.

For the other materials in b), c) and d), one sample is required to be welded in horizontal position.

For sampling and test procedures, materials to be employed, test requirements and re-tests, where applicable, the provisions relevant to initial type approval apply.

Re-tests, in duplicate, are accepted only where a maximum of one sample for each welding process gives negative results.

Failing this, the approval of the primer is not confirmed.

Subject to the satisfactory outcome of the required checks and tests, a new approval certificate is issued with three-year validity.

SECTION 4

APPROVAL OF WELDING PROCEDURES

1 General

1.1 Application

1.1.1 General (1/7/2022)

This Section specifies in Articles [2], [3] and [4] the requirements for the approval of welding procedures for steel materials, and in Article [6] those for aluminium alloys.

The requirements relevant to materials not covered herein are defined on a case-by-case basis following, as far as applicable, the criteria specified in this Section.

Provisions for approval of laser welding procedures of hull structural steels are given in Sec 5.

In the case of applications involving the storage and transport of liquefied gases in bulk and the use of gases or other low-flashpoint fuels, the additional requirements in Ch 2, App 6 apply.

1.1.2 Special requirements

In the case of applications involving the storage and transport of liquefied gases, the requirements of Pt E, Ch 9, Sec 6 apply.

1.2 Welding procedure

1.2.1 Welding processes (1/1/2023)

The approval of the welding processes is, as a rule, required for the processes indicated below together with their relevant numbering according to ISO 4063:2009:

- metal arc welding with covered electrode: 111
- submerged arc welding with wire electrode: 121
- flux-cored wire metal arc welding without gas shield: 114
- metal arc inert gas welding (MIG welding): 131
- metal arc active gas welding (MAG welding): 135
- flux-cored wire metal arc welding with active gas shield: 136
- flux-cored wire metal arc welding with inert gas shield: 137
- tungsten inert gas arc welding (TIG welding): 141
- plasma arc welding: 15.

1.2.2 Welding consumables

Consumables approved in accordance with the requirements of Sec 2 are to be used within the limits of their approval.

When non-approved welding consumables are used, the requirements relevant to the qualification of the welding procedures are established on a case-by-case basis.

In any event, tests on a deposited metal sample are required.

Requirements relevant to the grade of welding consumables to be used are given in Sec 2 and, in particular for welding of hull structural steels, in Part B, Chapter 12.

1.2.3 Welding procedure specification (1/1/2015)

A welding procedure specification is to be prepared by the Manufacturer and proposed for approval; this document is also referred to as preliminary welding specification (pWPS) and may be modified and amended during the procedure tests as deemed necessary.

In its final version, the welding procedure specification (WPS) is to include all the parameters characterising the welding process (according to ISO 15614 or other recognized standard).

In particular the following parameters are to be included, as applicable:

- a) type of welding process and equipment, as appropriate
- b) type of joint, preparation and backing material, if any
- c) base metal and thickness range
- d) filler metal
- e) welding position
- f) minimum preheat and maximum interpass temperature
- g) post-weld heat treatment if applicable
- h) shielding gas as applicable
- i) welding parameters
- j) other information relevant to the welding techniques as applicable.

1.2.4 Welding procedure approval (1/1/2007)

Welding procedure tests, according to the proposed pWPS, are to be carried out for the approval of the welding procedure.

The test pieces are to be chosen so as to cover all the production welds in accordance with the approval range of parameters given in [2.7].

The tests for approval of the welding procedure (welding and testing) are to be witnessed by the Surveyor.

The actual parameters used for welding the approval test pieces and the results of the inspections and tests carried out are to be recorded in the WPQR (welding procedure qualification record).

The WPQR is generally prepared by the shipyard or welding shops and is to be signed for validation by the Surveyor.

1.2.5 Certificate of approval of the welding procedure

Upon the satisfactory completion of the approval tests, a certificate of approval of the welding procedure is generally issued by the Society to the individual users, stating the

conditions of the approval of the WPS such as thickness range, positions, steel grades and additional conditions for the application of the process, as deemed necessary, on the basis of the indications already given in the WPS.

1.2.6 Inspections

Inspections and control tests may be periodically and randomly required as deemed necessary by the Society and are to yield satisfactory results in order to maintain the validity of the approval.

The results of any suitable control performed during production may be accepted, to the Surveyor's satisfaction.

1.2.7 Responsibilities of the users

Irrespective of the inspections carried out by the Surveyor, the user is responsible for the use of the approved procedures, within the limits of the range qualified and the conditions stated at the time of the approval.

Compliance with the above is essential for the validity of the approval.

2 Welding procedures for C and C-Mn steels

2.1 Butt weld on plates

2.1.1 Assembly (1/1/2015)

Test pieces are to be of sufficient size to ensure a reasonable heat distribution during welding and to provide for the required test specimens, after sufficient discard at the ends.

The edge preparation and fit up are to be in accordance with the pWPS.

If tack welds are to be fused into the production joint, they are to be included in the test pieces.

The test assembly is to have the following minimum dimensions, in mm (see Fig 1):

- a) manual or semiautomatic welding:
 - width = $2a$, where $a = 3 \times t$, min 150 mm
 - length $b = 6 \times t$, min 350 mm
- b) automatic welding:
 - width = $2a$, where $a = 4 \times t$, min 200 mm
 - length $b = 1000$ mm.

For hull structural steel plates for which impact test is required in the longitudinal direction (CVN-L), the butt weld of the test piece is perpendicular to the rolling direction of the two plates.

2.1.2 Welding

Welding is to be carried out in accordance with the pWPS and under the general conditions of production welding which they represent.

The weld direction is to be perpendicular to the rolling direction of the plate and is to be marked on the test piece.

However, where impact tests are prescribed for the base metal in the transverse direction, the weld direction is to be parallel to the rolling direction of the plate.

2.1.3 Examinations and tests

Non-destructive examinations and destructive tests are to be in accordance with the requirements of Tab 1, while the location of the test specimens is to be in accordance with Fig 2.

2.1.4 Non-destructive examinations

Non-destructive examinations are to be carried out after any required post-weld heat treatment and prior to the cutting of test specimens.

For non-post-weld treated material susceptible to hydrogen cold cracking, the non-destructive examinations are to be delayed, as appropriate.

Imperfections are to be within the specified limits of level B in ISO 5817, except for the following imperfection types for which level C applies:

- excess weld metal or convexity,
- excess throat thickness, and
- excess of penetration.

More stringent requirements may be stipulated in the applicable parts of the Rules or in individual cases as necessary.

Figure 1 : Plate butt weld test assembly (1/1/2015)

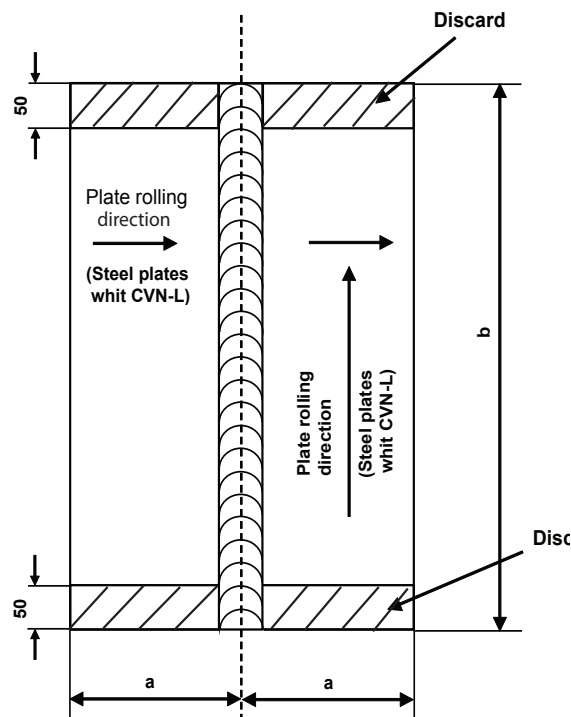
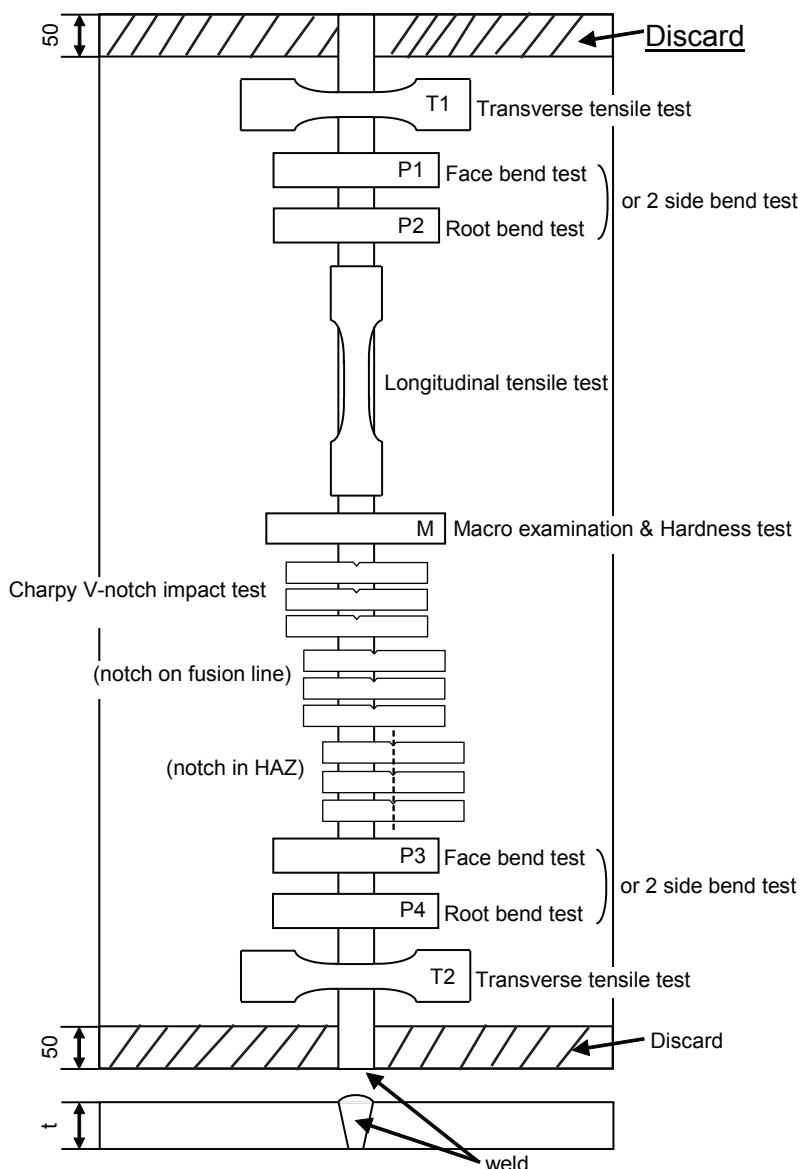

Figure 2 : Location of test specimens (1/1/2015)



2.1.5 Transverse tensile tests (1/10/2019)

Flat specimen is to be machined perpendicularly to the welded bead to the dimensions in accordance to Ch 1, Sec 2, [2.1.9].

The thickness of the test specimen is to be equal to the thickness of the parent metal near the welded joint. When the testing machine capacity does not allow testing of specimens of full thickness, multiple test specimens are to be taken to cover the full thickness of the joint and the location of the tests specimen in the welded joint thickness is to be identified.

When multiple specimens are used in lieu of full thickness specimens, each set is to represent a single tension test of the full plate thickness. Collectively, all of the specimens required to represent the full thickness of the weld at one location will comprise a set.

The tensile strength is to be not lower than the specified minimum tensile strength of the base metal; the location of the fracture is to be reported.

For joints of steels having different mechanical strength, the tensile strength is to comply with the requirement of the lower strength.

2.1.6 Tensile tests on cylindrical specimens (1/1/2007)

When required (see Tab 1), a round tensile specimen is to be cut along the weld axis to the dimension given in Ch 1, Sec 2, Fig 3, in the all weld metal.

Where the size of the deposited metal is too small, a 6 mm diameter specimen may be taken or a deposited weld metal test is to be carried out in accordance with the requirements of Sec 2.

Where more than one welding process or type of consumable has been used to make the test weld, test specimens are to be taken from the area of the weld where

each was used with the exception of those processes or consumables used to make the first weld run or root deposit.

The results of the test (yield stress R_{eH} , tensile strength R_m and elongation A_5) are to be determined and to comply with the requirements given for the approval of consumables.

Table 1 : Examinations and tests (1/1/2015)

Type of examination or test	Extent of examination or test
Visual examination	100%
Radiographic or ultrasonic examination	100%
Surface crack detection (1)	100%
Transverse tensile test	2 specimens
Transverse bend tests (2)	2 root and 2 face specimens
Impact tests (3)	3 sets
Macro examination	1 section
Hardness test (4)	on 1 section
Longitudinal tensile test (5)	1 specimen
<p>(1) Dye penetrant according to ISO 3452 (or equivalent accepted standard) or magnetic particle testing; for non-magnetic materials, dye penetrant only.</p> <p>(2) For $t \geq 12\text{mm}$, the face and root bends are preferably to be replaced by 4 side bends.</p> <p>(3) 3 sets each of 3 specimens as per [2.1.8].</p> <p>(4) Only required for high strength steels.</p> <p>(5) Required only when the use of non-approved filler metal has been accepted (see [1.2.2]).</p>	

2.1.7 Bend tests (1/10/2019)

Transverse root bend, face bend and side bend specimens are to be machined to the dimensions given in Ch 1, Sec 2, [3].

Face and root bend test specimens having 30 mm width and full plate thickness are to be machined transverse to the welded joint. The upper and lower surfaces of the weld are to be filed, ground or machined flush with the surface of the

plate and the corners in tension rounded to a radius not exceeding 2 mm.

For dissimilar or heterogeneous butt-joints, one longitudinal bend test may be used instead of transverse bend tests.

The test specimens are to be bent on a mandrel having a diameter 4 times the thickness of the specimen; the bending angle is to be 180°.

During the testing, the test specimens are not to reveal any open defect, in any direction, greater than 3 mm. Defects appearing at the corner of the test specimen may be disregarded.

2.1.8 Impact tests (1/1/2015)

Charpy V-notch impact test specimens are to be taken from 1 to 2 mm below the surface of the sample (on the side containing the last run) and machined to the dimensions indicated in Ch 1, Sec 2.

Three sets of Charpy V-notch specimens (each set including 3 specimens) are to be taken as indicated in Fig 3 and Fig 4.

Test temperature and absorbed energy are to be in accordance with Table 2.

Only one individual value may be lower than the average required, provided it is not lower than 70% of it.

with the requirements of the lower steel grade.

When butt welds are made between different steel grades/types, the test specimens are to be taken from the side of the joint with lower toughness of steel. Temperature and absorbed energy results are to be in accordance with the requirements for the lower toughness steel.

Unless otherwise required, the test temperature and absorbed energy of steels not covered by these requirements are to be in accordance with the specification of the parent metal.

Where more than one welding process or consumable has been used to make the test weld, impact test specimens are to be taken from the respective areas where each was employed. This is not to apply to the process or consumables used solely to make the first weld run or root deposit.

Requirements for reduced Charpy V specimens are given in Ch 1, Sec 2, [4.2.2].

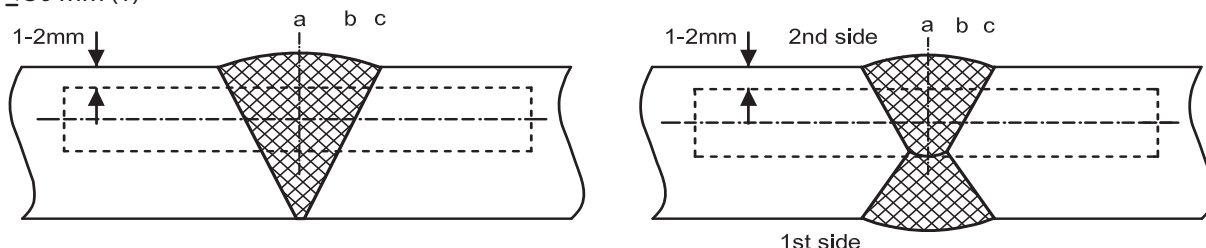
Figure 3 : Locations of V-notch for butt weld of normal heat input (heat input ≤ 50 kJ/cm) (1/1/2007)a) $t \leq 50$ mm (1)

Note (1) : For one side single run welding over 20mm notch location "a" is to be added on rootside.

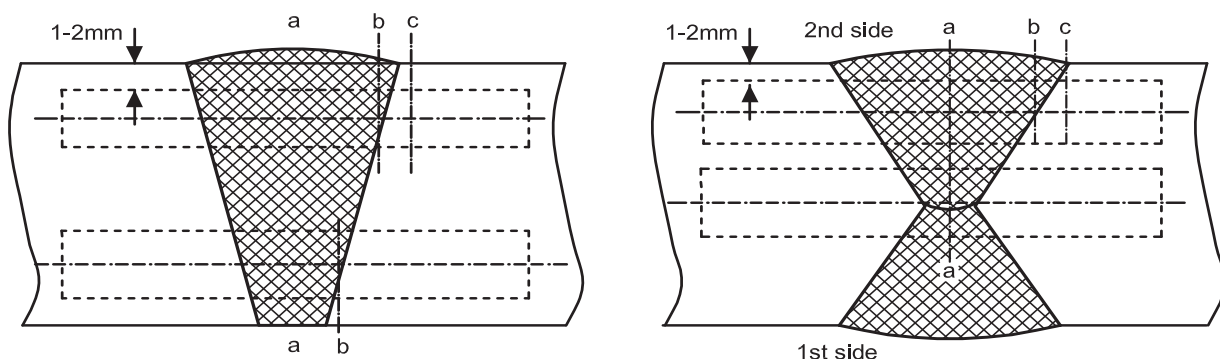
b) $t > 50$ mm

Notch locations:

- a: centre of weld "WM"
- b: on fusion line "FL"
- c: in HAZ, 2 mm from fusion line

2.1.9 Macro examinations (1/1/2015)

The test specimens are to be prepared and etched on one side to clearly reveal the fusion line, the HAZ, the build up of the runs and the unaffected parent metal.

The acceptance levels are given in [2.1.4].

Macro examination is to include about 10 mm unaffected base metal.

The examination is to reveal a regular weld profile, through fusion between adjacent layers of weld and base metal and the absence of defects such as cracks, lack of fusion etc.

2.1.10 Hardness tests (1/1/2015)

The hardness measurements are to be carried out on the macro section; normally the Vickers method HV10 is to be used.

The indentations are to be made in the weld, heat affected zones, and the parent metal with the object of measuring and recording the range of values in the weld joint. This will include rows of indentations, one of which is to be 2mm maximum below the surface.

For each row of indentations, a minimum of 3 individual indentations is required in the weld, both sides of the HAZ and the parent metal.

For the HAZ, the first indentation is to be placed as close as possible to the fusion line.

The distance between the indentations may vary from 1 to 2 mm depending on the zone tested.

The recommended distance between indentations for hardness test in the heat affected zone is 1 mm, provided this is not less than the value allowed by ISO 6507/1.

Typical example of hardness indentations are given in Fig 5.

The results of hardness tests are, as a rule, not to exceed 350 HV.

Table 2 : Impact test requirements for butt joints ($t \leq 50$ mm) (1) (2) (1/1/2015)

Grade of steel	Test temperature (°C)	Value of minimum average absorbed energy (J)		
		For manually or semi-automatically welded joints		For automatically welded joints
		Downhand, Horizontal, Overhead	Vertical upward, Vertical downward	
A (3)	20	47	34	34
B (3), D	0			
E	- 20			
A32, A36	20			
D32, D36	0			
E32, E36	- 20			
F32, F36	- 40	39	39	39
A40	20			
D40	0			
E40	- 20			
F40	- 40			

- (1) For thickness above 50 mm, impact test requirements are to be agreed by the Society.
- (2) These requirements are to apply to test pieces where the butt weld is perpendicular to the rolling direction of the plates.
- (3) For Grade A and B steels, average absorbed energy on the fusion line and in the heat-affected zone is to be minimum 27 J.

Figure 4 : Locations of V-notch for butt weld of high heat input (heat input > 50kJ/cm) (1/1/2015)

a) $t \leq 50$ mm (1)

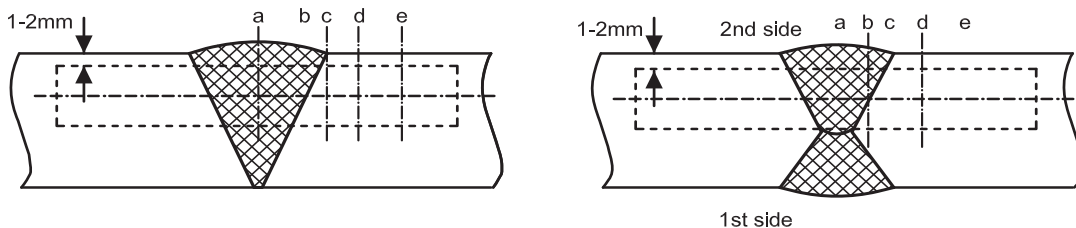

Note (1): For one side welding with thickness over 20 mm notch locations "a," "b" and "c" are to be added on root side.

b) $t > 50$ mm

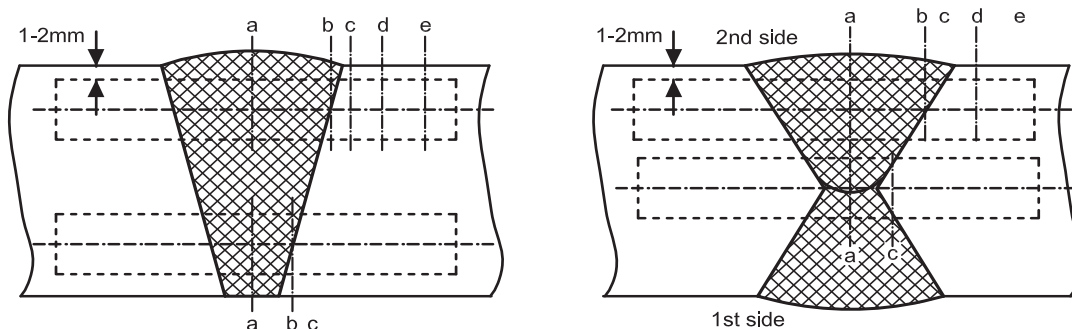

input > 200kJ/cm

Notch locations:

- a: centre of weld "WM"
- b: on fusion line "FL"
- c: in HAZ, 2 mm from fusion line
- d: in HAZ, 5 mm from fusion line
- e: in HAZ, 10 mm from fusion line in case of heat

Figure 5 : Examples of hardness indentations (1/1/2007)

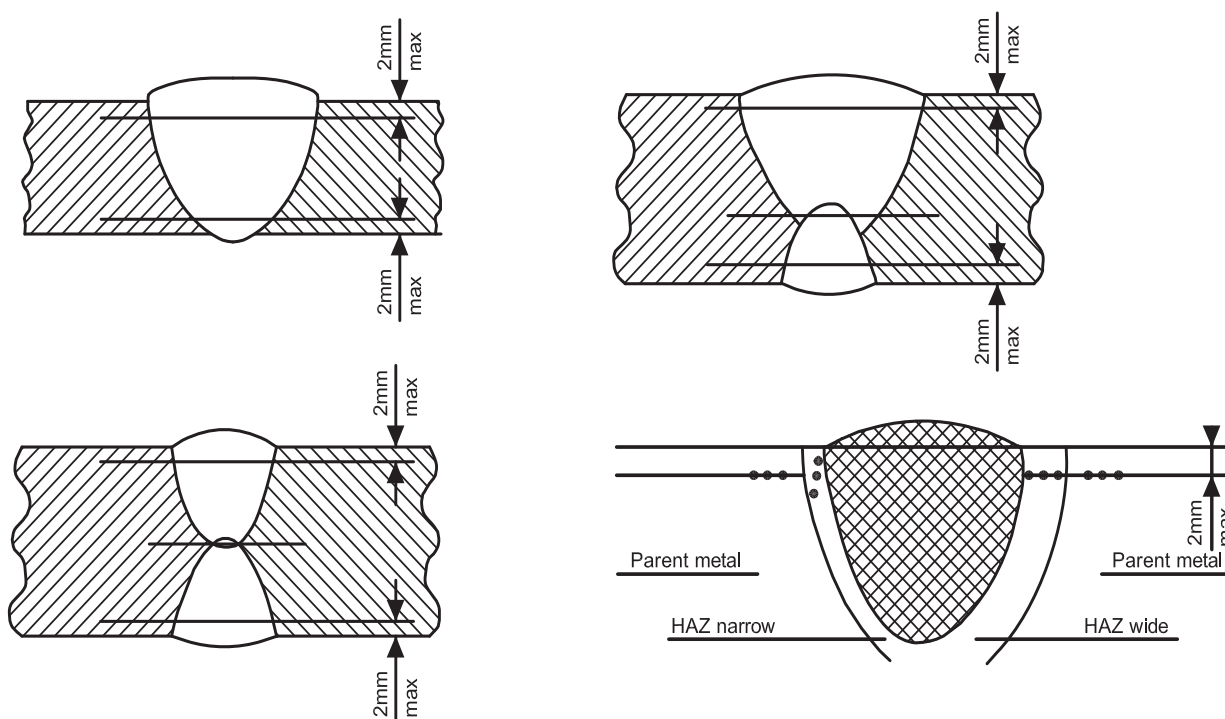

2.2 T butt-joint on plates

2.2.1 Assembly and welding

The test assembly is to be in accordance with Fig 6.

The edge preparation, fit-up and welding are to be in accordance with the pWPS.

If tack welds are to be fused into the production joint, they are to be included in the test piece.

The dimensions of the test piece are to be such as to provide for the tests in Tab 3; the minimum size of the assembly is to be:

W = 350 mm; L = 350 mm.

Figure 6 : T butt joint on plates

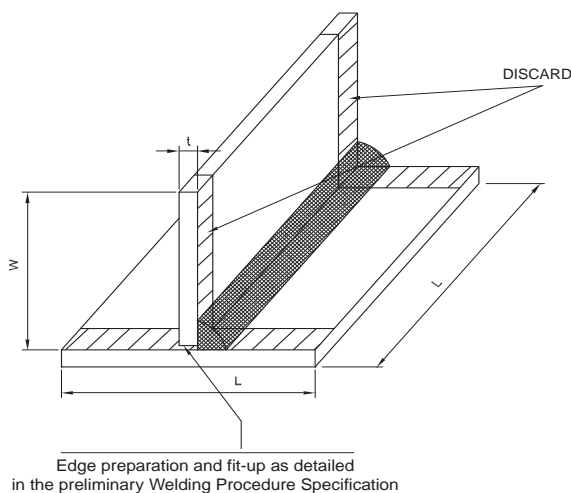

2.2.2 Examinations and tests

Non-destructive examinations and destructive tests are to be in accordance with the requirements of Tab 3; a discard of 50mm from both edges is permitted.

Additional tests for the verification of the mechanical properties of the joint should be considered when not covered by other WPS.

Table 3 : Examination and tests

Type of examination or test	Extent of examination or test
Visual examination	100%
Surface crack detection (1)	100%
Ultrasonic (2)	100%
Macro examination	2 sections
Hardness test (3)	on 1section
(1) Dye penetrant according to ISO 3452 (or equivalent accepted standard) or magnetic particle testing; for non-magnetic materials, dye penetrant only.	
(2) Only applicable for $t \geq 12\text{mm}$	
(3) Only required for high strength steels	

2.2.3 Visual examination and surface crack detection

The requirements specified in [2.1.4] are to be complied with.

Figure 7 : Examples of hardness indentations (1/1/2015)

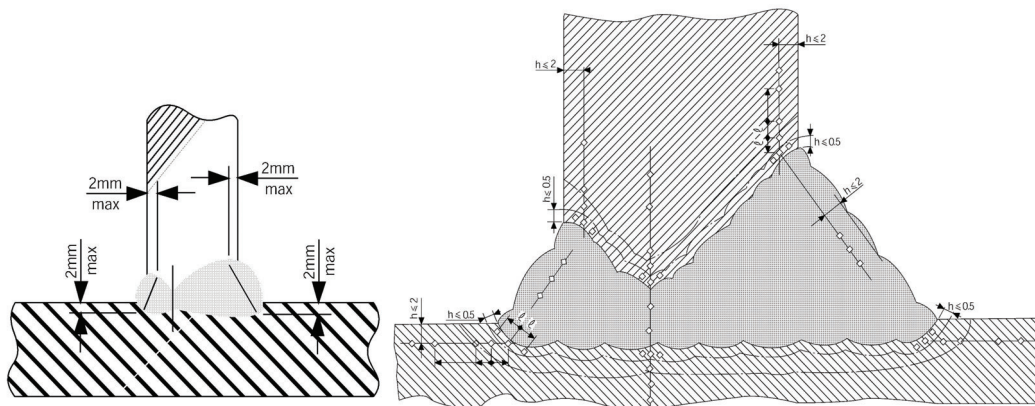

2.2.4 Macro examinations and hardness tests

The requirements specified in [2.1.9] and [2.1.10] are to be complied with as appropriate.

Typical examples of hardness indentations are given in Fig 7.

2.3 T fillet joint

2.3.1 Assembly and welding (1/1/2015)

The minimum size of test assembly is to be as follows (see Fig 8):

- a) manual or semiautomatic welding:
 - width $a = 3 \times t$, min 150 mm
 - length $b = 6 \times t$, min 350 mm
- b) automatic welding:

width $a = 3 \times t$, min 150 mm

length $b = 1000$ mm

The two plates are to be positioned and tack welded edgewise so as to constitute a T assembly without clearance.

The test assembly is to be welded on one side only, except for the case specified below.

Test assembly is to be welded on both sides in case of automatic welding processes, when using equipment intended for both sides welding, according to the relevant pWPS.

For manual and semiautomatic welding, a stop/restart position is to be included in the first run and is to be clearly marked for subsequent examination.

Figure 8 : T fillet joint on plate (1/1/2015)

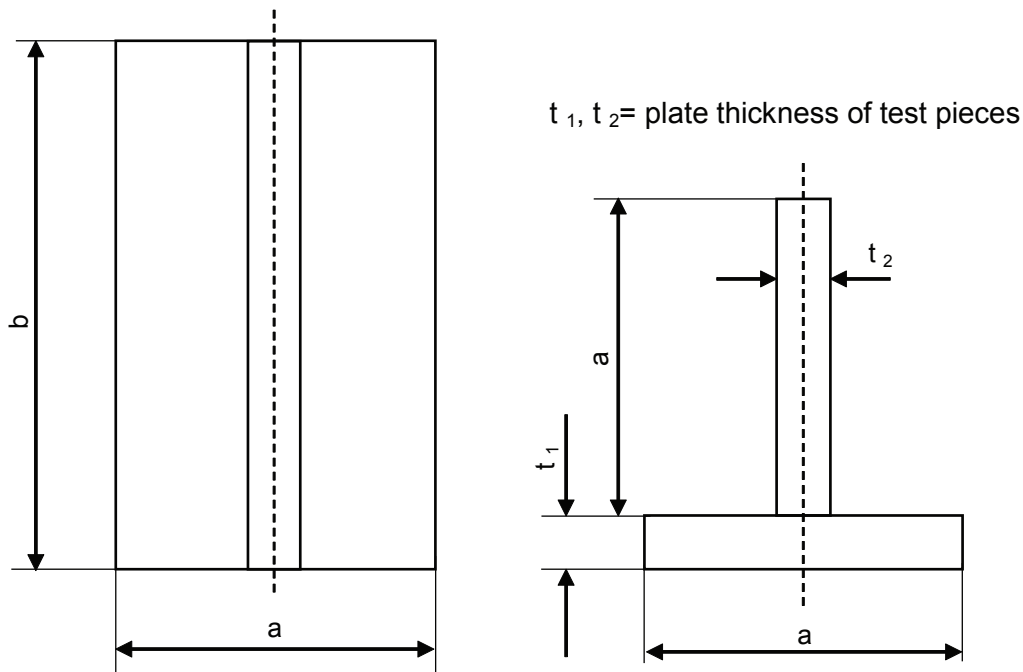

2.3.2 Examinations and tests

Non-destructive examinations and destructive tests are to be in accordance with the requirements of Tab 4; a discard of 50 mm from both edges is permitted.

Table 4 : Examinations and tests (1/1/2007)

Type of examination or test	Extent of examination or test
Visual examination	100%
Surface crack detection (1)	100%
Macro examination (2)	2 sections
Hardness test (3)	on 1 section
Fracture test	100%
(1) Dye penetrant according to ISO 3452 (or equivalent accepted standard) or magnetic particle testing; for non-magnetic materials, dye penetrant only. (2) One of the macro sections is to be taken at the position of the stop/restart; see [2.3.1]. (3) Only required for high strength steels	

2.3.3 Visual examination and surface crack detection

The requirements specified in [2.1.4] are to be complied with.

2.3.4 Macro examinations and fracture tests (1/1/2015)

The requirements specified in [2.1.9] are to be complied with as appropriate.

The fracture of the sample is to be obtained by suitable means aimed at closing the angle of the Tee where the fillet weld has been deposited, so as to induce a tensile stress at the root of the fillet.

Evaluation is to concentrate on cracks, porosity and pores, inclusions, lack of fusion and incomplete penetration. Imperfection that are detected is to be assessed in accordance with ISO 5817, class B.

The result of the fracture test as well of the macro examination is to show the absence of defects, in particular lack of root penetration; when the reduction of the weld size, in association with the specific welding process, is required (see Pt B, Ch 12, Sec 1), the tests and examinations are to prove that the root penetration is not less than the applicable required value.

The dimensions of leg size, throat and penetration are to be reported. The penetration is measured by the distance 'x' in the bisector plane as indicated in Fig 9.

2.3.5 Hardness test

The indentations are to be in accordance with Fig 9 and the requirements specified in [2.1.10] are to be complied with, as appropriate.

Figure 9 : Macro and hardness indentations (1/1/2015)

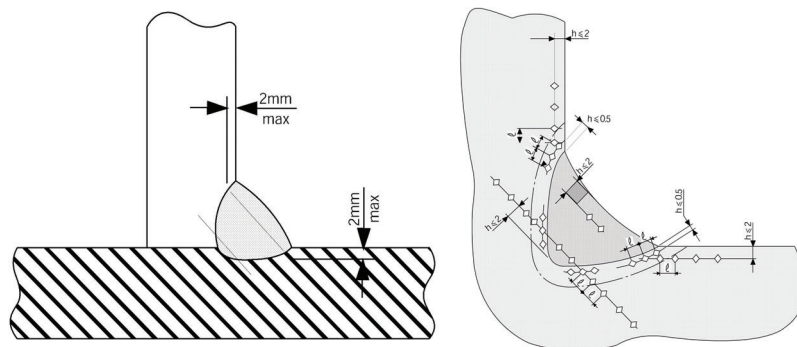

2.4 Butt weld on pipes

2.4.1 Assembly and welding

The test assembly is to be in accordance with Fig 10.

The edge preparation and fit-up are to be in accordance with the pWPS. The pipe diameter is to be sufficient to obtain the required specimens or, in the case of small pipe diameters, several test pieces may be necessary.

Figure 10 : Pipe weld test assembly

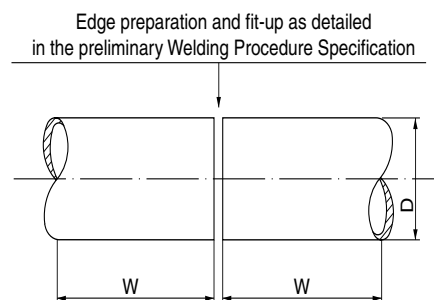

W : minimum value = 150 mm; D = outside diameter

Figure 11 : Location of the test specimens

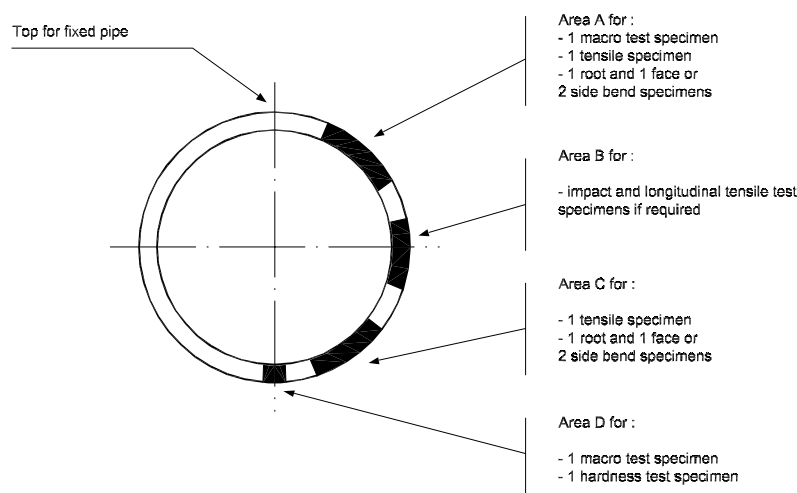

2.4.2 Examinations and tests

Non-destructive examinations and destructive tests are to be in accordance with the requirements of Tab 1, while the location of the test specimens is to be in accordance with Fig 11.

2.4.3 Results

The results are to comply with the requirements for butt tests on plates in [2.1].

2.5 Re-testing

2.5.1 If the qualification assembly fails to comply with any of the requirements for visual examination or NDE, one extra assembly is to be welded and subjected to the same examination.

If this additional assembly does not comply with the relevant requirements, the welding process is not approved and the pWPS is to be modified before further consideration is given to a new test assembly for qualification.

2.5.2 (1/1/2015)

When a destructive test (other than Charpy V for which the requirements in Sec 2, [3.3.2] apply) does not meet the requirements due to geometric welding imperfections of the specimens, two additional specimens are to be obtained for each one that failed. These tests may be taken from the same assembly if there is sufficient material, or from a new qualification test to be welded using the same procedure. For acceptance, both tests are to give satisfactory results.

2.5.3 (1/1/2007)

If there is a single hardness value above the maximum values allowed, additional hardness tests are to be carried out (on the reverse of the specimen or after sufficient grinding of the tested surface). None of the additional hardness values is to exceed the maximum hardness values required.

2.6 Test record

2.6.1 General (1/1/2015)

Welding conditions for test assemblies and test results are to be recorded in welding procedure test record.

A statement of the results of assessing each test piece, including repeat tests, is to be made for each welding procedure test. The relevant items listed for the WPS of these requirements are to be included.

A statement that the test piece was made according to the particular welding procedure is to be signed by the Surveyor witnessing the test.

2.7 Range of approval

2.7.1 General (1/1/2007)

The approval of a WPS obtained by a yard or Manufacturer is valid for all its workshops under the same technical and quality control, to the Society's satisfaction.

Due to the influence of shop primers on quality of fillet welds, welding procedure qualification with shop primer will qualify those without but not vice versa.

The welding procedure is to be used within the range of the parameters indicated below; changes outside the range specified of one or more of these parameters require a new welding procedure test.

2.7.2 Parent metal (1/1/2007)

For each strength level, welding procedures are considered applicable to the same toughness grade as that tested and lower grades.

For each toughness grade, welding procedures are considered applicable to the same strength level as that tested and two lower strength levels.

For high heat input processes above 50kJ/cm, e.g. the two-run technique with either submerged arc or gas shielded metal arc welding, electro slag and electro gas welding, the

welding procedure is applicable to that toughness grade tested and one strength level below.

Where steels used for construction are supplied in different delivery conditions from those tested, the Society may require additional tests.

2.7.3 Thickness (1/1/2007)

The qualification of a WPS carried out on a test assembly of thickness t is valid for the thickness range given in Tab 5.

In addition to the requirements of Tab 5, the range of approval of throat thickness "a" for fillet welds is to be as follows:

- Single run ; "0,75 a" to "1,5 a"
- Multi-run ; as for butt welds with multi-run (i.e. $a=t$)

For the vertical-down welding, the test piece thickness "t" is always taken as the upper limit of the range of application.

For unequal plate thickness of butt welds, the lesser thickness is ruling dimension.

Notwithstanding the above, the approval of maximum thickness of base metal for any technique is to be restricted to the thickness of the test assembly if three of the hardness values in the heat-affected zone are found to be within 25 HV of the maximum permitted, as stated in [2.1.10].

2.7.4 Pipe diameter

Approval of a WPS carried out on a pipe of diameter D is valid for diameters in the range given in Tab 6.

2.7.5 Welding position

Unless otherwise specified on a case-by-case basis, qualification obtained for one position is extended to all the welding positions, provided that neither impact tests nor hardness tests are required.

When impact and/or hardness requirements are specified, impact tests and hardness tests are to be performed from the highest and the lowest heat input position, respectively, in order to obtain qualification for all positions.

2.7.6 Type of joint

The range of approval of the type of joints is given in Tab 7.

A new approval may also be required by the Surveyor when changes occur in the geometry of the bevel which significantly affect the penetration or fusion.

Table 5 : Approved thickness range (1/1/2007)

Thickness t of the test piece (mm) (1)	Range of approval	
	Single run or single run from both sides of butt welds and T butt-joints	Multi-run welding of butt and T butt welds and all fillet welds (2)
$t \leq 12$	0,7 t to 1,1 t	3mm to 2 t (4)
$12 < t \leq 100$	0,7 t to 1,1 t (3)	0,5 t to 2 t (max.150mm)

(1) For multi-process procedures, the recorded thickness contribution of each process is to be used as a basis for the range of approval for the individual welding process.

(2) For fillet welds, the range of approval is to be applied to both base metals.

(3) For high heat input processes over 50kJ/cm, the upper limit of range of approval is to be 1,0 t .

(4) For thickness of the test piece less than 3 mm, the minimum thickness approved is the thickness welded.

Table 6 : Approved diameter range

Diameter of the test piece (mm)	Range of approval (1)
$D < 168,3$	0,5 D to 2 D
$D \geq 168,3$	$\geq 0,5 D$ and plates

(1) Qualification given for plates also covers pipes with outside diameter > 500 mm.

Table 7 : Range of approval for type of joint (1/1/2013)

Type of joint in the approval test piece			Range of approval						
			Butt welds on plate				T butt joints on plate		Fillet welds on plate and pipe
			Welded from one side		Welded from bothsides		Welded from one side	Welded from both sides	
With backing	No backing	With gouging	No gouging						
Butt weld on plate	One side (1)	With backing	◊	-	x	-	x (2)	x	x
		No backing	x	◊	x	x	x	x	x
	Both sides	With gouging	-	-	◊	-	-	x	x
		No gouging	-	-	x	◊	-	x	x

Note 1:
 ◊ indicates the type of assembly which is qualified in the approval test.
 x indicates those welds for which the WPS is also approved.
 - indicates those welds for which the WPS is not approved.

(1) Butt welds on a plate welded from one side approve butt welds on pipes having diameter > 500 mm within the limitations of the table.
 (2) with backing

Type of joint in the approval test piece		Range of approval						
		Butt welds on plate				T butt joints on plate		Fillet welds on plate and pipe
		Welded from one side		Welded from bothsides		Welded from one side	Welded from both sides	
		With backing	No backing	With gouging	No gouging			
T butt weld on plate	One side	-	-	-	-	◇	x	x
	Both sides	-	-	-	-	-	◇	x
Fillet weld	Plate	-	-	--	-	-	-	◇

Note 1:
 ◇ indicates the type of assembly which is qualified in the approval test.
 x indicates those welds for which the WPS is also approved.
 - indicates those welds for which the WPS is not approved.
 (1) Butt welds on a plate welded from one side approve butt welds on pipes having diameter > 500mm within the limitations of the table.
 (2) with backing

2.7.7 Welding process (1/1/2007)

Changes in the welding process and/or type of current (a.c., d.c., pulsed) require a new welding procedure approval.

It is not permitted to change from a multi-run to a single run. For multi-process procedures the welding procedure approval may be carried out with separate welding procedure tests for each welding process. It is also possible to conduct the welding procedure test as a multi-process procedure test. The approval of such a test is only valid for the process sequence carried out during the multi-process procedure test.

2.7.8 Welding consumables (1/1/2007)

Changes in the type and/or trade name of filler metal require a new welding procedure approval.

Reduction of applicable tests may be considered in the case of 111, 141, 131 and 135 processes.

2.7.9 Submerged arc welding (12)

In the submerged arc process, the approval obtained is restricted to the wire system used in the approval test (e.g. single wire or multi-wire) and relevant welding technique (T, M, U).

2.7.10 Gas metal arc welding (131, 135, 136)

The approval obtained for face and/or back shielding gas is restricted to the type of gas (nominal composition) used during the procedure test.

The approval is restricted to the wire system used in the approval test (e.g. single wire or multi-wire) and, in the case of automatic welding, to the relevant welding technique.

2.7.11 Manual metal arc welding (111) and semiautomatic welding process with flux cored wire without gas shield (114)

The approval obtained is valid for the diameter of the electrode used in the welding procedure test plus or minus one electrode diameter size for each run, except for the root run of the one side welded assembly without backing strip, for which no size change is allowed.

2.7.12 Heat input (1/1/2007)

When impact requirements apply, the upper limit of heat input qualified is 25% greater than that used during the welding procedure test or 55kJ/cm, whichever is the lesser, except that the upper limit is 10% greater than that for high heat input processes over 50kJ/cm.

When hardness requirements apply, the lower limit of heat input qualified is 25% lower than that used during the welding procedure test.

2.7.13 Preheat and interpass temperature

The lower limit of approval is the nominal preheat at the start of the welding procedure test.

The upper limit of approval is the nominal interpass temperature reached in the welding procedure test.

2.7.14 Post-weld heat treatment (1/1/2007)

The addition or deletion of a post-weld heat treatment requires a new welding procedure approval.

Holding time may be adjusted as a function of thickness.

3 Welding procedures for Cr-Ni austenitic and austenitic-ferritic stainless steels for application with chemicals

3.1 General

3.1.1 Test pieces, tests and requirements for the approval of the welding procedures are stated on a case-by-case basis, according to criteria analogous to those specified in [2.1] to [2.7].

3.1.2 Checks of the chemical composition of the welded zone may be required and, in the case of austenitic-ferritic steels, the examination of the metallographic structure for the determination of the ferrite content is generally to be performed (value required according to ASTM E 562: 25-70%).

Impact tests are not required in the case of austenitic steels and are to be performed at -20°C in the case of austenitic-

ferritic steels; the average value for the absorber energy is to be not lower than 27 J.

Corrosion tests according to recognised standards may be required depending on the type of steel.

3.1.3 Indications relevant to the approval class of consumables and parent metal which can be welded are given in Tab 8.

Table 8 : Selection of consumable approval grades suitable for welding Cr-Ni austenitic steels

Consumable approval grade	Steels which can be welded
308	304
308L	304 - 304L
316	304 - 316
316L	304 - 304L - 316 - 316L
316LN	304 - 304L - 316 - 316L - 316LN - 316Ti - 316Nb
317	304 - 316 - 317
317L	304 - 304L - 316 - 316L - 317 - 317L
309	309 (1)
309L	309 - 309L (1)
309 Mo	309 - 309Mo - 316 (1)
310	310 (1)
310Mo	310 - 310Mo (1)
347	321 - 347
(1) Also heterogeneous joints between ferritic and austenitic steels	

4 Approval of welding procedures for high strength quenched and tempered steels

4.1 General

4.1.1 (1/1/2015)

Test pieces, tests and requirements for the approval of the welding procedures are to be carried out according to same criteria as those specified in [2.1] to [2.7], unless as specified in this Article.

For high strength quenched and tempered steel plates for which impact test is required in the transverse direction (CVN-T), the butt weld of the test piece is parallel to the rolling direction of the two plates.

4.1.2 (1/1/2015)

The bend specimens are to be bent on a mandrel having diameter 5 times the specimen thickness in the case of steel types B420, B460 and B500, and 6 times the specimen thickness in the case of steel types B550, B620 and B690.

The Vickers hardness values HV10 are to be not higher than 420 HV.

4.1.3 Mechanical tests on all weld metal may be required on a case-by-case basis.

4.1.4 The approval of the procedures is generally restricted to the individual specification of the steel used in the approval tests.

4.1.5 (1/1/2015)

For high strength quenched and tempered steel with specified minimum yield strength of 420 N/mm² and above the non-destructive testing is to be delayed for a minimum of 48 hrs, unless heat treatment has been carried out.

4.1.6 Impact test (1/1/2015)

The requirements specified in [2.1.8] are to be complied with as appropriate.

Test temperature and absorbed energy are to be in accordance with the requirements of parent metal.

5 Approval of welding procedures for forgings and castings

5.1 General

5.1.1 (1/1/2007)

Test pieces, tests and requirements for the approval of the welding procedures are stated on a case-by-case basis, according to criteria similar to those specified in [2.1] to [2.7], unless otherwise specified in this Article.

5.1.2 (1/1/2007)

For base metal with specified impact values, test temperature and absorbed energy are to be in accordance with the requirements of the base metal to be welded.

5.1.3 (1/1/2007)

Welding procedures are considered applicable to the same strength level as that tested and to lower strength levels.

5.1.4 (1/1/2007)

The approval of quenched and tempered hull steel products does not qualify other delivery conditions and vice versa.

6 Approval of welding procedures for aluminium alloys

6.1 Butt weld on plates

6.1.1 Assembly and welding

The requirements of [2.1.1] and [2.1.2] apply.

The cleaning of the parts to be welded is to be carried out with appropriate procedures which are then to be followed in the construction.

Welding consumables are to be approved by the Society in accordance with Sec 2, [14].

6.1.2 Examinations and tests

Non-destructive examinations and destructive tests are to be in accordance with the requirements of Tab 9, while the location of the test specimens is to be in accordance with Fig 2.

Table 9 : Examinations and tests

Type of examination or test	Extent of examination or test
Visual examination	100%
Radiographic or ultrasonic examination	100%
Dye penetrant test	100%
Transverse tensile tests	2 specimens
Transverse bend tests (1)	2 root and 2 face specimens
Macro examination	1 section
Check of Mg content (2)	weld metal

(1) The face and root bends are preferably to be replaced by 4 side bends for $t \geq 12$ mm.
 (2) In the case of non-approved filler metal, the check of Mg content and other checks, as appropriate, are generally required.

6.1.3 Non-destructive examinations

Non-destructive examinations are to be carried out after any required post-weld heat treatment and natural or artificial aging, and prior to the cutting of test specimens.

Welds are to be reasonably free from defects. In particular, cracks are not allowed; inclusion of oxides may be permitted where of limited extent and widely scattered (single porosity having diameter between 0,5 and 1,5 mm may be accepted as well as short lengths of weld with in-line porosity or small $\leq 0,5$ mm scattered porosity).

For the evaluation of the results of the radiographic examination, it should be borne in mind that in-line porosity is frequently associated with widespread inclusions of oxides; in such cases it may be advisable to require fracture test specimens obtained in the way of the in-line porosities.

Defects are to be within the specified limits of level B in ISO/DIS10042.2, except for the following imperfection types, for which level C applies: excess weld metal or convexity, excess throat thickness and excess penetration.

More stringent requirements may be stipulated in the applicable parts of the Rules or required on a case-by-case basis.

6.1.4 Transverse tensile tests

Specimens for transverse tensile tests are to be in accordance with Fig 12.

The weld is to be made flush maintaining the thickness of the assembly.

Figure 12 : Transverse tensile specimen

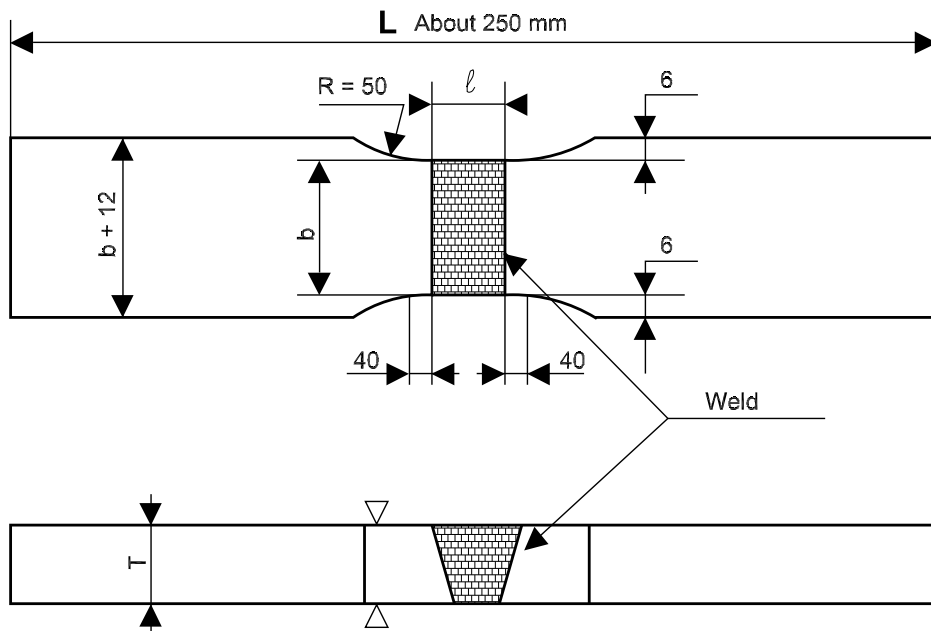

l = widest part of the weld line
 $b = 38 \pm 0,25$ mm, if $t \leq 25$ mm
 $b = 25 \pm 0,25$ mm, if $t > 25$ mm.

Table 10 : Specified mechanical properties for series 6000 extruded products

Alloy	Temper	Yield strength $R_{p0.2}$ min. (N/mm ²)	Tensile strength R_m min. (N/mm ²)	Tensile strength after welding R_m min. (N/mm ²)
6005 A	T5, T6	215	260	150
6005 A (closed sections)	T5, T6	215	250	150
6061	T4, T5, T6	240	260	150
6061 (closed sections)	T4, T5, T6	205	245	150
6082 (sections)	T4, T5, T6	260	310	165
6082 (closed sections)	T4, T5, T6	240	290	165

For series 5000 alloys, the tensile strength of the test specimen is to be not lower than the specified minimum tensile strength of the parent metal in the soft condition: 0 or H111 (see Ch 3, Sec 2).

For series 6000 alloys, the tensile strength of the test specimen is to be not lower than the specified minimum value of the parent metal after welding given in Tab 10.

6.1.5 Bend tests (1/10/2019)

Transverse root bend, face bend and side bend specimens are to be machined to the dimensions given in Ch 1, Sec 2, [3].

Face and root bend test specimens having 30 mm width and full plate thickness are to be machined transverse to the welded joint. The upper and lower surfaces of the weld are to be filed, ground or machined flush with the surface of the plate and the corners in tension rounded to a radius not exceeding 2 mm.

For dissimilar or heterogeneous butt joints, one longitudinal bend test may be used instead of transverse bend tests.

The test is to be carried out on a mandrel having diameter $6t$ for series 5000 alloys (except alloy 5754) or $7t$ for series 6000 alloys, t being the thickness of the specimen; for alloy 5754, the mandrel diameter is to be $4t$. The bending angle is to be 180° .

The "wrap around bending method" is the recommended bending procedure in lieu of the usual "free" bend test (see Fig 13).

During the testing, the test specimens are not to reveal any open defect, in any direction, greater than 3 mm. Defects appearing at the corner of the test specimen are disregarded.

6.1.6 Macro examination

The test specimens are to be prepared and etched on one side to clearly reveal the fusion line, the HAZ, the build up of the runs and the unaffected parent metal. The examination is to reveal a regular weld profile, thorough fusion between adjacent layers of weld and base metal, and the absence of defects such as cracks and lack of fusion.

The acceptance levels of other imperfections are given in [6.1.3].

6.2 T fillet joint

6.2.1 Assembly and welding

The requirements of [2.3.1] apply.

The plate thickness is to be close to the average value of proposed range of thickness; the throat thickness of the weld is to be appropriate to the thickness of the web of the T.

The cleaning of the parts to be welded is to be carried out with the same procedure to be used in the construction.

6.2.2 Examinations and tests

Non-destructive examinations and destructive tests are to be in accordance with the requirements of Tab 11; a discard of 50 mm from both edges is allowed.

Table 11 : Examinations and tests

Type of examination or test	Extent of examination or test
Visual examination	100%
Dye penetrant test	100%
Macro examination (1)	2 specimens
Fracture test	2 specimens
(1) One of the macro sections is to be taken at the position of the stop/restart (see [2.3.1]).	

6.2.3 Visual examination and surface crack detection

The requirements specified in [6.1.3] are to be complied with.

6.2.4 Macro examination and fracture test

The result of the fracture test as well as the macro examination are to show the absence of defects, in particular lack of root penetration.

Defects such as blowholes or inclusions are not to exceed 6% of the fracture section examined.

The dimensions of leg size, throat and penetration are generally to be reported.

6.3 Range of approval

6.3.1 General

Unless otherwise specified in this Article, reference may be made to the requirements in [2.7].

6.3.2 Parent metal

A welding procedure test is generally required for each grade of aluminium alloy.

6.3.3 Welding positions

The test pieces are to be welded in the most unfavourable of the welding positions used in construction (vertical and overhead positions, as applicable).

Figure 13 : Wrap around bend test

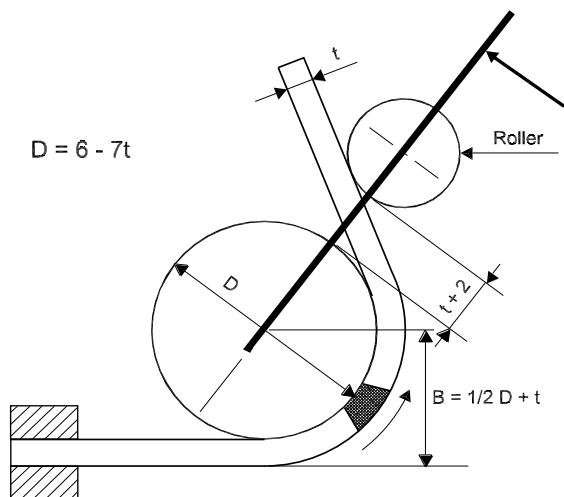

The fixed edge of the test specimen is to be clamped to avoid sliding. The whole welded zone (weld and heat affected zone), in the case of transverse bending, is to be entirely positioned in the bent zone.

7 Approval of welding procedure qualification tests for repair of propellers

7.1 General

7.1.1 (1/7/2021)

The provisions of this Article apply to the approval of welding procedure qualification tests to be used for repair by welding of cast copper alloy or cast steel propellers or propeller blades, as applicable.

7.1.2 (1/7/2021)

The welding of the procedure qualification test sample is to be carried out in accordance with the pWPS prepared by the company wishing to carry out welding work and under the general conditions of production welding which they represent.

For the welding procedure approval the welding procedure qualification tests are to be carried out with satisfactory results. The qualification tests are to be carried out with the same welding process, filler metal, preheating and stress-relieving treatment as those intended applied by the actual repair work. WPS is to refer to the test results achieved during welding procedure qualification testing.

Welding procedures qualified at a manufacturer are valid for welding in workshops under the same technical and quality management.

7.2 Test piece and welding of sample

7.2.1 (1/7/2021)

For cast copper alloy propellers a butt weld test sample of minimum 30mm thickness is to be welded in the flat position. The test assembly, consisting of cast samples, is to be of a size sufficient to ensure a reasonable heat distribution and according to Fig 14 and Fig 15 for cast copper alloy propellers and cast steel propellers, respectively.

Figure 14 : Test piece for welding repair procedure for cast copper alloy propellers (1/7/2021)

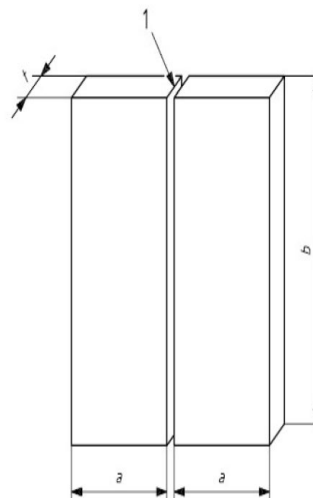

- 1: Joint preparation and fit-up as detailed in the preliminary welding procedure specification
- a: minimum value 150mm
- b: minimum value 300mm
- t: material thickness.

Figure 15 : Test piece for welding repair procedure for cast steel propellers (1/7/2021)

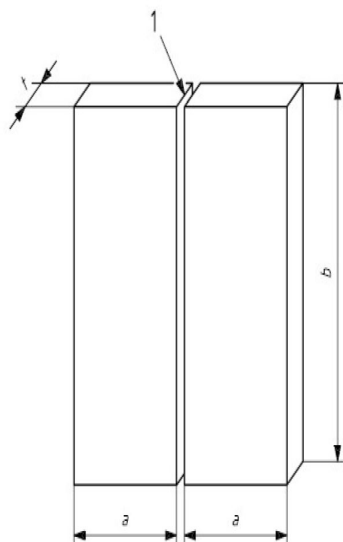

- 1: Joint preparation and fit-up as detailed in the preliminary Welding Procedure Specification
- a: minimum value 150mm
- b: minimum value 350mm
- t: material thickness

The dimensions and shape of the groove is to be representative of the actual repair work.

7.2.2 (1/7/2021)

Preparation and welding of test pieces are to be carried out in accordance with the general condition of repair welding work which it represents.

7.2.3 (1/7/2021)

Welding of the test assemblies and testing of test specimens are to be witnessed by the Surveyor.

7.2.4 (1/1/2001)

The cleaning of the parts to be welded is to be carried out with appropriate procedures which are to be followed in the repair work.

7.3 Examination and tests

7.3.1 (1/7/2021)

Test assembly is to be examined non-destructively and destructively in accordance with Tab 12, Fig 16 and Fig 17:

Table 12 : Type of tests and extent of testing (1/7/2021)

Type of test (1)	Extent of testing
Visual testing	100% as per [7.3.2]
Liquid penetrant testing (2)	100% as per [7.3.2]
Transverse tensile test	Two specimens as per article [7.3.4]
Bend test (3), for cast steel propellers only	Two root and two face specimens as per [7.4.1]
Macro examination	Three specimens as per article [7.3.3]
Impact test, for cast steel propellers only	Two sets of three specimens as per [7.4.2]
Hardness test, for cast steel propellers only	As per [7.4.3]

(1) bend or fracture test are at the discretion of the Society.
 (2) magnetic particle testing may be used in lieu of liquid penetrant testing for martensitic stainless steels.
 (3) for $t \geq 12\text{mm}$, the face and root bend may be substituted by 4 side bend test specimens.

Figure 16 : Test Specimen for cast copper alloy propellers (1/7/2021)

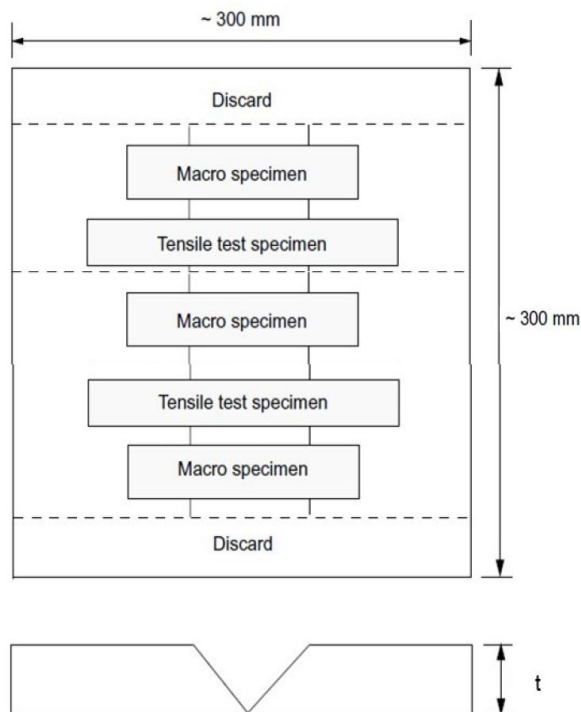
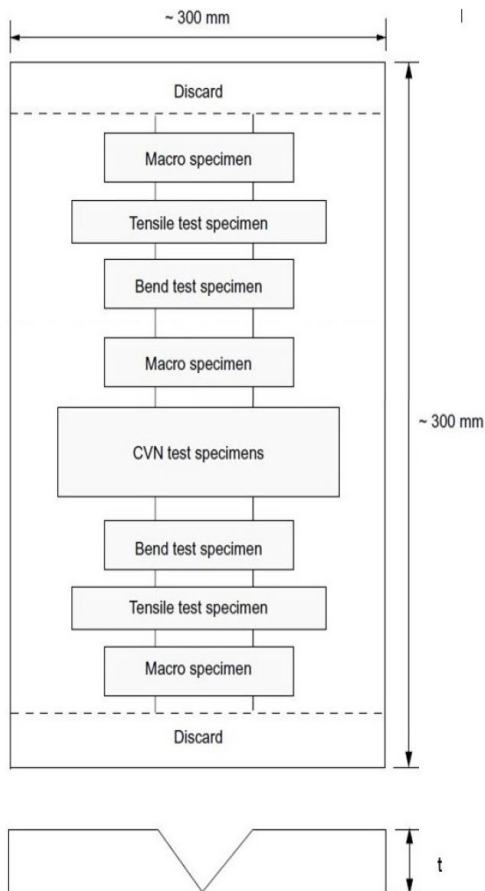

Figure 17 : Test Specimen for cast steel propellers (1/7/2021)



7.3.2 Non-destructive testing (1/7/2021)

Test assembly is to be examined by visual and liquid penetrant testing prior to the cutting of test specimen. In case, that any post-weld heat treatment is required or specified, non-destructive testing is to be performed after heat treatment.

No cracks are permitted. The evaluation of the imperfections detected by liquid penetrant testing, or magnetic particle testing if applicable, is to be assessed in accordance with Ch 4, Sec 2, [1.11] and Ch 4, Sec 2, [3.10] for cast copper alloy propellers and cast steel propellers respectively.

7.3.3 Macroscopic examination (1/7/2021)

Three test specimens are to be prepared (see Fig 16 and Fig 17).

The test specimens are to be prepared and etched on one side to clearly reveal the weld metal, the fusion line, the HAZ, the build up of the runs and the unaffected parent metal. The test specimens are to be examined by eye (aided by low power hand lens if necessary) for any imperfections present in the weld metal and the HAZ. Cracks and lack of fusion are not permitted. Imperfections such as slag inclusions or pores greater than 3 mm are not permitted.

Note 1: a suitable etchant for this purpose is:

- 5 g iron (III) chloride
- 30 ml hydrochloric acid (cone)
- 100 ml water.

7.3.4 Transverse tensile test (1/7/2021)

Two flat transverse tensile test specimens are to be prepared in accordance with Ch 1, Sec 2, [2.1.9]. Alternatively tensile test specimens according to recognized standards acceptable to the Society may be used. The tensile strength is to be not lower than:

- for cast steel propellers: the specified minimum value of the base material;
- for cast copper alloy propellers: the values specified in Tab 13.

The location of the fracture is to be reported (i.e. weld metal, HAZ or base material).

Table 13 : Required tensile strength values for cast copper alloy propellers

ALLOY TYPE	TENSILE STRENGTH, N/mm ² (minimum)
CU 1	370
CU 2	410
CU 3	500
CU 4	550

7.4 Additional test for cast steel propellers

7.4.1 Bend tests (1/7/2021)

Transverse bend tests for butt joints are to be in accordance with Ch 1, Sec 2, [3] or, according to a recognized standard. The mandrel diameter is to be 4 x thickness except for austenitic steels, in which case the mandrel is to be 3 x thickness. The bending angle is to be 180° and when visually inspected after testing, the test specimens are not to reveal any open defects in any direction greater than 3 mm and greater than 2mm in length.

Defects appearing at the corners of a test specimen during testing are to be investigated case by case.

Two root and two face bend specimens are to be tested. For thickness 12 mm and over, four side bend specimens may alternatively be tested.

7.4.2 Impact tests (1/7/2021)

Impact tests are not required, except where the base material is impact tested. Two sets of Charpy V- notch test specimens, one set with the notch positioned in the centre of the weld and one set with the notch positioned in the HAZ (i.e. the mid-point of the notch is to be at 1mm to 2mm from the fusion line) are to be prepared in accordance with Ch 1, Sec 2.

The test temperature and the impact energy are to comply with the requirement specified for the base material.

7.4.3 Hardness tests (1/7/2021)

The macro-section representing the start of welding is to be used for HV 10 hardness testing. A row of indentations is to

be made 2 mm below the surface. At least three individual indentations are to be made in the weld metal, both sides of the HAZ and both sides of the base material. The values are to be reported for information.

7.5 Re-testing

7.5.1 (1/7/2021)

If the test piece fails to comply with any of the requirements in [7], reference is made to re-test procedures given in [2.5].

7.6 Test record

7.6.1 (1/7/2021)

Welding conditions for test assemblies and test results are to be recorded in welding procedure qualification record. Forms of welding procedure qualification records can be taken from the Society's rules or from relevant standards.

7.6.2 (1/7/2021)

A statement of the results of assessing each test piece, including repeat tests, is to be made for each welding procedure qualification records. The relevant items listed for the WPS are to be included.

7.6.3 (1/7/2021)

The welding procedure qualification record is to be signed by the Surveyor witnessing the test and is to include the Society's identification.

7.7 Range of approval

7.7.1 General (1/7/2021)

All the conditions of validity stated below are to be met independently of each other.

Changes outside of the ranges specified are to require a new welding procedure test.

A qualification of a WPS obtained by a manufacturer is valid for welding in workshops or sites under the same technical and quality control of that manufacturer.

7.7.2 Base metal (1/7/2021)

For cast copper alloy propellers, the range of qualification related to base metal is given in Tab 14.

For cast steel propellers, the range of qualification related to base metal is limited to steel grade tested.

Table 14 : Range of qualification for base metal for cast copper alloy propellers

Copper alloy material grade used for qualification	Range of approval
CU 1	CU1
CU 2	CU1; CU2
CU 3	CU3
CU 4	CU4

7.7.3 Thickness (1/7/2021)

The qualification of a WPS carried out on a weld assembly of thickness t is valid for the thickness range given in Tab 15 and Tab 16 for cast copper alloy propellers and cast steel propellers respectively

Table 15 : Range of qualification for thickness for cast copper alloy propellers

Thickness of the test piece, t (mm)	Range of approval
$30 \leq t$	≥ 3 mm

Table 16 : Range of qualification for thickness for cast steel propellers

Thickness of the test piece, t (mm)	Range of approval
$15 < t \leq 30$	3mm to $2t$
$t > 30$	0,5t to $2t$ or 200mm, whichever is the greater

7.7.4 Welding position (1/7/2021)

Approval for a test made in any position is restricted to that position.

7.7.5 Welding process (1/7/2021)

The approval is only valid for the welding process used in the welding procedure test. Single run is not qualified by multi-run butt weld test.

7.7.6 Filler metal (1/7/2021)

The approval is only valid for the filler metal used in the welding procedure test.

7.7.7 Heat input (1/7/2021)

The upper limit of heat input approved is 25% or 15%, for cast copper alloy propellers and cast steel propellers respectively, greater than that used in welding the test piece.

The lower limit of heat input approved is 25% or 15%, for cast copper alloy propellers and cast steel propellers respectively, lower than that used in welding the test piece.

7.7.8 Preheating and interpass temperature (1/7/2021)

The minimum preheating temperature is not to be less than that used in the qualification test.

The maximum interpass temperature is not to be higher than that used in the qualification test.

7.7.9 Post-weld heat treatment (1/7/2021)

The heat treatment used in the qualification test is to be specified in pWPS. Soaking time may be adjusted as a function of thickness.

SECTION 5

APPROVAL OF CO₂ LASER WELDING PROCEDURES

1 General

1.1 Application

1.1.1 The requirements of this Section apply to the approval of CO₂ laser welding procedures for butt- and T-joints in hull construction. Stake welding is not covered by these requirements.

1.2 General requirements

1.2.1 The user's workshop is to furnish proof, by means of a weld procedure approval test and examination of the first production welds, that the welds produced under the normal conditions are sound and have the required mechanical properties.

1.2.2 The approval is granted for a defined range of applications (materials, plate thicknesses, seam preparation, tolerances, etc.) and for specific characteristic welding parameters (laser power, welding speed, welding consumables, etc.), in accordance with the samples welded during the procedure qualification tests.

Normally, changes in essential variables outside the approved range (see Article [7]) require supplementary tests or complete re-qualification.

1.3 Welding personnel

1.3.1 The personnel operating laser welding systems are to have been trained as appropriate and to be capable of making all required adjustments in accordance with the welding specification.

The personnel are also to be in a position to identify any problems in the welding equipment or process and to initiate adequate remedial actions. Proof of this is to be furnished within the scope of the procedure approval tests.

1.4 Welding procedure specification

1.4.1 A welding procedure specification is to be prepared by the Manufacturer and proposed for approval; this document is also referred to as preliminary welding procedure specification (pWPS) and is to be modified and amended during the procedure tests as deemed necessary.

In its final version, the welding procedure specification (WPS) is to include all the welding parameters and main data affecting the quality of welded joints and is to be used as a basis for the laser production welds.

1.5 Parent metal

1.5.1 In addition to the structural steels defined in Ch 2, Sec 1, [2], two new grades of steel have been defined with a narrower range of chemical composition (thus allowing wider flexibility of laser welding parameters).

These grades, designated L24 (normal steel) and L36 (higher strength steel), have the chemical composition indicated in Tab 1; for elements not indicated in this Table, the limits are those of the standard steels defined in Ch 2, Sec 1, Tab 2. The steels are to comply with the requirements in Ch 2, Sec 1, [2].

1.5.2 Steels having chemical composition different from that indicated in Tab 1 may be used provided that satisfactory results are obtained in the approval tests and production welds.

In particular, the following deviation from the standard composition given in Tab 1 may be specially considered subject to an adequate limitation of the welding speed, e.g. 0,6m / 1' for a thickness of 12 mm or 2m / 1' for a thickness less than or equal to 6 mm:

- C ≤ 0,15% subject to a reduction in welding speed and/or increase in applied energy in respect of the values found adequate for the maximum level of C 0,12%,
- S ≤ 0,010% and P ≤ 0,015% for a material thickness less than or equal to 12 mm, or
- S ≤ 0,017% and P ≤ 0,018% for a material thickness less than or equal to 6 mm.

Table 1 : L24 and L36 steel chemical composition

Elements	Ladle analysis (%)
C	≤ 0,12
Mn	0,90 - 1,60 (1)
Si	0,10 - 0,50
S	≤ 0,005
P	≤ 0,010
C _{EQ} (2)	≤ 0,38
P _{cm} (3)	≤ 0,22
(1) Manganese may be reduced to 0,70% for L24 grade consistent with the lowest values used in the weld procedure test.	
(2) $C_{EQ} = C + \frac{Mn}{6} + \frac{Cr + Mo + V}{5} + \frac{Ni + Cu}{15}$ %	
(3) $P_{cm} = C + \frac{Si}{30} + \frac{Mn}{20} + \frac{Cu}{20} + \frac{Ni}{60} + \frac{Cr}{20} + \frac{Mo}{15} + \frac{V}{10} + 5B$ %	

1.6 Welding consumables

1.6.1 Welding consumables and auxiliary materials are to be approved by the Society and are to be clearly defined in the WPS.

2 Welding procedure

2.1 General

2.1.1 Prior to fabrication, welding procedure tests are to be carried out under the Society's supervision at the user's workshop under fabrication conditions.

2.1.2 Prior to the welding of the procedure tests, a test program is to be submitted to the Society for examination and approval.

2.1.3 The application of the welding procedure is subject to the acceptance of the first production welds.

2.2 Assembly and welding

2.2.1 Butt-joint test assemblies and/or T-joint test assemblies are to be welded in the procedure test in accordance with the range of application applied for approval.

2.2.2 Test assemblies are to be of a sufficient size to ensure reasonable heat distribution during welding and to provide for the required test specimens, after sufficient discard at the ends.

Unless otherwise agreed, the dimensions are to be in accordance with [4.1.2] and [5.1.1].

2.2.3 Welding is to be carried out in accordance with the WPS and under the general conditions of production welding which they represent.

2.2.4 The type of joint preparation including tolerances is to be representative of the fabrication welds. Maximum and minimum values of tolerances are to be incorporated in the weld procedure test.

Where gaps are required, the minimum and the maximum values are to be verified on two procedure tests.

2.2.5 The plates are to be held in place by clamps, or other suitable holding devices, or by tack welds as provided for fabrication welding. If tack welds are to be used in the fabrication, they are to be included in the test pieces.

2.2.6 The welding parameters are to be recorded and are to be in accordance with the WPS. Each test piece is to contain at least one sudden stop/restart of the welding process.

3 Non-destructive examinations

3.1 General

3.1.1 Prior to the cutting of the test specimens, non-destructive examinations are to be carried out over the entire length of the weld.

3.1.2 Where automatic non-destructive examinations are used in fabrication (e.g. ultrasonic), the test piece is to be subjected to such examinations.

3.2 Visual examination

3.2.1 Visual examination is to be performed on all butt- and T-joints for external imperfections (cracks, porosity, lack of penetration, undercuts, excess weld metal, excessive penetration or root reinforcement, linear misalignment, sagging, incomplete filled groove, root concavity shrinkage groove, etc.) in accordance with ISO 13919-1:1996. Imperfections are to be within the limits specified for quality level C (intermediate).

3.3 Radiographic examination

3.3.1 Radiographic examination is to be performed on all butt-joints in accordance with EN ISO 17636-1:2013 using X rays and fine grain films (type C according to EN ISO 11699-1:2011) with lead screens. Imperfections (cracks, including crater cracks, porosity and gas pores, shrinkage cavities, solid inclusions, lack of fusion, lack of penetration, etc.) are to be evaluated in accordance with ISO 13919-1:1996, mentioned in [3.2.1], and are to be within the limits specified for quality level C (intermediate).

Any linear indications on the film originating from solidification imperfections are considered as cracks and are not acceptable.

3.4 Ultrasonic examination

3.4.1 Ultrasonic examination is to be performed on all full penetration T-joints in accordance with EN ISO 17640:2010 using straight probes (from the face plate side) and angle probes (from the web side).

Ultrasonic examination of butt-joints may also be required by the Society. The test methods (calibration, sensitivity, setting, testing direction, angle of incidence, etc.) are to be specified depending on the material thickness to be joined and are to be submitted to the Society for approval. Additional samples for macro examination are to be taken from areas showing significant indications.

3.5 Magnetic particle

3.5.1 Magnetic particle examination is to be performed on all butt- and T- joints in accordance with EN ISO 17638:2009 for surface imperfections such as cracks, including crater cracks, and lack of fusion and/or penetration. Where necessary (in the case of doubt), the weld reinforcement of butt welds is to be ground flush with the surface after visual, radiographic and ultrasonic examination. Linear indications are not acceptable.

4 Butt weld procedure test

4.1 Assembly

4.1.1 The weld direction is to be perpendicular to the rolling direction of the plate and is to be marked on the test piece.

Where impact tests are prescribed for the base metal in the transverse direction, the weld direction is to be parallel to the rolling direction of the plate (see Fig 1).

Figure 1 : Butt weld test assembly with Charpy impact test

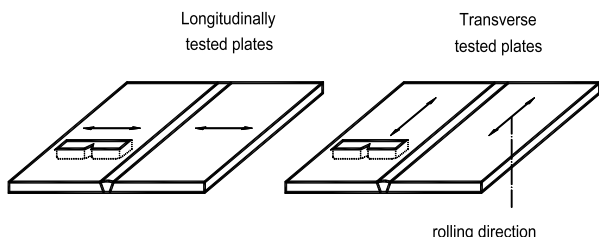

4.1.2 The dimension of the butt weld test assembly is to be in accordance with Fig 2.

The dimensions in Fig 2 are as follows:

- W min. = 1000 mm
- L min. = 1500 mm
- D max. = 50 mm.

4.2 Examinations and tests

4.2.1 General

Non-destructive examinations and destructive tests are to be in accordance with the requirements of Tab 2, while the location of the test specimens is to be in accordance with Fig 2.

4.2.2 Non-destructive examinations

The requirements in Article [3] are to be complied with. Special attention is to be paid to the stop/restart positions with respect to profile, proper fusion and absence of cracks and porosity.

4.3 Tensile tests

4.3.1 (1/10/2019)

Transverse tensile test specimens are to be in accordance with Ch 1, Sec 2, [2.1.9]; the testing method is to be in accordance with Ch 1, Sec 2.

4.3.2 The tensile strength is to be not lower than the specified minimum tensile strength of the parent material. The location of the fracture is to be reported, i.e. weld metal, HAZ, parent metal.

Table 2 : Examinations and tests

Type of examination or test	Extent of examination or test
Visual examination	100%
Radiographic examination	100%
Magnetic particle examination	100%
Transverse tensile test	2 specimens
Transverse bend tests (1)	2 root and 2 face specimens
Longitudinal bend test	1 face specimen
Impact tests (2)	3 sets
Macro examination	3 sections
Hardness test	2 sections
(1) The face and root bends are preferably to be replaced by 4 side bends for $t \geq 12$ mm.	
(2) 3 sets of 3 specimens as per [4.5.1].	

4.4 Bend tests

4.4.1 Bend test (1/10/2019)

Transverse, side and longitudinal bend specimens are to be machined to the dimensions given in Ch 1, Sec 2, [3].

The test specimens are to be bent on a mandrel having a diameter 3,5 times the thickness of the specimen; the bending angle is to be 180°.

Figure 2 : Butt weld test assembly

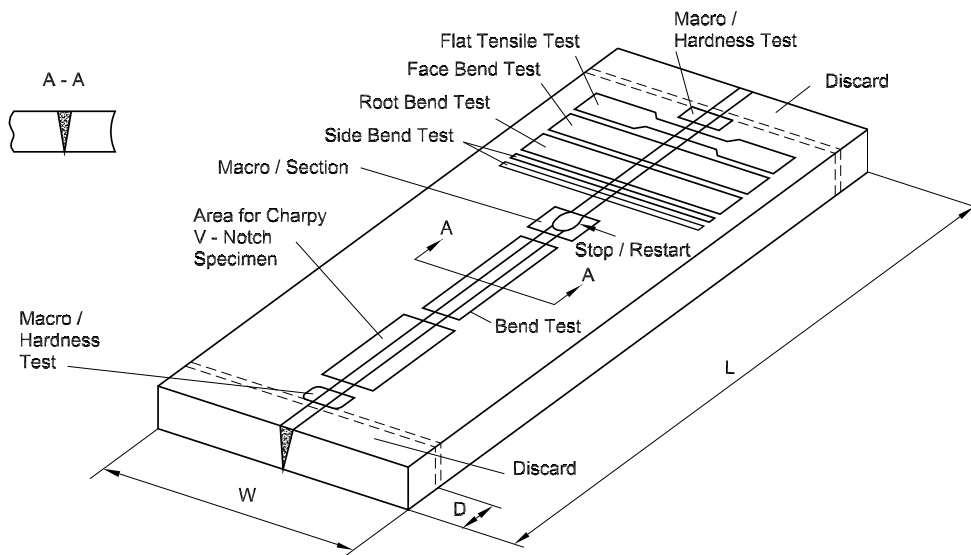

4.4.2 During the test, the specimens are not to reveal any open imperfection, in any direction, greater than 2 mm. Defects appearing at the corner of the test specimen are disregarded.

4.5 Impact tests

4.5.1 Charpy V-notch impact tests are to be taken 1 mm below the surface of the sample transverse to the weld and with the notch perpendicular to the material surface; they are to be machined to the dimensions indicated in Ch 1, Sec 2, [4.2.1].

Three sets of Charpy V-notch specimens, each set including 3 specimens, are to be taken as follows:

- one set with the notch along the weld metal centre line with tolerance $\pm 0,1\text{mm}$
- one set with the notch in the heat affected zone (HAZ)
- one set with the notch in the parent metal.

The direction of fracture is to coincide with the weld direction (see Fig 3). The parent material specimens are to have the same orientation as the specimens from the weld joint.

Figure 3 : Fracture direction of Charpy impact tests

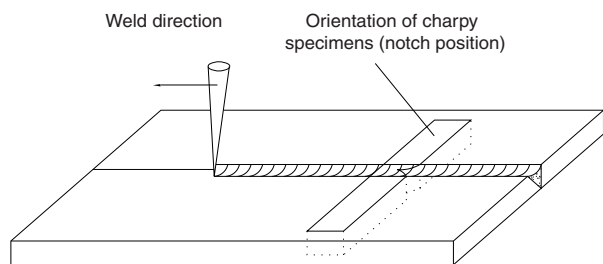

4.5.2 The test temperature and the results are to comply with the requirements specified for the parent metal.

4.5.3 Requirements for reduced Charpy V specimens are given in Ch 1, Sec 2, [4.2.2].

4.5.4 The Society may require additional tests, e.g. Charpy tests with other notch locations, and other or additional temperatures or CTOD tests.

4.6 Hardness measurements

4.6.1 Hardness test

The measurement is to be carried out in accordance with ISO 6507-1 on the macro sections required in [4.7]; the Vickers method HV5 is to be used.

The indentations are to be made in the weld, heat affected zones (HAZ) and the parent metal, with the object of measuring and recording the range of values in the weld joint (see Fig 4). For butt welds, the upper and lower rows are to transverse 2 mm maximum below the surface, depending on the plate thickness.

For each row of indentations, a minimum of 3 individual indentations is required in the weld, both sides of the HAZ and the parent metal.

For the HAZ, the indentations are to be placed as close as possible to the fusion line.

Figure 4 : Butt weld hardness indentations

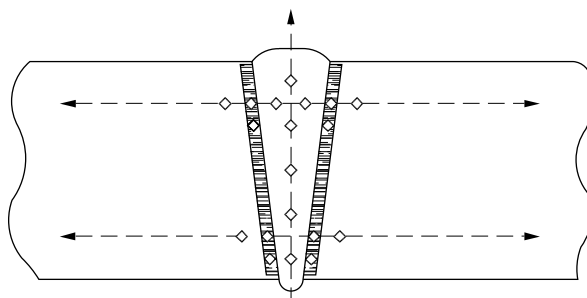

4.6.2 Where no filler metal or low hydrogen welding consumables (H5) are used in the procedure, values not higher than 380HV are considered acceptable; one individual value not higher than 400HV is accepted for each section.

Values not higher than 350HV are required in all other cases.

4.7 Metallographic examination

4.7.1 The three macro sections are to be taken as shown in Fig 2.

One section is to be a length of weld including a stop/restart position. This longitudinal section is to be cut as shown in Fig 5 and examined at the mid-thickness of the plate.

Figure 5 : Longitudinal mid-thickness macro section

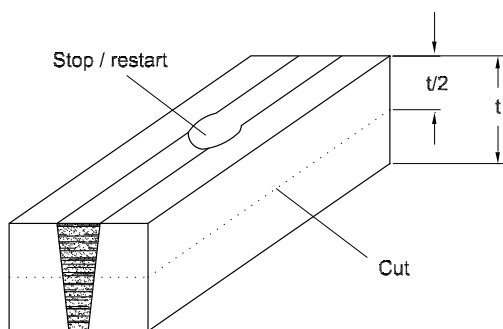

4.7.2 The test specimens are to be prepared and etched on one side only to clearly reveal the fusion line, the HAZ, the solidification structure of the weld metal and the unaffected parent metal.

4.7.3 The sections are to be examined by the naked eye (or by low power hand lens if deemed necessary) for any imperfection present in the weld metal and HAZ and for unsatisfactory profile features. Any imperfections are to be assessed in accordance with Article [3].

4.7.4 The weld shape is to be within the limits specified in Fig 6. For thicknesses up to 8 mm, lower values for "d" and "d₁" may be accepted at the discretion of the Society.

Figure 6 : Weld shape limitations

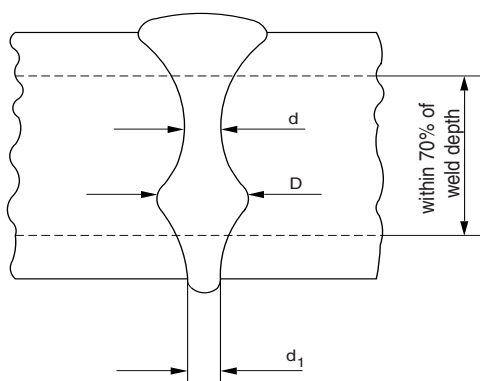

- d : Minimum weld width, with $d \geq 1,5$ mm
- d₁ : Weld root width, with $d_1 \geq 1,0$ mm

- D/d : Secondary wide zone "bulge", if bulging occurs
- $D/d \leq 1,2$

5 Fillet weld procedure test

5.1 Assembly

5.1.1 The dimensions of the T-joint fillet weld test assembly are to be in accordance with Fig 7.

The dimensions in Fig 7 are as follows:

- W min. = 300 mm
- L min. = 1000 mm
- D max. = 50 mm.

Figure 7 : T-joint test assembly

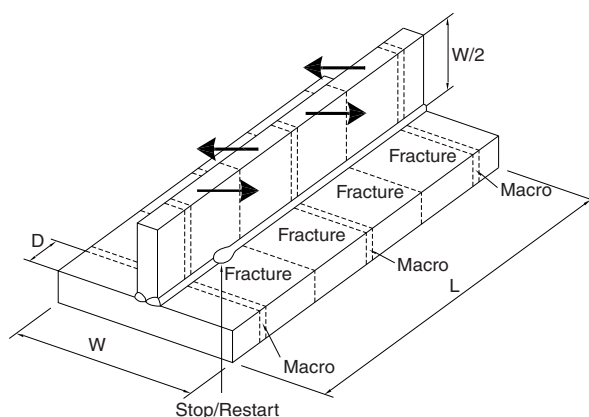

5.2 Examinations and tests

5.2.1 General

Non-destructive examinations and destructive tests are to be in accordance with the requirements of Tab 3, while the location of the test specimens is to be in accordance with Fig 7.

Table 3 : Examinations and tests

Type of examination or test	Extent of examination or test
Visual examination	100%
Magnetic particle examination	100%
Ultrasonic examination (for full penetration welds)	100%
Macro examination	3 sections
Hardness test	3 sections
Break test	4 specimens (1)
(1) One specimen is to be taken from the stop/restart position.	

5.2.2 Non-destructive examination

The requirements in Article [3] are to be complied with. Special attention is to be paid to the stop/restart positions

with respect to profile, proper fusion and absence of crater defects.

5.2.3 Macro examination

The three macro sections are to be taken as shown in Fig 7.

Two sections are to be taken from the ends adjacent to the discards, the third from the middle of the length.

5.2.4 Hardness test

Hardness indentations are to be made as shown in Fig 8 in accordance with [4.6.1], as appropriate. All hardness values are to be recorded. The values are to comply with the requirements in [4.6.2].

Figure 8 : Fillet weld hardness indentations

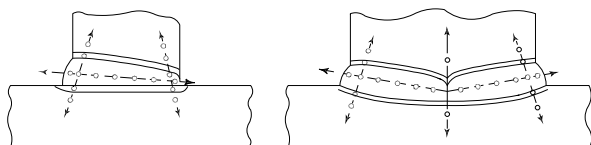

5.2.5 Break test

Break test specimens are to be taken from the length of the welded assembly remaining after removal of the macro sections. Four test specimens (not less than 100 mm each in length) are to be taken and fractured by folding the upright plate in alternate directions onto the through plate (see Fig 7).

A saw cut may be made to facilitate breaking in accordance with Fig 9.

The fracture surfaces are to be examined for possible defects which are to be assessed in accordance with Article [3].

Figure 9 : Break test

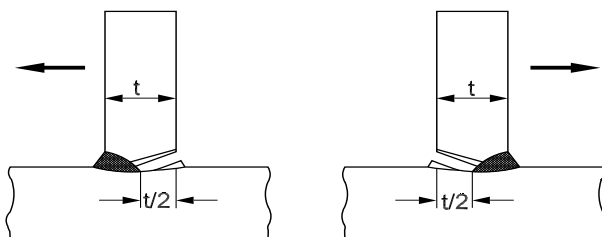

Note 1: If a break in the weld cannot be obtained, an alternative is to machine the base plate flush to the web and to radiographic the weld in the direction of weld centre line.

6 Re-testing

6.1 Non-destructive examinations

6.1.1 If the qualification assembly fails to comply with any of the requirements for visual examination or NDE, one extra assembly is to be welded and subjected to the same examination.

If this additional assembly does not comply with the relevant requirements, the welding procedure is not approved by the Society and is to be modified before further consideration is given to a new test assembly for qualification.

6.2 Destructive tests

6.2.1

When a destructive test (other than Charpy V for which the requirements in Sec 2, [3.3.2] apply) does not meet the requirements, two additional specimens are to be obtained for each one that failed; these tests are to be taken from the same assembly. For acceptance, both tests are to give satisfactory results.

7 Range of approval

7.1 Parent metal

7.1.1 In any steel strength categories (normal and higher), qualification of a steel of lower toughness requirements will qualify the grades of higher toughness but not vice versa, provided that the impact test temperatures used satisfy the requirements of the higher grade.

7.1.2 A change in the parent metal chemical composition (compared to those used to qualify the welding procedure) beyond the values specified in Tab 4 will require re-qualification.

A decrease in alloying content is acceptable.

7.2 Thickness

7.2.1 The approval of a procedure carried out on a welded assembly of thickness t is valid for the range $0,80t$ to t .

Speed and power may be changed within the limitations in [7.6.2].

7.3 Edge preparation and surface condition

7.3.1 Cutting process

Milled surfaces are considered the best method of edge preparation. The cutting processes are as follows:

- thermal cut
- thermal cut and sand blasted
- thermal cut and ground
- milled.

Other cutting methods, such as mechanical cutting (shearing), may be considered analogously depending on their edge geometry and surface condition. A change in the cutting process requires new qualification.

7.3.2 Surface condition

Any major change in surface condition, such as a change from uncoated to shop primer coated surfaces, requires new qualification. In this context, special attention is to be paid to T-joint configurations.

7.4 Joint type, bevel

7.4.1 Butt-joints cannot cover T-joints and vice versa.

7.4.2 Any change in joint geometry with respect to that specified in the welding procedure qualification report (WPQR) requires new qualification.

7.5 Welding procedure

7.5.1 Laser machine

A procedure approved for use on one laser machine is valid for that machine and beam shape only. The approval is valid for the focusing system used at the approval tests.

7.5.2 Modification of laser machine

Modifications carried out on an approved laser machine or the use of other laser machines having the same technical specification (from the laser beam technology point of view) only required a reduced re-approval test, if the beam parameters are within the approved range.

Table 4 : Range of qualified chemical composition

Variable	Range qualified
C	+ 0,010 %
S	+ 0,001 %
P	+ 0,001 %
S/Mn + P	+ 0,002 %
C _{EQ}	+ 0,025 %
Pcm	+ 0,010 %

7.6 Welding parameters

7.6.1 General

Variations within the limits described below in the welding speed, laser power, focusing parameters and wire feed rate are allowed to accommodate changes in material thickness or fit-up, without need for re-approval. Monitoring of welding parameters within a given procedure setting is to be applied.

7.6.2 Laser power and welding speed

The parameter (laser power / thickness x speed) is to be within the range 90-120% of that originally approved (while also maintaining the welding speed above 0,6m/1').

For each resetting of parameters, one test sample is to be taken and verified for weld profile shape and freedom from defects by non-destructive examination.

7.6.3 Wire feed speed

The wire feed speed is to be maintained within the limits established by the procedure tests.

7.6.4 Focusing optic and focus position

The focusing parameters are to be kept within the limits specified in accordance with recognised standards.

7.6.5 Number of runs

A change in the number of passes requires a new approval.

7.6.6 Process and shielding gas

Any change in shielding gas or plasma control gas composition requires a new approval.

A change in the flow rate up to 10% is admitted.

7.6.7 Welding position

A change of the welding position requires a new approval.

7.6.8 Welding consumables

Any change of welding consumables requires a new approval.

7.6.9 Other variables

The range of approval related to other variables may be taken according to established practice as represented in recognised standards.

SECTION 6

QUALIFICATION SCHEME FOR WELDERS OF HULL STRUCTURAL STEELS

1 Scope

1.1 Application

1.1.1 (1/1/2018)

This Section gives requirements for a qualification scheme for welders intended to be engaged in the fusion welding of the following steels:

- Normal and higher strength hull structural steels, including corrosion resistant steels;
- YP47 steel plates for longitudinal structural members in the upper deck region of container carriers;
- Steel forgings for hull structures;
- Steel castings for hull structures.

1.1.2 (1/1/2018)

This qualification scheme does not cover welders engaged in oxy-acetylene welding.

1.1.3 (1/1/2022)

This qualification scheme does not cover welding of pipes and pressure vessels.

1.1.4 (1/1/2022)

Alternative welding Standards or Codes are to be applied in full, cross-mixing requirements of Standards and Codes is not permitted.

1.1.5 (1/1/2022)

Existing qualifications are to be renewed in accordance with the requirements in this section when they become due.

2 General

2.1

2.1.1 (1/1/2018)

Those welders intended to be engaged in welding of hull structures in shipyards and manufacturers shall be tested and qualified in accordance with this scheme and issued with a qualification certificate endorsed by the Society.

2.1.2 (1/1/2022)

The welding operator responsible for setting up and/or adjustment of fully mechanized and automatic equipment, such as submerged arc welding, gravity welding, electro-gas welding and MAG welding with auto-carriage, etc., must be qualified whether he operates the equipment or not. However a welding operator, who solely operates the equipment without responsibility for setting up and/or adjustment, does not need qualification provided that he has experience of the specific welding work concerned and

the production welds made by the operators are of the required quality.

The qualification test and approval range of the welding operator are left to the discretion of the Society with reference to ISO 14732:2013.

2.1.3 (1/1/2018)

This Section is applicable to welding of hull structures both during new construction and the repair of ships.

2.1.4 (1/1/2018)

The training of welders, control of their qualification and maintenance of their skills are the responsibility of shipyards and manufacturers. The Society Surveyor is to verify and be satisfied that the welders are appropriately qualified.

2.1.5 Equivalence of national or international standards to this Section (1/1/2022)

Welders or welding operators qualified in accordance with national or international welder qualification standards may also be engaged in welding of hull structures at the discretion of the Society provided that standard is considered equivalent to those provided in this Section from technical perspective covering examination, testing and range approval.

Even if the requirements stipulated in the standards are applied, the requirement for revalidation of welders' qualification are to be in accordance with [6.2.1].

3 Range of qualification of welders

3.1 Application

3.1.1 (1/1/2018)

A welder is to be qualified in relation to the following variables of welding:

- a) base metal
- b) welding consumables type
- c) welding process
- d) type of welded joint
- e) plate thickness
- f) welding position

3.1.2 (1/1/2018)

Base metals for qualification of welders or welding operators are combined into one group with a specified minimum yield strength $ReH \leq 460 \text{ N/mm}^2$. The welding of any one metal in this group covers qualification of the welder or welding operator for the welding of all other metals within this group.

3.1.3 (1/1/2018)

For manual metal arc welding, qualification tests are required using basic, acid or rutile covered electrodes. The type of covered electrodes (basic, acid or rutile) included in the range of approval is left at the discretion of the Society.

Welding with filler material qualifies for welding without filler material, but not vice versa.

3.1.4 (1/1/2018)

The welding processes for welder's qualification are to be classified in Tab 1 as,

M - Manual welding

S - Semi-automatic welding/Partly mechanized welding

T - TIG welding

Each testing normally qualifies only for one welding process. A change of welding process requires a new qualification test.

Table 1 : Welding processes for welder's qualification (1/1/2022)

Symbol	Welding process in actual welding works		ISO 4063:2009
M	Manual welding	Manual metal arc welding (metal arc welding with covered electrode)	111
S	Partly mechanized welding	Metal inert gas (MIG) welding	131
		Metal active gas (MAG) welding	135,138 (1)
		Flux cored arc (FCA) welding	136 (2)
T	TIG welding	Tungsten inert gas (TIG) welding	141
The Society may require separate qualification for solid wires, metal-cored wires and flux-cored wires as follows: (1) A change from MAG welding with solid wires (135) to that with metal cored wires (138), or vice versa is permitted. (2) A change from a solid or metal cored wire (135/138) to a flux cored wire (136) or vice versa requires a new welder qualification test			

3.1.5 (1/1/2018)

The types of welded joint for welder's qualification are to be classified as shown in Tab 2 in accordance with the qualification test.

Welders engaged in full/partial penetration T welds shall be qualified for butt welds for the welding process and the position corresponding to the joints to be welded.

Table 2 : Types of welded joint for welder's qualification (1/1/2018)

Type of welded joint used in the test assembly for the qualification test				Type of welded joint qualified
Butt weld	Single sided weld	With backing	A	A, C, F
		Without backing	B	A, B, C, D, F
	Double sided weld	With gouging	C	A, C, F
		Without gouging	D	A, C, D, F
Fillet weld	-	-	F	F

3.1.6 (1/1/2018)

For fillet welding, welders who passed the qualification tests for multi-layer technique welding can be deemed as qualified for single layer technique, but not vice versa.

3.1.7 (1/1/2018)

The qualified plate thickness range arising from the welder qualification test plate thickness is shown in Tab 3.

Table 3 : Plate thicknesses for welder's qualification (1/1/2018)

Thickness of test assembly T (mm)	Qualified plate thickness range t (mm)
$T < 3$	$T \leq t \leq 2T$
$3 \leq T < 12$	$3 \leq t \leq 2T$
$12 \leq T$	$3 \leq t$

3.1.8 (1/1/2018)

The welding positions qualified as a result of the actual welding position used in a satisfactory welder's qualification test, are shown in Tab 4 and Tab 5. Diagrams showing the definitions of weld position used in Tab 4 and Tab 5 are shown in Fig 1.

Table 4 : Qualified welding positions when testing with butt welding (1/1/2018)

Qualification Test Position with butt weld	Qualified welding positions in actual welding works	
	Butt welds	Fillet welds
PA	PA	PA, PB
PC	PA, PC	PA, PB, PC
PE	PA, PC, PE	PA, PB, PC, PD, PE
PF	PA, PF	PA, PB, PF
PG	PG	PG

Table 5 : Qualified welding positions when testing with fillet welding (1/1/2018)

Qualification Test Position with fillet weld	Qualified welding positions in actual welding works
	Fillet welds
PA	PA
PB	PA, PB
PC	PA, PB, PC
PD	PA, PB, PC, PD, PE
PE	PA, PB, PC, PD, PE
PF	PA, PB, PF
PG	PG

The Society may require a qualification test with fillet welding for welders who are employed to perform fillet welding only. Welders engaged in welding of T joints with partial or full penetration are to be qualified for butt welding.

3.1.9 (1/1/2018)

A welder qualified for butt or fillet welding can be engaged in tack welding for the welding process and position corresponding to those permitted in his certificate.

Alternatively, welders engaged in tack welding only can be qualified on the test assemblies shown in Fig 5 or Fig 6.

Figure 1 : Welding positions

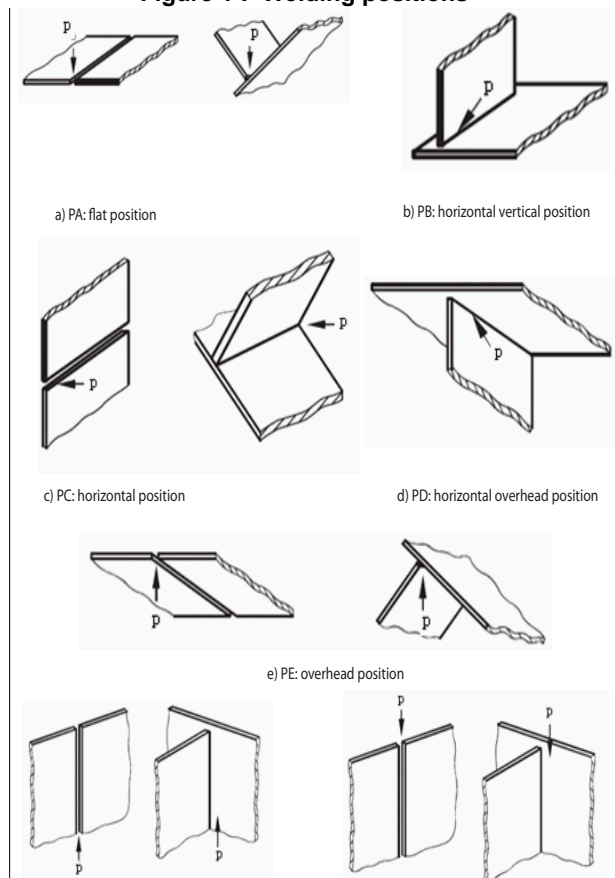

4 Qualification test

4.1 General

4.1.1 (1/1/2018)

Welding of the test assemblies and testing of test specimens shall be witnessed by the Surveyor.

4.2 Test assemblies

4.2.1 (1/1/2018)

Test assemblies for butt welds and for fillet welds are to be prepared as shown in Fig 2, Fig 3 and Fig 4 in each qualification test.

4.2.2 (1/1/2018)

Test assemblies for butt tack welds and for fillet tack welds are to be prepared as shown in Fig 5 and Fig 6.

Figure 2 : Dimensions and types of test assembly for butt welds ($T < 12\text{mm}$) (1/1/2018)

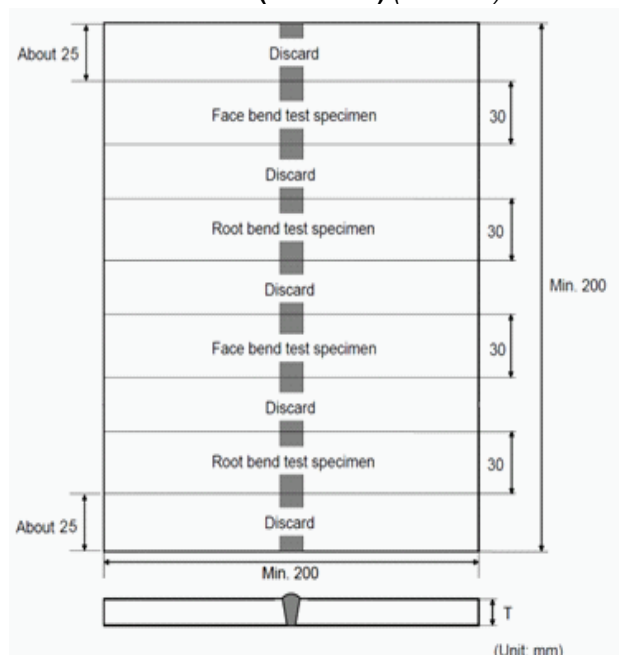

Figure 3 : Dimensions and types of test assembly for butt welds ($T \geq 12\text{mm}$) (1/1/2018)

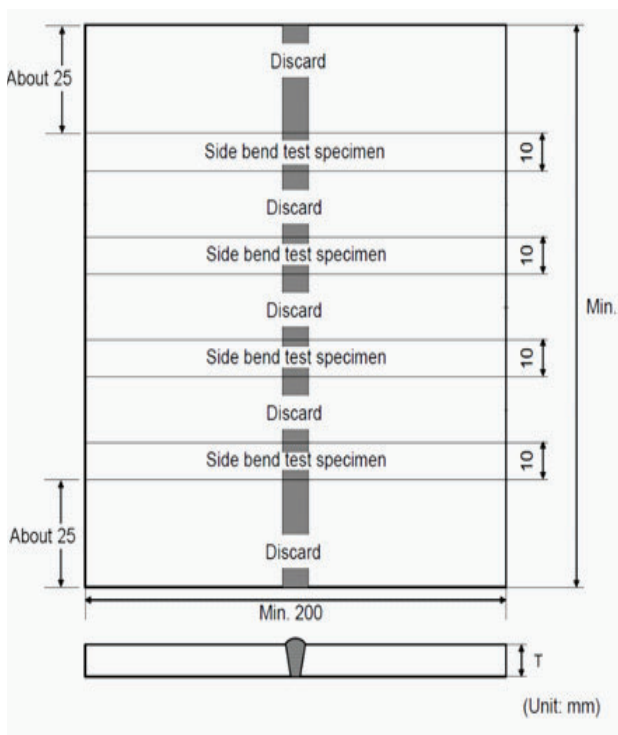

Figure 4 : Dimensions and types of test assembly for fillet welds (1/1/2018)

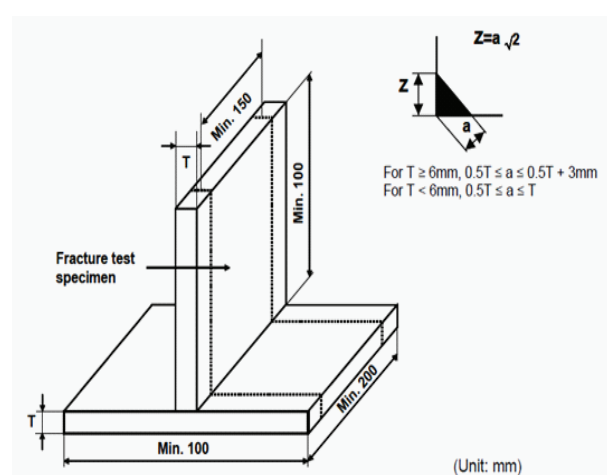

Figure 5 : Dimensions and types of test assembly for tack butt welds (1/1/2018)

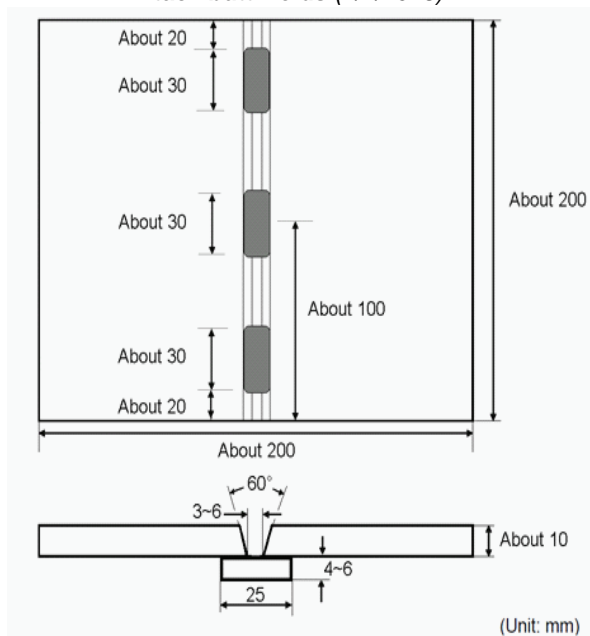
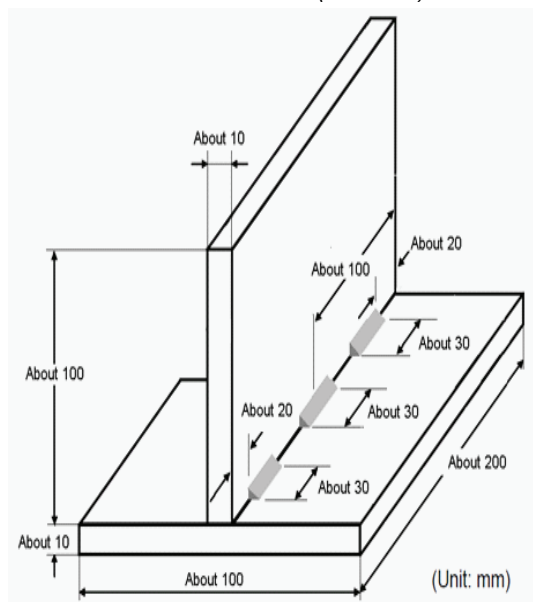

Figure 6 : Dimensions and types of test assembly for tack fillet welds (1/1/2018)



4.2.3 (1/1/2018)

Testing materials and welding consumables shall conform to one of the following requirements or to be of equivalent grade approved by the Society.

a) Testing materials

- Hull structural steels specified in Ch 2, Sec 1, [2] and Ch 2, Sec 1, [12]
- Hull structural forged steels specified in Ch 2, Sec 3, [2]
- Hull structural cast steels specified in Ch 2, Sec 4, [2]
- Hull structural steels with specified minimum yield point 460 N/mm² specified in Ch 2, Sec 1, [11]

b) Welding consumables

- Consumables for hull structural steels specified in Sec 2
- Consumables for YP47 steels specified in Ch 2, Sec 1, [11.4.3].

4.2.4 (1/1/2018)

The welder qualification test assembly is to be welded according to a welding procedure specification (WPS or pWPS) simulating the conditions in production, as far as practicable.

4.2.5 (1/1/2018)

Root run and capping run need each to have a minimum of one stop and restart. The welders are allowed to remove minor imperfections only in the stop by grinding before restart welding.

4.3 Examination and test

4.3.1 (1/1/2018)

The test assemblies specified in [4.2] shall be examined and tested as follows:

a) For butt welds

- Visual examination
- Bend test

Note 1: Radiographic test or fracture test may be carried out in lieu of bend test except the gas-shielded welding processes with solid wire or metal cored wire.

b) For fillet welds

- Visual examination
- Fracture test

Note 2: Two macro sections may be taken in lieu of the fracture test.

c) For tack welds

- Visual examination
- Fracture test

Additional tests may be required, at the discretion of the Society.

4.3.2 Visual examination (1/1/2022)

The welds shall be visually examined prior to the cutting of the test specimen for the bend test and fracture test. The result of the examination is to show the absence of cracks or other serious imperfections.

Imperfections detected are to be assessed in accordance with quality level B in ISO 5817:2014, except for the following imperfection types for which level C applies:

- Excess weld metal
- Excess penetration
- Excessive convexity
- Excessive throat thickness.

4.3.3 Bend test (1/1/2018)

Transverse bend test specimens are to be in accordance with Ch 1, Sec 2, [3].

The mandrel diameter to thickness ratio (i.e. D/T) is to be that specified for welding consumable (Sec 2 and Ch 2, Sec 1, [11]) approvals +1.

Two face bend test and two root bend test specimens are to be tested for initial qualification test, and one face and one root bend test specimens for extension of approval. For thickness 12mm and over, four side specimens (two side specimens for extension of approval) with 10 mm in thickness may be tested as an alternative.

At least one bend test specimen shall include one stop and restart in the bending part, for root run or for cap run.

The test specimens are to be bent through 180 degrees. After the test, the test specimens shall not reveal any open defects in any direction greater than 3mm. Defects appearing at the corners of a test specimen during testing should be investigated case by case.

4.3.4 Radiographic test (1/1/2022)

When radiographic testing is used for butt welds, imperfections detected shall be assessed in accordance with ISO 5817:2014, level B.

4.3.5 Fracture test (Butt welds) (1/1/2022)

When fracture test is used for butt welds, full test specimen in length is to be tested in accordance with ISO 9017:2017. Imperfections detected shall be assessed in accordance with ISO 5817:2014, level B.

4.3.6 Fracture test (Fillet welds) (1/1/2022)

The fracture test is to be performed by folding the upright plate onto the through plate.

Evaluation shall concentrate on cracks, porosity and pores, inclusions, lack of fusion and incomplete penetration. Imperfections that are detected shall be assessed in accordance with ISO 5817:2014, level B.

4.3.7 Macro examination (1/1/2018)

When macro examination is used for fillet welds, two test specimens are to be prepared from different cutting positions; at least one macro examination specimen shall be cut at the position of one stop and restart in either root run or cap run. These specimens are to be etched on one side to clearly reveal the weld metal, fusion line, root penetration and the heat affected zone.

Macro sections shall include at least 10mm of unaffected base metal.

The examination is to reveal a regular weld profile, through fusion between adjacent layers of weld and base metal, sufficient root penetration and the absence of defects such as cracks, lack of fusion etc.

4.4 Retest

4.4.1 (1/1/2018)

When a welder fails a qualification test, the following shall apply.

- a) In cases where the welder fails to meet the requirements in part of the tests, a retest may be welded immediately, consisting of another test assembly of each type of welded joint and position that the welder failed. In this

case, the test is to be done for duplicate test specimens of each failed test.

All retest specimens shall meet all of the specified requirements.

- b) In cases where the welder fails to meet the requirements in all parts of the required tests or in the retest prescribed in [4.4.1] a), the welder shall undertake further training and practice.
- c) When there is specific reason to question the welder's ability or the period of effectiveness has lapsed, the welder shall be re-qualified in accordance with the tests specified in [4.2] and [4.3].

4.4.2 (1/1/2018)

Where any test specimen does not comply with dimensional specifications due to poor machining, a replacement test assembly shall be welded and tested.

5 Certification

5.1

5.1.1 (1/1/2022)

Qualification certificates are normally issued when the welder has passed the qualification test in accordance with the Society's Rules. Each Shipyard and Manufacturer shall be responsible for the control of the validity of the certificate and the range of the approval.

5.1.2 (1/1/2018)

The following items shall be specified in the certificate:

- a) Range of qualification for base metal, welding processes, filler metal type, types of welded joint, plate thicknesses and welding positions.
- b) Expiry date of the validity of the qualification.
- c) Name, date of birth, identification and the photograph of the welder.
- d) Name of shipbuilder / manufacturer.

5.1.3 (1/1/2018)

When a certificate is issued, the relative documents such as test reports and/or re-validation records shall be archived as annexes to the copy of certificate according to the rules of the Society.

5.1.4 (1/1/2018)

The status of approvals of each individual qualification is to be demonstrated to the Classification Society when requested.

6 Period of Validity

6.1 Initial approval

6.1.1 (1/1/2022)

Normally the validity of the welder's approval begins from the issue date of qualification certificate when all the required tests are satisfactorily completed.

6.1.2 (1/1/2022)

The certificate is to be signed at six-month intervals by the shipyards/manufacturers personnel who is responsible for

production weld quality provided that all the following conditions are fulfilled:

- a) The welder shall be engaged with reasonable continuity on welding work within the current range of approval. An interruption for a period no longer than six months is permitted.
- b) The welder's work shall in general be in accordance with the technical conditions under which the approval test is carried out.
- c) There shall be no specific reason to question the welder's skill and knowledge.

6.1.3 (1/1/2022)

If any of these conditions are not fulfilled, the Society is to be informed and the certificate is to be cancelled.

6.1.4 (1/1/2022)

The validity of the certificate may be maintained in agreement with the Society as specified in [6.2]. The chosen maintenance option of qualification in accordance with [6.2.1] a) or b) or c) is to be stated on the certificate at the time of issue.

6.2 Maintenance of the approval

6.2.1 (1/1/2022)

Revalidation shall be carried out by the Society. The skill of the welder shall be periodically verified by one of the following options:

- a) The welder shall be re-tested every 3 years.
- b) Every 2 years, two welds made during the last 6 months of the 2 years validity period shall be tested by radiographic or ultrasonic testing or destructive testing and shall be recorded. The weld tested shall reproduce the initial test conditions except for the thickness. These tests revalidate the welder's qualifications for an additional 2 years.
- c) A welder's qualification for any certificate shall be valid as long as it is signed according to [6.1.2] subject that all the following conditions are fulfilled. In this option, the fulfilment of all the conditions is to be verified by the Society. The frequency of verification by the Society

is to be no longer than 3 years and is to be agreed between the Society and the shipyards/manufacturers.

- 1) The welder is working for the same shipyard/manufacturer which is responsible for production weld quality as indicated on his or her qualification certificate.
- 2) Society shall verify that the welder quality management system of the shipyard/manufacturer includes as minimum:
 - A designated person responsible for the coordination of the welder quality management system
 - List of welders and welding supervisors in shipyard/manufacturer
 - If applicable, list of subcontracted welders
 - Qualification certificate of welders and description of the associated management system
 - Training requirements for welder qualification programme
 - Identification system for welders and WPS used on welds
 - Procedure describing the system in place to monitor each welder performance based on results of welds examination records (e.g. repair rate, etc.) including the criteria permitting the maintenance of the welder qualification without retesting.
- 3) The shipyards/manufacturers have to document at least once a year that the welder has produced acceptable welds in accordance with construction quality standards and Society's requirements in the welding positions, type of welds and backing conditions covered by its certificate. Which documents are required and how to document the evidences should be in agreement between the Society and the shipyards/manufacturers.

6.2.2 (1/1/2018)

The Society has to verify compliance with the above conditions and sign the maintenance of the welder's qualification certificate.