

# **Advanced Electrophysiology**

**Lesson 3**

12 March 2026

**Patch-clamp recordings**

# Calendar

- **Th 26 February (14:00-16:00):** Frontal lesson (ex-Cla)
- **Th 26 February (16:00-18:00):** Data analysis project (ex-Cla)
- **F 27 February (14:00-18:00):** Acute brain slice preparation (Room 309, Building Q)
- **Th 5 March (14:00-16:00):** Frontal lesson (ex-Cla)
- **Th 5 March (16:00-18:00):** Data analysis project (ex-Cla; Bring a laptop!)
- **Th 12 March (14:00-16:00):** Frontal lesson (ex-Cla)
- **Th 12 March (16:00-18:00):** Data analysis project (ex-Cla; Bring a laptop!)
- **F 13 March (14:00-18:00):** Patch-clamp (group 1; Room 309, Building Q)
- **Th 19 March (14:00-18:00):** Patch-clamp (group 2; Room 309, Building Q)
- **F 20 March (14:00-18:00):** Patch-clamp (group 3; Room 309, Building Q)

# Patch-clamp recordings

## Learning objective:

To understand why patch-clamp recordings are so important for neuroscience investigations

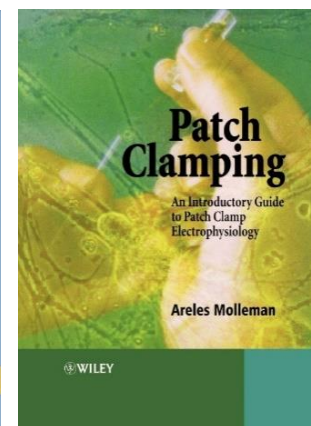
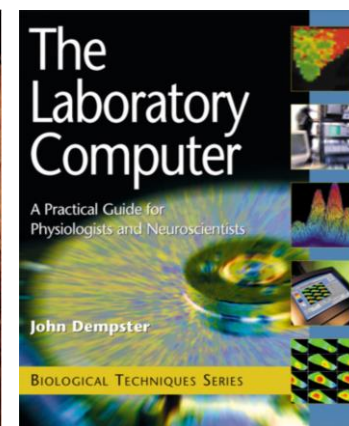
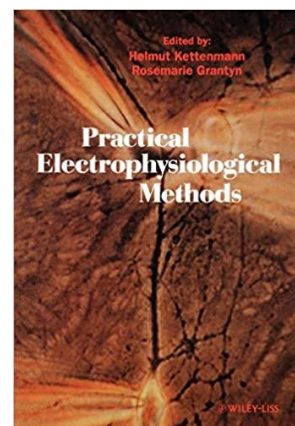
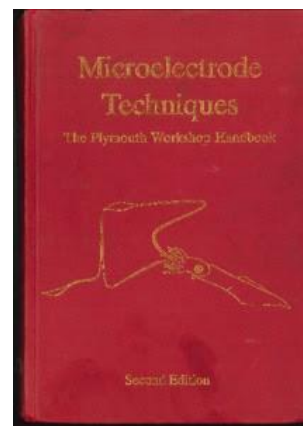
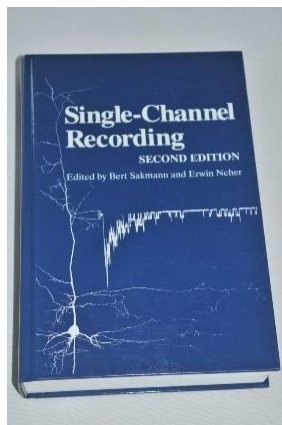
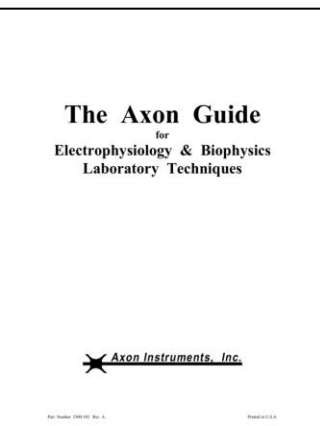

# Outline

**1. A bit of history**

**2. Patch-clamp configurations**

**3. Electronic aspects**

# Outline

**1. A bit of history**

**2. Patch-clamp configurations**

**3. Electronic aspects**

# The 'inventors' of the patch-clamp



Erwin Neher



Bert Sakmann

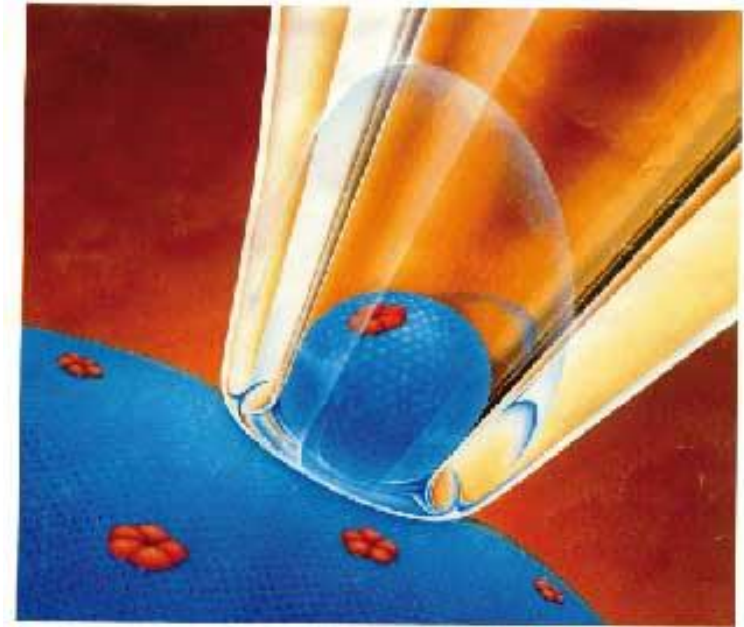

Nobel Prize in Physiology or  
Medicine 1991

"for their discoveries concerning the  
function of single ion channel in cells"

Inventors of the **patch-clamp technique** which for the first time allowed  
for direct recording of the current flowing through a single ion channels

# 'Pre-patch-clamp' single cell electrophysiology

The Nobel Prize in Physiology  
or Medicine 1963

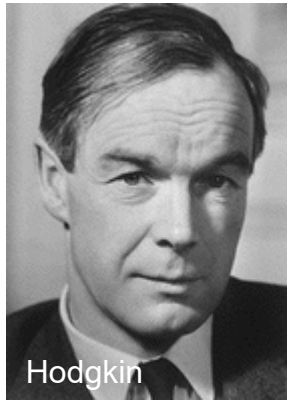

Hodgkin

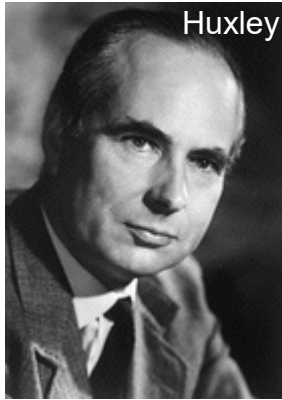

Huxley

From 1939 to 1952, with a 5-year break due to the war, Hodgkin and Huxley, exploiting the work of Young (who found the best way to insert electrodes into the squid axon), gave an elegant and (still) correct explanation of the AP without ever mentioning the word channel. The concept of channel gained acceptance from the early 1970s thanks to the development of the patch-clamp technique (Neher and Sackman).

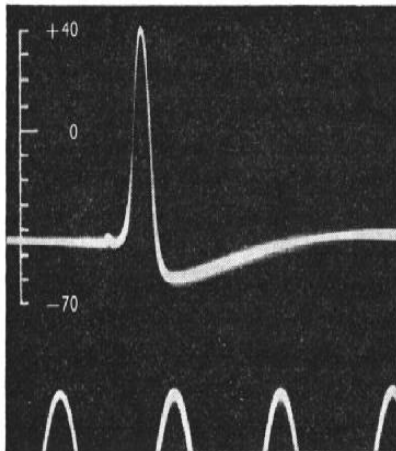
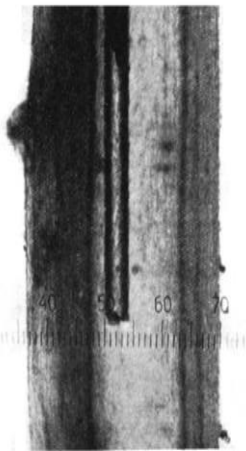

The first AP recording

Why the axon of the squid?

**Because it is giant, the axon  
not the squid**

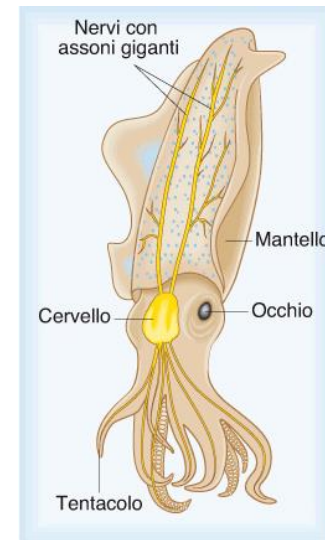

# 'Pre-patch-clamp' single cell electrophysiology

Much of the pioneering research on **quantal synaptic transmission** was conducted in the **frog neuromuscular junction** by **Bernard Katz** and collaborators at UCL in the **1950-1960s**.

Synaptic transmission either does not occur or if it does occur it does so as a multiple of an indivisible basic unit (the quantum)

$$\text{Synaptic strength} = N * P_r * q$$

**N** = number of release sites

**P<sub>r</sub>** = release probability

**q** = quantal size (amplitude of 1 quantum, i.e. of 1 mEPP)

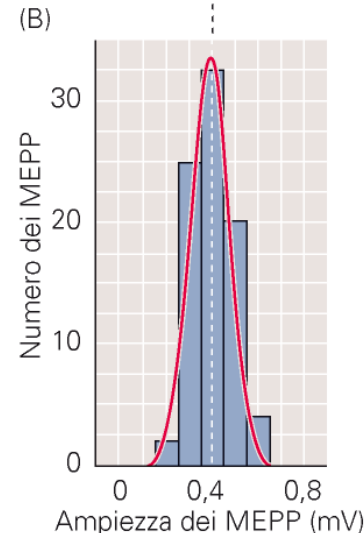
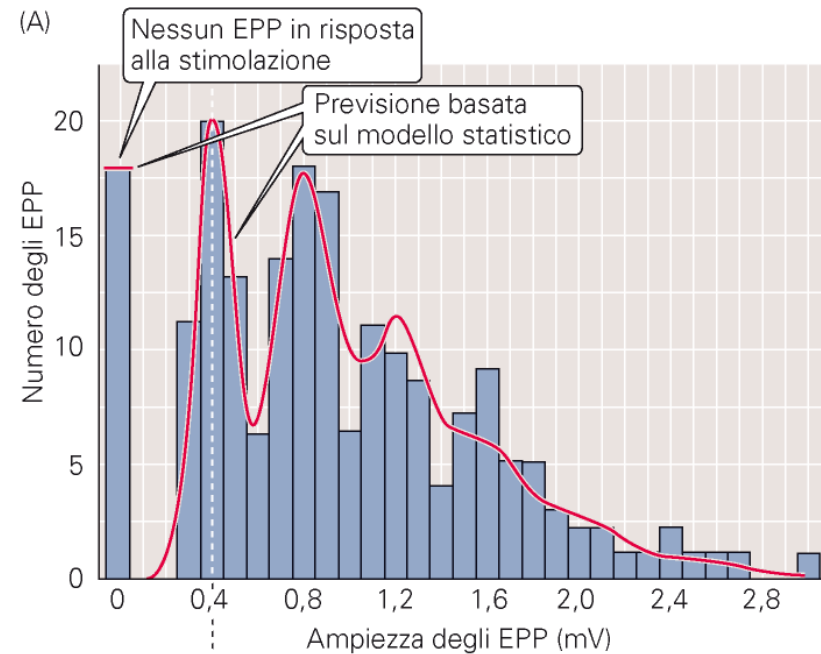

# Sharp microelectrodes

Much of the pioneering research on **quantal synaptic transmission** was conducted in the **frog neuromuscular junction** by **Bernard Katz** and collaborators at UCL in the **1950-1960s**.

**Neuromuscular junction:** highly specialized synapse that convey a potent electrical signal to a very large post-synaptic cell.

The size of the end-plate current typically reaches 100 nA, roughly 3 to 4 orders of magnitude larger than synaptic currents at small central mammalian synapses

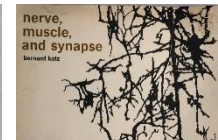
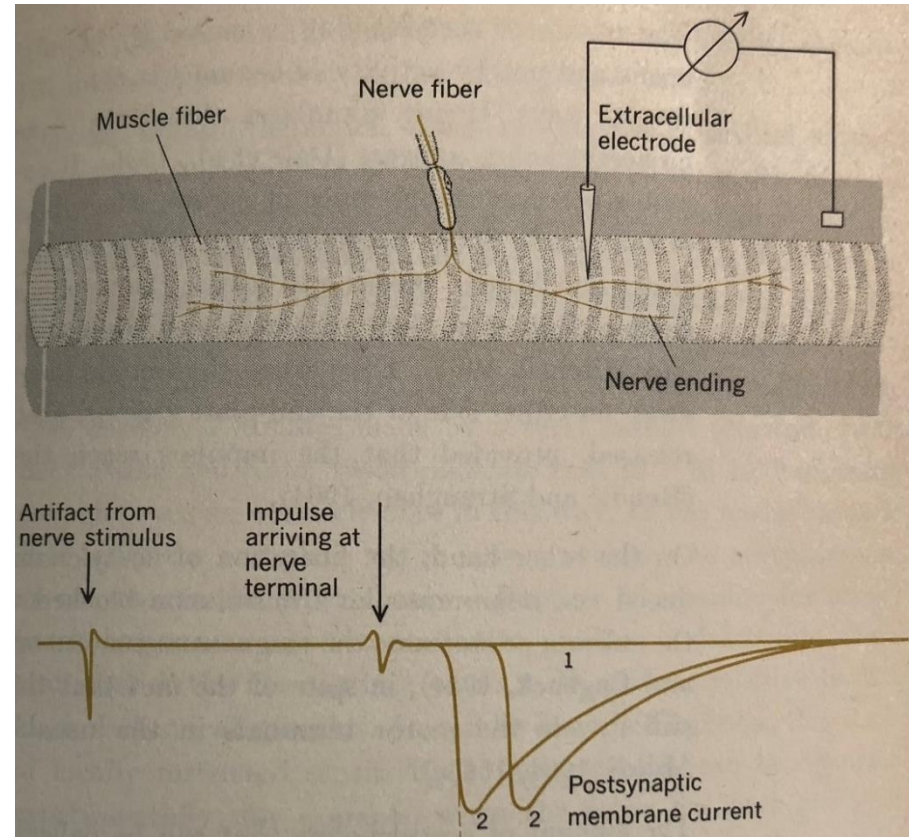

## nerve, muscle, and synapse

Copyright © 1966 by McGraw-Hill, Inc. All Rights Reserved. Printed in the United States of America. This book, or parts thereof, may not be reproduced in any form without permission of the publishers.

Library of Congress Catalog Card Number 66-14815

1617 MUMU 7654

ISBN 07-033383-1

# Sharp microelectrodes vs. patch-clamp electrodes

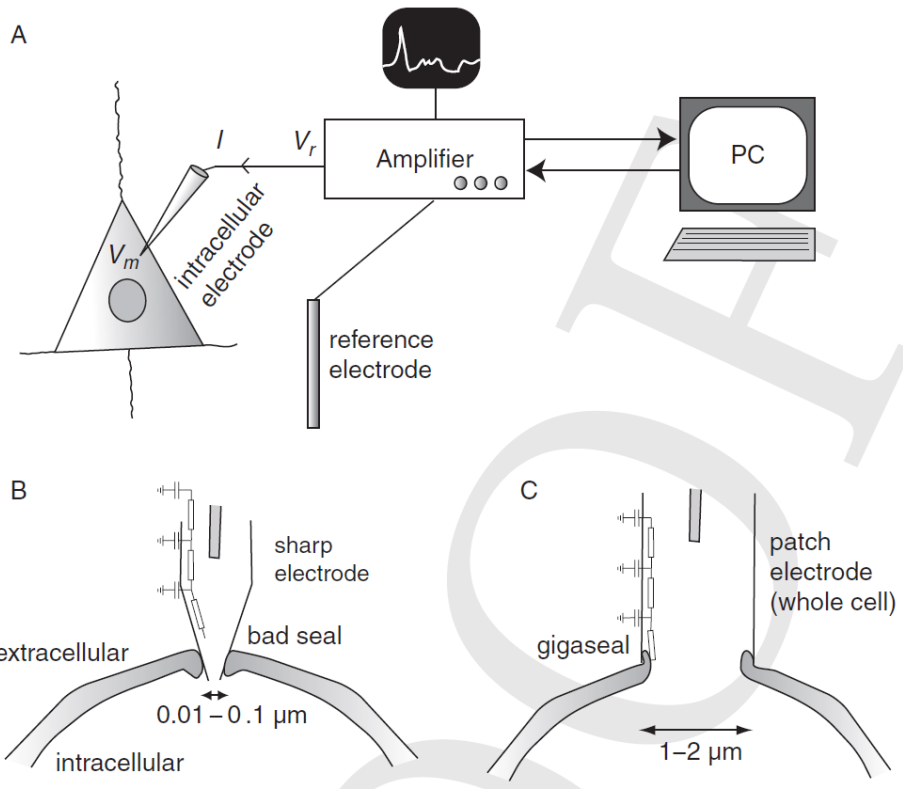

Patch-clamp electrode

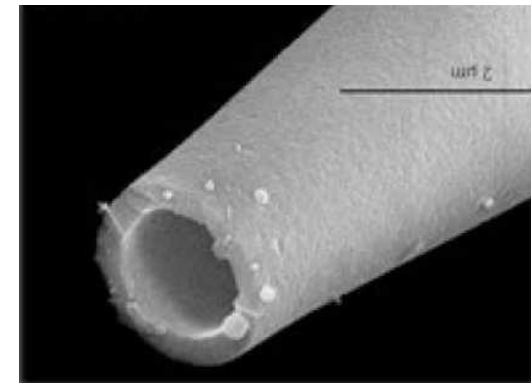

	Sharp	Patch
<b>Tip geometry</b>	Thin	wide
<b>Resistance</b>	High (25-125 MΩ)	Low (<20 MΩ)
<b>Dialysis</b>	No	Yes
<b>Seal</b>	Bad (no seal)	Good (Giga Ω)
<b>Noise</b>	High	Low

# Outline

**1. A bit of history**

**2. Patch-clamp configurations**

**3. Electronic aspects**

# Patch-clamp methods

(Loo

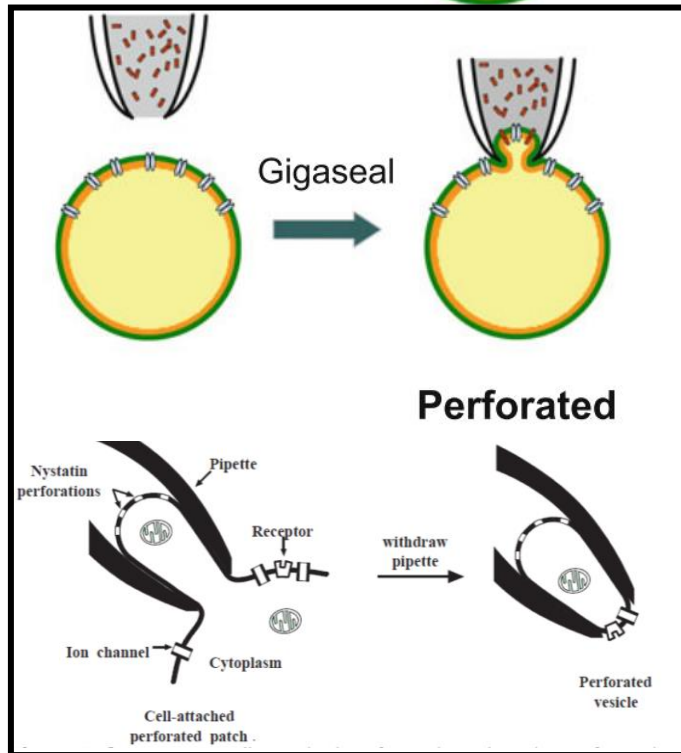
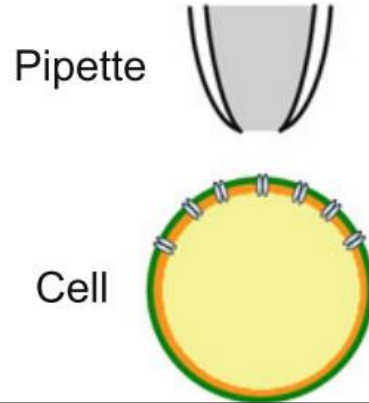

# Perforated-patch configuration

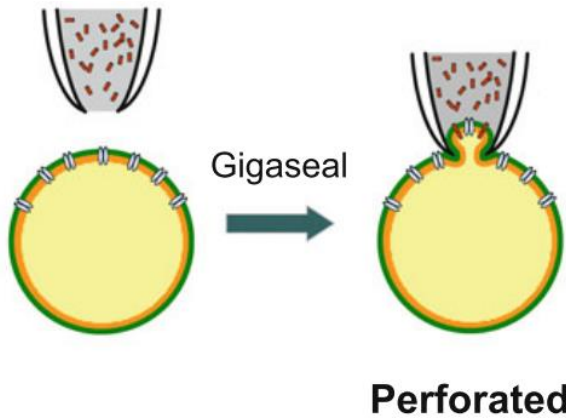

Gramicidin = impermeable to  $\text{Cl}^-$

$$E_{\text{eq}} = \frac{RT}{zF} \ln \frac{[\text{Cl}^-]_o}{[\text{Cl}^-]_i}$$

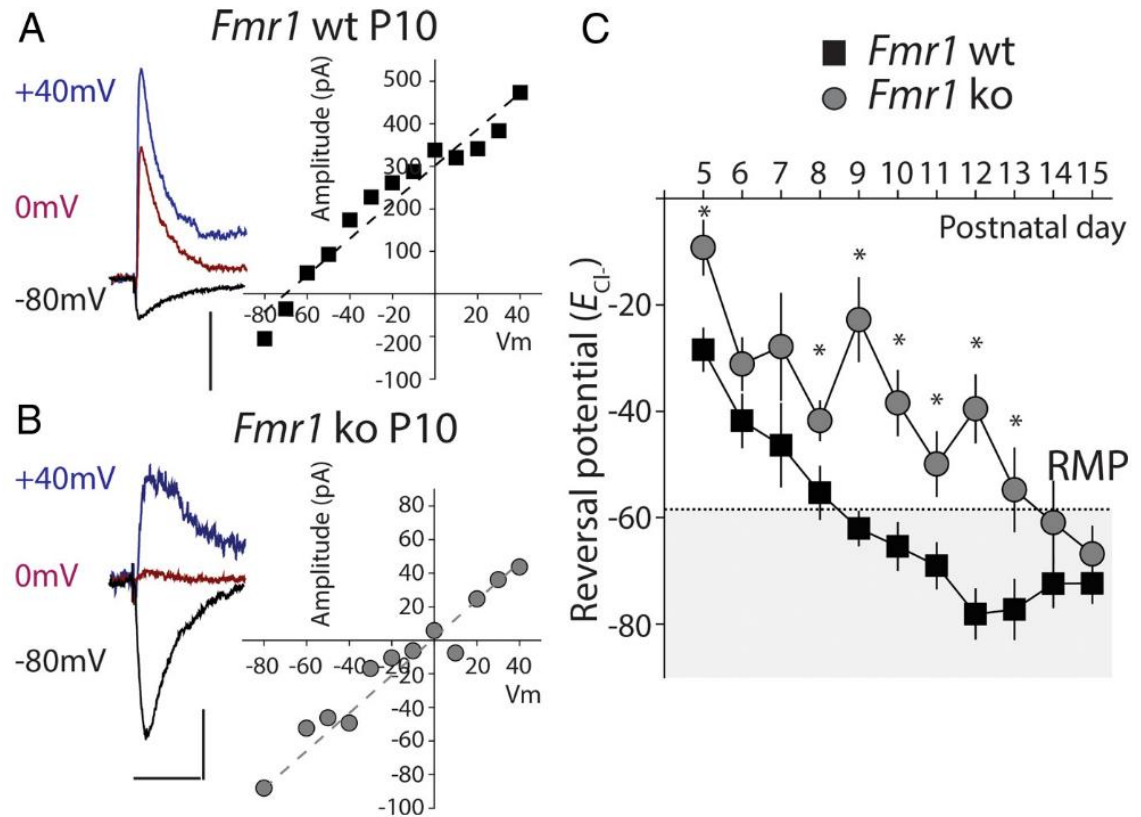

**Figure 1.**  $E_{\text{Cl}^-}$  remains depolarized in *Fmr1* ko mice during cortical development. **A**, Representative example of a perforated patch-clamp recording from a layer IV neuron in the somatosensory cortex of a P10 *Fmr1* wt mouse. Recordings were made at several hold potentials and the  $E_{\text{Cl}^-}$  calculated from the linear fit of the current–voltage relationship. GABA responses shown at  $-80$ ,  $0$ , and  $+40$  mV were evoked by extracellular stimulation in the presence of glutamate blockers D-APV ( $50 \mu\text{M}$ ) and CNQX ( $10 \mu\text{M}$ ). Calibration for current traces: 50 ms, 200 pA. **B**, Representative recording from *Fmr1* ko at P10 and current–voltage relationship of GABA-mediated currents.  $E_{\text{Cl}^-}$  is significantly more depolarized at this age in recordings from *Fmr1* ko mice. Calibration for current traces: 50 ms, 50 pA. **C**, Grouped data from all recordings. The average  $E_{\text{Cl}^-}$  calculated from each individual recording is plotted against the age of the mouse (postnatal day). The RMP measured at P10 is denoted by the dashed line and shaded area represents points at which GABA would have a mature hyperpolarizing response. \* $p < 0.05$  (P5: wt,  $n = 13$ ; ko  $n = 4$ . P6: wt,  $n =$

# Loose-patch and cell-attached configuration

In common: **extracellular recordings of single cell activity**

**Differences:** loose vs. tight contact

of a glass micropipette onto the cell membrane

( $R_{\text{seal}} = \text{M}\Omega$  vs.  $\text{G}\Omega$ )

**Loose-patch pro:** less invasive

**Cell-attached pro:** more sensitive

**For both configurations:**

- **Pros:** easy (high success rate),  
no wash-out of ions and metabolites
- **Cons:** no control on  $V_m$   
no possibility to use intracellular drugs

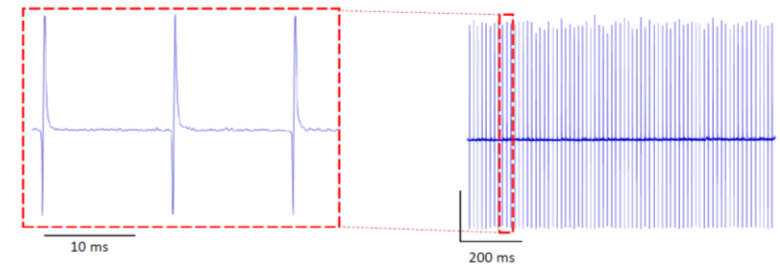
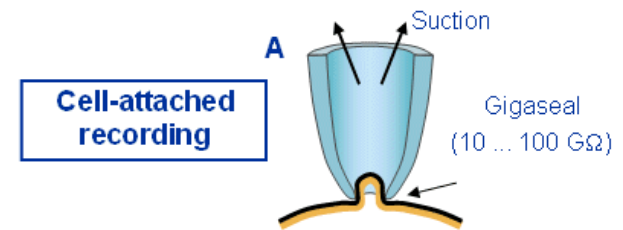
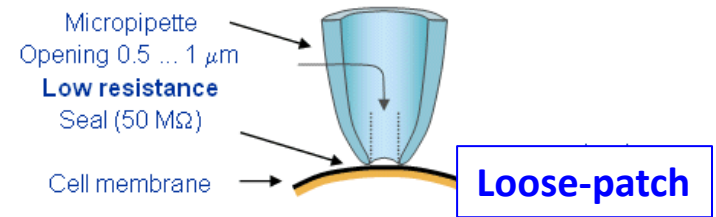

**Both are suitable for the recording of action potentials from single neurons**

# Whole-cell patch-clamp

**Rupture of the membrane under the pipette without rupture of the giga-seal** to obtain **chemical and electrical access to the cell**

- **Pros:** - control on  $V_m$  (**voltage-clamp**) or current (**current-clamp**)
  - possibility to use intracellular drugs
- **Cons:** - relatively skill-demanding
  - invasive (wash-out of ions and metabolites)

- In **current-clamp** configuration suitable for recording of APs and synaptic potentials (E/IPSPs)
- In **voltage-clamp** configuration suitable for recording **macroscopic** currents (voltage-gated or synaptic; e.g. E/IPSCs), but generally not suitable for single-channel recordings

## 1) Cell-attached

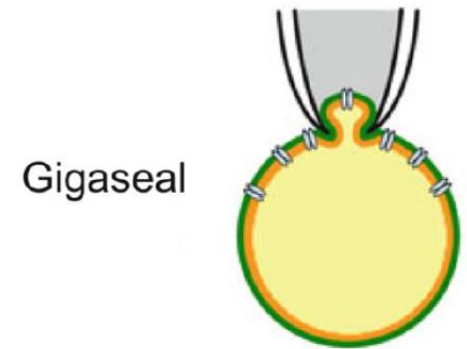

Suction  
Zap

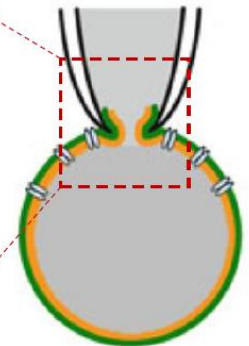

## 2) Whole-cell

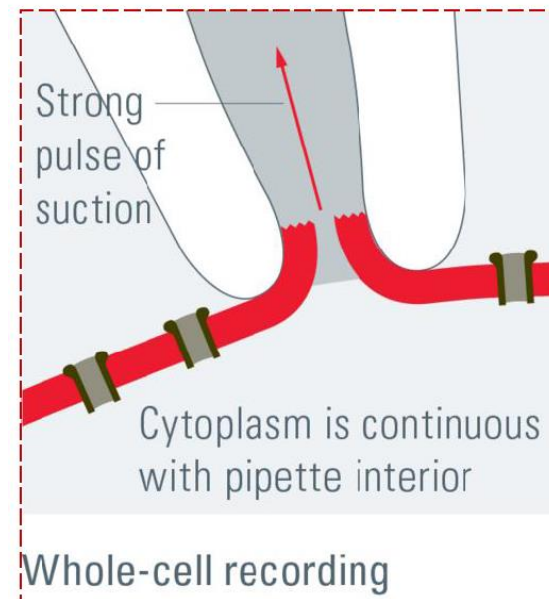

# Outside-out

- Single channel recordings
- Fast application of drugs (e.g. to study activation and inactivation kinetics of channels)

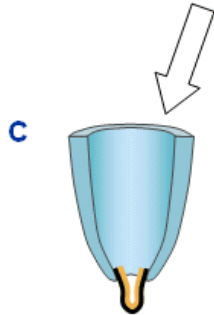
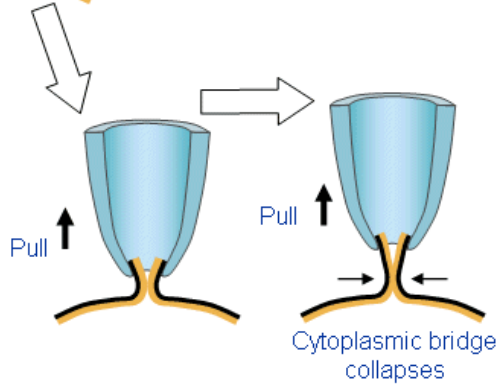
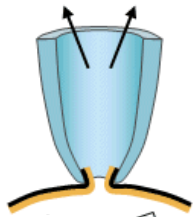

Outside-out patch

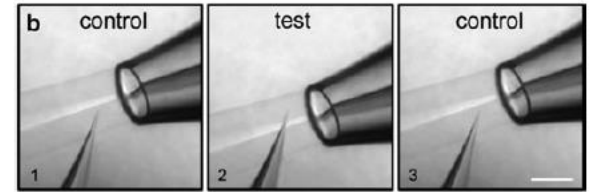
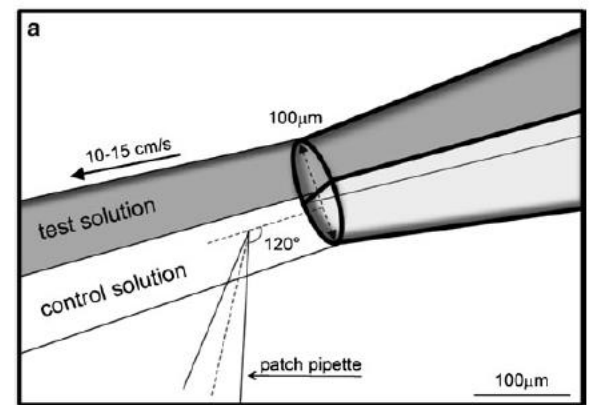
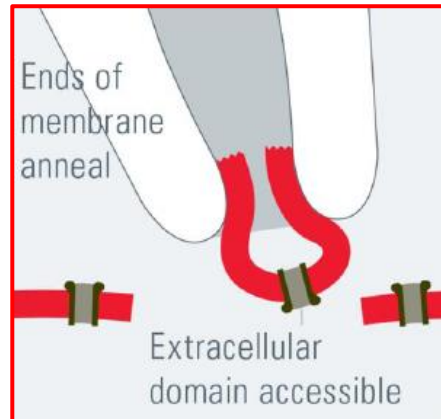

GABA 10 mM, 2 ms

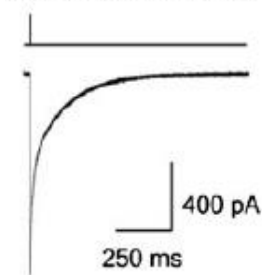

GABA 10 mM, 2 ms

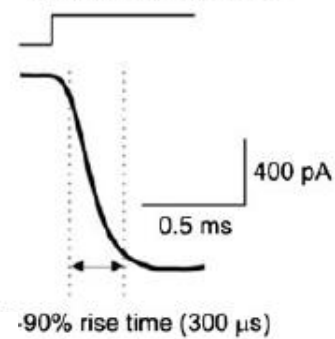

GABA 10 mM, 2 ms

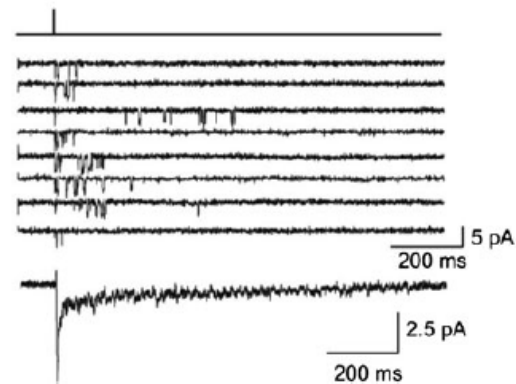

# Outside-out nucleated patches

- **Pro: Perfect space-clamp** (space-clamp is poor in the whole-cell configuration for a neuron with a complex dendritic tree)

- **Con: Lost connectivity**

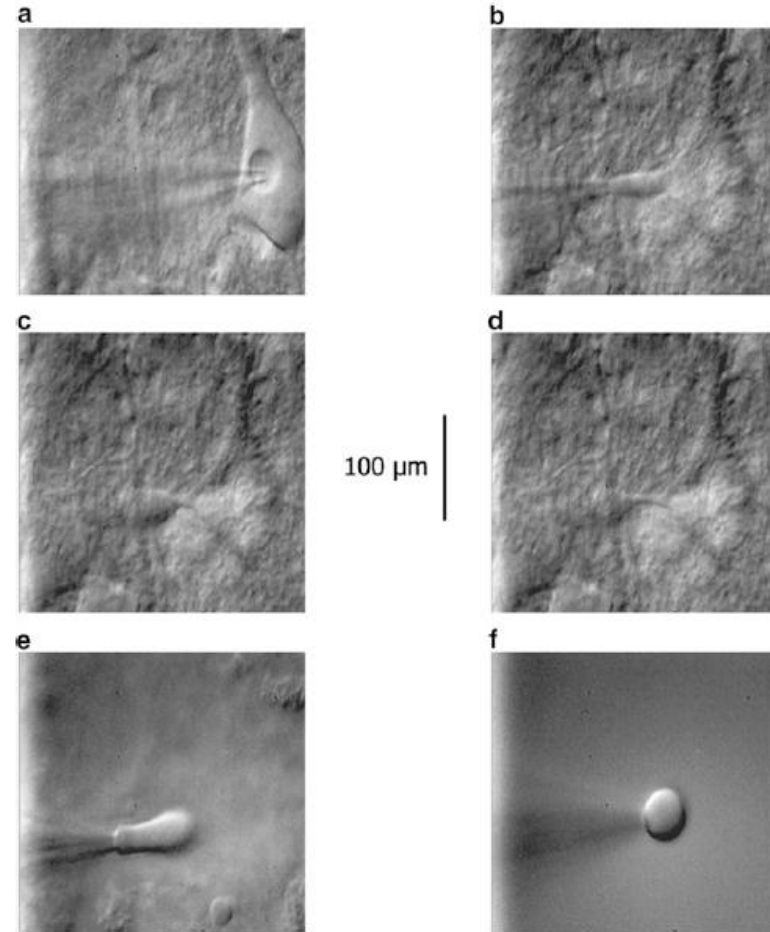
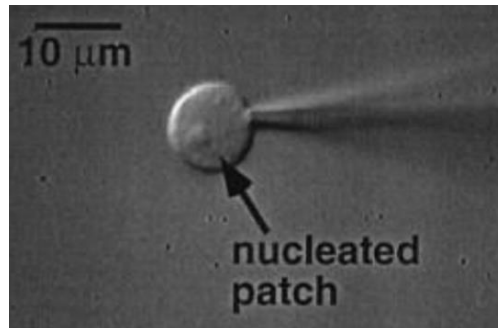
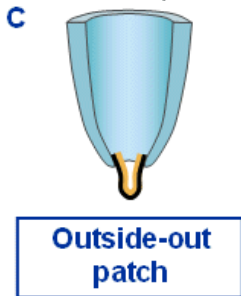
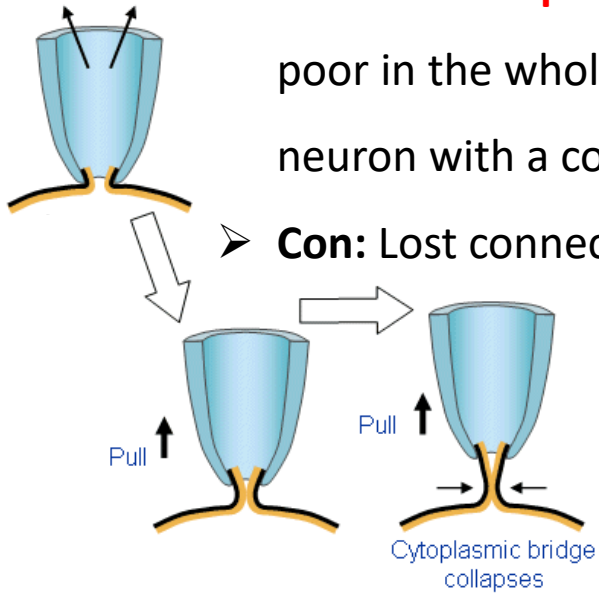

# Inside-out

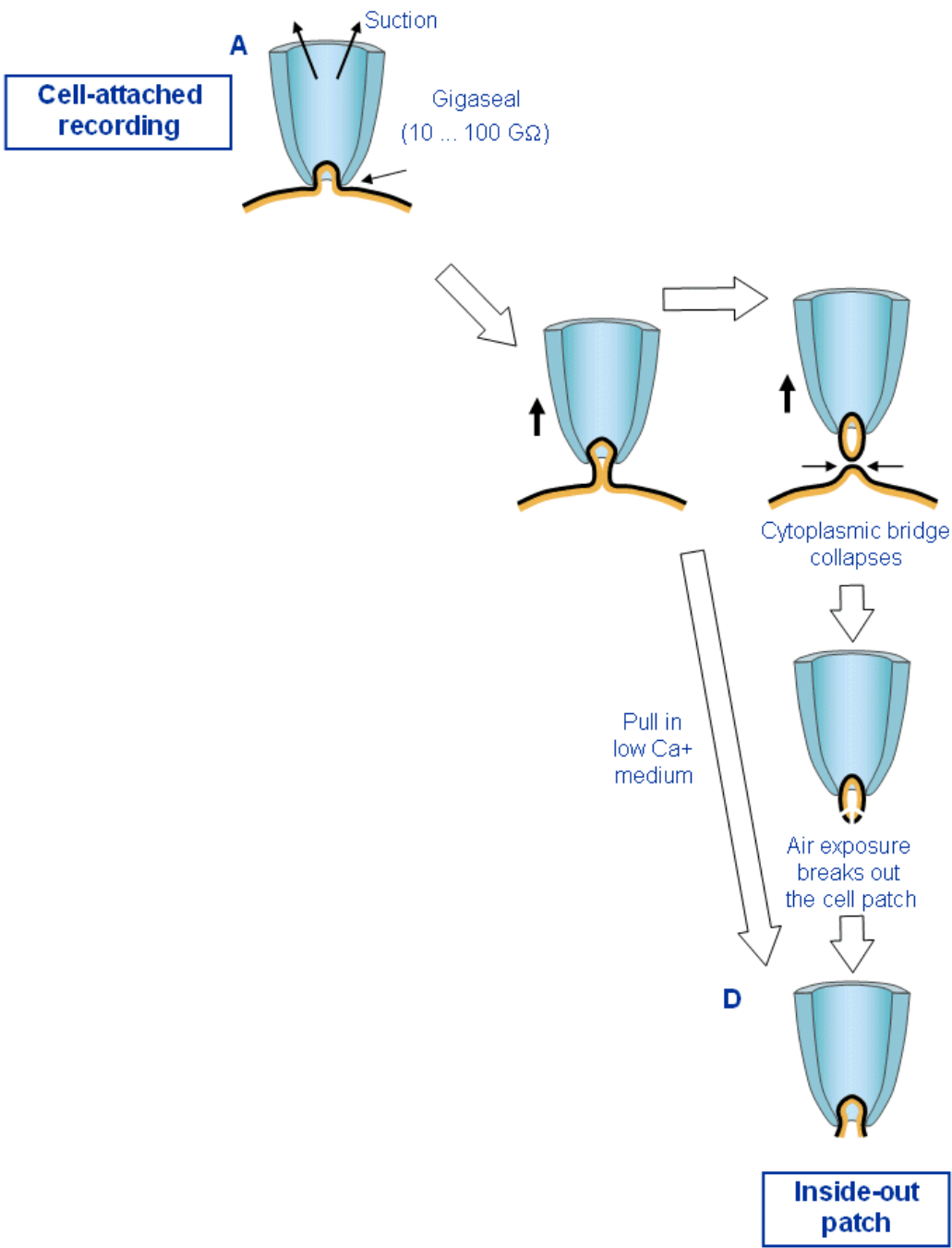

# Outline

**1. A bit of history**

**2. Patch-clamp configurations**

**3. Electronic aspects**

# Current-clamp vs. voltage-clamp

In **current-clamp**, one applies a known constant or time-varying current and measures the change in  $V_m$  caused by the applied current. **This type of experiment is 'more physiological' because it mimics the currents produced by synaptic inputs.**

# Current-clamp vs. **voltage-clamp**

In **voltage-clamp**, one holds constant (= clamps)  $V_m$  and **measures ion channel currents**.

Although voltage-clamp does not mimic a process found in nature, there are 3 reasons to do such an experiment:

- 1) Usually, one has no interest in membrane currents *per se* but in the activity of a (homogeneous) group of ion channels (Conductance ( $G_{\text{macro}}$ ) = number of open ion channel ( $N_{\text{open}}$ ) times their single channel conductance ( $G_i$ )).

By holding  $V_m$  (i.e. the driving-force) constant, one ensures that  $G_{\text{total}}$  is proportional to the recorded macroscopic current ( $i_{\text{macro}}$ )

We measure it (for each  $V_m$ )

$$G_{\text{macro}} = \frac{i_{\text{macro}}}{(V_m - E_{\text{rev}})}$$

(Ohm's (first) law)

We hold it constant (or we change it step-wise as we please)

We estimate it using the Nernst equation and/or we empirically determine it

# Current-clamp vs. **voltage-clamp**

## Classical AMPAR currents

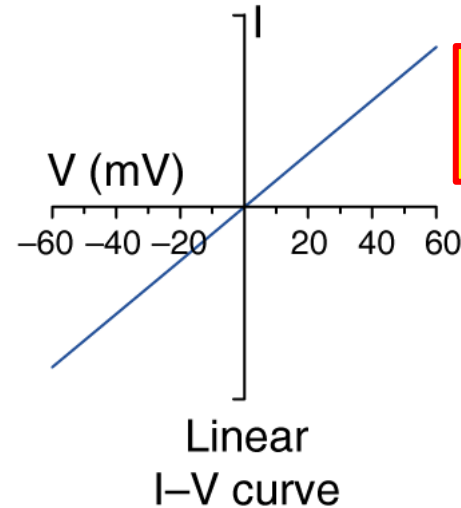
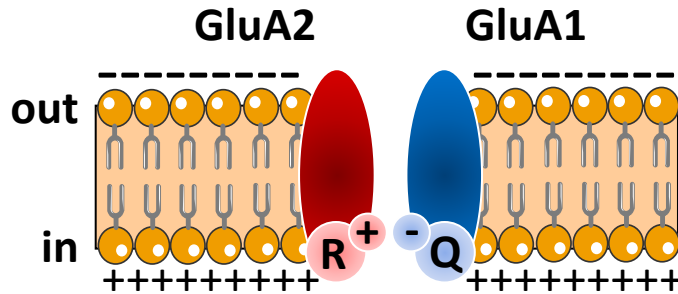

**G = slope of the linear  
(= ohmic) I/V plot**

We measure it (for each  $V_m$ )

$$G_{\text{macro}} = \frac{i_{\text{macro}}}{(V_m - E_{\text{rev}})}$$

**(Ohm's (first) law)**

We hold it constant (or we change it step-wise as we please)

We estimate it using the Nernst equation and/or we empirically determine it

# Current-clamp vs. **voltage-clamp**

In **voltage-clamp**, one holds constant (= clamps)  $V_m$  and **measures ion channel currents**.

Although voltage-clamp does not mimic a process found in nature, there are 3 reasons to do such an experiment:

- 2) If the gating of the channel is **voltage-dependent** (i.e.  $G_i$  itself depends on  $V_m$ ), voltage-clamp offers control over a key variable that determines opening and closing of the ion channel.

$$G_{\text{macro}} \times \frac{i_{\text{macro}}}{V_m - E_{\text{rev}}}$$

(Ohm's ~~law~~) law)

# Current-clamp vs. **voltage-clamp**

GluA2-lacking AMPAR currents

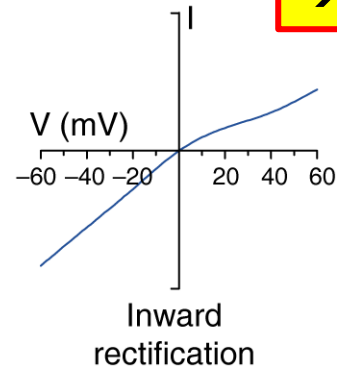
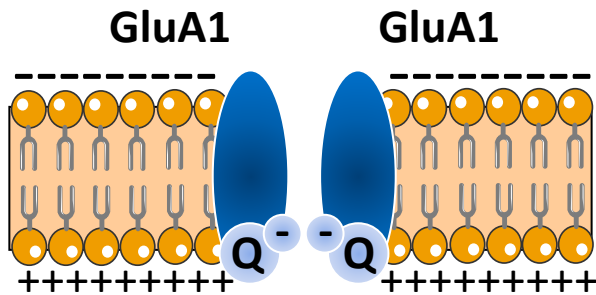

The I/V plot is not linear  
→  $G_i$  is voltage-dependent

Spermine

~~$$G_{\text{macro}} = \frac{i_{\text{macro}}}{V_m - E_{\text{rev}}}$$~~

~~(Ohm's (rest) law)~~

# Current-clamp vs. **voltage-clamp**

In **voltage-clamp**, one holds constant (= clamps)  $V_m$  and **measures ion channel currents**.

Although voltage-clamp does not mimic a process found in nature, there are 3 reasons to do such an experiment:

- 3) **Clamping  $V_m$  eliminates the capacitive current, except for a brief time following a step to a new voltage.**

$$i_T(t) = C \frac{dV_m}{dt}$$

# Voltage-clamp configuration

In **voltage-clamp**, one holds constant (= clamps)  $V_m$  and 'measures ion channel currents'.

**How?**

The voltage-clamp circuit is a negative feedback device designed to monitor  $V_m$  and inject current into the cell to hold  $V_m$  constant  $\longrightarrow$  The amplifier 'knows' the ion channel currents by the current it needs to inject to keep  $V_m$  constant!!!

In the whole-cell patch-clamp configuration, one single pipette is used to simultaneously monitor  $V_m$  and inject current!!!!

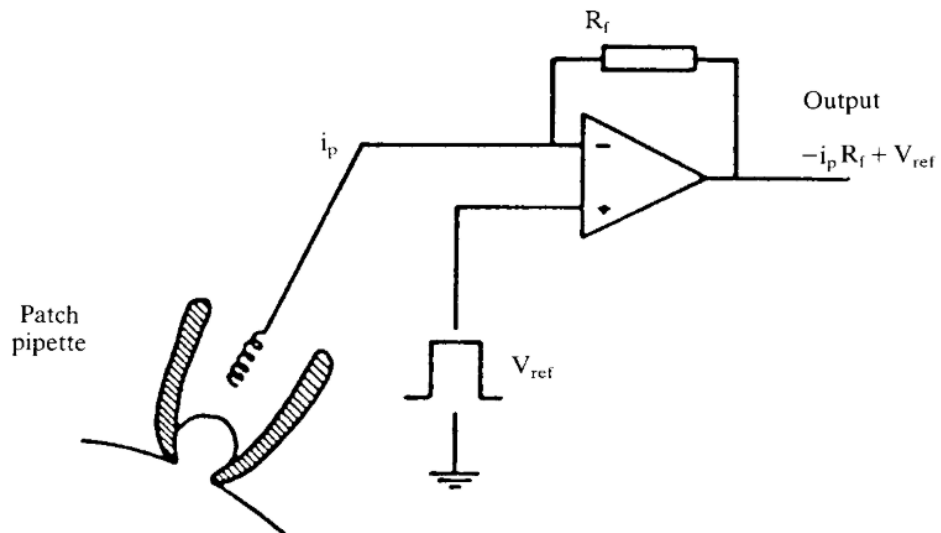

# Voltage-clamp configuration

**Problem of using one single pipette to simultaneously monitor  $V_m$  and inject current:  $V$**  is recorded by the amplifier at the top of the pipette ( $V_r$  rather than  $V_m$ ); this is the sum of  $V_m$  (which we wish to control) and the  $\Delta V$  drop across the pipette resistance ( $\Delta V = i R_s$ ).

**To avoid introducing voltage errors:**

- 1)  $R_s$  must be as small as possible (<20 M $\Omega$ , **this is possible only with patch-clamp electrodes!!!**);  $R_s$  must also be as constant as possible;
- 2) Recorded currents must be as small as possible (tens of pA range): **the amplifier does not measure directly ion channel currents but the current it needs to inject to keep  $V_m$  constant!!!**

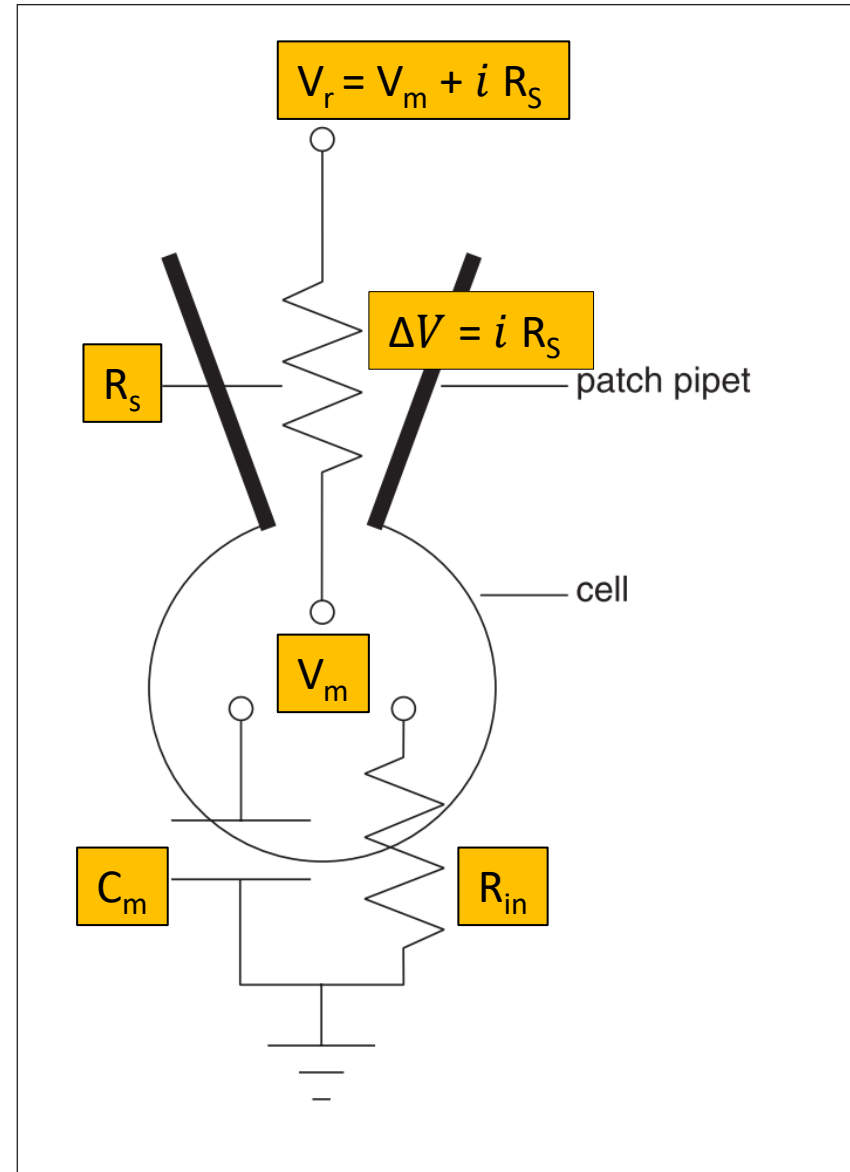

# The formation of a giga-seal

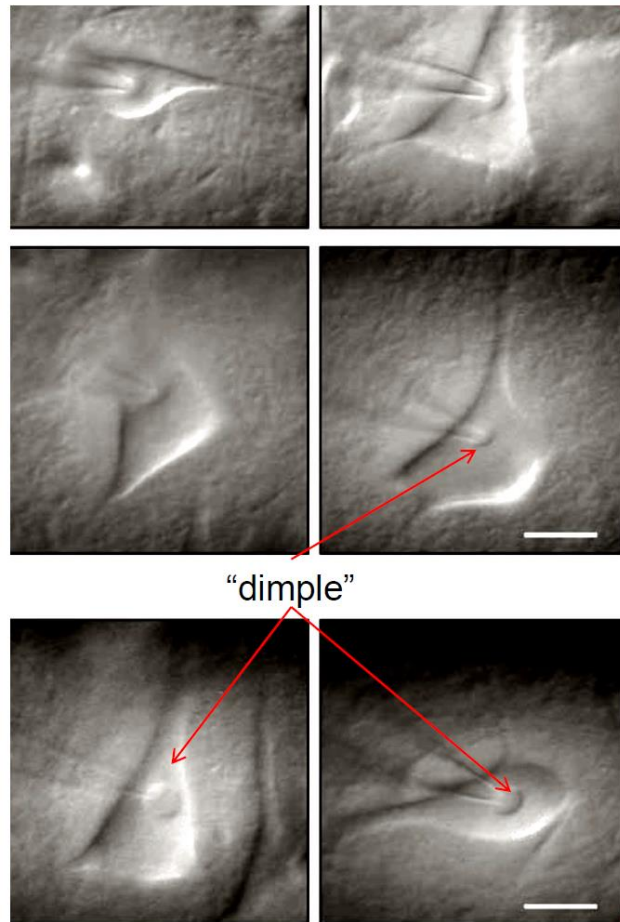

"dimple"

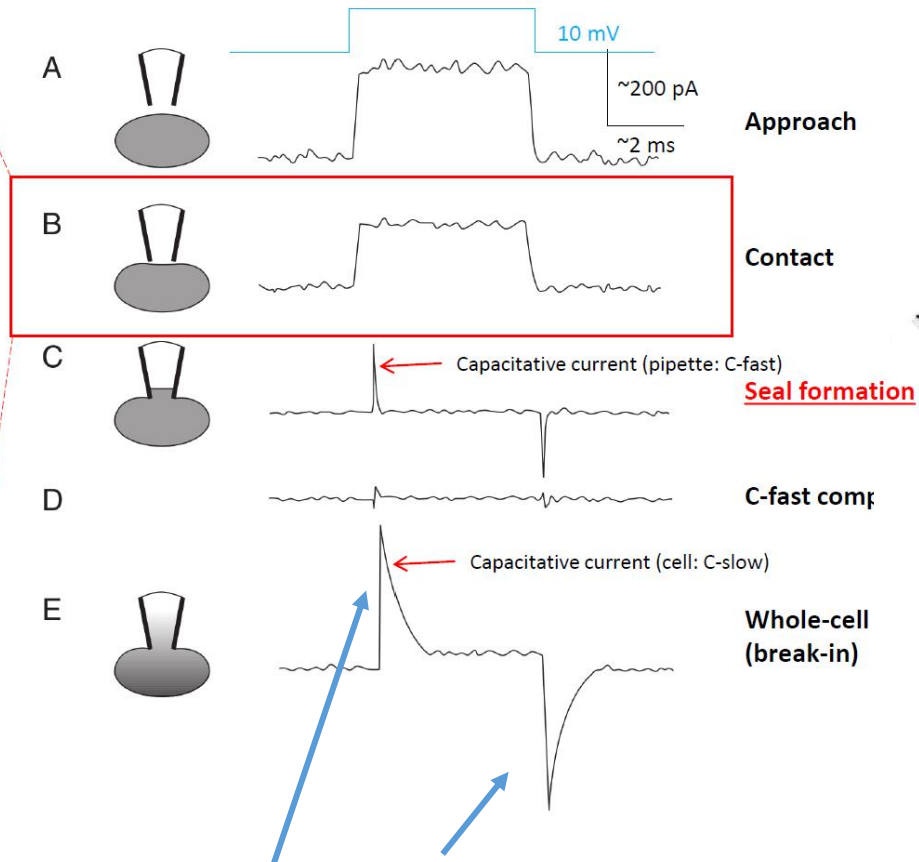

3) Clamping  $V_m$  eliminates the capacitive current, except for a brief time following a step to a new voltage.

# Voltage-clamp configuration

3) Clamping  $V_m$  eliminates the capacitive current, except for a brief time following a step to a new voltage.

If  $R_s \ll R_{in}$

$$R_s = \frac{V_{step}}{i_{in}}$$

$$C_m = \frac{\tau}{R_s}$$

$$R_{in} = \frac{V_{step}}{i_{ss}}$$

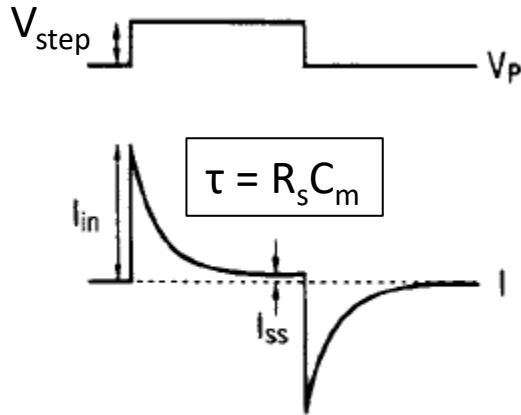

$$V_{step} = R_s \frac{dQ}{dt} + \frac{Q}{C_m}$$

$$Q = V_{step} C_m (1 - e^{-\frac{t}{R_s C_m}})$$

$$i = \frac{dQ}{dt} = \frac{V_{step}}{R_s} e^{-\frac{t}{R_s C_m}}$$

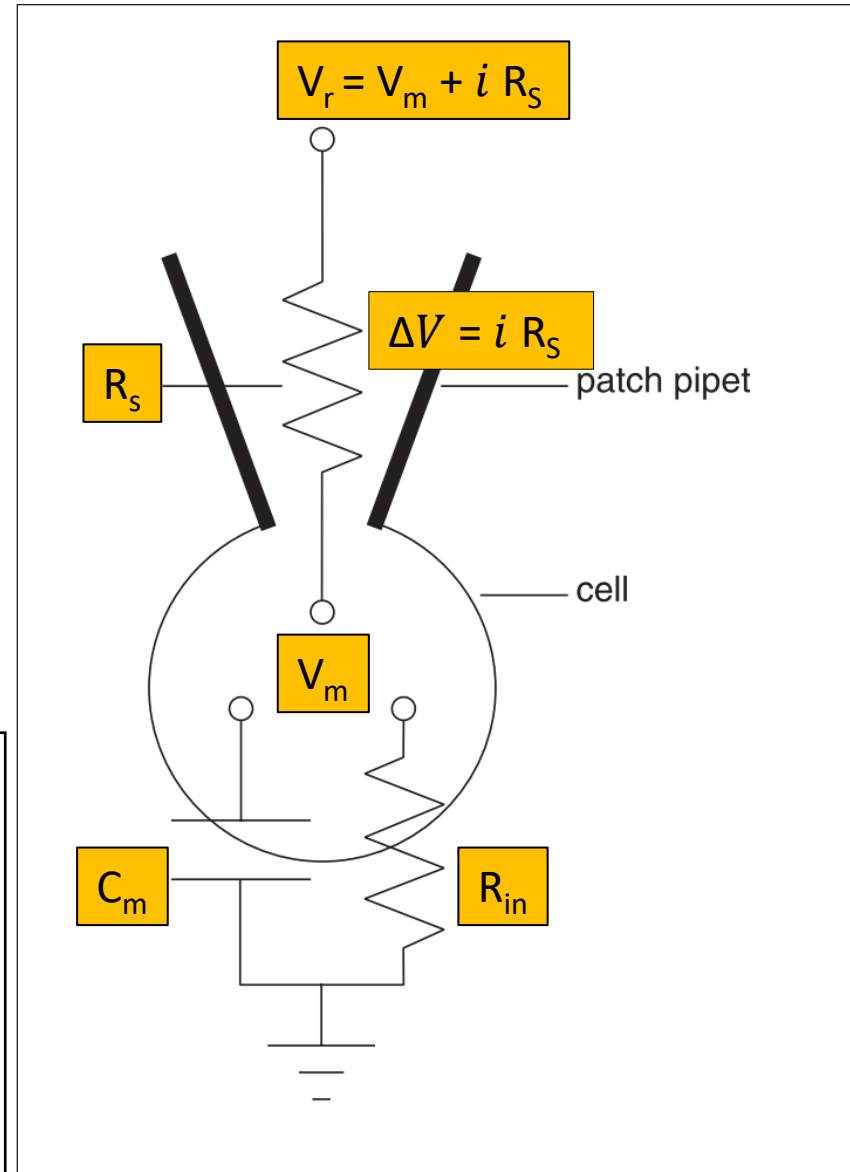

# Learning objectives

1. To know the major differences between sharp and patch-clamp electrodes
2. To know the major patch-clamp configurations and what they are good for
3. To understand the differences between current-clamp and voltage-clamp
4. To understand advantages (and limitations) of the whole-cell voltage clamp configuration