

# Camere a ionizzazione

## Principi e funzionamento

# Generic detector: energy to charge conversion

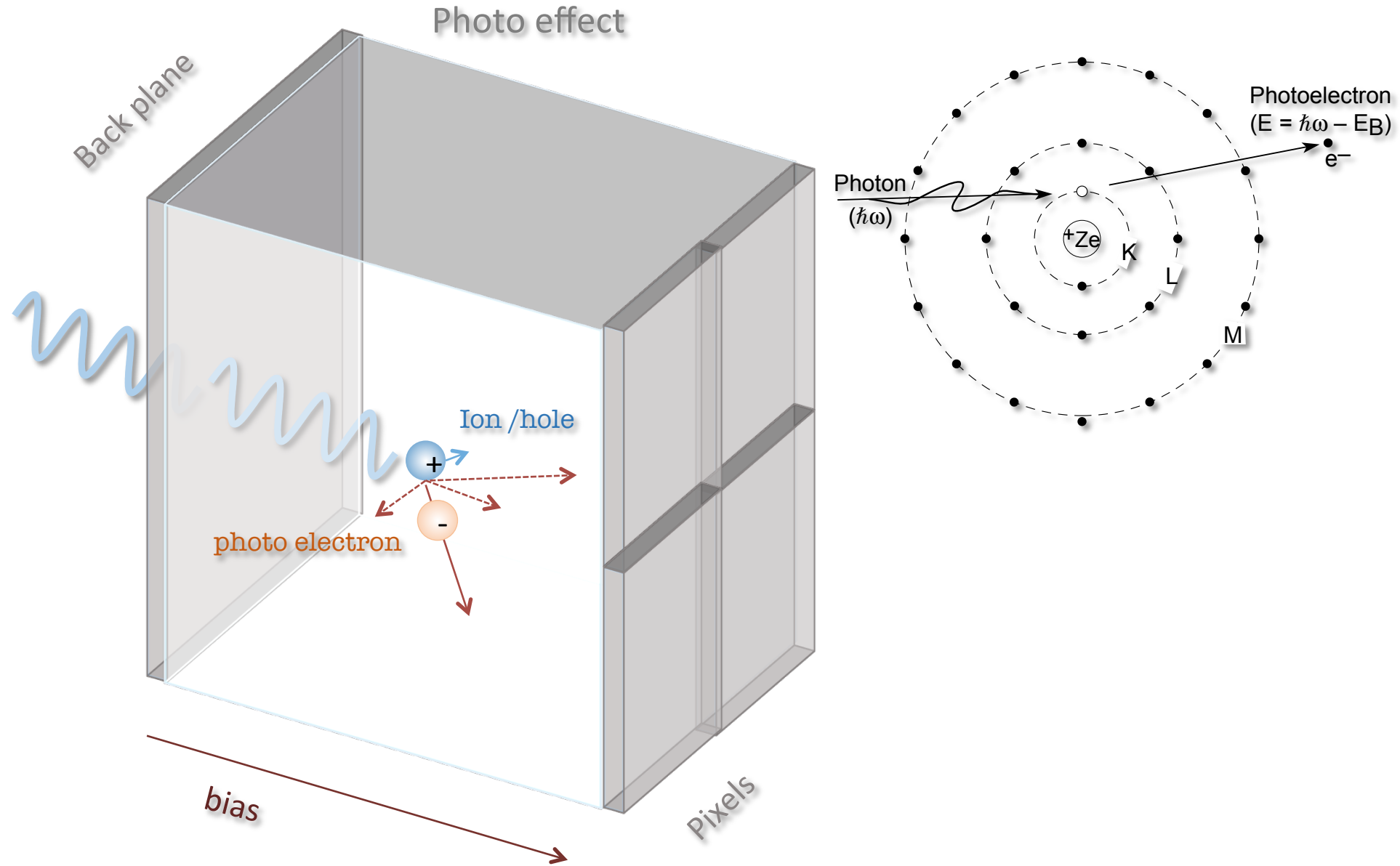

# Generic detector working principle

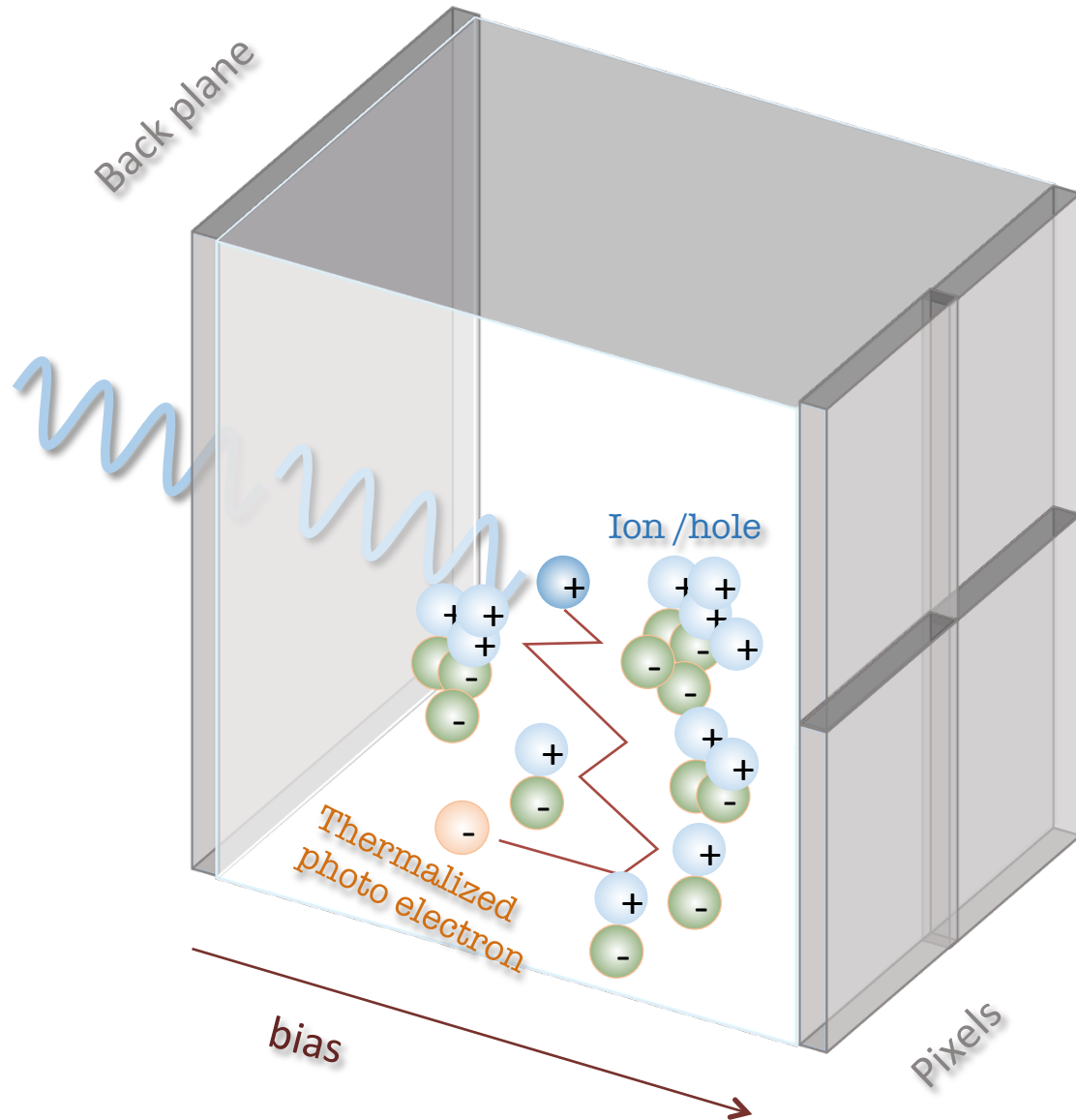

Electron collision induced ionization

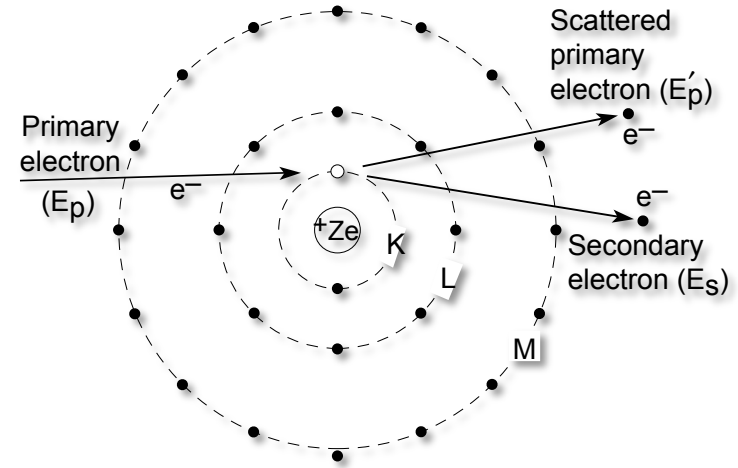

$$E_p - E_B > W_{ion}$$

$W_{ion}$  is at least the energy required to generate an electron ion/hole pair

# Charge collection and collection efficiency

$$Q = \frac{E_\gamma}{w_{ion}} \cdot e \cdot \epsilon_c$$

Gas	Density $\rho$ [g/cm <sup>3</sup> ]	$I_0$ [eV]	$W$ [eV]	$n_p$ [cm <sup>-1</sup> ]	$n_T$ [cm <sup>-1</sup> ]
H <sub>2</sub>	$8.99 \cdot 10^{-5}$	15.4	37	5.2	9.2
He	$1.78 \cdot 10^{-4}$	24.6	41	5.9	7.8
N <sub>2</sub>	$1.25 \cdot 10^{-3}$	15.5	35	10	56
O <sub>2</sub>	$1.43 \cdot 10^{-3}$	12.2	31	22	73
Ne	$9.00 \cdot 10^{-4}$	21.6	36	12	39
Ar	$1.78 \cdot 10^{-3}$	15.8	26	29	94
Kr	$3.74 \cdot 10^{-3}$	14.0	24	22	192
Xe	$5.89 \cdot 10^{-3}$	12.1	22	44	307
CO <sub>2</sub>	$1.98 \cdot 10^{-3}$	13.7	33	34	91
CH <sub>4</sub>	$7.17 \cdot 10^{-4}$	13.1	28	16	53
C <sub>4</sub> H <sub>10</sub>	$2.67 \cdot 10^{-3}$	10.8	23	46	195

Si

3.6

C (diamond)

15.5

GaAs

~1.0

# Detector working principle

Fluorescence: spatial and temporal impact.

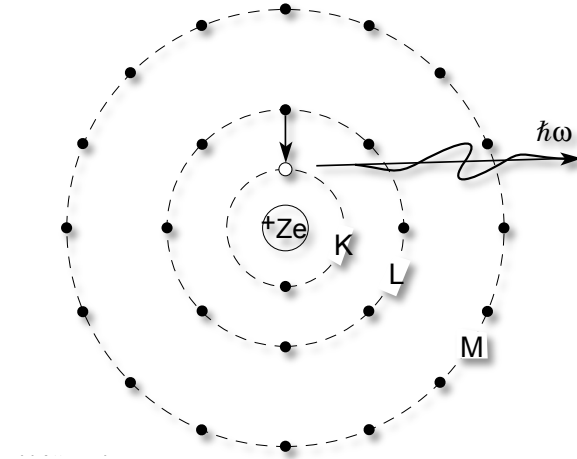
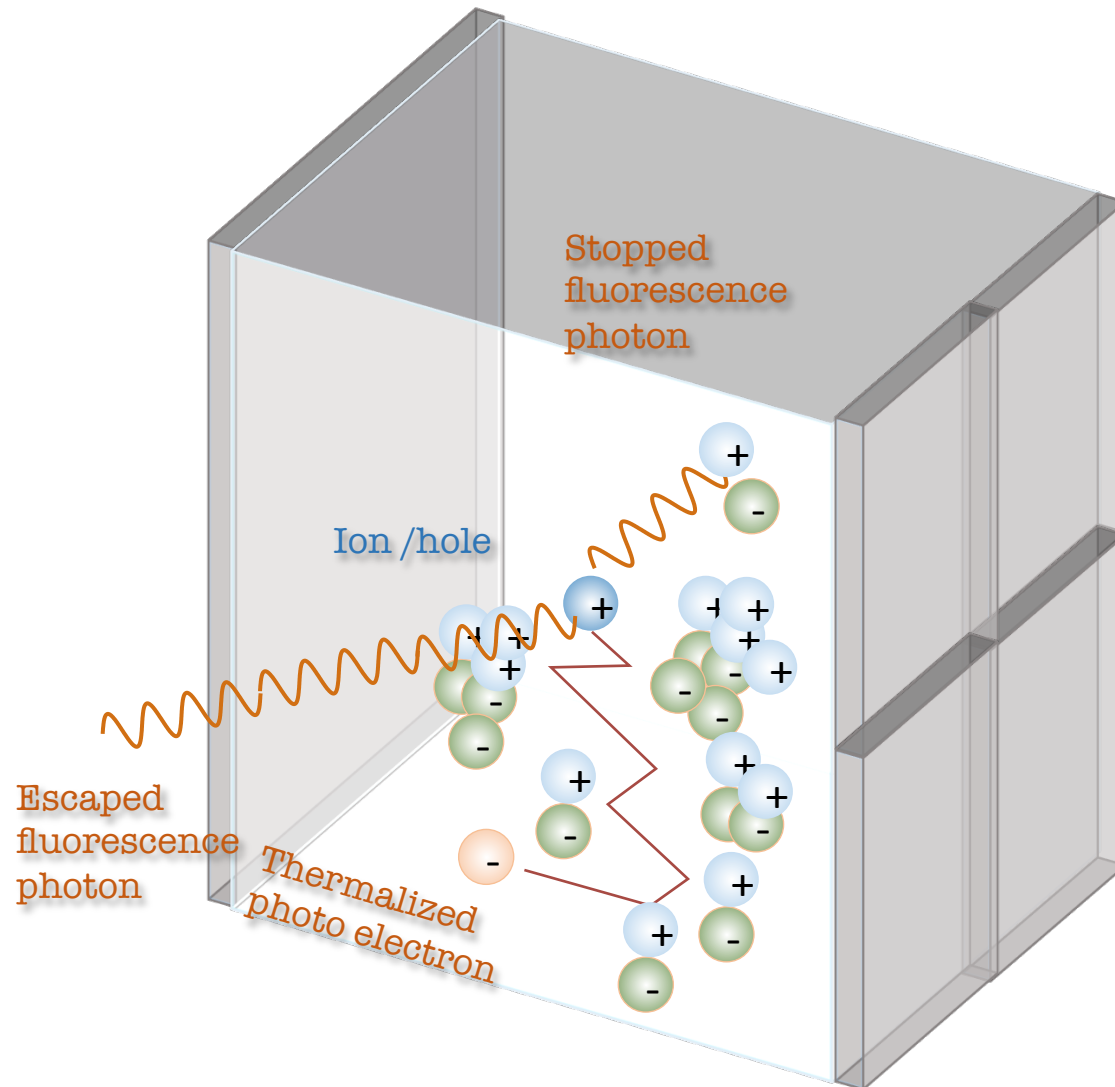

$\hbar \cdot \omega$  is the energy missing once the the fluorescence escapes from the detection volume.

# Detector working principle

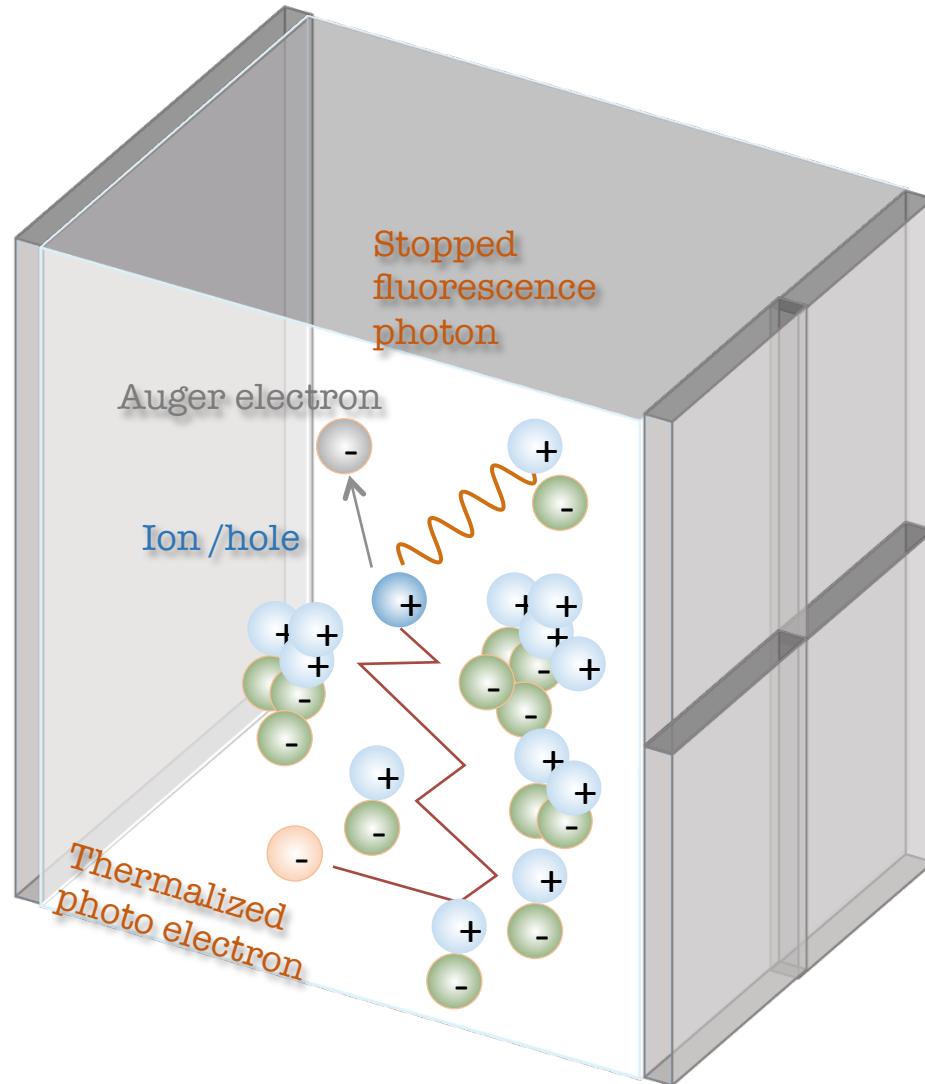

## Auger effect

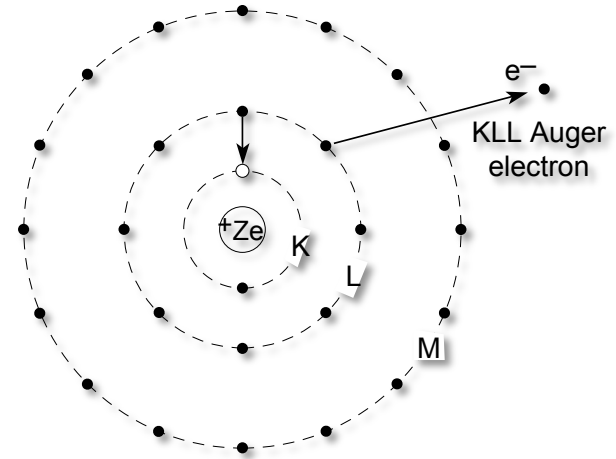

$$E_{Auger} = E_K - 2 \cdot E_L$$

For Auger effect on the L shell. Normally low energy electrons with limited range .

# IONIZATION CHAMBER

- The **ionization chamber** is the simplest of all gas-filled radiation detectors, and is widely used for the detection and measurement of certain types of ionizing radiation; X-rays, gamma rays and beta particles. Conventionally, the term "**ionization chamber**" is used exclusively to describe those detectors which collect all the charges created by *direct ionization* within the gas through the application of an electric field.

An ionization chamber is a device that detects **ionizing radiation** by measuring the electric current generated when radiation, such as **alpha particles**, **beta particles**, **gamma rays**, or **X-rays**, ionizes the gas in the chamber and therefore makes it electrically conductive. It contains two electrodes with a variable potential difference between them. The passage of radiation through the chamber ionizes the gas and the ions formed move towards the charged electrodes. The current thus produced, which is amplified in an associated circuitry, is proportional to the radiation intensity. A similar process is used in a **Geiger counter**, which detects and measures radioactivity.

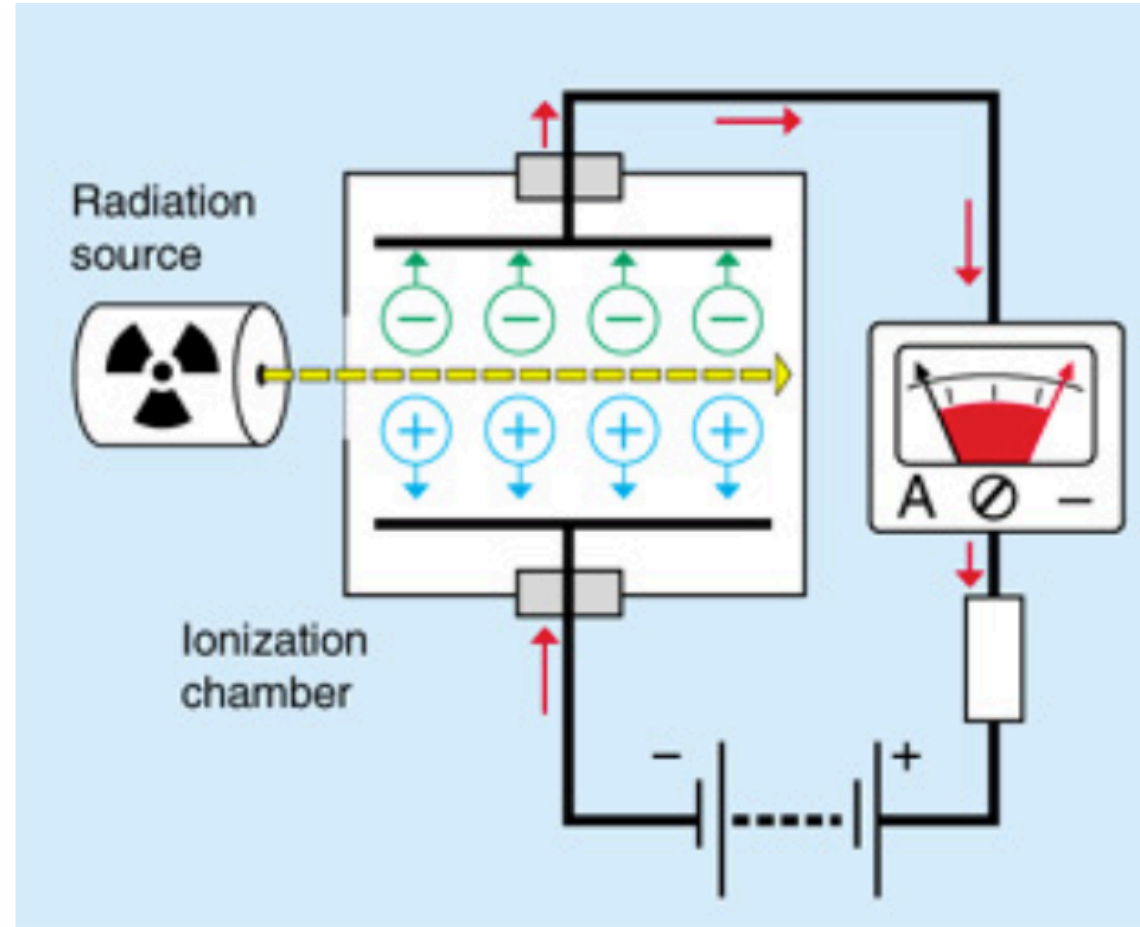

Principle of the ionization chamber. Credit: European Nuclear Society.

# Free Air Ionization Chamber

- The free-air, or standard, ionization chamber is an instrument used in the measurement of the roentgen according to its definition.
- An x-ray beam, originating from a focal spot  $S$ , is defined by the diaphragm  $D$ , and passes centrally between a pair of parallel plates.
- A high-voltage is applied between the plates to collect ions produced in the air between the plates.
- The ionization is measured for a length  $L$  defined by the limiting lines of force to the edges of the collection plate  $C$ .

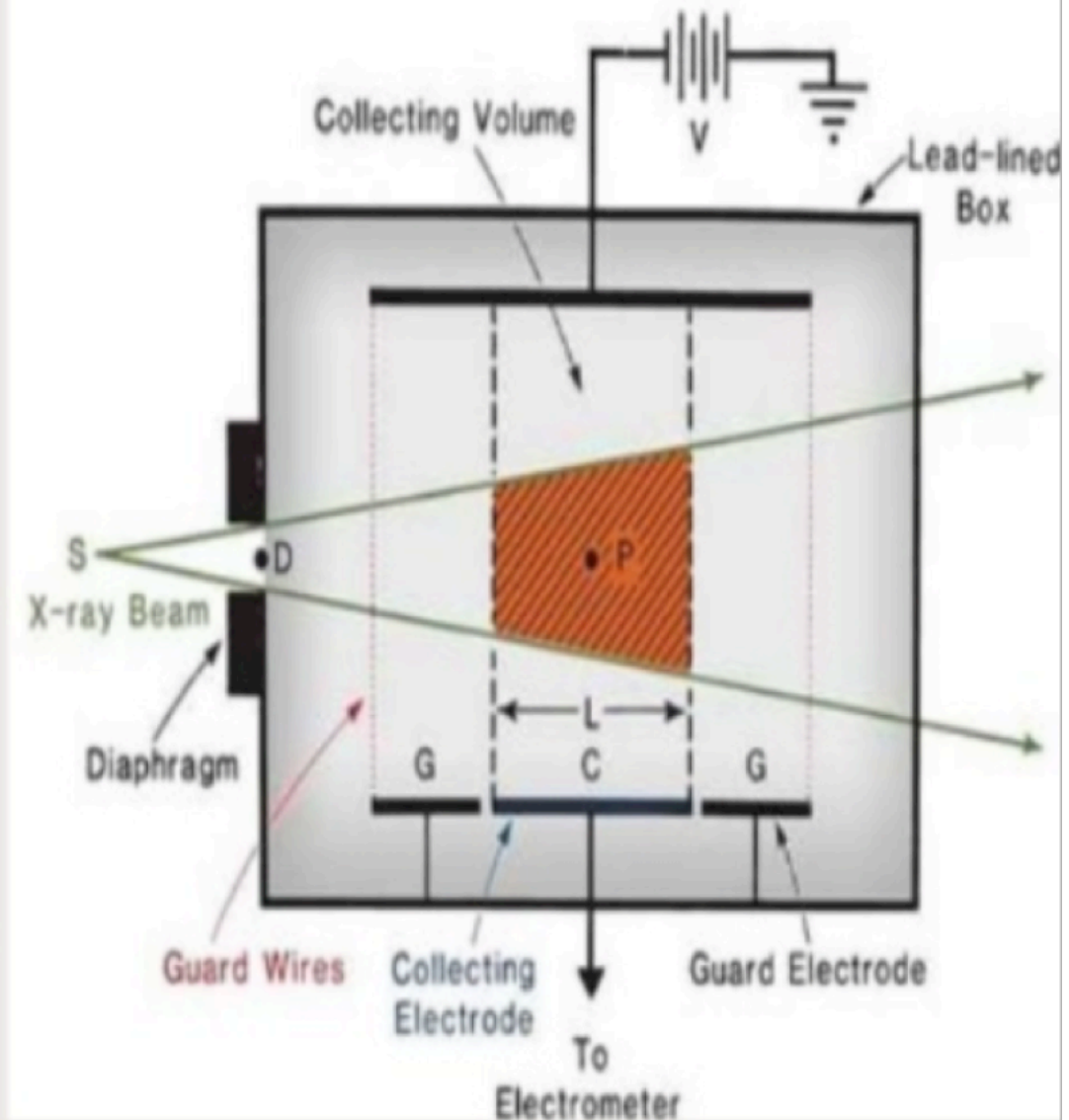

# Saturation curve

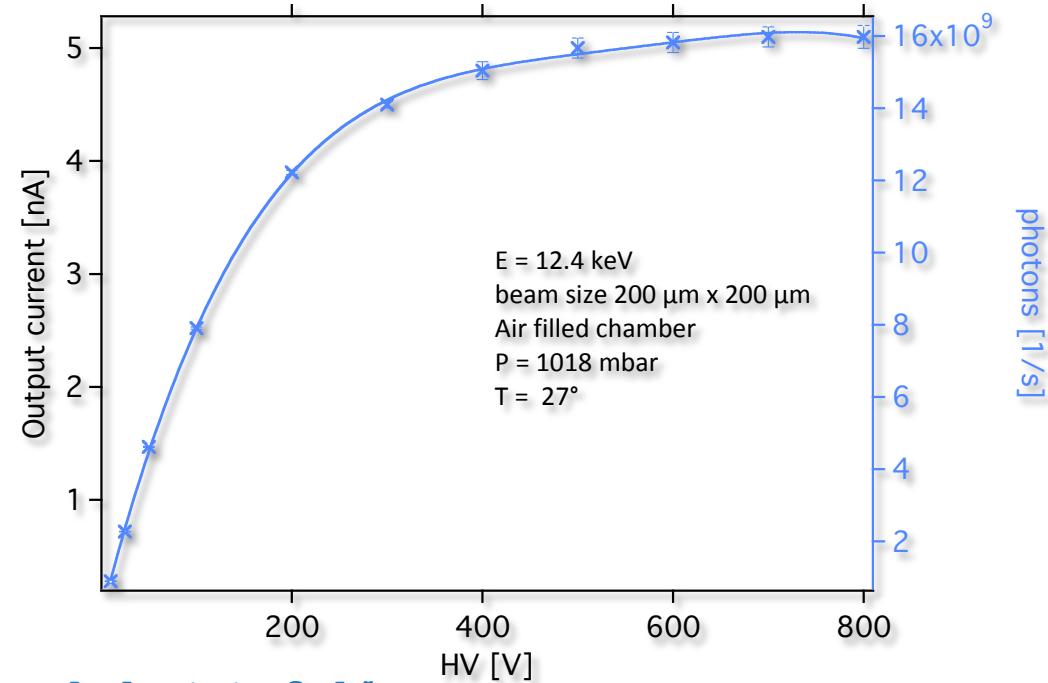
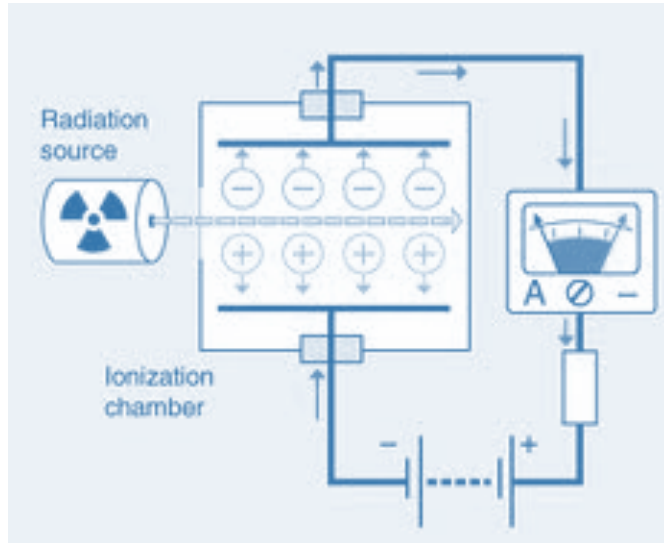

Drift of charges in the external electric field

$$\vec{v}_{drift} = \mu^{\pm} \cdot \vec{E} \cdot \frac{P_0}{P}$$

μ mobility cm<sup>2</sup> V<sup>-1</sup>s<sup>-1</sup>

E electric field

P<sub>0</sub>=normal pressure

Ions in gas : ~ 10m/s (100 m runners)

electrons in gas : ~ 10000m/s

# Gaseous Ionisation detector regions

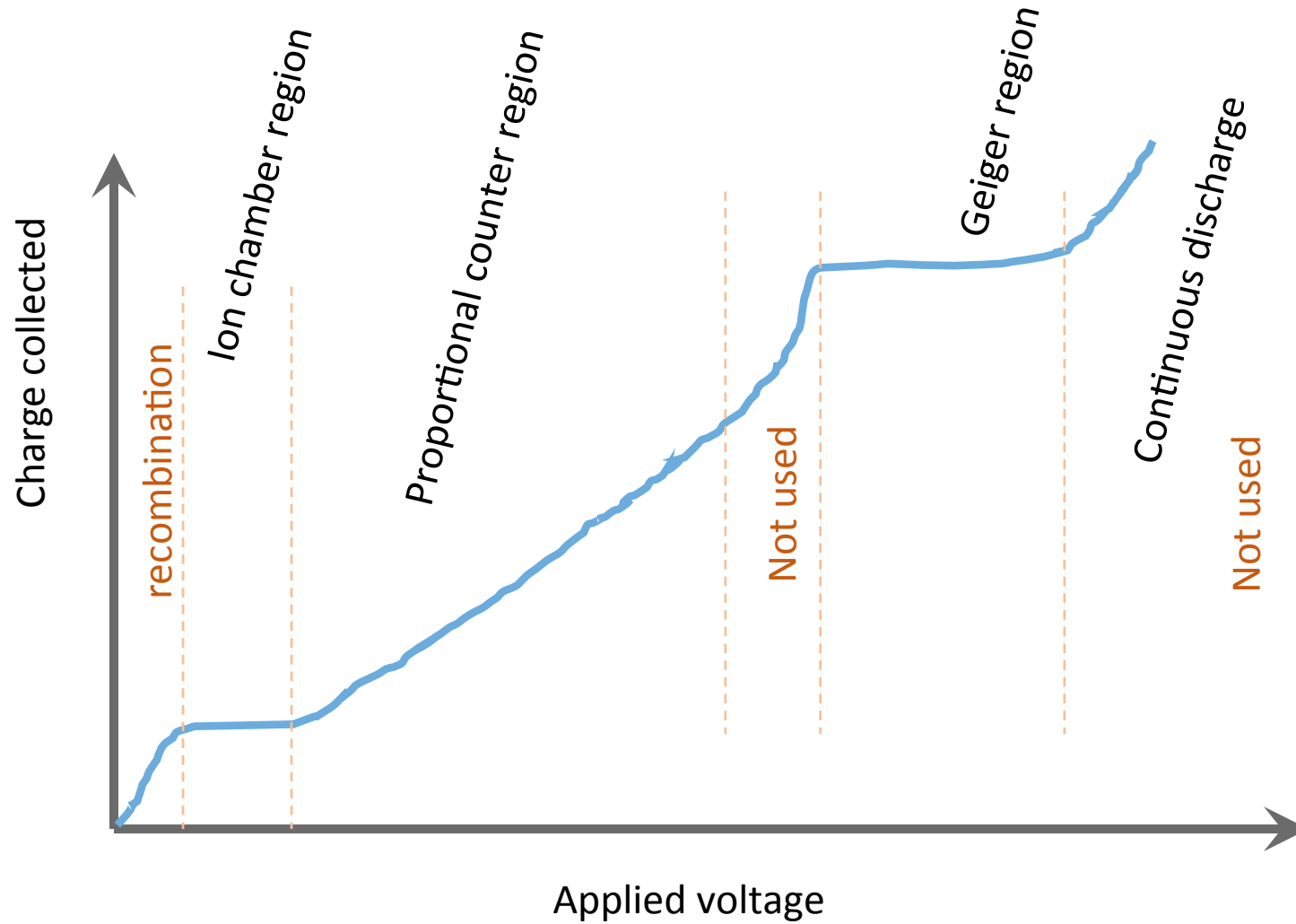

Unita' radiologiche

# Unita' radiologiche

- Fluenza: detector "photon counting"
- Intensità': detector ad integrazione di carica
- Esposizione: camere a ionizzazione
- Dose e kerma: dosimetri calibrati

**Table 6  
Radiologic Units**

Quantity	Description	Conventional Unit*
Fluence	Number of photons per unit area	1/centimeter <sup>2</sup> [1/meter <sup>2</sup> ]
Flux (fluence rate)	Fluence per unit time	1/(centimeter <sup>2</sup> · second) [1/(meter <sup>2</sup> · second)]
Intensity (energy fluence)	Number of photons times photon energy per unit area	kiloelectron volt/centimeter <sup>2</sup> [joule/meter <sup>2</sup> ]
Exposure (X)	Charge produced per unit mass of air from x and gamma rays	roentgen [coulomb/kilogram] <sup>†</sup>
Kerma (K)	Kinetic energy released in matter per unit mass	rad [joule/kilogram or gray] <sup>‡</sup>
Dose (D)	Energy absorbed per unit mass	rad [joule/kilogram or gray] <sup>‡</sup>

\*SI units are given in brackets.

<sup>†</sup> 1 roentgen =  $2.58 \times 10^{-4}$  coulomb/kilogram.

<sup>‡</sup> 100 rad = 1 gray.

# Exposure

ICRU (1980) International Commission on Radiation Units and Measurements

Exposure is defined as  $dQ/dm$ , where  $dQ$  is the sum of the electrical charges of all ions of one sign produced in air when all the electrons liberated by photons in a volume of air having mass  $dm$  are completely stopped in air.

$$X = dQ/dM$$

*The ionization arising from the absorption of bremsstrahlung or annihilation radiation emitted by the electrons is not to be included in  $dQ$ .*

*Owing to the difficulty of measurement, exposure is not normally used when the photon energy exceeds 3 MeV.*

Unita' di misura:

Sistema Internazionale  $C\ kg^{-1}$

Roentgen  $R = 2.58 \cdot 10^{-4}\ C\ kg^{-1}$

*NB: Average atomic number of air and soft tissue is about the same !*

# Misura di esposizione

...tutti gli elettroni liberati dai fotoni in una massa d'aria  $dm$  si sono completamente fermati in aria.

Equilibrio di particelle cariche

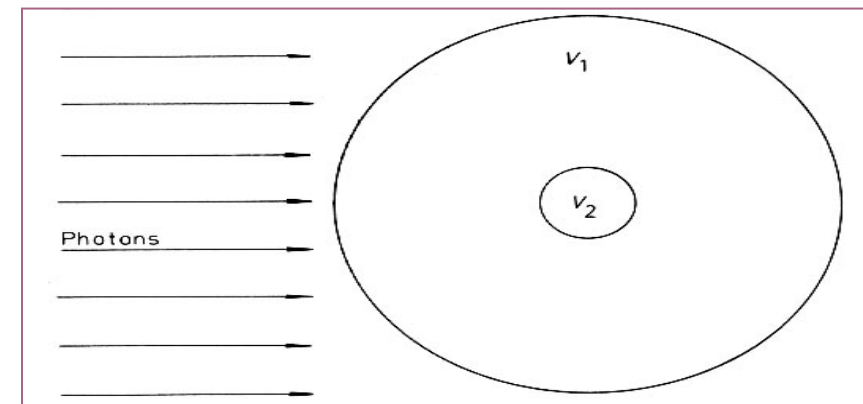
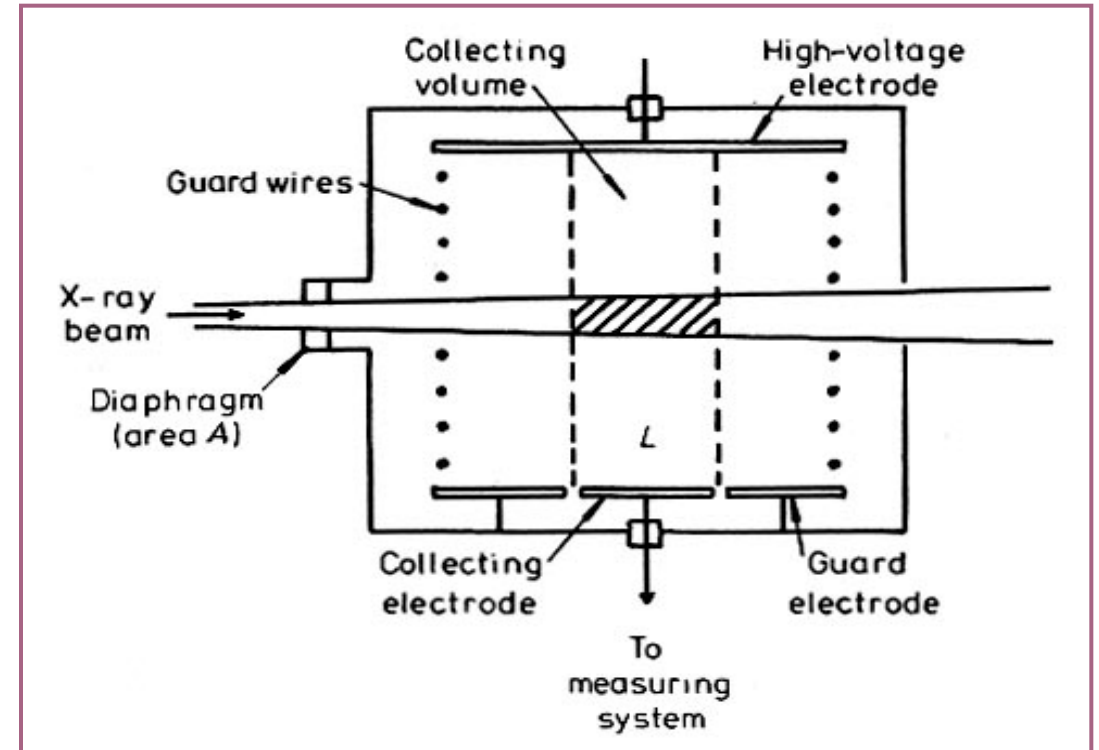
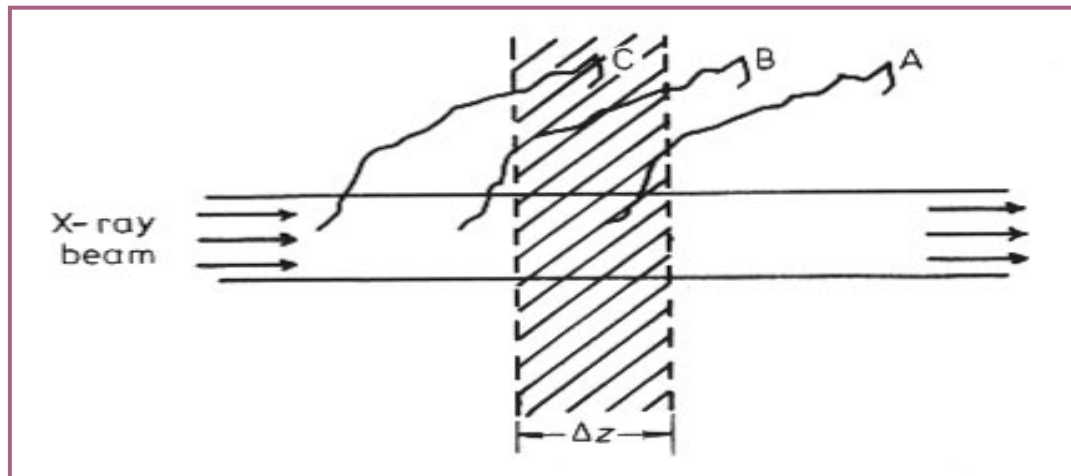

# Dose

- Dose is the energy absorbed by the unit of mass

$$D = \frac{dE}{dm}$$

- Not volume !!
- 1 Gy (gray) = 1 J/kg
- This relates to the amount of energy actually absorbed
  - Scatter radiation not negligible
- The gray unit can be used for any type of radiation, but it does not describe the biological effects of the different radiations.

## Exposure and absorbed dose in air

How do we measure them X rays? X-ray beam can be measured using the ionization it produces in air. An *ionization chamber* is an air-filled chamber surrounded by electrodes (a positive and negative electrode). X rays ionize the molecules of air present in the chamber, and the electrons follow the electric field lines and are collected on the positive electrode, while the positive ions are collected on the negative electrode. The net charge is collected on the electrodes. The unit of exposure is the roentgen (R), where:

$$1R = 2.58 \times 10^{-4} \text{ C/kg}$$

A typical ionization chamber for general diagnostic measurements has a volume of approximately 6 cm<sup>3</sup>. At standard temperature and pressure, the mass of air in 6 cm<sup>3</sup> is about 7.8 mg. A 1-R exposure will liberate a charge of  $2.0 \times 10^{-9}$  coulombs inside the chamber, corresponding to  $1.2 \times 10^{10}$  ions.

The roentgen is defined only in air, and under conditions of electron equilibrium. Electron equilibrium occurs when the number of energetic ions entering the measurement volume equal those leaving it.

Empirically it takes  $W=33.97$  eV to produce an ion pair in air, equal to 33.97 joules/C. Thus the energy absorbed in air/mass, i.e. **absorbed dose in air, by a 1-R exposure is:**

$$D_{\text{air}} = E_{\text{abs}}/m = 2.58 \times 10^{-4} \text{ C/kg} \times 33.97 \text{ J/C} = 0.00876 \text{ J/kg} = 0.00876 \text{ Gy}$$

Exposure (X) corresponds to *absorbed dose* in air:

$$D_{\text{air}} \text{ (mGy)} = 0.00876 \text{ X(mR)}$$

$$D_{\text{air}} \text{ (mGy)} = 8.76 \text{ X(R)}$$

# Effective biological effects

- The Sievert (Sv) is the unit of the equivalent dose.
- Equivalent dose relates the absorbed dose in human tissue to the effective biological damage of the radiation.
- Not all radiation has the same biological effect, even for the same amount of absorbed dose.
- To determine equivalent dose (Sv), the absorbed dose (Gy) is multiplied by a quality factor (Q) that is unique to the type of incident radiation.

# Calibrazione di IC

- L'esposizione e' la sola grandezza dosimetrica per cui esistano degli standard nazionali.
  - in Italia e' competenza dell'ENEA
    - Standard primari, secondari e oltre ...
- IC "pratiche" vanno calibrate con uno standard
  - le calibrazioni avvengono con gli standard secondari
  - La calibrazione e' funzione dell'energia
- Problemi che richiedono correzioni:
  - Attenuazione finestra dello strumento
  - La eventuale ricombinazione di elettroni
  - Vapor d'acqua
  - Ionizzazione secondaria (bremsstrahlung o altro)

# The PTW 23344 ionization chamber

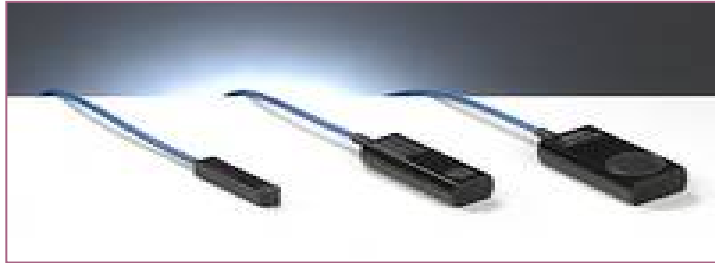

Plane parallel chambers with thin membranes for measuring therapeutic X-rays in air and solid state phantoms

- Vented sensitive volumes of 0.20 cm<sup>3</sup>
- Very thin flat entrance windows for dose measurements of low energy X-ray beams

**PTW FREIBURG** Calibration Certificate No. 010713  
 D-79115 Freiburg, Löffelackerstr. 7  
 ☎ (0761) 49055-0 FAX (0761) 49055-70

<b>Ionization chamber</b>	Type/Ser. - No. B23344-0774
<b>Manufacturer:</b>	PTW FREIBURG
<b>Conditions of climate:</b>	Temperature between: 18 and 24 degrees Celsius Air pressure between: 950 and 1050 hPa Relative humidity: approx. 40 - 60 %
<b>Arrangement of chamber / detector:</b>	Chamber membrane showed towards source.
<b>Reference point:</b>	See data sheet of chamber / detector.
<b>Radiation conditions:</b>	Exposure rate between: 0.1 and 10 R/min Exposure between: 0.2 and 150 R
<b>Leakage during measurement was:</b>	negligible

**Use of the Calibration Factor:**  
 The result of a measurement in exposure is Exposure rate is determined similarly.

$$N_S = k_Q \times k_D \times N_S \times M$$

**Calibration Factor**  **$N_S = 8,987e+09 \text{ R / C}$**   
 (at +400V, 22°C, 1013 hPa,  $\times E + y$  meaning  $\times \cdot 10^y$ )

**Radiation qualities:**

Q	Filter mm	S <sub>1</sub> mm	a cm	F cm	k <sub>Q</sub>	s
T15	0.05Al	0.06Al	30	3.0∅	1.03	+/-2.2%
T30	0.55Al	0.37Al	30	3.0∅	1.00	+/-2%
T50	1.05Al	0.93Al	30	3.0∅	1.00	+/-2%
T70	4.04Al	2.9Al	30	3.0∅	1.00	+/-2%

Q : beam quality ( the number indicating the tube voltage )  
 Filter: total filter ( inherent and additional filter )  
 s<sub>1</sub> : half value isyer at the point of measurement  
 a : focus distance between source and point of measurement (in air)  
 F : field size at point of calibration  
 N<sub>S</sub> : calibration factor for exposure  
 k<sub>Q</sub> : radiation quality correction  
 s : uncertainty of calibration factor  
 M : Display reading (in C)  
 k<sub>D</sub> : air density correction

The uncertainty stated corresponds to the double standard deviation (k=2). The standard deviation was calculated according to WECC Doc. 18 from the partial uncertainties arising from the normal used, the calibration procedure, the environmental conditions and short time effects of the object of measurement. The uncertainties stated are composed of the uncertainties of the calibration procedure and those of the specimen during calibration. A share for the long term instability of the object under calibration is not included.

The calibration is traceable to national standards of the German National Laboratory, PTB, Braunschweig. This calibration certificate may not be reproduced other than in full except with the permission of the issuing laboratory. This certificate is valid only with the ionisation chamber showing the intact sticker with the certificate number. The calibration factors of chambers having been opened for repair are not comparable to previous calibrations. Test certificates without signature are not valid.

---

Freiburg, 13. Feb. 2001

PTW - FREIBURG  
 Physikalisch-Technische  
 Werkstätten Dr. Pichler GmbH

### Use of the Calibration Factor:

The result of a measurement in exposure is  
Exposure rate is determined similarly.

$$J_s = k_Q \times k_D \times N_s \times M$$

### Calibration Factor

$$N_s = 8,987e+09 \text{ R / C}$$

(at +400V, 22°C, 1013 hPa, x E +y meaning x - 10<sup>y</sup>)

### Radiation qualities:

Q	Filter mm	S <sub>1</sub> mm	a cm	F cm	k <sub>Q</sub>	ε
T15	0.05Al	0.06Al	30	3.0∅	1,03	+/-2.2%
T30	0.55Al	0.37Al	30	3.0∅	1,00	+/-2%
T50	1.05Al	0.93Al	30	3.0∅	1,00	+/-2%
T70	4.04Al	2.9Al	30	3.0∅	1,00	+/-2%

Q : beam quality ( the number indicating the tube voltage )

Filter: total filter ( inherent and additional filter )

s<sub>1</sub> : half value layer at the point of measurement

a : focus distance between source and point of measurement  
(in air)

F : field size at point of calibration

N<sub>s</sub> : calibration factor for exposure

k<sub>Q</sub> : radiation quality correction

ε : uncertainty of calibration factor

M : Display reading (in C)

k<sub>D</sub> : air density correction

# Calibration conditions

<b>Ionization chamber</b>	<b>Type/Ser. - No. B23344-0774</b>
<b>Manufacturer:</b>	<b>PTW FREIBURG</b>
<b>Conditions of climate:</b>	Temperature between: 18 and 24 degrees Celsius Air pressure between : 950 and 1050 hPa Relative humidity: approx. 40 - 60 %
<b>Arrangement of chamber / detector:</b>	Chamber membrane showed towards source.
<b>Reference point:</b>	See data sheet of chamber / detector.
<b>Radiation conditions:</b>	Exposure rate between: 0.1 and 10 R/min Exposure between: 0.2 and 150 R
<b>Leakage during measurement was:</b>	negligible