



# Progettazione Meccanica CAD/CAE Integrata

A.A. 2025/2026

## Analisi strutturale in ambiente virtuale

### Introduzione-II parte

## Elementi monodimensionali - Elementi piani

Ph.D. Eng. Domenico Marzullo



**UNIVERSITÀ  
DEGLI STUDI  
DI TRIESTE**

**Dipartimento di Ingegneria e Architettura  
Università degli Studi di Trieste**

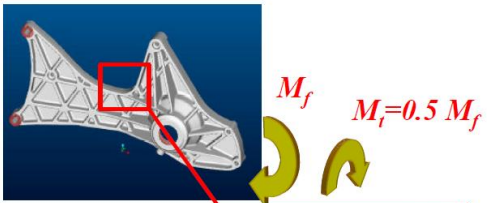
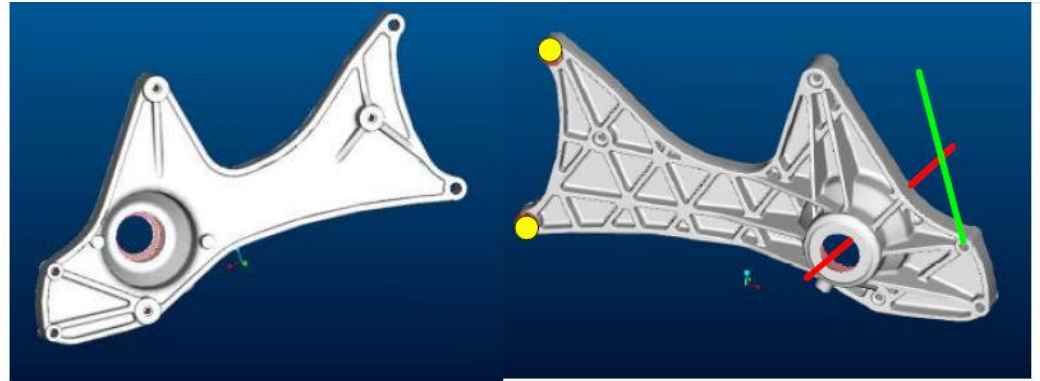
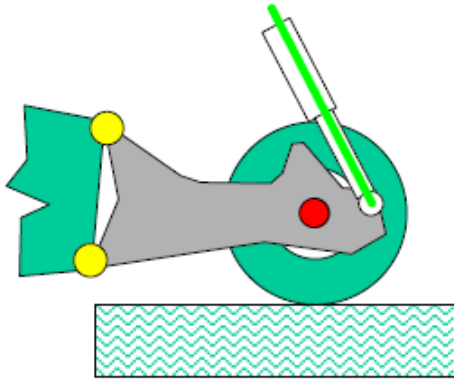

**MODALITÀ DI ROTTURA**

$R=0.1$

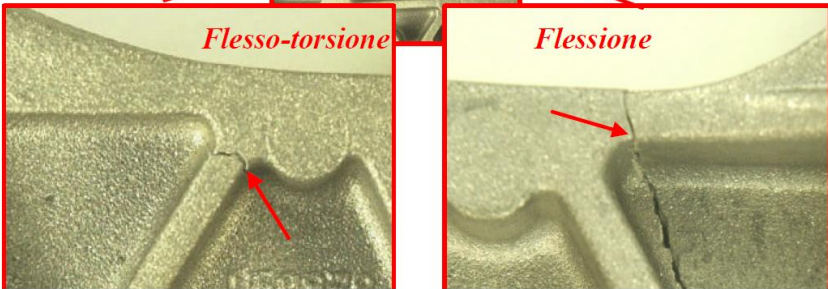
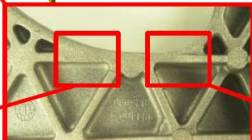

*Prevista*

*Effettiva*

*Flessione*

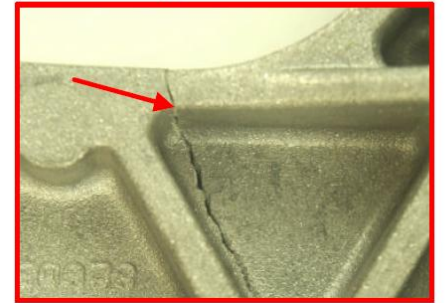
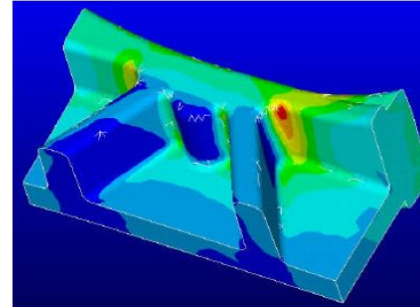

*Flessio-torsione*

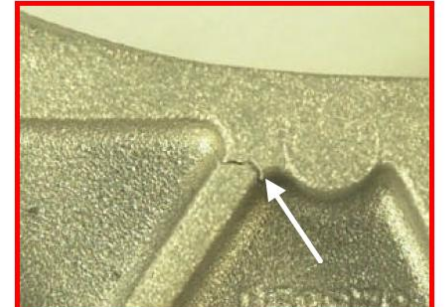
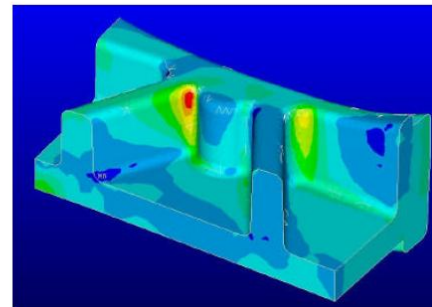

## Continuous system



## Classical Analysis

Real structures

governed by PDEs

$$\frac{\partial^2 u}{\partial^2 x} + \frac{\partial^2 u}{\partial^2 y} + \frac{\partial^2 u}{\partial^2 z} = 0$$



Discretisation



## Discrete system



## FEM

Structural Model

governed by matrix equation

$$[M]\{\ddot{u}\} + [B]\{\dot{u}\} + [K]\{u\} = P(t)$$





$[M]$  - mass  
 $[B]$  - damping  
 $[K]$  - stiffness  
 $\{\ddot{u}\}$  - acceleration vector

$\{\dot{u}\}$  - velocity vector  
 $\{u\}$  - displacement vector  
 $P(t)$  - applied load

There are many practical engineering problems for which we **cannot** obtain **exact solutions**. This inability to obtain an exact solution may be due to either the **complex** nature of the governing differential equations or the **difficulties** in dealing with the boundary and initial conditions.

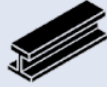
The continuum nature of the problem and of the governing equations means that the real structure cannot be analyzed as is.

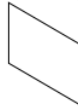
The **continuum problem** is transformed into a **discretised solution**, using the **Finite Element Method (FEM)**, a numerical procedure for solving PDEs associated with field problems.

CATEGORY	TYPE	NUMBER OF NODES	DESCRIPTION
1D	Truss 	2	A long, slender element with two nodes that can be oriented in any direction in 3D space; transmits axial force only
	Beam 	2	A long, slender element with two nodes that can be oriented in any direction in 3D space; six DoFs per node allowing three translations and three rotations
2D	Plain Strain of Stress 	3 or 4	A 2D element with only two translational DoFs per node in their plane; used in plane stress or plane strain analyses
	Membrane 	3 or 4	A 2D element that can be oriented in any direction in 3D space; transmits only in-plane loading at each node
	Shell 	From 3 to 8	A 2D element that can be oriented in any direction in 3D space; transmits all translational DoFs and rotational DoFs, except the rotation around the normal of the element
3D	Solid 	From 8 to 20	A 3D solid element having various forms; transmits only translational DoFs

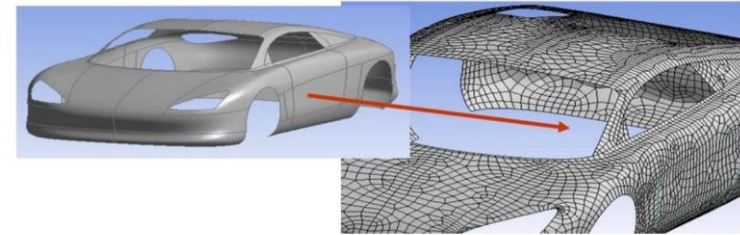
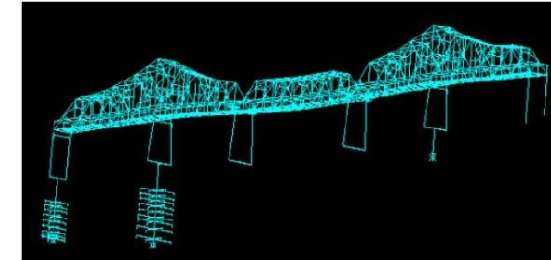

Surface Body

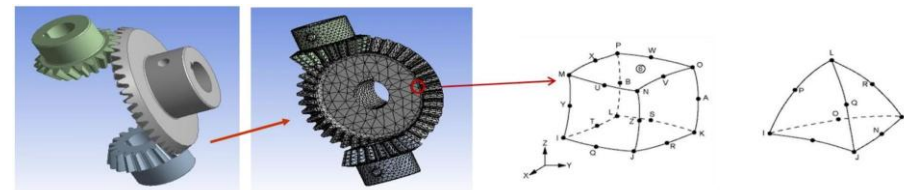







3D Solids

→ 3D Element

Hex Element

Tet Element

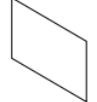
Reference: Dominique Madier. Practical Finite Element Analysis for Mechanical Engineers. FEA Academy, 2020.

CATEGORY	TYPE	NUMBER OF NODES	DESCRIPTION
1D	Truss 	2	A long, slender element with two nodes that can be oriented in any direction in 3D space; transmits axial force only
	Beam 	2	A long, slender element with two nodes that can be oriented in any direction in 3D space; six DoFs per node allowing three translations and three rotations
2D	Plain Strain of Stress 	3 or 4	A 2D element with only two translational DoFs per node in their plane; used in plane stress or plane strain analyses
	Membrane 	3 or 4	A 2D element that can be oriented in any direction in 3D space; transmits only in-plane loading at each node
	Shell 	From 3 to 8	A 2D element that can be oriented in any direction in 3D space; transmits all translational DoFs and rotational DoFs, except the rotation around the normal of the element
3D	Solid 	From 8 to 20	A 3D solid element having various forms; transmits only translational DoFs

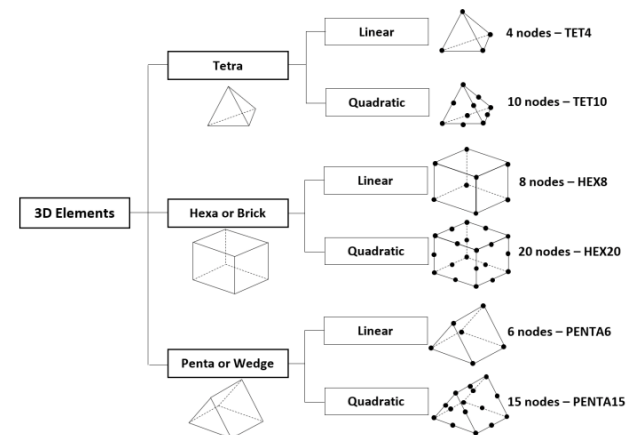
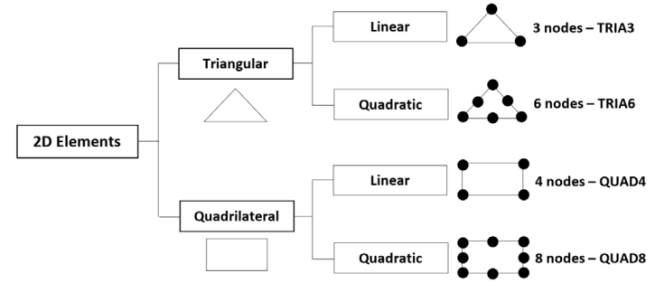
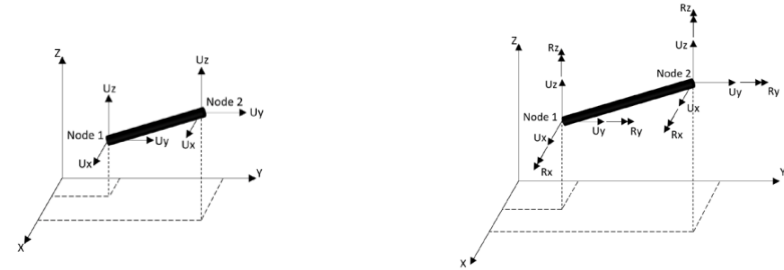

Reference: Dominique Madier. Practical Finite Element Analysis for Mechanical Engineers. FEA Academy, 2020.

Element order	3D elements			2D elements
	Solid	Shell	Beam	Plane stress Plane strain Axisymmetric
First order				
Second order				

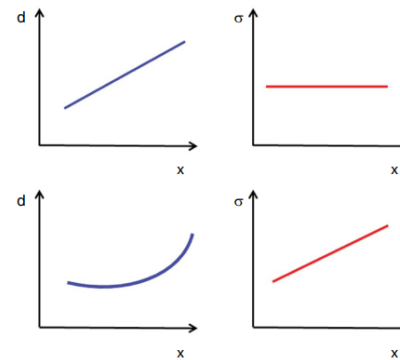

The first order element models **linear displacements** and **constant stress**

The second order element models the **second order displacements** and **linear stress**

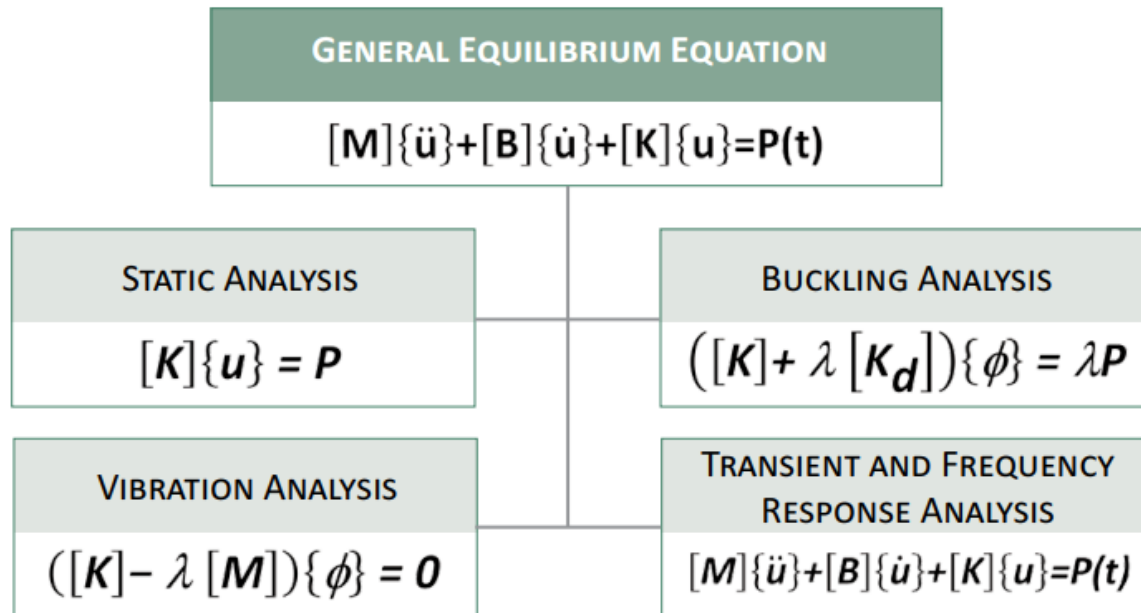

$\lambda$  is the  $i^{\text{th}}$  eigenvalue.

$\{\phi\}$  is the  $i^{\text{th}}$  eigenvector.

$[K_d]$  is the differential stiffness matrix (also called geometric stiffness).

The **displacement method** will be employed to solve structural problems.



# Displacement Method in Static Analysis



The **displacement method** (also called the **stiffness method**) assumes displacements  $\{u\}$  at the nodes as the unknowns of the problem.

Applied forces are transferred from element to element via nodes.

The compatibility of deformations (also called strain-displacement relations) requires that the displacements are continuous across the body.

In the displacement method, the key step is the formulation of the **stiffness matrix**  $[K]$

$\{F\}$  are the forces acting on the structure

$\{u\}$  are the displacements resulting from  $\{F\}$

$$\{F\} = [K]\{u\}$$

In FEM, each element is represented by its own stiffness matrix  $[K]_{\text{element}}$ .

$$\{F\} = [K]\{u\} \quad \rightarrow \quad \{u\} = [K]^{-1}\{F\}$$

$K$  : property  
 $u$  : behaviour  
 $F$  : action

	Property	Behaviour	Action
Structural	Stiffness	Displacement	Loads
Thermal	Conductivity	Temperature	Thermal source
Fluid-dynamics	Viscosity	Speed	Volume force

## Linear spring model

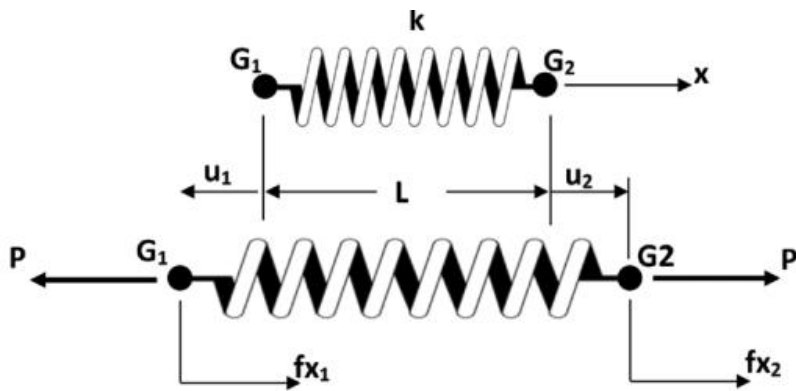

The spring deformation  $\delta = u_2 - u_1$

Hooke's law:  $P = k(u_2 - u_1)$

The equilibrium condition implies:  $f_{x_1} = -P$  and  $f_{x_2} = P$

$$\begin{aligned} f_{x_1} &= -k(u_2 - u_1) = k(u_1 - u_2) \\ f_{x_2} &= k(u_2 - u_1) = k(-u_1 + u_2) \end{aligned}$$



$$\begin{Bmatrix} f_{x_1} \\ f_{x_2} \end{Bmatrix} = \begin{bmatrix} k & -k \\ -k & k \end{bmatrix} \begin{Bmatrix} u_1 \\ u_2 \end{Bmatrix}$$

## Linear spring model

Let's apply the linear spring model result to a 2-spring system

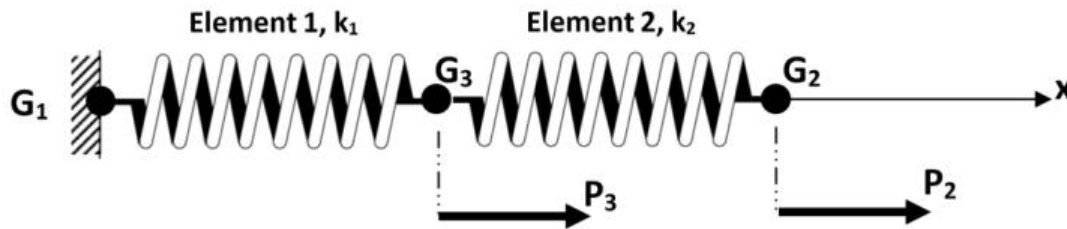

$$\text{For element 1} \quad \begin{Bmatrix} f_{x_1} \\ f_{x_3} \end{Bmatrix} = \begin{bmatrix} k_1 & -k_1 \\ -k_1 & k_1 \end{bmatrix} \begin{Bmatrix} u_1 \\ u_3 \end{Bmatrix}$$

$$\text{For element 2} \quad \begin{Bmatrix} f_{x_3} \\ f_{x_2} \end{Bmatrix} = \begin{bmatrix} k_2 & -k_2 \\ -k_2 & k_2 \end{bmatrix} \begin{Bmatrix} u_3 \\ u_2 \end{Bmatrix}$$

Compatibility of displacements:  $u_3^{element1} = u_3^{element2}$

Equilibrium at each node:  $P_1 = f_{x_1}^{element1} = k_1 u_1 - k_1 u_3$

$$P_2 = f_{x_2}^{element2} = -k_2 u_3 + k_2 u_2$$

$$P_3 = f_{x_3}^{element1} + f_{x_3}^{element2} = (-k_1 u_1 + k_1 u_3) + (k_2 u_3 - k_2 u_2)$$

$$\begin{Bmatrix} P_1 \\ P_2 \\ P_3 \end{Bmatrix} = \begin{bmatrix} k_1 & 0 & -k_1 \\ 0 & k_2 & -k_2 \\ -k_1 & -k_2 & k_1 + k_2 \end{bmatrix} \begin{Bmatrix} u_1 \\ u_2 \\ u_3 \end{Bmatrix}$$

## Linear spring model

The global stiffness matrix can also be assembled by elemental stiffness matrix

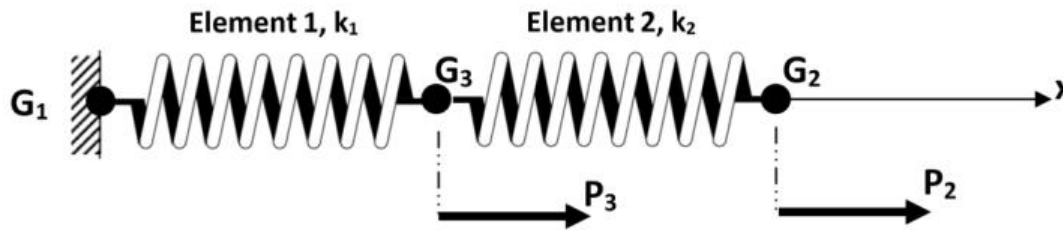

For element 1  $\begin{Bmatrix} u_1 \\ u_3 \end{Bmatrix}$

$$[K]_1 = \begin{bmatrix} k_1 & -k_1 \\ -k_1 & k_1 \end{bmatrix}$$

For element 2  $\begin{Bmatrix} u_3 \\ u_2 \end{Bmatrix}$

$$[K]_2 = \begin{bmatrix} k_2 & -k_2 \\ -k_2 & k_2 \end{bmatrix}$$

We have to assemble contributions at each node. The whole system is composed of three nodes:

$$[K]_1 = \begin{bmatrix} k_1 & 0 & -k_1 \\ 0 & 0 & 0 \\ -k_1 & 0 & k_1 \end{bmatrix}$$

$$[K] = \begin{bmatrix} k_1 & 0 & -k_1 \\ 0 & k_2 & -k_2 \\ -k_1 & -k_2 & k_1 + k_2 \end{bmatrix}$$

$$[K]_2 = \begin{bmatrix} 0 & 0 & 0 \\ 0 & k_2 & -k_2 \\ 0 & -k_2 & k_2 \end{bmatrix}$$

$$\{\sigma\} = [D]\{\varepsilon\}$$

$$\{\sigma\} = \begin{Bmatrix} \sigma_x \\ \sigma_y \\ \tau_{xy} \end{Bmatrix}$$

$$\{\varepsilon\} = \begin{Bmatrix} \varepsilon_x \\ \varepsilon_y \\ \gamma_{xy} \end{Bmatrix}$$

$$\varepsilon_x = \frac{\partial u}{\partial x}$$

$$\varepsilon_y = \frac{\partial v}{\partial y}$$

$$\gamma_{xy} = \frac{\partial u}{\partial x} + \frac{\partial v}{\partial y}$$

$$\varepsilon_x = \frac{\sigma_x - \nu\sigma_y}{E}$$

$$\varepsilon_y = \frac{\sigma_y - \nu\sigma_x}{E}$$

$$\gamma_{xy} = \frac{2(1+\nu)\tau_{xy}}{E}$$



$$[D] = \frac{E}{1-\nu^2} \begin{bmatrix} 1 & \nu & 0 \\ \nu & 1 & 0 \\ 0 & 0 & \frac{1-\nu}{2} \end{bmatrix}$$

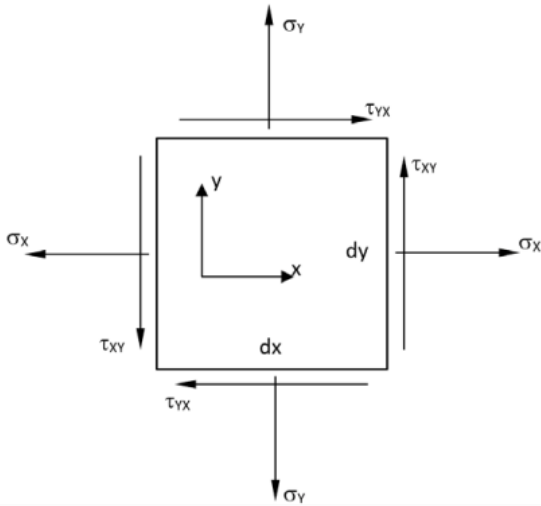

2D state of stress

For the equilibrium of the element  $\tau_{xy} = \tau_{yx}$

Nel metodo agli elementi finiti si discretizza il continuo, che ha infiniti gradi di libertà, con un insieme di elementi di dimensioni finite, tra loro interconnessi in punti predefiniti (nodi).

Elemento piano  
per problemi 2D

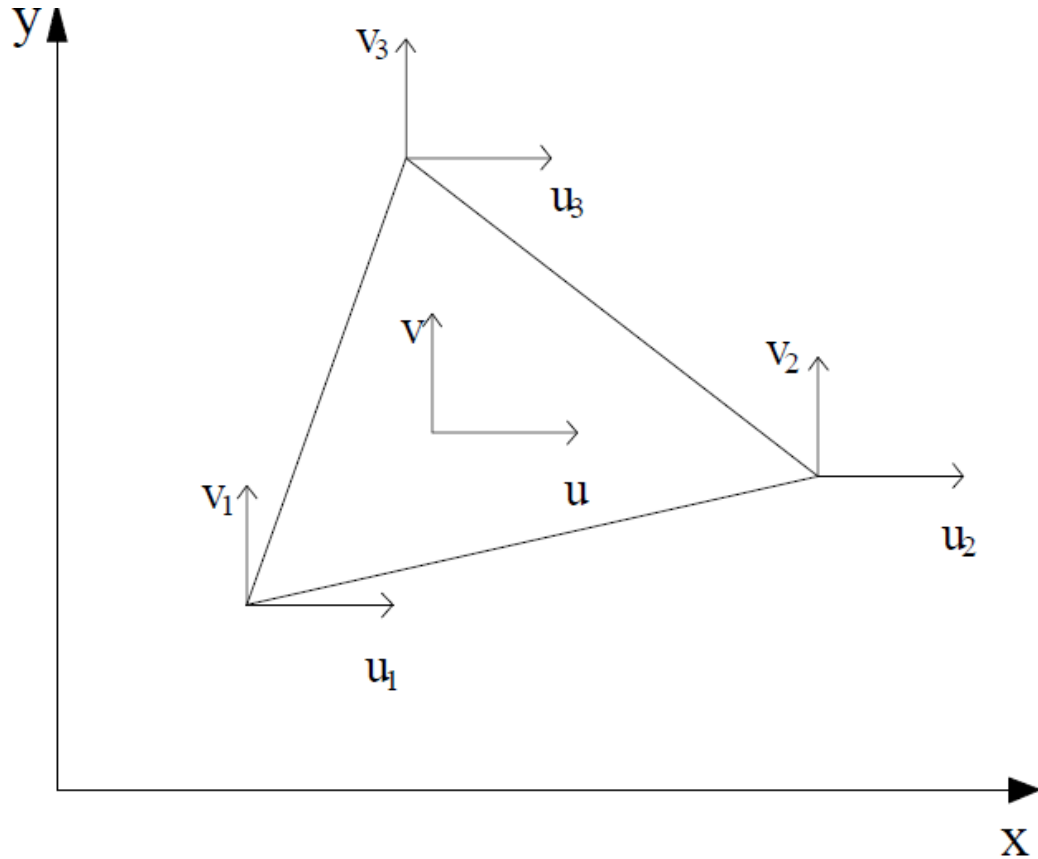

Le FUNZIONI DI FORMA legano gli spostamenti nel generico punto dell'elemento finto agli spostamenti nodali

Le funzioni di forma possono essere lineari o di grado superiore al primo

Funzioni di forma lineari:

$$u = a_1 + a_2x + a_3y$$

$$v = a_4 + a_5x + a_6y$$

$a_1, \dots, a_5, a_6$ , sono coefficienti costanti

L'utilizzo di elementi finiti con funzioni di forma lineari permette di modellare l'andamento degli spostamenti all'interno dei singoli elementi finiti attraverso funzioni lineari e richiede suddivisioni molto fitte in corrispondenza delle zone del componente in analisi in cui si prevede vi sia un elevato gradiente degli sforzi



# Funzioni di forma



L'introduzione di elementi finiti che prevedano l'utilizzo di funzioni di forma di grado superiore al primo, permette di "adeguare" il grado della funzione di forma alla particolare applicazione (si passa da polinomi interpolanti semplici a polinomi più complessi).

E' il programma di calcolo che, fissato il tipo di suddivisione in elementi finiti, utilizza funzioni di forma di grado adeguato (in maniera "gerarchica", partendo da polinomi di grado inferiore).

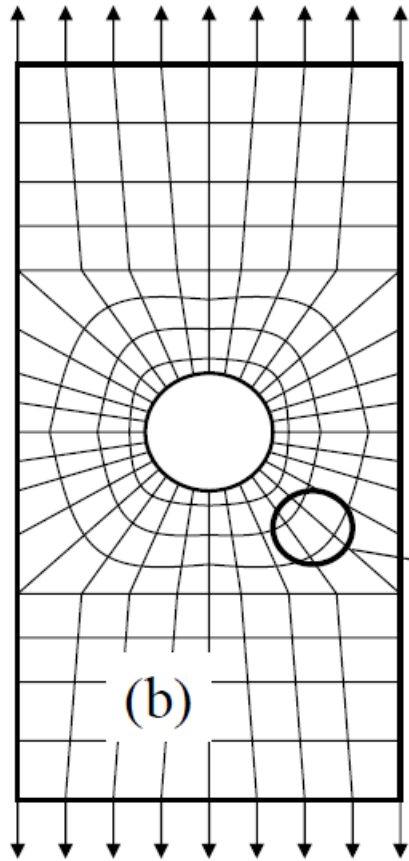

(b)

Modello (“mesh”)

$N^{\circ}$  g.d.l./nodo varia da 2 a 6 secondo:

- tipo di elemento
- natura problema

$$N^{\circ} \text{ totale g.d.l.} = N^{\circ} \text{ g.d.l./nodo} * N^{\circ} \text{ nodi}$$

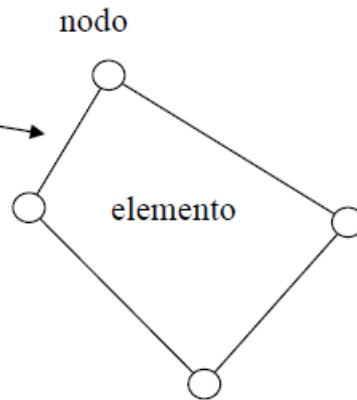

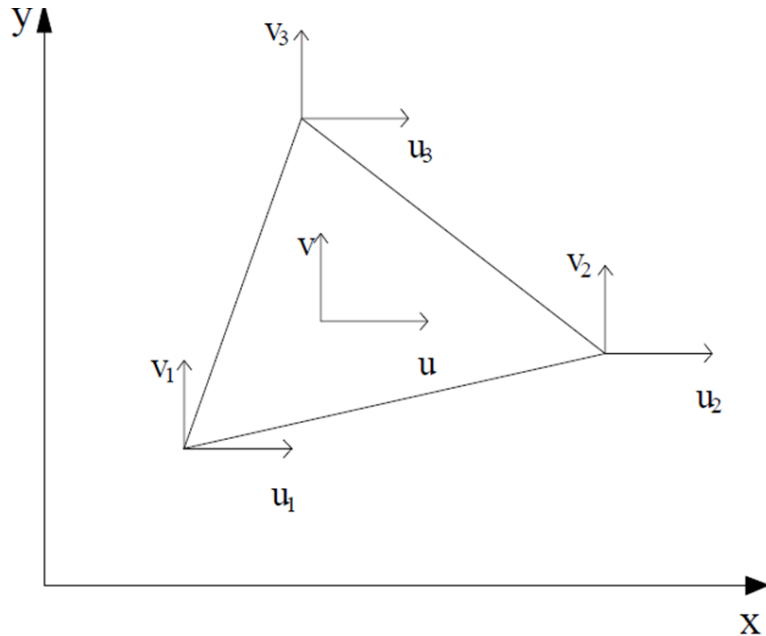

Spostamenti per i tre vertici di un elemento triangolare

$$u_1 = a_1 + a_2 x_1 + a_3 y_1$$

$$u_2 = a_1 + a_2 x_2 + a_3 y_2$$

$$u_3 = a_1 + a_2 x_3 + a_3 y_3$$

$$v_1 = a_4 + a_5 x_1 + a_6 y_1$$

$$v_2 = a_4 + a_5 x_2 + a_6 y_2$$

$$v_3 = a_4 + a_5 x_3 + a_6 y_3$$

$$\{f_n\} = [C]\{a\}$$

$$\{a\} = [C]^{-1}\{f_n\}$$

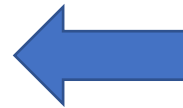

$$\begin{Bmatrix} u_1 \\ u_2 \\ u_3 \\ v_1 \\ v_2 \\ v_3 \end{Bmatrix} = \begin{bmatrix} 1 & x_1 & y_1 & 0 & 0 & 0 \\ 1 & x_2 & y_2 & 0 & 0 & 0 \\ 1 & x_3 & y_3 & 0 & 0 & 0 \\ 0 & 0 & 0 & 1 & x_1 & y_1 \\ 0 & 0 & 0 & 1 & x_2 & y_2 \\ 0 & 0 & 0 & 1 & x_3 & y_3 \end{bmatrix} \begin{Bmatrix} a_1 \\ a_2 \\ a_3 \\ a_4 \\ a_5 \\ a_6 \end{Bmatrix}$$

Lo spostamento generico dei punti interni all'elemento si scriverà in funzione degli spostamenti dei nodi, attraverso la **matrice delle funzioni di forma**

$$\{f\} = [A]\{a\}$$

$$\{f\} = [A][C]^{-1}\{f_n\} = [\Phi]\{f_n\}$$

Noti i generici spostamenti si passa alle deformazioni, definite come le derivate degli spostamenti secondo  $x$  e  $y$



$$\varepsilon_x = \frac{\partial u}{\partial x}; \quad \varepsilon_y = \frac{\partial v}{\partial y}; \quad \gamma_{xy} = \frac{\partial v}{\partial x} + \frac{\partial u}{\partial y} \quad \Rightarrow \quad \{\varepsilon\} = [B]\{f_n\}$$

Possiamo quindi ricavare lo stato di sforzo, che per stato piano di tensione e materiale isotropo sarà:

$$\begin{cases} \varepsilon_x = \frac{\sigma_x}{E} - \frac{\nu\sigma_y}{E} \\ \varepsilon_y = \frac{\sigma_y}{E} - \frac{\nu\sigma_x}{E} \\ \gamma_{xy} = \frac{2(1+\nu)\tau_{xy}}{E} \end{cases} \quad \begin{cases} \sigma_x \\ \sigma_y \\ \tau_{xy} \end{cases} = \frac{E}{1-\nu^2} \begin{bmatrix} 1 & \nu & 0 \\ \nu & 1 & 0 \\ 0 & 0 & (1-\nu)/2 \end{bmatrix} \begin{cases} \varepsilon_x \\ \varepsilon_y \\ \gamma_{xy} \end{cases}$$

$$\{\sigma\} = [D]\{\varepsilon\}$$



$$\{\sigma\} = [D][B]\{f_n\}$$

L'equazione che legghi le forze agli spostamenti nodali si ricava dal principio dei lavori virtuali

$$L_{est} = L_{int}$$

*Carichi nodali veri \*  
spost.nodali virtuali*

*Tensioni vere \*  
deformazioni virtuali*

$$F f_n = \int_V \sigma \varepsilon dV$$



$$\{F\} = [K]\{f_n\}$$

$[K]$  è una matrice di  $n_{GDL} \times n_{GDL}$  costanti definita **Matrice di rigidezza dell'elemento**

$$\{F\} = [K]\{f_n\}$$



$$\{f_n\} = [K]^{-1}\{F\}$$

$$\text{Det}[K] \neq 0$$



**Struttura non labile**

Applicare un vincolo vuol dire anche assegnare "a priori" il valore di una delle componenti di spostamento (g.d.l.) e, di conseguenza, ridurre di 1 il numero di incognite ed equazioni.

# PRINCIPALI TIPI DI ELEMENTO E LORO IMPIEGO

$$[K^E]\{u^E\} = \{F^E\}$$

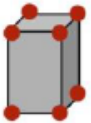

$$[K^E]\{u^E\} = \{F^E\}$$

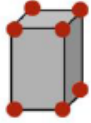

$$[K^E]\{u^E\} = \{F^E\}$$

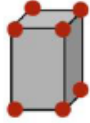

$$[K^E]\{u^E\} = \{F^E\}$$



$$[K^E]\{u^E\} = \{F^E\}$$



$$[K^E]\{u^E\} = \{F^E\}$$

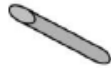

$$[K^E]\{u^E\} = \{F^E\}$$



$$[K^E]\{u^E\} = \{F^E\}$$



$$[K^E]\{u^E\} = \{F^E\}$$



$$\{u\} = [K]^{-1}\{F\}$$

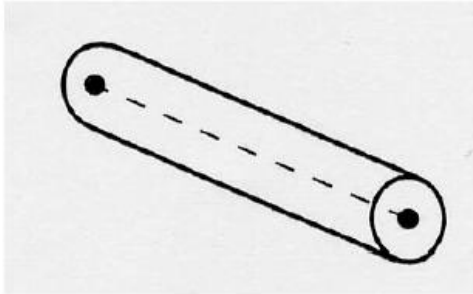

Elemento tipo trave  
a 2 nodi

TRAVE

2D

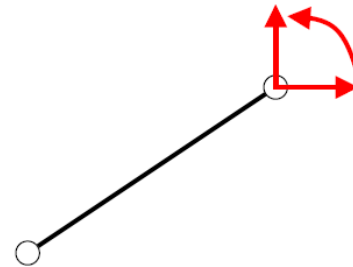

3D

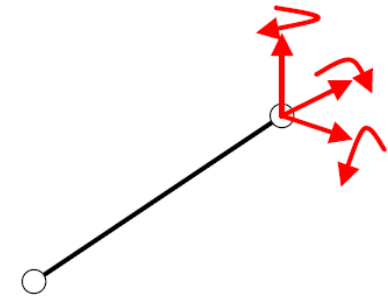

## SFORZO NORMALE

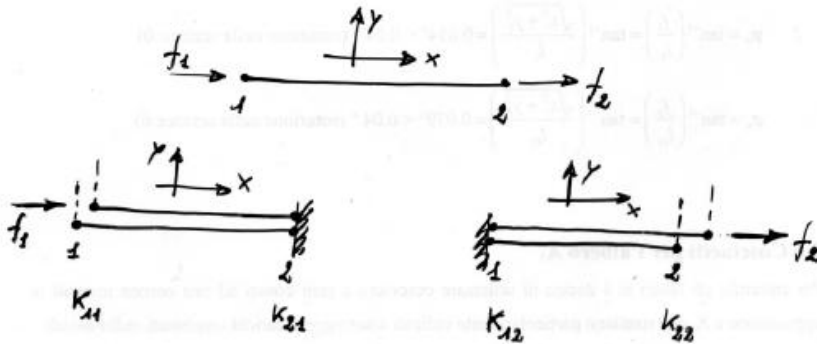

$$[k] = \begin{bmatrix} k_{11} & k_{12} \\ k_{21} & k_{22} \end{bmatrix}$$

Ordine della matrice =

Numero di punti  $\times$  gradi di libertà per punto

$$f = \frac{Fl}{EA} \quad \frac{F}{f} = k = \frac{EA}{l}$$

$$k_{11} = \frac{EA}{l} \quad k_{12} = -\frac{EA}{l} \quad k_{21} = -\frac{EA}{l} \quad k_{22} = \frac{EA}{l}$$

## SFORZO DI FLESSIONE

$$\frac{EJ_z}{l^3} \begin{bmatrix} 12 & & & \\ 6l & 4l^2 & & \\ -12 & -6l & 12 & \\ 6l & 2l^2 & -6l & 4l^2 \end{bmatrix} = [k]$$

Nel FEM vengono utilizzati elementi «beam» per la simulazione di strutture reticolari, elementi articolati (es: manipolatori robotici,...) e tutte le applicazioni riconducibili a tale tipo di elemento.

Ad una geometria di tipo «linea», viene innanzitutto associato un tipo di sezione, ne vengono definite le dimensioni e i materiali.

A questo punto la struttura viene discretizzata utilizzando elementi «beam» e vengono applicati i vincoli e i carichi.

Esempio n.1: Valutare lo stato tensionale di una trave incastrata soggetta a momento flettente per effetto della forza  $P=100\text{kN}$

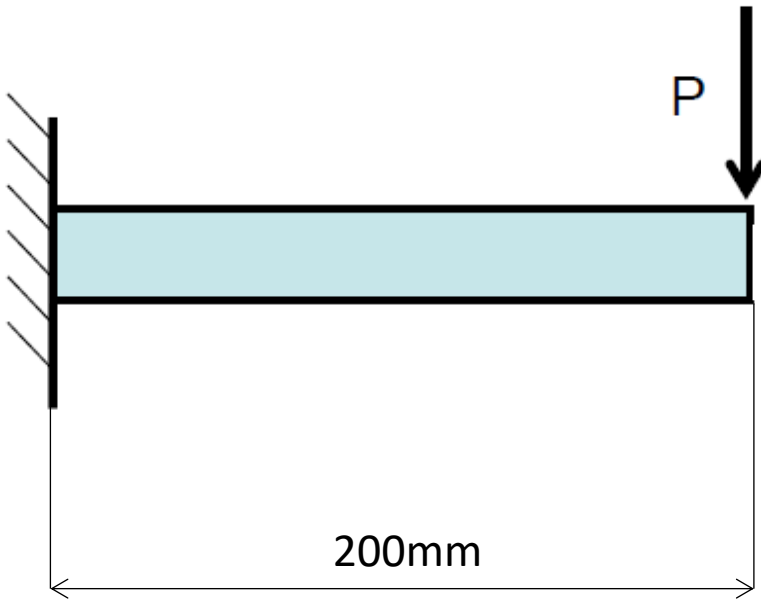

Considerare le seguenti sezioni:

1) Sezione circolare

$$D = 20\text{mm}$$

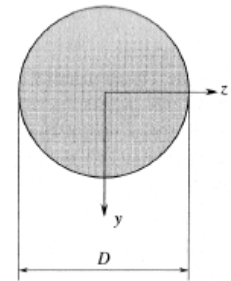

2) Sezione rettangolare

$$h = 20\text{mm}$$

$$b = 15\text{mm}$$

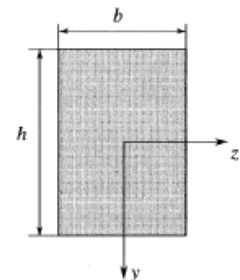

Esempio n.2: Un tubo in acciaio, incastrato ad una estremità e avente diametro esterno pari a 100 mm, deve sostenere i carichi mostrati in figura. Sapendo che le serie commerciali hanno spessori  $t$  compresi tra 6 e 24 mm, con incrementi di 3 mm, e che la tensione ammissibile per l'acciaio è di 168 MPa, determinare il tubo di minimo spessore utilizzabile

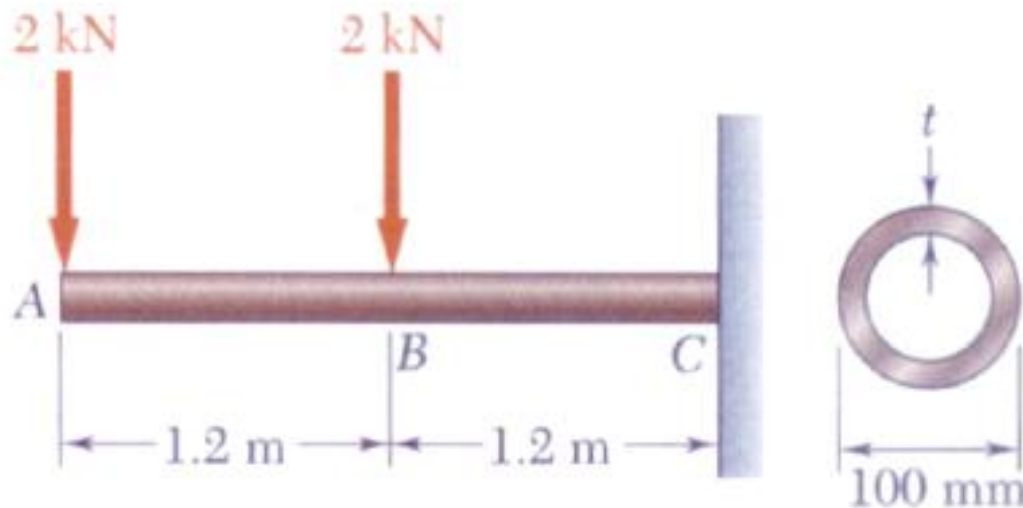

## Sforzi massimi originati dalla presenza di momento flettente

### 1) SEZIONE CIRCOLARE PIENA

$$\sigma_x = \frac{M \cdot y}{J}$$

Il momento di inerzia vale:

$$J = \frac{\pi}{64} \cdot D^4$$

Mentre  $y_{\max}$  vale  $D/2$

$$\sigma_x = \frac{M \cdot \frac{D}{2}}{\frac{\pi}{64} \cdot D^4} = \frac{64 \cdot M \cdot D}{2 \cdot \pi \cdot D^4} = \frac{32 \cdot M}{\pi \cdot D^3}$$

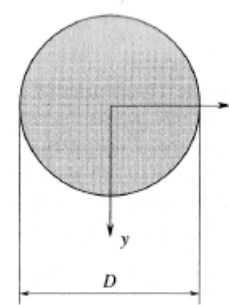

### 2) SEZIONE CIRCOLARE CAVA

Il momento di inerzia vale:  $J = \frac{\pi}{64} \cdot D^4 - \frac{\pi}{64} \cdot d^4 = \frac{\pi}{64} \cdot (D^4 - d^4)$  Mentre  $y_{\max}$  vale  $D/2$

$$\sigma_x = \frac{M \cdot \frac{D}{2}}{\frac{\pi}{64} \cdot (D^4 - d^4)} = \frac{64 \cdot M \cdot D}{2 \cdot \pi \cdot (D^4 - d^4)} = \frac{32 \cdot M \cdot D}{\pi \cdot (D^4 - d^4)}$$

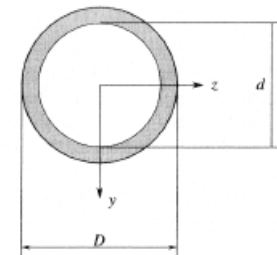

## Sforzi massimi originati dalla presenza di momento flettente

### 1) SEZIONE RETTANGOLARE PIENA

$$\sigma_x = \frac{M \cdot y}{J}$$

Il momento di inerzia vale:  $J = \frac{1}{12} \cdot b \cdot h^3$

Mentre  $y_{\max}$  vale  $h/2$

$$\sigma_x = \frac{M \cdot \frac{h}{2}}{\frac{1}{12} \cdot b \cdot h^3} = \frac{12 \cdot M \cdot h}{2 \cdot b \cdot h^3} = \frac{6 \cdot M}{b \cdot h^2}$$

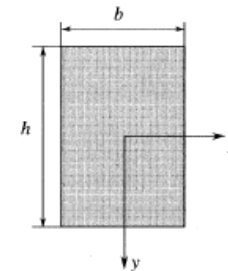

### 2) SEZIONE RETTANGOLARE CAVA (di spessore s)

Il momento di inerzia vale:  $J = J_{\text{pieno}} - J_{\text{vuoto}} = \frac{1}{12} \cdot b \cdot h^3 - \frac{1}{12} (b - 2s) \cdot (h - 2s)^3$   $y_{\max}$  vale  $h/2$

$$\sigma_{\max} = \frac{M \cdot \frac{h}{2}}{J} = \frac{6 \cdot M \cdot h}{b \cdot h^3 - (b - 2s) \cdot (h - 2s)^3}$$

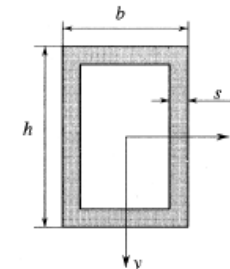

**Figure 1. PLANE42 2-D Structural Solid**

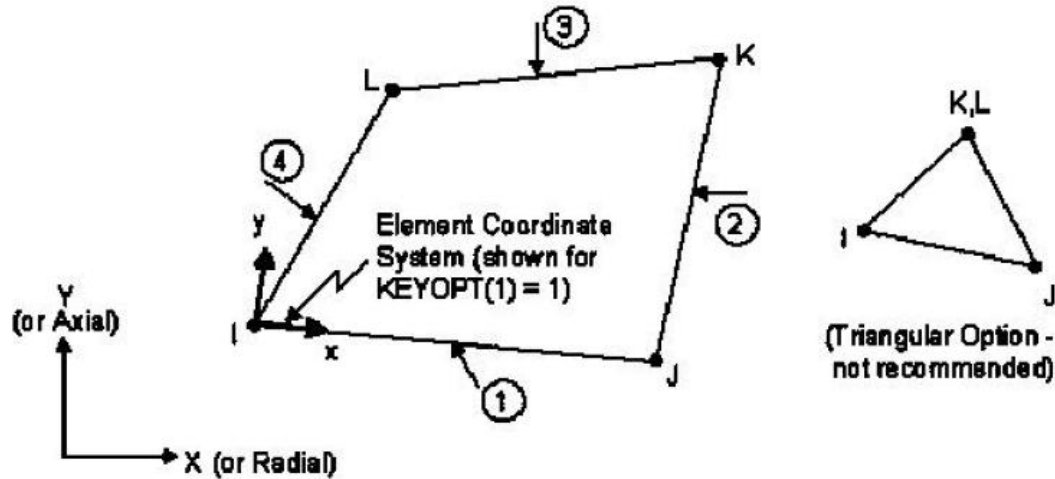

## Problemi di elasticità piana

- 4 (3) nodi
- 2 g.d.l /nodo
- tre "classi" di problemi:
- stati piani di tensione ("plane stress")
- stati piani di deformazione ("plane strain")
- stati assialsimmetrici ("axi-symmetric stress/strain")

linear rectangular element used in formulating plane-stress problems.

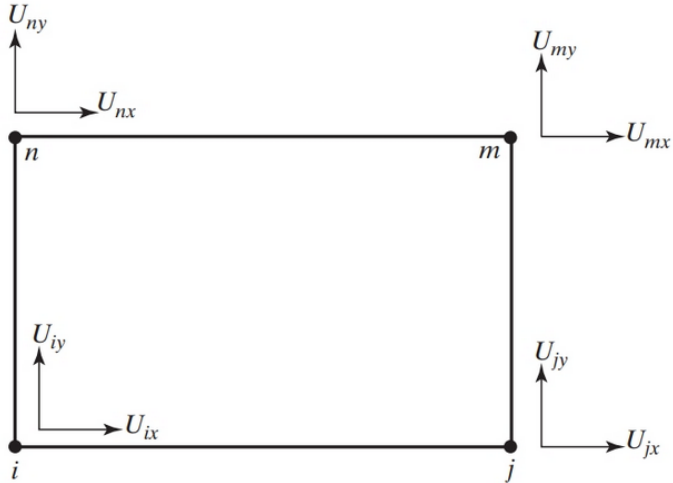

$$u^{(e)} = S_i U_{ix} + S_j U_{jx} + S_m U_{mx} + S_n U_{nx}$$

$$v^{(e)} = S_i U_{iy} + S_j U_{jy} + S_m U_{my} + S_n U_{ny}$$

Quadratic rectangular element used in formulating plane-stress problems.

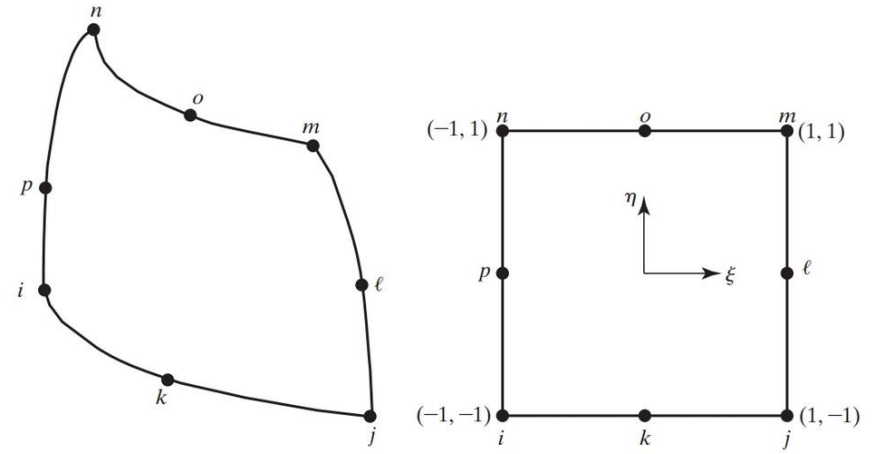

Quadratic triangular element used in formulating plane-stress problems.

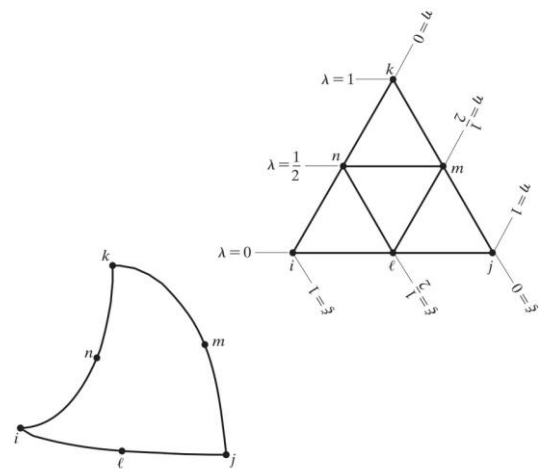

## Stati piani di tensione:

- sono caratterizzati dall'aver una delle componenti principali di tensione identicamente nulla
- si verificano tipicamente in corpi piani, di spessore piccolo rispetto alle altre dimensioni caratteristiche del problema, caricati nel loro piano medio.

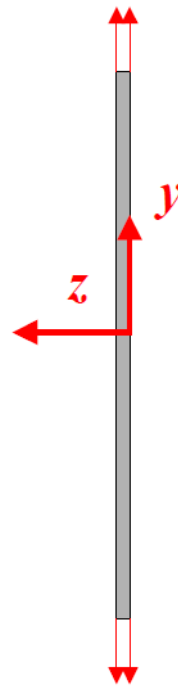
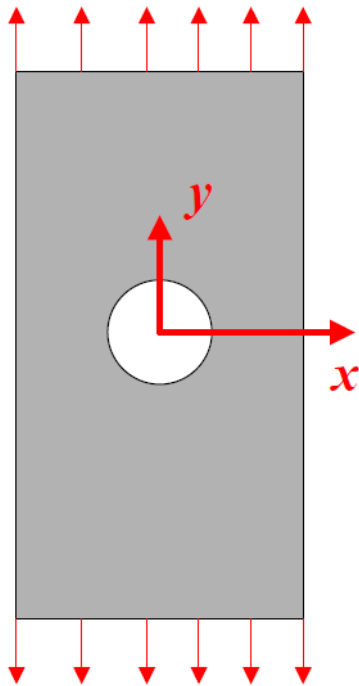

$$\sigma_z = \tau_{xz} = \tau_{yz} = 0$$

$$\sigma_x, \sigma_y, \tau_{xy} \neq 0$$

Il modello giace sul piano “x-y” e rappresenta il piano medio (a metà spessore) della struttura.

I carichi possono essere sull'intero spessore o per unità di spessore.

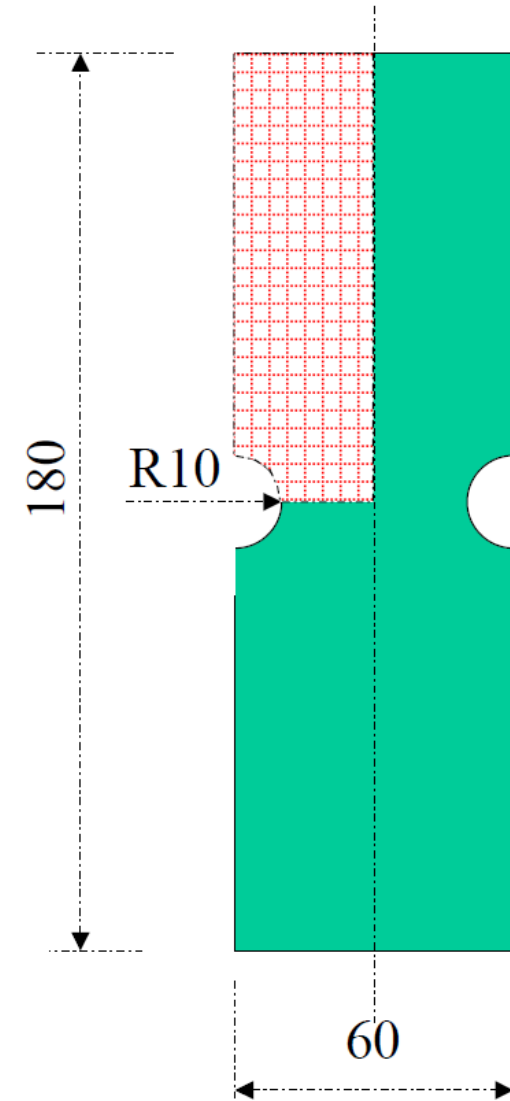
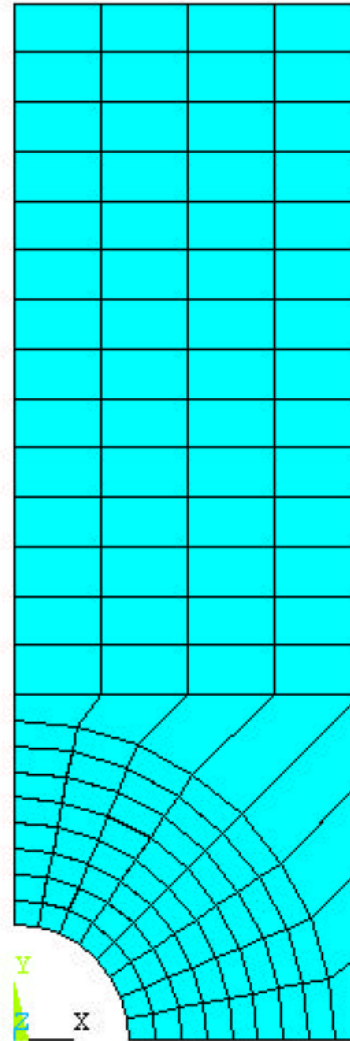

## Stati piani di deformazione:

- sono caratterizzati dall'averne una delle componenti principali di deformazione identicamente nulla
- si verificano tipicamente in corpi di spessore grande rispetto alle altre dimensioni caratteristiche del problema.

$$\varepsilon_z = \gamma_{xz} = \gamma_{yz} = 0$$

$$\varepsilon_x, \varepsilon_y, \gamma_{xy} \neq 0$$

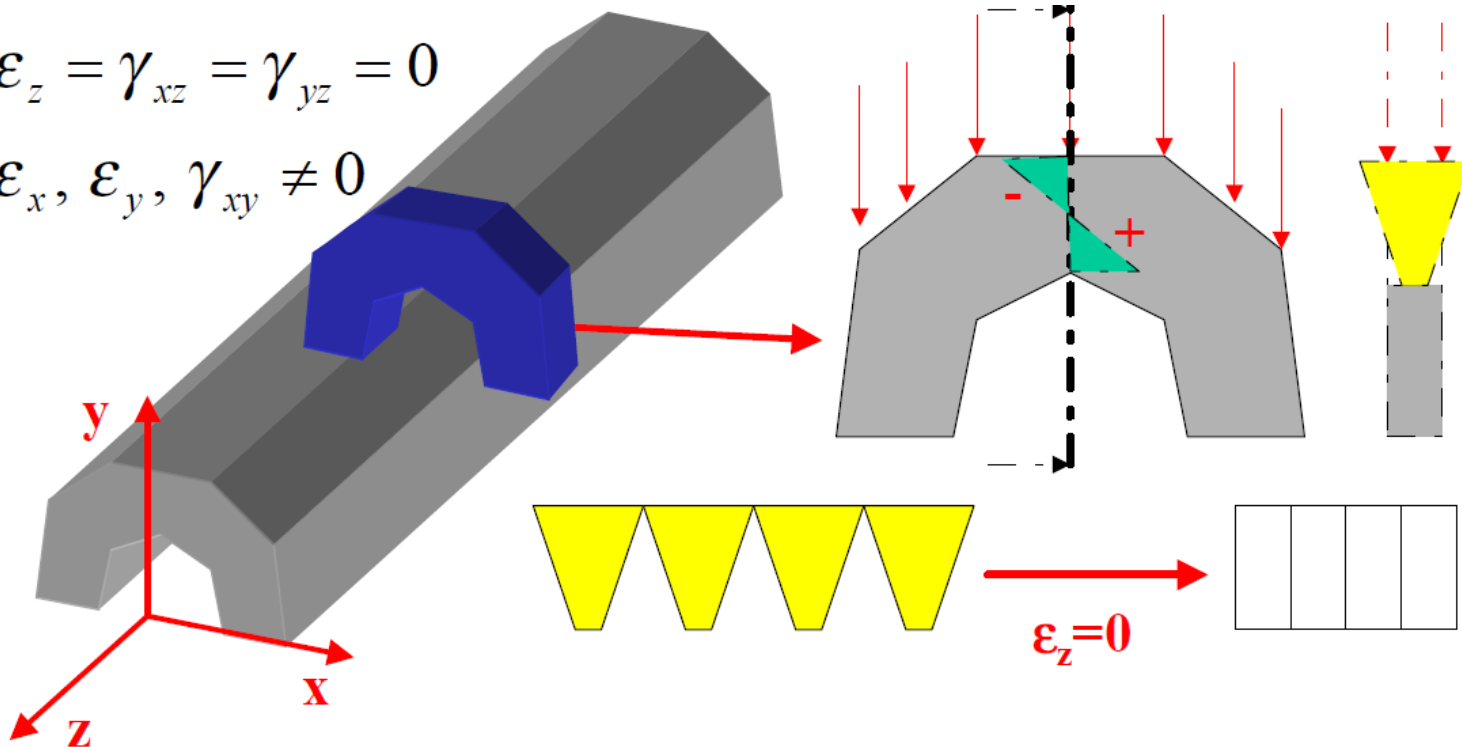

Il modello giace sul piano "x-y" e rappresenta una sezione, eseguita con un piano ortogonale all'asse z, della struttura.  
I carichi sono per unità di spessore.

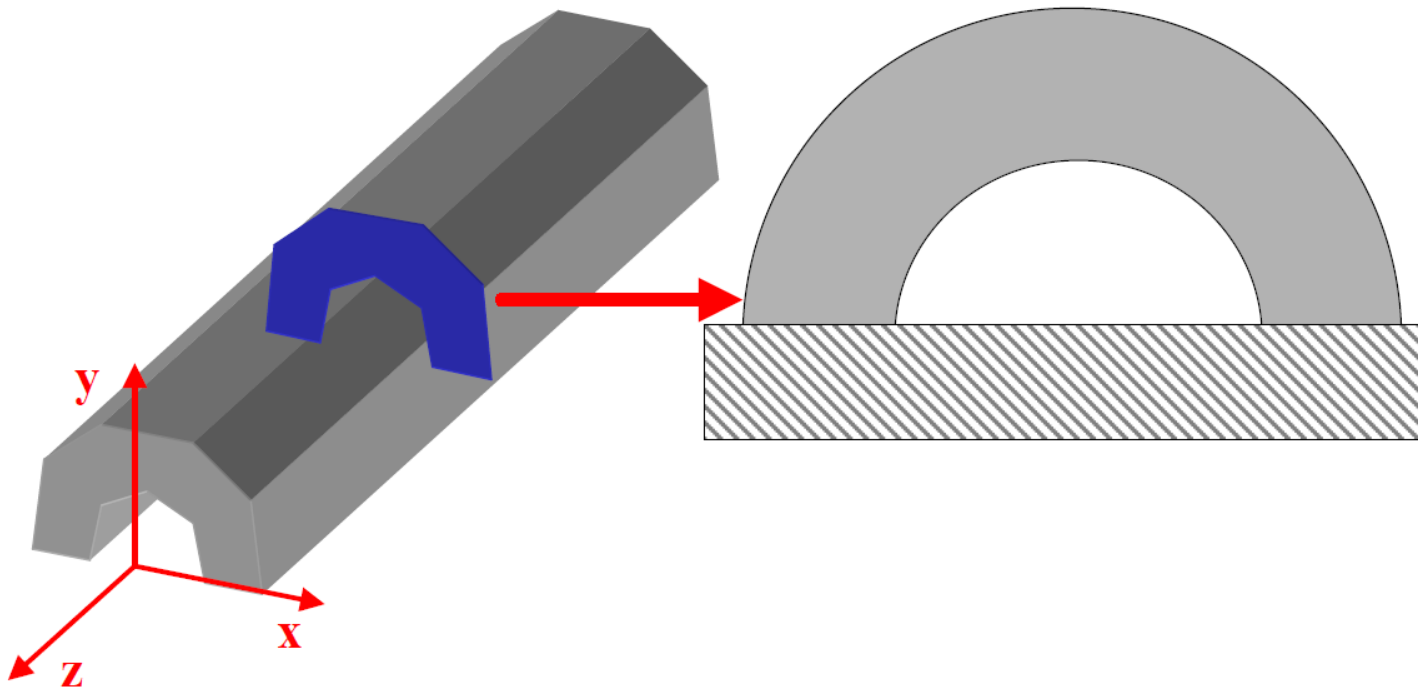

- si verificano in corpi di geometria assial-simmetrica (ottenibile per rotazione di una sezione attorno ad un asse fisso  $z$ ) carichi con carichi che presentano lo stesso tipo di simmetria.
- fissato un SR cilindrico " $\rho, \vartheta, \xi$ ", per simmetria lo stato di tensione/deformazione risulta indipendente da  $\vartheta$  e le componenti di spostamento in direzione circonferenziale ( $\vartheta$ ) risultano nulle: il problema può di conseguenza essere studiato come piano.

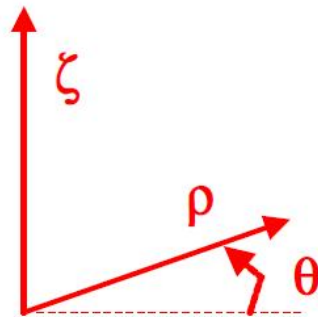

Il modello deve rappresentare una sezione del corpo fatta con un piano passante per l'asse di simmetria (in ANSYS, l'asse di simmetria e la direzione radiale devono coincidere rispettivamente con l'asse "Y" e l'asse "X" del SR cartesiano globale).

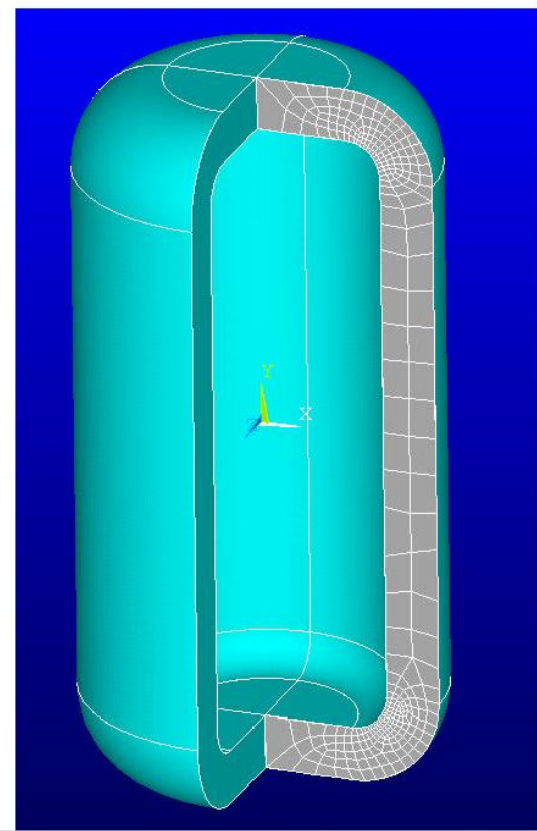
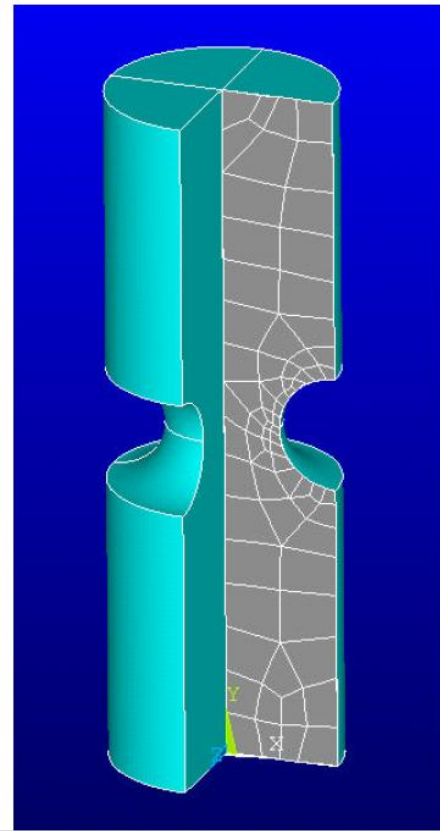

## ELEMENTO GUSCIO ASSIALSIMMETRICO

Figure 208.1: SHELL208 Geometry

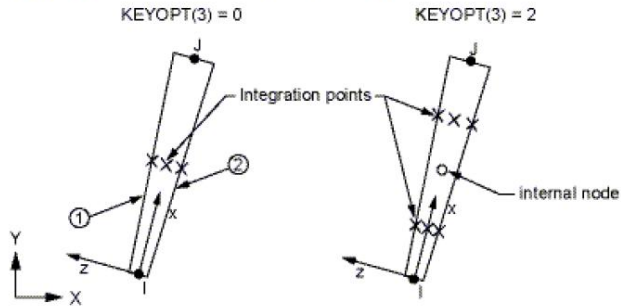

Gusci aventi geometria assialsimmetrica, soggetti a carichi assialsimmetrici (SHELL208)

- 2 nodi
- 3 g.d.l /nodo( $u_x$ ,  $u_y$  e  $\theta_z$ )

## ELEMENTO GUSCIO ASSIALSIMMETRICO

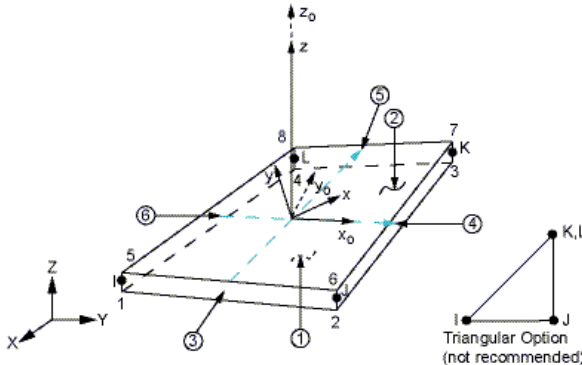

Gusci e piastre aventi geometrie qualsiasi

- 4 nodi
- 6 g.d.l /nodo

**Problemi assialsimmetrici dovrebbero essere modellati con elementi assialsimmetrici per ridurre i tempi di calcolo rispetto ai modelli 3D**

Le funzioni di forma di entrambi gli elementi si basano sull'ipotesi di Kirchoff-Love: "una linea retta normale al piano medio tracciata sul corpo prima della deformazione, risulta ancora rettilinea ed ortogonale al piano medio deformato dopo la deformazione"



Possibile ricostruire lo spostamento di ogni punto dello spessore in base a spostamenti e rotazioni del piano medio.

Limiti di validità ipotesi Kirchhoff-Love: spessore  $\ll$  altri parametri geometrici

Componenti strutturali che possano essere assimilati a "gusci" o "piastre" sottili di geometria assialsimmetrica

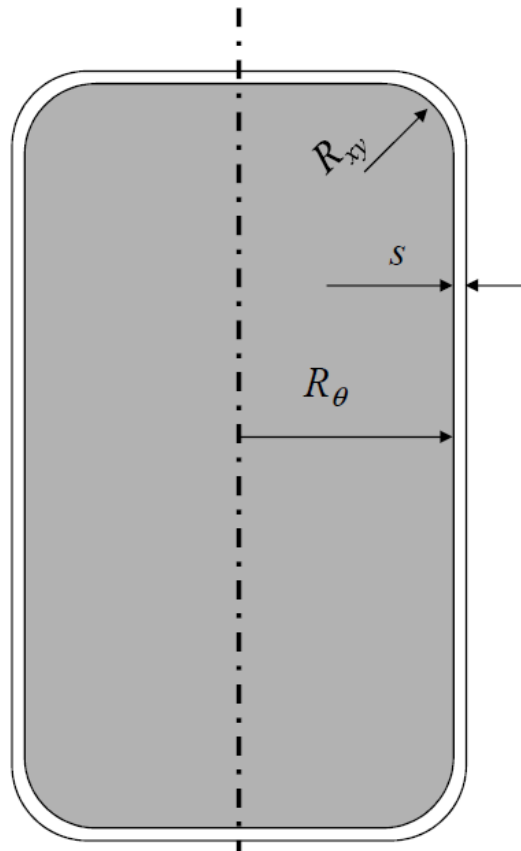

$$S \ll R_{\theta}$$

$$S \ll R_{xy}$$

- Componenti di tensione:  $\sigma_x, \sigma_y, \tau_{xy}, \tau_{xz}, \tau_{yz}$
- Andamento lineare nello spessore

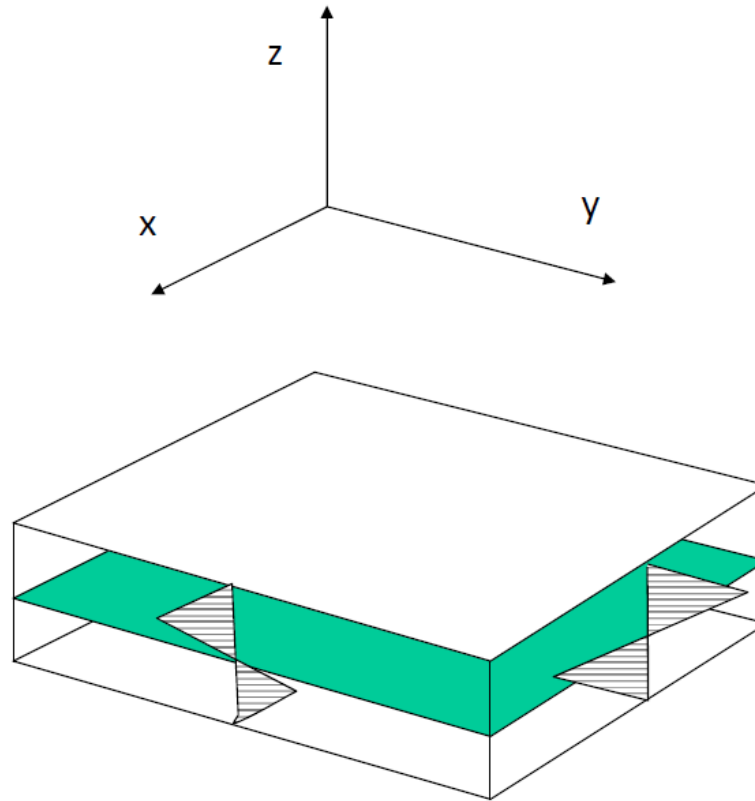

1. Componenti di tensione:  $\sigma_x, \sigma_y, \tau_{xy}, \tau_{xz}, \tau_{yz}$
2. Andamento lineare nello spessore

Viene simulato:

1. Comportamento membranale :  $u_x, u_y, u_z$
2. Comportamento membranale+flessionale:  $u_x, u_y, u_z, \theta_x, \theta_y, \theta_z$

## Teoria «membranale» dei gusci sottili

Escluse particolari zone, solitamente di limitata estensione, lo stato di tensione dei gusci sottili può essere analizzato ipotizzando che lo **stato di tensione sia costante nello spessore** (Teoria membranale dei gusci sottili)

### Ipotesi preliminari della teoria dei gusci sottili

- spostamenti sotto carico molto minori dello spessore
- punti dello spessore che, prima della deformazione, giacevano su di una retta ortogonale alla superficie media, dopo la deformazione continuano a formare una retta ortogonale alla superficie media deformata (ipotesi di Kirchhoff).
- le tensioni normali agenti ortogonalmente al piano medio della piastra siano trascurabili (stato piano di tensione)

In base alle ipotesi generali fatte, per i gusci sottili assialsimmetrici possono essere introdotte le seguenti ulteriori semplificazioni:

- la componente di spostamento in direzione circonferenziale è nulla per simmetria
- le componenti di spostamento, tensione e deformazione sono costanti in direzione circonferenziale e cambiano solo nella direzione meridiana

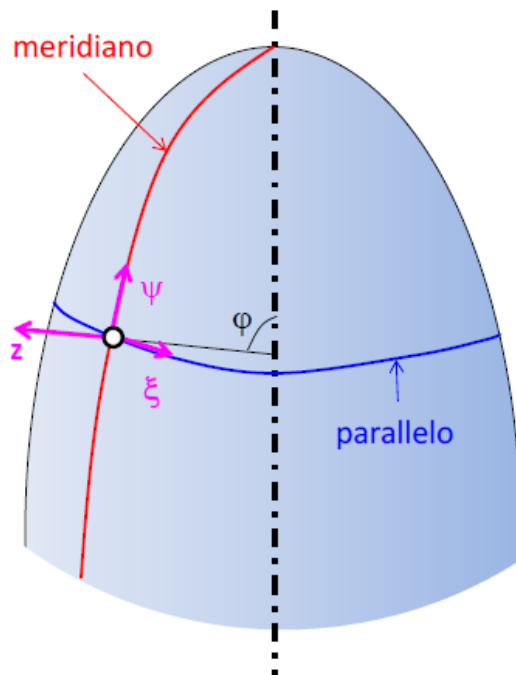

Componenti di tensione agenti

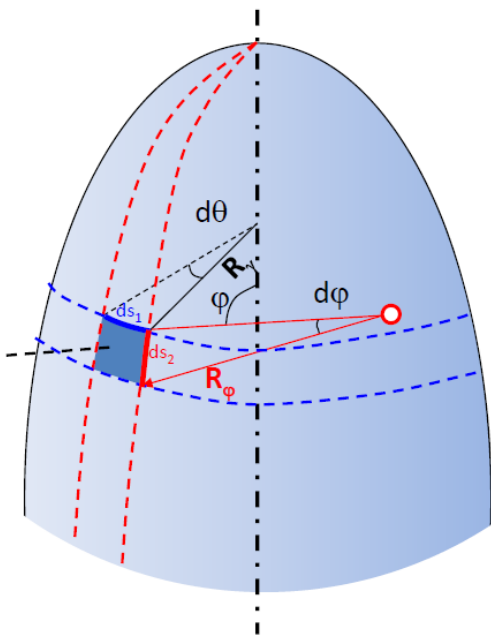
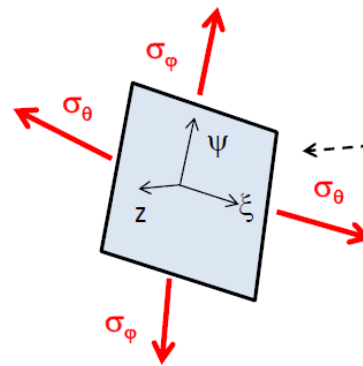



- **guscio cilindrico soggetto a pressione interna e aperto alle estremità**

$$\sigma_{\varphi} = 0 \quad \sigma_{\theta} = \frac{p \cdot R}{h} \quad \text{Formula di Boyle e Mariotte}$$

- **guscio cilindrico in pressione chiuso alle estremità (per il quale risulta invece dall'equilibrio assiale)**

$$\sigma_{\varphi} = \frac{p \cdot R}{2h} \quad \sigma_{\theta} = \frac{p \cdot R}{h} \quad \Delta R = \varepsilon_{\theta} R = \frac{\sigma_{\theta} - \nu \sigma_{\varphi}}{E} R = \frac{p \cdot R^2 (2 - \nu)}{2hE}$$

- **guscio sferico in pressione**

$$\sigma_{\theta} = \sigma_{\varphi} = \frac{p \cdot R}{2h} \quad \Delta R = \varepsilon_{\theta} R = \frac{\sigma_{\theta} - \nu \sigma_{\varphi}}{E} R = \frac{p \cdot R^2 (1 - \nu)}{2hE}$$

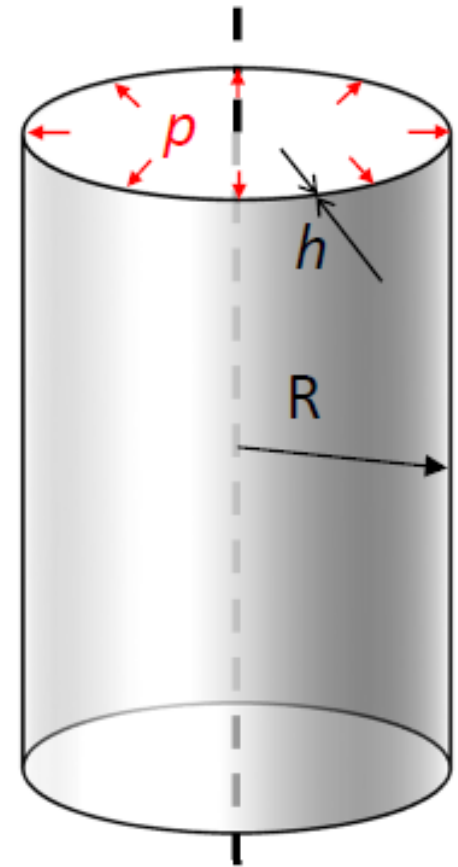

Caso più comune  $p_e = 0$  -> Le tensioni nel punto più sollecitato, cioè a  $r = r_i$  valgono

$$\sigma_t = p \frac{r_i^2 + r_e^2}{r_e^2 - r_i^2}$$

$$\sigma_r = -p$$

$$\sigma_z = \begin{cases} 0 & \text{per fondi con tiranti} \\ p \frac{r_i^2}{r_e^2 - r_i^2} & \text{per fondi di pezzo} \end{cases}$$

